

	<b>www.basler.com</b> <b>+1 618.654.2341 (USA)</b> <b>info@basler.com</b>	Model	<b>SSR Retrofit</b>
		Product	<b>Voltage Regulator</b>

## Introduction

The SSR Retrofit is an economical, direct replacement, for an existing Basler Electric SSR voltage regulator. The SSR Retrofit contains either an AVC63-12 or AVC125-10 voltage regulator and, in some cases, an AVC sensing module, both housed in a metal case. An internal sensing module is provided for 480/600 Vac nominal voltages. Impedance matching for reactive differential compensation is handled internally without the need for external resistors.

This product regulates the level of excitation supplied to the field of a conventional brushless synchronous generator. Regulation is achieved by sensing the generator output voltage, converting it to a dc signal, and comparing the signal to a reference voltage. An error signal is developed and used to control the dc field power in order to maintain a constant generator output.

An accessory input provides compatibility with devices such as var/power factor controllers or excitation limiters. The external device connected to the accessory input provides a signal to correct for vars/power factor and change the excitation level.

## SSR Retrofit Model Numbers

Table 1 lists the available SSR Retrofit model numbers.

**Table 1. SSR Retrofit Model Numbers**

SSR Retrofit Model Number	Replaces SR Model	Nominal Sensing Voltage (Vac)	Sensing Voltage Range (Vac)	Nominal Sensing Frequency (Hz)	Power Input Range (Vac)	Power Input Frequency Range (Hz)	Output Voltage (Vdc)	Output Current (Adc)
9507900200	SSR63-12	120	90–139	50/60	90–153	50–400	63	12
9507900201	SSR63-12	240	180–264	50/60	90–153	50–400	63	12
9507900202	SSR63-12	480 600	432–528 540–660	50/60	90–153	50–400	63	12
9507900203	SSR125-12 *	120	90–139	50/60	180–264	50–400	125	10
9507900204	SSR125-12 *	240	180–264	50/60	180–264	50–400	125	10
9507900205	SSR125-12 *	480 600	432–528 540–660	50/60	180–264	50–400	125	10

\* Replaces SSR-125-12 in applications requiring less than 10 A continuous output current.

## Specifications

### Power Input

9507900200 through 9507900202 ..... 90 to 153 Vac, 50 to 400 Hz, 1,092 VA

9507900203 through 9507900205 ..... 180 to 264 Vac, 50 to 400 Hz, 1,750 VA

### Sensing Input

Configuration ..... 1-phase or 3-phase

Burden ..... <1 VA per phase

Nominal Frequency..... 50 or 60 Hz

### Voltage Range

120 Vac Nominal ..... 90 to 139 Vac

240 Vac Nominal ..... 180 to 264 Vac

480/600 Vac Nominal ..... 432 to 528/540 to 660 Vac

### Current Input

5 Aac input, 10 VA maximum burden, adjustable from 0 to 10% of rated input current at 0.8 power factor. Line Drop Compensation compensates only for voltage drop due to line reactance and reactive components of the load current.

Publication	Revision	<h1>Instructions</h1>	Date	Copyright
<b>9507900991</b>	<b>D</b>		<b>May 2025</b>	<b>2025</b>

For terms of service relating to this product and software, see the *Commercial Terms of Products and Services* document available at [www.basler.com/terms](http://www.basler.com/terms).

### Accessory Input

Voltage Range .....  $\pm 3$  Vdc

### Power Output

#### Maximum Continuous Output

9507900200 through 9507900202 ..... 12 Adc at 63 Vdc  
9507900203 through 9507900205 ..... 10 Adc at 125 Vdc

#### 10 Second Forcing Output

9507900200 through 9507900202 ..... 24 Adc at 125 Vdc  
9507900203 through 9507900205 ..... 20 Adc at 250 Vdc

#### Minimum Field Resistance

9507900200 through 9507900202 ..... 5.25  $\Omega$   
9507900203 through 9507900205 ..... 12.5  $\Omega$

### Regulation Accuracy

$\pm 0.5\%$  of voltage setpoint, average response

### Voltage Drift

$\pm 0.5\%$  variation for a 104°F (40°C) change

### Response Time

<4 ms

### Frequency Compensation

One or two jumper-selectable V/Hz curves with knee frequency adjustable from 45 to 65 Hz. See Figure 1.

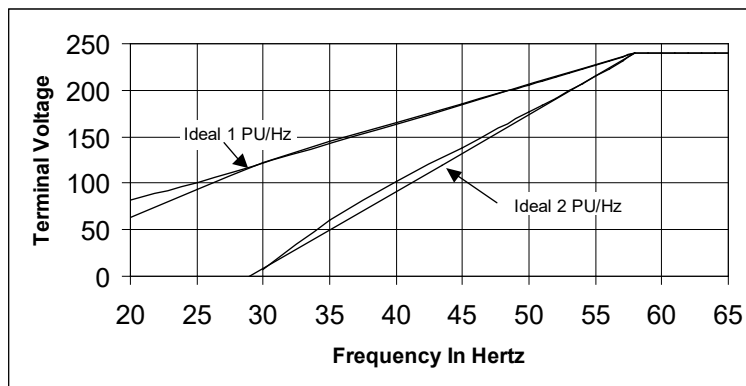

Figure 1. 60 Hz Sensing Model

### Voltage Buildup

Automatic voltage buildup occurs from residual generator voltage as low as 6 Vac (SSR Retrofit models 9507900200 through 9507900202) or 12 Vac (SSR Retrofit models 9507900203 through 9507900205).

### Overexcitation Shutdown

Overexcitation shutdown protection reduces the output voltage to zero in the times shown below for the listed voltages. Other voltages and times are based on the inverse time characteristic curves of Figures 2 and 3.

#### 9507900200 through 9507900202

125 Vdc,  $\pm 10\%$  in approximately 10 s  
210 Vdc,  $\pm 10\%$  in approximately 1 s or less

#### 9507900203 through 9507900205

250 Vdc,  $\pm 10\%$  in approximately 10 s  
360 Vdc,  $\pm 10\%$  in approximately 4 s or less

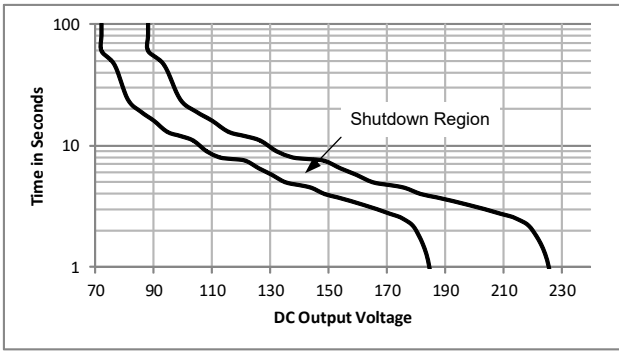

**Figure 2. Overexcitation Shutdown Characteristics, Models 9507900200 through 9507900202**

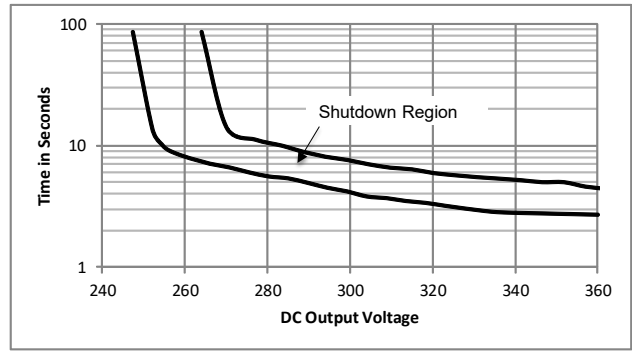

**Figure 3. Overexcitation Shutdown Characteristics, Models 9507900203 through 9507900205**

**Type Tests**

Shock

Withstands 15 G in each of 3 mutually perpendicular planes.

Vibration

Withstands the following:

- 5 to 26 Hz at 1.2 G
- 27 to 52 Hz at 0.036-inch (0.914-millimeter) double amplitude
- 53 to 1,000 Hz at 5 G for 3 hours per plane

**Physical**

Temperature

Operating ..... –40 to 158°F (–40 to 70°C)

Storage ..... –40 to 158°F (–40 to 70°C)

Max. Humidity ..... 95%, non-condensing

Weight

With Internal Sensing Module..... 9.0 lb (4.08 kg)

No Internal Sensing Module ..... 8.6 lb (3.90 kg)

## China RoHS

The following table serves as the declaration of hazardous substances for China in accordance with PRC standard SJ/T 11364-2014. The EFUP (Environment Friendly Use Period) for this product is 40 years.

PRODUCT: SSR Retrofit										
零件名称 Part Name	有害物质 Hazardous Substances									
	铅 Lead (Pb)	汞 Mercury (Hg)	镉 Cadmium (Cd)	六价铬 Hexavalent Chromium (Cr <sup>6+</sup> )	多溴联苯 Polybrominated Biphenyls (PBB)	多溴二苯醚 Polybrominated Diphenyl Ethers (PBDE)	邻苯二甲 酸二丁酯 Dibutyl Phthalate (DBP)	邻苯二甲 酸丁苄酯 Benzyl butyl phthalate (BBP)	邻苯二甲 酸二酯 Bis(2- ethylhexyl) phthalate (BEHP)	邻苯二甲 酸二异丁 酯 Diisobutyl phthalate (DIBP)
金属零件 Metal parts	O	O	O	O	O	O	O	O	O	O
聚合物 Polymers	O	O	O	O	O	O	O	O	O	O
电子产品 Electronics	X	O	O	O	O	O	O	O	O	O
电缆和互连配 件 Cables & interconnect accessories	O	O	O	O	O	O	O	O	O	O
绝缘材料 Insulation material	O	O	O	O	O	O	O	O	O	O

本表格依据 SJ/T11364 的规定编制。

O: 表示该有害物质在该部件所有均质材料中的含量均在 GB/T 26572 规定的限量要求以下。

X: 表示该有害物质至少在该部件的某一均质材料中的含量超出 GB/T 26572 规定的限量要求。

This form was prepared according to the provisions of standard SJ/T11364.

O: Indicates that the hazardous substance content in all homogenous materials of this part is below the limit specified in standard GB/T 26252.

X: Indicates that the hazardous substance content in at least one of the homogenous materials of this part exceeds the limit specified in standard GB/T 26572.

## Mounting

The SSR Retrofit is enclosed in a metal case and may be mounted in any convenient position. The SSR Retrofit may be mounted directly on a synchronous generator using UNC 1/4-20 or equivalent hardware. Hardware selection should be based on any expected shipping/transportation and operating conditions. The torque applied to the mounting hardware should not exceed 65 in-lb (7.34 N•m). Figure 4 shows SSR Retrofit dimensions in inches with millimeters in brackets. An SSR Retrofit can be installed in the same space previously occupied by a Basler Electric SSR regulator without the need for additional mounting holes and/or hardware.

Publication <b>9507900991</b>	Revision <b>D</b>	<b>Instructions</b>	Date <b>May 2025</b>	Page <b>4 of 16</b>
----------------------------------	----------------------	---------------------	-------------------------	------------------------

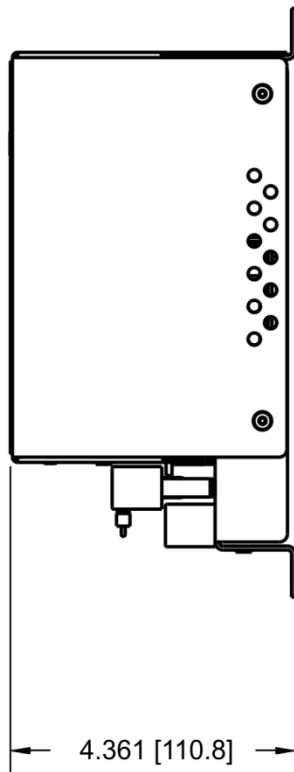
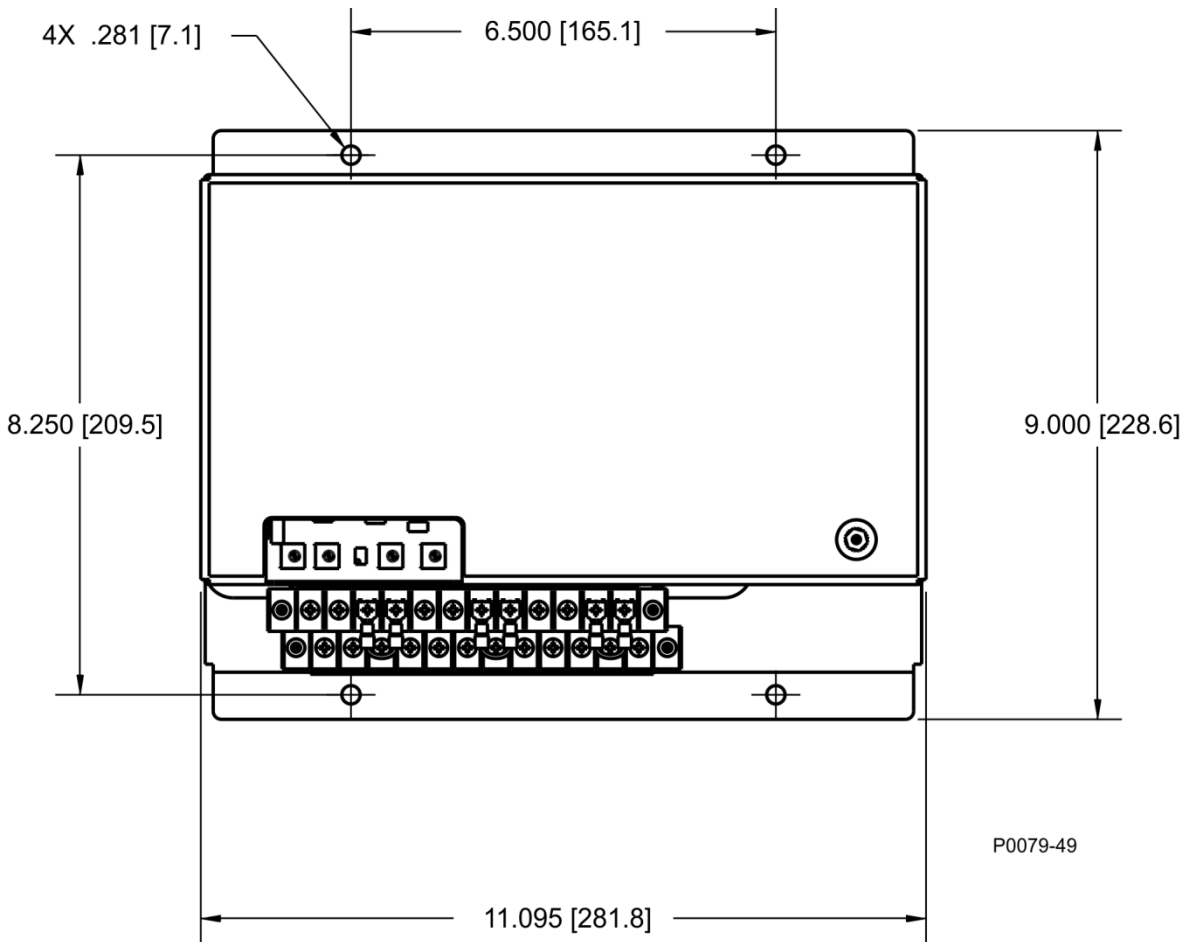

Figure 4. Mounting Dimensions

## Connections

### Internal Connections

Connections for the internal AVC regulator and sensing module are described in the following paragraphs. The cover on the SSR Retrofit must be removed to access the AVC regulator and sensing module. Use a Torx®, T10 screwdriver to remove the six screws that secure the cover. Remove the cover. After setting the unit, re-attach the cover with the six screws and tighten to 8 to 10 in-lb (0.902 to 1.128 N•m).

#### External Voltage Adjust Jumper

An internal jumper is used to enable or disable the use of an external voltage adjust rheostat. The external voltage adjust input is used when remote adjustment of the voltage is desired. When this jumper is installed, the internal VLT ADJ control is used to adjust the voltage.

Remove the jumper on AVC terminals 4 and 7 to enable external voltage adjust. Move the jumper from terminal 7 to the U-shaped quick connect on terminal 4. The U-shaped jumper serves as jumper storage should the jumper be required in the future.

See *External Voltage Adjust* under *External Connections* for information on connecting a rheostat.

#### AVC Sensing Module (480/600 Vac Sensing Only)

An internal sensing module is included with SSR Retrofits utilizing 480/600 Vac sensing. SSR Retrofits with 480/600 Vac sensing are shipped preset for 480 Vac sensing.

If your application uses 600 Vac sensing, the sensing module connections must be adjusted. To configure the unit for 600 Vac sensing, move the wire from the A1 terminal to the B1 terminal.

AVC sensing module terminals are shown in Figure 5.

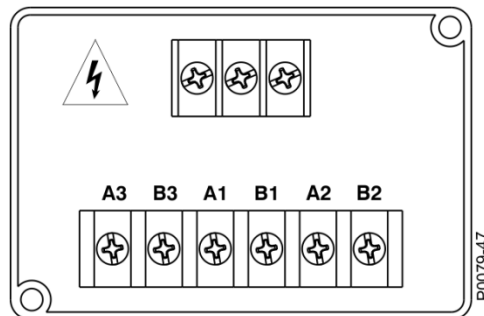

Figure 5. AVC Sensing Module Terminals

### External Connections

The SSR Retrofit must be connected to the generator system as instructed in this section and as shown in the basic interconnection diagrams (Figures 67, 7, and 8). All connections to the SSR Retrofit should be made with 16 AWG (or larger) copper wire.

#### Ground Terminal

Connect the GND terminal to earth ground. When the SSR Retrofit is configured in a system with other devices, a separate ground lead should be used for each device.

#### Regulator Sensing (Terminals E1, E2, and E3)

For single-phase sensing, the voltage sensing leads are connected to terminals E1 and E3. For three-phase sensing, terminals E1, E2, and E3 are used. For precise regulation, the sensing leads should be connected as close as possible to the point where regulation is desired. The SSR Retrofit regulates the voltage that is applied to its sensing terminals. Therefore, it cannot correct for voltage drop in leads that may occur at points other than where the regulator sensing leads are connected. The leads that supply regulator sensing should not be used to supply power to any other equipment or to the regulator power stage (terminals 3 and 4).

If the generator is to be operated in parallel with other generators, the phase relationship of the sensing voltage and the paralleling current transformer is very important. See *Parallel Compensation* for more information.

#### Field Power (Terminals F+ and F-)

The dc resistance of the field to which the SSR Retrofit is connected (terminals F+ and F-) must be equal to or greater than 5.25 ohms for models 9507900200 through 9507900202 and 12.5 ohms for models 9507900203 through 9507900205. If the field resistance is less than the specified minimum, a resistor must be added in series with the field. This resistor value plus the field resistance must exceed the minimum preceding values.

Publication <b>9507900991</b>	Revision <b>D</b>	<b>Instructions</b>	Date <b>May 2025</b>	Page <b>6 of 16</b>
----------------------------------	----------------------	---------------------	-------------------------	------------------------

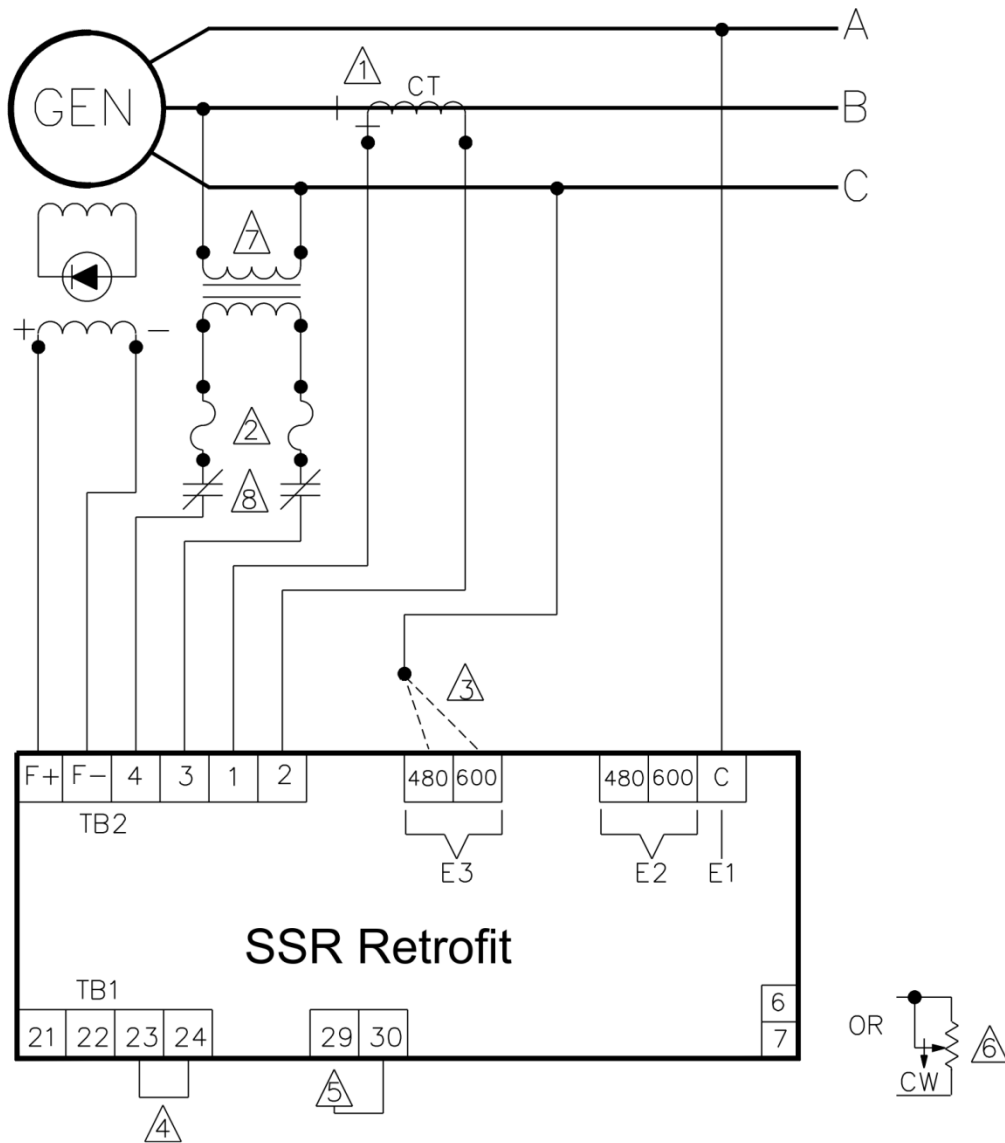

P0079-53

- △1 For A-B-C rotation, connect CT as shown. For A-C-B rotation, reverse the connections at terminals 1 and 2.
- △2 600 V, 20 A high-interrupting capacity fuses.
- △3 Connect for nominal voltage of generator (480/600 model shown).
- △4 Connect terminals 23 and 24 to accessories. Short 23 and 24 when accessories are not used.
- △5 For V/Hz, jumper terminals 29 and 30. Remove jumper for 2 per unit V/Hz.
- △6 For remote voltage adjustment, connect rheostat across terminals 6 and 7. Remove link across internal AVC terminals 4 and 7.
- △7 Power step-down transformer is required if the generator voltage does not match the voltage regulator input power range.
- △8 Refer to input power for voltage shutdown switch requirements.

**Figure 6. Typical SSR Retrofit Interconnection, Single-Phase Sensing**

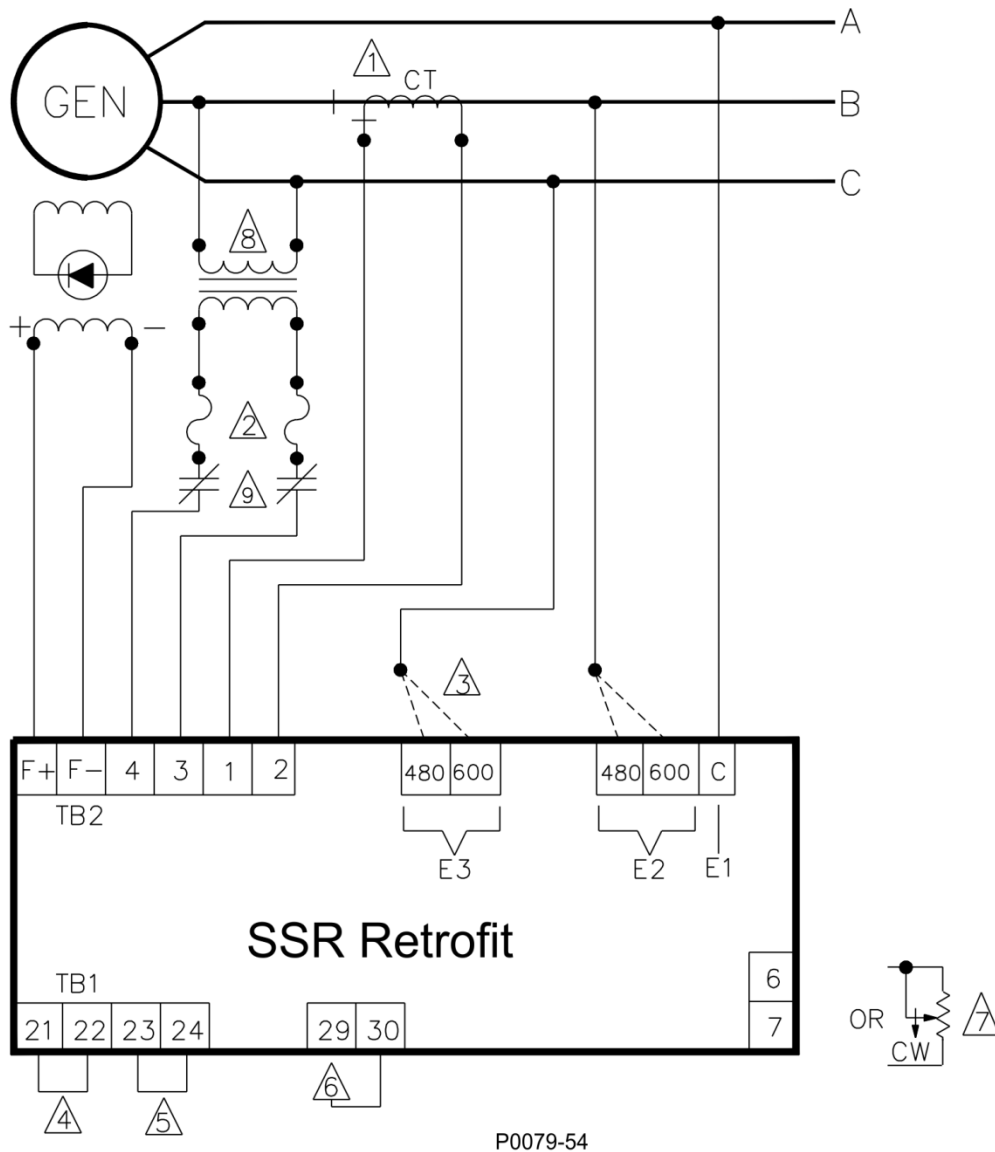

P0079-54

- ① For A-B-C rotation, connect CT as shown. For A-C-B rotation, reverse the connections at terminals 1 and 2.
- ② 600 V, 20 A high-interrupting capacity fuses.
- ③ Connect for nominal voltage of generator (480/600 model shown).
- ④ Jumper required for three-phase operation.
- ⑤ Connect terminals 23 and 24 to accessories. Short 23 and 24 when accessories are not used.
- ⑥ For V/Hz, jumper terminals 29 and 30. Remove jumper for 2 per unit V/Hz.
- ⑦ For remote voltage adjustment, connect rheostat across terminals 6 and 7. Remove link across internal AVC terminals 4 and 7.
- ⑧ Power step-down transformer is required if the generator voltage does not match the voltage regulator input power range.
- ⑨ Refer to input power for voltage shutdown switch requirements.

**Figure 7. Typical SSR Retrofit Interconnection, Three-Phase Sensing**



### Input Power (Terminals 3 and 4)

The current requirement of the field, to which the regulator is operating into, will determine the actual input current. The nominal voltage applied to the regulator input power stage (terminals 3 and 4) must be 120 V for SSR Retrofit models 9507900200 through 9507900202, and either 208 or 240 V for models 9507900203 through 9507900205. The input power may be taken from any generator lines that provide the correct voltage (line-to-line or line-to-neutral). The phase relationship of this input in relation to other circuits is not important.

When the generator output voltage is different than the preceding values and exceeds the output power specifications, a power transformer must be used to match the generator voltage to the regulator input. If excessive voltage is applied to the regulator input (terminals 3 and 4), the regulator may be damaged.

#### **Caution**

If the field or field flashing circuit is grounded, a power transformer must be used to isolate the regulator input from ground. A ground at any point in the field circuit and another ground in the generator could result in failure of the regulator.

A Basler ICRM-15 is required when energizing the SSR Retrofit from a source that is already at the regulator input power rating. Failure to apply an ICRM-15 in these applications may result in damage to the SSR Retrofit.

### Inrush Current Reduction Module

A Basler ICRM-15 is required when energizing the SSR Retrofit from a source that is already at the SSR Retrofit input power rating. The ICRM-15 minimizes the amount of inrush current that could be seen when power is applied.

### Voltage Shutdown Switch

A voltage shutdown switch may be installed to allow removal of excitation from the field in an emergency or when the generator prime mover must be operated at reduced speed. If this switch is not used, it is recommended that it be temporarily installed for the initial startup.

When used, this switch must always be installed in the input power line to the regulator (terminal 3 or 4) or in the dc field circuit (terminal F+ or F-).

### 1 or 2 Per Unit V/Hz

When this jumper is installed, the underfrequency slope is 1 per unit V/Hz. Remove the jumper on terminals 29 and 30 to enable 2 per unit V/Hz.

### Single- or Three-Phase Voltage Sensing

When this jumper is installed, the regulator is configured for three-phase sensing. Install the jumper on terminals 21 and 22 to enable three-phase sensing. Remove the provided jumper from the unused terminals located between terminals 22 and 29 and install it on terminals 21 and 22. The regulator is configured for single-phase sensing when the jumper is NOT installed on terminals 21 and 22.

### Parallel Compensation (Terminals 1 and 2)

In addition to the regulator provisions, a 25 VA current transformer (CT) is required. This CT is connected in a generator line and should deliver from 3 to 5 A secondary current at rated load.

The phase relationship of the CT signal to the regulator sensing voltage must be correct or the system will not parallel properly. For three-phase sensing, the CT must be installed in the line that supplies sensing voltage to terminal E2. For single-phase sensing, it must be installed in the line of the three-phase generator that does not supply sensing to the regulator.

### Reactive Droop Compensation (Droop)

For reactive droop compensation, connect the CT to its respective regulator as shown in Figures 6 and 7.

A unit-parallel switch shorts the parallel CT secondary to prevent any droop signal from being injected into the regulating system during single-unit operation. The switch may not be required on parallel droop compensation applications where a voltage drop is not objectionable.

### External Voltage Adjust (Terminals 6 and 7)

Voltage can be adjusted using the onboard VLT ADJ control or through the external voltage adjust input. If the external voltage adjust input will be used, connect a 2-watt, 10-k $\Omega$  rheostat across terminals 6 and 7. Refer to the interconnection diagrams (Figures 6, 7 and 8) to ensure that clockwise rotation increases the setpoint and

Publication <b>9507900991</b>	Revision <b>D</b>	<b>Instructions</b>	Date <b>May 2025</b>	Page <b>10 of 16</b>
----------------------------------	----------------------	---------------------	-------------------------	-------------------------

counter-clockwise rotation decreases the setpoint. See *External Voltage Adjust* under *Internal Connections* for information on enabling external voltage adjust.

**Reactive Differential Compensation (Cross Current)**

In parallel reactive differential compensation applications, a contact should be used to short out the paralleling CT secondary when the generator is not paralleled to the bus. If the switch is not used, a voltage drop will be introduced into the system. This is due to the unloaded generator parallel CT not supplying its compensating signal, but allowing a voltage drop to occur across it. Lack of this shorting contact will also cause the voltage of the incoming generator to fluctuate prior to paralleling. Ideally, this contact is an auxiliary on the circuit breaker contactor that opens when the circuit breaker is closed.

For reactive differential compensation, connect each CT to its respective regulator. Then connect the finish of the first CT to the start of the second CT, the finish of the second CT to the start of the third CT, and so on. Continue until all CTs are connected in series. The final step is to connect the finish of the last CT to the start of the first CT. See Figure 9.

The SSR Retrofit does not require external burden resistors when connected in a cross-current configuration with other SSR regulators. The burden adjust control adjusts the burden up to 10 VA.

Reactive differential compensation cannot be used when paralleled with the utility or any infinite bus. If this compensation system is used, a switching circuit must be used to convert the system to a reactive droop compensation system. Contact Basler Electric for additional information.

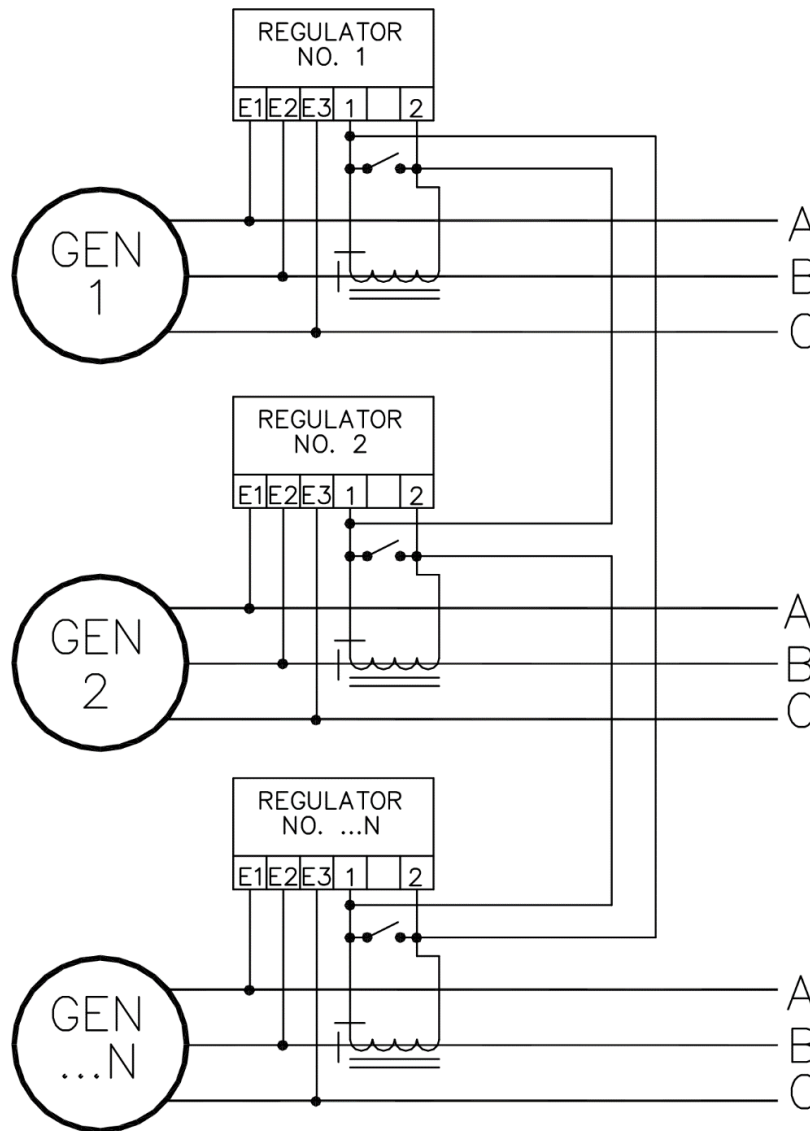

P0079-44

**Figure 9. Reactive Differential (Cross-Current) Compensation CT Interconnection**

## Accessory Input

The accessory input provides support for the EL 200, SCP 250, and BE3-25A.

Remove the jumper on terminals 23 and 24. Connect wires from terminals 23 and 24 to the proper terminals on the accessory unit as shown in Figure 10. When the accessory input is not used, the jumper must be installed on terminals 23 and 24.

Figure 10 illustrates the internal AVC regulator, EL 200, SCP 250, BE3-25A interconnection.

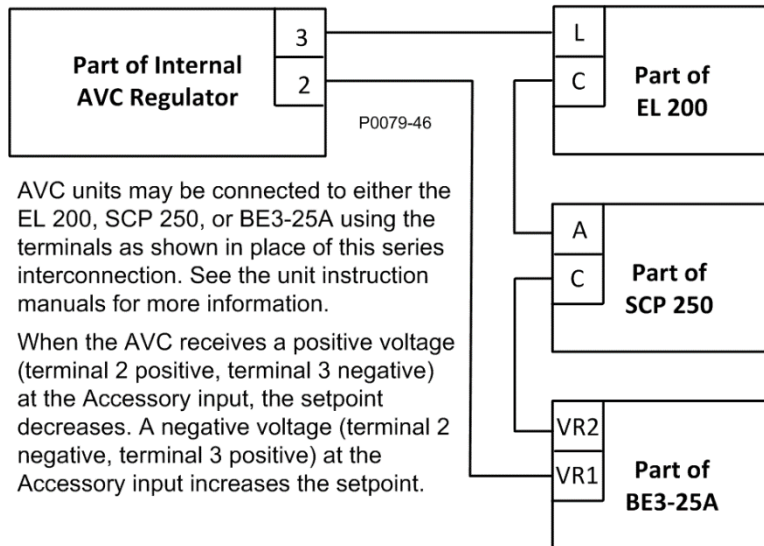

Figure 10. Interconnection with EL 200, SCP 250, and BE3-25A

## Controls and Adjustments

SSR Retrofit controls are located on the front panel. See Figure 11. SSR Retrofit controls and adjustments are described in the following paragraphs.



Figure 11. SSR Retrofit Controls

### A. DRP – Parallel Droop Compensation

Variable parallel droop compensation levels can be obtained by adjusting the DRP control. Clockwise rotation increases the amount of droop for a given condition.

#### Line Drop Compensation

When the sensing input CT connections are reversed to provide line drop compensation, the droop adjustment becomes the line drop compensation adjustment.

### B. FAC CAL – Factory Calibration

#### Caution

The FAC CAL control is intended for use during factory calibration only. The following procedure can be used if the factory calibration has been disturbed.

1. With the regulator operating on a generator, adjust the FAC CAL control fully counterclockwise and the external voltage adjust control fully clockwise.
2. Adjust the FAC CAL control clockwise until the generator voltage reaches the desired maximum voltage setting. The regulator is calibrated and the FAC CAL control can be sealed.

### C. VLT ADJ – Voltage Adjust

Installation of a jumper across terminals 4 and 7 on the internal AVC regulator enables the front-panel VLT ADJ control to vary the generator nominal voltage over the operating range. Refer to *Connections* for information on setting the internal jumper.

### D. UF KNEE – Frequency Rolloff

The underfrequency knee (rolloff) is typically set below the nominal system frequency. When the generator speed falls below the knee setpoint of the regulator, generator voltage is reduced proportionally to the speed of the machine. To adjust the underfrequency knee, perform the following steps.

1. Adjust the generator frequency at the nominal level (50, 60, or 400 Hz).
2. Adjust the UF KNEE control fully counterclockwise.
3. Adjust the VLT ADJ control for nominal generator voltage.
4. Adjust the UF KNEE control clockwise until the voltage begins to decrease.
5. Adjust the UF KNEE control counterclockwise until the voltage just returns to the value set in step 3.

The underfrequency knee is now set just below the nominal operating frequency. Further rotation in the counterclockwise direction will lower the knee frequency setpoint at which underfrequency compensation just begins.

Connecting a jumper from terminal 29 to 30 on the SSR Retrofit will provide an underfrequency slope of 1 per unit V/Hz. No connection to terminal 29 will result in an underfrequency slope of 2 per unit V/Hz. Refer to *Connections* for information on setting the internal jumper.

### E. STB – Stability

An oscilloscope or other voltage recording device should be used if an optimal stability setting is desired. Adjust the stability setting with the generator at no load.

Clockwise rotation of the STB control will slow response time. Counterclockwise rotation will speed response time. If rotated too far counterclockwise, the generator voltage may oscillate (hunt).

To obtain good response, rotate the STB control counterclockwise until the system just begins to oscillate. Then, rotate the control clockwise just past the point where oscillation occurred. Apply various amounts of load to determine proper stability performance.

### F. Burden Adjust

The burden of the SSR Retrofit is adjustable up to 10 VA when connected to other SSRs in a cross-current configuration. Clockwise rotation increases the burden.

### Startup

A startup and troubleshooting procedure for the SSR Retrofit is listed in the following paragraphs. Symptoms of startup problems stemming from improper regulator adjustments and certain generator system problems that resemble faulty regulation are listed with possible solutions. Simplifying the system by eliminating components, such as remote adjustment potentiometers and other nonessential items, can be helpful in the troubleshooting process.

1. Ensure that the regulator has been installed in accordance with the *Mounting* and *Connections* paragraphs before proceeding with system startup.
2. Start the prime mover and bring it up to rated speed.  
If the voltage does not build up:
  - a. Flash the field.
  - b. Remove power for one minute to reset the overexcitation circuit.
3. Slowly adjust the VOLT ADJ potentiometer or external, voltage adjust rheostat until the voltage reaches nominal.  
If the voltage will not build up to the rated voltage, check the generator output for a shorted or excessive load.
4. Apply and remove the generator load to check stability.  
If the generator response is too slow or is hunting (oscillating):
  - a. Check the generator output for a shorted or excessive load. Adjust the STB potentiometer with no load applied.

- b. Check stability of the governor.
5. Check regulation under normal operating conditions.  
If the regulation is poor:
- a. Check that the prime mover is up to rated speed.
  - b. Check that the voltmeter is connected at the same point as the regulator sensing.
  - c. Use an average-sensing voltmeter (not an rms-sensing voltmeter).
6. Reduce the generator frequency. The generator output should decrease from this point.  
If the generator output voltage does not decrease at the desired frequency:
- a. Check that all wiring is in accordance with the connection diagrams provided in this instruction sheet.
  - b. Adjust the UF KNEE control.

## Accessories

The following accessories are available for use with the SSR Retrofit. Information covering these accessories may be obtained by consulting the applicable instruction manual and product bulletin, or by contacting your nearest Basler Electric Sales representative or the factory.

Refer to *Connections* for information on setting internal jumpers and connecting wires to the accessory input on the SSR Retrofit.

### ICRM-15 Inrush Current Reduction Module

A Basler ICRM-15 is required when energizing the SSR Retrofit from a source that is already at the SSR Retrofit input power rating. The ICRM-15 minimizes the amount of inrush current that could be seen when power is applied.

### External Voltage Adjust

The optional external voltage adjust is used when remote adjustment of the voltage is desired. The 5 k $\Omega$  rheostat previously used with the SSR cannot be used with the SSR Retrofit. If the external voltage adjust input will be used, replace the 5 k $\Omega$  rheostat with a 2 watt, 10 k $\Omega$  rheostat.

### SCP 250 Var/Power Factor Controller

The Basler SCP 250 controls generator power factor or vars by monitoring the voltage and current and supplying a control input to the accessory input on the SSR Retrofit.

When the SCP 250 is controlling vars, the voltage regulator output changes to attain the selected reactive load current. When the SCP 250 is controlling power factor, the voltage regulator adjusts the excitation until the selected power factor is obtained.

The SCP 250 monitors the open/closed state of the circuit breaker so that the voltage regulator controls excitation when the breaker is open and the SCP 250 controls excitation when the breaker is closed.

### EL 200 Excitation Limiter

The Basler EL 200 performs two functions. As a maximum excitation limiter, it senses the field current output of the voltage regulator and limits the field current to prevent overheating of the field. As a minimum excitation limiter, it senses the leading reactive power (var) output of the generator and limits any further decrease in excitation (as necessary) to prevent loss of synchronization and end iron heating during parallel operation.

When the minimum or maximum excitation level is exceeded, the EL 200 provides a signal into the accessory input on the SSR Retrofit to change the excitation level.

### EDM-200 Exciter Diode Monitor

The Basler EDM-200 connects to the exciter field circuit and monitors the output of the brushless exciter power semiconductors. The EDM-200 can detect and open or shorted power rectifier in a brushless exciter. A set of Form C contacts provides alarm annunciation. A bar graph display enables easy onsite calibration and monitoring of EDM-200 operation.

### BE3-25A Auto Synchronizer

The Basler BE3-25A, equipped with voltage matching and a summing point output, provides precise matching of the generator voltage to the bus prior to synchronization.

The BE3-25A provides a bipolar correction signal to the accessory input on the SSR Retrofit when the voltage difference between the generator and bus exceeds the front panel setting. This bipolar correction signal is proportional to the magnitude of the monitored voltage difference.

Publication	Revision	<i><b>Instructions</b></i>	Date	Page
<b>9507900991</b>	<b>D</b>		<b>May 2025</b>	<b>14 of 16</b>

## MVC 112 Manual Voltage Control

The Basler MVC 112 provides a method for manually controlling the generator output during generator startup and commissioning or in the unlikely event of a regulator failure.

## SBO Excitation Support System

The Basler SBO provides motor starting and fault clearing capabilities for a generator with a brushless exciter. The Excitation Support System enables a brushless generator to be used in an application that would normally require a conventional generator with a brush-type rotary or series-boost exciter.

## CBS 212A Current Boost System

With the Basler CBS 212A installed, if the generator output voltage decreases below the preset operating point due to a short-circuit or large motor starting, the CBS 212A provides full current boost to the generator exciter until the voltage returns to a level just above the operating point.

## Operational Test

This test verifies regulator operation. Table 2 lists each SSR Retrofit model and the corresponding test voltage and frequency.

**Table 2. Test Voltage and Frequency**

SSR Retrofit Model	Input Power	Sensing Voltage
9507900200	90–153 Vac, 50–400 Hz	90–139 Vac, 50/60 Hz
9507900201	90–153 Vac, 50–400 Hz	180–264 Vac, 50/60 Hz
9507900202	90–153 Vac, 50–400 Hz	432–528 Vac (480 nominal), 50/60 Hz 540–660 Vac (600 nominal), 50/60 Hz
9507900203	180–264 Vac, 50–400 Hz	90–139 Vac, 50/60 Hz
9507900204	180–264 Vac, 50–400 Hz	180–264 Vac, 50/60 Hz
9507900205	180–264 Vac, 50–400 Hz	432–528 Vac (480 nominal), 50/60 Hz 540–660 Vac (600 nominal), 50/60 Hz

To test regulator operation, perform the following steps:

1. Connect the SSR Retrofit according to Figure 12 and apply the appropriate voltages.

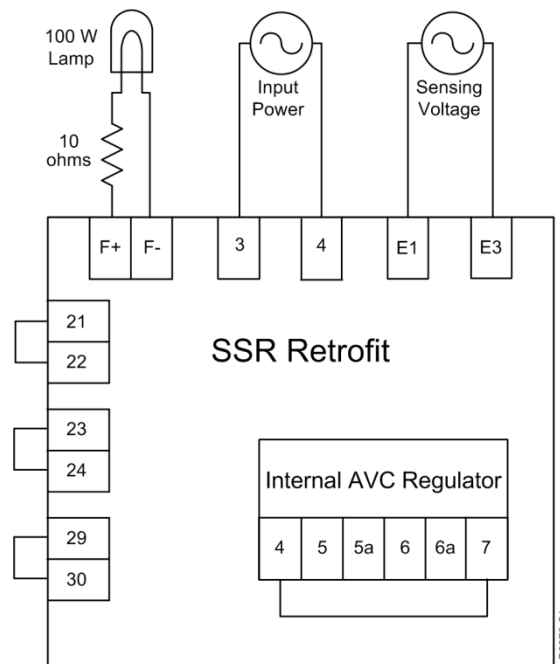

**Figure 12. Test Setup**

2. Adjust the VLT ADJ control fully counterclockwise. Observe that the lamp is off.
3. Adjust the VLT ADJ control clockwise. Observe that the lamp turns on.
4. Adjust the VLT ADJ control until the lamp just turns off.

Regulator operation is satisfactory if the above results are obtained. However, stability must be tested with the generator and regulator in operation.

### **Maintenance**

---

A periodic inspection of the regulator should be made to ensure that it is clean and free from accumulations of dust and moisture. Ensure that all connections are clean and tight.

Publication <b>9507900991</b>	Revision <b>D</b>	<b><i>Instructions</i></b>	Date <b>May 2025</b>	Page <b>16 of 16</b>
----------------------------------	----------------------	----------------------------	-------------------------	-------------------------