

INTRODUCTION

The Basler Electric SGC-250 Synchronous Generator Controller precisely and reliably supplies and controls the level of excitation power to a brushless-excited synchronous generator. Field excitation power is delivered and controlled by a DECS-250 Digital Excitation Control System.

A dual DECS-250 option provides continued operation in the event of a failure. The protection and control features of the DECS-250 can be augmented by an optional BE1-11g Generator Protection System.

All SGC-250 components and connection terminals are mounted and wired on a single mounting plate or pan chassis intended for installation in a suitable enclosure.

This publication serves as an overview of the functions and capabilities of the SGC-250. System drawings and product documentation specific to the devices of the SGC-250 accompany this publication.

SAFETY

Warning!

Personal injury may result if contact is made with system components carrying high voltages. The circuit diagrams, supplied with this document will disclose hazardous areas.

As with all electrical equipment, appropriate safety measures must be taken whenever dealing with the excitation equipment. High voltages are present at the equipment. The voltage magnitudes depend upon the characteristics of a particular system. Opening the power source connections does not completely remove the threat of high voltages. As long as the machine is physically connected to the system, the possibility of a safety hazard exists.

When working with the excitation control switchgear, every precaution must be taken to ensure that all high voltages are isolated and avoided. In addition to voltage at the PPT, there may be other power sources connected to the equipment. These sources may include the user-supplied dc control power and the ac station power. Consider all connections to be live and dangerous until proven otherwise.

SPECIFICATIONS

Operating Power Input (1- or 3-Phase)

Full-load continuous field voltage:

32 Vdc:	56 to 70 Vac
63 Vdc:	100 to 139 Vac or 125 Vdc
125 Vdc:	190 to 277 Vac or 250 Vdc

Frequency Range: 50 to 420 Hz

Control Power Input

120 Vac nominal, style Sxxxx1xxx:

Voltage:	82 to 132 Vac
Frequency:	50/60 Hz

24 Vdc nominal, style Sxxxx2xxx:

Voltage:	16 to 26 Vdc
----------	--------------

Sensing Inputs

Voltage (1- or 3-phase)

50 Hz:	100 Vac (90 to 110 Vac)
60 Hz:	120 Vac (108 to 132 Vac)

Current (1- or 3-phase)

Nominal:	1 or 5 Aac
----------	------------

Contact Outputs (DECS-250)

Make, break, and carry ratings (resistive):

24 Vdc:	7.0 Adc
120 Vdc:	7.0 Adc

Temperature

Operating:	0 to 50°C (32 to 122°F)
Storage:	-20 to 60°C (-4 to 140°F)

FCC Requirements

This product complies with FCC 47 CFR Part 15.

HANDLING AND MAINTENANCE

Careful handling and routine maintenance will promote SGC-250 longevity and preserve its performance. Basler Electric publication 9410100990, supplied with this document, provides guidelines for handling, installing, and maintaining the SGC-250.

EQUIPMENT OVERVIEW

SGC-250 features and options are defined and specified by a style number derived from the style chart shown in Figure 1.

Standard equipment elements include a DECS-250 Digital Excitation Control System, auxiliary relays/contactors, field flashing components, a metering shunt, circuit breakers, an isolation transformer, and user terminals.

MOUNTING CONFIGURATIONS

The variables that affect the size and weight of the SGC-250 are:

- Single or dual DECS-250 controllers,
- With or without BE1-11g protection,
- Mounting plate or pan chassis mounting configuration, and
- 120 Vac/125 Vdc or 24 Vdc/120 Vac control power.

SGC-250 dimensions and weights for each configuration are listed in Table 1.

The SGC-250 mounting plate is constructed from 1.5-millimeter galvanized steel. The pan chassis is constructed from 11-gauge steel and finished with a light-gray, thermoset polymer coating.

TERMINAL CONFIGURATIONS

One of two SGC-250 terminal configurations may be specified. User connections to the SGC-250 are made with spring terminals (style xxxxxxxS) or compression (screw) terminals (style xxxxxxxC). Both terminal types accommodate wire sizes over the range of 24 to 12 AWG or 0.2 mm² to 2.5 mm². When wiring to spring terminals or compression terminals, a wire insulation stripping length of 8 to 10 millimeters (0.315 to 0.394 inches) is recommended.

When tightening the connection screws of compression terminals, apply a torque no greater than 0.6 N•m or 5.3 in-lb.

OPTIONAL EQUIPMENT

Optional equipment may include a second DECS-250, a BE1-11g Generator Protection System, DECS-250 expansion modules, or a touchscreen display panel.

Redundant DECS-250

A dual DECS-250 option, specified by style Dxxxxxxx, provides continued operation in the event of a failure. The DECS-250's autotracking capability enables the secondary DECS-250 to track the operating setpoint of the primary DECS-250. This makes for a "bumpless" transfer from the primary DECS-250 to the secondary DECS-250 in the event of a primary DECS-250 failure.

BE1-11g

DECS-250 protection and control features can be augmented by specifying the optional BE1-11g Generator Protection System. The BE1-11g has extensive and flexible protection, control, and measuring functions that can be tailored to your application. Its sync-check function can be used to supervise automatic synchronizing of the generator by the DECS-250. Other features include oscillography and sequential event recording, Ethernet communication, and programmable contact inputs and

outputs. Optional current differential protection is available. BESTCOMSP^{Plus}, provided with the BE1-11g, provides a graphical interface for configuring your application's protection and control needs. The integrated BESTlogic™*Plus* programmable logic system enables application of BE1-11g functions to meet the requirements of the generator system.

Information about applying the BE1-11g is available in Basler publication 9424200772 (Quick Start Guide), 9424200994 (device manual), 9424200773 (DNP protocol manual), and 9424200774 (Modbus™ communication protocol manual).

DECS-250 Expansion Modules

Optional expansion modules provide additional inputs and outputs for use with the DECS-250. Module input and output status/values are communicated to/from the DECS-250 over the DECS-250 SAE J1939 CAN interface.

CEM-125 and CEM-2020

The optional CEM-125 and CEM-2020 both provide ten programmable contact inputs and twenty-four programmable contact outputs with the same available functionality as the contact inputs of the DECS-250. The CEM-125 is rated for 125 Vdc applications, while the CEM-2020 is rated for 12 or 24 Vdc applications.

CEM-125 and CEM-2020 contact assignments are made using the BESTlogic*Plus* programmable logic of BESTCOMSP^{Plus}.

Details about the CEM-125 are available in Basler publication 9636500990. Details about the CEM-2020 are available in Basler publication 9440300990.

AEM-2020

The optional AEM-2020 provides eight additional analog inputs, eight RTD inputs, two thermocouple inputs, and four analog outputs. AEM-2020 input and output functions are assigned using the BESTlogic*Plus* programmable logic of BESTCOMSP^{Plus}.

Details about the AEM-2020 are available in Basler publication 9440300990.

Interactive Display Panel (IDP-801)

A 7.5-inch (19 centimeter) touchscreen can be installed locally or remotely to:

- View analog and digital system parameters
- Configure generator control, limiter, and protection settings
- Download system data recorded by the DECS-250

Details about the IDP-801 are available in Basler publication 9437600991.

Publication	Revision	Instructions	Date	Page
9479600990	H		Jun 2025	2 of 8

SYSTEM ELEMENTS

Interconnected SGC-250 system elements work together to supply regulated excitation power to the field and protect the controlled equipment. All excitation system element connections are illustrated on the system interconnection diagrams.

Digital Excitation Control System DECS-250

The DECS-250 supplies regulated excitation power to the machine field. It also monitors parameters to control, limit, and protect the machine from operating beyond its capabilities.

The following paragraphs serve as an overview of DECS-250 functions. Detailed information about DECS-250 operation is available in Basler publication 9440300990.

Regulation

Machine parameters are monitored by the DECS-250 through sensing PTs and CTs. Field voltage and current are monitored directly by the DECS-250 through its excitation power output. The DECS-250 compares these monitored parameters with the system setpoint and supplies regulated excitation power to the field. The use of digital signal processing and precise regulation algorithms enables the DECS-250 to accurately regulate the level of excitation.

Multiple regulation modes enable the DECS-250 to accommodate a variety of machine applications and operating conditions.

Auto Mode

Auto mode regulates the generator rms voltage to within 0.25% of the setpoint over the range of no-load to full-load. Operation in Auto mode makes either of two control modes available: Var or Power Factor.

When operating in Var mode, the DECS-250 regulates the level of reactive power supplied by the generator.

In Power Factor mode, the DECS-250 controls the level of vars supplied by the generator to maintain a specific power factor despite a varying generator kW load.

Manual Mode

In Manual mode, the DECS-250 regulates the level of excitation power supplied to the machine field independently of all operating conditions. This makes Manual mode useful as a backup method of excitation control if a loss of sensing occurs. Manual mode can be configured for field current regulation (FCR) or field voltage regulation (FVR).

When operating in FCR mode, the DECS-250 regulates only the level of supplied dc excitation current. The operator must manually vary the FCR setpoint in order to achieve the desired operating conditions.

FVR mode operates similarly to FCR mode except that the DECS-250 regulates the level of field voltage. FVR mode enables the user to perform generator modeling and validation testing. It can also be used to smooth the transfer from the active exciter to a backup exciter.

Autotracking

The setpoint of the active control mode is automatically tracked (followed) by the inactive control modes. In dual DECS-250 systems, the secondary DECS-250 tracks the setpoint of the primary DECS-250. This feature enables the initiation of “bumpless” transfers between operating modes and DECS-250 controllers.

Field Flashing

The field flashing circuit may be used to rapidly build generator output voltage and initiate system operation. Flashing power from an external source is automatically applied and removed by the DECS-250. The DECS-250 applies flashing until the generator voltage increases above an adjustable threshold setting or until an adjustable time delay expires.

Soft-Start Voltage Buildup

The adjustable soft-start feature controls the buildup rate of the generator voltage to prevent voltage overshoot during generator startup. Soft start is active in both Auto and Manual modes.

Limiters

Limiters restrain machine operation to avoid unsafe conditions and machine insulation degradation. The DECS-250 has limiters for overexcitation, underexcitation, stator current, reactive power, and underfrequency or volts per hertz.

Overexcitation Limiter (OEL)

If the level and duration of current applied to the field exceeds the OEL settings, the DECS-250 will stop further increases in field current and lower the current to a safe level for the machine. The OEL operates at three levels to permit short-term var boosting that could be beneficial for the application.

Underexcitation Limiter (UEL)

Pole slip is prevented by limiting the amount of reactive power absorbed by the machine. The UEL compares the level of real power (kW) with the level of reactive power (kvar). A decrease in kvar causes the DECS-250 to increase excitation to maintain synchronism (and prevent pole slip).

Stator Current Limiter (SCL)

The SCL prevents stator overheating by modifying the excitation level according to the direction of var flow into or out of the generator. High stator current with leading power factor initiates increased excitation while high stator current with lagging power factor initiates reduced excitation.

Publication	Revision	Instructions	Date	Page
9479600990	H		Jun 2025	3 of 8

Low and high thresholds are available. Continuous operation is possible at the low threshold while a programmable limiting delay is implemented at the high threshold.

Reactive Power Limiter

The reactive power limiter restricts the level of vars exported from the generator to a predefined level.

Underfrequency Limiter

The underfrequency limiter is selectable for under-frequency limiting or volts per hertz limiting. These limiters protect the generator from damage due to excessive magnetic flux resulting from low frequency and/or overvoltage.

Synchronizer

An SGC-250 with style number xD3xxxxxx or xD4xxxxxx is equipped with an DECS-250 that has an automatic synchronizer. The automatic synchronizer acts to align the generator voltage, phase angle, and frequency with that of the bus. Two modes of synchronization are available: anticipatory or phase lock loop. Compensation settings for the generator breaker and bias control settings for the generator governor are provided.

Protection

DECS-250 protective functions may be implemented as backup to the primary protection relays used in an application. Each protection feature has an adjustable tripping level and time delay and can be assigned to one of the DECS-250 programmable contact outputs. DECS-250 protective functions include:

- Configurable protection
- Exciter diode monitor
- Field overcurrent
- Field overvoltage
- Generator overvoltage
- Generator undervoltage
- Loss of excitation
- Loss of sensing voltage
- Low generator frequency
- Overfrequency
- Power input failure
- Reverse power
- Sync-check
- Underfrequency

Operating Logic

In the SGC-250, the DECS-250 is preconfigured with operating logic for a synchronous generator application. If desired, this logic scheme can be customized by using the logic programming capabilities of BESTlogicPlus. The BESTlogicPlus chapter of Basler publication 9440300990 provides information about customizing DECS-250 logic.

PSS

An SGC-250 with style number xD2xxxxxx or xD4xxxxxx is equipped with a DECS-250 that has a

power system stabilizer (PSS). The PSS is a dual-input, IEEE type PSS2A stabilizer that utilizes the “integral of accelerating power” algorithm.

Stability Setting Groups

Two sets of PID (proportional + integral + derivative) settings optimize performance under two distinct operating conditions. For example, one set of stability settings can be used with the optional PSS in service and one set can be used when the PSS is not in service. Fast controller response settings would give optimum transient performance when the PSS is enabled. Slower controller response settings would provide improved damping of first-swing oscillations when the PSS is offline.

Event Recorder

DECS-250 event recorder functions include sequence-of-events recording, data logging, (oscillography), and trending.

Sequence of Events

The sequence of events recorder monitors the internal and external status of the DECS-250. A maximum of 1,023 changes of state are time-and date-stamped and stored in a record.

Data Logging

Up to six oscillography records are logged in nonvolatile memory using the COMTRADE format. Logging of records is triggered by status changes in up to six user-selected parameters.

Trending

The trend log records the activity of up to six user-selected DECS-250 parameters over an extended period of time.

Communication

The DECS-250 is equipped with five communication ports. Each port is dedicated to a specific function. Optional PROFIBUS communication is available through a DB-9 port.

The front-panel, Type-B USB port is intended for local, short-term communication with a PC operating BESTCOMSPPlus software. BESTCOMSPPlus is a Windows-based application used to program and customize the DECS-250. BESTCOMSPPlus also has metering screens for viewing machine and system parameters and control screens for control of the excitation system. An integrated PID calculator simplifies selection of stability settings. An integrated, automatic tuning feature reduces system commissioning time while ensuring excellent system performance.

A DB-9 (RS-232) port provides communication with a second DECS-250.

Modbus™ RS-485 RTU and Modbus/TCP Ethernet ports support simultaneous, polled communication with other networked devices.

Publication	Revision	Instructions	Date	Page
9479600990	H		Jun 2025	4 of 8

A CAN interface uses the SAE J1939 messaging protocol to communicate with optional DECS-250 modules such as the CEM-125 or CEM-2020 Contact Expansion Module and the AEM-2020 Analog Expansion Module. A second CAN interface enables communication between the DECS-250 and a generator controller such as the DGC-2020.

Ethernet communication is provided through a copper (100Base-T) port. The Ethernet port uses the Modbus TCP protocol for communication of DECS-250 metering, annunciation, and control commands.

DC Millivolt Sensing Relay (ES-74S)

The ES-74S monitors the level of exciter field current through metering shunt SH1 and functions as an overexcitation relay. The relay setpoint is adjustable over the range of 40 to 120% of SH1's rating. A time delay for the setpoint prevents nuisance tripping during transient disturbances. When an overexcitation condition is detected, the ES-74S trips and closes the SGC-250 Extended Overexcitation output contacts.

Details about the ES-74S are provided in Basler publication 9500100994.

Inputs and Outputs

SGC-250 inputs and outputs consist of power and sensing inputs, control inputs and outputs, the field output, and communication ports. For input and output connections, refer to the appropriate interconnection diagram provided with this publication.

Control Power

Control power is determined by the SGC-250 style number and can be 120 Vac/125 Vdc (style xxxxx1xxx) or 24 Vdc/120 Vac (style xxxxx2xxx). Both options provide for simultaneous application of ac and dc control power to the DECS-250 for redundancy.

Operating Power

SGC-250 operating power is typically supplied by an external PPT or PMG sized for the application.

Sensing Inputs

SGC-250 sensing voltage and sensing current are supplied by external PTs and CTs configured to supply three-phase generator sensing. The PTs and CTs must be sized appropriately for the application and compatibility with the SGC-250. The DECS-250 must be configured with the PT and CT ratings prior to commissioning. Basler publication 9440300990 provides information about configuring the DECS-250 sensing transformer ratings.

Control Inputs

SGC-250 control inputs are typically received from remotely-located control switches and contact inputs from external devices. The SGC-250 has preprogrammed control inputs that can be configured at the discretion of the user. All control input connections are made at the SGC-250 plate/chassis

terminal blocks. Refer to the appropriate interconnection diagram for control input functions and terminal assignments.

Start Input

Applying a Start input enables the DECS-250 which closes the DECS-250 On/Off and Field Flash Enabled outputs.

The DECS-250 On/Off output energizes AC Shutdown Contactor K3 through the contacts of circuit breaker CB1. K3 applies operating power to the DECS-250 from an external power source.

The DECS-250 Field Flash Enabled output energizes Field Flashing Relay K1 which builds generator output voltage by applying 125 Vdc flashing power to the field. Flashing power is obtained from an external source. Field Flashing Resistor R1 can be adjusted to limit the flashing current to the appropriate level for your application. Flashing power is applied until the level of generator terminal voltage increases above the DECS-250 field flash dropout level setting or until the DECS-250 field flash time setting expires.

Stop Input

Applying a Stop input disables the DECS-250 which opens the DECS-250 On/Off output. This de-energizes K3 which disconnects the DECS-250 from its operating power source.

The contacts of a user-supplied lockout (86) device may be connected across the Stop control input to disable the system during a fault or lockout condition.

AVR/FCR Inputs

Applying an AVR (automatic voltage regulation) mode input enables automatic regulation of the excitation setpoint by the DECS-250 in order to maintain the desired generator output.

Applying an FCR (field current regulation) mode input selects manual regulation of the field excitation level independently of all generator conditions.

Var/Power Factor Input

Opening the var/PF control input enables the DECS-250 to control the generator reactive power in either the var or power factor mode (if enabled in BESTCOMSP^{lus} software). The var/PF input takes priority over the unit/parallel input; if both inputs are open, the DECS-250 will operate in var/PF mode.

Unit/Parallel Input

Opening the unit/parallel control input enables parallel operation and the DECS-250 operates in reactive droop compensation mode. The var/PF input takes priority over the unit/parallel input; if both inputs are open, the DECS-250 will operate in var/PF mode.

Raise/Lower Input

Applying a contact input to the raise or lower control input raises or lowers the setpoint of the active system regulation mode.

Publication	Revision	Instructions	Date	Page
9479600990	H		Jun 2025	5 of 8

Reset Input

Two reset control inputs are available. A reset switch or contact can be connected for reset of DECS-250 alarms and the system's extended overexcitation annunciation. A second reset switch can be connected for reset of only the DECS-250 alarms.

Lockout Input

The contact of a lockout (86) device is connected to terminals TB1-54 and 55 for disabling of the SGC-250 during a lockout condition flowing a fault. A lockout condition prevents the DECS-250 from energizing AC Shutdown Contactor K3 which applies operating (bridge) power to the DECS-250.

Accessory Inputs

Two accessory inputs accept analog signals for auxiliary control of the DECS-250 regulation setpoint. These inputs may also be used for limiter scaling and PSS control (if equipped).

The current-controlled accessory input accepts a 4 to 20 mA_{dc} control signal. The voltage-controlled accessory input accepts a ±10 V_{dc} control signal. Only one accessory input may be used at a time. Accessory input wiring should be made using shielded, twisted-pair cable. A ground connection is provided for the cable shield.

Control Outputs

SGC-250 control outputs consist of preprogrammed output contacts and fixed-function output contacts. All control output connections are made at the SGC-250 plate/chassis terminal blocks. Refer to the appropriate interconnection diagram for control output functions and terminal assignments.

Manual Mode Active

The Manual Mode Active output contacts close when the SGC-250 is operating in FCR (field current regulation) mode as selected by the FCR control input.

Common Alarm

Any active DECS-250 alarm will close the Common Alarm output contacts. (DECS-250 instruction manual 9440300990 contains information about the possible DECS-250 alarms.) once an alarm condition subsides, a reset control input can be applied to clear the annunciation.

General Protection

The General Protection output contacts close when any one of the following DECS-250 protection functions are active: generator undervoltage (27) or overvoltage (59), generator underfrequency (81U) or overfrequency (81O), directional overpower (32R), loss of excitation (40Q), field overvoltage or overcurrent, open or shorted exciter diode, or DECS-250 operating power failure.

General Limiting

The General Limiting output contacts close when the following DECS-250 limiters are active: overexcitation,

underexcitation, stator current, reactive power (var), underfrequency or volts per hertz, or regulation setpoint.

Loss of Sensing

A loss of generator sensing voltage or current from the user-supplied sensing PTs or CTs will close the Loss of Sensing output contacts.

DECS-250 Failure

The SPDT (Form C) DECS-250 Failure output contacts change state when DECS-250 control power is lost or normal execution of DECS-250 firmware ceases.

Extended Overexcitation

The Extended Overexcitation output contacts latch closed when abnormally high field current is present for an extended period of time. During this condition, the DC Millivolt Sensing Relay (ES-74S) trips and energizes Overexcitation Relay K32 after the time delay of timing module TD1 expires. When energized, K32 closes the Extended Overexcitation output contacts.

Once an extended overexcitation condition is cleared, a reset control input can be applied to clear the annunciation.

Field Output

To obtain optimum metering resolution of the field current, one of the three field output ranges may be specified to suit the application requirements. Excitation current ranges of 1 to 4 Adc (style xxxxxxAxx), 4 to 8 Adc (style xxxxxxBxx), or 8 to 20 Adc (style xxxxxxCxx) are possible.

Communication Provisions

Optional accessory devices communicate with the SGC-250 via the Ethernet port of the DECS-250 or optional BE1-11g.

Additional communication capability is provided by a DECS-250 RS-485 communication port which uses the Modbus™ RTU protocol.

SPARE PARTS

A reasonable stock of spare parts will minimize downtime in the event of an equipment malfunction. A list of recommended spare parts accompanies this publication.

Publication	Revision	Instructions	Date	Page
9479600990	H		Jun 2025	6 of 8

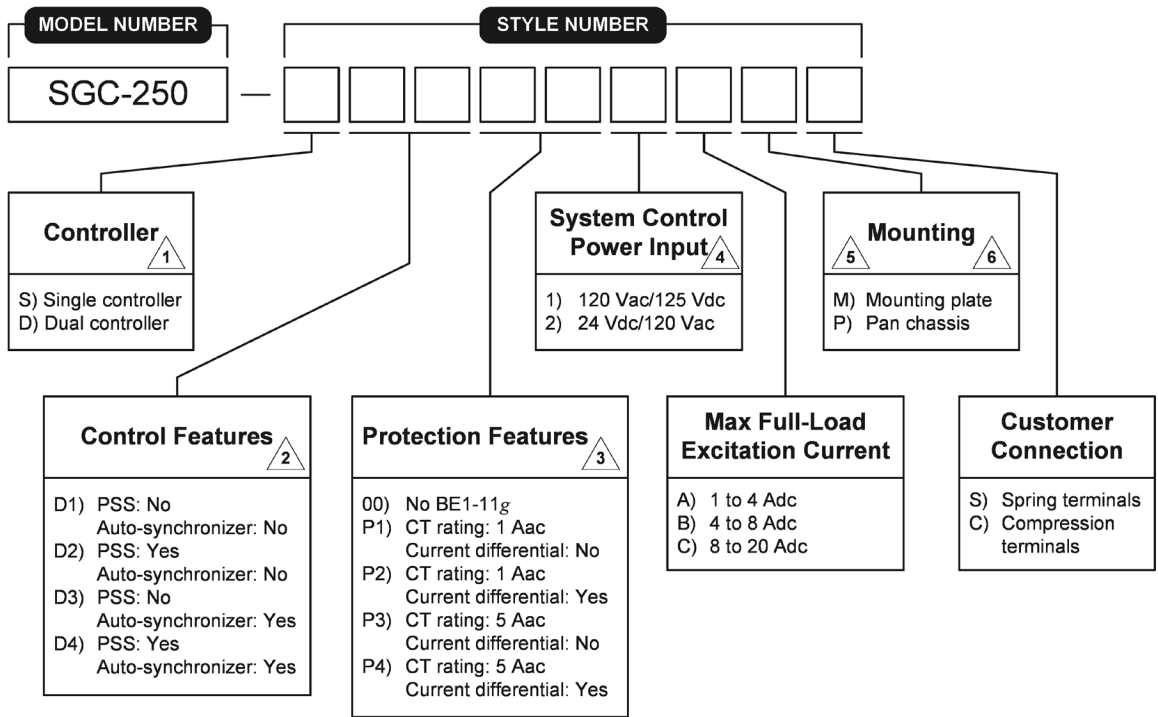

¹ Autotracking is determined by selection of a single or dual DECS-250 model.

² Control features:

Control Features	Power Supply	Power System Stabilizer ⁷	Autotracking	DECS-250 Terminals	Synchronizer	1 st Communication Protocol	2 nd Communication Protocol
D1	⁴	Not included	¹	Spring terminals	None	100Base-T (Modbus [®] TCP)	None
D2		PSS					
D3		Not included			Auto synchronizer		
D4		PSS					

P0099-74

³ Protection features:

Protection Features	Phase & Ground Current ⁸	Power Supply	RS-485 Protocol	Ethernet Protocol	Case	Alarm Contact	Option 1	Network Connection	Language	Option 2	Firmware
P1	1 Aac	⁴	Modbus [®]	Modbus [®] with BESTnet [™] Plus	Vertical case	Normally closed	None	Copper Ethernet	English	None	Latest Release
P2							Current Differential				
P3	5 Aac						None				
P4							Current Differential				

⁴ Power supply for DECS-250 is determined by option chosen in the SGC-250 style number.

⁵ The pan chassis consists of a rigid metal panel to hold the SGC-250 components. It is designed with additional structural supports to prevent it from bending or flexing. The mounting plate consists of a 1/16" thick sheet of galvanized steel to which the SGC-250 components are mounted. Typically, the mounting plate is installed in a specially-sized enclosure.

⁶ Pan chassis mounting option must be selected if dual controller and BE1-11g options are specified.

⁷ Coordinating agency guidelines (Western Electricity Coordinating Council (WECC) or other grid codes) may require "negative field forcing" included with the voltage regulator system where a power system stabilizer is required. Negative forcing improves the effective response at the generator output due to dynamic load changes, particularly for plants that have rotating exciters.

⁸ Protection features selections P2 and P4 provide current differential protection which equips the BE1-11g with dual phase and ground current sensing inputs.

Figure 1. SGC-250 Style Chart

Table 1. SGC-250 Dimensions and Weights

Style	Controller	BE1-11g	Mounting	Power Supply	Dimensions	Weight
Sxx001xMx	Single	No	Mounting plate	24 Vdc/120 Vac	37.4 x 21.7 x 8.7 in. 950 x 550 x 221 mm	50 lb. 22.7 kg
SxxP#1xMx	Single	Yes	Mounting plate	24 Vdc/120 Vac	37.4 x 29.5 x 10.4 in. 950 x 750 x 264 mm	100 lb. 45.4 kg
Sxx002xMx	Single	No	Mounting plate	125 Vdc/120 Vac	29.5 x 21.7 x 8.7 in. 750 x 550 x 221 mm	50 lb. 22.7 kg
SxxP#2xMx	Single	Yes	Mounting plate	125 Vdc/120 Vac	37.4 x 29.5 x 10.4 in. 950 x 750 x 264 mm	90 lb. 40.8 kg
Sxx001xPx	Single	No	Pan chassis	24 Vdc/120 Vac	37.4 x 21.7 x 9.6 in. 950 x 550 x 245 mm	85 lb. 38.6 kg
SxxP#2xPx	Single	Yes	Pan chassis	125 Vdc/120 Vac	37.4 x 29.5 x 11.9 in. 950 x 750 x 303 mm	135 lb. 61.2 kg
Sxx002xPx	Single	No	Pan chassis	125 Vdc/120 Vac	29.5 x 21.7 x 9.6 in. 750 x 550 x 245 mm	85 lb. 38.6 kg
SxxP#1xPx	Single	Yes	Pan chassis	24 Vdc/120 Vac	37.4 x 29.5 x 11.9 in. 950x 750 x 303 mm	135 lb. 61.2 kg
Dxx001xMx	Dual	No	Mounting plate	24 Vdc/120 Vac	37.4 x 29.5 x 8.7 in. 950 x 750 x 221 mm	100 lb. 45.4 kg
Dxx002Mx	Dual	No	Mounting plate	125 Vdc/120 Vac	37.4 x 29.5 x 8.7 in. 950 x 750 x 221 mm	90 lb. 40.8 kg
Dxx001xPx	Dual	No	Pan chassis	24 Vdc/120 Vac	37.4 x 29.5 x 10.1 in. 950 x 750 x 257 mm	135 lb. 61.2 kg
DxxP#2xPx	Dual	Yes	Pan chassis	125 Vdc/120 Vac	51.6 x 34.0 11.9 in. 1310 x 863 x 303 mm	135 lb. 61.2 kg
Dxx002xPx	Dual	No	Pan chassis	125 Vdc/120 Vac	37.4 x 29.5 x 10.1 in. 950 x 750 x 257 mm	135 lb. 61.2 kg
DxxP#1xPx	Dual	Yes	Pan chassis	24 Vdc/120 Vac	51.6 x 34.0 x 11.9 in. 1310 x 863 x 303 mm	135 lb. 61.2 kg