

Introduction

ES-55 Power Factor Relays protect synchronous motors from damage during increased loading or decreased excitation conditions. During these conditions, the motor can pull out of synchronization with its rotating field.

When the motor power factor decreases below the set value for the duration of the time delay, the ES 55 relay will trip. The trip region is illustrated in Figure 1.

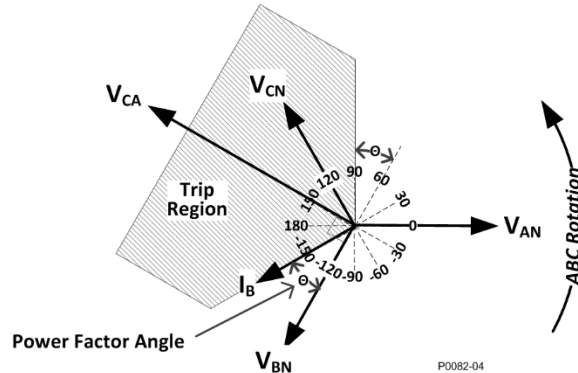

Figure 1. ES-55 Relay Trip Region

Microprocessor-based circuitry enhances functionality and improves performance. Internal diagnostics annunciate when relay function or accuracy is compromised.

Warning!

READ THIS MANUAL. Read this manual before installing or operating your ES series relay. Note all warnings, cautions, and notes in this manual as well as on the product. Failure to follow warning and cautionary labels may result in personal injury or property damage.

Exercise caution at all times.

It is the responsibility of the user to ensure that this product is installed, operated, and used for its intended function in the manner specified by this manual or any protection provided by this product may be impaired.

Voltage and Current Sensing

ES-55 relays operate on only the rms of the fundamental component of the sensed voltage and current, rejecting all harmonic components. The ES-55 relay is available with single-phase current sensing and single-phase voltage sensing.

Relay Adjustments

ES-55 relays are equipped with a PF (Lagging) adjustment and a Delay adjustment. The PF adjustment establishes the minimum acceptable power factor (PF) value. The Delay adjustment controls the amount of time between when the PF adjustment is exceeded and the ES-55 relay trips.

Publication	Revision	<h1 style="color: blue;">Instructions</h1>	Date	Page
9500100892	F		Jun 2025	1 of 8



Relay Output Contacts and Indicators

ES-55 relays come equipped with output contacts and LED indicators. Two form-C output contacts change state and the red Relay LED lights when the power factor is within the Trip Region as shown in Figure 1 for the duration of the set time delay. A continuously lit green Power LED indicates the presence of adequate sensing voltage. A flashing Power LED annunciates any relay fault detected by internal diagnostics.

Special Symbols

Special symbols are located on the ratings label on your ES series relay. These symbols are illustrated and described in Table 1.

Table 1. Special Symbol Descriptions

Symbol	Description
	Caution, Refer to Instructions
	Caution, Risk of Electric Shock

Specifications

Inputs

All units are self-powered.

Nominal Voltage: 120 Vac, 208 Vac, 240 Vac, 380 Vac, 415 Vac, or 480 Vac
(For other nominal voltages, contact Basler Electric.)
Voltage Input Operating Range: $\pm 25\%$ of nominal rating
Current Sensing: 1 Aac or 5 Aac nominal (see Style Chart)
Frequency: 50 or 60 Hz

Burden

Voltage Input: <2.5 VA
Current Input: <0.2 VA at nominal current

Overload Withstand

Voltage: 2 times nominal for 3 s
Current: 2 times nominal continuous
10 times nominal for 3 s

Setpoint

Range: Adjustable 0.45 to 0.95
Repeatability: $\pm 2^\circ$ of power factor angle (20 to 120% of nominal current)
Time Delay: Adjustable 0 to 10 s
Dropout (Reset): 3° of power factor angle

Outputs

Output contact trip performance is in accordance with IEEE Std C37.90™-2005 and IEC 60255-1

Contact Type: Two form-C contacts per protective function

Make and Carry for Tripping Duty

30 A, 250 Vdc for 0.2 seconds per IEEE Std C37.90-2005 - *IEEE Standard for Relays and Relay Systems Associated with Electric Power Apparatus*; 7 A continuous ac or dc

Break Resistive or Inductive

0.3 A at 125 or 250 Vdc (L/R = 0.04 maximum)

Environment

Operating Temperature: -40 to 70°C (-40 to 158°F)
Storage Temperature: -40 to 85°C (-40 to 185°F)

Publication 9500100892	Revision F	Instructions	Date Jun 2025	Page 2 of 8
----------------------------------	----------------------	---------------------	-------------------------	-----------------------

Temperature Coefficient:	0.02% per °C (200 ppm/°C)
Relative Humidity:	≤ 95%, non-condensing
Ingress Protection:	IP50 Case, IP20 Terminals
Pollution:	Degree 1
Insulation:	Class II
Overvoltage:	Category III

Physical

Terminals

Type:	Compression screw
Wire Size:	0.5-3.3 mm ² /20-12 AWG
Screw Torque:	4.4 to 5.3 in-lb (0.5 to 0.6 N•m)
Mounting (HxD):	DIN rail 1.38 x 0.29 inches (35 x 7.5 mm) complies with IEC 60715

Size (WxHxD)

All ES-55 models are supplied in a wide case.

Wide Case:	3.93 x 2.75 x 4.38 inches (100 x 70 x 111 mm)
------------	---

Weight

Wide Case:	1.10 lb (0.50 kg)
------------	-------------------

Applicable Standards

IEC

IEC 60255-1 Measuring relays and protection equipment – Part 1: *Common requirements (includes all referenced/normative IEC standards)*

IEEE

IEEE Std C37.90™-2005 – *IEEE Standard for Relays and Relay Systems Associated with Electric Power Apparatus*

IEEE Std C37.90.1™-2012 – *IEEE Standard for Surge Withstand Capability (SWC) Tests for Relays and Relay Systems Associated with Electric Power Apparatus*

IEEE Std C37.90.2™-2004 – *IEEE Standard for Withstand Capability of Relay Systems to Radiated Electromagnetic Interference from Transceivers*

IEEE Std C37.90.3™-2001 – *IEEE Standard for Electrostatic Discharge Tests for Protective Relays*

Agency Compliance

UL

This product is listed to applicable Canadian and US safety standards and requirements by UL.

- UL 508
- UL 94 V-0
- CSA C22.2 No. 0
- CSA C22.2 No. 14

CE and UKCA Compliance

This product has been evaluated and complies with the relevant essential requirements set forth by the EU legislation and UK Parliament.

EU directives:

- Low Voltage Directive (LVD) 2014/35/EU
- Electromagnetic Compatibility (EMC) 2014/30/EU
- Hazardous Substances (RoHS 2) 2011/65/EU

Harmonized standards used for evaluation:

- EN 50178
- EN 50581
- EN 60255-1

Publication	Revision	Instructions	Date	Page
9500100892	F		Jun 2025	3 of 8

- EN 60255-26
- EN 60255-27
- IEC 61000-6-4

FCC Requirements

This product complies with FCC 47 CFR Part 15.

China RoHS

The following table serves as the declaration of hazardous substances for China in accordance with PRC standard SJ/T 11364-2014. The EFUP (Environment Friendly Use Period) for this product is 40 years.

PRODUCT:	ES-55									
零件名称 Part Name	有害物质 Hazardous Substances									
	铅 Lead (Pb)	汞 Mercury (Hg)	镉 Cadmium (Cd)	六价铬 Hexavalent Chromium (Cr ⁶⁺)	多溴联苯 Polybrominated Biphenyls (PBB)	多溴二苯醚 Polybrominated Diphenyl Ethers (PBDE)	邻苯二甲酸二丁酯 Dibutyl Phthalate (DBP)	邻苯二甲酸丁苄酯 Benzyl butyl phthalate (BBP)	邻苯二甲酸二酯 Bis(2-ethylhexyl) phthalate (BEHP)	邻苯二甲酸二异丁酯 Diisobutyl phthalate (DIBP)
金属零件 Metal parts	O	O	O	O	O	O	O	O	O	O
聚合物 Polymers	O	O	O	O	O	O	O	O	O	O
电子产品 Electronics	X	O	O	O	O	O	O	O	O	O
电缆和互连配件 Cables & interconnect accessories	X	O	O	O	O	O	O	O	O	O
绝缘材料 Insulation material	O	O	O	O	O	O	O	O	O	O

本表格依据 SJ/T11364 的规定编制。

O: 表示该有害物质在该部件所有均质材料中的含量均在 GB/T 26572 规定的限量要求以下。

X: 表示该有害物质至少在该部件的某一均质材料中的含量超出 GB/T 26572 规定的限量要求。

This form was prepared according to the provisions of standard SJ/T11364.

O: Indicates that the hazardous substance content in all homogenous materials of this part is below the limit specified in standard GB/T 26252.

X: Indicates that the hazardous substance content in at least one of the homogenous materials of this part exceeds the limit specified in standard GB/T 26572.

Operation

Power factor and time delay settings on ES-55 relays are adjusted by controls marked PF and Delay.

PF Control

The PF control adjusts the power factor trip point. When the monitored power factor is less than the trip point by the setting established by the PF control for the duration of the time delay, a relay trip occurs. This condition energizes the relay output and lights the red Relay LED. The power factor trip point is adjustable from 0.45 to 0.95.

Delay Control

This control adjusts the amount of time that the power factor is within the Trip Region before a relay trip occurs. The delay is adjustable from 0 to 10 seconds.

Publication 9500100892	Revision F	<h1>Instructions</h1>	Date Jun 2025	Page 4 of 8
----------------------------------	----------------------	-----------------------	-------------------------	-----------------------

Setting Example

An ES-55 relay operates when the power factor is less than 0.80 (power factor angle greater than 37°).

- PF - 0.80
- Delay - 10 seconds

A trip occurs when the power factor becomes less than 0.80 for a period of 10 seconds. Dropout occurs when the power factor increases to 0.83 (power factor angle: $37^\circ - 3^\circ = 34^\circ$). The output relay de-energizes and the red Relay LED extinguishes.

Installation

ES relays should be installed in a dry location where the ambient temperature remains within the operating temperature range.

ES reverse power relays mount on standard DIN rails that comply with IEC 60715. Mounting involves hooking the top edge of the cutout on the base of the case over one edge of the DIN rail. The opposite side of the cutout containing the release clip is then pushed over the opposite side of the DIN rail. To remove or reposition the relay, pull the release clip downward and move the relay as required. Figure 2 shows the dimensions for the ES-55 relay.

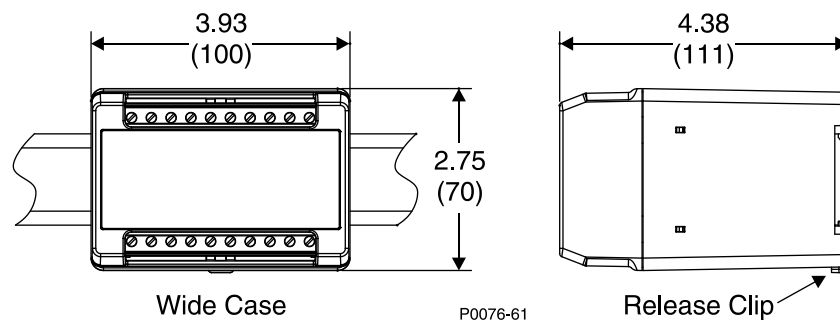

Figure 2. ES-55 Relay Dimensions

Relay connections should be made using wire that meets applicable codes and is properly sized for the application.

Warning!

When working on relay current inputs, CT circuits should first be shorted. An open CT secondary may contain high voltages when current is present on the CT primary.

Figure 3 shows the sensing connections for the ES-55 relay.

Caution

Before commissioning, check the equipment ratings, operating instructions, and installation instructions.

Note

When contact outputs are used to apply dc control voltage to inductive windings, such as relay coils, a flyback diode in parallel with the winding is recommended for EMI suppression. Failure to add such EMI suppression can result in circuit damage.

Publication 9500100892	Revision F	Instructions	Date Jun 2025	Page 5 of 8
----------------------------------	----------------------	---------------------	-------------------------	-----------------------

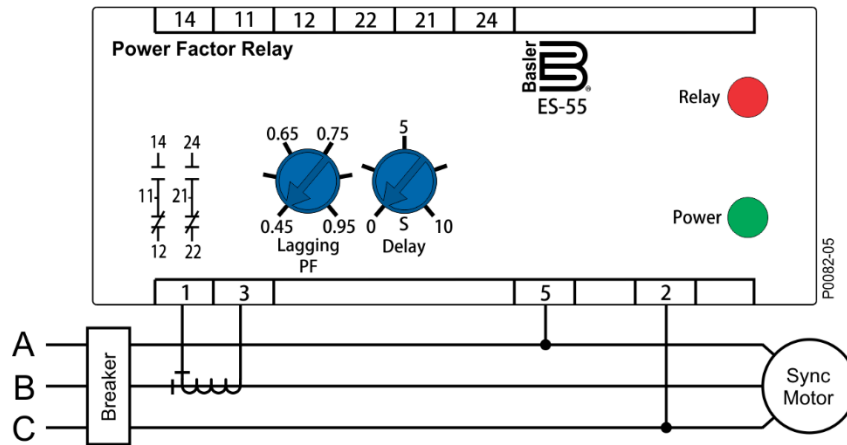

Figure 3. ES-55 Relay Sensing Connections

Calibration

The calibration marks on the faceplate are provided only as guides. Proper calibration requires using an accurate adjustable ac voltage and current power source in which both magnitude and angle can be adjusted. For establishing accurate settings, use the following procedure to calibrate your relay.

The ES-55 relay senses VCA and IB. Therefore, the power factor will be $PF = \cos(90 - \theta)$ where “ θ ” is the angle between the applied voltage and current input. Table 2 indicates the applied angle difference (θ) when using a single-phase source as described in this procedure.

Table 2. Applied Angle for Power Factor

Power Factor	Power Factor Angle (deg)	Applied Angle Difference (θ deg)
0.45	63.3	26.7
0.50	60.0	30.0
0.55	56.6	33.4
0.60	53.1	36.9
0.65	49.5	40.5
0.70	45.6	44.4
0.75	41.4	48.6
0.80	36.9	53.1
0.85	31.8	58.2
0.90	25.8	64.2
0.95	18.2	71.8

1. Adjust both the PF and Delay controls fully counterclockwise (CCW).
2. Apply nominal rated voltage and current with an angle difference for the desired PF per Table 2.
3. Adjust the PF control clockwise (CW) until the relay trips.
4. Increase the applied angle difference to 90° (PF=1.0) and set the Delay control to the desired time setting.
5. Step the applied angle difference to 0° (PF=0.0) and measure the time from when the angle is changed until the relay trips.
6. Compare the measured time to the desired time delay and adjust the Delay control accordingly.
7. Repeat Steps 4, 5, and 6 as required.

Publication 9500100892	Revision F	<h1>Instructions</h1>	Date Jun 2025	Page 6 of 8
----------------------------------	----------------------	-----------------------	-------------------------	-----------------------

Maintenance

ES-55 relays require no maintenance. In the event that your relay requires repair, contact Basler Electric, Highland, IL USA for return authorization.

Ordering Information

Figure 4 shows the ES-55 Power Factor Relay style numbers.

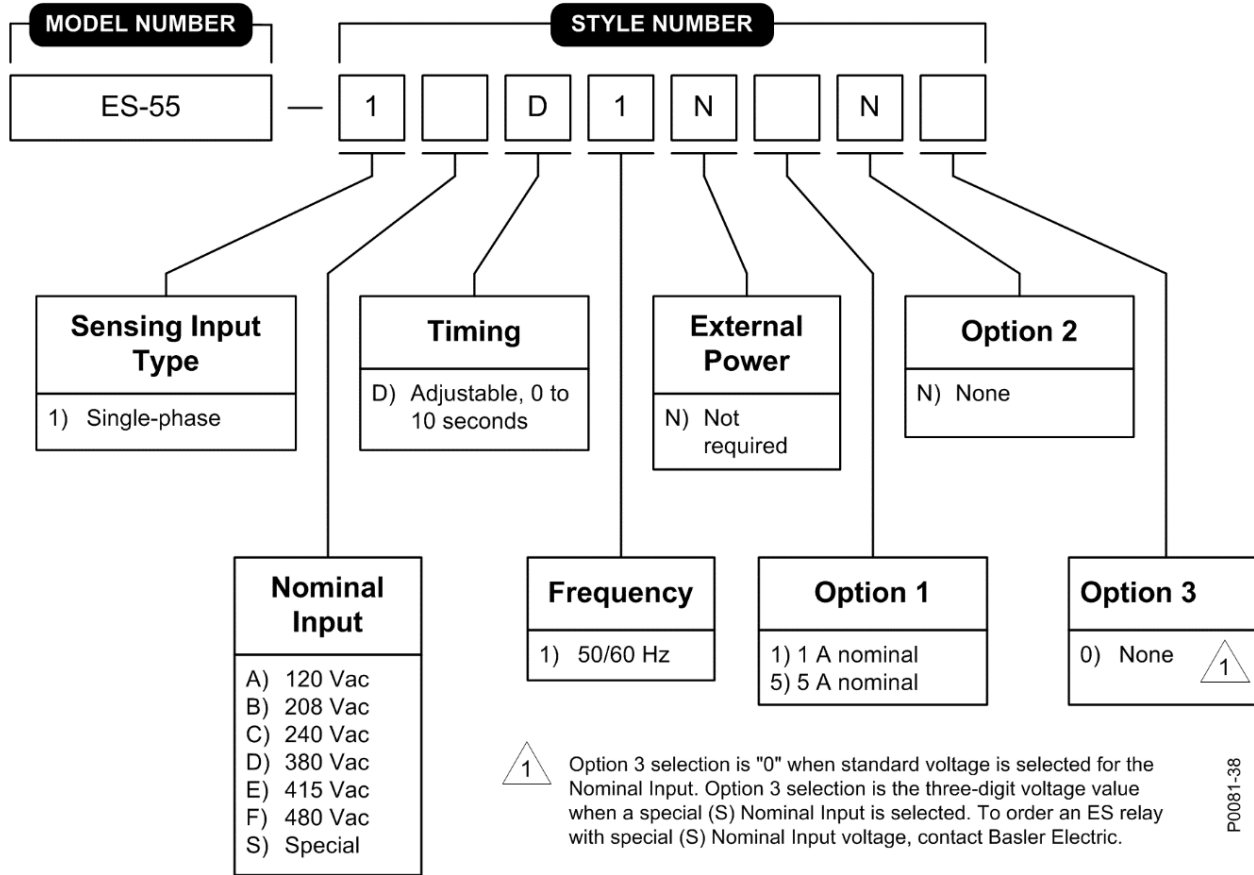

Figure 4. ES-55 Style Number Identification Chart

Mounting accessories (DIN rails and DIN rail end stops) are available from Basler Electric. Table 3 lists the part numbers for ordering.

Table 3. Mounting Accessories

Mounting Accessories	Basler Part Number
DIN Rail, 3.0 inches (76 mm) wide	9323900001
DIN Rail, 5.5 inches (140 mm) wide	9323900002
DIN Rail, 8.0 inches (203 mm) wide	9323900003
DIN Rail, 39.4 inches (1000 mm) wide	17366
DIN Rail End Stops	31761

This device utilizes redistributable software code copyrighted by Freescale Semiconductor, Inc. The following copyright notice and disclaimer are provided in this publication as required by the conditions for redistribution.

Copyright: 1997 - 2014 Freescale Semiconductor, Inc. All Rights Reserved.

Redistribution and use in source and binary forms, with or without modification, are permitted provided that the following conditions are met:

- Redistributions of source code must retain the above copyright notice, this list of conditions and the following disclaimer.
- Redistributions in binary form must reproduce the above copyright notice, this list of conditions and the following disclaimer in the documentation and/or other materials provided with the distribution.
- Neither the name of Freescale Semiconductor, Inc. nor the names of its contributors may be used to endorse or promote products derived from this software without specific prior written permission.

THIS SOFTWARE IS PROVIDED BY THE COPYRIGHT HOLDERS AND CONTRIBUTORS "AS IS" AND ANY EXPRESS OR IMPLIED WARRANTIES, INCLUDING, BUT NOT LIMITED TO, THE IMPLIED WARRANTIES OF MERCHANTABILITY AND FITNESS FOR A PARTICULAR PURPOSE ARE DISCLAIMED. IN NO EVENT SHALL THE COPYRIGHT HOLDER OR CONTRIBUTORS BE LIABLE FOR ANY DIRECT, INDIRECT, INCIDENTAL, SPECIAL, EXEMPLARY, OR CONSEQUENTIAL DAMAGES (INCLUDING, BUT NOT LIMITED TO, PROCUREMENT OF SUBSTITUTE GOODS OR SERVICES; LOSS OF USE, DATA, OR PROFITS; OR BUSINESS INTERRUPTION) HOWEVER CAUSED AND ON ANY THEORY OF LIABILITY, WHETHER IN CONTRACT, STRICT LIABILITY, OR TORT (INCLUDING NEGLIGENCE OR OTHERWISE) ARISING IN ANY WAY OUT OF THE USE OF THIS SOFTWARE, EVEN IF ADVISED OF THE POSSIBILITY OF SUCH DAMAGE.

Publication 9500100892	Revision F	<i>Instructions</i>	Date Jun 2025	Page 8 of 8
----------------------------------	----------------------	----------------------------	-------------------------	-----------------------