	www.basler.com +1 618.654.2341 (USA) info@basler.com	Model	ES-49
		Description	Temperature Relay

Introduction

ES-49 temperature relays use resistance detectors (RTDs) to monitor remote temperatures. An ES-49 relay can be specified with three or six inputs and specified to monitor copper or platinum RTDs. Microprocessor-based circuitry enhances functionality and improves performance. Internal diagnostics announce when relay function or accuracy is compromised.

Warning!
<p>READ THIS MANUAL. Read this manual before installing or operating your ES series relay. Note all warnings, cautions, and notes in this manual as well as on the product. Failure to follow warning and cautionary labels may result in personal injury or property damage. Exercise caution at all times.</p> <p>It is the responsibility of the user to ensure that this product is installed, operated, and used for its intended function in the manner specified by this manual or any protection provided by this product may be impaired.</p>

Three-Input Temperature Relays

Three temperature thresholds are provided through three trip point controls. Each trip point control triggers operation of a corresponding relay output whenever the temperature of any of the RTDs exceeds the threshold setting. An LED for each relay output lights to indicate an active output. A set of three LEDs indicate which of the three monitored RTDs has a temperature that exceeds any of the three trip points. A metering output provides a metering signal that is proportional to the temperature of the RTD with the highest temperature. A continuously lit Power LED indicates the presence of adequate relay control power. A flashing Power LED announces any relay fault detected by internal diagnostics.



Six-Input Temperature Relays

A single temperature threshold for the six RTD inputs is provided through a single trip point control. When the temperature of any one RTD exceeds the threshold setting, the relay output changes state and the Trip LED lights. A set of six LEDs indicate which of the six monitored RTDs has a temperature that exceeds the trip point. A continuously lit Power LED indicates the presence of adequate relay control power. A flashing Power LED announces any relay fault detected by internal diagnostics.

Special Symbols

Special symbols are located on the ratings label on your ES series relay. These symbols are illustrated and described in Table 1.

Table 1. Special Symbol Descriptions

Symbol	Description
	Caution, Refer to Instructions
	Caution, Risk of Electric Shock

Publication	Revision	<i>Instructions</i>	Date	Page
9500100999	J		Jun 2025	1 of 10

Specifications

Operating Power

All units require external operating power.

Nominal Voltage:	120 Vac, 240 Vac, or 24 Vdc
AC Operating Range:	Nominal $\pm 25\%$
DC Operating Range:	Nominal $\pm 20\%$
Frequency:	50 or 60 Hz

Burden

AC Power Supply:	<3 VA
DC Power Supply:	<2 W

RTD Inputs

The RTD inputs accommodate two- or three-wire RTDs. Depending on the style number of the relay, the RTD inputs accept either 10 Ω copper or 100 Ω platinum RTDs.

Style 5HA0x0N0:	3 inputs, 10 Ω copper RTDs
Style 5IA0x0N0:	3 inputs, 100 Ω platinum RTDs
Style 5JA0x0N0:	6 inputs, 10 Ω copper RTDs
Style 5KA0x0N0:	6 inputs, 100 Ω platinum RTDs

The temperature measurement range of each input is 0 to 200°C (32 to 392°F).

Metering Output

Range:	0 to 1 mAdc
Burden:	5 k Ω maximum

Setpoints

Range:	100 to 200°C (212 to 392°F)
Repeatability:	$\pm 2\%$ or $\pm 2^\circ\text{C}$ (whichever is greater)
Dropout (Reset):	Fixed at 2°C

Outputs

Output contact trip performance is in accordance with IEEE Std C37.90™-2005 and IEC 60255-1

Contact Type: Two form-C contacts per protective function

Make and Carry for Tripping Duty

30 A, 250 Vdc for 0.2 seconds per IEEE Std C37.90-2005 - *IEEE Standard for Relays and Relay Systems Associated with Electric Power Apparatus*; 7 A continuous ac or dc

Break Resistive or Inductive

0.3 A at 125 or 250 Vdc (L/R = 0.04 maximum)

Environment

Operating Temperature:	-40 to 70°C (-40 to 158°F)
Storage Temperature:	-40 to 85°C (-40 to 185°F)
Temperature Coefficient:	0.02% of nominal per °C (200 ppm/°C)
Relative Humidity:	$\leq 95\%$, non-condensing
Ingress Protection:	IP50 Case, IP20 Terminals
Pollution:	Degree 1
Insulation:	Class II
Overvoltage:	Category III

Physical

Terminals

Type:	Compression screw
Wire Size:	0.34-3.3 mm ² /22-12 AWG
Screw Torque:	4.4 to 5.3 in-lb (0.5 to 0.6 N•m)

Publication	Revision	Instructions	Date	Page
9500100999	J		Jun 2025	2 of 10

Mounting (HxD): DIN rail 1.38 x 0.29 inches (35 x 7.5 mm) complies with IEC 60715

Size (WxHxD)

All ES-49 models are supplied in a wide case.

Wide Case: 3.93 x 2.75 x 4.38 inches (100 x 70 x 111 mm)

Weight

Wide Case: 1.10 lb (0.50 kg)

Applicable Standards

IEC

IEC 60255-1 Measuring relays and protection equipment – Part 1: *Common requirements (includes all referenced/normative IEC standards)*

IEEE

IEEE Std C37.90™-2005 – *IEEE Standard for Relays and Relay Systems Associated with Electric Power Apparatus*

IEEE Std C37.90.1™-2012 – *IEEE Standard for Surge Withstand Capability (SWC) Tests for Relays and Relay Systems Associated with Electric Power Apparatus*

IEEE Std C37.90.2™-2004 – *IEEE Standard for Withstand Capability of Relay Systems to Radiated Electromagnetic Interference from Transceivers*

IEEE Std C37.90.3™-2001 – *IEEE Standard for Electrostatic Discharge Tests for Protective Relays*

Agency Compliance

UL

This product is listed to applicable Canadian and US safety standards and requirements by UL.

- UL 508
- UL 94 V-0
- CSA C22.2 No. 0
- CSA C22.2 No. 14

CE and UKCA Compliance

This product has been evaluated and complies with the relevant essential requirements set forth by the EU legislation and UK Parliament.

EU directives:

- Low Voltage Directive (LVD) 2014/35/EU
- Electromagnetic Compatibility (EMC) 2014/30/EU
- Hazardous Substances (RoHS 2) 2011/65/EU

Harmonized standards used for evaluation:

- EN 50178
- EN 50581
- EN 60255-1
- EN 60255-26
- EN 60255-27
- IEC 61000-6-4

FCC Requirements

This product complies with FCC 47 CFR Part 15.

China RoHS

The following table serves as the declaration of hazardous substances for China in accordance with PRC standard SJ/T 11364-2014. The EFUP (Environment Friendly Use Period) for this product is 40 years.

Publication 9500100999	Revision J	Instructions	Date Jun 2025	Page 3 of 10
----------------------------------	----------------------	---------------------	-------------------------	------------------------

PRODUCT:	ES-49									
零件名称 Part Name	有害物质 Hazardous Substances									
	铅 Lead (Pb)	汞 Mercury (Hg)	镉 Cadmium (Cd)	六价铬 Hexavalent Chromium (Cr ⁶⁺)	多溴联苯 Polybrominated Biphenyls (PBB)	多溴二苯醚 Polybrominated Diphenyl Ethers (PBDE)	邻苯二甲酸二丁酯 Dibutyl Phthalate (DBP)	邻苯二甲酸丁苄酯 Benzyl butyl phthalate (BBP)	邻苯二甲酸二酯 Bis(2-ethylhexyl) phthalate (BEHP)	邻苯二甲酸二异丁酯 Diisobutyl phthalate (DIBP)
金属零件 Metal parts	O	O	O	O	O	O	O	O	O	O
聚合物 Polymers	O	O	O	O	O	O	O	O	O	O
电子产品 Electronics	X	O	O	O	O	O	O	O	O	O
电缆和互连配件 Cables & interconnect accessories	X	O	O	O	O	O	O	O	O	O
绝缘材料 Insulation material	O	O	O	O	O	O	O	O	O	O

本表格依据 SJ/T11364 的规定编制。

O: 表示该有害物质在该部件所有均质材料中的含量均在 GB/T 26572 规定的限量要求以下。

X: 表示该有害物质至少在该部件的某一均质材料中的含量超出 GB/T 26572 规定的限量要求。

This form was prepared according to the provisions of standard SJ/T11364.

O: Indicates that the hazardous substance content in all homogenous materials of this part is below the limit specified in standard GB/T 26252.

X: Indicates that the hazardous substance content in at least one of the homogenous materials of this part exceeds the limit specified in standard GB/T 26572.

Operation

Three-Input Temperature Relays

ES-49 relays equipped with three inputs (styles 5HA0x0N0 or 5IA0x0N0) monitor three temperatures through RTDs connected at the front panel terminals. RTD connections are labeled A, B, and C. Temperature protection in ES-49 relays with three-inputs is adjusted by controls marked Set 1, Set 2, and Set 3.

Three-Input Set Controls

The ES-49 relay Set controls adjust the three temperature trip points. When the monitored temperature of any RTD rises above the setpoint established by a Set control, a relay trip occurs. This condition energizes the relay output associated with that Set control (1, 2, or 3), lights the red LED associated with that Set control (1, 2, or 3), and lights the red LEDs associated with all RTDs (A, B, or C) exceeding the trip point. Temperature trip points are adjustable from 100 to 200°C (212 to 392°F).

Dropout occurs when the monitored temperature of a picked up RTD input drops 2°C below the trip point. The red LED associated with that RTD (A, B, or C) is extinguished and, if no other RTDs are currently picked up, the red LED associated with that Set control (1, 2, or 3) is extinguished and the relay output associated with that Set control (1, 2, or 3) is de energized.

First Three-Input Setting Example

An ES-49 relay with three-inputs has the following settings:

- Set 1: 100°C (212°F)
- Set 2: 150°C (302°F)
- Set 3: 180°C (356°F)

Publication 9500100999	Revision J	Instructions	Date Jun 2025	Page 4 of 10
----------------------------------	----------------------	---------------------	-------------------------	------------------------

When the measured temperature of RTD A exceeds the Set 1 trip point, the red “A” LED lights to indicate that RTD A has exceeded a trip point, the red “1” LED lights to indicate that an RTD has exceeded the Set 1 trip point, and Relay 1 is energized.

In this scenario, it is evident that RTD A has exceeded the Set 1 trip point. Figure 1 illustrates the states of the front panel LEDs.

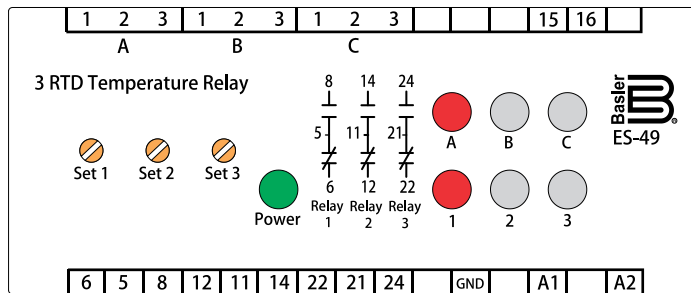

P0076-73

Figure 1. LED States in First Example

Second three-Input Setting Example

When the measured temperature of RTD A exceeds the Set 1 and Set 2 trip points, the red “A” LED lights to indicate that RTD A has exceeded a trip point, the red “1” LED lights and Relay 1 energizes to indicate that an RTD has exceeded the Set 1 trip point, and the red “2” LED lights and Relay 2 energizes to indicate that an RTD has exceeded the Set 2 trip point.

In this scenario, it is evident that RTD A has exceeded both Set 1 and 2 trip points. Figure 2 illustrates the states of the front panel LEDs.

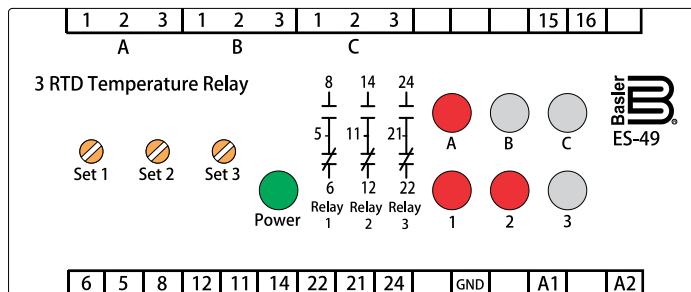

P0076-74

Figure 2. LED States in Second Example

Third Three-Input Setting Example

When the measured temperature of RTD A exceeds the Set 1 trip point and RTD B exceeds the Set 2 trip point, the red “A” and “B” LEDs light to indicate that both RTDs have exceeded a trip point, the red “1” and “2” LEDs light and Relays 1 and 2 energize to indicate that an RTD has exceeded the Set 1 and Set 2 trip points.

In this scenario, the RTD which has exceeded a particular trip point is not identifiable. It is only evident that at least one of the annunciated RTDs has exceeded the Set 2 trip point and that the other RTD has exceeded at least the Set 1 trip point. Figure 3 illustrates the states of the front panel LEDs.

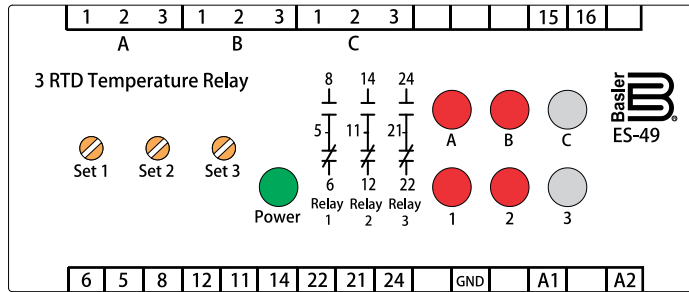

Figure 3. LED States in Third Example

Six-Input Temperature Relays

ES-49 relays equipped with six inputs (styles 5JA0x0N or 5KA0x0N) monitor six temperatures through RTDs connected at the front panel terminals. RTD connections are labeled A, B, C, D, E, and F. Temperature protection in ES-49 relays with six-inputs is adjusted by a control marked Set.

Six-Input Set Control

The ES-49 relay Set control adjusts the temperature trip point. When the monitored temperature of any RTD rises above the setpoint established by the Set control, a relay trip occurs. This condition energizes the relay output, lights the red Trip LED, and lights the red LEDs associated with all RTDs (A, B, C, D, E, or F) exceeding the trip point. The temperature trip point is adjustable from 100 to 200°C (212 to 392°F).

Dropout occurs when the monitored temperature of a picked up RTD input drops 2°C below the trip point. The red LED associated with that RTD (A, B, C, D, E, or F) is extinguished and, if no other RTDs are currently picked up, the red Trip LED is extinguished and the relay output is de-energized.

Six Input Setting Example

An ES-49 relay with six-inputs has the following setting:

- Set: 150°C (302°F)

In this example, RTD A and RTD E report temperatures greater than 150°C (302°C). When the measured temperatures of RTD A and RTD E exceed the Set trip point, the red “A” and “E” LEDs light to indicate that RTDs A and E have exceeded the trip point, the red “Trip” LED lights to indicate that an RTD has exceeded the Set trip point, and the relay is energized.

In this scenario, it is evident that RTD A and RTD E have both exceeded the trip point. Figure 4 illustrates the states of the front panel LEDs.

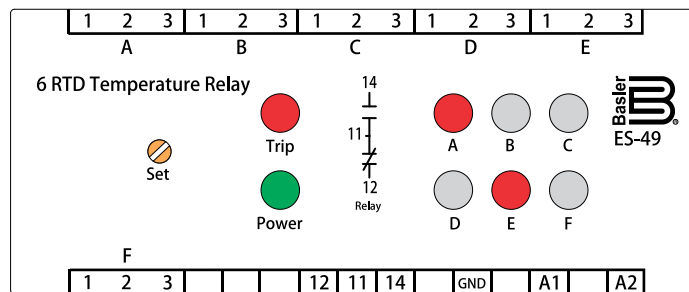

Figure 4. Six Input Setting Example LED States

Installation

ES relays should be installed in a dry location where the ambient temperature remains within the operating temperature range.

ES temperature relays mount on standard DIN rails that comply with IEC 60715. Mounting involves hooking the top edge of the cutout on the base of the case over one edge of the DIN rail. The opposite side of the cutout containing the release clip is then pushed over the opposite side of the DIN rail. To remove or reposition the relay, pull the release clip downward and move the relay as required. Figure 5 shows the dimensions of the ES-49 relays.

Publication 9500100999	Revision J	Instructions	Date Jun 2025	Page 6 of 10
----------------------------------	----------------------	---------------------	-------------------------	------------------------

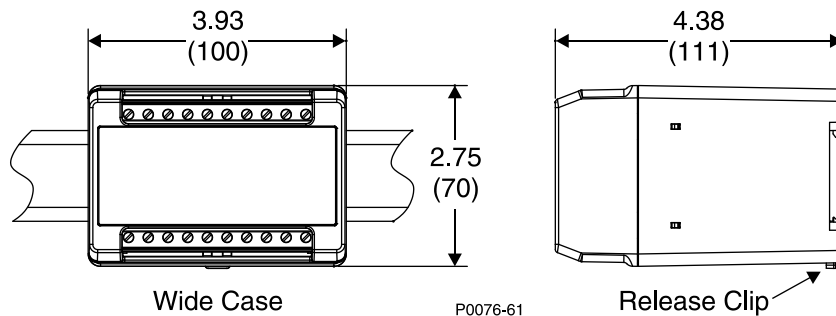

Figure 5. Relay Dimensions

Connections to the relay should be made using wire that meets applicable codes and is properly sized for the application. ES-49 relays accept RTD wire lengths up to 150 feet when using 22 AWG (0.34 mm²) wire. A jumper must be installed across all unused RTD inputs that are not connected to an RTD. Figure 6 illustrates the Three-Input ES 49 and Six-Input ES-49 controls, indicators, and terminal connections.

Caution

Verify the integrity of any protective conductor connections before carrying out any other actions.

Before commissioning, check the equipment ratings, operating instructions, and installation instructions.

Notes

Ensure that the ES-49 relay GND terminal is properly wired to a suitable earth ground.

When contact outputs are used to apply dc control voltage to inductive windings, such as relay coils, a flyback diode in parallel with the winding is recommended for EMI suppression. Failure to add such EMI suppression can result in circuit damage.

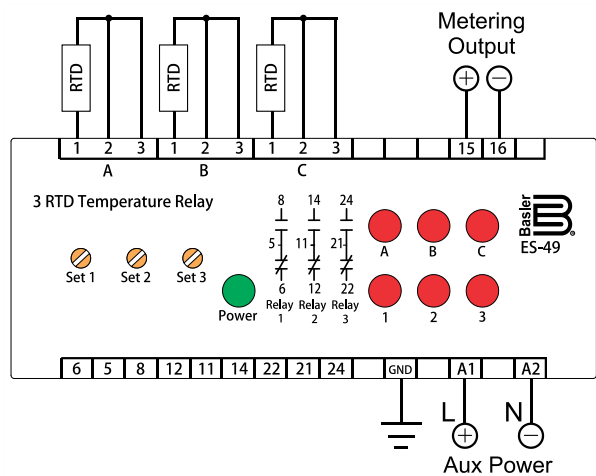

Three-Input ES-49 Relay

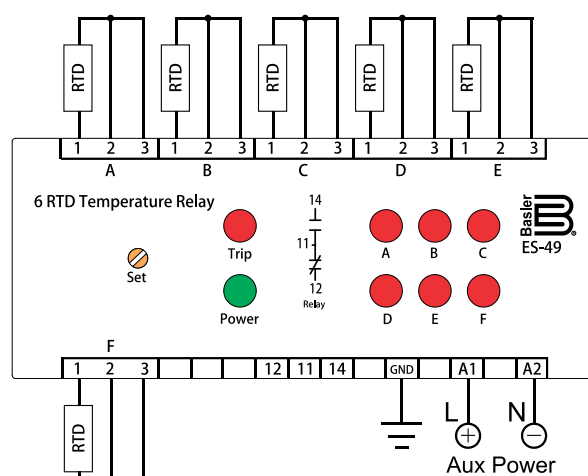

Six-Input ES-49 Relay

Figure 6. Three-Input and Six Input ES-49 Relay Connections

Publication 9500100999	Revision J	Instructions	Date Jun 2025	Page 7 of 10
----------------------------------	----------------------	---------------------	-------------------------	------------------------

Calibration

Calibration requires the use of a variable resistance to simulate an RTD. While calibrating the relay, jumpers must be connected across the remaining, open RTD inputs. A temperature and resistance cross-reference table for your RTDs is also needed. To calibrate a three-input ES-49 relay (styles 5HA0x0N0 or 5IA0x0N0), use the *Three-Input Relay Calibration Procedure*. To calibrate a six-input ES-49 relay (styles 5JA0x0N0 or 5KA0x0N0), use the *Six-Input Relay Calibration Procedure*.

Three-Input Relay Calibration Procedure

For clarity and ease of calibration, this procedure assigns the highest trip point to Set 3, the next highest trip point to Set 2, and the lowest trip point to Set 1. However, any trip point can be assigned to any set control if desired.

1. Adjust the Set 1, 2, and 3 controls fully clockwise (CW).
2. Connect the variable resistance to RTD input A and adjust it to 10 Ω (style 5HA0x0N0) or 100 Ω (style 5IA0x0N0). Install jumpers across the remaining RTD inputs.
3. Apply nominal external operating power to the relay.
4. Set the variable resistance to the value that corresponds to the highest desired temperature trip point between 100 and 200°C (212 to 392°F).
5. Adjust the Set 3 control counterclockwise (CCW) until the “A” and “3” LEDs light and output relay 3 energizes.
6. Set the variable resistance to the value that corresponds to the next highest desired temperature trip point between 100 and 200°C (212 to 392°F).
7. Adjust the Set 2 control counterclockwise (CCW) until the “A” and “2” LEDs light and output relay 2 energizes.
8. Set the variable resistance to the value that corresponds to the lowest desired temperature trip point between 100 and 200°C (212 to 392°F).
9. Adjust the Set 1 control counterclockwise (CCW) until the “A” and “1” LEDs light and output relay 1 energizes.

Six-Input Relay Calibration Procedure

1. Adjust the Set control fully CW.
2. Connect the variable resistance to RTD input A and adjust it to 10 Ω (style 5JA0x0N0) or 100 Ω (style 5KA0x0N0). Install jumpers across the remaining RTD inputs.
3. Apply nominal external operating power to the relay.
4. Set the variable resistance to the value that corresponds to the desired temperature trip point between 100 and 200°C (212 to 392°F).
5. Adjust the Set control CCW until the “A” and “Trip” LEDs light and the output relay energizes.

Maintenance

ES relays require no maintenance. In the event that your relay requires repair, contact Basler Electric, Highland, IL, USA for return authorization.

Publication 9500100999	Revision J	Instructions	Date Jun 2025	Page 8 of 10
----------------------------------	----------------------	---------------------	-------------------------	------------------------

Ordering Information

Mounting accessories (DIN rails and DIN rail end stops) are available from Basler Electric. Table 2 lists the part numbers for ordering.

Figure 7 shows the ES-49 temperature relay style chart.

Table 2. Mounting Accessories

Mounting Accessories	Basler Part Number
DIN Rail, 3.0 inches (76 mm) wide	9323900001
DIN Rail, 5.5 inches (140 mm) wide	9323900002
DIN Rail, 8.0 inches (203 mm) wide	9323900003
DIN Rail, 39.4 inches (1,000 mm) wide	17366
DIN Rail End Stops	31761

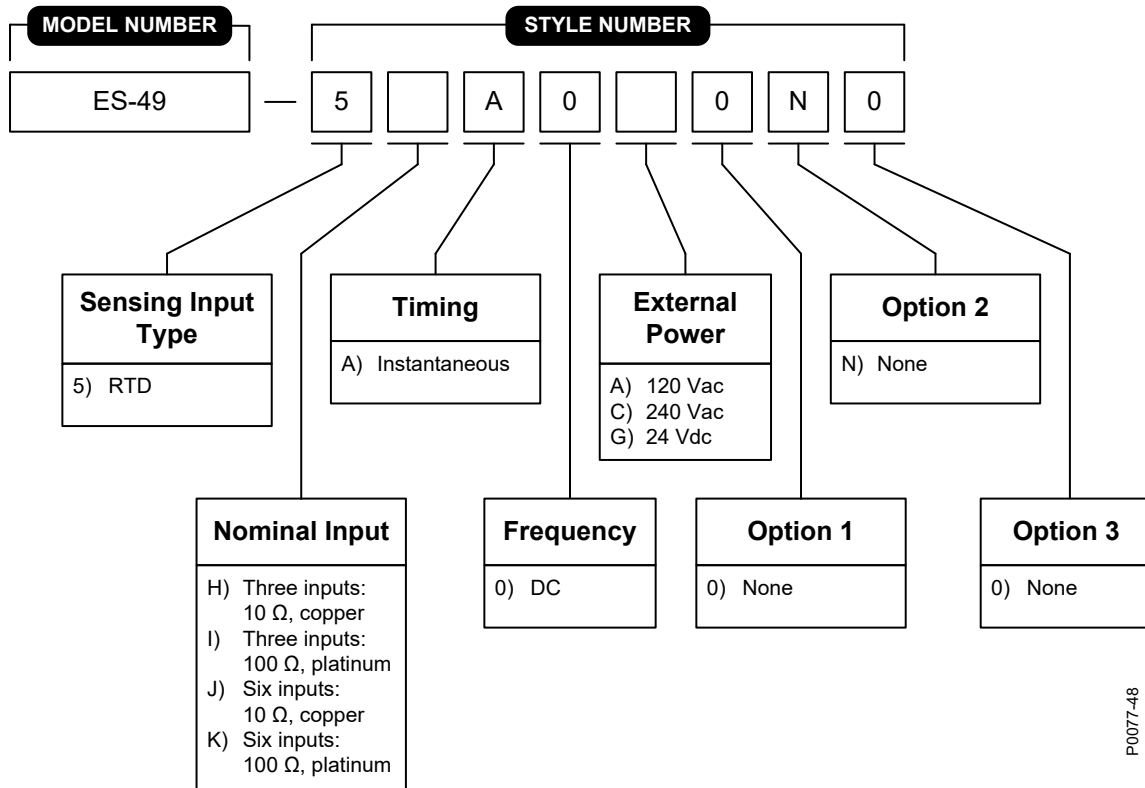

Figure 7. ES-49 Style Number Identification Chart

This device utilizes redistributable software code copyrighted by Freescale Semiconductor, Inc. The following copyright notice and disclaimer are provided in this publication as required by the conditions for redistribution.

Copyright: 1997 - 2014 Freescale Semiconductor, Inc. All Rights Reserved.

Redistribution and use in source and binary forms, with or without modification, are permitted provided that the following conditions are met:

- Redistributions of source code must retain the above copyright notice, this list of conditions and the following disclaimer.
- Redistributions in binary form must reproduce the above copyright notice, this list of conditions and the following disclaimer in the documentation and/or other materials provided with the distribution.
- Neither the name of Freescale Semiconductor, Inc. nor the names of its contributors may be used to endorse or promote products derived from this software without specific prior written permission.

THIS SOFTWARE IS PROVIDED BY THE COPYRIGHT HOLDERS AND CONTRIBUTORS "AS IS" AND ANY EXPRESS OR IMPLIED WARRANTIES, INCLUDING, BUT NOT LIMITED TO, THE IMPLIED WARRANTIES OF MERCHANTABILITY AND FITNESS FOR A PARTICULAR PURPOSE ARE DISCLAIMED. IN NO EVENT SHALL THE COPYRIGHT HOLDER OR CONTRIBUTORS BE LIABLE FOR ANY DIRECT, INDIRECT, INCIDENTAL, SPECIAL, EXEMPLARY, OR CONSEQUENTIAL DAMAGES (INCLUDING, BUT NOT LIMITED TO, PROCUREMENT OF SUBSTITUTE GOODS OR SERVICES; LOSS OF USE, DATA, OR PROFITS; OR BUSINESS INTERRUPTION) HOWEVER CAUSED AND ON ANY THEORY OF LIABILITY, WHETHER IN CONTRACT, STRICT LIABILITY, OR TORT (INCLUDING NEGLIGENCE OR OTHERWISE) ARISING IN ANY WAY OUT OF THE USE OF THIS SOFTWARE, EVEN IF ADVISED OF THE POSSIBILITY OF SUCH DAMAGE.

Publication 9500100999	Revision J	<i>Instructions</i>	Date Jun 2025	Page 10 of 10
----------------------------------	----------------------	----------------------------	-------------------------	-------------------------