

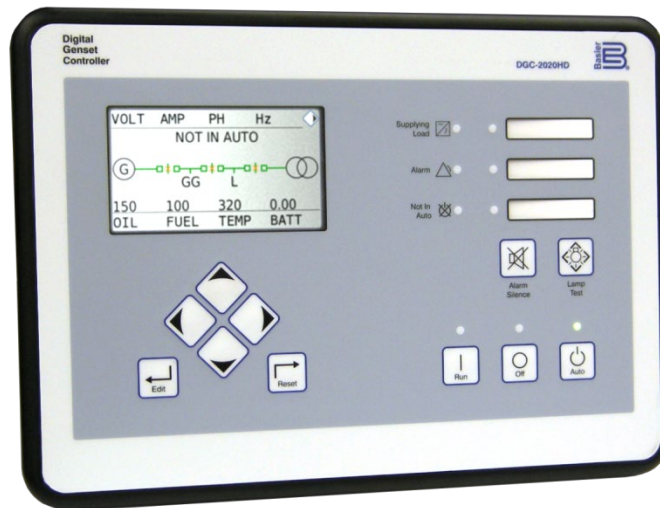



DGC-2020HD

Digital Genset Controller

Quick Start Instruction Manual



 **WARNING:** California's Proposition 65 requires special warnings for products that may contain chemicals known to the state of California to cause cancer, birth defects, or other reproductive harm. Please note that by posting this Proposition 65 warning, we are notifying you that one or more of the Proposition 65 listed chemicals may be present in products we sell to you. For more information about the specific chemicals found in this product, please visit <https://www.basler.com/Prop65>.

Preface

This instruction manual provides basic installation and setup information for the DGC-2020HD Digital Genset Controller. To accomplish this, the following information is provided:

- Mounting
- Terminals and connectors
- Typical applications
- BESTCOMSP^{Plus}® software
- Configuration
- BESTlogic™ *Plus*
- Controls and indicators

Conventions Used in this Manual

Important safety and procedural information is emphasized and presented in this manual through Warning, Caution, and Note boxes. Each type is illustrated and defined as follows.

Warning!

Warning boxes call attention to conditions or actions that may cause personal injury or death.

Caution

Caution boxes call attention to operating conditions that may lead to equipment or property damage.

Note

Note boxes emphasize important information pertaining to Digital Genset Controller installation or operation.

DGC-2020HD Instruction Manual Catalog

Available instruction manuals for the DGC-2020HD are listed in Table 1.

Table 1. Instruction Manuals

Part Number	Description
9469300993	Quick Start (this manual)
9469300994	Installation
9469300995	Configuration
9469300996	Operation
9469300997	Accessories
9469300998	Modbus® Protocol



12570 State Route 143
Highland IL 62249-1074 USA

www.basler.com

info@basler.com

Tel: +1 618.654.2341

Fax: +1 618.654.2351

© 2023 by Basler Electric

All rights reserved

First printing: October 2016

Warning!

READ THIS MANUAL. Read this manual before installing, operating, or maintaining the DGC-2020HD. Note all warnings, cautions, and notes in this manual as well as on the product. Keep this manual with the product for reference. Only qualified personnel should install, operate, or service this system. Failure to follow warning and cautionary labels may result in personal injury or property damage. Exercise caution at all times.

Caution

Installing previous versions of firmware may result in compatibility issues causing the inability to operate properly and may not have the enhancements and resolutions to issues that more recent versions provide. Basler Electric highly recommends using the latest version of firmware at all times. Using previous versions of firmware is at the user's risk and may void the warranty of the unit.

Basler Electric does not assume any responsibility to compliance or noncompliance with national code, local code, or any other applicable code. This manual serves as reference material that must be well understood prior to installation, operation, or maintenance.

For terms of service relating to this product and software, see the *Commercial Terms of Products and Services* document available at www.basler.com/terms.

This publication contains confidential information of Basler Electric Company, an Illinois corporation. It is loaned for confidential use, subject to return on request, and with the mutual understanding that it will not be used in any manner detrimental to the interests of Basler Electric Company and used strictly for the purpose intended.

It is not the intention of this manual to cover all details and variations in equipment, nor does this manual provide data for every possible contingency regarding installation or operation. The availability and design of all features and options are subject to modification without notice. Over time, improvements and revisions may be made to this publication. Before performing any of the following procedures, contact Basler Electric for the latest revision of this manual.

The English-language version of this manual serves as the only approved manual version.

This product contains, in part, open source software (software licensed in a way that ensures freedom to run, copy, distribute, study, change, and improve the software) and you are granted a license to that software under the terms of either the GNU General Public License or GNU Lesser General Public License. The licenses, at the time of sale of the product, allow you to freely copy, modify, and redistribute that software and no other statement or documentation from us, including our End User License Agreement, places any additional restrictions on what you may do with that software.

For at least three (3) years from the date of distribution of this product, a machine-readable copy of the complete corresponding source code for the version of the programs distributed to you will be sent upon request (contact information is provided above). A fee of no more than our cost of physically performing the source code distribution is charged.

The source code is distributed in the hope that it will be useful, but WITHOUT ANY REPRESENTATION or WARRANTY or even the implied warranty of MERCHANTABILITY or FITNESS FOR A PARTICULAR PURPOSE. Refer to the source code distribution for additional restrictions regarding warranty and copyrights.

For a complete copy of GNU GENERAL PUBLIC LICENSE Version 2, June 1991 or GNU LESSER GENERAL PUBLIC LICENSE Version 2.1, February 1999 refer to www.gnu.org or contact Basler Electric. You, as a Basler Electric Company customer, agree to abide by the terms and conditions of GNU GENERAL PUBLIC LICENSE Version 2, June 1991 or GNU LESSER GENERAL PUBLIC LICENSE Version 2.1, February 1999, and as such hold Basler Electric Company harmless related to any open source software incorporated in this product. Basler Electric Company disclaims any and all liability associated with the open source software and the user agrees to defend and indemnify Basler Electric Company, its directors, officers, and employees from and against any and all losses, claims, attorneys' fees, and expenses arising from the use, sharing, or redistribution of the software. Review the software website for the latest version of the software documentation.

Portions of this software are copyright © 2014 The FreeType Project (www.freetype.org). All rights reserved.

The following statement applies only to the fontconfig library:

fontconfig/COPYING

Copyright © 2000,2001,2002,2003,2004,2006,2007 Keith Packard

Copyright © 2005 Patrick Lam

Copyright © 2009 Roozbeh Pournader

Copyright © 2008,2009 Red Hat, Inc.

Copyright © 2008 Danilo Šegan

Copyright © 2012 Google, Inc.

Permission to use, copy, modify, distribute, and sell this software and its documentation for any purpose is hereby granted without fee, provided that the above copyright notice appear in all copies and that both that copyright notice and this permission notice appear in supporting documentation, and that the name of the author(s) not be used in advertising or publicity pertaining to distribution of the software without specific, written prior permission. The authors make no representations about the suitability of this software for any purpose. It is provided "as is" without express or implied warranty.

THE AUTHOR(S) DISCLAIMS ALL WARRANTIES WITH REGARD TO THIS SOFTWARE, INCLUDING ALL IMPLIED WARRANTIES OF MERCHANTABILITY AND FITNESS, IN NO EVENT SHALL THE AUTHOR(S) BE LIABLE FOR ANY SPECIAL, INDIRECT OR CONSEQUENTIAL DAMAGES OR ANY DAMAGES WHATSOEVER RESULTING FROM LOSS OF USE, DATA OR PROFITS, WHETHER IN AN ACTION OF CONTRACT, NEGLIGENCE OR OTHER TORTIOUS ACTION, ARISING OUT OF OR IN CONNECTION WITH THE USE OR PERFORMANCE OF THIS SOFTWARE.



Revision History

A historical summary of the changes made to this instruction manual is provided below. Revisions are listed in reverse chronological order.

Visit www.basler.com to download the latest hardware, firmware, and BESTCOMS*Plus*® revision histories.

Instruction Manual Revision History

Manual Revision and Date	Change
D, October 2023	<ul style="list-style-type: none"> Added support for firmware version 3.08.00 and BESTCOMS<i>Plus</i> version 5.05.01 Removed BESTCOMS<i>Plus</i> activation requirements and updated installation procedure Minor text edits
C, August 2021	<ul style="list-style-type: none"> Added "Installing previous firmware versions" caution box to Preface
B, October 2019	<ul style="list-style-type: none"> Removed Rev Letter from all pages Changed sequential numbering to sectional numbering Moved Instruction Manual Revision History into Preface Removed standalone Revision History chapter
A2, April 2019	<ul style="list-style-type: none"> Updated Proposition 65 statement
A1, October 2018	<ul style="list-style-type: none"> Added Proposition 65 statement
A, July 2018	<ul style="list-style-type: none"> Added new mounting options
—, October 2016	<ul style="list-style-type: none"> Initial release



Contents

Introduction.....	1-1
Mounting.....	2-1
Terminals and Connectors.....	3-1
Typical Applications	4-1
BESTCOMSP <i>Plus</i> ® Software	5-1
Configuration.....	6-1
BESTlogic™ <i>Plus</i>	7-1
Controls and Indicators	8-1



1 • Introduction

This manual provides basic installation and setup information for the DGC-2020HD Digital Genset Controller. For complete information, refer to the appropriate DGC-2020HD instruction manual.

Caution

This Quick Start manual is intended for use by qualified personnel only.

Default Settings

Each DGC-2020HD is delivered with default settings that are based on average values and may not be appropriate for your application. All settings must be properly configured for your application before running the engine-generator set.

Warning!

Do not place the DGC-2020HD controller into service until all settings have been properly configured.

Features and Functions

The DGC-2020HD provides integrated engine-genset control, protection, and metering in a single package. Microprocessor-based technology allows for exact measurement, setpoint adjustment, and timing functions. Front panel controls and indicators enable quick and simple DGC-2020HD operation. A backlit liquid crystal display (LCD) can be viewed under a wide range of ambient light and temperature conditions. Basler Electric communication software (BESTCOMSP^{Plus}®) allows units to be easily customized for each application. Because of the low sensing burden in the DGC-2020HD, dedicated potential transformers (PTs) are not required.

The DGC-2020HD Digital Genset Controller has the following features:

- Local and remote generator control
- Engine, generator, loss of mains (optional), and differential protection (optional)
- Automatic transfer switch control (mains failure)
- Automatic generator configuration detection
- Generator sequencing
- Generator soft loading/unloading
- Auto synchronizing (optional)
- Programmable analog engine senders
- 16 programmable contact inputs
- Three programmable front panel LEDs, with labels
- Color Touch-Screen Display (optional)
- Up to four local analog inputs
- Demand start/stop and generator sequencing
- KW and kvar load control
- KW and kvar load sharing via Ethernet or analog load share lines
- Programmable logic
- Exercise timer
- ECU communications via SAE J1939
- Marathon DVR2000E+ voltage regulator control via SAE J1939
- Integrated USB, RS485, and Ethernet communication
- Two J1939 CAN Bus ports

- Additional modules available to expand the capabilities of the DGC-2020HD
- Mains power control modes include peak shaving, base loading, and import/export
- Automatic load shedding
- Load Anticipation Function (optional)
- Generator, Group, Mains, and Tie Breaker Control
- Generator group starting
- Complex power system control
- DIN Rail or Rear Panel mounting (optional)

An overview of DGC-2020HD Digital Genset Controller functions is provided in the following paragraphs.

Generator and Bus Protection and Metering

Multifunction protection guards against overvoltage, undervoltage, excessive forward and reverse power, underfrequency, and overfrequency. Overcurrent, phase imbalance, loss of mains, frequency rate-of-change, phase differential, and neutral differential protection are available as options. Each protection function has an adjustable pickup and time delay setting. Sixteen inverse time curves, in addition to user-programmable curves, enable the DGC-2020HD to offer overcurrent protection in a variety of applications. Each protective element can be assigned to protect the generator, bus 1, or bus 2 sensing inputs with settings groups.

Metered generator and bus parameters include voltage, current, frequency, vector shift, real power (watts), apparent power (VA), and power factor (PF).

Engine Protection and Metering

Engine protection features include oil pressure and coolant temperature monitoring, overcrank protection, ECU-specific protection elements, and diagnostic reporting.

Metered engine parameters include oil pressure, coolant temperature, battery voltage, speed, fuel level, engine load, coolant level (from ECU), ECU-specific parameters, and run-time statistics.

Load Sharing

The DGC-2020HD provides analog outputs to the power system in the form of analog bias signals to the voltage regulator and speed governor. A pulse width modulated (PWM) speed bias output is also available. When the generator breaker is closed and load sharing is enabled, the DGC-2020HD shares the real power load proportionally with other generators in the system. Load sharing can be implemented on the Analog Load Share Line or through Ethernet communications. Reactive power (kvar) sharing is accomplished through Ethernet communications.

Event Recording

A history of system events are logged in nonvolatile memory. The DGC-2020HD retains records for 128 unique types of events. Each record tracks the number of times that an event has occurred and records a time stamp of the first and last occurrences.

A Sequence of Events (SER) log is also available. This log tracks the internal and external status of the DGC-2020HD. Events are scanned at five millisecond intervals with 1,023 events stored per record. All changes of state that occur during each scan are time- and date-stamped. Sequences of Events reports are available through BESTCOMSP^{Plus}. Over 1,000 records can be retained in nonvolatile memory. When the SER memory becomes full, the oldest record is replaced by the latest one acquired.

Data Logging

The data logging function of the DGC-2020HD records up to six records of user-selectable, real-time parameter data. For more information, see the *Reporting and Alarms* chapter in the *Operation* manual.

Contact Inputs and Outputs

DGC-2020HD controllers have 16 programmable contact inputs. All contact inputs recognize dry contacts. The programmable inputs can be configured to initiate a pre-alarm or alarm condition. A

programmable input can be programmed to receive a contact input from an automatic transfer switch (ATS). In addition, a programmable Battle Override function allows overriding of DGC-2020HD alarms and protection functions. Each programmable input can be assigned a user-defined name for easy identification at the front panel display and in fault records.

Output contacts include three dedicated relays for energizing an engine's glow plugs, fuel solenoid, and starter solenoid. An additional twelve programmable output contacts are provided.

Additional contact inputs and output contacts can be accommodated with an optional CEM-2020 Contact Expansion Module. Contact Basler Electric for ordering information.

Automatic Transfer Switch Control (Mains Failure)

The DGC-2020HD has the ability to detect a mains failure via a single- or three-phase bus input. A mains failure is established when any one of the following conditions are met:

- Any phase of bus voltage falls below the dead bus threshold
- Any phase of bus voltage is unstable due to overvoltage or undervoltage
- Any phase of bus voltage is unstable due to overfrequency or underfrequency

At this time, the DGC-2020HD starts enough generators to pick up the anticipated load and transfers the load to the generators when predetermined conditions are met. The DGC-2020HD implements open or closed breaker transitions to and from the mains. When the mains returns and is considered stable, the DGC-2020HD transfers the load back to the mains and stops the engines. During closed breaker transitions, the optional Auto Synchronizer synchronizes the generators to the mains before transferring the load from generator power to utility power.

Device Security

Passwords provide access security for six distinct functional access areas: Read, Control, Operator, Settings, Design, and Administrator. Each username/password is assigned an access area with access to that area and each area below it. An administrator password provides access to all six of the functional areas.

A second dimension of security is provided by the ability to restrict access for any of the access areas to only specific communication ports. For example, you could set up security to deny access to control commands through an Ethernet port.

Security settings affect read and write access. Refer to the *Security* chapter in the *Configuration* manual for more information.

Communication

DGC-2020HD communication features include a mini-B USB port, RS-485 port, two copper Ethernet ports or one fiber optic Ethernet port (optional), and SAE J1939 interface.

USB Port

The USB communication port can be used with BESTCOMSP^{Plus}® software to quickly configure a DGC-2020HD with the desired settings or retrieve metering values and event log records.

RS485 Port

An RS485 communication port uses the Modbus™ communication protocol and enables remote control and monitoring of the DGC-2020HD over a polled network. RS485 Modbus supports a single Modbus Master only.

Ethernet Port(s)

Depending on style number, each DGC-2020HD is equipped with either dual copper (100Base-T) Ethernet communication ports (style xxxxDxxxx) or a fiber optic (100Base-FX) Ethernet communication port (style xxxxFxxxx).

Ethernet ports provide communications between the DGC-2020HD and a PC via BESTCOMSP^{Plus} or other DGC-2020HDs in a network. An Ethernet connection to a PC running BESTCOMSP^{Plus} provides

remote metering, setting, annunciation, and control of the DGC-2020HD. Ethernet communication between DGC-2020HDs allows for generator sequencing on an islanded system.

CAN Interface

The CAN (Control Area Network) interface provides high-speed communication between the DGC-2020HD and the engine control unit (ECU) on an electronically controlled engine. This interface provides access to oil pressure, coolant temperature, and engine speed data by reading these parameters directly from the ECU. When available, engine diagnostic data can also be accessed. The CAN interface supports the following protocols:

- SAE J1939 Protocol - Oil pressure, coolant temperature, and engine speed data are received from the ECU. In addition, DTCs (Diagnostic Trouble Codes) help diagnose any engine-related failures. The engine DTCs are displayed on the front panel of the DGC-2020HD and may be obtained using BESTCOMSPPlus® software.
- mtu Protocol - A DGC-2020HD connected to a genset equipped with an mtu engine ECU receives Oil pressure, coolant temperature, and engine speed data from the engine controller, along with various alarms and pre-alarms that are mtu-specific. In addition, the DGC-2020HD tracks and displays the active fault codes issued by the mtu engine ECU.

Style Number

Standard-order DGC-2020HD controllers are identified by a style number which consists of a combination of letters and numbers that define the controller’s electrical characteristics and operational features. The model number, together with the style number, describes the options included in a specific controller. Figure 1-1 illustrates the DGC-2020HD style number identification chart.

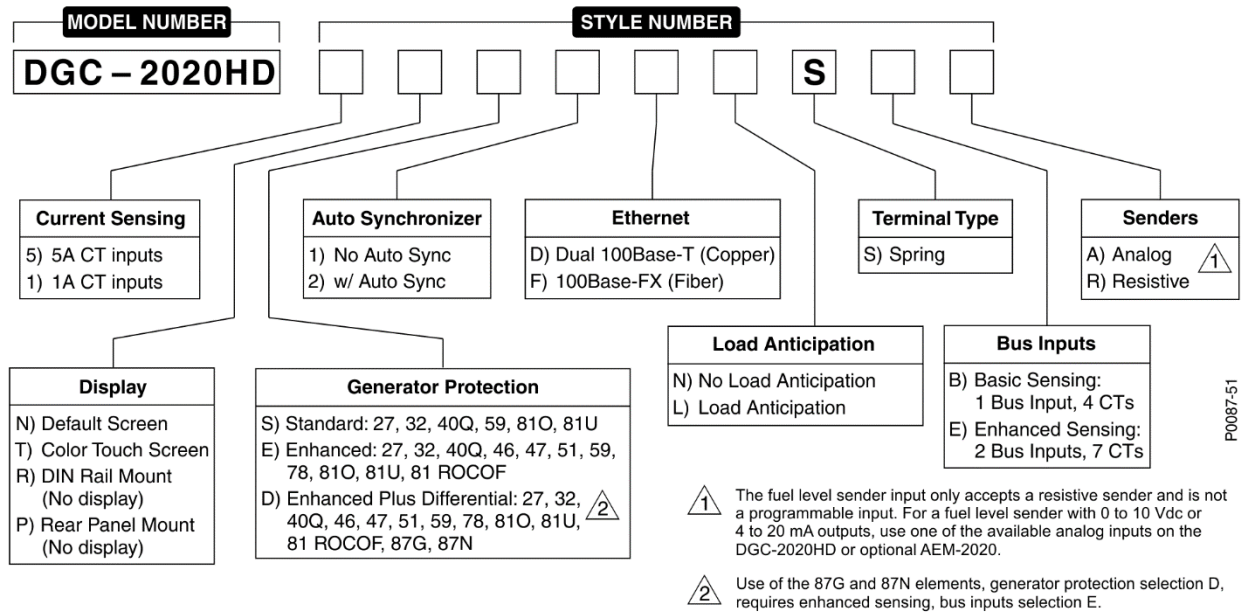

Figure 1-1. DGC-2020HD Style Chart

Optional Features and Capabilities

AEM-2020 (Analog Expansion Module)

The optional AEM-2020 provides eight remote analog inputs, eight remote RTD inputs, two Type-K remote thermocouple inputs, and four remote analog outputs to the DGC-2020HD. The AEM-2020 communicates with the DGC-2020HD through a CAN interface. Up to four AEM-2020s may be used with one DGC-2020HD. Refer to the AEM-2020 chapter in the Accessories manual for more information.

CEM-2020 (Contact Expansion Module)

The optional CEM-2020 provides 10 additional contact inputs and 24 additional output contacts to the DGC-2020HD. The CEM-2020 communicates with the DGC-2020HD through a CAN interface. Up to four CEM-2020s may be used with one DGC-2020HD. Refer to the *CEM-2020* chapter in the *Accessories* manual for more information.

VRM-2020 (Voltage Regulation Module)

The optional Voltage Regulation Module (VRM-2020) communicates with the DGC-2020HD and provides excitation to the field of a brushless exciter. One VRM-2020 may be used with one DGC-2020HD. Refer to the *VRM-2020* chapter in the *Accessories* manual for more information.

BESTCOMSPlus® Settings Loader Tool Software

The optional BESTCOMSPlus Settings Loader Tool allows the user to load pre-determined settings into any BESTCOMSPlus compatible device by simply scanning a bar code. See the *BESTCOMSPlus Settings Loader Tool* chapter in the *Configuration* manual for more information.



2 • Mounting

DGC-2020HD controllers are delivered in sturdy cartons to prevent shipping damage. Upon receipt of a unit, check the part number against the requisition and packing list for agreement. Inspect for damage, and if there is evidence of such, immediately file a claim with the carrier and notify the Basler Electric regional sales office or your sales representative.

If the device is not installed immediately, store it in the original shipping package in a moisture- and dust-free environment.

DGC-2020HD controllers may be mounted in one of three configurations depending on style: Front Panel, DIN Rail, or Rear Panel. These configurations are described in the following paragraphs.

Front Panel Configuration

Units with styles xNxxxxxxx and xTxxxxxxx are mounted through the panel. Four permanently attached 10-24 studs are provided for mounting. The front panel HMI is resistant to moisture, salt fog, humidity, dust, dirt, and chemical contaminants and faces outward for easy access.

Hardware

The torque applied to the mounting hardware should not exceed 20 inch-pounds (2.2 newton meters).

Dimensions

For Front Panel mounting, panel cutting and drilling dimensions are shown in Figure 2-1. All dimensions are shown in inches with millimeters in parenthesis.

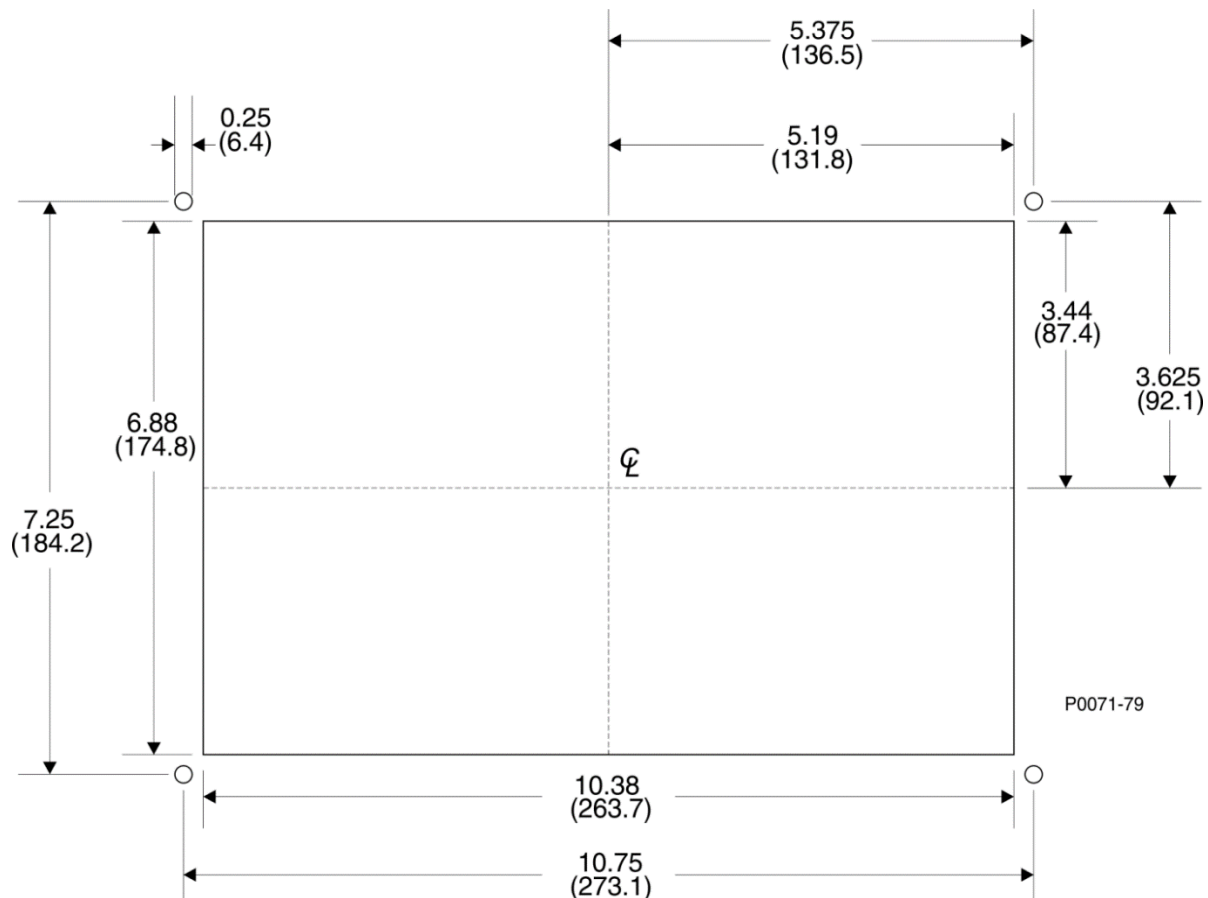

Figure 2-1. Panel Cutting and Drilling Dimensions

In Figure 2-1, the horizontal drilling measurement of 10.75 inches has a tolerance of $+0.01/-0.01$ inches. The horizontal cutout measurement of 10.38 inches has a tolerance of $+0.04/-0$ inches. The vertical drilling measurement of 7.25 inches has a tolerance of $+0.01/-0.01$ inches. The vertical cutout measurement of 6.88 inches has a tolerance of $+0.04/-0$ inches.

DIN Rail Configuration

Units with style xRxxxxxx are mounted on DIN rails. In this configuration, the DGC-2020HD has no HMI. The rear of the DGC-2020HD faces outward for convenient access to terminals and connections. A green LED, located on the rear of the DGC-2020HD, indicates that the unit is powered.

Hardware

Two DIN rails, one located above the other, are required for mounting the DGC-2020HD. One flange and two set screws on the DGC-2020HD secure it to the DIN rails. The flange clips onto the upper rail and the set screws attach to the bottom rail. See Figure 2-2 for flange and set screw locations.

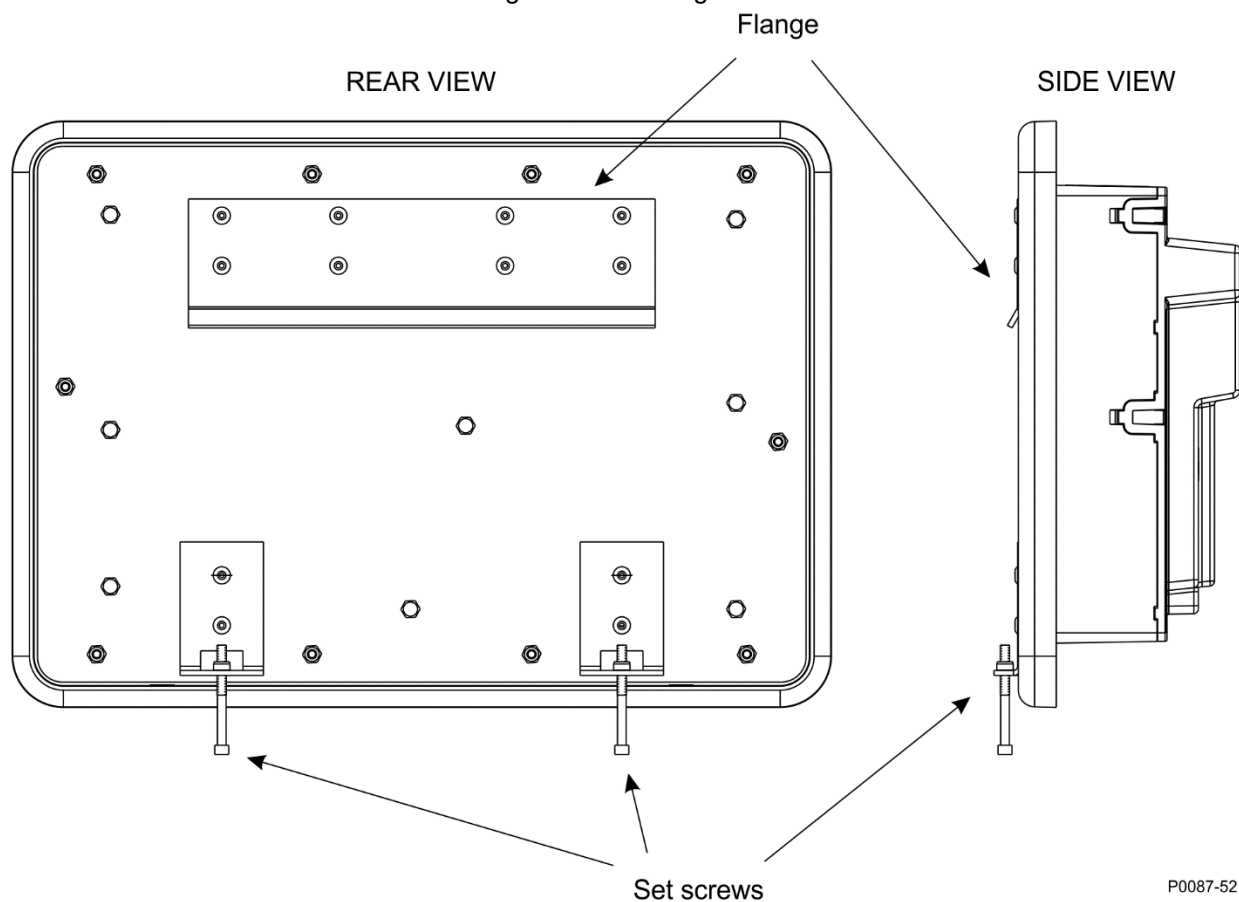

Figure 2-2. DIN Rail Flange and Setscrew Locations for Style xRxxxxxx

Use two steel Top Hat rails, 35 mm x 7.5 mm, that are a minimum of 13 inches (330 mm) in length. DIN Rail mounting hardware should be spaced no more than 6 inches (152 mm) apart for proper support.

Using the supplied hex key, hand tighten set screws until they stop. Locking inserts help maintain set screw tightness. Hand tightening is recommended to ensure proper locking insert performance.

Dimensions

DIN Rail mounting dimensions are shown in Figure 2-3. All dimensions are shown in inches with millimeters in parenthesis.

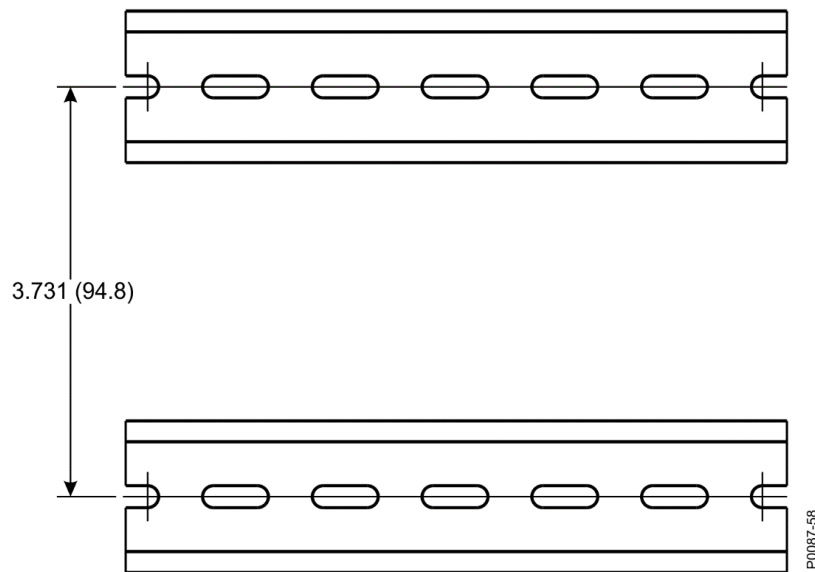

Figure 2-3. DIN Rail Mounting Dimensions for Style xRxxxxxx

Rear Panel

Units with style xPxxxxxx are mounted flush against a panel. In this configuration, the DGC-2020HD has no HMI. Four clearance holes are provided for mounting. The rear of the DGC-2020HD faces outward for convenient access to terminals and connections. A green LED, located on the rear of the DGC-2020HD, indicates that the unit is powered.

Hardware

Use four #10 screws with appropriate hardware. The torque applied to the mounting hardware should not exceed 20 inch-pounds (2.2 newton meters).

Dimensions

For Rear Panel mounting, panel-drilling dimensions are shown in Figure 2-4. All dimensions are shown in inches with millimeters in parenthesis.

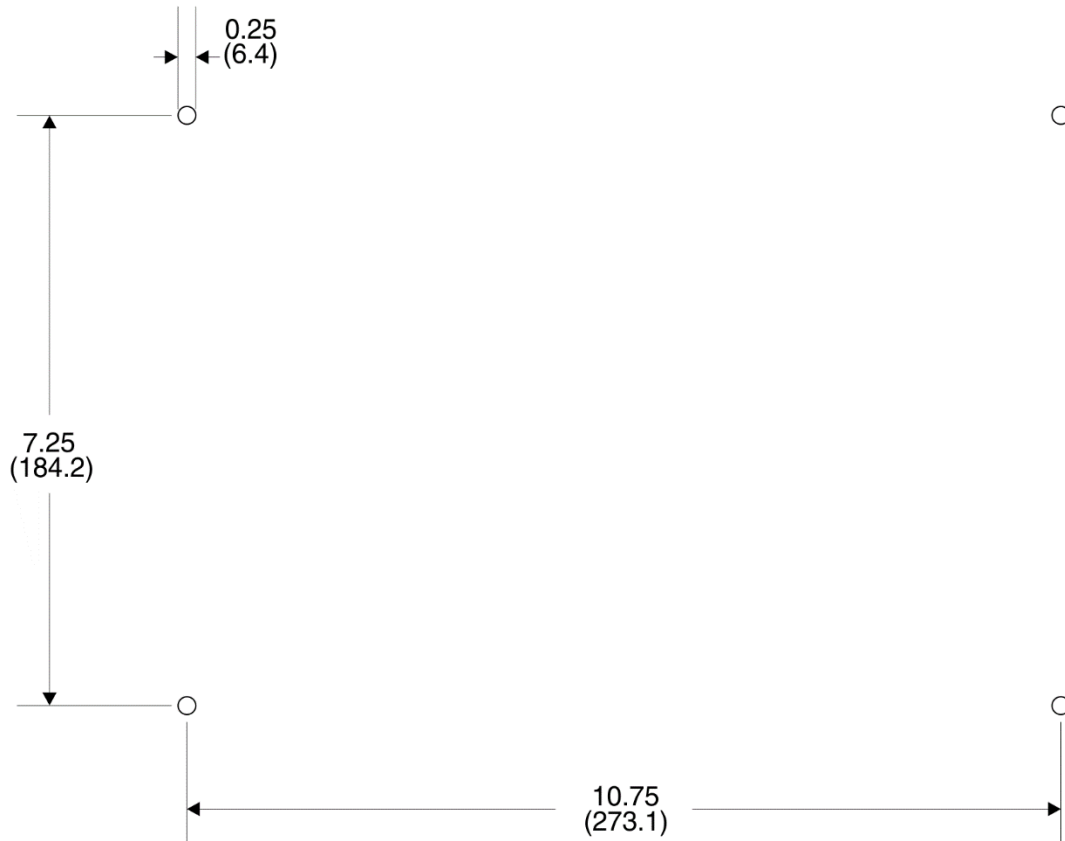

Figure 2-4. Rear Panel Drilling Dimensions for Style xPxxxxxx

P0087-57

Overall Dimensions

Overall dimensions are shown in Figure 2-5. All dimensions are shown in inches with millimeters in parenthesis.

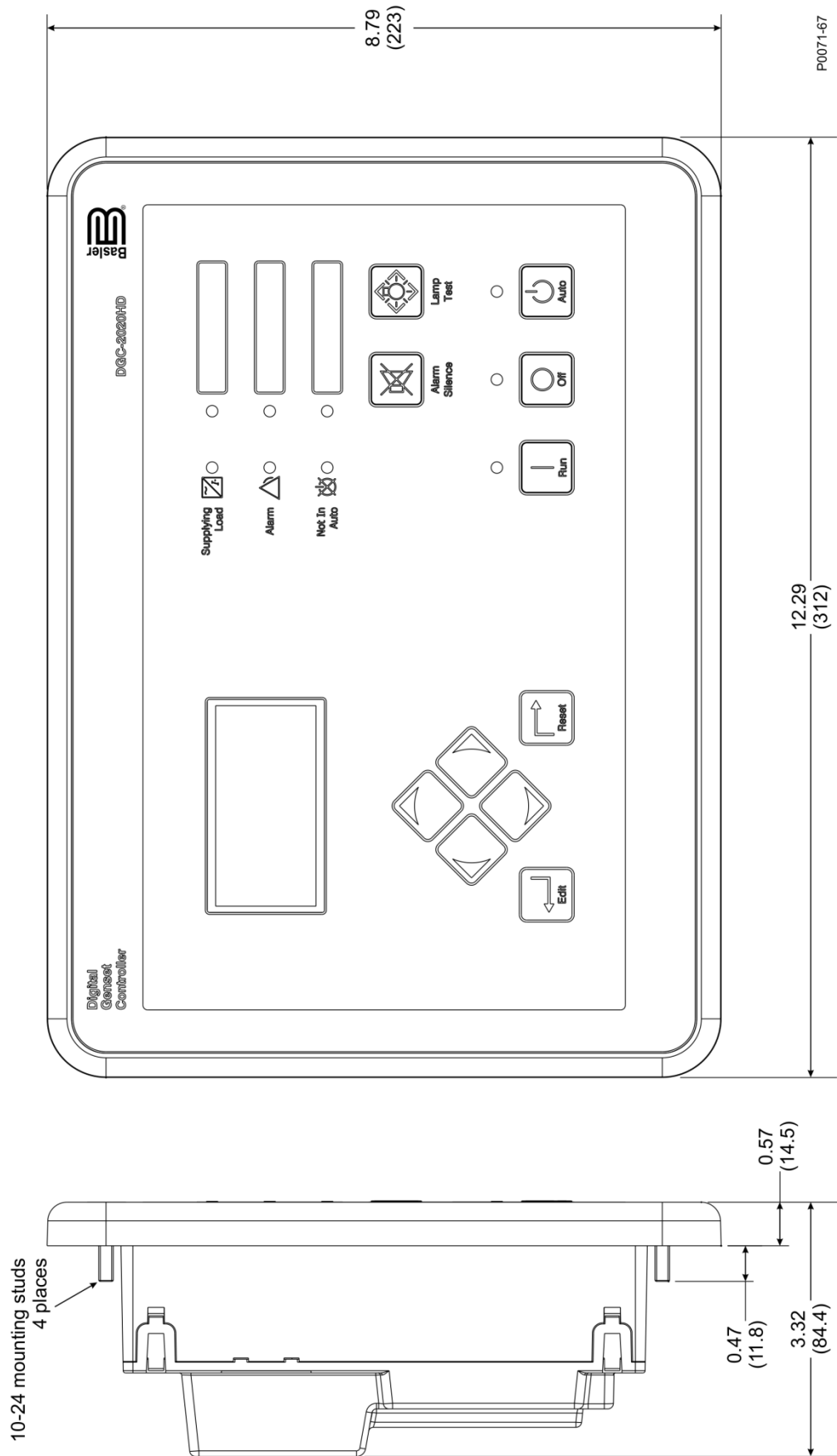

Figure 2-5. Overall Dimensions



3 • Terminals and Connectors

All DGC-2020HD terminals and connectors are located on the rear panel. DGC-2020HD terminals consist of a mini-B USB jack, a DB-9 connector, Ethernet ports, plug-in connectors with spring clamp terminals, and quarter-inch, male, quick-connect terminals.

Figure 3-1 illustrates the rear panel terminals. Locator letters in the illustration correspond to the terminal block and connector descriptions in Table 3-1.

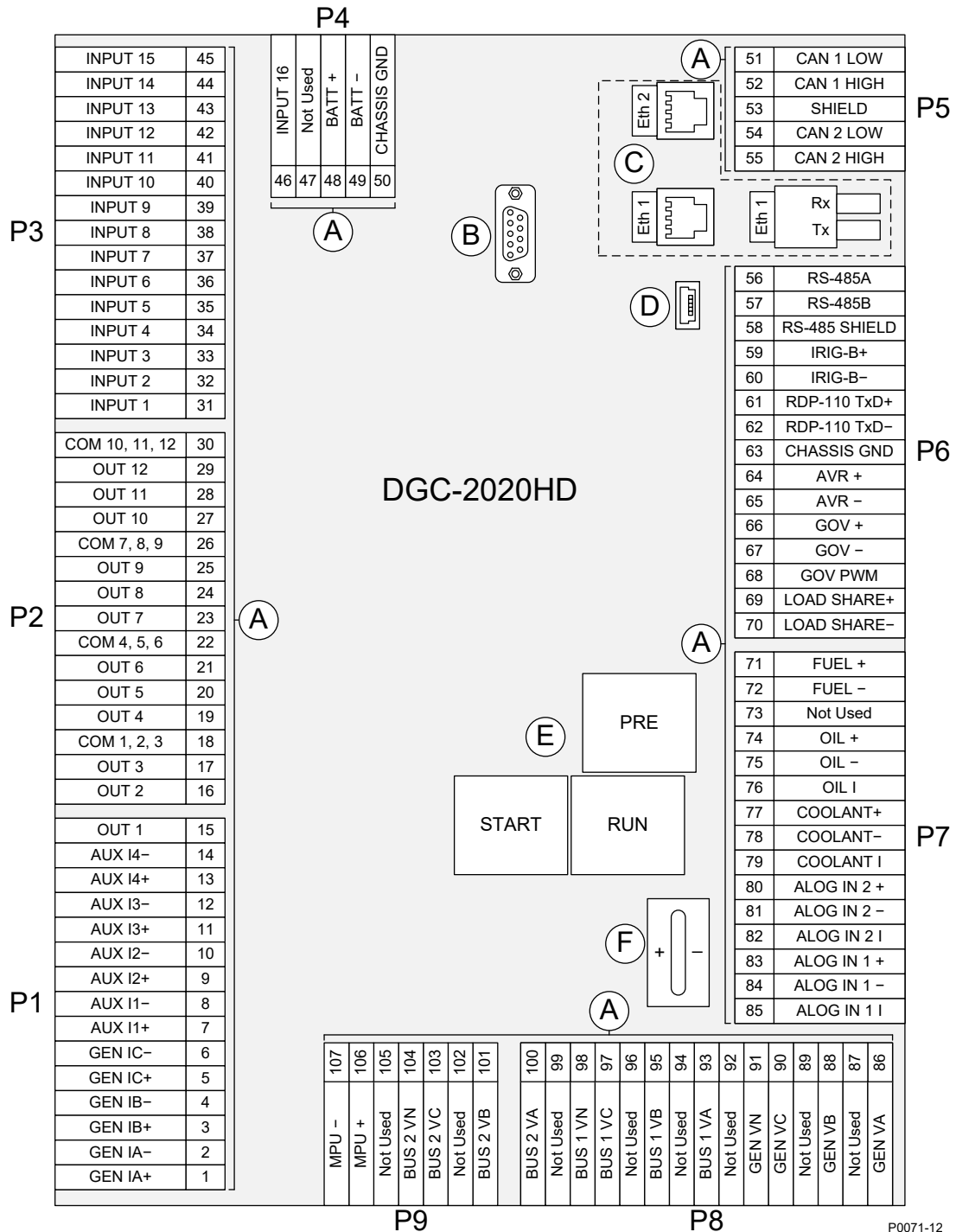

P0071-12

Figure 3-1. Rear Panel

Table 3-1. Rear Panel Terminal and Connector Descriptions

Locator	Description
A	The majority of external, DGC-2020HD wiring is terminated at 5-, 7-, or 15-position connectors with spring clamp terminals. These connectors plug into headers on the DGC-2020HD. The connectors and headers have a dovetailed edge that ensures proper connector orientation. Each connector and header is uniquely keyed to ensure that a connector mates only with the correct header. Terminals accept a maximum wire size of 12 AWG (3.31 mm ²). Remove (strip) 0.4 inch (10 mm) of insulation from each wire end inserted into a connector terminal.
B	This male DB-9 connector is provided for external dial-out modem communication and the future implementation of other communication protocols. Contact Basler Electric for protocol availability.
C	<p>DGC-2020HD Ethernet communication uses the Modbus™ TCP protocol to provide remote metering, annunciation, and control. Dual copper (100Base-T) ports (style xxxxDxxxx) use standard RJ-45 jacks and a fiber optic (100Base-FX) port (style xxxxFxxxx) uses one ST fiber optic connector.</p> <p>Ethernet ports have different designations depending on style:</p> <ul style="list-style-type: none"> • Dual copper (Style xxxxDxxxx) – The RJ-45 jack nearest to the mini-B USB port is designated as Ethernet port 1 and is reserved for intergenset communications (load sharing). The other RJ-45 jack is designated as Ethernet port 2 and can be configured for redundant intergenset communications or for an independent network connection. • Fiber optic (Style xxxxFxxxx) – The ST fiber optic port is designated as Ethernet port 1 and is reserved for intergenset communications (load sharing). <p>Figure 3-1 shows both Ethernet port styles (dual copper and fiber) for clarity. The DGC-2020HD comes equipped with only one port style, not both.</p>
D	The mini-B USB jack mates with a standard USB cable and is used with a PC running BESTCOMSPi ^{us} ® software for local communication with the DGC-2020HD.
E	Connections to the Start, Run, and Pre output contacts are made directly to each relay through quarter-inch, male, quick-connect terminals.
F	An onboard battery maintains DGC-2020HD timekeeping during losses of control power. See the <i>Maintenance</i> chapter in the <i>Installation</i> manual for instructions on replacing the battery. Failure to replace the battery with Basler Electric P/N 38526 may void the warranty.

Note

<p>Be sure that the DGC-2020HD is hard-wired to earth ground with no smaller than 12 AWG (3.31 mm²) copper wire attached to chassis ground (terminal 50) on the rear of the controller.</p>
--

<p>Operating power from the battery must be of the correct polarity. While reverse polarity will not cause damage, the DGC-2020HD will not operate.</p>

4 • Typical Applications

Typical connection diagrams are provided in this chapter as a guide when wiring the DGC-2020HD for communication, mechanical senders, contact inputs and outputs, sensing, and control power.

Connections for Typical Applications

General connections for DGC-2020HD communication, contact inputs, contact outputs, mechanical senders, and control power are shown in Figure 4-1.

General bus voltage sensing connections in three-phase wye, three-phase delta, single-phase A-B and single-phase A-C configurations are shown in the figures listed below.

- Three-phase wye Figure 4-2
- Three-phase delta Figure 4-3
- Single-phase A-B Figure 4-4
- Single-phase A-C Figure 4-5

Connections for pre-configured breaker control schemes are shown in the figures listed below.

- No breaker control Figure 4-6
- Generator breaker control Figure 4-7
- Generator breaker control with optional mains breaker status Figure 4-8
- Generator and mains breaker control Figure 4-9
- Generator and mains breaker control with load bus sensing Figure 4-10
- Generator and group breaker control Figure 4-11
- Generator and group breaker control with load bus sensing Figure 4-12
- Generator, group, and mains breaker control Figure 4-13
- Generator breaker control to segmented system Figure 4-14
- Generator and group breaker control to segmented system Figure 4-15
- Generator and tie breaker control Figure 4-16
- Tie breaker control Figure 4-17
- Dual tie breaker control Figure 4-18

Although three-phase wye sensing connections are shown in the breaker control diagrams, other bus voltage sensing configurations (figures Figure 4-2 through Figure 4-5) may be used instead.

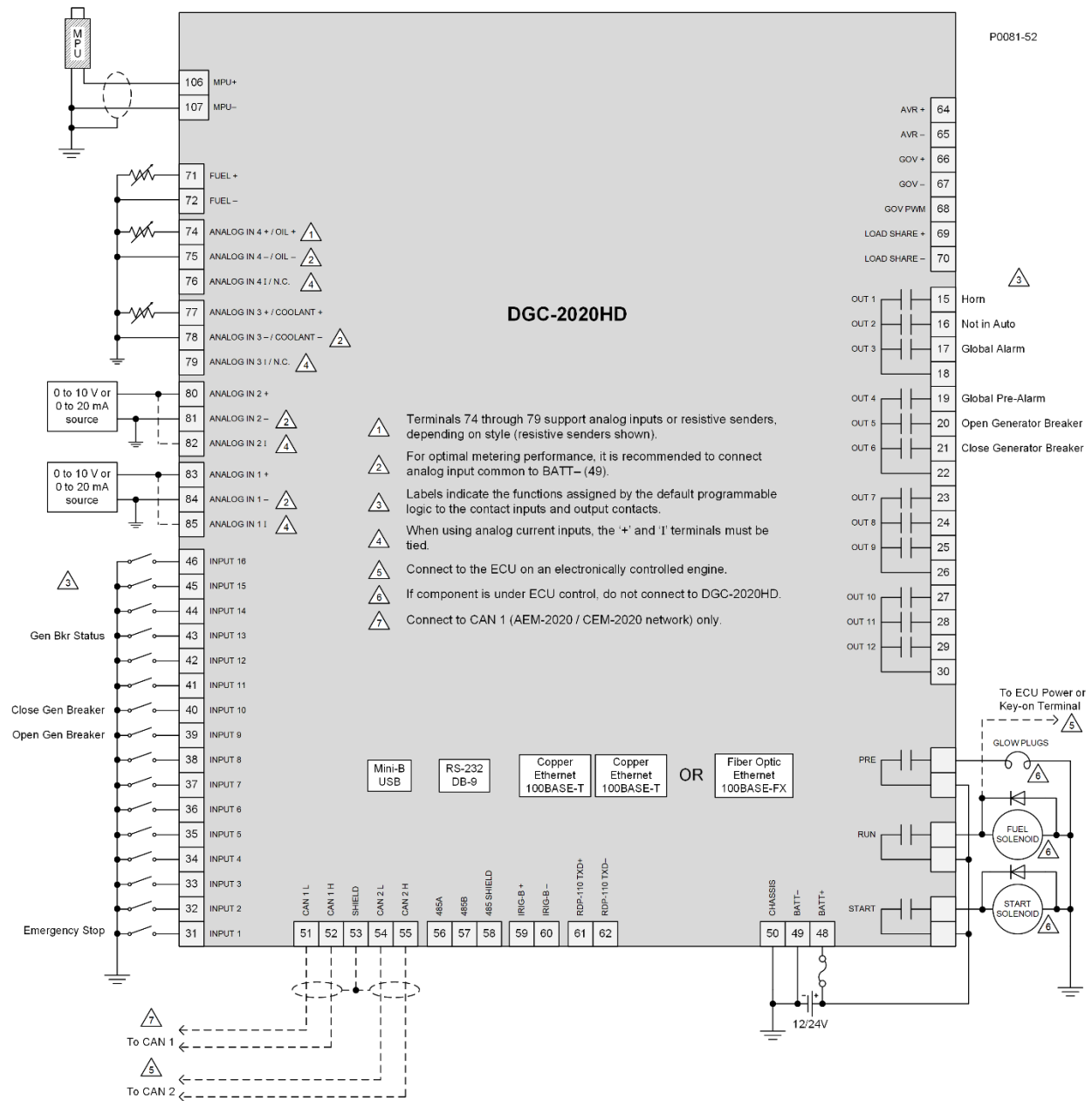

Figure 4-1. Connections for Communication, Senders, Contact Inputs and Outputs, and Control Power

Figure 4-2 illustrates typical three-phase wye connections for all DGC-2020HD bus voltage sensing connections: Generator, Bus 1, and Bus 2. Use the terminal numbers listed below for connecting the desired bus type. Refer to the *Terminals and Connectors* chapter for rear panel terminal numbering.

For Generator voltage sensing, VA = 86, VB = 88, VC = 90, and VN = 91.

For Bus 1 voltage sensing, VA = 93, VB = 95, VC = 97, VN = 98.

For Bus 2 voltage sensing, VA = 100, VB = 101, VC = 103, VN = 104.

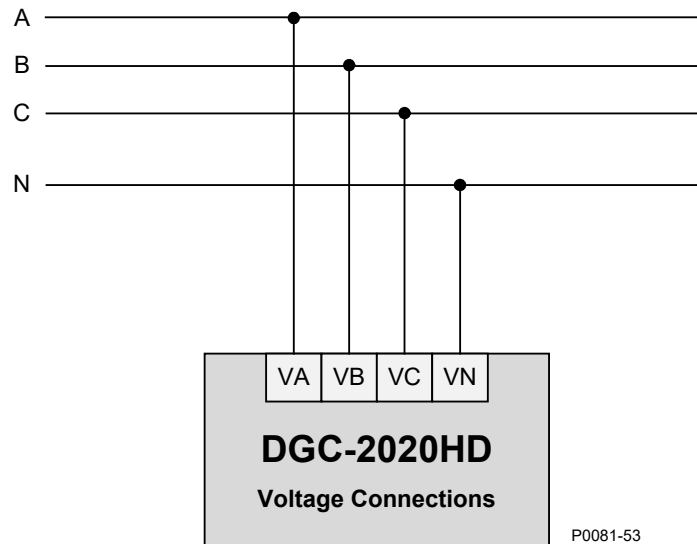

Figure 4-2. 3-Phase Wye Bus Voltage Sensing Connections

Figure 4-3 illustrates typical three-phase delta connections for all DGC-2020HD bus voltage sensing connections: Generator, Bus 1, and Bus 2. Use the terminal numbers listed below for connecting the desired bus type. Refer to the *Terminals and Connectors* chapter for rear panel terminal numbering.

For Generator voltage sensing, VA = 86, VB = 88, and VC = 90.

For Bus 1 voltage sensing, VA = 93, VB = 95, and VC = 97.

For Bus 2 voltage sensing, VA = 100, VB = 101, and VC = 103.

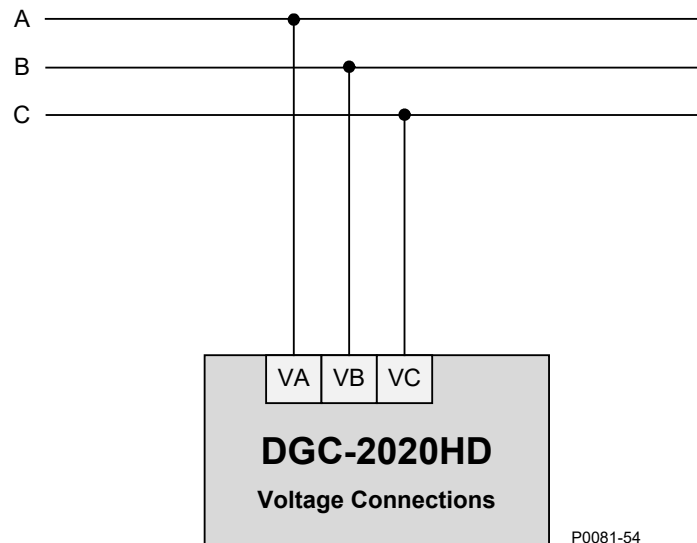

Figure 4-3. 3-Phase Delta Connections

Figure 4-4 illustrates typical single-phase A-B connections for all DGC-2020HD bus voltage sensing connections: Generator, Bus 1, and Bus 2. Use the terminal numbers listed below for connecting the desired bus type. Refer to the *Terminals and Connectors* chapter for rear panel terminal numbering.

For Generator voltage sensing, VA = 86, VB = 88, and VN = 91.

For Bus 1 voltage sensing, VA = 93, VB = 95, VN = 98.

For Bus 2 voltage sensing, VA = 100, VB = 101, VN = 104.

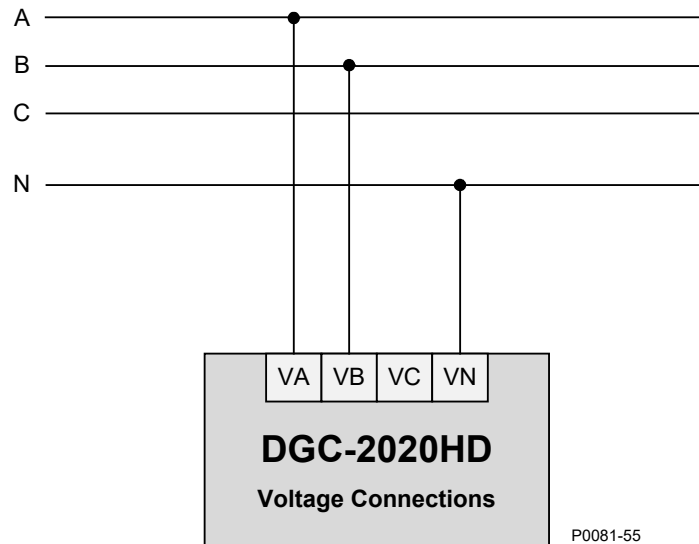

Figure 4-4. Single-Phase A-B Connections

Figure 4-5 illustrates typical single-phase A-C connections for all DGC-2020HD bus voltage sensing connections: Generator, Bus 1, and Bus 2. Use the terminal numbers listed below for connecting the desired bus type. Refer to the *Terminals and Connectors* chapter for rear panel terminal numbering.

For Generator voltage sensing, VA = 86, VC = 90, and VN = 91.

For Bus 1 voltage sensing, VA = 93, VC = 97, VN = 98.

For Bus 2 voltage sensing, VA = 100, VC = 103, VN = 104.

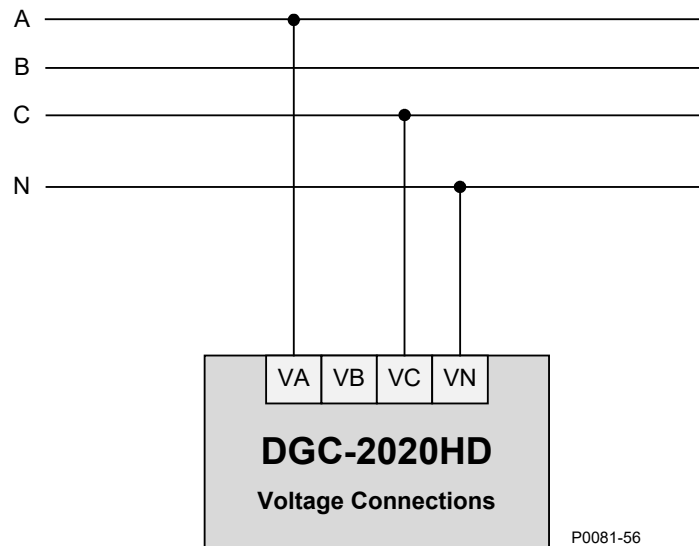

Figure 4-5. Single-Phase A-C Connections

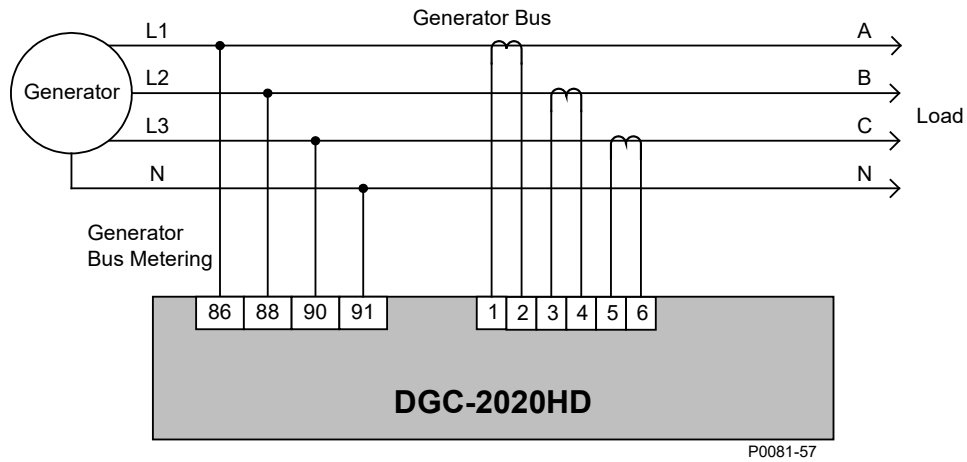

Figure 4-6. No Breaker Control Connections

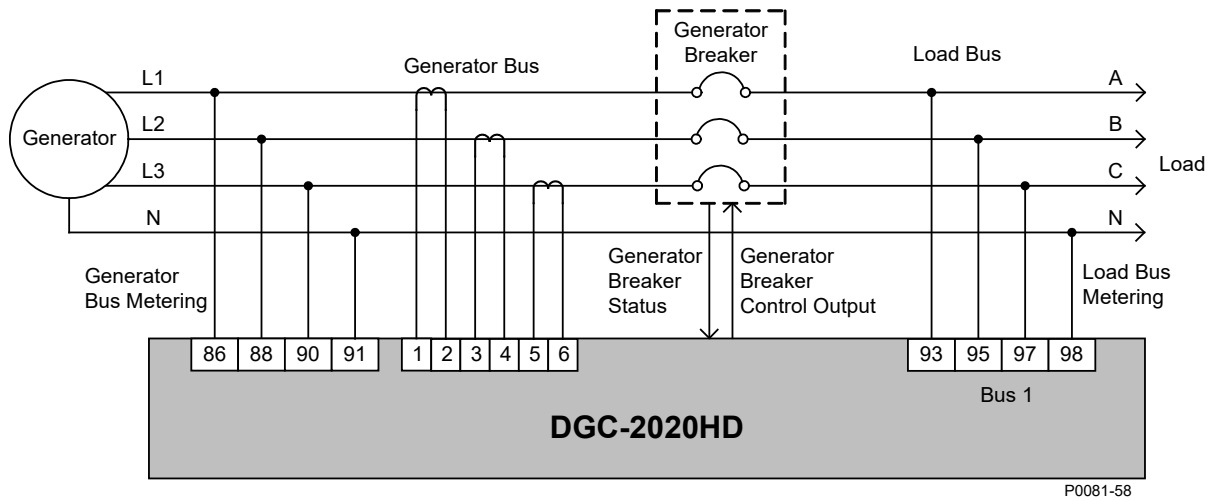
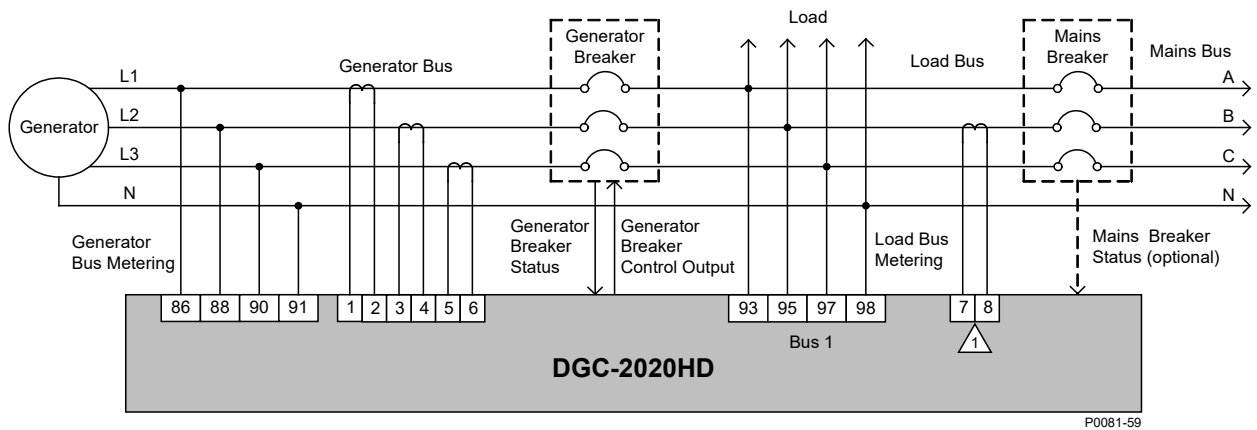
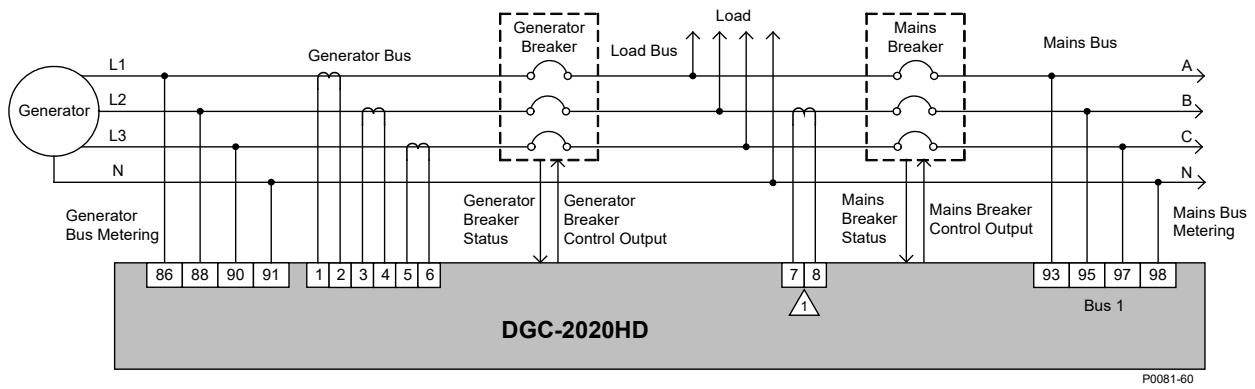

Figure 4-7. Generator Breaker Control Connections



Notes:
 ⚠ An auxiliary CT is only required for mains breaker power measurement. Mains breaker power measurement is required for the Zero Power Transfer or Mains Power Control functions.

Figure 4-8. Generator Breaker Control Connections with Optional Mains Breaker Status



Notes:
 1 An auxiliary CT is only required for mains breaker power measurement. Mains breaker power measurement is required for the Zero Power Transfer or Mains Power Control functions.

Figure 4-9. Generator and Mains Breaker Control Connections

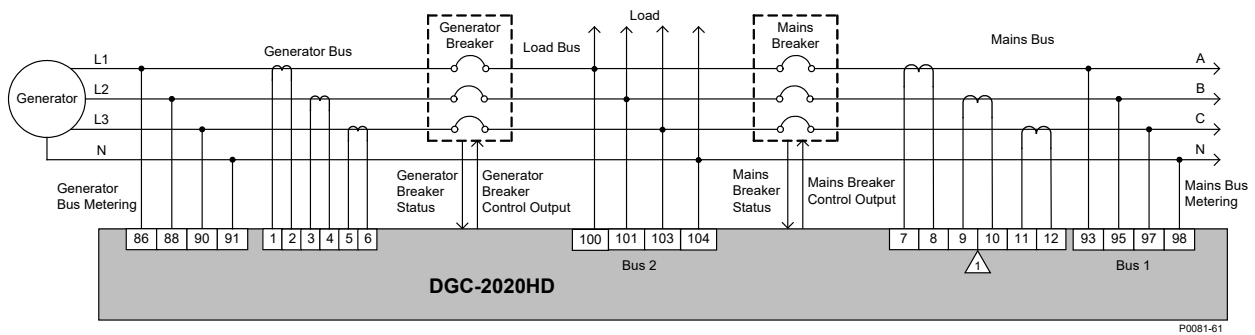

Notes:
 1 An auxiliary CT is only required for mains breaker power measurement. Mains breaker power measurement is required for the Zero Power Transfer or Mains Power Control functions.

Figure 4-10. Generator and Mains Breaker Control with Load Bus Sensing Connections

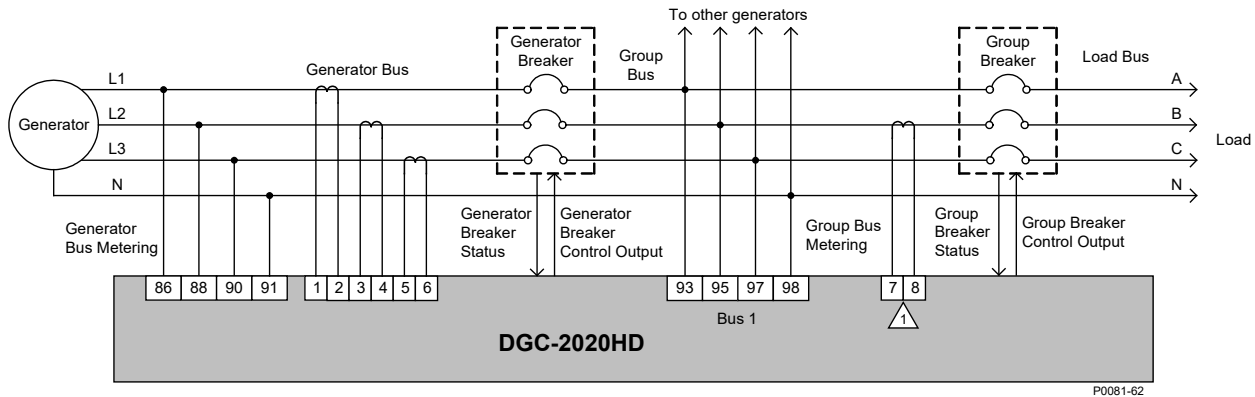

Notes:
 1 An auxiliary CT is only required if group breaker power measurement is desired. Group breaker power measurement is required for the group breaker Zero Power Transfer function.

Figure 4-11. Generator and Group Breaker Control Connections

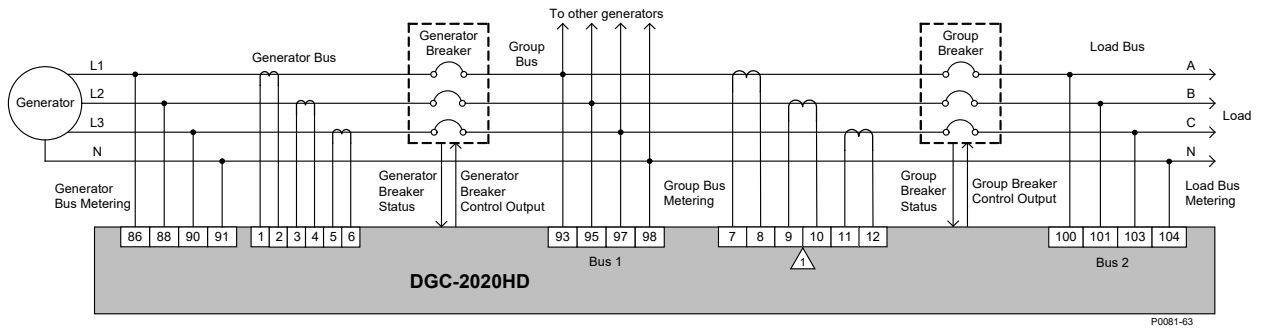

Notes:
 ⚠ An auxiliary CT is only required if group breaker power measurement is desired. Group breaker power measurement is required for the group breaker Zero Power Transfer function.

Figure 4-12. Generator and Group Breaker Control with Load Bus Sensing Connections

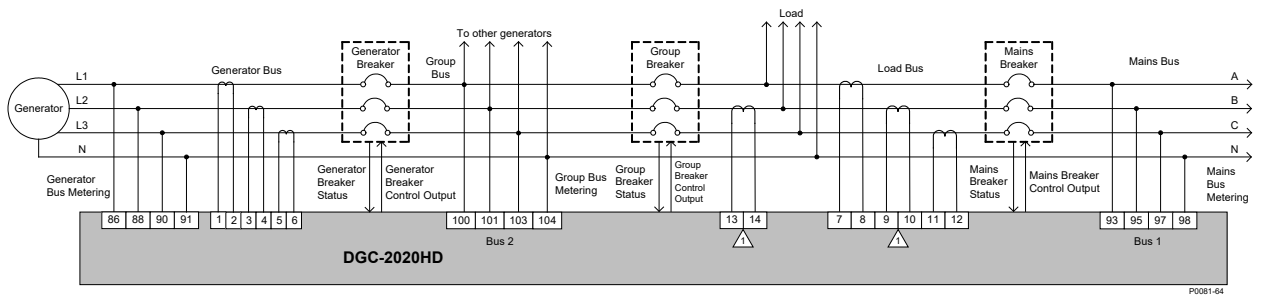

Notes:
 ⚠ Auxiliary CTs are only required if mains breaker and/or group breaker power measurement is desired. Power measurement through the group or mains breaker is required for Zero Power Transfer through that breaker. Mains breaker power measurement is required for the Mains Power Control function.

Figure 4-13. Generator, Group, and Mains Breaker Control Connections

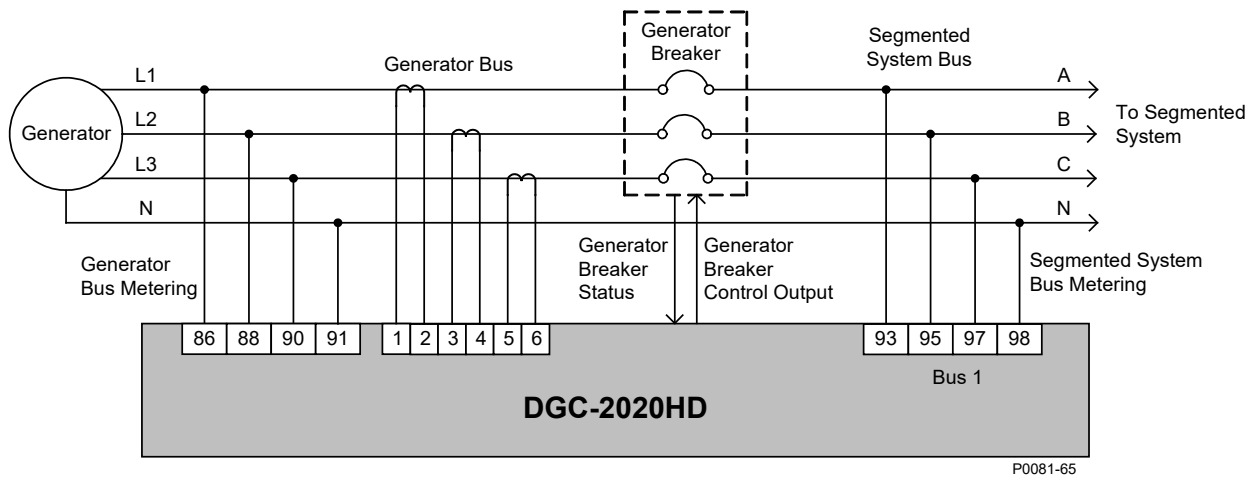
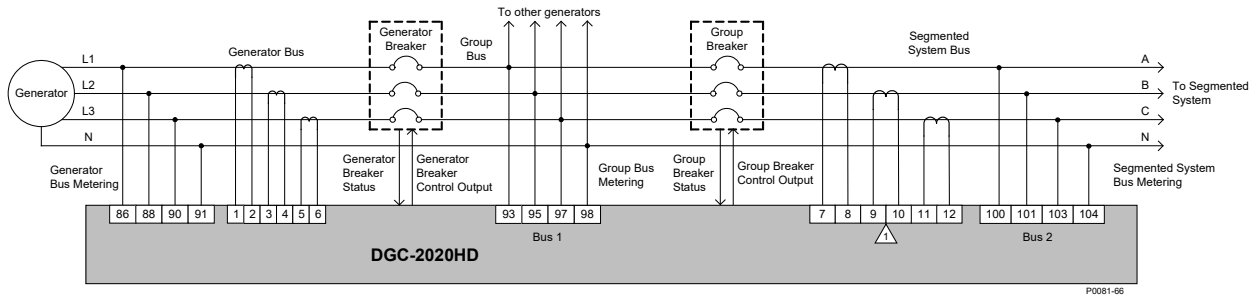
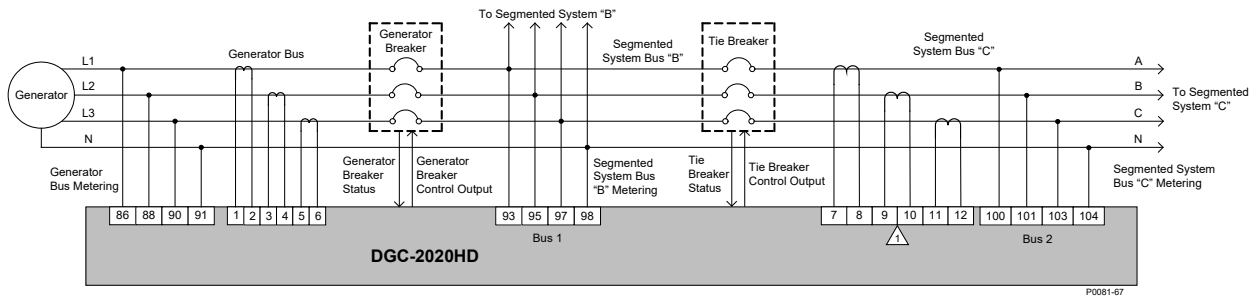

Figure 4-14. Generator Breaker Control to Segmented System Connections



Notes:
 ⚠ An auxiliary CT is only required if group breaker power measurement is desired. Group breaker power measurement is required for the group breaker Zero Power Transfer function.

Figure 4-15. Generator and Group Breaker Control to Segmented System Connections



Notes:
 ⚠ Auxiliary CTs are only required if tie breaker power measurement is desired. Tie breaker power measurement is required for the Zero Power Transfer function across the tie breaker.

Figure 4-16. Generator and Tie Breaker Control Connections

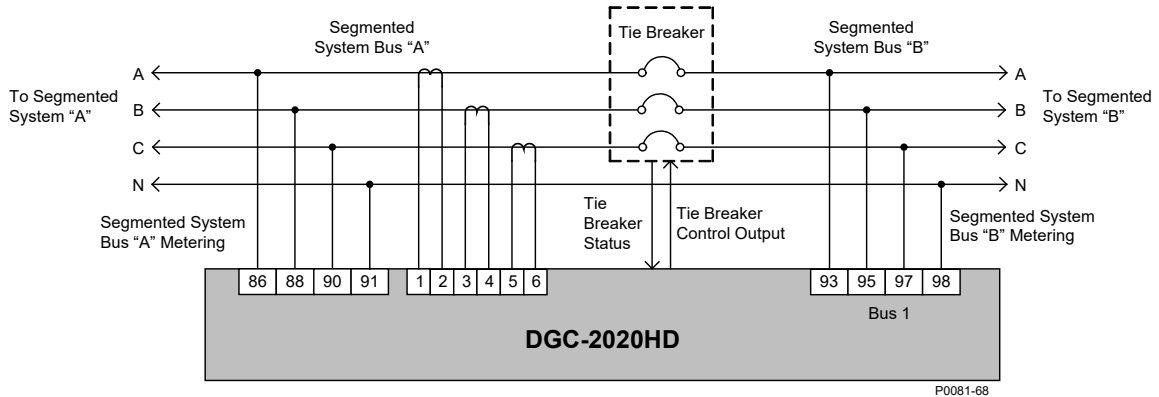
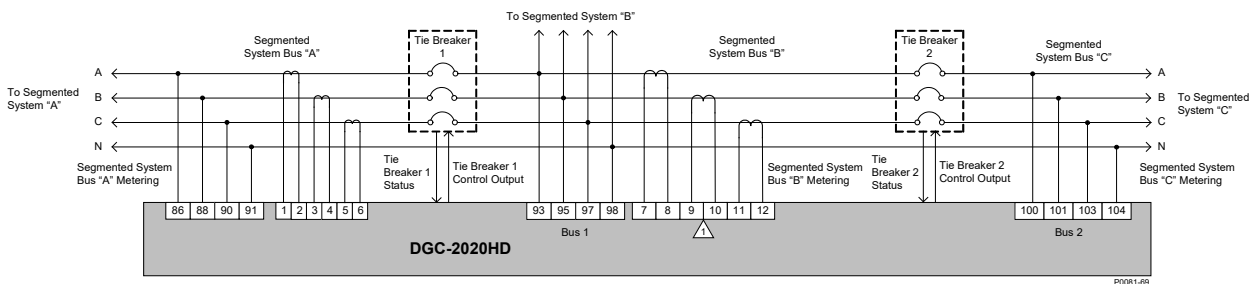

Figure 4-17. Tie Breaker Control Connections





Notes:
 ⚠ Auxiliary CTs are only required if Tie Breaker 2 power measurement is desired. Tie Breaker 2 power measurement is required for the Zero Power Transfer function across Tie Breaker 2.

Figure 4-18. Dual Tie Breaker Control Connections

Connections for Load Sharing

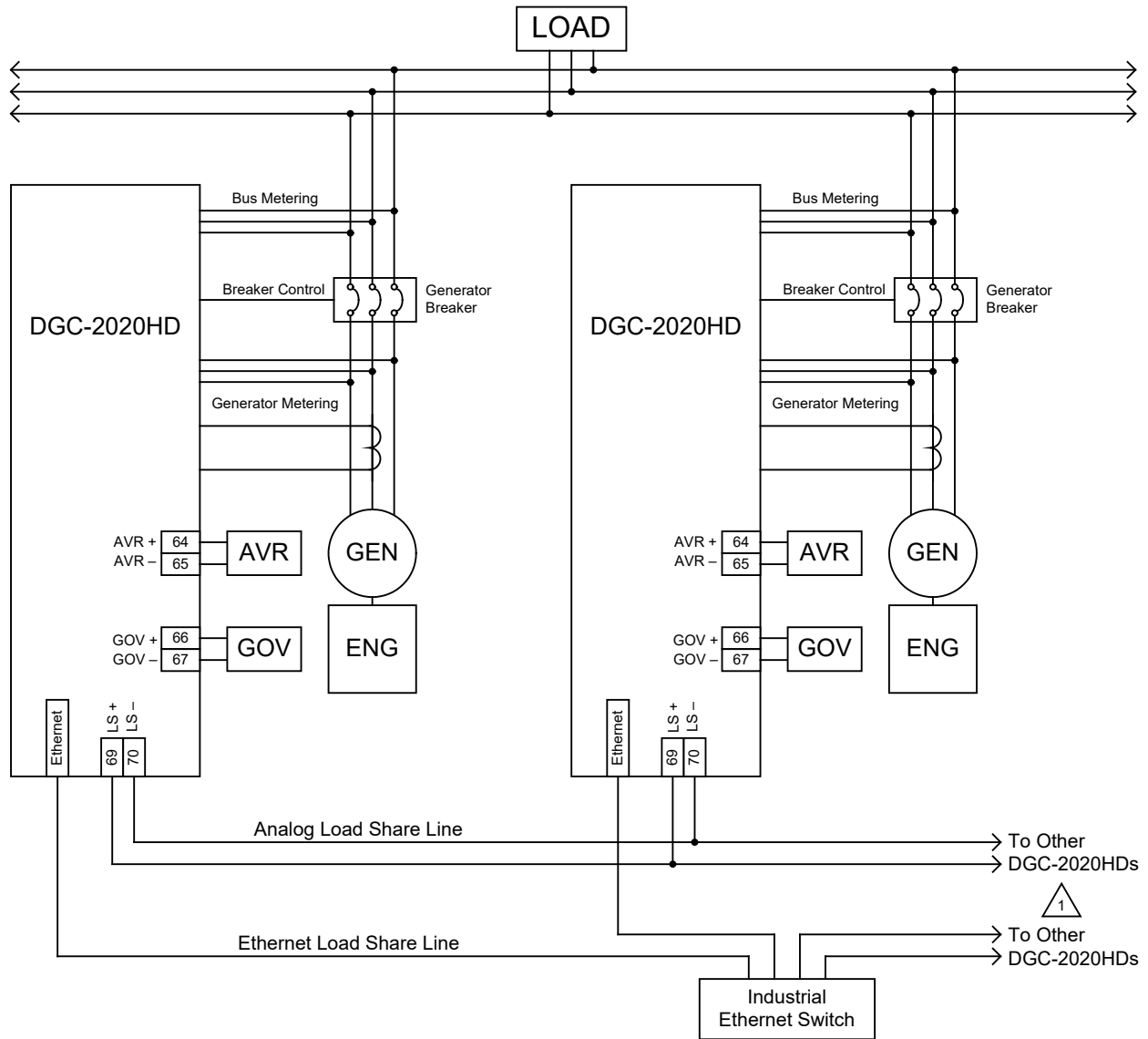
Figure 4-19 illustrates a typical interconnection of two systems tied together using analog and Ethernet load share lines.



Notes:  Up to 32 DGC-2020HDs are supported on one network.

P0071-68

Figure 4-19. Analog and Ethernet Connections for Typical Applications

Analog Input Connections

DGC-2020HD controllers with style number xxxxxxxR are equipped with two analog inputs and those with style number xxxxxxxA are equipped with four analog inputs.

Voltage and current analog input connections are shown in Figure 4-20. When using the current input, the “+” and “I” terminals must be tied together.

Analog Voltage Input Connection

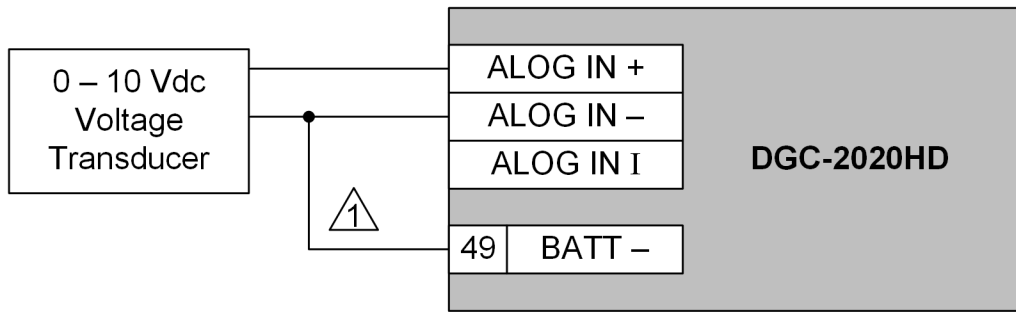

Analog Current Input Connection

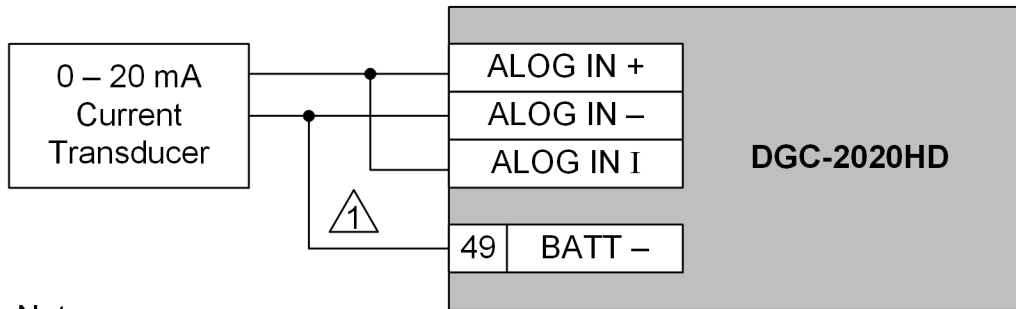

Note:

 For optimal metering performance, it is recommended to connect analog input common to terminal 49 (BATT -).

P0071-65

Figure 4-20. Analog Engine Sender Voltage Input Connections

Governor PWM Output Connections

Governor PWM output allows interfacing with select CAT control systems. Governor PWM output connections are shown in Figure 4-21.

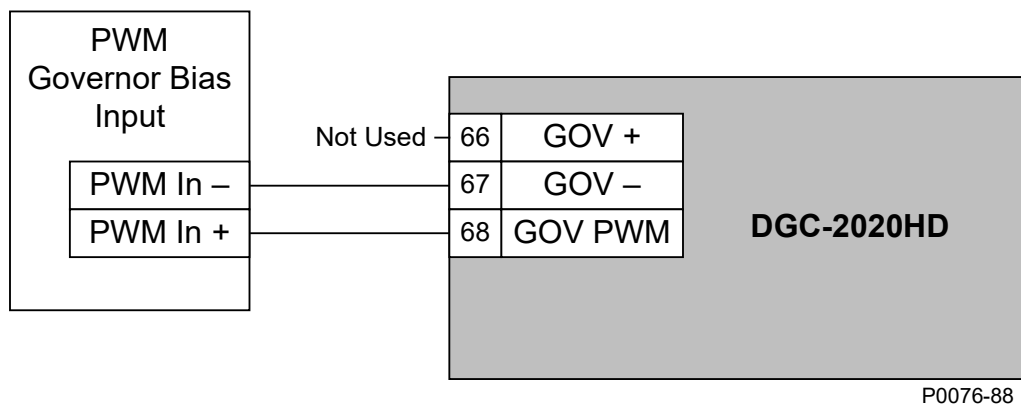

P0076-88

Figure 4-21. Governor PWM Output Connections

CAN Connections

Typical CAN connections are shown in Figure 4-22 and Figure 4-23.

Notes

1. If the DGC-2020HD is providing one end of the J1939 bus, a 120 ohm, ½ watt terminating resistor should be installed across terminals 51 (CAN1L) and 52 (CAN1H) or 54 (CAN2L) and 55 (CAN2H).
2. If the DGC-2020HD is not providing one end of the J1939 bus, the stub connecting the DGC-2020HD to the bus should not exceed 914 mm (3 ft) in length.
3. The maximum bus length, not including stubs, is 40 m (131 ft).
4. The J1939 drain (shield) should be grounded at one point only. If grounded elsewhere, do not connect the drain to the DGC-2020HD.
5. It is recommended to upgrade the firmware in all AEM-2020s and CEM 2020s that share a CAN bus network with a VRM-2020. Upgrade CEM-2020s to firmware version 1.01.05 or later. Upgrade AEM 2020s to firmware version 1.00.06 or later.

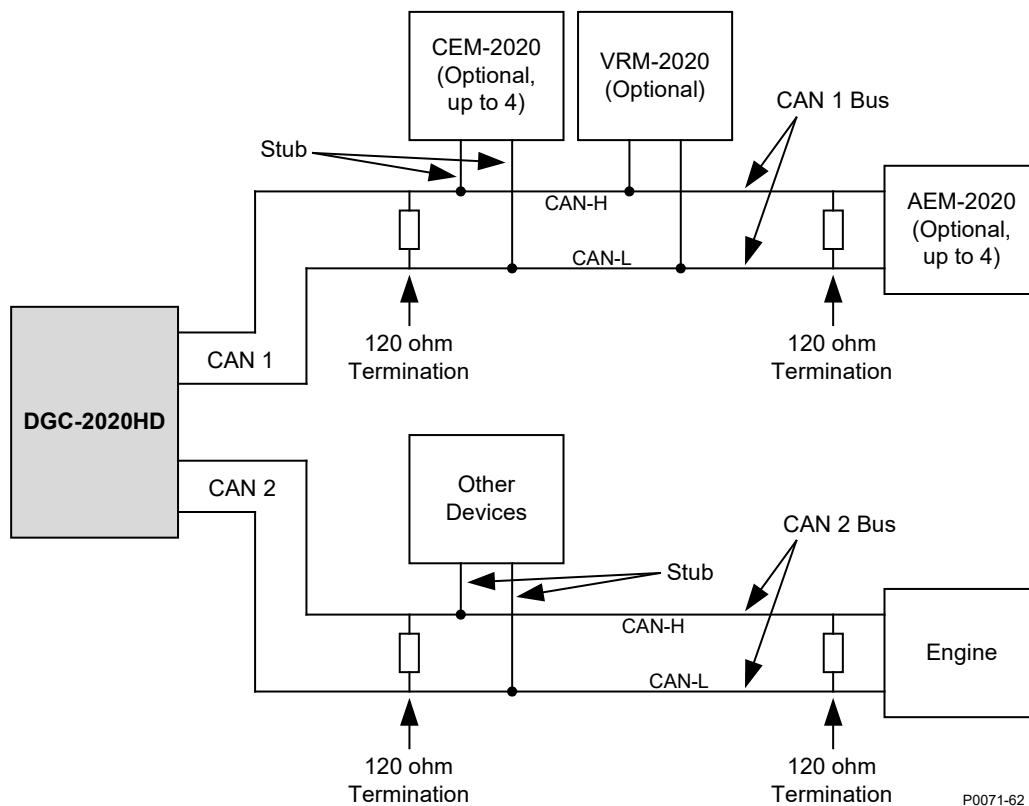

Figure 4-22. CAN Interface with DGC-2020HD Providing One End of the Bus

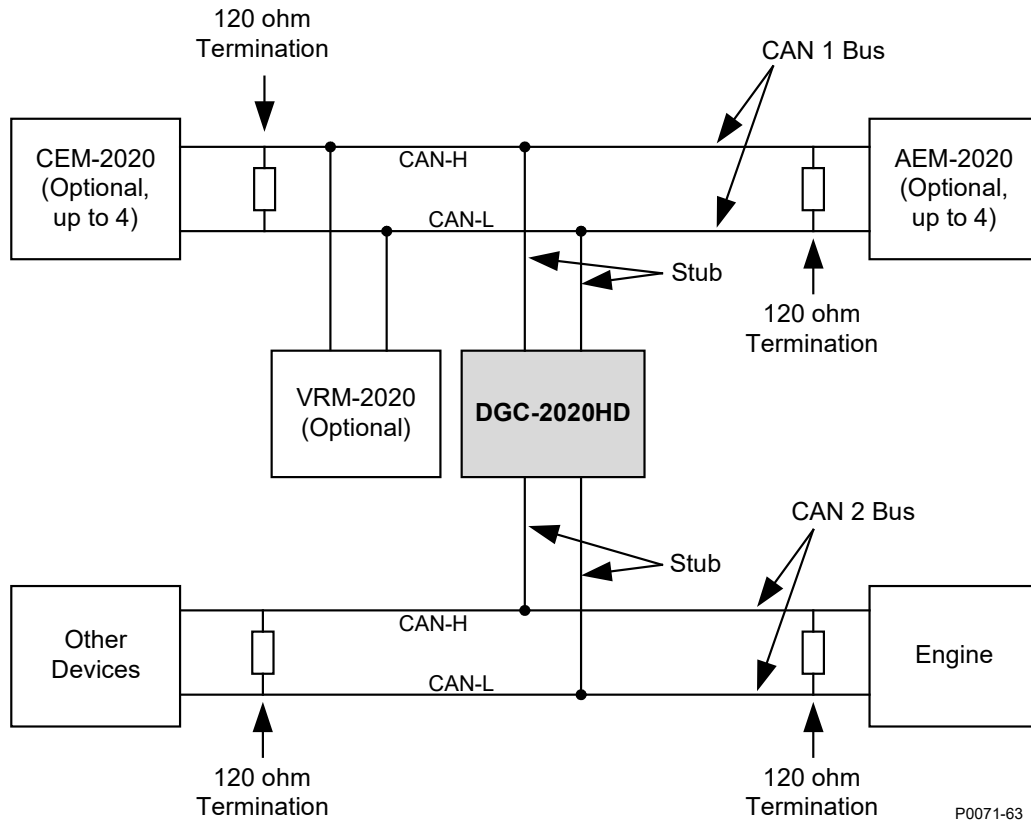

Figure 4-23. CAN Interface with Other Devices Providing One End of the Bus.

Expansion Module Connections (CAN 1)

The AEM-2020 (Analog Expansion Module), CEM-2020 (Contact Expansion Module), and VRM-2020 (Voltage Regulation Expansion Module) are optional modules that may be connected with the DGC-2020HD. These modules interface to the DGC-2020HD via the “CAN 1” interface, thus the CAN terminals (51, 52, and 53) are the only common connections between the DGC-2020HD, AEM-2020, CEM-2020, and VRM-2020. Up to four CEM-2020 modules, up to four AEM-2020 modules, and one VRM-2020 module are supported on a CAN configured for 250 kbps. On a CAN configured for 125 kbps, only up to two AEM-2020 modules are supported if a VRM-2020 is used. Typical connections are illustrated in Figure 4-24.

Refer to the *AEM-2020*, *CEM-2020*, and *VRM-2020* chapters in the *Accessories* manual for more information.

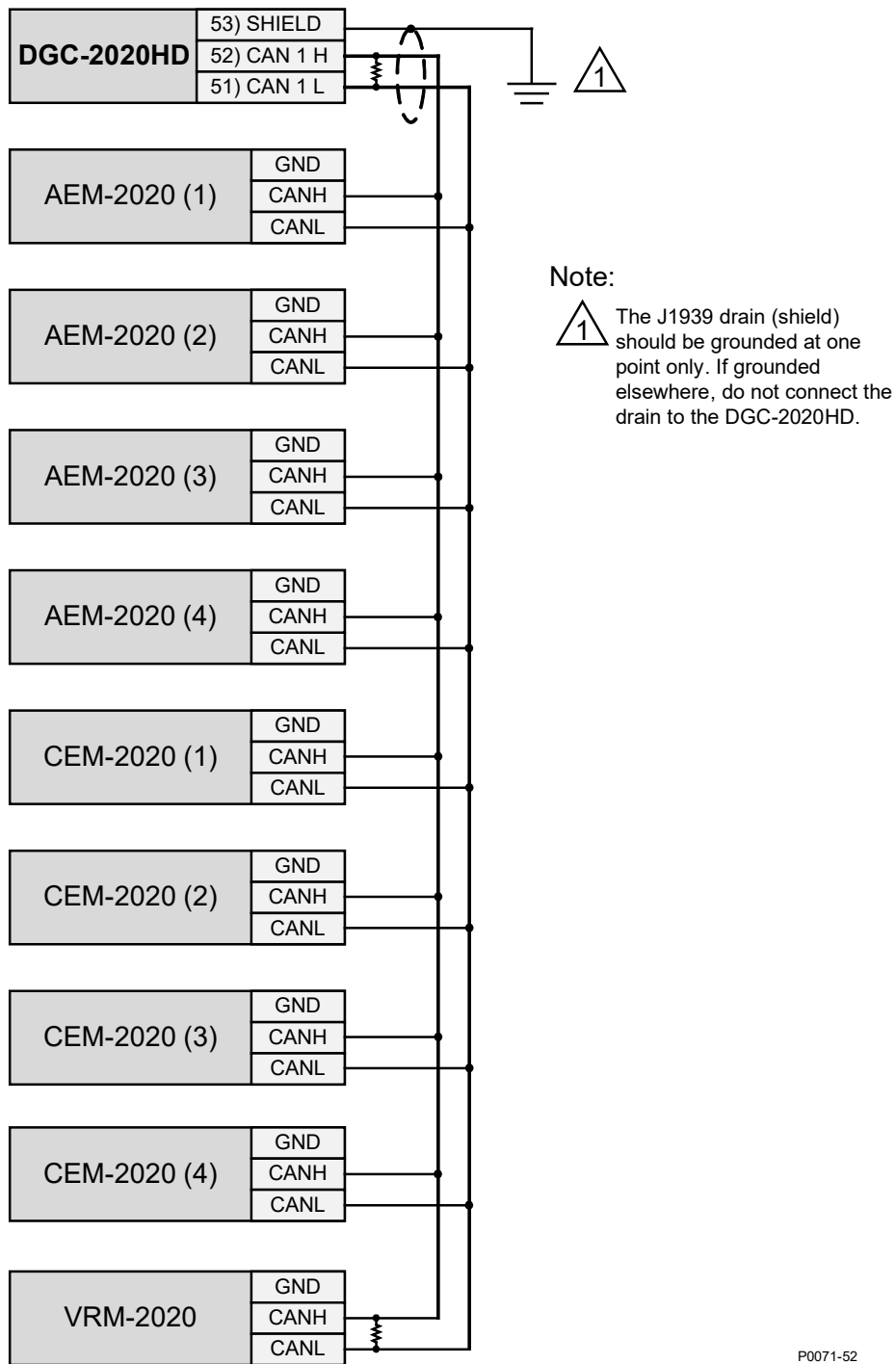

Figure 4-24. DGC-2020HD Expansion Module CAN Connections

Installation for CE Systems

For CE compliant systems, it may be required to route ac voltage and current sensing wires separately from other wires.

Installation in an Ungrounded System Application

When the DGC-2020HD is controlling equipment that is part of an ungrounded system, it is recommended that potential transformers be employed on the voltage sensing inputs to provide full isolation between the DGC-2020HD and monitored voltage phases.

5 • BESTCOMSPi[®] Software

BESTCOMSPi[®] provides the user with a point-and-click means to set and monitor the DGC-2020HD. BESTCOMSPi[®] uses plugins, allowing the user to manage several different Basler Electric products.

Figure 5-1 illustrates the typical user interface components of the DGC-2020HD plugin with BESTCOMSPi[®].

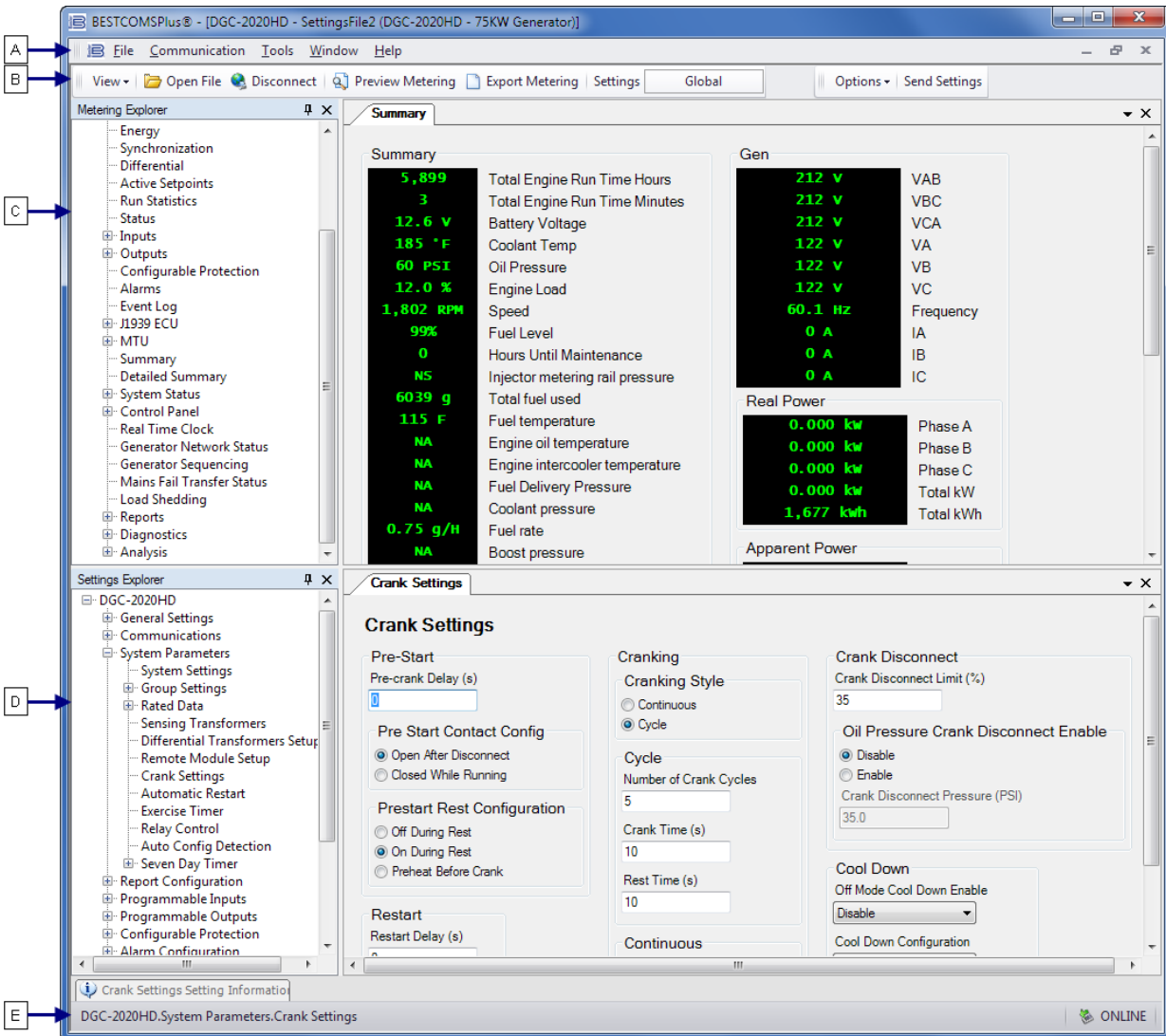

Figure 5-1. Typical User Interface Components

Table 5-1. Definitions for Locators in Figure 5-1.

Locator	Component
A	Upper Menu Bar
B	Lower Menu Bar
C	Metering Explorer
D	Settings Explorer
E	Status Bar

Installation

Note

Do not connect a USB cable until setup completes successfully. Connecting a USB cable before setup is complete may result in errors.

1. Download BESTCOMSP*lus* from www.basler.com.
2. Click the installation button for BESTCOMSP*lus*. The setup utility installs BESTCOMSP*lus*, the .NET Framework (if not already installed), the USB driver, and the DGC-2020HD plugin for BESTCOMSP*lus* on your PC.

When BESTCOMSP*lus* installation is complete, a Basler Electric folder is added to the Windows programs menu. This folder is accessed by clicking the Windows Start button and then accessing the Basler Electric folder in the Programs menu. The Basler Electric folder contains an icon that starts BESTCOMSP*lus* when clicked.

Connect the DGC-2020HD and Start BESTCOMSP*lus*[®]

The DGC-2020HD plugin is a module that runs inside the BESTCOMSP*lus* shell. The DGC-2020HD plugin contains specific operational and logic settings for only the DGC-2020HD.

Connect a USB Cable

The USB driver was copied to your PC during BESTCOMSP*lus* installation and is installed automatically after powering the DGC-2020HD. USB driver installation progress is shown in the Windows taskbar area. Windows will notify you when installation is complete.

Connect a USB cable between the PC and your DGC-2020HD. Apply control power to the DGC-2020HD. Wait until the boot sequence is complete.

Note

In some instances, the Found New Hardware Wizard will prompt you for the USB driver. If this happens, direct the wizard to the following folder: C:\Program Files\Basler Electric\USB Connect Driver\

If the USB driver does not install properly, refer to the *Troubleshooting* chapter in the *Configuration* manual.

Start BESTCOMSP*lus*[®]

To start BESTCOMSP*lus*, click the Windows Start button, point to Programs, Basler Electric, and then click the BESTCOMSP*lus* icon. During initial startup, the BESTCOMSP*lus* Select Language screen is displayed (Figure 5-2). You can choose to have this screen displayed each time BESTCOMSP*lus* is started, or you can select a preferred language and this screen will be bypassed in the future. Click OK to continue. This screen can be accessed later by selecting Tools and Select Language from the menu bar.

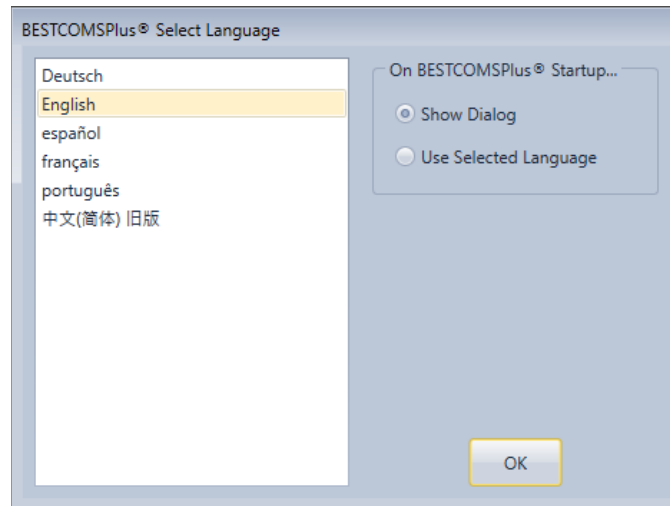

Figure 5-2. BESTCOMSPPlus Language Selection Dialog

The BESTCOMSPPlus platform window opens. Select New Connection from the Communication pull-down menu and select DGC-2020HD. See Figure 5-3.

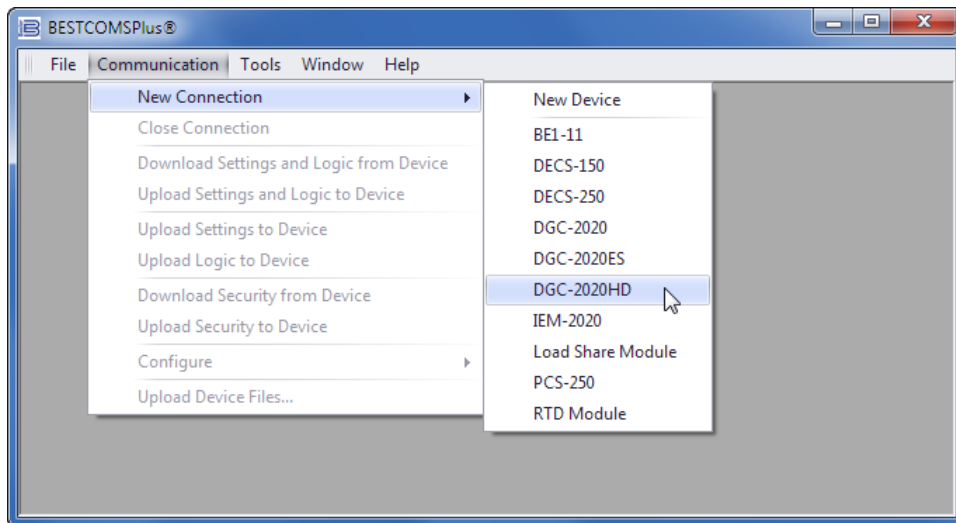

Figure 5-3. Communication Pull-Down Menu

The DGC-2020HD Connection screen, shown in Figure 5-4 appears. Select USB Connection and then click the Connect button.

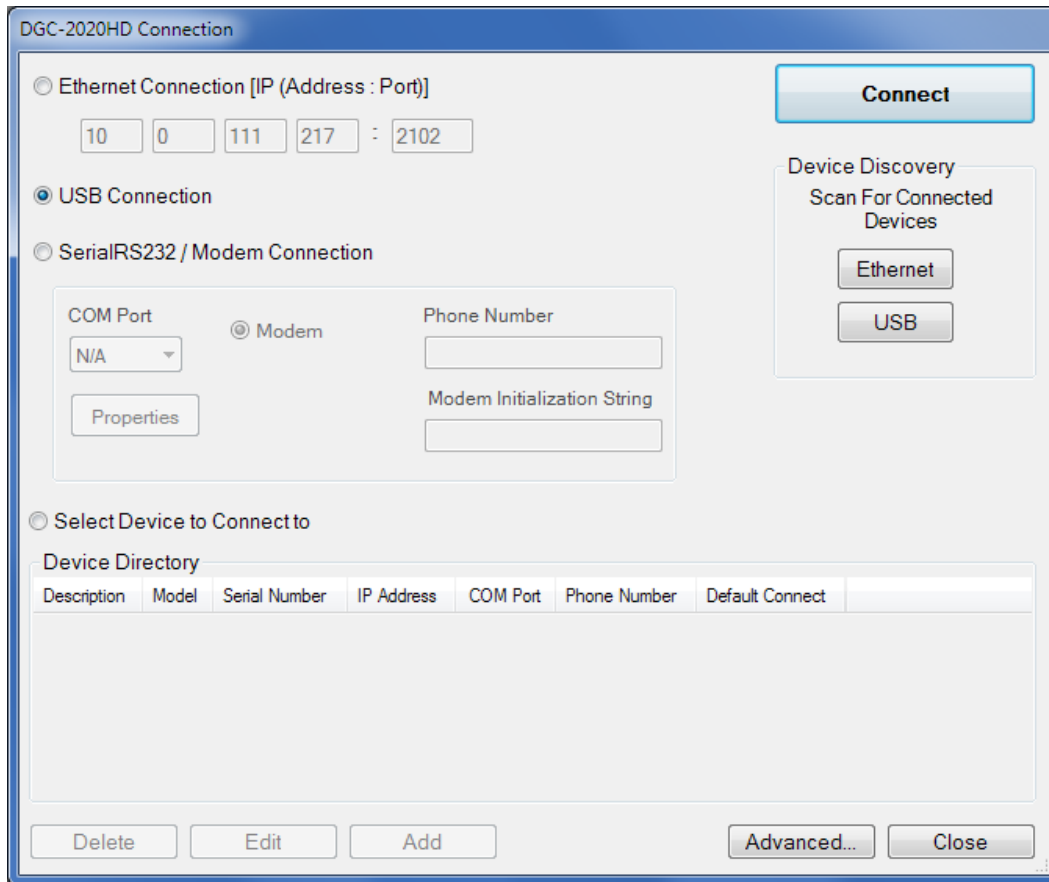

Figure 5-4. DGC-2020HD Connection Dialog

If you receive an “Unable to Connect to Device” error message, verify that communications are configured properly. Download all settings and logic from the DGC-2020HD by selecting Download Settings and Logic from the Communication pull-down menu. BESTCOMSP*lus* will read all settings and logic from the DGC-2020HD and load them into BESTCOMSP*lus* memory. See Figure 5-5.

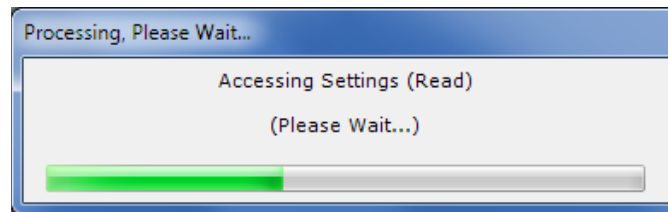

Figure 5-5. Processing, Please Wait...

Ethernet Connection

Ethernet ports provide communications between the DGC-2020HD and a PC via BESTCOMSP*lus* or other DGC-2020HDs in a network. An Ethernet connection to a PC running BESTCOMSP*lus* provides remote metering, setting, annunciation, and control of the DGC-2020HD. Ethernet communication between DGC-2020HDs allows for real power (kW) and reactive power (kvar) load sharing.

Note

The PC running BESTCOMSP*lus* software must be configured correctly to communicate with the DGC-2020HD. It must have an IP address in the same subnet range as the DGC-2020HD if operating on a private local network. Otherwise, the PC must have a valid IP address with access to the internet and the DGC-2020HD must be connected to a properly configured router. The network settings of the PC depend on the operating system installed. Refer to the operating system manual for instructions. On most Microsoft® Windows®-based PCs, the network settings can be accessed through the Network Connections icon located inside the Control Panel.

Ethernet Setup

1. To configure Ethernet through BESTCOMSP*lus*, first establish a connection via USB, Modem, or Ethernet (if already configured).
2. Click Communication in the top menu, mouse-over Configure, and click Ethernet.
3. The Configure Ethernet Port screen appears. Settings on this screen differ depending on the Ethernet port style of the connected DGC-2020HD. Figure 5-6 illustrates the settings provided for dual copper Ethernet ports (style xxxxDxxxx). Figure 5-7 illustrates the settings for a fiber optic Ethernet port (style xxxxFxxxx).

The screenshot shows the 'Ethernet Configuration View' window. At the top, there are three buttons: 'Download', 'Send to Device', and 'Close'. Below these, there is a checkbox for 'Redundant Ethernet' which is unchecked. The window is divided into two columns for 'Ethernet 1' and 'Ethernet 2'. Each column has three input fields for IP Address, Default Gateway, and Subnet Mask, and a checkbox for 'Use DHCP'. For Ethernet 1, the IP Address is 10.0.1.10, the Default Gateway is 10.0.1.1, and the Subnet Mask is 255.255.255.0. For Ethernet 2, the IP Address is 0.0.0.0, the Default Gateway is 0.0.0.0, and the Subnet Mask is 255.255.255.255. Both 'Use DHCP' checkboxes are unchecked.

Figure 5-6. Dual Copper Ethernet Port Configuration

Figure 5-7. Fiber Optic Ethernet Port Configuration

4. The values for these options should be obtained from the site administrator if the DGC-2020HD is intended to share the network with other devices.
5. If the DGC-2020HD is operating on an islanded network, the IP address may be chosen from one of the following ranges as listed in IETF publication RFC 1918, *Address Allocation for Private Networks*.
 - 10.0.0.0 to 10.255.255.255
 - 172.16.0.0 to 172.31.255.255
 - 192.168.0.0 to 192.168.255.255
6. If the DGC-2020HD is operating on an isolated network, the Subnet Mask can be left at 0.0.0.0 and the Default Gateway can be chosen as any valid IP address from the same range as the DGC-2020HD IP address.
7. Click the Send to Device button located on the Configure Ethernet Port screen. A confirmation popup is displayed notifying the user that the DGC-2020HD will reboot after settings are sent. Click the Yes button to allow settings to be sent. After the unit has rebooted and the power-up sequence is complete, the DGC-2020HD is ready to be used on a network.
8. If desired, DGC-2020HD settings can be verified by selecting Download Settings and Logic from the Communication pull-down menu. Active settings are downloaded from the DGC-2020HD. Verify that the downloaded settings match the previously sent settings.

Establishing Ethernet Communication

The DGC-2020HD Connection screen is found under the Communication pull-down menu, New Connection, DGC-2020HD or by clicking the Connect button located on the lower menu bar (Figure 5-8).

Click the Scan for Connected Devices, Ethernet button (1). The Device Discovery screen appears with a list of detected DGC-2020HD controllers on the network. Select the desired unit (2) and click Connect (3) to connect to the unit. If an “Unable to Connect to Device” error message is received, verify that communications are configured properly.

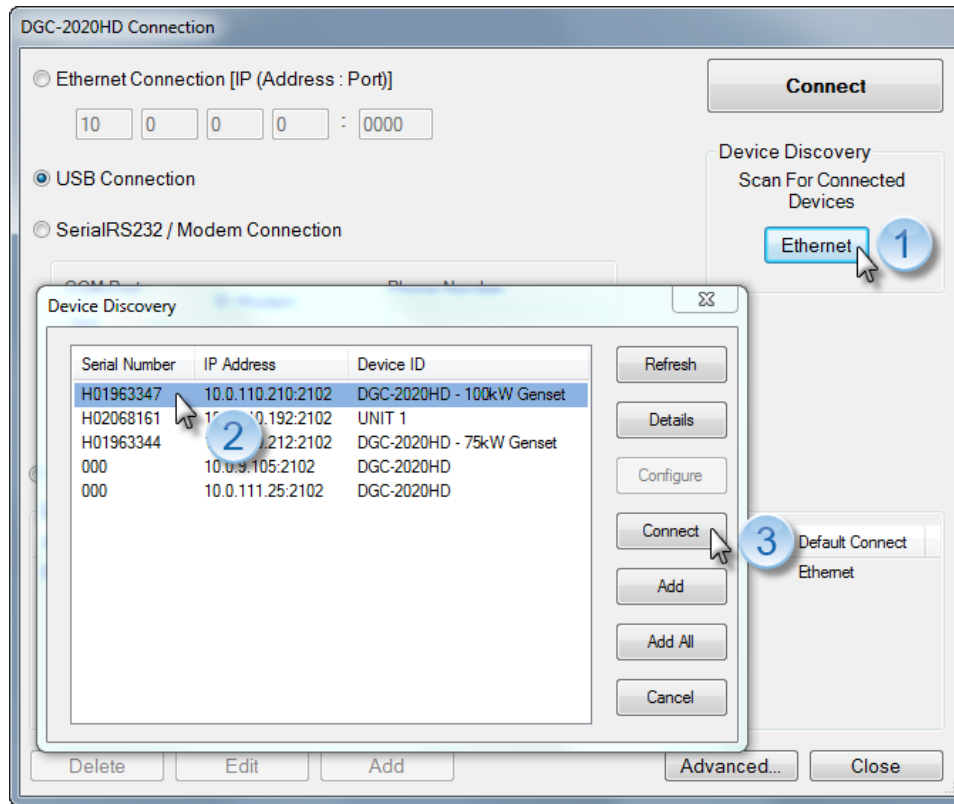

Figure 5-8. DGC-2020HD Connection and Device Discovery Screens

CAN Bus J1939 Setup

These terminals provide communication using the SAE J1939 protocol or the *mtu* protocol and provide high-speed communication between the DGC-2020HD and an ECU on an electronically controlled engine. Connections between the ECU and DGC-2020HD should be made with twisted-pair, shielded cable. CAN interface terminals are listed in Table 5-2.

Figure 5-9 illustrates typical DGC-2020HD CAN connections.

Table 5-2. CAN Interface Terminals

Terminals	Description
51 (CAN 1 L)	CAN 1 low connection
52 (CAN 1 H)	CAN 1 high connection
53 (SHIELD)	CAN drain connection
54 (CAN 2 L)	CAN 2 low connection
55 (CAN 2 H)	CAN 2 high connection

Caution

When CAN is enabled, the DGC-2020HD ignores the following sender inputs: oil pressure, coolant temperature, and magnetic pickup.

Caution

DGC-2020HD controllers have two separate CAN ports: CAN 1 and CAN 2. CAN 1 consists of terminals 51 (CAN L), 52 (CAN H), and 53 (SHIELD) and communicates solely with Basler Electric expansion modules. This port accommodates one VRM-2020, up to four CEM-2020s and up to four AEM-2020s simultaneously. CAN 2 consists of terminals 54 (CAN L), 55 (CAN H), and 53 (SHIELD) and is dedicated for communication with Engine Control Units (ECU) and related devices.

Note

1. If the DGC-2020HD is providing one end of the J1939 bus, a 120 Ω , ½ watt terminating resistor should be installed across terminals 51 (CAN1L) and 52 (CAN1H) or 54 (CAN2L) and 55 (CAN2H)
2. If the DGC-2020HD is not providing one end of the J1939 bus, the stub connecting the DGC-2020HD to the bus should not exceed 914 mm (3 ft) in length.
3. The maximum bus length, not including stubs, is 40 m (131 ft).
4. The J1939 drain (shield) should be grounded at one point only. If grounded elsewhere, do not connect the drain to the DGC-2020HD.
5. It is recommended to upgrade the firmware in all AEM-2020s and CEM-2020s that share a CAN bus network with a VRM-2020.
Upgrade CEM-2020s to firmware version 1.01.05 or later.
Upgrade AEM-2020s to firmware version 1.00.06 or later.

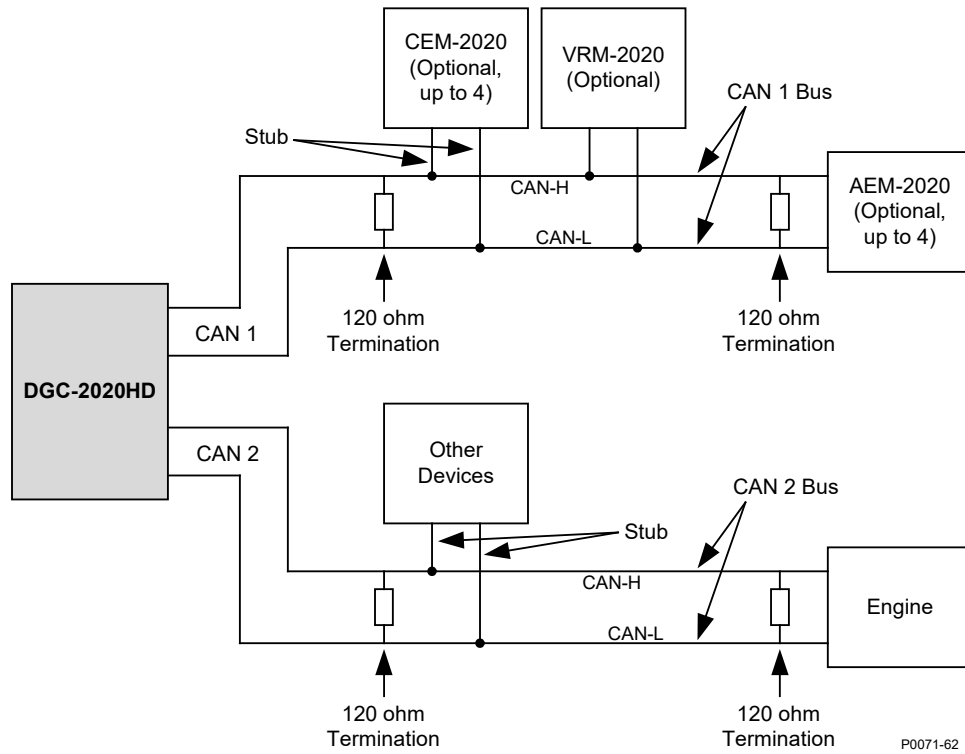

Figure 5-9. CAN Interface with DGC-2020HD Providing One End of the Bus

A DGC-2020HD operating on a CAN Bus network is identified by a unique address number. The CAN Bus address is set internally by the DGC-2020HD when certain types of ECUs are selected on the ECU Setup screen, and in this case, the user-entered value does not apply. See Table 5-3.

Table 5-3. CAN Bus Address per ECU Type

ECU Type	CAN Bus Address
Standard	User-selectable
Volvo Penta	17
mtu MDEC	6
mtu ADEC	1
mtu ECU7/ECU8	6
GM/Doosan	User-selectable
Cummins	220
mtu Smart Connect	234
Scania	39
John Deere	User-selectable
Isuzu	User-selectable
Deutz	User-selectable



6 • Configuration

The DGC-2020HD must be properly configured for operation with a specific application prior to running. An incomplete list of basic settings to consider when configuring the DGC-2020HD is provided below with their locations in BESTCOMS*Plus* and the front panel. Ensure that all settings required for your application are configured in accordance with the generator/engine manufacturer(s) recommendations, authority having jurisdiction, and customer requirements. For detailed information on all settings, refer to the *Configuration* manual.

Basic Settings

For front panel interface components, refer to the *Controls and Indicators* chapter. For BESTCOMS*Plus* interface components, refer to the *BESTCOMSPlus Software* chapter.

System Settings

BESTCOMSPlus Navigation Path: Settings Explorer, System Parameters, System Settings

Front Panel Navigation Path: Settings > System Parameters > System Settings

CAN Bus Setup

BESTCOMSPlus® Navigation Path: Settings Explorer, Communications, CAN Bus, CAN Bus Setup

Front Panel Navigation Path: Settings > Communication > CAN Bus 1 (I/O) Setup and CAN Bus 2 (ECU) Setup

ECU Setup

BESTCOMSPlus® Navigation Path: Settings Explorer, Communications, CAN Bus, ECU Setup

Front Panel Navigation Path: Settings > Communication > CAN Bus 2 (ECU) Setup > ECU Setup

Rated Data

BESTCOMSPlus Navigation Paths:

Settings Explorer, System Parameters, Rated Data, Generator Rated Data

Settings Explorer, System Parameters, Rated Data, Bus 1 Rated Data

Settings Explorer, System Parameters, Rated Data, Bus 2 Rated Data (optional)

Front Panel Navigation Paths:

Settings > System Parameters > Rated Data, Gen

Settings > System Parameters > Rated Data, Bus 1

Settings > System Parameters > Rated Data, Bus 2 (optional)

Remote Module Setup

BESTCOMSPlus Navigation Path: Settings Explorer, System Parameters, Remote Module Setup

Front Panel Navigation Path: Settings > System Settings > Remote Module Setup

Crank Settings

BESTCOMSPlus Navigation Path: Settings Explorer, System Parameters, Crank Settings

Front Panel Navigation Path: Settings > System Parameters > Crank Settings

Relay Control Settings

BESTCOMSPlus Navigation Path: Settings Explorer, System Parameters, Relay Control

Front Panel Navigation Path: Settings > System Parameters > Relay Control

Engine Sender Characteristic Curves Setup: Fuel, Temperature, and Oil

BESTCOMSPlus® Navigation Path: Settings Explorer, Programmable Senders

Front Panel Navigation Path: Not available through the front panel

Contact Inputs

BESTCOMSPlus Navigation Path: Settings Explorer, Programmable Inputs, Contact Inputs

Front Panel Navigation Path: Settings > Programmable Inputs > Contact Inputs

Programmable Functions

BESTCOMSPlus Navigation Path: Settings Explorer, Programmable Inputs, Programmable Functions

Front Panel Navigation Path: Settings > Programmable Inputs > Programmable Functions

Programmable Output Configuration

BESTCOMSPlus® Navigation Path: Settings Explorer, Programmable Outputs, Contact Outputs

Front Panel Navigation Path: Settings Explorer > Programmable Outputs > Contact Outputs

Configurable Elements

BESTCOMSPlus® Navigation Path: Settings Explorer, Programmable Outputs, Configurable Elements

Front Panel Navigation Path: Settings Explorer > Programmable Outputs > Configurable Elements

System Breaker Configuration Settings

BESTCOMSPlus® Navigation Path: Settings Explorer, System Parameters, System Settings

Front Panel Navigation Path: Settings Explorer > System Parameters > System Settings

Generator Breaker Settings

BESTCOMSPlus® Navigation Path: Settings Explorer, Breaker Management, Breaker Hardware, Gen Breaker

Front Panel Navigation Path: Settings Explorer > Breaker Management > Breaker Hardware > Gen Breaker

Mains Breaker Settings

BESTCOMSPlus® Navigation Path: Settings Explorer, Breaker Management, Breaker Hardware, Mains Breaker

Front Panel Navigation Path: Settings Explorer > Breaker Management > Breaker Hardware > Mains Breaker

AVR Bias Control Settings

BESTCOMSPlus® Navigation Path: Settings Explorer, Bias Control Settings, AVR Bias Control Settings

Front Panel Navigation Path: Settings > Bias Control > AVR Bias Control

Governor Bias Control Settings

BESTCOMSPlus Navigation Path: Settings Explorer, Bias Control Settings, Governor Bias Control Settings

Front Panel Navigation Path: Settings > Bias Control > Gov Bias Control

AVR Output

BESTCOMSPlus Navigation Path: Settings Explorer, Multigen Management, AVR Output

Front Panel Navigation Path: Settings > Multigen Management > AVR Output

Governor Output

BESTCOMSPlus Navigation Path: Settings Explorer, Multigen Management, Governor Output
Front Panel Navigation Path: Settings > Multigen Management > Gov Output

Generator Protection

BESTCOMSPlus Navigation Path: Settings Explorer, Generator Protection, (Select parameter)
Front Panel Navigation Path: Settings Explorer > Protection > Settings Group x (where x = 0 to 3) > (Select Protection) > (Select which element to set)

Saving Settings

Front Panel

When settings are configured through the front panel interface, they are automatically saved.

BESTCOMSPlus®

After the desired settings are configured in BESTCOMSPlus, the settings must be uploaded to a connected DGC-2020HD. Refer to the following procedure to upload settings via BESTCOMSPlus.

1. Ensure that communication between a PC running BESTCOMSPlus and the DGC-2020HD is established.
2. In the Upper Menu Bar, Click Communications > Upload Settings to Device
3. Enter the username and password when prompted. The default username is "A" and default password is "A". See Figure 6-1.
4. Press Enter or click Log In and the settings are uploaded to the connected DGC-2020HD.

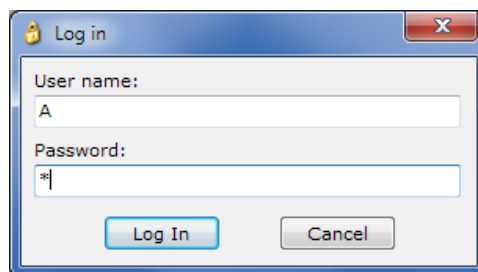

Figure 6-1. Log In Screen



7 • BESTlogic™ Plus

BESTlogicPlus Programmable Logic is a programming method used for managing the input, output, protection, control, monitoring, and reporting capabilities of Basler Electric's DGC-2020HD Digital Genset Controller.

BESTlogic™ Plus Composition

There are three main groups of objects used for programming BESTlogicPlus. These groups are I/O, Components, and Elements. For details on how these objects are used to program BESTlogicPlus, see the paragraphs on *Programming BESTlogicPlus* later in this chapter.

Logic Schemes

A logic scheme is a group of logic variables written in equation form that defines the operation of a DGC-2020HD Digital Genset Controller. Each logic scheme is given a unique name. This gives you the ability to select a specific scheme and be confident that the selected scheme is in operation. The default active logic scheme is configured for typical control applications. Only one logic scheme can be active at a time.

In most applications, preprogrammed logic schemes eliminate the need for custom programming. Preprogrammed logic schemes may provide more inputs, outputs, or features than are needed for a particular application. This is because a preprogrammed scheme is designed for a large number of applications with no special programming required. Unneeded logic block outputs may be left open to disable a function or a function block can be disabled through operating settings.

When a custom logic scheme is required, programming time is reduced by modifying the default logic scheme.

The Active Logic Scheme

Digital Genset Controllers must have an active logic scheme in order to function. All Basler Electric DGC-2020HD units are delivered with a default, active logic scheme pre-loaded in memory. If the function block configuration and output logic of the default logic scheme meets the requirements of your application, then only the operating settings (power system parameters and threshold settings) need to be adjusted before placing the DGC-2020HD in service.

Sending a Logic Scheme to the DGC-2020HD

To send logic to the DGC-2020HD, it must be connected to a computer through a communications port. Once the necessary connections are made, settings can be uploaded to the DGC-2020HD by selecting Upload Settings and Logic to Device or Upload Logic to Device on the Communication pull-down menu.

Caution

Always remove the DGC-2020HD from service prior to changing or modifying the active logic scheme. Attempting to modify a logic scheme while the DGC-2020HD is in service could generate unexpected or unwanted outputs.

Modifying a logic scheme in BESTCOMSPlus does not automatically make that scheme active in the DGC-2020HD. The modified scheme must be uploaded into the DGC-2020HD.

Operational settings are not included in the default logic scheme. Each element, function, alarm, etc. will have to be enabled and programmed separately using the Settings Explorer in BESTCOMSPlus.

Retrieving a Logic Scheme from the DGC-2020HD

To retrieve logic from the DGC-2020HD, it must be connected to a computer through a communications port. Once the necessary connections are made, logic can be downloaded from the DGC-2020HD by selecting Download Settings and Logic from Device on the Communication pull-down menu.

Programming BESTlogic™Plus

Use BESTCOMSPPlus to program BESTlogicPlus. Using BESTCOMSPPlus is analogous to physically attaching wire between discrete DGC-2020HD terminals. To program BESTlogicPlus, use the Settings Explorer within BESTCOMSPPlus to open the BESTlogicPlus Programmable Logic tree branch as shown in Figure 7-1.

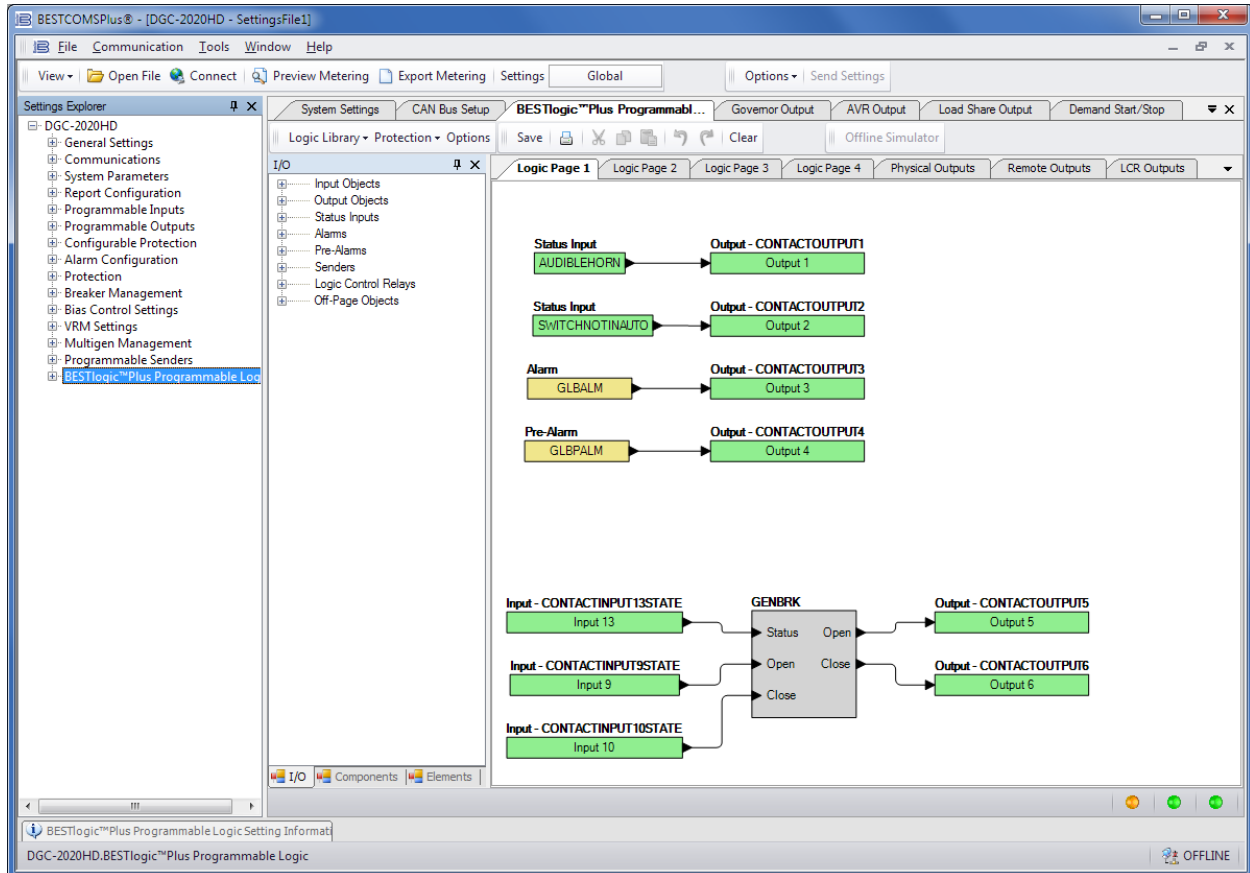

Figure 7-1. Settings Explorer, BESTlogicPlus Programmable Logic Screen

The drag and drop method is used to connect a variable or series of variables to the logic inputs, outputs, components, and elements. To draw a wire/link from port to port (triangles), click the left mouse button on a port, pull the wire onto another port, and release the left mouse button. A red port indicates that a connection to the port is required or missing. A black port indicates that a connection to the port is not required. Drawing wires/links from input to input or output to output is not allowed. Only one wire/link can be connected to any one output. If the proximity of the endpoint of the wire/link is not exact, it may attach to an unintended port.

If an object or element is disabled, it will have a yellow X on it. To enable the element, navigate to the settings page for that element. A red X indicates that an object or element is not available per the style number of the DGC-2020HD.







The view of Logic Page 1 through 4, Physical Outputs, Remote Outputs, and LCR Outputs can be automatically arranged by clicking the right mouse button on the window and selecting Auto-Layout.

The following must be met before BESTCOMSPi+ will allow logic to be uploaded to the DGC-2020HD:

- A minimum of two inputs and a maximum of 32 inputs on any multi-port (AND, OR, NAND, NOR, XOR, and XNOR) gate.
- A maximum of 32 logic levels for any particular path. A path being an input block or an output side of an element block through gates to an output block or an input side of an element block. This is to include any OR gates on the Physical Output or Remote Output tab/pages, but not the matched pairs of Physical Output blocks or Remote Output blocks.
- A maximum of 256 gates per logic level with a maximum of 256 gates allowed per diagram. All output blocks and input sides of element blocks are at the maximum logic level of the diagram. All gates are pushed forward/upwards in logic levels and buffered to reach the final output block or element block if needed.

Three status indicators are located in the lower right corner of the BESTlogicPi+ window. These indicators show the Logic Save Status, Logic Diagram Status, and Logic Layer Status. Table 7-1 defines the colors for each indicator.

Table 7-1. Status Indicators

Indicator	Color	Definition
Logic Save Status (Left Indicator)	 Amber	Logic has changed since last save.
	 Green	Logic has NOT changed since last save.
Logic Diagram Status (Center Indicator)	 Red	Requirements NOT met as listed above.
	 Green	Requirements met as listed above.
Logic Layer Status (Right Indicator)	 Red	Requirements NOT met as listed above.
	 Green	Requirements met as listed above.

Offline Logic Simulator

The offline logic simulator allows you to change the state of various logic elements to illustrate how that state travels through the system. Before running the logic simulator, you must click the Save button on the BESTlogicPi+ toolbar to save the logic to memory. Changes to the logic (other than changing the state) are disabled when the simulator is enabled. Colors are selected by clicking the Options button on the BESTlogicPi+ toolbar. By default, Logic 0 is red and Logic 1 is green. Using your mouse, double-click on a logic element to change its state.

An example of the offline logic simulator is shown in Figure 7-2. Output 1 is Logic 0 (red) when Virtual Switch 1 is Logic 0 (red) and Fixed 1 is Logic 1 (green).

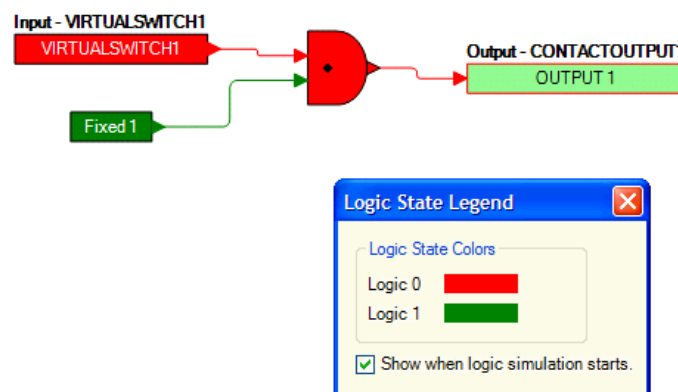

Figure 7-2. Offline Logic Simulator Example

BESTlogic™ Plus Examples

Example 1 - GENBRK Logic Block Connections

Figure 7-3 illustrates the GENBRK logic block, three input logic blocks, and two output logic blocks. Output 3 is active while the GENBRK is sending an “open breaker” command and Output 4 is active while the GENBRK is sending the “close breaker” command.

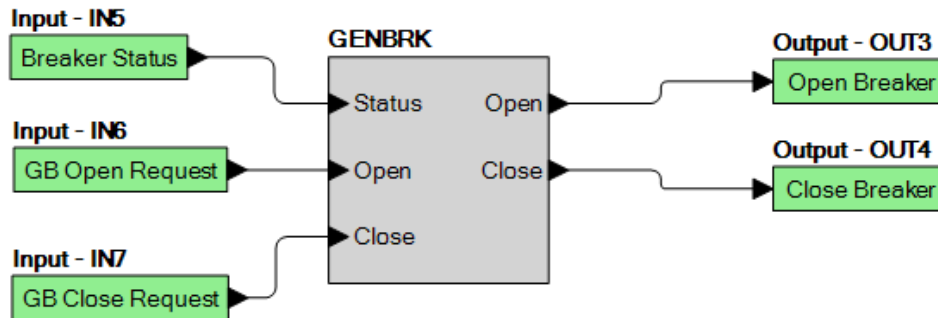

Figure 7-3. Example 1 – GENBRK Logic Block Connections

Example 2 - AND Gate Connections

Figure 7-4 illustrates a typical AND gate connection. In this example, Output 11 will become active when the Low Fuel alarm AND the Low Oil Pressure alarm are true.

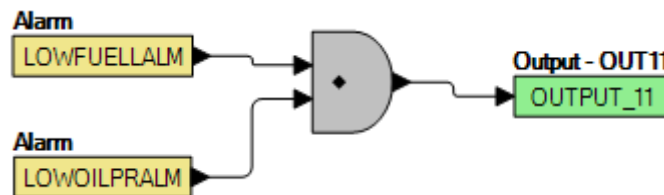

Figure 7-4. Example 2 – AND Gate Connections

Example 3 - Multiple Logic Connections

In this example, there are two comment boxes, which may be placed on the logic diagram. Double-click a comment box to modify the inside text. Output 3 becomes true when the 27TRIP is true. Output 1 becomes true when the High Coolant Temp is true. Output 2 becomes true when the DGC-2020HD is in RUN mode (RUN Mode true). Refer to Figure 7-5.

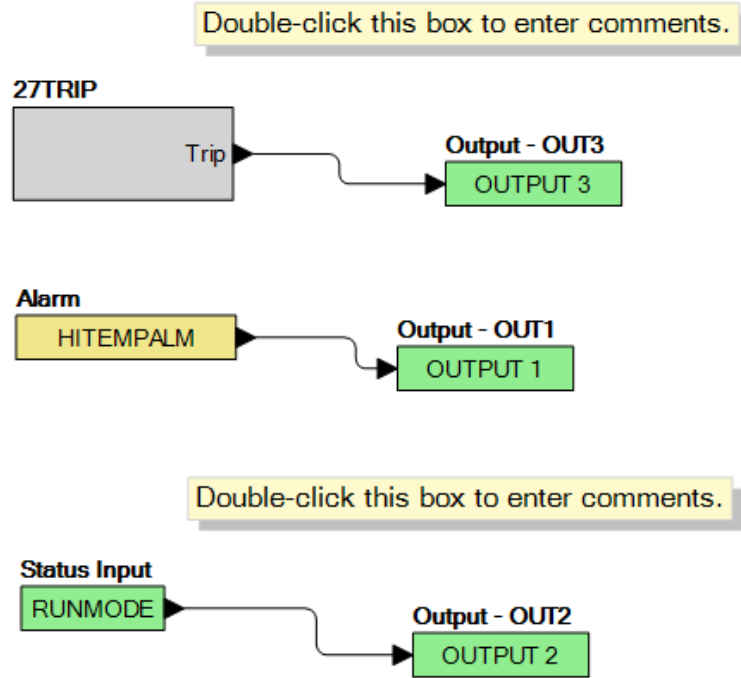

Figure 7-5. Example 3 – Multiple Logic Connections



8 • Controls and Indicators

DGC-2020HD controls and indicators are illustrated in Figure 8-1. Lettered locators in Figure 8-1 correspond to the control and indicator descriptions of Table 8-1.

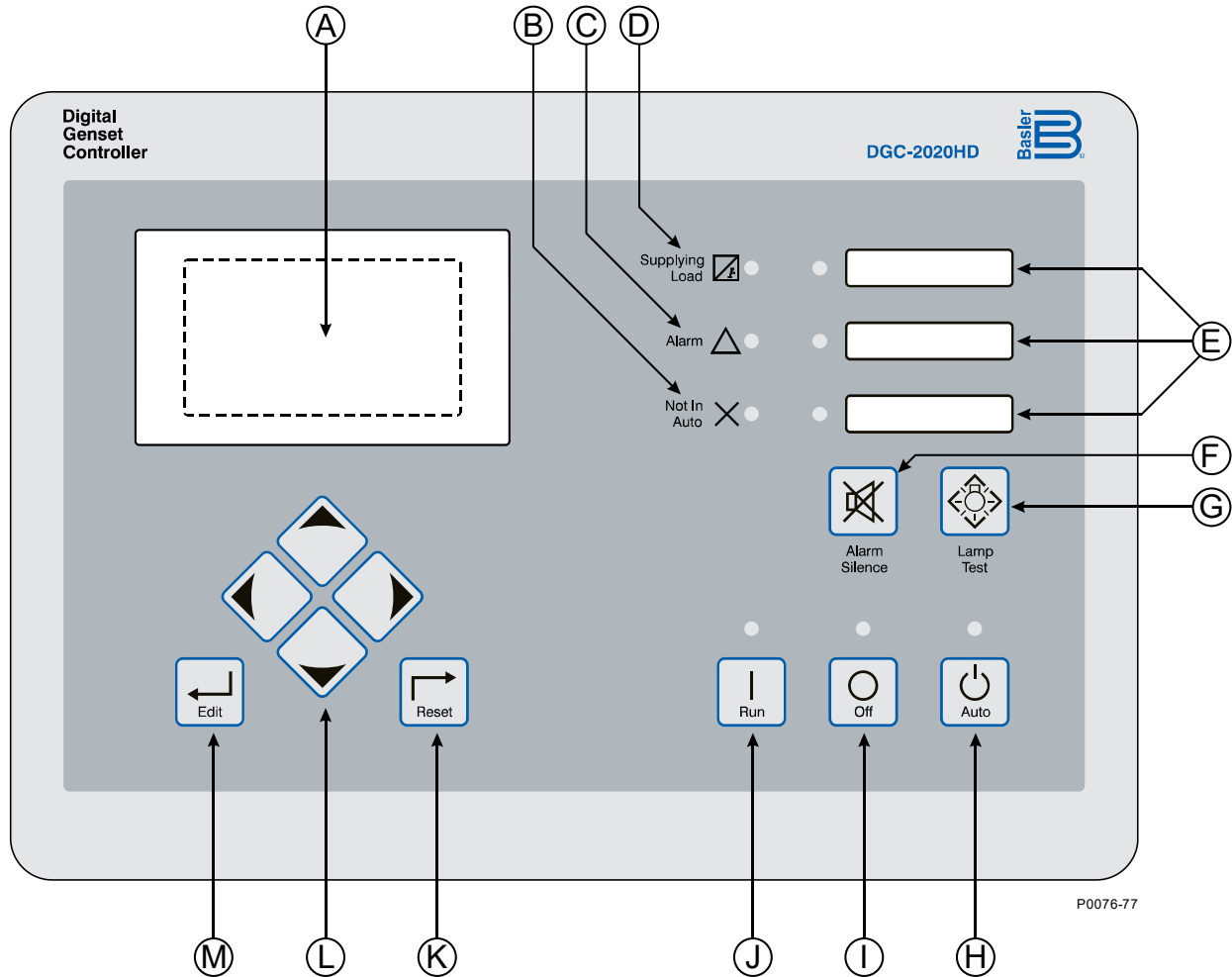

Figure 8-1. Front-Panel Controls and Indicators

Table 8-1. Front-Panel Control and Indicator Descriptions

Locator	Description
A	Depending on the style selected, the DGC-2020HD comes equipped with either a default monochrome LCD or an optional color touch screen LCD. <i>Default LCD (style xNxxxxxx).</i> The backlit, 64 by 128 pixel LCD serves as the local information source for metering, alarms, pre-alarms, and protective functions. Display operation is maintained down to -40°F (-40°C). <i>Color Touch Screen LCD (style xTxxxxxx).</i> The backlit, 272 by 480 pixel color LCD serves as the local information source for metering, alarms, pre-alarms, and protective functions. Touch screen capability provides convenient navigation through metering and settings. Display operation is maintained down to -4°F (-20°C).
B	<i>Not in Auto Indicator.</i> This red LED lights when the DGC-2020HD is not operating in Auto mode.
C	<i>Alarm Indicator.</i> This red LED lights continuously during alarm conditions and flashes during pre-alarm conditions.

Locator	Description
D	<i>Supplying Load Indicator.</i> This green LED lights when the generator current is greater than emergency power supply (EPS) threshold current.
E	<i>Programmable Indicators.</i> These red LEDs light when the corresponding logic element is set true. Logic element PROGLED 1 controls the upper LED, PROGLED2 controls the middle LED, and PROGLED3 controls the lower LED. A card is provided for labeling the programmable indicators. See the <i>Controls and Indicators</i> chapter in the <i>Operation</i> manual.
F	<i>Alarm Silence Pushbutton.</i> Pressing this button opens the relay output programmed as the horn output.
G	<i>Lamp Test Pushbutton.</i> Pressing this button tests the DGC-2020HD indicators by exercising all LCD pixels and lighting all LEDs.
H	<i>Auto Pushbutton and Mode Indicator.</i> Pressing the Auto button places the DGC-2020HD in Auto mode. The green Auto mode LED lights when Auto mode is active.
I	<i>Off Pushbutton and Mode Indicator.</i> Pressing this button places the DGC-2020HD in Off mode. The red Off mode LED lights when the DGC-2020HD is in Off mode. This button also resets the Breaker Management Pre-Alarms and all <i>mtu</i> ECU Alarms.
J	<i>Run Pushbutton and Mode Indicator.</i> Pressing this button places the DGC-2020HD in Run mode. The green Run mode LED lights when Run mode is active.
K	<i>Reset Pushbutton.</i> This button is pressed to cancel a settings editing session and discard any settings changes. When pressed momentarily, this button resets the Breaker Management Pre-Alarms and all <i>mtu</i> ECU Alarms. This button is also used to reset the Maintenance Interval when pressed for 10 seconds while viewing the front-panel Overview screen.
L	<p><i>Arrow Pushbuttons.</i> These four buttons are used to navigate through the front-panel display menus and modify settings.</p> <p>The left and right arrow buttons are used to navigate through the menu levels. The right arrow button is pressed to move downward through the menu levels and the left arrow button is pressed to move upward through the menu levels.</p> <p>Within a level, the up and down arrow buttons are used to move among items within the menu level. Pressing the down arrow button moves to items lower in the list. Pressing the up arrow button moves to items higher in the list.</p> <p>During a settings editing session, the up and down arrow buttons are used to raise and lower the value of the selected setting. The right and left arrow buttons move to different digits.</p>
M	<i>Edit Pushbutton.</i> Pressing this button starts an editing session and enables changes to DGC-2020HD settings. At the conclusion of an editing session, the Edit pushbutton is pressed again to save the setting changes.

Power Indicator

A green LED, located on the rear of the DGC-2020HD, indicates that the unit is powered.

DIN Rail and Rear Panel Mounted Units

DGC-2020HD units with either the DIN Rail mount option (style xRxxxxxx) or the Rear Panel mount option (style xPxxxxxx) have no HMI. The rear of the DGC-2020HD faces outward for convenient access to terminals and connections.

Touch Screen Operation

DGC-2020HDs with the color touch screen display option (style xTxxxxxx) provide a convenient means of navigating through menus and settings by allowing direct interaction with what is displayed. All operations that can be performed using the touch screen can also be performed using the pushbuttons.

However, critical settings must be initiated using the pushbuttons to prevent accidental operation with the touch screen.

Touch screen controls are illustrated in Figure 8-2. Lettered locators in Figure 8-2 correspond to the control descriptions of Table 8-2.

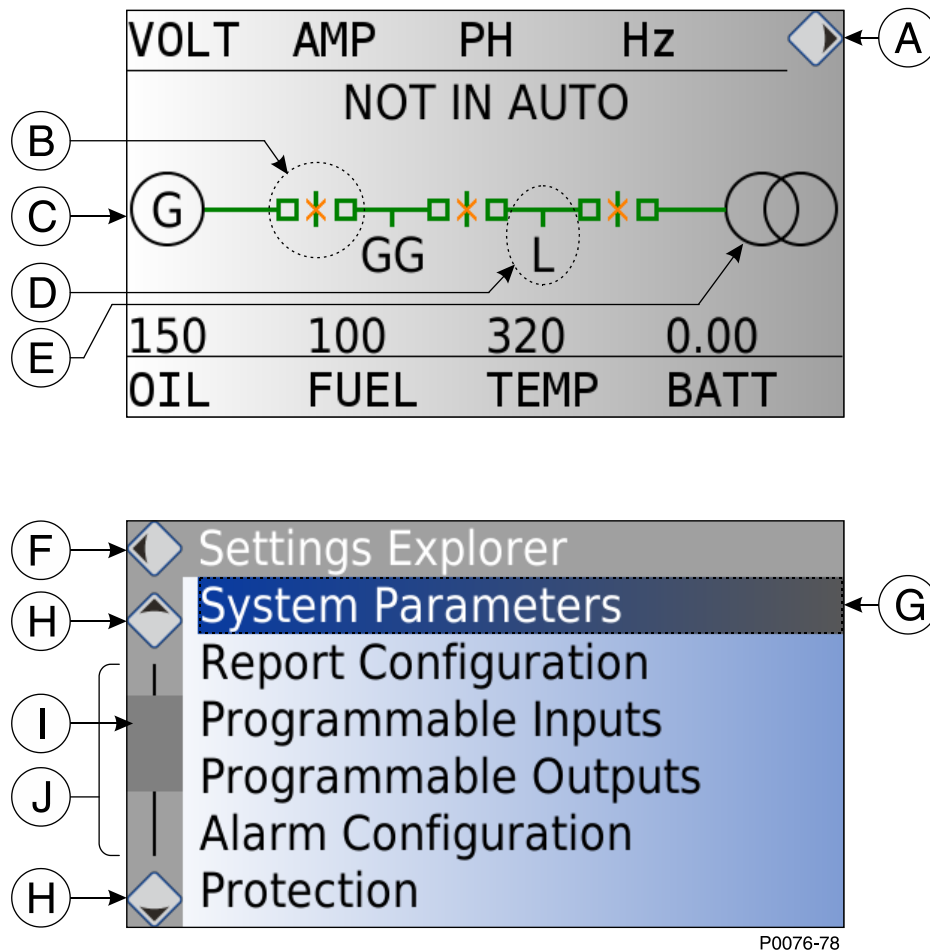

Figure 8-2. Touch Screen Controls

Table 8-2. Touch Screen Control Descriptions

Locator	Description
A	<i>Enter button.</i> This button, found only on the overview screen, enters the Main Menu.
B	Breaker control. To send an open or close request to a breaker in the system, follow these steps: 1. Touch the corresponding breaker in the diagram. 2. Press the up or down arrow keys to scroll the options. 3. Press Edit to send the selected breaker command request.
C	<i>Generator metering.</i> Touch the generator in the diagram to view metered voltage, current, frequency, kW, kvar, and power factor values of the local generator.
D	<i>Bus metering.</i> Touch a bus in the diagram to view metered voltage, current, frequency, kW, kvar, and power factor values of the corresponding bus in the system.
E	<i>Mains metering.</i> Touch the mains in the diagram to view metered voltage, current, frequency, kW, kvar, and power factor values of the mains bus.
F	<i>Back button.</i> Touch the Back button to return to the previous menu.

Locator	Description
G	<i>Menu Option.</i> Touch a menu option to enter its submenu. If the option is an editable value, adjust it using the arrow pushbuttons, and press the Edit pushbutton to accept the change.
H	<i>Up and Down Arrows.</i> Touching the Up arrow scrolls the menu options toward the top of the list and touching the Down arrow scrolls the menu options toward the bottom of the list.
I	<i>Scroll box.</i> This represents the range of options in the list that are currently being displayed. The scroll box has no touch commands.
J	<i>Scroll bar.</i> Scroll bars represent the entire list of options for the current menu screen. Touching a point in the white portion of the scroll bar will display the menu options at that position in the list.

Disabling the Touch Screen

Touch screen controls may be disabled with a setting in *BESTCOMSPlus*, front-panel pushbuttons, or automatically. To disable touch screen controls using the front-panel pushbuttons, press and hold Lamp Test then press Edit. Touch screen controls are disabled automatically if the touch screen detects a press for longer than 60 seconds.



Highland, Illinois USA
Tel: +1 618.654.2341
Fax: +1 618.654.2351
email: info@basler.com

Suzhou, P.R. China
Tel: +86 512.8227.2888
Fax: +86 512.8227.2887
email: chinainfo@basler.com



Highland, Illinois USA
Tel: +1 618.654.2341
Fax: +1 618.644.2351
email: info@basler.com

Suzhou, P.R. China
Tel: +86 512.8227.2888
Fax: +86 512.8227.2887
email: chinainfo@basler.com