

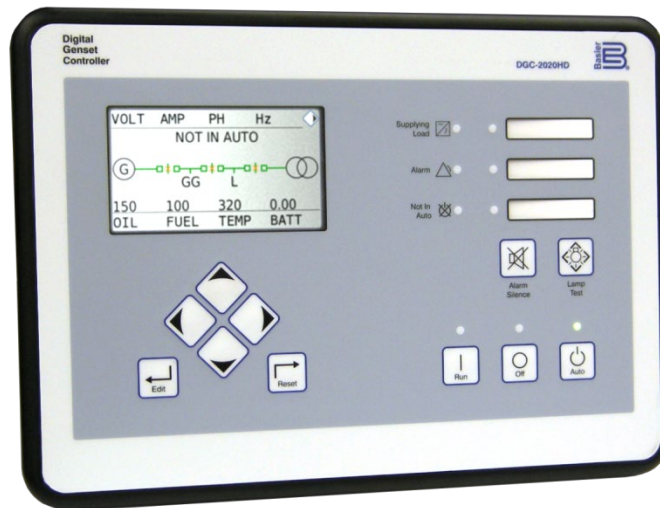



DGC-2020HD

Digital Genset Controller

Accessories Instruction Manual



 **WARNING:** California's Proposition 65 requires special warnings for products that may contain chemicals known to the state of California to cause cancer, birth defects, or other reproductive harm. Please note that by posting this Proposition 65 warning, we are notifying you that one or more of the Proposition 65 listed chemicals may be present in products we sell to you. For more information about the specific chemicals found in this product, please visit <https://www.basler.com/Prop65>.

Preface

This instruction manual provides information about the accessories for the DGC-2020HD Digital Genset Controller. To accomplish this, the following information is provided:

- AEM-2020 (Analog Expansion Module)
- CEM-2020 (Contact Expansion Module)
- VRM-2020 (Voltage Regulation Module)

Conventions Used in this Manual

Important safety and procedural information is emphasized and presented in this manual through Warning, Caution, and Note boxes. Each type is illustrated and defined as follows.

Warning!

Warning boxes call attention to conditions or actions that may cause personal injury or death.

Caution

Caution boxes call attention to operating conditions that may lead to equipment or property damage.

Note

Note boxes emphasize important information pertaining to Digital Genset Controller installation or operation.

DGC-2020HD Instruction Manual Catalog

Available instruction manuals for the DGC-2020HD are listed in Table 1.

Table 1. Instruction Manuals

Part Number	Description
9469300993	Quick Start
9469300994	Installation
9469300995	Configuration
9469300996	Operation
9469300997	Accessories (this manual)
9469300998	Modbus® Protocol



12570 State Route 143
Highland IL 62249-1074 USA

www.basler.com

info@basler.com

Tel: +1 618.654.2341

Fax: +1 618.654.2351

© 2024 by Basler Electric

All rights reserved

First printing: October 2016

Warning!

READ THIS MANUAL. Read this manual before installing, operating, or maintaining the DGC-2020HD. Note all warnings, cautions, and notes in this manual as well as on the product. Keep this manual with the product for reference. Only qualified personnel should install, operate, or service this system. Failure to follow warning and cautionary labels may result in personal injury or property damage. Exercise caution at all times.

Caution

Installing previous versions of firmware may result in compatibility issues causing the inability to operate properly and may not have the enhancements and resolutions to issues that more recent versions provide. Basler Electric highly recommends using the latest version of firmware at all times. Using previous versions of firmware is at the user's risk and may void the warranty of the unit.

Basler Electric does not assume any responsibility to compliance or noncompliance with national code, local code, or any other applicable code. This manual serves as reference material that must be well understood prior to installation, operation, or maintenance.

For terms of service relating to this product and software, see the *Commercial Terms of Products and Services* document available at www.basler.com/terms.

This publication contains confidential information of Basler Electric Company, an Illinois corporation. It is loaned for confidential use, subject to return on request, and with the mutual understanding that it will not be used in any manner detrimental to the interests of Basler Electric Company and used strictly for the purpose intended.

It is not the intention of this manual to cover all details and variations in equipment, nor does this manual provide data for every possible contingency regarding installation or operation. The availability and design of all features and options are subject to modification without notice. Over time, improvements and revisions may be made to this publication. Before performing any of the following procedures, contact Basler Electric for the latest revision of this manual.

The English-language version of this manual serves as the only approved manual version.

This product contains, in part, open source software (software licensed in a way that ensures freedom to run, copy, distribute, study, change, and improve the software) and you are granted a license to that software under the terms of either the GNU General Public License or GNU Lesser General Public License. The licenses, at the time of sale of the product, allow you to freely copy, modify, and redistribute that software and no other statement or documentation from us, including our End User License Agreement, places any additional restrictions on what you may do with that software.

For at least three (3) years from the date of distribution of this product, a machine-readable copy of the complete corresponding source code for the version of the programs distributed to you will be sent upon request (contact information is provided above). A fee of no more than our cost of physically performing the source code distribution is charged.

The source code is distributed in the hope that it will be useful, but WITHOUT ANY REPRESENTATION or WARRANTY or even the implied warranty of MERCHANTABILITY or FITNESS FOR A PARTICULAR PURPOSE. Refer to the source code distribution for additional restrictions regarding warranty and copyrights.

For a complete copy of GNU GENERAL PUBLIC LICENSE Version 2, June 1991 or GNU LESSER GENERAL PUBLIC LICENSE Version 2.1, February 1999 refer to www.gnu.org or contact Basler Electric. You, as a Basler Electric Company customer, agree to abide by the terms and conditions of GNU GENERAL PUBLIC LICENSE Version 2, June 1991 or GNU LESSER GENERAL PUBLIC LICENSE Version 2.1, February 1999, and as such hold Basler Electric Company harmless related to any open source software incorporated in this product. Basler Electric Company disclaims any and all liability associated with the open source software and the user agrees to defend and indemnify Basler Electric Company, its directors, officers, and employees from and against any and all losses, claims, attorneys' fees, and expenses arising from the use, sharing, or redistribution of the software. Review the software website for the latest version of the software documentation.

Portions of this software are copyright © 2014 The FreeType Project (www.freetype.org). All rights reserved.

The following statement applies only to the fontconfig library:

fontconfig/COPYING

Copyright © 2000,2001,2002,2003,2004,2006,2007 Keith Packard

Copyright © 2005 Patrick Lam

Copyright © 2009 Roozbeh Pournader

Copyright © 2008,2009 Red Hat, Inc.

Copyright © 2008 Danilo Šegan

Copyright © 2012 Google, Inc.

Permission to use, copy, modify, distribute, and sell this software and its documentation for any purpose is hereby granted without fee, provided that the above copyright notice appear in all copies and that both that copyright notice and this permission notice appear in supporting documentation, and that the name of the author(s) not be used in advertising or publicity pertaining to distribution of the software without specific, written prior permission. The authors make no representations about the suitability of this software for any purpose. It is provided "as is" without express or implied warranty.

THE AUTHOR(S) DISCLAIMS ALL WARRANTIES WITH REGARD TO THIS SOFTWARE, INCLUDING ALL IMPLIED WARRANTIES OF MERCHANTABILITY AND FITNESS, IN NO EVENT SHALL THE AUTHOR(S) BE LIABLE FOR ANY SPECIAL, INDIRECT OR CONSEQUENTIAL DAMAGES OR ANY DAMAGES WHATSOEVER RESULTING FROM LOSS OF USE, DATA OR PROFITS, WHETHER IN AN ACTION OF CONTRACT, NEGLIGENCE OR OTHER TORTIOUS ACTION, ARISING OUT OF OR IN CONNECTION WITH THE USE OR PERFORMANCE OF THIS SOFTWARE.



Revision History

A historical summary of the changes made to this instruction manual is provided below. Revisions are listed in reverse chronological order.

Visit www.basler.com to download the latest hardware, firmware, and BESTCOMSP^{Plus}® revision histories.

Instruction Manual Revision History

Manual Revision and Date	Change
J, December 2024	<ul style="list-style-type: none"> Updated China RoHS table in the <i>Specifications</i> chapter
I	<ul style="list-style-type: none"> This revision letter not used.
H, October 2024	<ul style="list-style-type: none"> Added FCC Requirements to AEM-2020, CEM-2020, and VRM-2020.
G, October 2023	<ul style="list-style-type: none"> Added support for firmware version 3.08.00 and BESTCOMSP^{Plus} version 5.05.01. Removed EAC mark. Minor text edits.
F, July 2023	<ul style="list-style-type: none"> Added China RoHS for the AEM-2020, CEM-2020, and VRM-2020. Minor text edits throughout manual.
E, December 2021	<ul style="list-style-type: none"> Updated UL / CSA specs.
D, August 2021	<ul style="list-style-type: none"> Added “Installing previous firmware versions” caution box to Preface. Removed the CEM-2020’s UL recognition for use in Hazardous Locations. Updated the number of AEM and CEM modules that are supported on one CAN bus.
C, October 2019	<ul style="list-style-type: none"> Removed Rev Letter from all pages. Changed sequential numbering to sectional numbering. Moved Instruction Manual Revision History into Preface. Removed standalone Revision History chapter.
B1, April 2019	<ul style="list-style-type: none"> Updated Proposition 65 statement.
B, October 2018	<ul style="list-style-type: none"> Added California Prop 65 warnings. Added UL, Class I, Div. 2 for AEM-2020 and CEM-2020. Updated EAC certificate number for AEM-2020 and CEM-2020. Added analog current input connection diagrams for AEM-2020. Improved description of CEM-2020 output contact ratings.
A, November 2016	<ul style="list-style-type: none"> Minor text edits.
—, October 2016	<ul style="list-style-type: none"> Initial release



Contents

AEM-2020	1-1
CEM-2020	2-1
VRM-2020	3-1



1 • AEM-2020

The AEM-2020 (Analog Expansion Module) is an optional remote device that provides additional DGC-2020HD analog inputs and outputs. A CAN interface configured for 250 kbps supports the following combinations of AEM-2020, CEM-2020 and VRM-2020 modules:

- Up to six CEM-2020s, two AEM-2020s, and one VRM-2020
- Up to five CEM-2020s, three AEM-2020s, and one VRM-2020
- Up to four CEM-2020s, four AEM-2020s, and one VRM-2020

Features

AEM-2020s have the following features:

- 8 Analog Inputs
- 8 RTD Inputs
- 2 Thermocouple Inputs
- 4 Analog Outputs
- Functionality of Inputs and Outputs assigned by BESTlogic™*Plus* programmable logic
- Communications via control area network (CAN)

Specifications

Control Power

Nominal	12 or 24 Vdc
Range	8 to 32 Vdc (Withstands cranking ride-through down to 6 Vdc for 500 ms)
Maximum Consumption	5.1 W

Analog Inputs

The AEM-2020 contains eight programmable analog inputs.

Rating 0 to 20 mAdc or –10 to 10 Vdc (user-selectable)

Burden

4 to 20 mA 470 Ω maximum
 ± 10 Vdc 9.65k Ω minimum

RTD Inputs

The AEM-2020 contains eight programmable RTD inputs.

Rating 100 Ω Platinum or 10 Ω Copper (user-selectable)
 Setting Range –58 to +482°F (–50 to +250°C)
 Accuracy (10 Ω Copper) $\pm 0.044 \Omega$ at 25°C, $\pm 0.005 \Omega/^\circ\text{C}$ drift over ambient temperature
 Accuracy (100 Ω Platinum) $\pm 0.39 \Omega$ at 25°C, $\pm 0.047 \Omega/^\circ\text{C}$ drift over ambient temperature

Thermocouple Inputs

The AEM-2020 contains two thermocouple inputs.

Rating 2 K Type Thermocouples
 Setting Range 0 to 1,375°C or 0 to 2,507°F
 Display Range Ambient to 2,507°F (1,375°C)
 Accuracy $\pm 40 \mu\text{V}$ at 25°C, $\pm 5 \mu\text{V}/^\circ\text{C}$ drift over ambient temperature

Analog Outputs

The AEM-2020 contains four programmable analog outputs.

Rating 0 to 20 mA_{dc} or –10 to 10 V_{dc} (user-selectable)

CAN Interface

Differential Bus Voltage 1.5 to 3 V_{dc}

Maximum Voltage –32 to +32 V_{dc} with respect to negative battery terminal

Communication Rate 250 kb/s

Type Tests

Shock

Withstands 15 G in 3 perpendicular planes.

Vibration

Swept over the following ranges for 12 sweeps in each of three mutually perpendicular planes with each 15-minute sweep consisting of the following:

5 to 29 to 5 Hz 1.5 G peak for 5 minutes

29 to 52 to 29 Hz 0.036 in (0.914 mm) Double Amplitude for 2.5 minutes

52 to 500 to 52 Hz 5 G peak for 7.5 minutes

Ignition System

Tested in close proximity to an unshielded, unsuppressed Altronic DISN 800 ignition system.

HALT (Highly Accelerated Life Testing)

HALT is used by Basler Electric to prove that our products will provide the user with many years of reliable service. HALT subjects the device to extremes in temperature, shock, and vibration to simulate years of operation, but in a much shorter period. HALT allows Basler Electric to evaluate all possible design elements that will add to the life of this device. As an example of some of the extreme testing conditions, the AEM-2020 was subjected to temperature tests (tested over a temperature range of –80°C to +130°C), vibration tests (of 5 to 50 G at +25°C), and temperature/vibration tests (tested at 10 to 20 G over a temperature range of –60°C to +100°C). Combined temperature and vibration testing at these extremes proves that the AEM-2020 is expected to provide long-term operation in a rugged environment. Note that the vibration and temperature extremes listed in this paragraph are specific to HALT and do not reflect recommended operation levels. These operational ratings are included in this section.

Environment

Operating Temperature –40 to +158°F (–40 to +70°C)

Storage Temperature –40 to +185°F (–40 to +85°C)

Humidity Meets IEC 68-2-38.

Agency Standards and Directives

Maritime Recognition

American Bureau of Shipping (ABS) – For current certificates, see www.basler.com.

UL Approval

The AEM-2020 is a Recognized Component for the US and Canada under UL file E97035

(CCN-FTPM2/FTPM8) covered under the Standards below:

- UL 6200
- CSA C22.2 No.14-13

CE Compliance

This product complies with the requirements of the following EC Directives:

- Low Voltage Directive (LVD) 2014/35/EU
- Electromagnetic Compatibility (EMC) 2014/30/EU
- Hazardous Substances (RoHS 2) -2011/65/EU

This product conforms to the following Harmonized Standards:

- EN 50178:1997 - *Electronic Equipment for use in Power Installations*
- EN 61000-6-4:2001 - *Electromagnetic Compatibility (EMC), Generic Standards, Emission Standard for Industrial Environments*
- EN 61000-6-2:2001 - *Electromagnetic Compatibility (EMC), Generic Standards, Immunity for Industrial Environments*
- EN 50581:2012, Ed. 12 - *Technical Documentation for the Assessment of Electrical and Electronic Products with respect to the Restriction of Hazardous Substances.*

FCC Requirements

This product complies with FCC 47 CFR Part 15.

China RoHS

The following table serves as the declaration of hazardous substances for China in accordance with PRC standard SJ/T 11364-2014. The EFUP (Environment Friendly Use Period) for this product is 40 years.

PRODUCT: AEM-2020										
零件名称 Part Name	有害物质 Hazardous Substances									
	铅 Lead (Pb)	汞 Mercury (Hg)	镉 Cadmium (Cd)	六价铬 Hexavalent Chromium (Cr ⁶⁺)	多溴联苯 Polybrominated Biphenyls (PBB)	多溴二苯醚 Polybrominated Diphenyl Ethers (PBDE)	邻苯二甲 酸二丁酯 Dibutyl Phthalate (DBP)	邻苯二甲 酸丁苄酯 Benzyl butyl phthalate (BBP)	邻苯二甲 酸二酯 Bis(2- ethylhexyl) phthalate (BEHP)	邻苯二甲 酸二异丁 酯 Diisobutyl phthalate (DIBP)
金属零件 Metal parts	O	O	O	O	O	O	O	O	O	O
聚合物 Polymers	O	O	O	O	O	O	O	O	O	O
电子产品 Electronics	X	O	O	O	O	O	O	O	O	O
电缆和互连 配件 Cables & interconnect accessories	X	O	O	O	O	O	O	O	O	O
绝缘材料 Insulation material	O	O	O	O	O	O	O	O	O	O

本表格依据 SJ/T11364 的规定编制。

O: 表示该有害物质在该部件所有均质材料中的含量均在 GB/T 26572 规定的限量要求以下。

X: 表示该有害物质至少在该部件的某一均质材料中的含量超出 GB/T 26572 规定的限量要求。

This form was prepared according to the provisions of standard SJ/T11364.

O: Indicates that the hazardous substance content in all homogenous materials of this part is below the limit specified in standard GB/T 26572.

X: Indicates that the hazardous substance content in at least one of the homogenous materials of this part exceeds the limit specified in standard GB/T 26572.

Physical

Weight 1.80 lb (816 g)
Dimensions..... See *Mounting* later in this chapter.

Functional Description

A functional description of the AEM-2020's inputs and outputs is provided below.

Analog Inputs

The AEM-2020 provides eight analog inputs that are user-selectable for 0 to 20 mA_{dc} or –10 to 10 V_{dc}. Each analog input has under/over thresholds that can be configured as status only, alarm, or pre-alarm. When enabled, an out of range alarm alerts the user of an open or damaged analog input wire. The label text of each analog input is customizable.

RTD Inputs

The AEM-2020 provides eight user-configurable RTD inputs for monitoring genset temperature. Each RTD input can be configured as status only, alarm, or pre-alarm to protect against high or low temperature conditions. When enabled, an out of range alarm alerts the user of an open or damaged RTD input wire. The label text of each RTD input is customizable.

Thermocouple Inputs

The AEM-2020 provides two thermocouple inputs for monitoring genset temperature. Each thermocouple input can be configured as status only, alarm, or pre-alarm to protect against high or low temperature conditions. The label text of each thermocouple input is customizable.

Analog Outputs

The AEM-2020 provides four analog outputs that are user-selectable for 0 to 20 mA_{dc} or –10 to 10 V_{dc}. A wide selection of parameters including oil pressure, fuel level, generator voltage, and bus voltage can be configured as analog outputs.

Communications

A Control Area Network (CAN) is a standard interface that enables communication between the AEM-2020 and the DGC-2020HD.

Status LED

This red LED flashes to indicate that the AEM-2020 is powered up and functioning properly. The LED lights solid during power up. When the power-up sequence is complete, this LED flashes. If the LED does not flash after power up, contact Basler Electric.

Mounting

Analog Expansion Modules are delivered in sturdy cartons to prevent shipping damage. Upon receipt of a module, check the part number against the requisition and packing list for agreement. Inspect for damage, and if there is evidence of such, immediately file a claim with the carrier and notify the Basler Electric regional sales office, your sales representative, or a sales representative at Basler Electric, Highland, Illinois USA.

If the device is not installed immediately, store it in the original shipping package in a moisture- and dust-free environment.

Analog Expansion Modules are contained in a potted plastic case and may be mounted in any convenient position. The construction of an Analog Expansion Module is durable enough to mount directly on a genset using ¼-inch hardware. Hardware selection should be based on any expected

shipping/transportation and operating conditions. The torque applied to the mounting hardware should not exceed 65 in-lb (7.34 N•m).

See Figure 1-1 for AEM-2020 overall dimensions. All dimensions are shown in inches with millimeters in parenthesis.

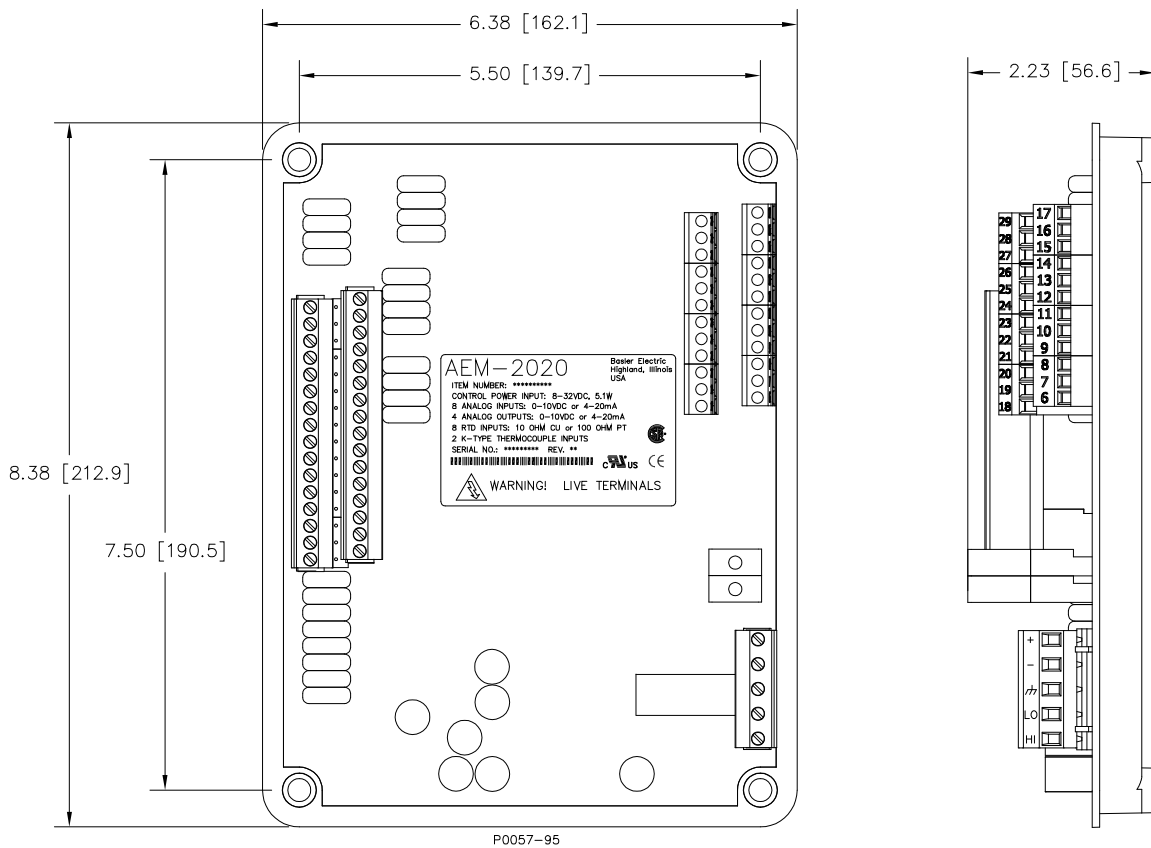

Figure 1-1. AEM-2020 Overall Dimensions

Connections

Analog Expansion Module connections are dependent on the application. Incorrect wiring may result in damage to the module.

Notes

Control power from the battery must be of the correct polarity. While reverse polarity will not cause damage, the AEM-2020 will not operate.

Be sure that the AEM-2020 is hard-wired to earth ground with no smaller than 12 AWG (3.31 mm²) copper wire attached to the chassis ground terminal on the module.

It is recommended to minimize the vibration load on the connector plug by ensuring that wires are well-constrained, with no more than 6 to 8 inches of unconstrained wire length near the connector plugs.

Terminations

The terminal interface consists of both plug-in connectors and a permanently mounted connector with screw-down compression terminals.

AEM-2020 connections are made with one 5-position connector, two 12-position connectors, two 16-position connectors, and two 2-position thermocouple connectors. The 16, 5, and 2-position connectors plug into headers on the AEM-2020. The connectors and headers have dovetailed edges that ensure proper connector orientation. Also, the connectors and headers are uniquely keyed to ensure that the connectors mate only with the correct headers. The 12-position connector is not a plug-in connector and is mounted permanently to the board. Connectors and headers may contain tin- or gold-plated conductors. Tin-plated conductors are housed in a black plastic casing and gold-plated conductors are housed in an orange plastic casing. Mate connectors to headers of the same color only.

Caution

By mating conductors of dissimilar metals, galvanic corrosion could occur which may lead to signal loss.

Connector screw terminals accept a maximum wire size of 12 AWG (3.31 mm²). Thermocouple connectors accept a maximum thermocouple wire diameter of 0.177 inches (4.5 mm). Maximum screw torque is 5 inch-pounds (0.56 N•m).

Control power

The Analog Expansion Module control power input accepts either 12 Vdc or 24 Vdc and tolerates voltage over the range of 6 to 32 Vdc. Control power must be of the correct polarity. While reverse polarity will not cause damage, the AEM-2020 will not operate. Control power terminals are listed in Table 1-1.

It is recommended that a fuse be added for additional protection for the wiring to the battery input of the Analog Expansion Module. A Bussmann ABC-7 fuse or equivalent is recommended.

Table 1-1. Control power Terminals

Terminal	Description
P1-  (SHIELD)	Chassis ground connection
P1- - (BATT-)	Negative side of control power input
P1- + (BATT+)	Positive side of control power input

AEM-2020 Inputs and Outputs

Input and output terminals are shown in Figure 1-2 and listed in Table 1-2.

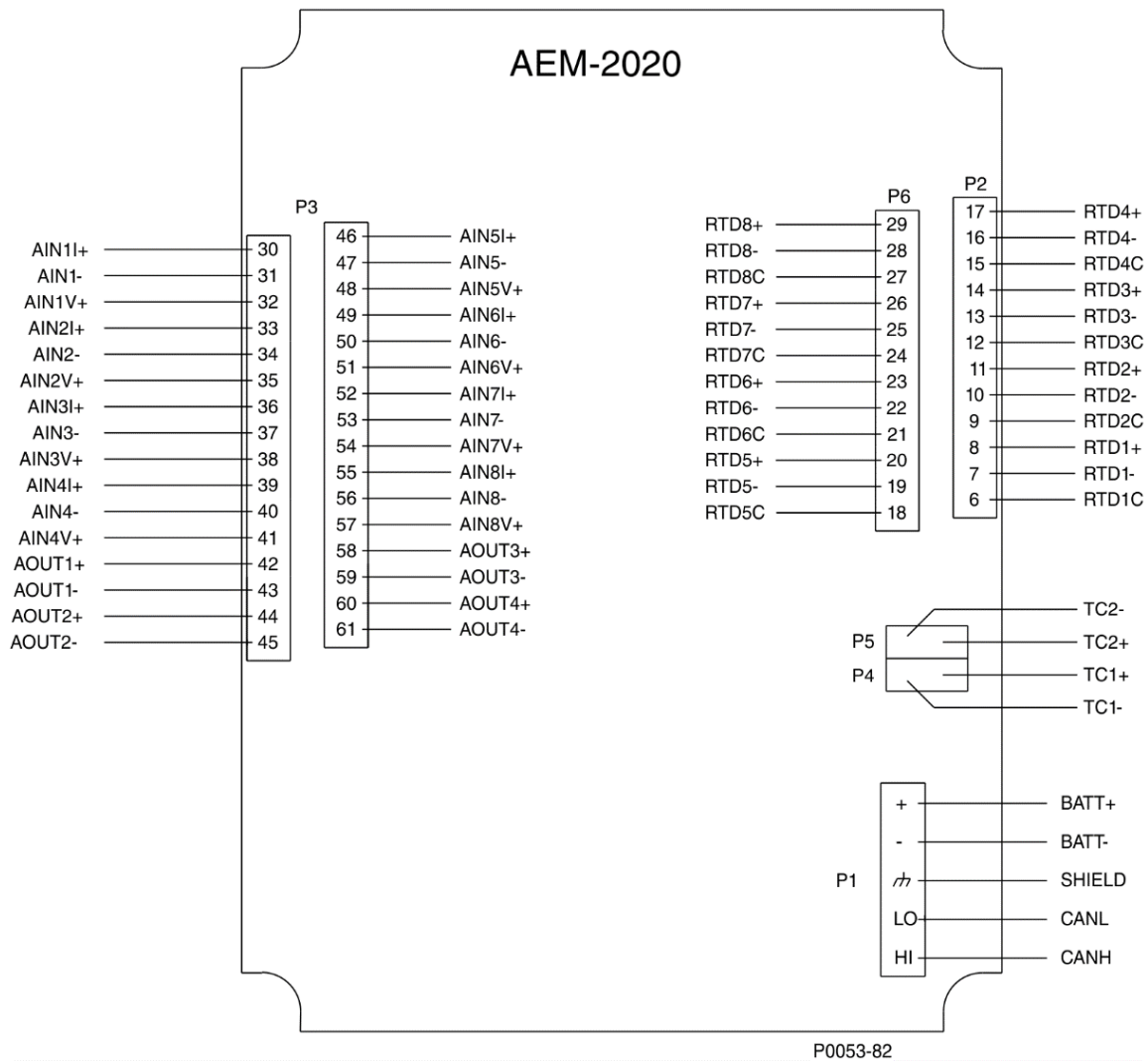

Figure 1-2. Input and Output Terminals

Table 1-2. Input and Output Terminals

Connector	Description
P1	Control power and CAN
P2	RTD Inputs 1 - 4
P3	Analog Inputs 1 - 8 and Analog Outputs 1 - 4
P4	Thermocouple 1 Input
P5	Thermocouple 2 Input
P6	RTD Inputs 5 - 8

External Analog Input Connections

Voltage input connections are shown in Figure 1-3 and current input connections are shown in Figures 1-4 through 1-6.

When using the current input, voltage across the AIN input at 20 mA is approximately 2 Vdc. The transducer power supply must be high enough to be greater than the drop in the transducer plus the voltage on the AIN input.

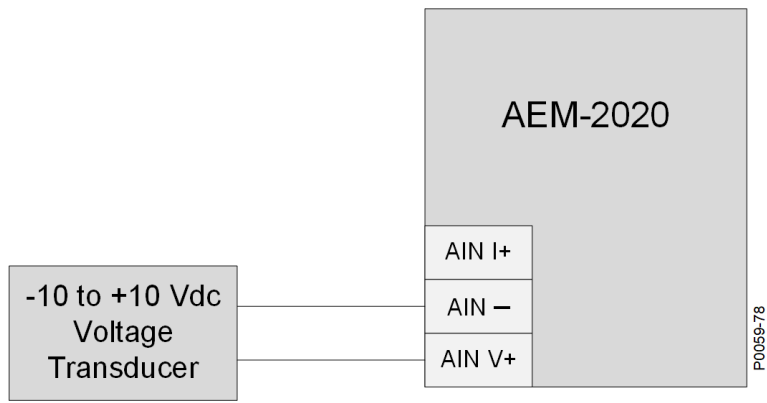

Figure 1-3. Analog Inputs - Voltage Input Connections

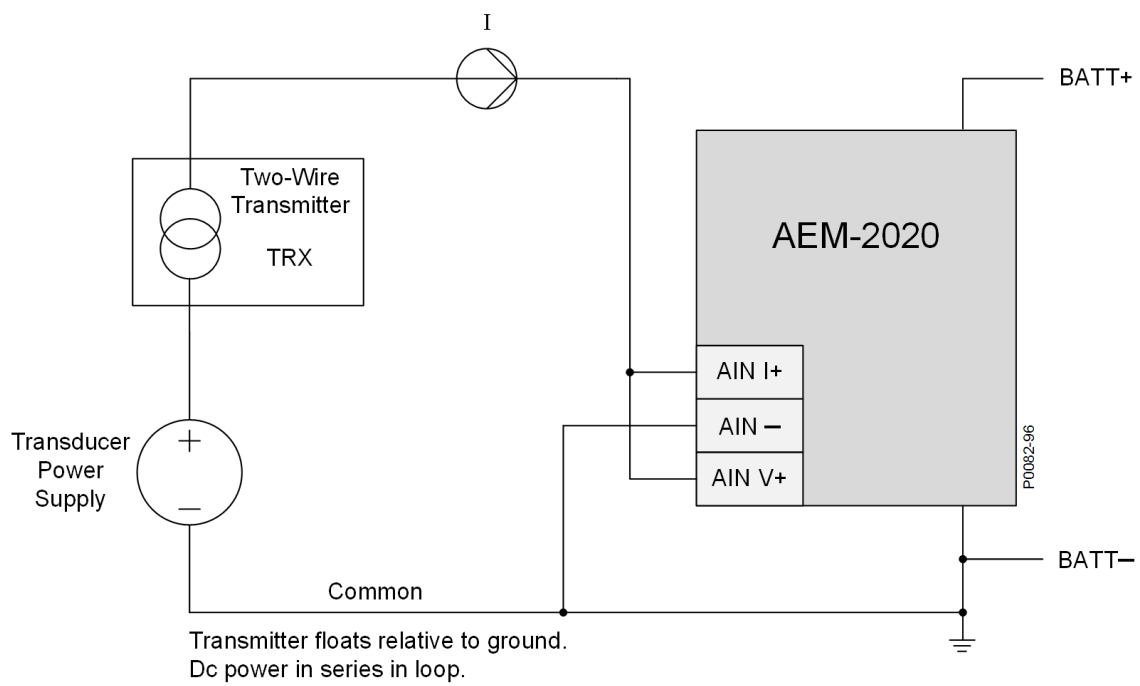

Figure 1-4. Analog Inputs - Current Input Connections, Type II 2-Wire Current Loop Circuit

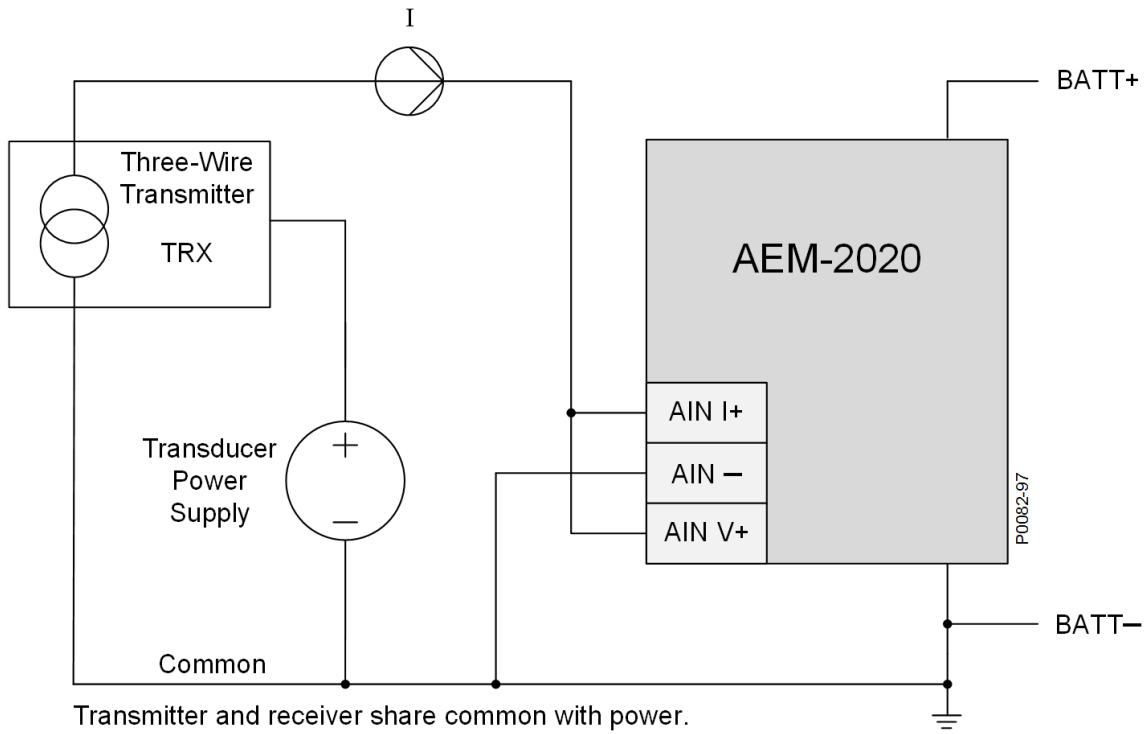

Figure 1-5. Analog Inputs - Current Input Connections, Type III 2-Wire Current Loop Circuit

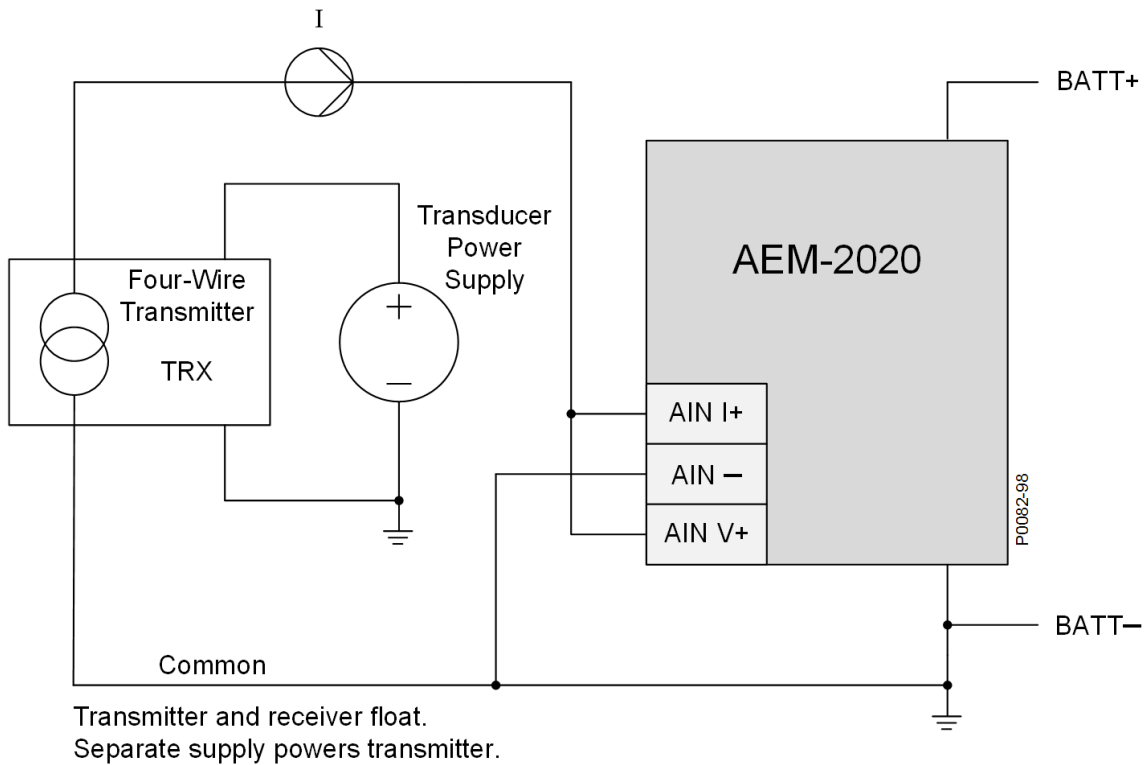

Figure 1-6. Analog Inputs - Current Input Connections, Type IV 2-Wire Current Loop Circuit

External RTD Input Connections

External 2-wire RTD input connections are shown in Figure 1-7. Figure 1-8 shows external 3-wire RTD input connections. RTD cable shields should connect to ground as close to the AEM-2020 as possible with as short a lead as practical.

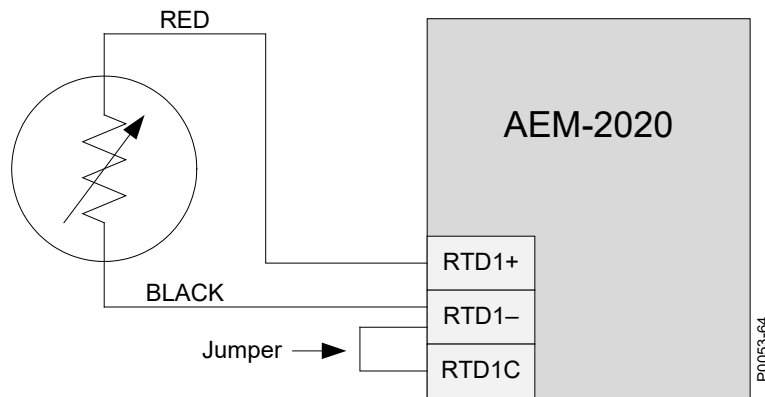

Figure 1-7. External Two-Wire RTD Input Connections

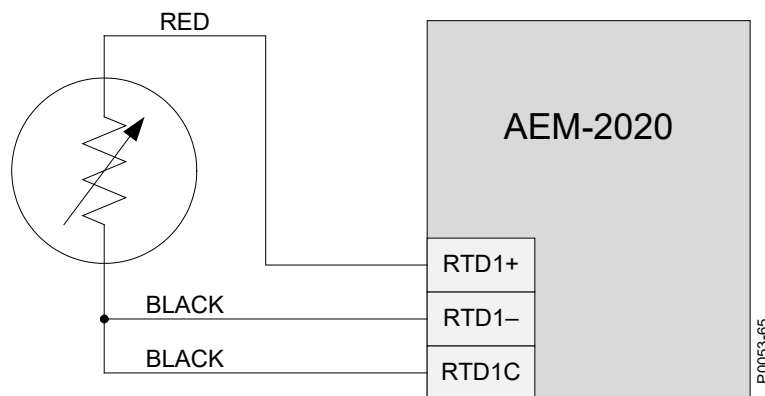



Figure 1-8. External Three-Wire RTD Input Connections

CAN Interface

These terminals provide communication using the SAE J1939 protocol and provide high-speed communication between the Analog Expansion Module and the DGC-2020HD. Connections between the AEM-2020 and DGC-2020HD should be made with twisted-pair, shielded cable. CAN interface terminals are listed in Table 1-3. Refer to Figure 1-9 and Figure 1-10.

Table 1-3. CAN Interface Terminals

Terminal	Description
P1- HI (CAN H)	CAN high connection (yellow wire)
P1- LO (CAN L)	CAN low connection (green wire)
P1-  (SHIELD)	CAN drain connection

Notes

1. If the AEM-2020 is providing one end of the J1939 bus, a 120 Ω , ½ watt terminating resistor should be installed across terminals P1- LO (CANL) and P1- HI (CANH).
2. If the AEM-2020 is not part of the J1939 bus, the stub connecting the AEM-2020 to the bus should not exceed 914 mm (3 ft) in length.
3. The maximum bus length, not including stubs, is 40 m (131 ft).
4. The J1939 drain (shield) should be grounded at one point only. If grounded elsewhere, do not connect the drain to the AEM-2020.

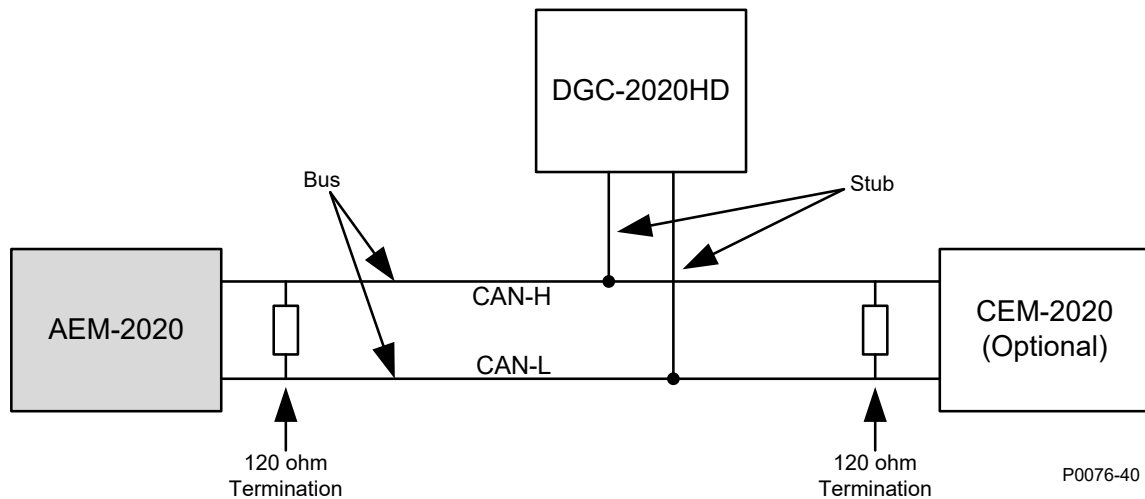

Figure 1-9. CAN Interface with AEM-2020 providing One End of the Bus

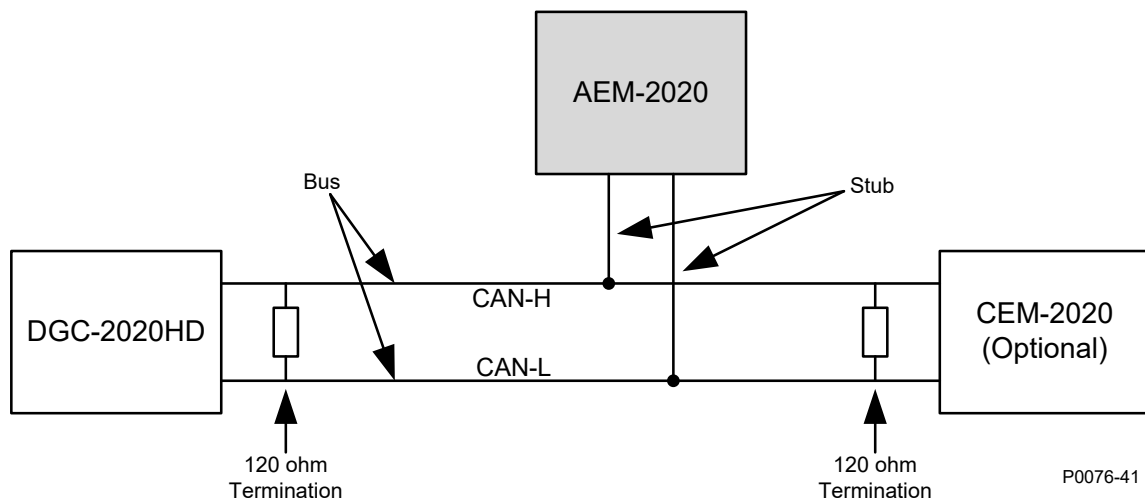

Figure 1-10. CAN Interface with DGC-2020HD providing One End of the Bus

AEM-2020 Configuration

AEM-2020s are enabled on the Remote Module Setup screen in BESTCOMSPPlus®. If more than one AEM-2020 is connected, the serial number of each module must be entered. An AEM Not Configured pre-alarm will occur if the expected serial number does not match the serial number detected on the General Settings, Device Info screen. The Remote Module Setup screen is illustrated in Figure 1-11.

Remote Module Setup

Contact Expansion Module 1
 Module Enable
 Disable
 Enable
 J1939 Address: 236
 CEM Outputs: 18 Outputs
 Expected Serial Number: NA

Contact Expansion Module 2
 Module Enable
 Disable
 Enable
 J1939 Address: 236
 CEM Outputs: 18 Outputs
 Expected Serial Number: NA

Contact Expansion Module 3
 Module Enable
 Disable
 Enable
 J1939 Address: 236
 CEM Outputs: 18 Outputs
 Expected Serial Number: NA

Contact Expansion Module 4
 Module Enable
 Disable
 Enable
 J1939 Address: 236
 CEM Outputs: 18 Outputs
 Expected Serial Number: NA

Contact Expansion Module 5
 Module Enable
 Disable
 Enable
 J1939 Address: 236
 CEM Outputs: 18 Outputs
 Expected Serial Number: NA

Contact Expansion Module 6
 Module Enable
 Disable
 Enable
 J1939 Address: 236
 CEM Outputs: 18 Outputs
 Expected Serial Number: NA

Analog Expansion Module 1
 Module Enable
 Disable
 Enable
 J1939 Address: 237
 Expected Serial Number: NA

Analog Expansion Module 2
 Module Enable
 Disable
 Enable
 J1939 Address: 237
 Expected Serial Number: NA

Analog Expansion Module 3
 Module Enable
 Disable
 Enable
 J1939 Address: 237
 Expected Serial Number: NA

Analog Expansion Module 4
 Module Enable
 Disable
 Enable
 J1939 Address: 237
 Expected Serial Number: NA

Voltage Regulation Module
 Module Enable
 Disable
 Enable
 J1939 Address: 238

Figure 1-11. Settings Explorer, System Parameters, Remote Module Setup

Remote Analog Inputs Configuration

Eight remote analog inputs provide metering for a variety of industrial transducers. An element can be configured to trip when the metered input increases above or decreases below the user-defined threshold.

The eight, identical remote analog input protection elements are designated AEM x Input #1 through AEM x Input #8 (where x = 1 to 4). Element logic connections are made on the BESTlogicPlus screen in BESTCOMSPius and element operational settings are configured on the AEM x Input #y (where x = 1 to 4 and y = 1 to 8) settings screen in BESTCOMSPius.

BESTCOMSPius Navigation Path: Settings Explorer, Programmable Inputs, Remote Analog Inputs

Front Panel Navigation Path: Settings Explorer > Programmable Inputs > Remote Analog Inputs

Input Setup

Label Text

In order to make identification of the remote analog inputs easier, each of the inputs can be given a user-assigned label. The label is an alphanumeric string with a maximum of 16 characters.

Hysteresis

The hysteresis setting provides a level of hysteresis between a threshold detection tripping and dropping out. For instance, if the hysteresis is set for 5% and the threshold is set as an over threshold, once the threshold detection trips, the measured value must drop to 95% of the threshold before the threshold detection will drop out. This hysteresis helps prevent rapid or repeated transitions between trip and dropout in cases where the measured input is nearly equal to a level equal to the threshold.

If the threshold is set as an under threshold with 5% hysteresis, once the threshold detection trips, the measured value must rise to 105% of the threshold before the threshold detection will drop out.

Input Type

A remote analog input can be configured to monitor a voltage or current signal.

Arming Delay

A user-adjustable arming delay disables remote analog input protection during engine startup. If the arming delay is set to zero (0), the input protection is active at all times, including when the engine is not running. If the arming delay is set to a non-zero value, the input protection is inactive when the engine is

not running, and does not become active until after the engine is started and the arming delay has elapsed.

Out-of-Range Alarm Type

An out-of-range alarm alerts the user of an open or damaged analog input wire. This setting determines the action that is taken when an input becomes out-of-range. See *Alarm Configuration* below for descriptions of the settings.

Ranges

Ranges must be set for the selected input type. Param Min correlates to Min Input Current or Min Input Voltage and Param Max correlates to Max Input Current or Max Input Voltage.

Out of Range Detection

Use the Current Range Min and Current Range Max or Voltage Range Min and Voltage Range Max settings to establish the valid input range. When the measured current or voltage is outside of the established range, the corresponding out-of-range logic output becomes true. In *BESTlogicPlus*, the output can be connected to other logic elements or a physical relay output to annunciate the condition and initiate corrective action. See the *BESTlogicPlus* chapter in the *DGC-2020HD Configuration Manual* (Basler publication 9469300995) for more information about analog input out-of-range alarm and pre-alarm logic blocks.

Thresholds

There are four programmable thresholds for each remote analog input element. Each threshold has a mode setting, threshold setting, activation delay setting, and an alarm setting.

Mode

The mode can be set for Over or Under. If Over mode is selected, an alarm is annunciated when the metered input increases above the Threshold setting for the duration of the Activation Delay. If Under mode is selected, an alarm is annunciated when the metered input decreases below the Threshold setting for the duration of the Activation Delay.

Threshold

When the metered input rises above or falls below this setting, depending on the Mode setting, (picks up) the activation delay timer begins counting.

Activation Delay

After the threshold has been exceeded for the duration of the activation delay, the selected alarm configuration action is performed. If the threshold detection drops out before the activation delay expires, the activation delay timer is reset.

Alarm Configuration

Each analog input threshold item can be independently configured to perform a different action depending on the alarm configuration setting. Alarm configurations are described in the *Reporting and Alarms* chapter in the *Operation* manual.

Logic Connections

Remote analog input protection logic connections are made on the *BESTlogicPlus* screen in *BESTCOMSPlus*. The Analog Input 1, Threshold 1 logic block is illustrated in Figure 1-12. The output is true during a trip condition. The alarm and pre-alarm logic blocks are similar.

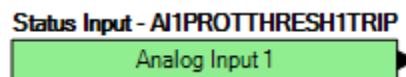

Figure 1-12. Remote Analog Input Protection Logic Block

Operational Settings

Remote analog input protection operational settings are configured on the AEM x Input #y (where x = 1 to 4 and y = 1 to 8) settings screen (Figure 1-13) in *BESTCOMSPi.us*.

Figure 1-13. Settings Explorer, Programmable Inputs, Remote Analog Inputs, AEM 1 Input #1

Remote RTD Inputs Configuration

Eight remote RTD inputs provide metering of winding or bearing temperatures. An element can be configured to trip when the metered input increases above or decreases below the user-defined threshold.

The eight, identical remote RTD input protection elements are designated AEM x RTD Input #1 through AEM x RTD Input #8 (where x = 1 to 4). Element logic connections are made on the *BESTlogicPi.us* screen in *BESTCOMSPi.us* and element operational settings are configured on the AEM x RTD Input #y (where x = 1 to 4 and y = 1 to 8) settings screen in *BESTCOMSPi.us*.

BESTCOMSPi.us Navigation Path: Settings Explorer, Programmable Inputs, Remote RTD Inputs

Front Panel Navigation Path: Settings Explorer > Programmable Inputs > Remote RTD Inputs

Input Setup

Label Text

In order to make identification of the remote RTD inputs easier, each of the inputs can be given a user-assigned label. The label is an alphanumeric string with a maximum of 16 characters.

Hysteresis

The hysteresis setting provides a level of hysteresis between a threshold detection tripping and dropping out. For instance, if the hysteresis is set for 5% and the threshold is set as an over threshold, once the threshold detection trips, the measured value must drop to 95% of the threshold before the threshold detection will drop out. This hysteresis helps prevent rapid or repeated transitions between trip and dropout in cases where the measured input is nearly equal to a level equal to the threshold.

If the threshold is set as an under threshold with 5% hysteresis, once the threshold detection trips, the measured value must rise to 105% of the threshold before the threshold detection will drop out.

Input Type

A remote RTD input can be configured to monitor a 10 Ω copper or 100 Ω platinum RTD.

Arming Delay

A user-adjustable arming delay disables remote RTD input protection during engine startup. If the arming delay is set to zero (0), the input protection is active at all times, including when the engine is not running. If the arming delay is set to a non-zero value, the input protection is inactive when the engine is not running, and does not become active until after the engine is started and the arming delay has elapsed.

Out-of-Range Alarm Type

An out-of-range alarm alerts the user of an open or damaged remote RTD input wire. This setting determines the action that is taken when an input becomes out-of-range. See *Alarm Configuration* below for descriptions of the settings.

Ranges

Ranges must be set for the selected input type. Param Min correlates to Min Input Current or Min Input Voltage and Param Max correlates to Max Input Current or Max Input Voltage.

Thresholds

There are four programmable thresholds for each remote RTD input element. Each threshold has a mode setting, threshold setting, activation delay setting, and an alarm setting.

Mode

The mode can be set for Over or Under. If Over mode is selected, an alarm is annunciated when the metered input increases above the Threshold setting for the duration of the Activation Delay. If Under mode is selected, an alarm is annunciated when the metered input decreases below the Threshold setting for the duration of the Activation Delay.

Threshold

When the metered input rises above or falls below this setting, depending on the Mode setting, (picks up) the activation delay timer begins counting.

Activation Delay

After the threshold has been exceeded for the duration of the activation delay, the selected alarm configuration action is performed. If the threshold detection drops out before the activation delay expires, the activation delay timer is reset.

Alarm Configuration

Each remote RTD input protection threshold item can be independently configured to perform a different action depending on the alarm configuration setting. Alarm configurations are described in the *Reporting and Alarms* chapter in the *Operation* manual.

Logic Connections

Remote RTD input protection logic connections are made on the BESTlogicPlus screen in BESTCOMSPPlus. The RTD Input 1, Threshold 1 logic block is illustrated in Figure 1-14. The output is true during a trip condition. The alarm and pre-alarm logic blocks are similar.

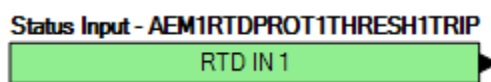

Figure 1-14. Remote RTD Input Protection Logic Block

Operational Settings

Remote RTD input protection operational settings are configured on the AEM x RTD Input #y (where x = 1 to 4 and y = 1 to 8) settings screen (Figure 1-15) in BESTCOMSPPlus.

Figure 1-15. Settings Explorer, Programmable Inputs, Remote Analog Inputs, AEM 1 RTD Input #1

Remote Thermocouple Inputs Configuration

Two remote thermocouple inputs provide metering of exhaust temperatures. An element can be configured to trip when the metered input increases above or decreases below the user-defined threshold.

The two, identical remote thermocouple input protection elements are designated AEM x Thermocouple Input #1 and AEM x Thermocouple Input #2 (where x = 1 to 4). Element logic connections are made on the BESTlogicPlus screen in BESTCOMSPPlus and element operational settings are configured on the AEM x Thermocouple Input #y (where x = 1 to 4 and y = 1 or 2) settings screen in BESTCOMSPPlus.

BESTCOMSPPlus Navigation Path: Settings Explorer, Programmable Inputs, Remote Thermocouple Inputs

Front Panel Navigation Path: Settings Explorer > Programmable Inputs > Remote Thermocouple Inputs

Input Setup

Label Text

In order to make identification of the remote thermocouple inputs easier, each of the inputs can be given a user-assigned label. The label is an alphanumeric string with a maximum of 16 characters.

Hysteresis

The hysteresis setting provides a level of hysteresis between a threshold detection tripping and dropping out. For instance, if the hysteresis is set for 5% and the threshold is set as an over threshold, once the threshold detection trips, the measured value must drop to 95% of the threshold before the threshold detection will drop out. This hysteresis helps prevent rapid or repeated transitions between trip and dropout in cases where the measured input is nearly equal to a level equal to the threshold.

If the threshold is set as an under threshold with 5% hysteresis, once the threshold detection trips, the measured value must rise to 105% of the threshold before the threshold detection will drop out.

Arming Delay

A user-adjustable arming delay disables remote thermocouple input protection during engine startup. If the arming delay is set to zero (0), the input protection is active at all times, including when the engine is not running. If the arming delay is set to a non-zero value, the input protection is inactive when the engine is not running, and does not become active until after the engine is started and the arming delay has elapsed.

Thresholds

There are four programmable thresholds for each remote thermocouple input element. Each threshold has a mode setting, threshold setting, activation delay setting, and an alarm setting.

Mode

The mode can be set for Over or Under. If Over mode is selected, an alarm is annunciated when the metered input increases above the Threshold setting for the duration of the Activation Delay. If Under mode is selected, an alarm is annunciated when the metered input decreases below the Threshold setting for the duration of the Activation Delay.

Threshold

When the metered input rises above or falls below this setting (picks up), depending on the Mode setting, the activation delay timer begins counting.

Activation Delay

After the threshold has been exceeded for the duration of the activation delay, the selected alarm configuration action is performed. If the threshold detection drops out before the activation delay expires, the activation delay timer is reset.

Alarm Configuration

Each remote thermocouple input protection threshold item can be independently configured to perform a different action depending on the alarm configuration setting. Alarm configurations are described in the *Reporting and Alarms* chapter in the *Operation* manual.

Logic Connections

Remote thermocouple input protection logic connections are made on the BESTlogicPlus screen in BESTCOMSPlus. The Thermocouple Input 1, Threshold 1 Status Input logic block is illustrated in Figure 1-16. The output is true during a trip condition. The alarm and pre-alarm logic blocks are similar.

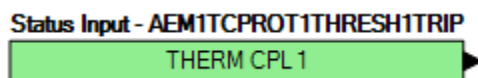

Figure 1-16. Remote Thermocouple Input Protection Logic Block

Operational Settings

Remote Thermocouple input protection operational settings are configured on the AEM x Thermocouple Input #y (where x = 1 to 4 and y = 1 or 2) settings screen (Figure 1-17) in BESTCOMSPi.us.

AEM 1 Thermocouple Input #1

Label Text
AEM1 TC1

Arming Delay (s)
0

Hysteresis (%)
2.0

Threshold #1			
Mode	Threshold (°F)	Activation Delay (s)	Alarm Configuration
Disabled	32	0	Status Only

Threshold #2			
Mode	Threshold (°F)	Activation Delay (s)	Alarm Configuration
Disabled	32	0	Status Only

Threshold #3			
Mode	Threshold (°F)	Activation Delay (s)	Alarm Configuration
Disabled	32	0	Status Only

Threshold #4			
Mode	Threshold (°F)	Activation Delay (s)	Alarm Configuration
Disabled	32	0	Status Only

Figure 1-17. Settings Explorer, Programmable Inputs, Remote Analog Inputs, AEM 1 Thermocouple Input #1

Remote Analog Outputs Configuration

Four remote analog outputs provide voltage or current signals from the AEM-2020 to a variety of industrial transducers.

The four, identical remote analog outputs are designated AEM x Output #1 through AEM x Output #4 (where x = 1 to 4). Remote analog output operational settings are configured on the AEM x Output #y (where x = 1 to 4 and y = 1 to 4) settings screen in BESTCOMSPi.us.

BESTCOMSPi.us Navigation Path: Settings Explorer, Programmable Outputs, Remote Analog Outputs

Front Panel Navigation Path: Settings Explorer > Programmable Outputs > Remote Analog Outputs

Output Setup

Parameter Selection

A wide variety of parameters can be selected.

Output Type

A remote analog output can be configured to provide a voltage or current signal.

Out-of-Range Alarm Type

An out of range alarm alerts the user of an open or damaged analog output wire. This setting determines the action that is taken when an input becomes out-of-range. Alarm configurations are described in the *Reporting and Alarms* chapter in the *Operation* manual.

Out-of-Range Activation Delay

An out of range activation delay setting delays alarm annunciation.

Ranges

Ranges must be set for the selected output type. Param Min correlates to Min Output Current or Min Output Voltage and Param Max correlates to Max Output Current or Max Output Voltage.

Operational Settings

Remote analog output operational settings are configured on the AEM x Output #y (where x = 1 to 4 and y = 1 to 4) settings screen (Figure 1-18) in *BESTCOMSPi.us*.

AEM 1 Output #1

Parameter Selection Oil Pressure	Out Of Range Alarm Type Status Only
Output Type Voltage	Out of Range Activation Delay (s) 0

Ranges		
Param Min (PSI)	Min Output Current (mA)	Min Output Voltage (V)
-999999	4.0	0.0
Param Max (PSI)	Max Output Current (mA)	Max Output Voltage (V)
999999	20.0	10.0

Figure 1-18. Settings Explorer, Programmable Outputs, Remote Analog Outputs, AEM 1 Output #1

Firmware Updates

Refer to the *Device Information* chapter in the *Configuration* manual for information on upgrading firmware in the AEM-2020.

Repair

Analog Expansion Modules are manufactured using state-of-the-art surface-mount technology. As such, Basler Electric recommends that no repair procedures be attempted by anyone other than Basler Electric personnel.

Before returning the AEM-2020 for repair, contact Basler Electric for a return authorization number.

Maintenance

Preventive maintenance consists of periodically checking that the connections between the AEM-2020 and the system are clean and tight.

Storage

This device contains long-life aluminum electrolytic capacitors. For devices that are not in service (spares in storage), the life of these capacitors can be maximized by energizing the device for 30 minutes once per year.

2 • CEM-2020

The Contact Expansion Module (CEM-2020) is an optional remote device that provides additional DGC-2020HD contact inputs and outputs. Two types of modules are available. A low current module (CEM-2020) provides 24 contact outputs and high current module (CEM-2020H) provides 18 contact outputs. A CAN interface configured for 250 kbps supports the following combinations of AEM-2020, CEM-2020 and VRM-2020 modules:

- Up to six CEM-2020s, two AEM-2020s, and one VRM-2020
- Up to five CEM-2020s, three AEM-2020s, and one VRM-2020
- Up to four CEM-2020s, four AEM-2020s, and one VRM-2020

Features

CEM-2020s have the following features:

- 10 Contact Inputs
- 18 Contact Outputs (CEM-2020H) or 24 Contact Outputs (CEM-2020)
- Functionality of Inputs and Outputs assigned by BESTlogic™ *Plus* Programmable Logic
- Communications via CAN

Specifications

Control Power

Nominal 12 or 24 Vdc
 Range..... 8 to 32 Vdc (Withstands cranking ride-through down to 6 Vdc for 500 ms)

Maximum Consumption

CEM-2020 14 W
 CEM-2020H 8 W

Contact Inputs

The CEM-2020 contains 10 programmable inputs that accept dry contacts.

Time from a CEM-2020 input application to:

- Shut down the generator via an alarm = 700 ms max
- Close a relay on board the DGC-2020HD = 300 ms max
- Close a relay on board the CEM-2020 = 550 ms max

Notes

A contact input is true (on) if the input is connected to battery ground with a resistance of less than 200 ohms.

The maximum length of wire that can be accommodated depends on the resistance of the wire, and the resistance of the contacts of the device driving the input at the far end of the wire.

The maximum wire length can be calculated as follows:

$$L_{\max} = (200 - R_{\text{device}}) / (\text{Resistance per Foot of Desired Wire})$$

Contact Outputs

Ratings

CEM-2020

Outputs 1 through 12 1 Adc at 30 Vdc, Form C, gold contacts*

Outputs 13 through 24 4 Adc at 30 Vdc, Form C, 1.2 A pilot duty†

CEM-2020H

Outputs 1 through 12 2 Adc at 30 Vdc, Form C, gold contacts*

Outputs 13 through 18 10 Adc at 30 Vdc, Form C, 1.2 A pilot duty†

* Gold contacts intended for low voltage signaling to dry circuits. Not rated for inductive loads or pilot duty.

† For pilot duty, the load must be in parallel with a diode rated at least 3 x the coil current and 3 x the coil voltage.

CAN Interface

Differential Bus Voltage..... 1.5 to 3 Vdc

Maximum Voltage -32 to +32 Vdc with respect to negative battery terminal

Communication Rate..... 250 kb/s

Type Tests

Shock

Withstands 15 G in 3 perpendicular planes.

Vibration

Swept over the following ranges for 12 sweeps in each of three mutually perpendicular planes with each 15-minute sweep consisting of the following:

5 to 29 to 5 Hz 1.5 G peak for 5 minutes

29 to 52 to 29 Hz 0.036 in (0.914 mm) Double Amplitude for 2.5 minutes

52 to 500 to 52 Hz 5 G peak for 7.5 minutes

Ignition System

Tested in close proximity to an unshielded, unsuppressed Altronic DISN 800 ignition system.

HALT (Highly Accelerated Life Testing)

HALT is used by Basler Electric to prove that our products will provide the user with many years of reliable service. HALT subjects the device to extremes in temperature, shock, and vibration to simulate years of operation, but in a much shorter period span. HALT allows Basler Electric to evaluate all possible design elements that will add to the life of this device. As an example of some of the extreme testing conditions, the CEM-2020 was subjected to temperature tests (tested over a temperature range of -80°C to +130°C), vibration tests (of 5 to 50 G at +25°C), and temperature/vibration tests (tested at 10 to 20 G over a temperature range of -60°C to +100°C). Combined temperature and vibration testing at these extremes proves that the CEM-2020 is expected to provide long-term operation in a rugged environment. Note that the vibration and temperature extremes listed in this paragraph are specific to HALT and do not reflect recommended operation levels. These operational ratings are included in this section.

Environment

Operating Temperature -40 to +158°F (-40 to +70°C)

Storage Temperature -40 to +185°F (-40 to +85°C)

Humidity Meets IEC 68-2-38

Agency Standards and Directives

Maritime Recognition

American Bureau of Shipping (ABS) – For current certificates, see www.basler.com.

UL Approval

The CEM-2020 is a Recognized Component for the US and Canada under UL file E97035 (CCN-FTPM2/FTPM8) covered under the Standards below:

- UL 6200
- CSA C22.2 No.14-13

CE Compliance

This product complies with the requirements of the following EC Directives:

- Low Voltage Directive (LVD) 2014/35/EU
- Electromagnetic Compatibility (EMC) 2014/30/EU
- Hazardous Substances (RoHS 2) - 2011/65/EU

This product conforms to the following Harmonized Standards:

- EN 50178:1997 - *Electronic Equipment for use in Power Installations*
- EN 61000-6-4:2001 - *Electromagnetic Compatibility (EMC), Generic Standards, Emission Standard for Industrial Environments*
- EN 61000-6-2:2001 - *Electromagnetic Compatibility (EMC), Generic Standards, Immunity for Industrial Environments*
- EN 50581:2012, Ed. 12 - *Technical Documentation for the Assessment of Electrical and Electronic Products with respect to the Restriction of Hazardous Substances.*

FCC Requirements

This product complies with FCC 47 CFR Part 15.

China RoHS

The following table serves as the declaration of hazardous substances for China in accordance with PRC standard SJ/T 11364-2014. The EFUP (Environment Friendly Use Period) for this product is 40 years.

PRODUCT: CEM-2020										
零件名称 Part Name	有害物质 Hazardous Substances									
	铅 Lead (Pb)	汞 Mercury (Hg)	镉 Cadmium (Cd)	六价铬 Hexavalent Chromium (Cr ⁶⁺)	多溴联苯 Polybrominated Biphenyls (PBB)	多溴二苯醚 Polybrominated Diphenyl Ethers (PBDE)	邻苯二甲 酸二丁酯 Dibutyl Phthalate (DBP)	邻苯二甲 酸丁苄酯 Benzyl butyl phthalate (BBP)	邻苯二甲 酸二酯 Bis(2- ethylhexyl) phthalate (BEHP)	邻苯二甲 酸二异丁 酯 Diisobutyl phthalate (DIBP)
金属零件 Metal parts	○	○	○	○	○	○	○	○	○	○
聚合物 Polymers	○	○	○	○	○	○	○	○	○	○
电子产品 Electronics	X	○	X	○	○	○	○	○	○	○
电缆和互连 配件 Cables & interconnect accessories	○	○	○	○	○	○	○	○	○	○
绝缘材料 Insulation material	○	○	○	○	○	○	○	○	○	○

本表格依据 SJ/T11364 的规定编制。

O: 表示该有害物质在该部件所有均质材料中的含量均在 GB/T 26572 规定的限量要求以下。

X: 表示该有害物质至少在该部件的某一均质材料中的含量超出 GB/T 26572 规定的限量要求。

This form was prepared according to the provisions of standard SJ/T11364.

O: Indicates that the hazardous substance content in all homogenous materials of this part is below the limit specified in standard GB/T 26252.

X: Indicates that the hazardous substance content in at least one of the homogenous materials of this part exceeds the limit specified in standard GB/T 26572.

PhysicalWeight

CEM-2020 2.25 lb (1.02 kg)
CEM-2020H 1.90 lb (0.86 kg)

Dimensions

See *Mounting* later in this chapter.

Functional Description

A functional description of the CEM-2020s inputs and outputs is provided below.

Contact Inputs

The CEM-2020 provides 10 programmable contact inputs with the same functionality as the contact inputs on the DGC-2020HD. The label text of each contact input is customizable.

Contact Outputs

CEM-2020

The CEM-2020 provides 24 programmable contact outputs with the same functionality as the contact outputs on the DGC-2020HD. Outputs 1 through 12 can carry 1 A. Outputs 13 through 24 can carry 4 A. The label text of each contact output is customizable.

CEM-2020H

The CEM-2020H provides 18 programmable contact outputs with the same functionality as the contact outputs on the DGC-2020HD. Outputs 1 through 12 can carry 2 A. Outputs 13 through 18 can carry 10 A. The label text of each contact output is customizable.

Communications

A Control Area Network (CAN) is a standard interface that enables communication between the CEM-2020 and the DGC-2020HD.

Mounting

Contact Expansion Modules are delivered in sturdy cartons to prevent shipping damage. Upon receipt of a module, check the part number against the requisition and packing list for agreement. Inspect for damage, and if there is evidence of such, immediately file a claim with the carrier and notify the Basler Electric regional sales office, your sales representative, or a sales representative at Basler Electric, Highland, Illinois USA.

If the device is not installed immediately, store it in the original shipping package in a moisture- and dust-free environment.

Contact Expansion Modules are contained in a potted plastic case and may be mounted in any convenient position. The construction of a Contact Expansion Module is durable enough to mount directly on a genset using ¼-inch hardware. Hardware selection should be based on any expected shipping/transportation and operating conditions. The torque applied to the mounting hardware should not exceed 65 in-lb (7.34 N•m).

See Figure 2-1 for CEM-2020 overall dimensions. All dimensions are shown in inches with millimeters in parenthesis.

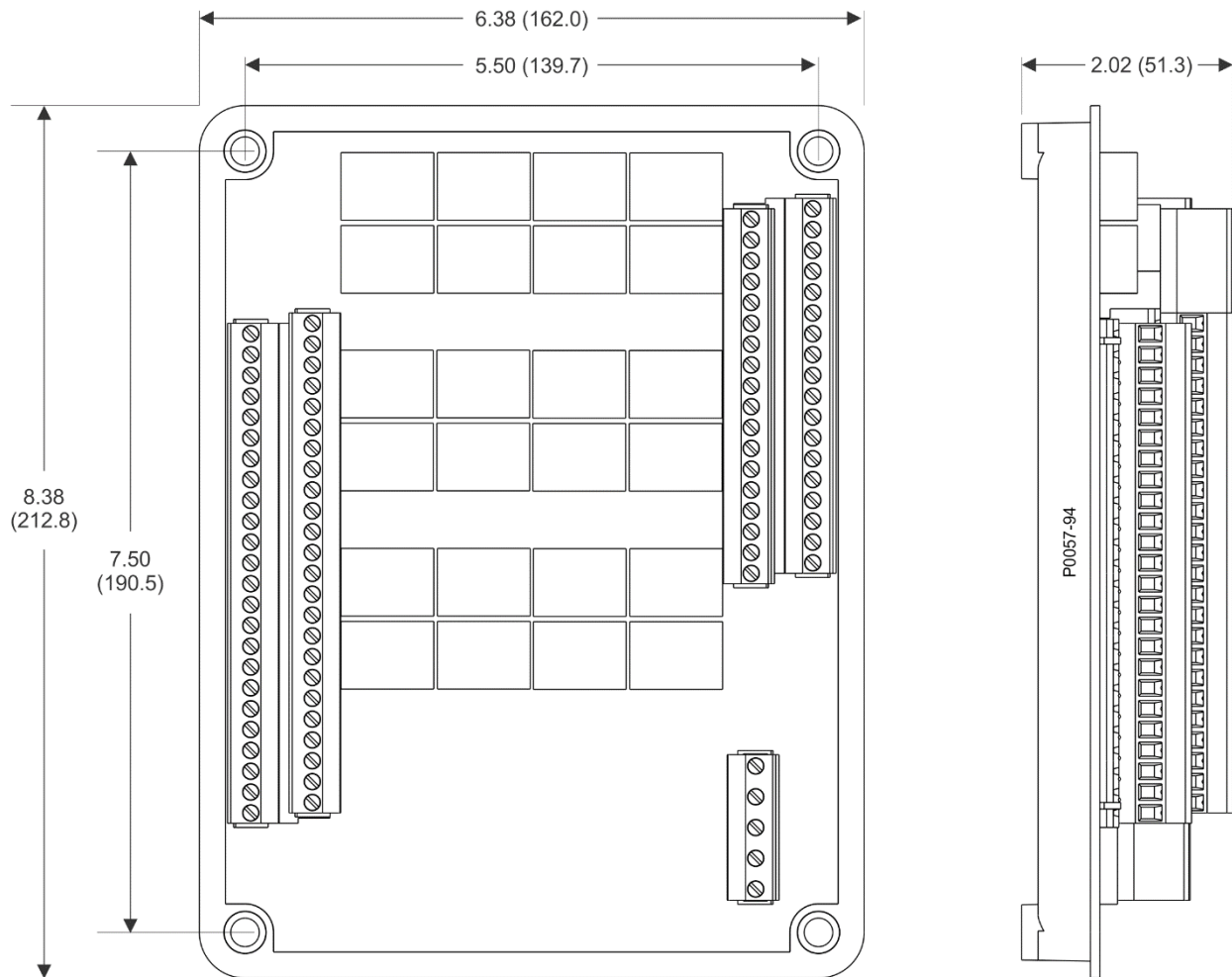

Figure 2-1. CEM-2020 Overall Dimensions

See Figure 2-2 for CEM-2020H overall dimensions. All dimensions are shown in inches with millimeters in parenthesis.

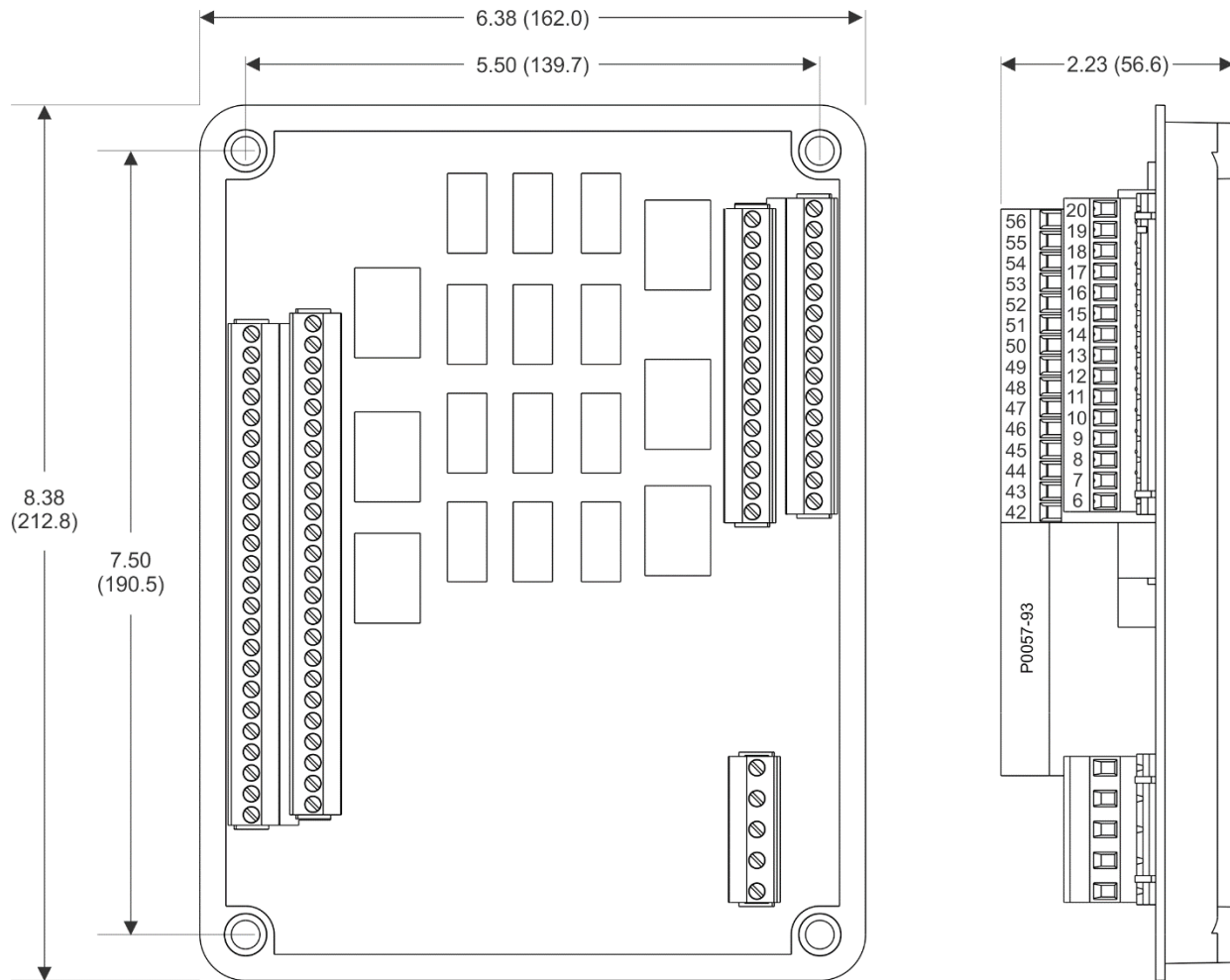

Figure 2-2. CEM-2020H Overall Dimensions

Connections

Contact Expansion Module connections are dependent on the application. Incorrect wiring may result in damage to the module.

Notes

Control power from the battery must be of the correct polarity. Although reverse polarity will not cause damage, the CEM-2020 will not operate.

Be sure that the CEM-2020 is hard-wired to earth ground with no smaller than 12 AWG (3.31 mm²) copper wire attached to the chassis ground terminal on the module.

It is recommended to minimize the vibration load on the connector plug by ensuring that wires are well-constrained, with no more than 6 to 8 inches of unconstrained wire length near the connector plugs.

Terminations

The terminal interface consists of plug-in connectors with screw-down compression terminals.

CEM-2020 connections are made with one 5-position connector, two 18-position connectors, and two 24-position connectors with screw-down compression terminals. These connectors plug into headers on the CEM-2020. Also, the connectors and headers have dovetailed edges that ensure proper connector orientation. The connectors and headers are uniquely keyed to ensure that the connectors mate with only the correct headers.

Caution

By mating conductors of dissimilar metals, galvanic corrosion could occur which may lead to signal loss.

Connectors and headers may contain tin- or gold-plated conductors. Tin-plated conductors are housed in a black plastic casing and gold-plated conductors are housed in an orange plastic casing. Mate connectors to headers of only the same color.

Connector screw terminals accept a maximum wire size of 12 AWG (3.31 mm²). Maximum screw torque is 5 inch-pounds (0.56 N•m).

Control power

The Contact Expansion Module control power input accepts either 12 Vdc or 24 Vdc and tolerates voltage over the range of 6 to 32 Vdc. Control power must be of the correct polarity. Although reverse polarity will not cause damage, the CEM-2020 will not operate. Control power terminals are listed in Table 2-1.

It is recommended that a fuse be added for additional protection for the wiring to the battery input of the Contact Expansion Module. A Bussmann ABC-7 fuse or equivalent is recommended.

Table 2-1. Control power Terminals

Terminal	Description
P1-  (SHIELD)	Chassis ground connection
P1- – (BATT–)	Negative side of control power input
P1- + (BATT+)	Positive side of control power input

Contact Inputs and Contact Outputs

The CEM-2020 (Figure 2-3) has 10 contact inputs and 24 contact outputs. The CEM-2020H (Figure 2-4) has 10 contact inputs and 18 contact outputs.

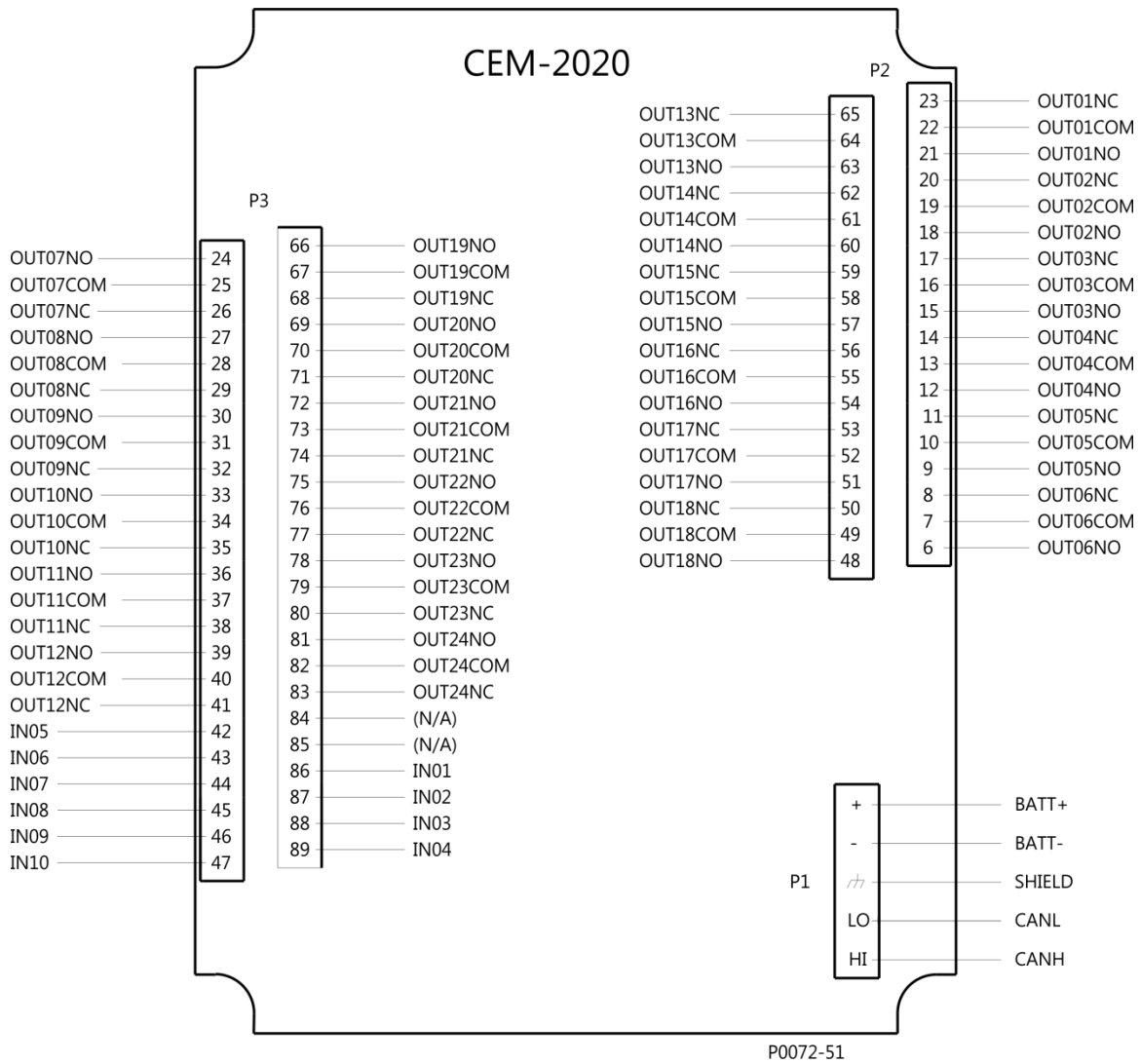

Figure 2-3. CEM-2020 Contact Input and Contact Output Terminals

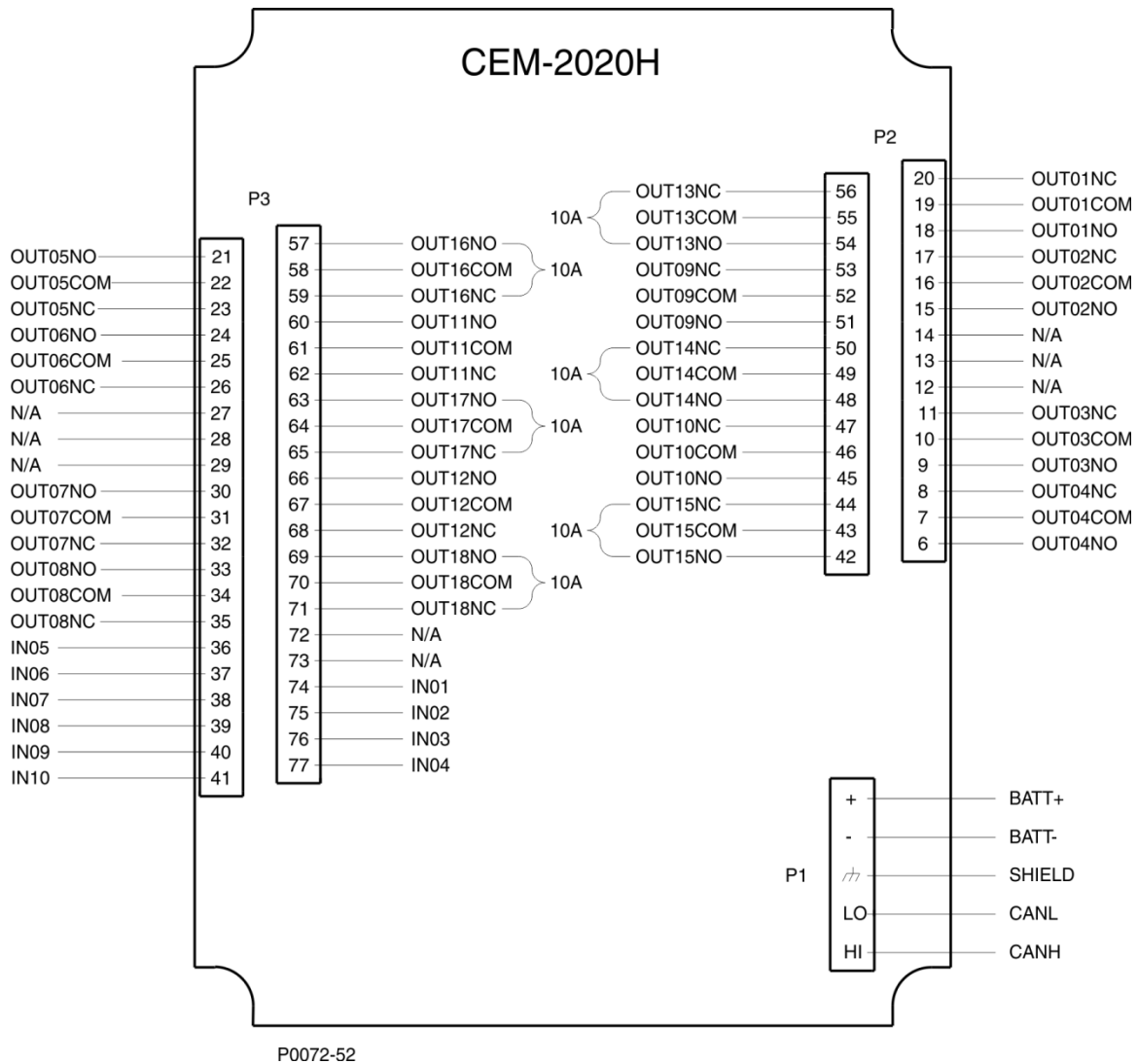

Figure 2-4. CEM-2020H Contact Input and Contact Output Terminals

CAN Interface

These terminals provide communication using the SAE J1939 protocol and provide high-speed communication between the Contact Expansion Module and the DGC-2020HD. Connections between the CEM-2020 and DGC-2020HD should be made with twisted-pair, shielded cable. CAN interface terminals are listed in Table 2-2. Refer to Figure 2-11 and Figure 2-12.

Table 2-2. CAN Interface Terminals

Terminal	Description
P1- HI (CAN H)	CAN high connection (yellow wire)
P1- LO (CAN L)	CAN low connection (green wire)
P1- (SHIELD)	CAN drain connection

Notes

1. If the CEM-2020 is providing one end of the J1939 bus, a 120 Ω , ½ watt terminating resistor should be installed across terminals P1- LO (CANL) and P1- HI (CANH).
2. If the CEM-2020 is not part of the J1939 bus, the stub connecting the CEM-2020 to the bus should not exceed 914 mm (3 ft) in length.
3. The maximum bus length, not including stubs, is 40 m (131 ft).
4. The J1939 drain (shield) should be grounded at one point only. If grounded elsewhere, do not connect the drain to the CEM-2020.

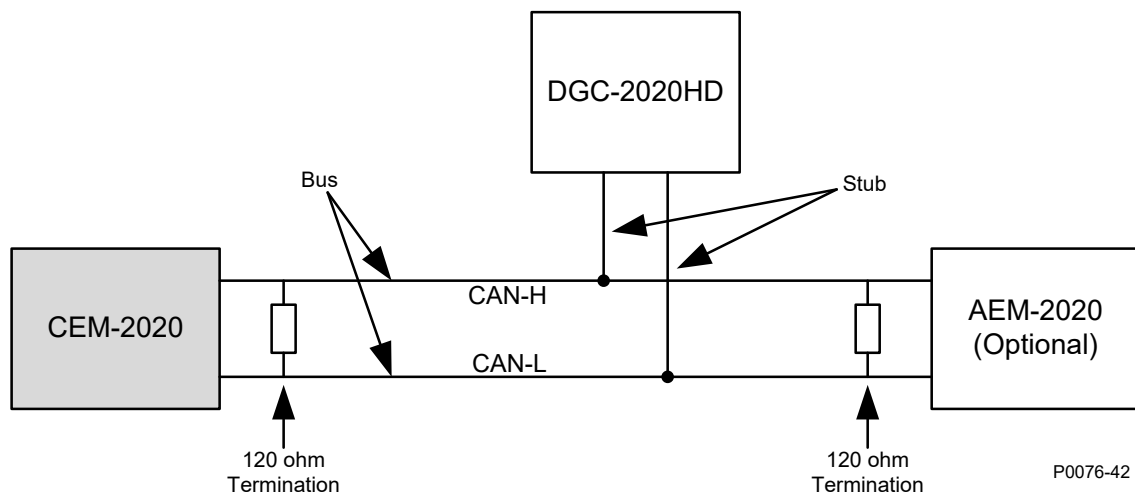

Figure 2-5. CAN Interface with CEM-2020 providing One End of the Bus

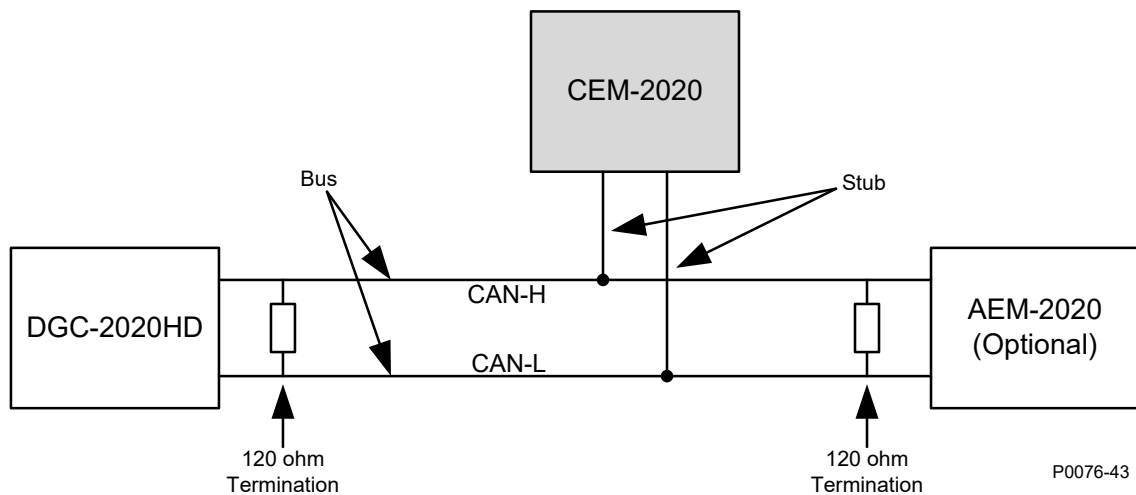

Figure 2-6. CAN Interface with DGC-2020HD providing One End of the Bus

CEM-2020 Configuration

CEM-2020s are enabled on the Remote Module Setup screen in BESTCOMSPi[®]. If more than one CEM-2020 is connected, the serial number of each module must be entered. A CEM Not Configured pre-alarm will occur if the expected serial number does not match the serial number detected on the General Settings, Device Info screen. The Remote Module Setup screen is illustrated in Figure 2-13.

Figure 2-7. Settings Explorer, System Parameters, Remote Module Setup

Remote Contact Inputs Configuration

Ten remote contact inputs provide additional sensing. The ten, identical inputs are designated CEM x Input #1 through CEM x Input #10 (where x = 1 to 4). Contact input logic connections are made on the BESTlogicPlus screen in BESTCOMSPlus and contact input operational settings are configured on the CEM x Inputs (where x = 1 to 4) settings screen in BESTCOMSPlus.

BESTCOMSPlus Navigation Path: Settings Explorer, Programmable Inputs, Remote Contact Inputs

Front Panel Navigation Path: Settings Explorer > Programmable Inputs > Remote Contact Inputs

Input Setup

Alarm Configuration

When the input senses a closed contact, one of the following occurs depending on the Alarm Configuration setting. Alarm configurations are described in the *Reporting and Alarms* chapter in the *Operation* manual. By default, all inputs are configured for Status Only.

Activation Delay

A user-adjustable time delay can be set to delay recognition of a contact input.

Label Text

In order to make identification of the remote contact inputs easier, each of the inputs can be given a user-assigned label. The label is an alphanumeric string with a maximum of 16 characters.

Contact Recognition

Contacts can be recognized always or only while the engine is running.

Logic Connections

Remote contact input logic connections are made on the BESTlogicPlus screen in BESTCOMSPlus. The CEM 1 Input 1 logic block is illustrated in Figure 2-14. The output is true when the CEM-2020 senses a contact closure and after the activation delay expires. The alarm and pre-alarm logic blocks are similar.

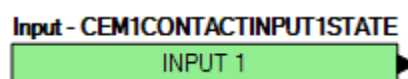

Figure 2-8. Remote Contact Input Logic Block

Operational Settings

Remote contact input operational settings are configured on the CEM x Inputs (where x = 1 to 4) settings screen (Figure 2-15) in *BESTCOMSPi.us*.

The screenshot displays the 'CEM 1 Inputs' configuration screen. It is organized into six columns, each representing an input from Input #01 to Input #06. Each column contains the following settings:

- Input #01:** Alarm Configuration: Status Only; Activation Delay (s): 0; Label Text: CEM1 Input 1; Contact Recognition: Always; Contact Type: Normally Open.
- Input #02:** Alarm Configuration: Status Only; Activation Delay (s): 0; Label Text: CEM1 Input 2; Contact Recognition: Always; Contact Type: Normally Open.
- Input #03:** Alarm Configuration: Status Only; Activation Delay (s): 0; Label Text: CEM1 Input 3; Contact Recognition: Always; Contact Type: Normally Open.
- Input #04:** Alarm Configuration: Status Only; Activation Delay (s): 0; Label Text: CEM1 Input 4; Contact Recognition: Always; Contact Type: Normally Open.
- Input #05:** Alarm Configuration: Status Only; Activation Delay (s): 0; Label Text: CEM1 Input 5; Contact Recognition: Always; Contact Type: Normally Open.
- Input #06:** Alarm Configuration: Status Only; Activation Delay (s): 0; Label Text: CEM1 Input 6; Contact Recognition: Always; Contact Type: Normally Open.

Figure 2-9. Settings Explorer, Programmable Inputs, Remote Contact Inputs, CEM 1 Inputs

Remote Contact Outputs Configuration

A CEM-2020 provides 24 contact outputs and a CEM-2020H provides 18 contact outputs. The outputs are designated CEM x Output #1 through CEM x Output #24 (where x = 1 to 4). Contact output logic connections are made on the *BESTlogicPlus* screen in *BESTCOMSPi.us* and contact output operational settings are configured on the CEM x Outputs (where x = 1 to 4) settings screen in *BESTCOMSPi.us*.

BESTCOMSPi.us Navigation Path: Settings Explorer, Programmable Outputs, Remote Contact Outputs

Front Panel Navigation Path: Settings Explorer > Programmable Outputs > Remote Contact Outputs

Label Text

In order to make identification of the remote contact outputs easier, each of the outputs can be given a user-assigned label. The label is an alphanumeric string with a maximum of 16 characters.

Logic Connections

Remote contact output logic connections are made on the *BESTlogicPlus* screen in *BESTCOMSPi.us*. The CEM 1 Output 1 logic block is illustrated in Figure 2-16.

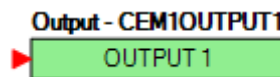

Figure 2-10. Remote Contact Output Logic Block

Operational Settings

Remote contact output labels are configured on the CEM x Outputs (where x = 1 to 4) settings screen (Figure 2-17) in *BESTCOMSPi.us*.

CEM 1 Outputs

Output #1 Label Text CEM1 Output 1	Output #2 Label Text CEM1 Output 2	Output #3 Label Text CEM1 Output 3
Output #4 Label Text CEM1 Output 4	Output #5 Label Text CEM1 Output 5	Output #6 Label Text CEM1 Output 6
Output #7 Label Text CEM1 Output 7	Output #8 Label Text CEM1 Output 8	Output #9 Label Text CEM1 Output 9
Output #10 Label Text CEM1 Output 10	Output #11 Label Text CEM1 Output 11	Output #12 Label Text CEM1 Output 12

Figure 2-11. Settings Explorer, Programmable Outputs, Remote Contact Outputs, CEM 1 Outputs

Firmware Updates

Refer to the *Device Information* chapter in the *Configuration* manual for information on upgrading firmware in the CEM-2020.

Repair

Contact Expansion Modules are manufactured using state-of-the-art surface-mount technology. As such, Basler Electric recommends that no repair procedures be attempted by anyone other than Basler Electric personnel.

Before returning the CEM-2020 for repair, contact Basler Electric Technical Services Department at 618-654-2341 for a return authorization number.

Maintenance

Preventive maintenance consists of periodically checking that the connections between the CEM-2020 and the system are clean and tight.

Storage

This device contains long-life aluminum electrolytic capacitors. For devices that are not in service (spares in storage), the life of these capacitors can be maximized by energizing the device for 30 minutes once per year.

3 • VRM-2020

The Voltage Regulation Module (VRM-2020) is an optional remote device that communicates with the DGC-2020HD and provides excitation to the field of a brushless exciter.

Features

VRM-2020s have the following standard features:

- Five pre-position setpoints for each control mode
- Internal tracking between AVR and FCR operating mode setpoints
- PID stability group with Auto Tune feature
- Real-time metering of field voltage and current
- Soft start and voltage buildup control
- Three limiting functions:
 - Overexcitation: summing point and takeover
 - Underexcitation
 - Underfrequency and V/Hz limiting
- Communications via controller area network (CAN)

Optional Features

A part number defines the options and characteristics in a specific VRM-2020 and appears on a label affixed to the device. Table 3-1 lists the features and capabilities for each part number.

Table 3-1. VRM-2020 Part Numbers

Part Number	Operating Power Configuration	Output Current	Crowbar Circuit	Eight RTD Inputs and Exciter Diode Monitor
9503800101	Single-phase PMG	3.5 Adc	No	No
9503800102	Single-phase PMG	3.5 Adc	Yes	No
9503800104	Single-phase PMG	3.5 Adc	Yes	Yes

Crowbar Circuit

The Crowbar Circuit protects the generator field from overcurrent damage resulting from a shorted VRM-2020 power switch. During operation, if the field voltage exceeds a setpoint and the power stage receives no gating pulses for 1.5 seconds, the Crowbar Circuit activates and places a short-circuit across the VRM-2020 operating power terminals. This protects the generator by blowing the operating power fuse and removing operating power from the device. The crowbar circuit should be used only when the VRM-2020 derives operating power from a PMG.

RTD Inputs

Eight remote RTD inputs provide metering of winding or bearing temperatures. An element can be configured to trip when the metered input increases above or decreases below the user-defined threshold. When a trip occurs, different actions may be performed depending on the alarm configuration setting for each RTD input.

Exciter Diode Monitor

The VRM-2020 monitors the rms ripple of the exciter field current. If it exceeds the diode fault threshold setpoint for the duration of the time delay, a diode fault occurs. When a diode fault occurs, different actions may be performed depending on the alarm configuration setting.

Specifications

Operating Power

Configuration	Single-phase, PMG only
Voltage Range	150 to 300 Vac
Frequency Range	50 to 300 Hz
Input Burden	517 VA (at 3.5 Adc excitation output)
THD (total harmonic distortion)	40%

Control Power

Nominal	12 or 24 Vdc
Range	6 to 32 Vdc
Burden	1 W (at 32 Vdc)

Field Output

Continuous Rating	63 Vdc, 3.5 Adc
Forcing Rating	Up to 120 Vdc at 7.5 Adc for 10 seconds

Field Voltage and Current Metering

Range	0 to 120 Vdc for 63 Vdc nominal output
Accuracy	±3% of nominal field output rating over the operating temperature range

Regulation

Voltage Regulation Accuracy	±0.25% from no load to full load
-----------------------------------	----------------------------------

Automatic Voltage Regulation (Auto) Mode

Adjustment Range	1 to 999,999 Vac
Increment	0.1 Vac

Field Current Regulation (Manual) Mode

Adjustment Range	0 Adc to 3.5 Adc (continuous)
Increment	0.01 Adc

Parallel Compensation Modes

Modes	Reactive Droop, Line Drop, and Reactive Differential (Cross-Current)
Cross-current Input Burden	< 5 VA with 1 A CT or < 10 VA with 5 A CT

Setpoint Range

Reactive Droop	0 to 30% of rated generator voltage
Increment	0.1%
Line Drop	0 to 30% of rated generator voltage
Increment	0.1%
Cross-Current	-30% to +30% of primary CT current
Increment	0.01%

RTD Inputs (Optional)

The VRM-2020 (Part Number 9508300104) contains eight programmable RTD inputs.

Rating	100 Ω platinum or 10 Ω copper (selectable in BESTCOMSP ^{Plus} ®)
Setting Range	-58 to +482°F (-50 to +250°C)
Accuracy (10 Ω copper)	±0.078 Ω at 25°C ambient, ±0.008 Ω/°C drift over the ambient operating temperature range
Accuracy (100 Ω platinum)	±0.757 Ω at 25°C ambient, ±0.055 Ω/°C drift over the ambient operating temperature range

CAN Interface

Differential Bus Voltage.....	1.5 to 3 Vdc
Maximum Voltage	-32 to +32 Vdc with respect to negative battery terminal
Communication Rate.....	125 or 250 kbps

Type Tests

Shock

Withstands 15 G in three perpendicular planes.

Vibration

3 to 25 Hz at 0.063 inches (1.6 mm), peak amplitude
25 to 2,000 Hz at 5 G

Humidity

IEC 60068-2-78

Salt Fog

IEC 68-2-52, level 2 severity

RF Immunity

Tested in close proximity to an unshielded, unsuppressed Altronic DISN 800 Spark Ignition System and a Nissan Engine Distributor.

HALT (Highly Accelerated Life Testing)

HALT is used by Basler Electric to ensure that our products provide the user with many years of reliable service. HALT subjects the device to extremes in temperature, shock, and vibration to simulate years of operation, but in a much shorter period. HALT allows Basler Electric to evaluate all possible design elements that will add to the life of this device. As an example of some of the extreme testing conditions, the VRM-2020 was subjected to temperature tests (over a temperature range of -90 to +120°C (-130 to +248°F)), vibration tests (5 to 50 G at +20°C (68°F)), and temperature/vibration tests (tested at 50 G over a temperature range of -80 to +110°C (-112 to +230°F)). Combined temperature and vibration testing at these extremes proves that the VRM-2020 is expected to provide long-term operation in a rugged environment. Note that the vibration and temperature extremes listed in this paragraph are specific to HALT and do not reflect recommended operation levels.

Environment

Temperature

Operating.....	-40 to 158°F (-40 to 70°C)
Storage.....	-40 to 185°F (-40 to 85°C)

Regulatory Standards

UL Approval

The VRM-2020 is certified to applicable Canadian and US safety standards.

Standards used for evaluation:

- UL6200
- CSA C22.2 No. 0
- CSA C22.2 No. 14

CE Compliance

This product has been evaluated and complies with the relevant essential requirements set forth by the EU legislation.

EU Directives:

- Low Voltage Devices (LVD) - 2014/35/EU
- Electromagnetic Compatibility (EMC) - 2014/30/EU
- RoHS2 - 2011/65/EU

Applicable standards used:

- IEC 62103:2003 - Electronic Equipment for use in Power Installations (pertinent EMC sections)
- EN 62477-1:2012 - Safety Requirements for Power Electronic Converter Systems and Equipment Part 1: General
- EN 61000-6-2:2005 - Electromagnetic Compatibility (EMC) - Part 6-2: Generic Standards, Immunity for Industrial Environments
- EN 61000-6-4:2007; with AMD 1:2011 - Electromagnetic Compatibility (EMC) - Part 6-4: Generic Standards, Emission Standard for Industrial Environments.

FCC Requirements

This product complies with FCC 47 CFR Part 15.

NFPA Compliance

Complies with NFPA Standard 110, *Standard for Emergency and Standby Power*

Maritime Recognition

American Bureau of Shipping (ABS) – For current certificates, see www.basler.com.

China RoHS

The following table serves as the declaration of hazardous substances for China in accordance with PRC standard SJ/T 11364-2014. The EFUP (Environment Friendly Use Period) for this product is 40 years.

PRODUCT: VRM-2020										
有害物质 Hazardous Substances										
零件名称 Part Name	铅 Lead (Pb)	汞 Mercury (Hg)	镉 Cadmium (Cd)	六价铬 Hexavalent Chromium (Cr ⁶⁺)	多溴联苯 Polybrominated Biphenyls (PBB)	多溴二苯醚 Polybrominated Diphenyl Ethers (PBDE)	邻苯二甲酸二丁酯 Dibutyl Phthalate (DBP)	邻苯二甲酸丁苄酯 Benzyl butyl phthalate (BBP)	邻苯二甲酸二酯 Bis(2-ethylhexyl) phthalate (BEHP)	邻苯二甲酸二异丁酯 Diisobutyl phthalate (DIBP)
金属零件 Metal parts	○	○	○	○	○	○	○	○	○	○
聚合物 Polymers	○	○	○	○	○	○	○	○	○	○
电子产品 Electronics	X	○	○	○	○	○	○	○	○	○
电缆和互连配件 Cables & interconnect accessories	○	○	○	○	○	○	○	○	○	○
绝缘材料 Insulation material	○	○	○	○	○	○	○	○	○	○

本表格依据 SJ/T11364 的规定编制。

O: 表示该有害物质在该部件所有均质材料中的含量均在 GB/T 26572 规定的限量要求以下。

X: 表示该有害物质至少在该部件的某一均质材料中的含量超出 GB/T 26572 规定的限量要求。

This form was prepared according to the provisions of standard SJ/T11364.

O: Indicates that the hazardous substance content in all homogenous materials of this part is below the limit specified in standard GB/T 26252.

X: Indicates that the hazardous substance content in at least one of the homogenous materials of this part exceeds the limit specified in standard GB/T 26572.

Physical

Weight 1.05 lb (0.476 kg)

Dimensions See *Mounting* below.

Mounting

VRM-2020s are delivered in sturdy cartons to prevent shipping damage. Upon receipt of a module, check the part number against the requisition and packing list for agreement. Inspect for damage, and if there is evidence of such, immediately file a claim with the carrier and notify the Basler Electric regional sales office, your sales representative, or a sales representative at Basler Electric, Highland, Illinois USA.

If the device is not installed immediately, store it in the original shipping package in a moisture- and dust-free environment.

VRM-2020s are contained in a potted plastic case and may be mounted in any convenient position. The construction of a VRM-2020 is durable enough to mount directly on a genset using size 12 hardware. The torque applied to the size 12 mounting hardware should not exceed 41 in-lb (4.6 N•m).

See Figure 3-1 for VRM-2020 overall dimensions. All dimensions are shown in inches with millimeters in parenthesis.

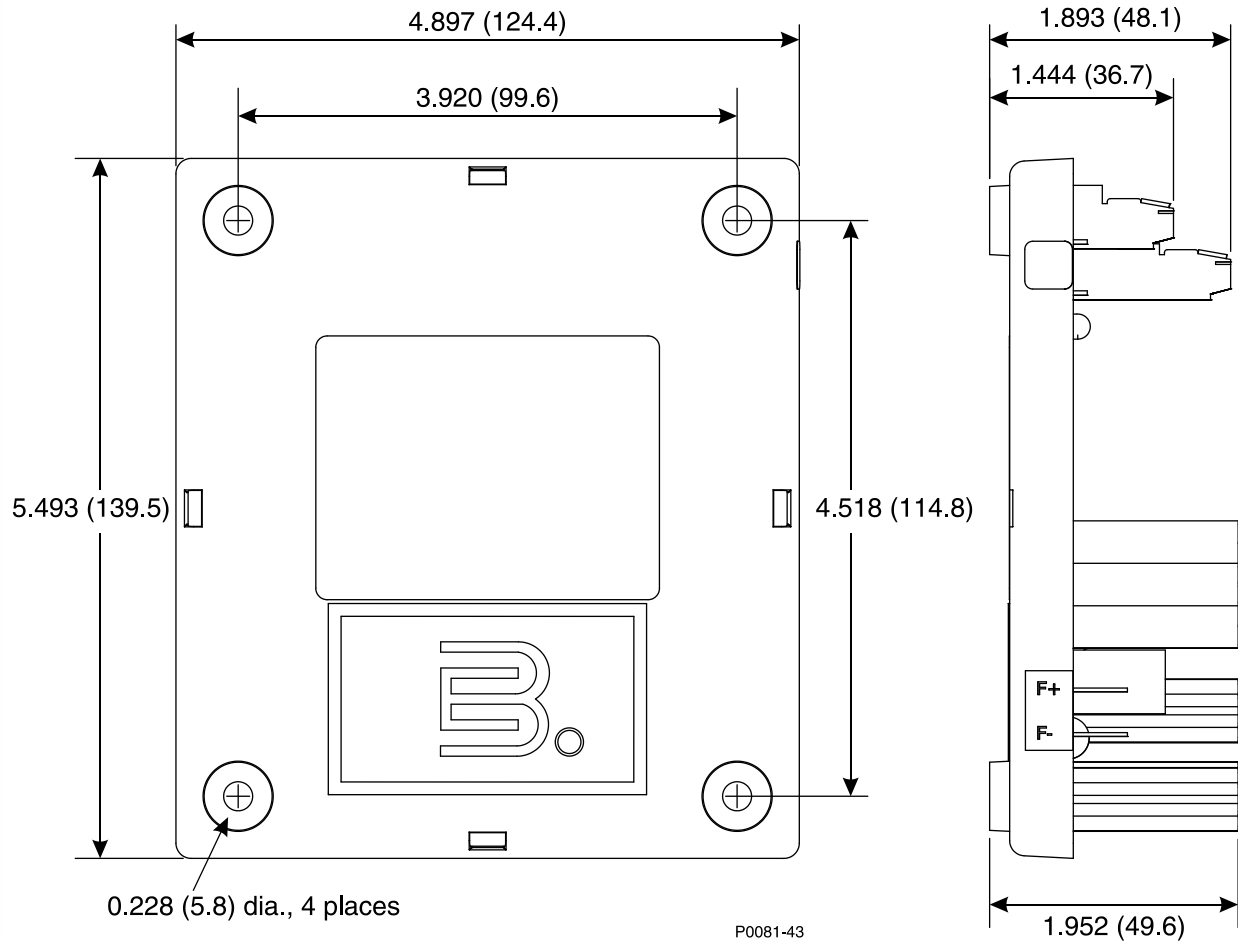

Figure 3-1. VRM-2020 Overall Dimensions

Terminals and Connectors

VRM-2020 connections are dependent on the application. Incorrect wiring may result in damage to the module.

Notes

Control power from the battery must be of the correct polarity. While reverse polarity will not cause damage, the VRM-2020 will not operate.

Be sure that the VRM-2020 is hard-wired to earth ground with no smaller than 12 AWG copper wire attached to the chassis ground terminal on the module.

It is recommended to minimize the vibration load on the connector plug by ensuring that wires are well-constrained, with no more than 6 to 8 inches of unconstrained wire length near the connector plugs.

Terminations

The terminal interface consists of compression terminals and quarter-inch, male, quick-connect terminals. VRM-2020 connections are made with two 12-position connectors, one 3-position connector, and seven quarter-inch, male, quick-connect terminals.

All VRM-2020 terminals are located on the primary (component) side and their locations are illustrated in Figure 3-2. Connector screw terminals accept a maximum wire size of 12 AWG. Maximum screw torque is 3.5 to 4.4 in-lb (0.395 to 0.497 N•m). Recommended wire strip length is 0.236 to 0.276 inches (6-7 mm). Quick-connect terminals accept a maximum wire size of 12 AWG. All terminals are tin-plated.

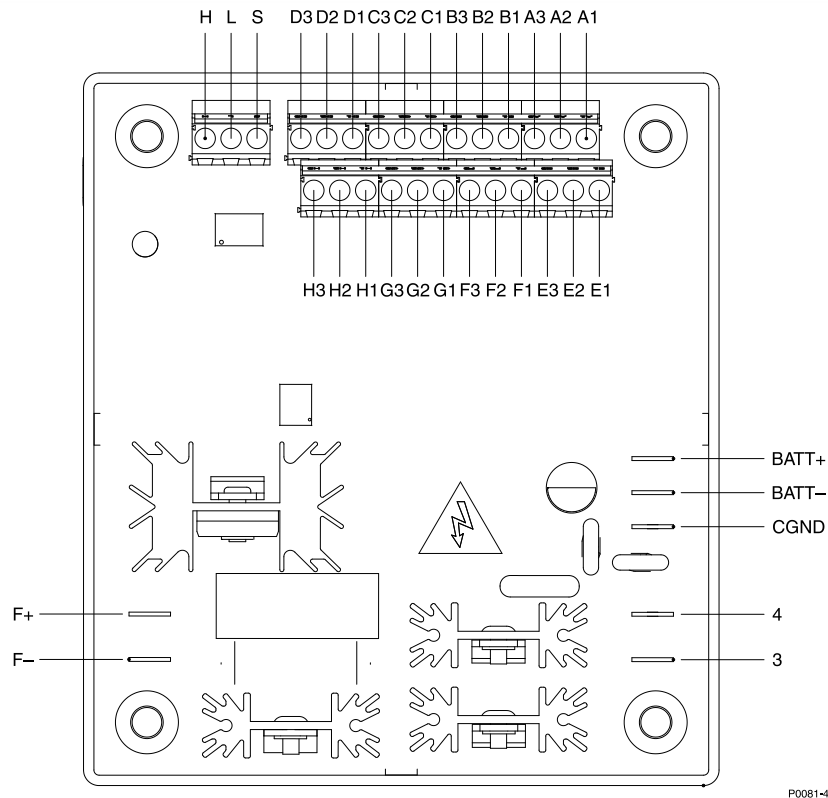

Figure 3-2. VRM-2020 Terminals and Connectors

Operating power

Operating power terminals accept 150 to 300 Vac from a single-phase PMG. Operating power terminals are listed in Table 3-2.

It is required that a 5 A fuse be added for additional protection in line with the wiring to the power input of the VRM-2020. The fuse shall be rated for 300 V (at a minimum).

Table 3-2. Operating power Terminals

Terminal	Description
3	A-phase
4	B-phase

Control power

The VRM-2020 control power terminals accept 12 or 24 Vdc and tolerate voltage over the range of 6 to 32 Vdc. Control power must be of the correct polarity. While reverse polarity will not cause damage, the VRM-2020 will not operate. Control power terminals are listed in Table 3-3.

It is required that a 5 A fuse be added for additional protection in line with the wiring to the battery input of the VRM-2020. The fuse shall be rated for 32 Vdc (at a minimum).

Table 3-3. Control power Terminals

Terminal	Description
CGND	Chassis ground connection
BATT-	Negative side of Control power input
BATT+	Positive side of Control power input

Field Output

Excitation power is supplied to the field through these terminals. See Table 3-4.

Table 3-4. Field Output Terminals

Terminal	Description
F+	Positive side of field
F-	Negative side of field

CAN Communication

These terminals provide communication using the SAE J1939 protocol and provide high-speed communication between the DGC-2020HD and VRM-2020. Connections between the VRM-2020 and DGC-2020HD should be made with twisted-pair, shielded cable. CAN interface terminals are listed in Table 3-5. For typical CAN connections, refer to *Connections*, *CAN Interface* below, and the *Typical Applications* chapter in the *Installation* manual.

Table 3-5. CAN Terminals

Terminal	Description
H	CAN high connection
L	CAN low connection
S	CAN drain (shield) connection

RTD Inputs

These terminals accept two- or three-wire, 10 Ω copper or 100 Ω platinum RTD inputs. Table 3-6 lists the terminals which correspond to each of the eight RTD inputs.

Table 3-6. RTD Input Terminals

Terminal	Description
A1, A2, A3	RTD Input #1 connections
B1, B2, B3	RTD Input #2 connections
C1, C2, C3	RTD Input #3 connections
D1, D2, D3	RTD Input #4 connections
E1, E2, E3	RTD Input #5 connections
F1, F2, F3	RTD Input #6 connections
G1, G2, G3	RTD Input #7 connections
H1, H2, H3	RTD Input #8 connections

Connections

Typical VRM-2020 connections are shown in Figure 3-3.

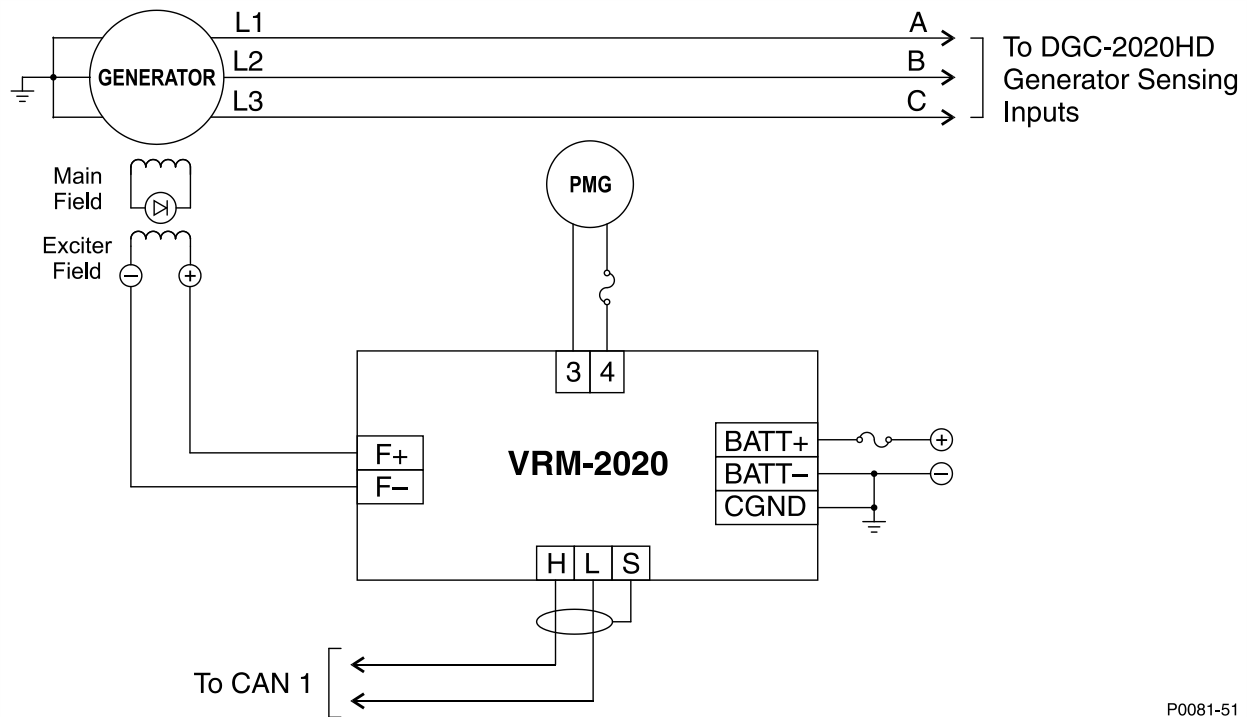

P0081-51

Figure 3-3. VRM-2020 Typical Connections

External RTD Input Connections

External two-wire RTD input connections are shown in Figure 3-4 and external three-wire RTD input connections are shown in Figure 3-5.

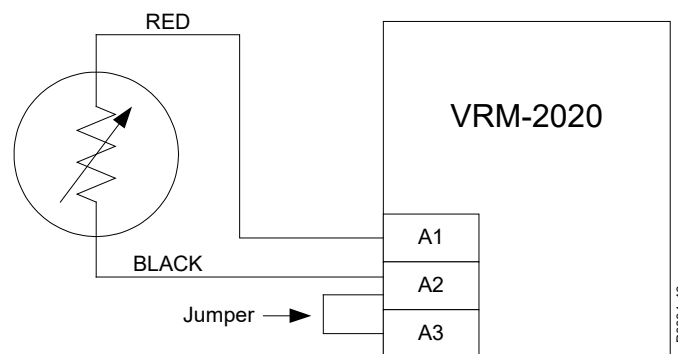

Figure 3-4. Two-Wire RTD Connections

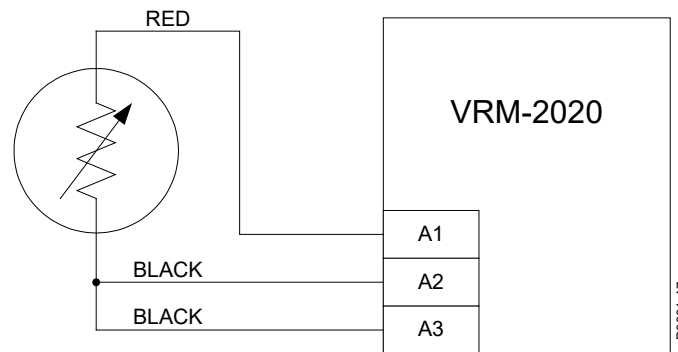

Figure 3-5. Three-Wire RTD Connections

CAN Interface

Figure 3-6 illustrates CAN interface connections with the VRM-200 providing one end of the bus. Figure 3-7 illustrates CAN interface connections with the DGC-2020HD providing one end of the bus.

Note

1. If the VRM-200 is providing one end of the J1939 bus, a 120 Ω , ½ watt terminating resistor should be installed across terminals L and H.
2. If the VRM-200 is not part of the J1939 bus, the stub connecting the VRM-200 to the bus should not exceed 914 mm (3 ft) in length.
3. The maximum bus length, not including stubs, is 40 m (131 ft).
4. The J1939 drain (shield) should be grounded at one point only. If grounded elsewhere, do not connect the drain to the VRM-200.
5. It is recommended to upgrade the firmware in all AEM-2020s and CEM-2020s that share a CAN Bus network with a VRM-200. Upgrade CEM-2020s to firmware version 1.01.05 or later. Upgrade AEM-2020s to firmware version 1.00.06 or later.

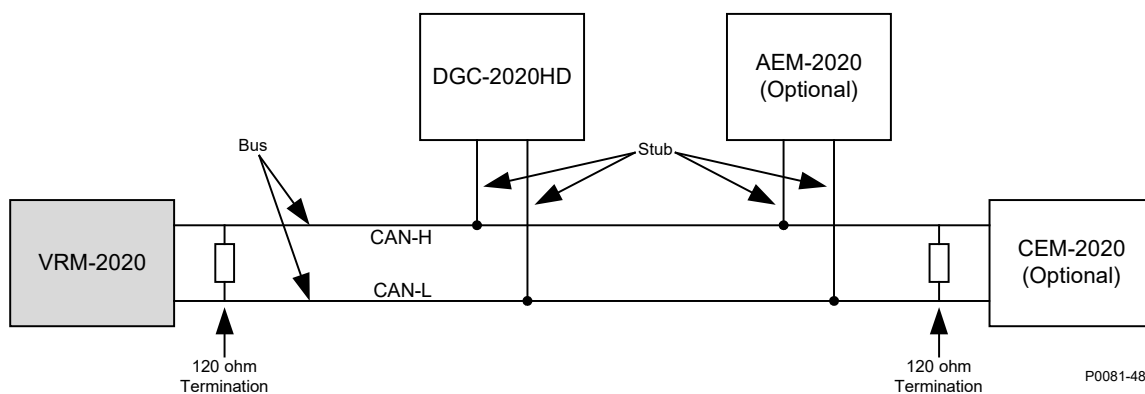

Figure 3-6. CAN Interface with VRM-200 Providing One End of the Bus

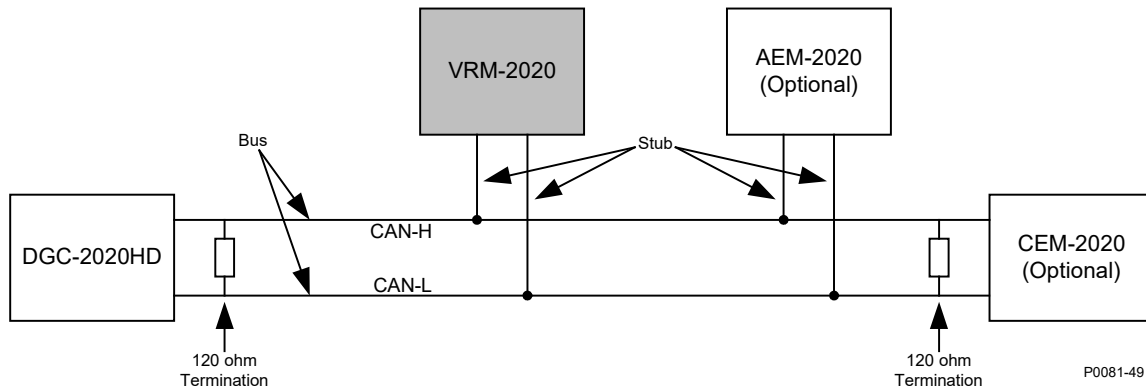

Figure 3-7. CAN Interface with DGC-2020HD Providing One End of the Bus

Cross-current Compensation

Cross-current compensation (reactive differential) mode allows two or more paralleled generators to share a common reactive load. As shown in Figure 3-8, each generator is regulated by a VRM-2020. The DGC-2020HD uses an auxiliary CT input (terminals AUX I1+ and AUX I1-) and a dedicated, external current transformer (CT) to sense generator current. The DGC-2020HD passes the current sensing information to the VRM-2020 via CAN communication. The resistors shown in Figure 3-8 are used to set the burden and may be adjusted to suit the application. Ensure that the power rating of the resistors is adequate for the application. The auxiliary CT input terminals shown in Figure 3-8 are for auxiliary CT input #1, but any of the four auxiliary CT inputs can be configured for cross-current compensation.

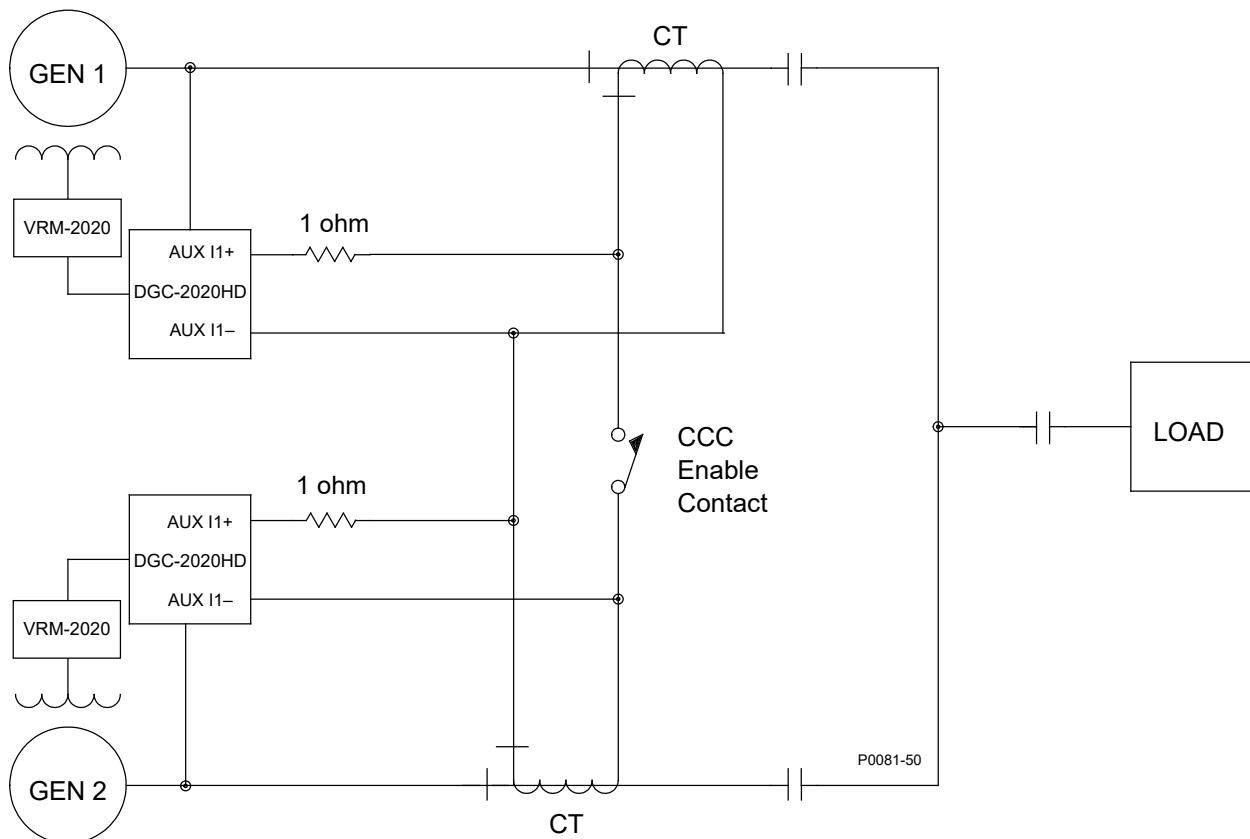

Figure 3-8. Connections for Cross-Current Compensation

Power Inputs

Power is applied to two separate inputs: control power and operating power. The control power supplies power to an internal power supply for protection and control functions. The power stage uses the operating power input as the source for the converted excitation power that it applies to the field.

Control power

The VRM-2020 accepts 12 or 24 Vdc (6 to 32 Vdc) control power at terminals BATT+ and BATT-. A red LED on the VRM-2020 flashes to indicate that the VRM-2020 is powered up and functioning properly. The LED lights solid during power up. When the power-up sequence is complete, this LED flashes. If the LED does not flash after power up, contact Basler Electric.

Operating power

Operating power from a PMG is applied at terminals 3 and 4. To achieve 63 Vdc excitation output, 150 to 300 Vac (single-phase) must be applied. The operating power frequency range for the VRM-2020 is 50 to 300 hertz.

Power Stage

The power stage receives operating power and supplies regulated dc excitation power to the field of a brushless exciter. Excitation power is supplied at terminals F+ and F-. The amount of power supplied to the exciter field is based on gating pulses received from the microprocessor. The power stage uses a solid-state power switch to provide the required power to the exciter field. Power stage output to the field is rated up to 63 Vdc at 3.5 Adc continuous and 120 Vdc at 7.5 Adc for 10 seconds.

Regulation

The VRM-2020 receives control signals from the DGC-2020HD to supply excitation power. Stable regulation is enhanced by the automatic tracking of the active-mode setpoint by the inactive regulation mode. Pre-position setpoints within each regulation mode enable the VRM-2020 to be utilized for multiple system and application needs.

Regulation Modes

The DGC-2020HD uses automatic voltage regulation (AVR) and field current regulation (FCR/manual) modes to regulate generator output through the VRM-2020.

Automatic Voltage Regulation Mode

In AVR mode, the DGC-2020HD regulates generator output voltage. This is accomplished by sensing generator output voltage and adjusting dc output excitation current to maintain voltage at the regulation setpoint. The regulation setpoint may be adjusted by Raise and Lower commands, analog biases, and five pre-positions. The regulation point may also be modified by limiters and AVR control modes under certain conditions.

Field Current Regulation Mode

In FCR mode, the DGC-2020HD maintains dc excitation current at a set level. The current-level setpoint is adjustable from 0 to 3.5 Adc. The regulation setpoint may be adjusted by Raise and Lower commands, analog biases, and five pre-positions.

In FCR mode, the VRM-2020 and DGC-2020HD regulate the level of excitation power supplied to the field independently of all operating conditions. The operator must manually vary the FCR setpoint in order to achieve the desired operating conditions.

Parallel Compensation

With the VRM-2020, the DGC-2020HD can control the excitation level of two or more generators operating in parallel so that the generators share the reactive load. The DGC-2020HD can employ line drop compensation, droop compensation, cross-current compensation (reactive differential), or Ethernet var sharing schemes for reactive load sharing.

Auto Tracking

The DGC-2020HD provides internal setpoint tracking for AVR and FCR regulation modes. When enabled, the inactive regulation mode automatically tracks the active regulation mode.

If a loss of sensing condition occurs while the excitation system is operating online, a transfer to FCR mode may be triggered. With Auto Tracking enabled, the impact on the excitation level is minimized during the mode transfer.

Limiters

Limiters ensure that the controlled machine does not exceed its capabilities. Overexcitation and underexcitation are limited by the DGC-2020HD. It also limits the generator voltage during underfrequency conditions.

Overexcitation

Operating in the overexcited region of a generator's capability curve can cause excessive field current and field winding heating. The overexcitation limiter (OEL) monitors the level of field current supplied by the VRM-2020 and limits it to prevent field overheating.

The OEL can be enabled in all regulation modes. OEL behavior in manual mode can be configured to limit excitation or issue an alarm. This behavior is configured in BESTlogic™ *Plus*.

Two styles of overexcitation limiting are available: Summing Point or Takeover. These are described under *Configuration, Overexcitation Limiter* below.

Underexcitation

Operating a generator in an underexcited condition can cause the stator end iron to overheat. Extreme underexcitation may lead to a loss of synchronism. The underexcitation limiter (UEL) senses the leading var level of the generator and limits decreases in excitation to limit end-iron heating. When enabled, the UEL operates in all regulation modes. UEL behavior in manual mode can be configured to limit excitation or issue an alarm. This behavior is configured in BESTlogic *Plus*.

Underfrequency and V/Hz Limiting

The underfrequency limiter is selectable for underfrequency limiting or volts per hertz limiting. These limiters protect the generator from damage due to excessive magnetic flux resulting from low frequency and/or overvoltage.

Metering

The VRM-2020 meters its field voltage and current output. This information is passed to the DGC-2020HD via CAN communication.

CAN Communication

A CAN is a standard interface that enables communication between the VRM-2020 and the DGC-2020HD.

Configuration

The VRM-2020 is enabled on the Remote Module Setup screen in *BESTCOMSPi.us*. The Remote Module Setup screen is illustrated in Figure 3-9.

Figure 3-9. Settings Explorer, System Parameters, Remote Module Setup

Style Number

The model number, together with the style number, describes the options included in a specific device. The style number of the VRM-2020 is displayed on the *BESTCOMSPi.us* VRM Settings, Style Number screen after downloading settings from the device. When configuring VRM-2020 settings off-line, the style number for the unit to be configured can be entered into *BESTCOMSPi.us* to enable configuration of the required settings. The *BESTCOMSPi.us* VRM Settings, Style Number screen is illustrated in Figure 3-10.

Option	Option Name	Setting 1	Setting 2
1	Power Input	1) Single Phase	
A	Field Output	A) 3.5 Adc	
1	RTD	0) None	
		1) RTD	
E	Diode Monitor	N) None	
		E) EDM	
1	Crowbar	0) None	
		1) Crowbar	

Figure 3-10. Settings Explorer, VRM Settings, Style Number

Field Rated Data

For proper excitation control and protection, the DGC-2020HD must be configured with the ratings of the field. Required field ratings include the no-load dc voltage and current and full-load voltage and current.

BESTCOMSPi.us Navigation Path: Settings Explorer, VRM Settings, Field Rated Data

Front Panel Navigation Path: Settings Explorer > VRM Control Settings > Field Rated Data

Operational Settings

The BESTCOMSPPlus Field Rated Data settings screen is illustrated in Figure 3-11.

Field Rated Data	
Field Rated Data	
Voltage - Full Load (V)	Voltage - No Load (V)
63.0	32.0
Current - Full Load (A)	Current - No Load (A)
1.00	1.00

Figure 3-11. Settings Explorer, VRM Settings, Field Rated Data

Startup

During startup, the soft start function prevents voltage overshoot by controlling the rate of generator terminal voltage buildup (toward the setpoint). Soft start is active in AVR and FCR regulation modes. Soft start behavior is based on two parameters: level and time. The soft start level is expressed as a percentage of the nominal generator terminal voltage and determines the starting point for generator voltage buildup during startup. The Soft Start Time setting defines the amount of time allowed for the buildup of generator voltage during startup.

BESTCOMSPPlus Navigation Path: Settings Explorer, VRM Settings, Startup

Front Panel Navigation Path: Settings Explorer > VRM Control Settings > Startup

Operational Settings

The BESTCOMSPPlus Startup settings screen is illustrated in Figure 3-12.

Startup	
Soft Start Level (%)	
5.0	
Soft Start Time (s)	
5	

Figure 3-12. Settings Explorer, VRM Settings, Startup

AVR Mode Configuration

BESTCOMSPPlus Navigation Path: Settings Explorer, VRM Settings, AVR Configuration

Front Panel Navigation Path: Settings Explorer > VRM Control Settings > AVR

Setpoints

When operating in AVR (Automatic Voltage Regulation) mode, the DGC-2020HD regulates the excitation level in order to maintain the generator terminal voltage setpoint despite changes in load and operating conditions. AVR setpoint adjustment is made through:

- Application of contacts at DGC-2020HD contact inputs configured for raising and lowering the active setpoint;
- Application of an analog control signal at DGC-2020HD an analog input configured for biasing the active setpoint;
- The BESTCOMSPPlus VRM Control Panel screen (available in the BESTCOMSPPlus Metering Explorer); or
- A raise or lower command transmitted through the DGC-2020HD Modbus port.

The range of adjustment is defined by Minimum and Maximum settings that are expressed as a percentage of the rated generator voltage. The Adjust Rate is the rate, in percent of rated voltage per second, which the generator setpoint increases or decreases in response to raise/lower requests.

Pre-Positions

Each regulation mode has five pre-position setpoints which allow the VRM-2020 to be utilized for multiple system and application needs. Each pre-position setpoint can be assigned to a programmable contact input on the DGC-2020HD. When the appropriate contact input is closed, the setpoint is driven to the corresponding pre-position value. Each pre-position function has two settings: Setpoint and Adjust Rate. The setting range of each pre-position setpoint is identical to that of the corresponding control mode setpoint.

Stability Tuning

Generator stability tuning is achieved through the calculation of PID parameters. PID stands for Proportional, Integral, and Derivative. The word proportional indicates that the response of the VRM-2020 output is proportional or relative to the amount of difference observed. Integral means that the VRM-2020 output is proportional to the amount of time that a difference is observed. Integral action eliminates offset. Derivative means that the VRM-2020 output is proportional to the required rate of excitation change. Derivative action avoids excitation overshoot.

Caution

All stability tuning must be performed with no load on the system or equipment damage may occur.

Predefined Stability Settings

Twenty predefined sets of stability settings are available with the DGC-2020HD. Appropriate PID values are implemented based on the nominal generator frequency selected (see the *Device Configuration* chapter of the *Configuration* manual) and the combination of generator (T'do) and exciter (Te) time constants selected from the gain option list. (The default value for the exciter time constant is the generator time constant divided by six.)

Additional settings are available to remove the effects of noise on numerical differentiation (AVR derivative time constant Td) and set the voltage regulator gain level of the PID algorithm (Ka).

Custom Stability Settings

Stability tuning can be tailored for optimum generator transient performance. Selecting a gain option of "custom" enables entry of custom proportional (Kp), integral (Ki), and derivative (Kd) gains.

When tuning the stability gain settings, consider the following guidelines

- If the transient response has too much overshoot, decrease Kp. If the transient response is too slow, with little or no overshoot, increase Kp.
- If the time to reach steady-state is too long, increase Ki.
- If the transient response has too much ringing, increase Kd.

Parallel Compensation

With the VRM-2020, the DGC-2020HD can control the excitation level of two or more generators operating in parallel so that the generators share the reactive load. The DGC-2020HD can employ line drop compensation, droop compensation, or cross-current compensation (reactive differential) schemes for reactive load sharing. A separate load sharing function enables each machine to share the load proportionally without incurring a voltage and frequency droop.

Droop Compensation

Droop compensation serves as a method of controlling reactive current when the generator is connected in parallel with another energy source. When droop compensation is enabled, the generator voltage is adjusted in proportion to the measured generator reactive power. The reactive droop compensation setting is expressed as a percentage of the generator rated terminal voltage.

Line Drop Compensation

When enabled, line drop compensation can be used to maintain voltage at a load located at a distance from the generator. The DGC-2020HD achieves this by measuring the line current and calculating the voltage for a specific point on the line. Line drop compensation is applied to both the real and reactive portion of the generator line current. It is expressed as a percentage of the generator terminal voltage.

Equation 3-1 is used to calculate the Line Drop Value.

$$LD_{Value} = \sqrt{\left(V_{avg} - \left[LD \times I_{avg} \times \cos\left(I_{bang}\right)\right]\right)^2 + \left(LD \times I_{avg} \times \sin\left(I_{bang}\right)\right)^2}$$

Equation 3-1. Line Drop Value

LD_{Value}	=	Line drop value (per unit)
V_{avg}	=	Average voltage, metered value (per unit)
LD	=	Line Drop % / 100
I_{avg}	=	Average Current, metered value (per unit)
I_{bang}	=	Angle of phase B current (no compensation)

The LD_{Value} is the per-unit value seen down the line from the synchronous machine. Equation 3-2 is used to determine the voltage needed to adjust for line drop.

$$V_{adjust,PU} = V_{rms,PU} - LD_{Value}$$

Equation 3-2. Voltage Needed to Adjust for Line Drop

Equation 3-3 is used to obtain primary units.

$$V_{adjust} = V_{adjust,PU} \times V_{rated}$$

Equation 3-3. Obtain Primary Units

The new line drop adjusted setpoint is calculated using Equation 3-4.

$$V_{Adjusted\ Setpoint} = V_{Setpoint} + V_{adjust}$$

Equation 3-4. Line Drop Adjusted Setpoint

Cross Current Compensation

Cross-current compensation (reactive differential) mode serves as a method of connecting multiple generators in parallel to share reactive load. When reactive load is shared properly, no current is fed into the DGC-2020HD cross-current compensation input. Improper sharing of reactive load causes a differential current to be fed into the cross-current compensation CT input. When cross-current compensation is enabled, this input causes the DGC-2020HD to respond with the proper level of regulation. The response of the DGC-2020HD is controlled by the cross-current compensation gain setting which is expressed as a percentage of the generator rated CT setting.

To set up cross-current compensation, do the following for each DGC-2020HD controlling the paralleled generators:

- Connect, configure, and enable a VRM-2020 on CAN1 for each DGC-2020HD.
- Configure an auxiliary CT for cross-current on the Settings, System Parameters, Sensing Transformers screen.
- Connect the cross-current CT to the aux CT inputs on the DGC-2020HD configured for cross-current compensation. Refer to Figure 3-8 for a connection diagram.

PID Calculator

Access the PID calculator (Figure 3-13) by clicking the PID calculator button on the AVR Configuration screen (Figure 3-15). The PID calculator is available only when the primary gain option is "Custom". The PID calculator calculates the gain parameters Kp, Ki, and Kd based on the generator time constants (T'do) and exciter time constant (Te). If the exciter time constant is not known, it can be forced to the

default value which is the generator time constant divided by six. A derivative time constant (T_d) setting field enables the removal of noise effects on numerical differentiation. A voltage regulator gain (K_a) setting field sets the voltage regulator gain level of the PID algorithm. Calculated and entered parameters can be applied upon closure of the PID calculator.

Generator information appears in the PID Record List where records can be added or removed.

A group of settings can be saved with a unique name and added to a list of gain setting records available for application. Upon completion of stability tuning, undesired records can be removed from the record list.

Caution

Calculated or user-defined PID values are to be implemented only after their suitability for the application has been verified by the user. Incorrect PID numbers can result in poor system performance or equipment damage.

Primary PID Calculator

Excitation Control Data

Generator Information
|

T'do - Gen. Time Constant
2.00

Use Default Exciter Time Constant

Te - Exciter Time Constant
0.33

Gain Parameters

84.827 Kp - Proportional Gain

141.313 Ki - Integral Gain

13.510 Kd - Derivative Gain

0.01 Td - Derivative Time Constant

0.100 Ka - Voltage Regulator Gain

PID Record List

Generator Information	Kp	Ki	Kd	Td	Ka	T'do	Te
	84.827	141.313	13.510	0.01	0.100	2.00	0.33

Add Record Remove Record Apply Gain Parameters Close

Figure 3-13. PID Calculator

K_p – Proportional Gain: Read-only, calculated gain value.

K_i – Integral Gain: Read-only, calculated gain value.

K_d – Derivative Gain: Read-only, calculated gain value.

T'do – Gen. Time Constant: Select a value within the range of 1 to 15 seconds.

Te – Exciter Time Constant: Select a value within the range of 0.04 to 1.0 seconds.

Use Default Exciter Time Constant: Select or deselect.

Td – Derivative Time Constant: Adjustable from 0 to 1 in 0.01 increments.

K_a – Voltage Regulator Gain: Adjustable from 0 to 1 in 0.001 increments.

Apply Gain Parameters Button: Click button to apply gain parameters.

Close Button: Click button to close PID calculator.

Generator Information: Enter up to 30 alphanumeric characters.

Add Record: Adds a PID record.

Remove Record: Removes a PID record.

Auto Tuning

During commissioning, excitation system parameters may not be known. These unknown variables traditionally cause the commissioning process to consume large amounts of time and fuel. With the development of auto tuning, the excitation system parameters are now automatically identified and the PID gains are calculated using well-developed algorithms. Automatically tuning the PID controller greatly reduces commissioning time and cost. The auto tuning function is accessed by clicking the Auto Tune button on the AVR Configuration screen (Figure 3-15). To begin the auto tuning process the following requirements must be met: BESTCOMSP $Plus$ must be in Live Mode, the VRM-2020 must be enabled and the engine must be running.

The auto tuning window (Figure 3-14) provides options for choosing the PID Design Mode and the Power Input Mode. When the desired settings are selected, the Start Auto Tune button is clicked to start the process. After the process is complete, click the Apply Gain Parameters button to save the data. The File menu contains options for importing, exporting, and printing a graph (.gph) file.

Caution

PID values calculated by the Auto Tuning function are to be implemented only after their suitability for the application has been verified by the user. Incorrect PID numbers can result in poor system performance or equipment damage.

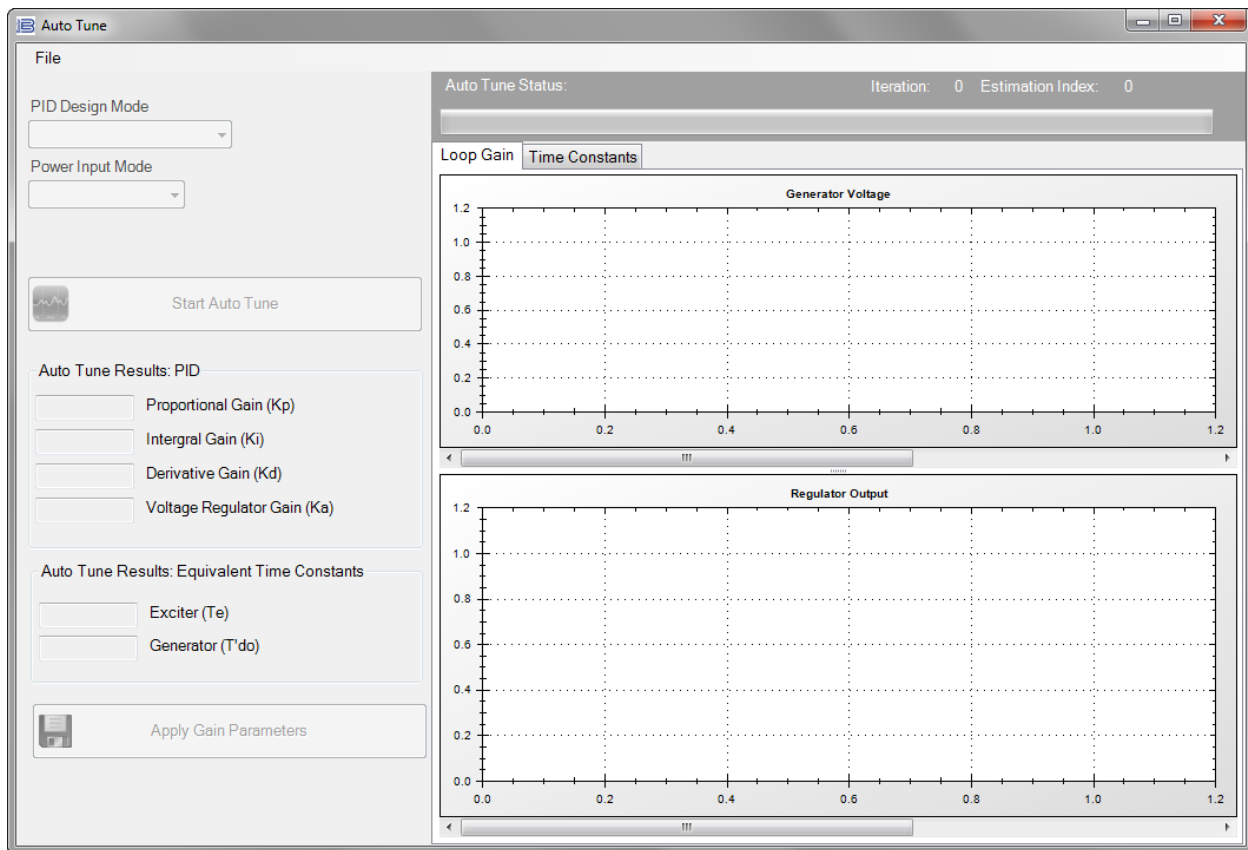

Figure 3-14. Auto Tuning Window

PID Design Mode: Set to either Pole Zero Cancellation or Pole Placement.

Power Input Mode: Set to either PMG External or Shunt.

Start Auto Tune Button: Begins the auto tuning process.

Save PID Gains Button: Saves the calculated PID gains.

Operational Settings

The BESTCOMSP $Plus$ AVR Configuration settings screen is illustrated in Figure 3-15.

AVR Configuration

Setpoint Configure

Auto Save: Disabled

Setpoint (V): 120.0

Minimum Setpoint (%): 70.0

Maximum Setpoint (%): 120.0

Adjust Rate (%/s): 1.0

Analog Bias Source: None

Bias Max (%): 0.0

Bias Min (%): 0.0

Outer Loop Bias Gain: 0.300

Outer Loop Bias Limit (%): 30.0

Analog Bias Limit: Enable

Pre-position 1

Setpoint (V): 120.0

Adjust Rate (%/s): 0.0

Pre-position 2

Setpoint (V): 120.0

Adjust Rate (%/s): 0.0

Pre-position 3

Setpoint (V): 120.0

Adjust Rate (%/s): 0.0

Pre-position 4

Setpoint (V): 120.0

Adjust Rate (%/s): 0.0

Pre-position 5

Setpoint (V): 120.0

Adjust Rate (%/s): 0.0

Gains

Kp - Proportional Gain: 40.000

Ki - Integral Gain: 20.000

Kd - Derivative Gain: 5.000

Td - Derivative Time Constant: 0.01

Ka - Voltage Regulator Gain: 0.100

PID Pre-Settings

Gain Option: Custom

PID Calculator

Auto Tuning

Auto Tune

Droop

Droop: Disabled

Droop Percent (%): 5.0

Line Drop Compensation

Line Drop Compensation: Disabled

Line Drop Percent (%): 5.0

Cross Current Compensation

Cross Current Compensation: Disabled

Cross Current Percent (%): 0.00

Cross Current CT: B

Figure 3-15. Settings Explorer, VRM Settings, AVR Configuration

FCR Mode Configuration

BESTCOMSPi+ Navigation Path: Settings Explorer, VRM Settings, FCR Configuration

Front Panel Navigation Path: Settings Explorer > VRM Control Settings > FCR

Setpoints

When operating in FCR (Field Current Regulation) mode, the DGC-2020HD regulates the level of current it supplies to the field based on the FCR setpoint. The setting range of the FCR setpoint depends on the field rated data and other associated settings. FCR setpoint adjustment is made through:

- Application of contacts at DGC-2020HD contact inputs configured for raising and lowering the active setpoint;
- Application of an analog control signal at DGC-2020HD an analog input configured for biasing the active setpoint;
- The BESTCOMSPi+ VRM Control Panel screen (available in the BESTCOMSPi+ Metering Explorer); or
- A raise or lower command transmitted through the DGC-2020HD Modbus port

The range of adjustment is defined by Minimum and Maximum settings that are expressed as a percentage of the rated field current. The Adjust Rate is the rate, in percent of rated field current per second, which the generator setpoint increases or decreases in response to raise/lower requests.

Pre-Positions

Each regulation mode has five pre-position setpoints which allow the VRM-2020 to be utilized for multiple system and application needs. Each pre-position setpoint can be assigned to a programmable contact

input on the DGC-2020HD. When the appropriate contact input is closed, the setpoint is driven to the corresponding pre-position value. Each pre-position function has two settings: Setpoint and Adjust Rate. The setting range of each pre-position setpoint is identical to that of the corresponding control mode setpoint.

Stability Tuning

The DGC-2020HD bases the VRM-2020 field current output upon the following settings.

The proportional gain (K_p) is multiplied by the error between the field current setpoint and the actual field current value. Decreasing K_p reduces overshoot in the transient response. Increasing K_p speeds the transient response.

The integral gain (K_i) is multiplied by the integral of the error between the current setpoint and the actual field current value. Increasing K_i reduces the time to reach a steady state.

The derivative gain (K_d) is multiplied by the derivative of the error between the current setpoint and the actual field current value. Increasing K_d reduces ringing in the transient response.

Additional FCR stability settings remove the noise effect on numerical differentiation (derivative time constant T_d) and set the voltage regulator gain level of the PID algorithm (K_a) with recommended gain calculation.

Operational Settings

The BESTCOMSPlus FCR Configuration settings screen is illustrated in Figure 3-16.

FCR Configuration

Setpoint Configure

Auto Save: Disabled

Setpoint (A): 1.00

Minimum Setpoint (%): 0.0

Maximum Setpoint (%): 120.0

Adjust Rate (%/s): 1.0

Analog Bias Source: None

Bias Max (%): 0.0

Bias Min (%): 0.0

Analog Bias Limit: Disable Enable

Pre-positions

Pre-position 1
Setpoint (A): 1.00
Adjust Rate (%/s): 0.0

Pre-position 2
Setpoint (A): 1.00
Adjust Rate (%/s): 0.0

Pre-position 3
Setpoint (A): 1.00
Adjust Rate (%/s): 0.0

Pre-position 4
Setpoint (A): 1.00
Adjust Rate (%/s): 0.0

Pre-position 5
Setpoint (A): 1.00
Adjust Rate (%/s): 0.0

Gains

Kp - Proportional Gain: 10.000

Ki - Integral Gain: 40.000

Kd - Derivative Gain: 0.000

Td - Derivative Time Constant: 0.00

Ka - Voltage Regulator Gain: 0.100

Figure 3-16. Settings Explorer, VRM Settings, FCR Configuration

Overexcitation Limiter

BESTCOMSPi_{us} Navigation Path: Settings Explorer/VRM Settings/Limiters/OEL

Front Panel Navigation Path: Settings Explorer > VRM Control Settings > Limiters > OEL

Operating in the overexcited region of a generator's capability curve can cause excessive field current and field winding heating. The overexcitation limiter (OEL) monitors the level of field current supplied by the VRM-2020 and limits it to prevent field overheating.

The OEL can be enabled in all regulation modes. OEL behavior in manual mode can be configured to limit excitation or issue an alarm. This behavior is configured in BESTlogicPi_{us}. Two styles of overexcitation limiting are available: Summing Point or Takeover.

OEL configuration settings are illustrated in Figure 3-17.

Figure 3-17. Settings Explorer, VRM Settings, Limiters, OEL, OEL Configure

Summing Point OEL

Summing point overexcitation limiting compensates for field overcurrent conditions while the machine is offline or online. Offline and online OEL behavior is dictated by two separate groups of settings.

Summing Point OEL settings are illustrated in Figure 3-19.

OEL Gain

The integral gain (K_i) adjusts the rate at which the VRM-2020 responds during an overexcitation condition. The loop gain (K_g) adjusts the coarse loop-gain level of the PI algorithm for the overexcitation limiter function.

Offline Operation

For offline operation, there are two levels of summing-point overexcitation limiting: High and Low. Figure 3-18 illustrates the relationship of the high-level and low-level OEL thresholds.

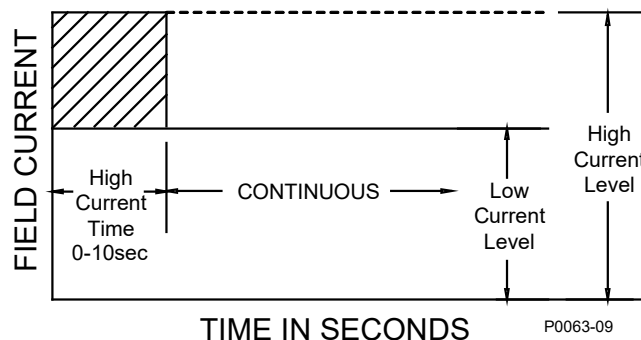

Figure 3-18. Summing Point, Offline, Overexcitation Limiting

The offline, high-level OEL threshold is determined by the High Level and High Time settings. When the excitation level exceeds the high level setting, the VRM-2020 limits the excitation to the value of the High Level setting. If this level of excitation persists for the duration of the High Time setting, the DGC-2020HD acts to limit the excitation to the value of the Low Level setting.

The offline, low-level OEL threshold is determined by the Low Level setting. When the excitation level is below the Low Level setting, no action is taken by the DGC-2020HD. The generator is permitted to operate indefinitely with this level of excitation.

Online Operation

The online, low-level OEL threshold is determined by the low-level setting. When the excitation level is below the low-level setting, no action is taken by the DGC-2020HD. The generator is permitted to operate indefinitely with this level of excitation.

The online, medium-level OEL threshold is determined by a medium level and medium time setting. When the excitation level is between the low and medium level settings, the DGC-2020HD limits the excitation to the value of the medium-level setting. If this level of excitation persists for the duration of the medium time setting, the DGC-2020HD limits the excitation to the value of the low-level setting.

The online, high-level OEL threshold is determined by a high level and high time setting. When the excitation level is between the medium and high level settings, the DGC-2020HD limits the excitation to the value of the high-level setting. If this level of excitation persists for the duration of the high time setting, the DGC-2020HD limits the excitation to the value of the medium-level setting.

To switch OEL into online mode, apply a true input to the OEL Online logic element.

OEL Voltage Dependency

The OEL Voltage Dependency function is used to enable the OEL High-Level setting when a fault is present. The OEL High-Level setting is enabled when the dv/dt level is less than the setting value. Otherwise, the Medium-Level and Low-Level settings are enabled only.

Figure 3-19. Settings Explorer, VRM Settings, Limiters, OEL, OEL Summing Point

Takeover OEL

Takeover OEL limits the field current level in relation to an inverse time characteristic similar to that shown in Figure 3-20. Separate curves may be selected for online and offline operation. If the system enters an overexcitation condition, the field current is limited and forced to follow the selected curve. The inverse time characteristic is defined by Equation 3-5.

$$t_{pickup} = \frac{A \times TD}{B + \sqrt{C + D \times MOP}}$$

Equation 3-5. Inverse Pickup Time Characteristic

Where:

t_{pickup} = time to pick up in seconds

A = -95.908

B = -17.165

C = 490.864

D = -191.816

TD = time dial setting <0.1, 20>

MOP = multiple of pickup <1.03, 205>

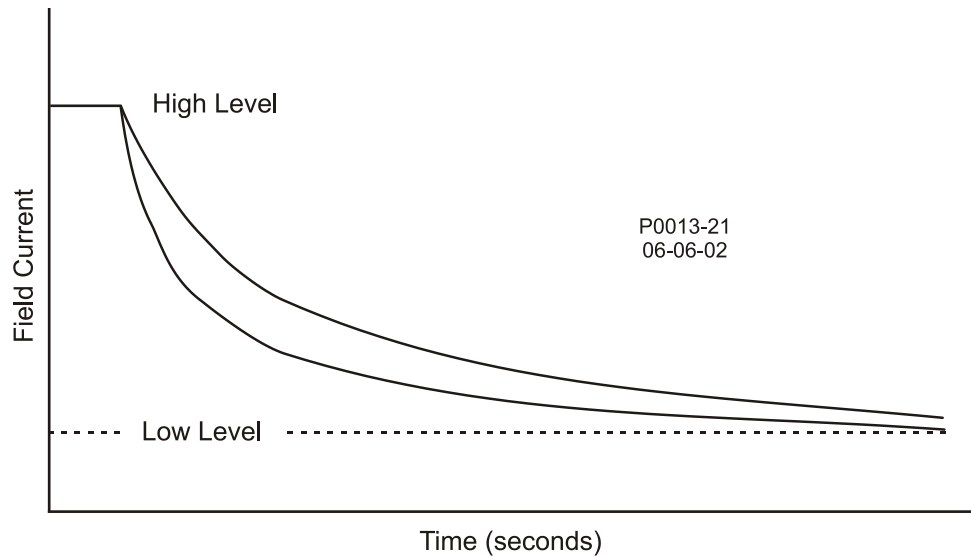

Figure 3-20. Inverse Time Characteristic for Takeover OEL

OEL Takeover Configuration

Several settings are provided for tuning takeover OEL: integral gain, loop gain, lfd filter constant, activation delay, and hysteresis. The integral gain (Ki) adjusts the rate at which the VRM-2020 responds during an overexcitation condition. The loop gain (Kg) adjusts the coarse loop-gain level of the PI algorithm for the overexcitation limiter function. An lfd Filter Constant setting adjusts the time constant for a low pass filter which is applied to the OEL error signal (lfd). An activation delay setting is provided to prevent takeover OEL from activating due to transient spikes. An overexcitation condition occurs after takeover OEL remains picked up for the duration of the activation delay. A hysteresis setting functions as a dropout by preventing rapid switching of the takeover OEL pickup.

Offline and online setting groups provide additional control for two distinct machine operating conditions. Each mode of takeover OEL operation (offline and online) has a low-level, high-level, and time dial setting.

Once the field current decreases below the dropout level (95% of pickup), the function is reset based on the selected reset method. The available reset methods are inverse, integrating, and instantaneous.

Using the inverse method, the OEL is reset based on time versus multiple of pickup (MOP). The lower the field current level, the less time is required for reset. Inverse reset uses the following curve (Equation 3-6) to calculate maximum reset time.

$$\text{Reset Time Constant} = \frac{RC \times TD}{(MOP_{\text{reset}})^2 - 1}$$

Equation 3-6. Inverse Reset Time Characteristic

Where:

Reset Time Constant	= maximum time to reset in seconds
RC	= reset coefficient setting
TD	= time dial setting
MOP _{reset}	= multiple of pickup

For the integrating reset method, the reset time is equal to the pickup time. In other words, the amount of time spent above the low level threshold is the amount of time required to reset.

Instantaneous reset has no intentional time delay.

In BESTCOMSPi_{us}, a plot of the takeover OEL setting curves is displayed. Settings enable selection of the displayed curves. The plot can display the offline or online settings curves, and the pick up or reset settings curves.

Takeover OEL settings are illustrated in Figure 3-21.

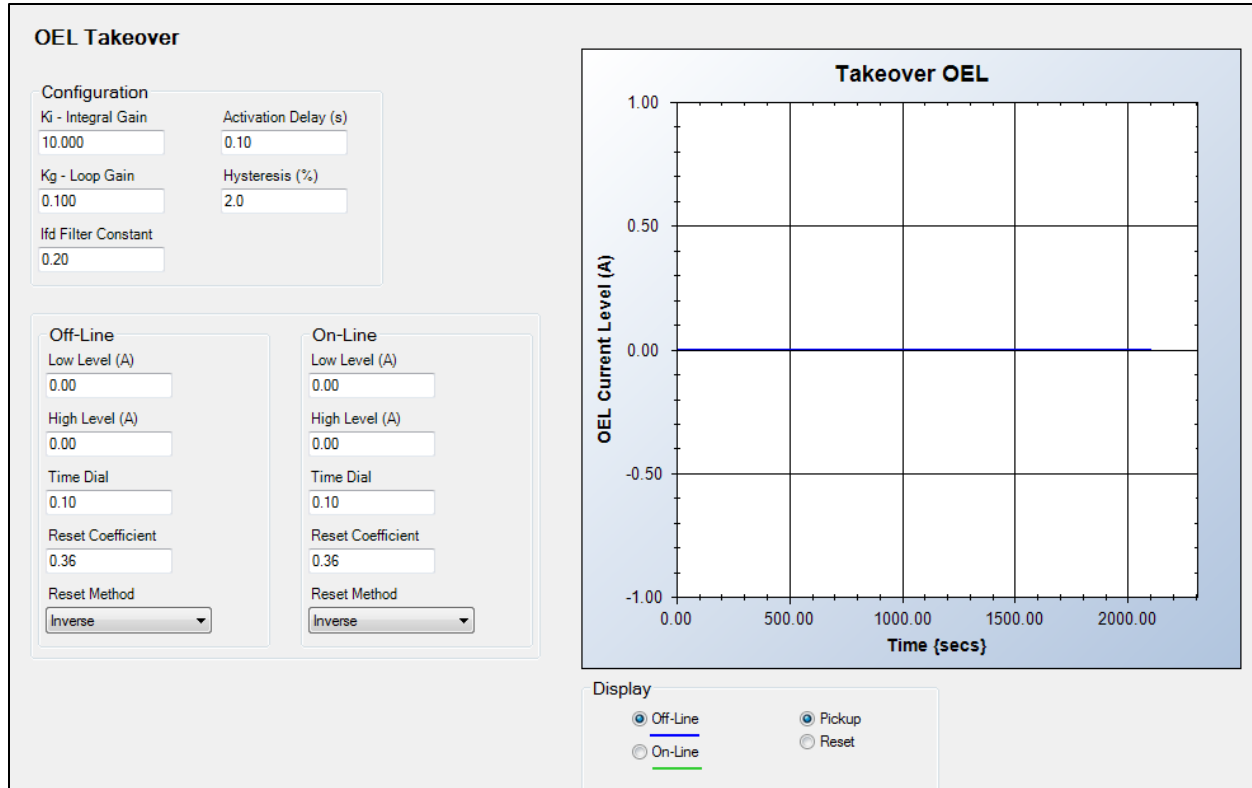

Figure 3-21. Settings Explorer, VRM Settings, Limiters, OEL, OEL Takeover

Underexcitation Limiter

BESTCOMSPPlus Navigation Path: Settings Explorer/VRM Settings/Limiters/UEL

Front Panel Navigation Path: Settings Explorer > VRM Control Settings > Limiters > UEL

Operating a generator in an underexcited condition can cause the stator end iron to overheat. Extreme underexcitation may lead to a loss of synchronism. The underexcitation limiter (UEL) senses the leading var level of the generator and limits decreases in excitation to limit end-iron heating. When enabled, the UEL operates in all regulation modes. UEL behavior in manual mode can be configured to limit excitation or issue an alarm. This behavior is configured in BESTlogicPlus.

Underexcitation limiting is implemented through an internally-generated UEL curve or a user-defined UEL curve. The internally-generated curve is based on the desired reactive power limit at zero real power with respect to the generator voltage and current rating. The absorbed reactive power axis of the curve on the UEL Custom Curve screen can be tailored for your application.

A user-defined curve can have a maximum of five points. This curve allows the user to match a specific generator characteristic by specifying the coordinates of the intended leading reactive power (kvar) limit at the appropriate real power (kW) level. The levels entered for the user-defined curve are defined for operation at the rated generator voltage.

Settings are provided for tuning the underexcitation limiter: real power filter time constant, integral gain, and loop gain. The real power filter time constant adjusts the stability of the UEL operating point by reducing noise. This filter is only applied when the customized curve is selected. The integral gain (Ki) adjusts the rate at which the VRM-2020 responds during an underexcitation condition. The loop gain (Kg) adjusts the coarse loop-gain level of the PI algorithm for the underexcitation limiter function.

An underexcitation condition occurs after UEL remains picked up for the duration of the activation delay. When an underexcitation condition occurs, selected action is performed depending on the Alarm Configuration setting. Alarm configurations are described in the *Reporting and Alarms* chapter in the *Operation* manual.

UEL settings are illustrated in Figure 3-22 and Figure 3-23.

UEL Configure

Configuration
 UEL Configured
 Disabled

Real Power Filter Time Constant (s)
 5.0

Alarm Configuration
 Status Only

Activation Delay (s)
 0

UEL Gain
 Ki - Integral Gain
 10.000

Kg - Loop Gain
 0.100

Figure 3-22. Settings Explorer, VRM Settings, Limiters, UEL, UEL Configure

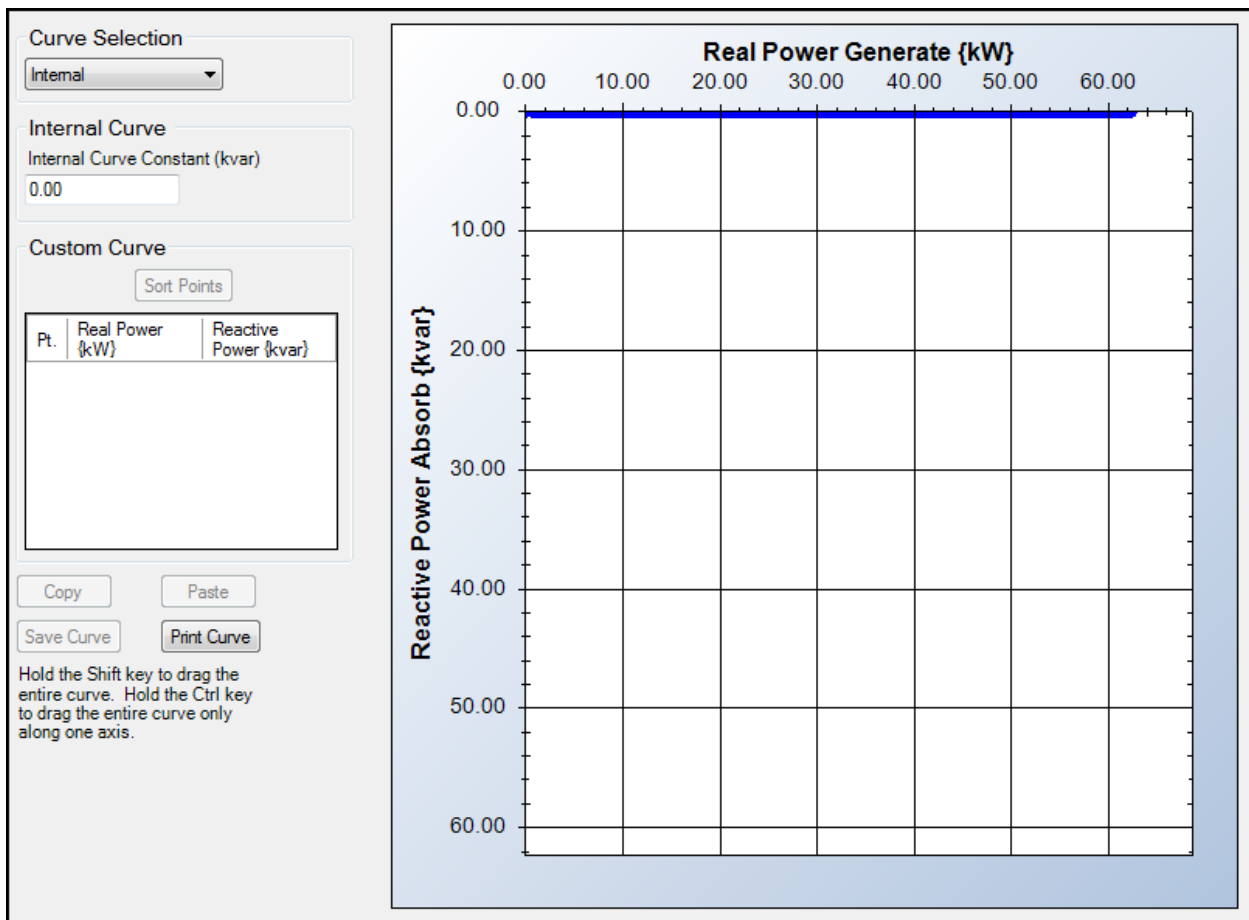

Figure 3-23. Settings Explorer, VRM Settings, Limiters, UEL, UEL Custom Curve

Curve Selection: Select Internal or Customized.

Internal Curve: Enter number to adjust range of y axis.

Custom Curve: Set five curve data points as needed.

Underfrequency

BESTCOMSPi+ Navigation Path: Settings Explorer/VRM Settings/Limiters/Underfrequency

Front Panel Navigation Path: Settings Explorer > VRM Control Settings > Limiters > Underfrequency

The underfrequency limiter is selectable for underfrequency limiting or volts per hertz limiting. These limiters protect the generator from damage due to excessive magnetic flux resulting from low frequency and/or overvoltage.

If the generator frequency decreases below either of the two corner frequencies for the configured underfrequency slopes (Figure 3-24), the DGC-2020HD adjusts the voltage setpoint so that the generator voltage follows the underfrequency slopes. The adjustment range of the corner frequency and slope settings enables the DGC-2020HD to precisely match the operating characteristics of the prime mover and the loads being applied to the generator.

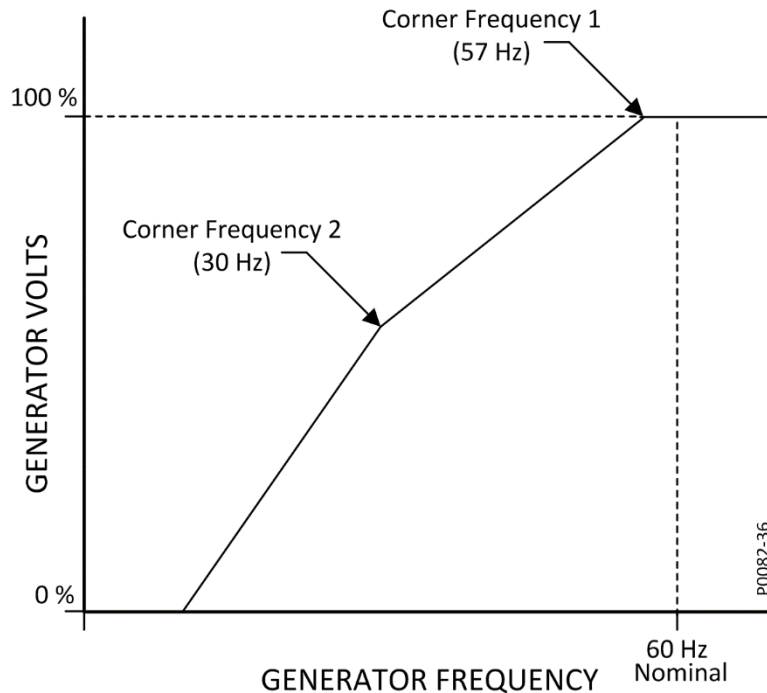

Figure 3-24. Typical Underfrequency Compensation Curve

Volts per Hertz

The volts per hertz limiter prevents the regulation setpoint from exceeding the volts per hertz ratio defined by the Underfrequency Slope setting. A typical volts per hertz limiter curve is illustrated in Figure 3-25.

Beside the Underfrequency Slope setting, volts per hertz limiter operation is determined by the High Limiter setting, Low Limiter setting, and Time Limiter setting. The High Limiter setting establishes the maximum threshold for volts per hertz limiting, the Low Limiter setting establishes the minimum threshold for volts per hertz limiting, and the Time Limiter setting establishes the time delay for limiting.

Underfrequency and volts per hertz limiter settings are illustrated in Figure 3-26.

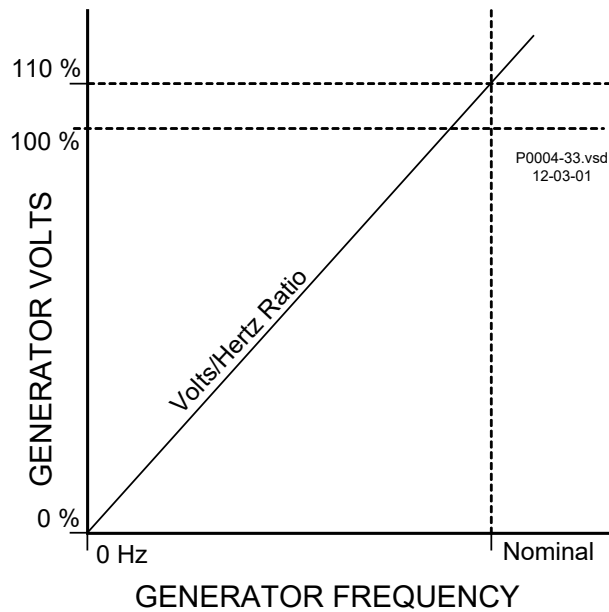

Figure 3-25. Typical 1.1 PU Volts per Hertz Limiter Curve

Underfrequency Volts/Hz Disable

When true, the UNDERFREQUENCY_VHZ_DISABLE logic block disables the Volts/Hz limiter. Refer to the *BESTLogicPlus* chapter in the *Configuration* manual for more information.

Underfrequency		
Configuration		
Mode	Underfrequency	
Minimum Voltage (V)	20	
Alarm Configuration	Status Only	
Activation Delay (s)	0	
Underfrequency Limiter		
Corner Frequency (Hz)	57.0	Corner Frequency 2 (Hz)
		10.0
Slope	1.00	Slope 2
		1.00
Volts/Hz Limiter		
V/Hz High Limiter	1.00	
V/Hz Low Limiter	1.00	
V/Hz Time Limiter (s)	10.0	

Figure 3-26. Settings Explorer, VRM Settings, Limiters, Underfrequency

Auto Tracking

BESTCOMSPlus Navigation Path: Settings Explorer, VRM Settings, Auto Tracking

Front Panel Navigation Path: Settings Explorer > VRM Control Settings > Auto Tracking

Two parameters control the behavior of internal tracking. The Delay setting determines the time delay between a large system disturbance and the start of setpoint tracking. The Adjust Rate setting configures the rate at which the inactive mode setpoints ramp towards the active mode operating point.

The BESTCOMSPlus Auto Tracking settings screen is illustrated in Figure 3-27.

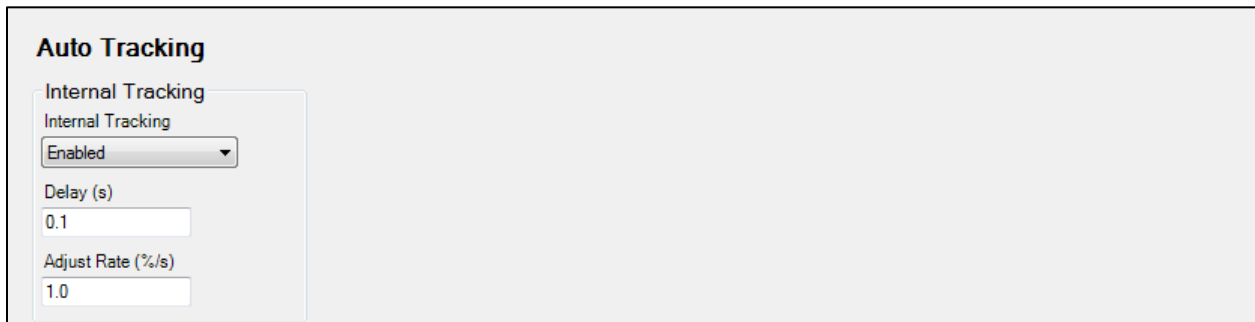

Figure 3-27. Settings Explorer, VRM Settings, Auto Tracking

Firmware Updates

Refer to the *Device Information* chapter in the *Configuration* manual for information on upgrading firmware in the VRM-2020.

Repair

VRM-2020s are manufactured using state-of-the-art surface-mount technology. These components are encased in potting material. As such, Basler Electric recommends that no repair procedures be attempted by anyone other than Basler Electric personnel.

Before returning the VRM-2020 for repair, contact Basler Electric for a return authorization number.

Maintenance

Preventive maintenance consists of periodically checking that the connections between the VRM-2020 and the system are clean and tight.

Troubleshooting

The following troubleshooting procedures assume the excitation system components are properly matched, fully operational, and correctly connected. If you do not obtain the results that you expect from the DGC-2020HD, first check the programmable settings for the appropriate function.

Communications

No Communication

If the VRM Comms Fail pre-alarm is active, check the connections at the communication ports.

General Operation

Generator Voltage Does Not Build

Step 1: Verify that all wiring is properly connected. Refer to the *Typical Applications* chapter in the *Installation* manual.

If wiring is improperly connected or loose, reconnect wiring properly.

If wiring connections are correct, proceed to Step 2.

Step 2: Verify that the generator is spinning at rated speed.

If the generator is not up to rated speed, increase generator speed to the rated value.

If the generator is spinning at rated speed, proceed to Step 3.

- Step 3: Check for correct input power to the VRM-2020. Refer to the *Specifications* section in this chapter for input power requirements.
If voltage is not present, refer to the generator manual for repair procedures.
If voltage is present, proceed to Step 4.
- Step 4: Verify that no fuses are open.
Replace any open fuses.
If no fuses are open, proceed to Step 5.
- Step 5: Verify that the generator is not shut down through *BESTlogicPlus*.
- Step 6: Verify that the overexcitation limiter is not active.
If the overexcitation limiter is active, check the generator and/or load conditions. Interrupt input power or shut down the generator for a minimum of one minute.
If the overexcitation limiter is not active, proceed to Step 7.
- Step 7: Verify that the VRM-2020 soft start settings are correct. Too long of a soft start setting may give the appearance of no buildup.
If the soft start settings are incorrect, adjust the settings.
If the soft start settings have no effect, proceed to Step 8.
- Step 8: Replace the DGC-2020HD / VRM-2020.
If replacing the DGC-2020HD / VRM-2020 does not correct the malfunction, then the generator is defective. Consult with the generator manufacturer.

Low Generator Output Voltage

- Step 1: Verify that the voltage adjustment is not set too low.
If the voltage adjustment is too low, adjust it to the correct setpoint.
If the voltage adjustment is correct, proceed to Step 2.
- Step 2: Verify that the Underfrequency Knee setpoint is not greater than the generator frequency.
If the Underfrequency setpoint is too high, adjust the setpoint below the rated generator frequency.
If the Underfrequency setpoint is correct, proceed to Step 3.
- Step 3: Verify that the generator is spinning at rated speed.
If the generator is not up to rated speed, increase the generator speed to the rated level.
If the generator is spinning at rated speed, proceed to Step 4.
- Step 4: Check for correct input power to the VRM-2020. Refer to the *Specifications* section in this chapter for input power requirements.
If the VRM-2020 input voltage is low, refer to the PMG manual for PMG repair.
If the voltage is at the required level, proceed to Step 5.
- Step 5: Verify that the sensing potential transformer (if used) has the correct turns ratio and is operating correctly.
If the turns ratio of the sensing potential transformer is incorrect, replace the sensing potential transformer.
If the sensing potential transformer is operating correctly, proceed to Step 6.
- Step 6: Verify that the overexcitation limiter is not active.

If the overexcitation limiter is active, check the generator and/or load conditions. Also check the Field Current Limit setpoint for the correct level. Interrupt input power or shut down the generator for a minimum of one minute.

If the overexcitation limiter is not active, proceed to Step 7.

Step 7. Low generator output voltage may occur when operating in droop mode with an inductive load. If the low voltage condition is not caused by the droop function, proceed to Step 8.

Step 8. Verify that the Voltage setpoint is not being modified by application of voltage or current to an analog input.

If the low voltage condition is not caused by an analog input, proceed to Step 9.

Step 9. Replace the DGC-2020HD / VRM-2020.

High Generator Output Voltage

Step 1. Verify that the voltage adjustment is not set too high.

If the voltage adjustment is too high, adjust it to the correct setpoint.

If the voltage adjustment is correct, proceed to Step 2.

Step 2. Verify that the sensing potential transformer (if used) has the correct turns ratio.

If the turns ratio of the sensing potential transformer is incorrect, replace the sensing potential transformer with the correct one.

If the sensing potential transformer is correct, proceed to Step 3.

Step 3. High generator output voltage may occur when operating in droop mode with a capacitive load.

If the high voltage condition is not caused by the droop function, proceed to Step 4.

Step 4. High generator output voltage may occur when operating in line-drop compensation mode with a capacitive load.

If the high voltage condition is not caused by the line-drop compensation function, proceed to Step 5.

Step 5. Verify that the Voltage setpoint is not being modified by application of voltage or current to an analog input.

If the high voltage condition is not caused by voltage applied to an analog input, proceed to Step 6.

Step 6. Replace the DGC-2020HD / VRM-2020.

Poor Voltage Regulation

Step 1. Verify that the VRM-2020 is properly grounded.

If the VRM-2020 is not properly grounded, connect a dedicated ground wire to the terminal labeled CGND on the VRM-2020.

If the VRM-2020 is properly grounded, proceed to Step 2.

Step 2. Check for grounded field leads.

If the field leads are grounded, isolate them from ground.

If the field leads are not grounded, proceed to Step 3.

Step 3. Check for grounded PMG leads.

If the PMG leads are grounded, isolate them from ground.

If the PMG leads are not grounded, proceed to Step 4.

- Step 4. Verify that the generator frequency is not dropping below the Underfrequency setpoint when load is applied to the generator.
If the generator frequency is dropping below the Underfrequency setpoint, reduce the setpoint if possible. Also check the prime mover and generator for proper sizing in relation to the applied load.
If poor regulation is not related to underfrequency operation, proceed to Step 5.
- Step 5. Verify that regulation is not being affected by normal droop operation.
If droop operation is not affecting regulation, proceed to Step 6.
- Step 6. Replace the DGC-2020HD / VRM-2020.

Generator Output Unstable (Hunting)

- Step 1. Verify that the governor for the prime mover is operating properly.
If the governor is not operating properly, troubleshoot using the manufacturer's suggested procedures.
If the governor is operating properly, proceed to Step 2.
- Step 2. Verify that the sensing and input power leads are connected securely.
If the sensing or input power leads are not connected securely, tighten the connections.
If the sensing or input power lead connections are secure, proceed to Step 3.
- Step 3. Verify that the DGC-2020HD AVR gains are set properly.
If the gain settings are incorrect, reset the gains.

Overexcitation Shutdown Indicator is Annunciating

- Step 1. Check for generator overloading.
If the generator is operating with a larger than rated load, shed load.
If the generator is operating with a rated or less than rated load, proceed to Step 2.
- Step 2. Verify that the generator exciter field voltage requirements are compatible with the DGC-2020HD / VRM-2020.
If the exciter field voltage requirements are not compatible with the DGC-2020HD / VRM-2020, contact Basler Electric Customer Service for recommendations.
If the exciter field voltage requirements are compatible with the DGC-2020HD / VRM-2020, proceed to Step 3.
- Step 3. Replace the DGC-2020HD / VRM-2020.
If replacing the DGC-2020HD / VRM-2020 does not correct the malfunction, proceed to Step 4.
- Step 4. Refer to the generator manual. Generator is defective.

Loss of Generator Sensing Indicator is Annunciating

- Step 1. Verify that the voltage sensing leads are properly connected.
If the sensing leads are not properly connected, correct the connections.
If the sensing lead connections are correct, proceed to Step 2.
- Step 2. Verify that the sensing potential transformer (if used) has the correct turns ratio and is functioning properly.
If the sensing potential transformer has the wrong turns ratio or is malfunctioning, replace it.
If the sensing potential transformer is correct and functioning properly, proceed to Step 3.

Step 3. Verify that the generator output voltage is present on all phases.
If the generator is missing a phase, refer to the generator manual. Generator is defective.
If generator output voltage is balanced on all phases, proceed to Step 4.

Step 4. Replace the DGC-2020HD / VRM-2020.

Overexcitation Limiting Indicator is Annunciating

Step 1. Check for generator overloading.
If the generator is operating with a larger than rated load, shed load.
If the generator is operating with a rated or less than rated load, proceed to Step 2.

Step 2. Verify that the VRM-2020 output (field) current limit is not set too low.
If the Output Current Limit setpoint is too low, adjust for the proper setting.
If the output current limit is set properly, proceed to Step 3.

Step 3. Verify that the generator exciter field current requirements are compatible with the DGC-2020HD / VRM-2020.
If the generator exciter field current requirements are not compatible with the DGC-2020HD / VRM-2020, contact Basler Electric Customer Service for recommendations.
If the generator exciter field current requirements are compatible with the DGC-2020HD / VRM-2020, proceed to Step 4.

Step 4. Replace the DGC-2020HD / VRM-2020.
If replacing the DGC-2020HD / VRM-2020 does not correct the malfunction, proceed to Step 5.

Step 5. Refer to the generator manual. Generator is defective.

Underexcitation Limiting Indicator is Annunciating

Step 1. Verify that the DGC-2020HD Generator Voltage setpoint is not being driven to a lower level.
The setpoint can be affected by Raise and Lower commands, analog biases, and five pre-positions. The regulation point may also be modified by the Droop function or the Underfrequency function under certain conditions.

Step 2. Verify that the DGC-2020HD output (field) current limit is not set too low.
Adjust the field current limit as needed.

Step 3. Use the connection diagrams of the *Typical Applications* chapter in the *Installation* manual to verify that the sensing voltage and current connections to the DGC-2020HD provide the proper phasing.
Correct the sensing voltage and current connections as needed.

Step 4. Verify that the generator exciter field current requirements are compatible with the DGC-2020HD / VRM-2020.
If the generator exciter field current requirements are not compatible with the DGC-2020HD / VRM-2020, contact Basler Electric Technical Sales Support for recommendations.
If the generator exciter field current requirements are compatible with the DGC-2020HD / VRM-2020, proceed to Step 5.

Step 5. Replace the DGC-2020HD / VRM-2020.
If replacing the DGC-2020HD / VRM-2020 does not correct the malfunction, proceed to Step 6.

Step 6. Refer to the generator manual or contact the generator manufacturer.

Underfrequency Active Indicator is Annunciating

- Step 1. Verify that the generator is operating at rated speed.
If the generator is not operating at rated speed, adjust the generator speed.
If the generator is operating at the rated speed, proceed to Step 2.
- Step 2. Verify that the Underfrequency setpoint is correct.
If the Underfrequency setpoint is incorrect, adjust it to the correct value.

No Droop

- Step 1. Verify that the DGC-2020HD PARTOMAINS, Paralleled input (if present) is false or the Var/PF function is disabled via BESTCOMSPlus. Var/PF operation causes the influence of droop to be insignificant. If var/PF operation is disabled, proceed to Step 2.
- Step 2. Verify that the DGC-2020HD droop setting is not adjusted to 0% droop.
If the droop setting is adjusted to 0% droop, increase the setpoint above 0%.
If the droop setting is adjusted to above 0%, proceed to Step 3.
- Step 3. Check for an open in the circuit connected to the DGC-2020HD current sensing transformers.
If there is an open circuit, repair as necessary.
If there is no open circuit, proceed to Step 4.
- Step 4. Verify that all connections are correct. Refer to the *Typical Applications* chapter in the *Installation* manual.
If connections are incorrect, correct the problem.
If connections are correct, proceed to Step 5.
- Step 5. Verify that droop is not disabled through BESTlogicPlus.
- Step 6. Verify that the load applied to the generator for droop testing is not purely resistive.
If only a resistive load is being applied to the generator, apply an inductive load and retest.
If the load being to the generator is inductive, proceed to Step 7.
- Step 7. Verify that your DGC-2020HD is compatible with the current sensing transformer (1 A or 5 A secondary) being used. For example, a current sensing transformer with a 1 ampere output rating would produce very little droop if the DGC-2020HD has a 5 ampere current transformer input. To check the current transformer input of your DGC-2020HD, refer to the style chart in the *Device Information* chapter of the *Configuration* manual.
If the current transformer input is incorrect, replace the current sensing transformer or the DGC-2020HD for compatibility.
If the current transformer input is correct, proceed to Step 8.
- Step 8. If the above steps fail to correct the malfunction, replace the DGC-2020HD / VRM-2020 unit.

Storage

This device contains a long-life aluminum electrolytic capacitor. For devices that are not in service (spares in storage), the life of this capacitor can be maximized by energizing the device for 30 minutes once per year.



Highland, Illinois USA
Tel: +1 618.654.2341
Fax: +1 618.654.2351
email: info@basler.com

Suzhou, P.R. China
Tel: +86 512.8227.2888
Fax: +86 512.8227.2887
email: chinainfo@basler.com