

INSTRUCTION MANUAL

FOR

**MODIFIED BE1-79A
RECLOSING RELAY**

Part Numbers

9310200109

9310200111



Publication: 9310200999

Revision: F1 01/19

en	 WARNING: This product can expose you to chemicals including Nickel, which is known to the State of California to cause cancer. For more information go to www.P65Warnings.ca.gov .
fr	 AVERTISSEMENT : Ce produit peut vous exposer à des produits chimiques, y compris le Nickel, qui connaît l'état de Californie pour causer le cancer. Pour plus d'informations, allez à www.P65Warnings.ca.gov .
es	 ADVERTENCIA: Este producto puede exponerlo a productos químicos incluyendo el níquel, que se conoce en el estado de California como causantes de cáncer. Para más información, visite www.P65Warnings.ca.gov .
zh	 警告: 本产品可以让您接触到包括镍在内的化学物质, 而这是加利福尼亚州已知的致癌物。有关更多信息, 请转到 www.P65Warnings.ca.gov 。
ru	 Предупреждение: Этот продукт могут подвергнуть вас химических веществ, включая никель, который известен в штате Калифорния вызывают рак. Для получения дополнительной информации перейдите на www.P65Warnings.ca.gov .
de	 Warnung: Dieses Produkt kann setzen Sie auf Chemikalien wie z.B. Nickel, die in Kalifornien bekannt ist, um Krebs zu verursachen. Weitere Informationen finden Sie unter www.P65Warnings.ca.gov .
pt	 Aviso: Este produto pode expô-lo a produtos químicos, incluindo o níquel, que é conhecido no estado da Califórnia por causar câncer. Para mais informações acesse www.P65Warnings.ca.gov .
it	 Avvertenza: Questo prodotto può esporre a prodotti chimici quali il nichel, che è noto per lo stato della California come causa di tumori. Per ulteriori informazioni visitare www.P65Warnings.ca.gov .
bg	 Предупреждение: Този продукт може да ви изложи на химикали, включително никел, което е известно за състоянието на Калифорния да причини рак. За повече информация отидете на www.P65Warnings.ca.gov .

Ref. 94380002

INTRODUCTION

This instruction manual provides information about the operation and installation of the BE1-79A Reclosing Relay. To accomplish this, the following information is provided:

- General Information and Specifications
- Controls and Indicators
- Functional Description
- Installation
- Maintenance

WARNING!

To avoid personal injury or equipment damage, only qualified personnel should perform the procedures in this manual.

NOTE

Be sure that the BE1-79A is hard-wired to earth ground with no smaller than 12 AWG copper wire attached to the ground terminal on the rear of the unit case. When the BE1-79A is configured in a system with other devices, it is recommended to use a separate lead to the ground bus from each unit.

First Printing: September 2002

Printed in USA

© 2018 Basler Electric, Highland Illinois 62249 USA

All Rights Reserved

March 2018

CONFIDENTIAL INFORMATION

of Basler Electric, Highland Illinois, USA. It is loaned for confidential use, subject to return on request, and with the mutual understanding that it will not be used in any manner detrimental to the interest of Basler Electric.

It is not the intention of this manual to cover all details and variations in equipment, nor does this manual provide data for every possible contingency regarding installation or operation. The availability and design of all features and options are subject to modification without notice. Should further information be required, contact Basler Electric.

**BASLER ELECTRIC
12570 STATE ROUTE 143
HIGHLAND IL 62249 USA**

<http://www.basler.com>, info@basler.com

PHONE +1 618.654.2341

FAX +1 618.654.2351

REVISION HISTORY

The following information provides a historical summary of the changes made to the BE1-79A hardware, firmware, and software. The corresponding revisions made to this instruction manual (9310200999) are also summarized. Revisions are listed in reverse chronological order.

Application Firmware Version and Date	Change
1.07, 02/08	<ul style="list-style-type: none"> Modified firmware so the relay will go to Lockout after the EXIT command is entered through the RS-232 port or access has timed out. If the breaker is closed, the relay will go to Reset after the Lockout Timer expires.
1.06, 09/01	<ul style="list-style-type: none"> Initial release.

9310200109 Hardware Version and Date	Change
G, 07/13	<ul style="list-style-type: none"> Improved manufacturing process.
F, 03/10	<ul style="list-style-type: none"> Improved manufacturing process.
E, 02/08	<ul style="list-style-type: none"> Released firmware 1.07.
D, 01/06	<ul style="list-style-type: none"> Added de-coupling capacitors across resistors R37-R41 on digital board to prevent mis-operation at high temperatures.
C, 02/05	<ul style="list-style-type: none"> Improved digital board.
B, 08/04	<ul style="list-style-type: none"> Changed packing material.
A, 01/03	<ul style="list-style-type: none"> Replaced the MOV on the power supply with a more reliable part.
—, 09/02	<ul style="list-style-type: none"> Initial release.

9310200111 Hardware Version and Date	Change
B, 07/13	<ul style="list-style-type: none"> Improved manufacturing process.
A, 03/10	<ul style="list-style-type: none"> Improved manufacturing process.
—, 10/08	<ul style="list-style-type: none"> Initial release.

Manual Revision and Date	Change
F, 03/18	<ul style="list-style-type: none"> Removed GOST-R certification from Section 1. Added Storage statement in Section 5. Minor text edits.
E, 12/11	<ul style="list-style-type: none"> In Table 1-1, stated that connection plugs are included with all relays. Added GOST-R Certification in Section 1. In Figure 3-2, removed shorting bars between terminals 9 & 10 and 15 & 16.
D, 06/11	<ul style="list-style-type: none"> Corrected Figure 6-1. Updated formatting style.
C, 03/09	<ul style="list-style-type: none"> Removed addendum and implemented modifications throughout entire manual.
B, 02/09	<ul style="list-style-type: none"> Changed references of “ACR” to “NLR” in addendum.

Manual Revision and Date	Change
A, 10/08	<ul style="list-style-type: none">• Added P/N 9310200111 to BE1-79A models covered by this manual.
—, 09/02	<ul style="list-style-type: none">• Initial release

CONTENTS

SECTION 1 • GENERAL INFORMATION	1-1
SECTION 2 • CONTROLS AND INDICATORS.....	2-1
SECTION 3 • FUNCTIONAL DESCRIPTION	3-1
SECTION 4 • COMMUNICATION COMMANDS	4-1
SECTION 5 • INSTALLATION AND CONFIGURATION	5-1
SECTION 6 • TESTING	6-1
APPENDIX A • RS CONTACT APPLICATION.....	A-1
APPENDIX B • TERMINAL COMMUNICATION.....	B-1



SECTION 1 • GENERAL INFORMATION

TABLE OF CONTENTS

SECTION 1 • GENERAL INFORMATION	1-1
Description	1-1
Features	1-2
Controls and Indicators	1-2
Communication	1-2
Primary Application	1-2
Specifications	1-2
Reclose Timers 1, 2, 3, and 4	1-2
Reset Timers 1, 2, 3, 4, and Final	1-2
Lockout Timer.....	1-3
RS Set and Reset Timers.....	1-3
Communication Port.....	1-3
Power Supply	1-3
Contact Sensing Inputs	1-3
Output Contacts	1-3
Type Tests.....	1-3
Environment	1-4
Weight	1-4
Patent	1-4
Maintenance.....	1-4
Tables	
Table 1-1. BE1-79A Versions and Features.....	1-1



SECTION 1 • GENERAL INFORMATION

Description

The BE1-79A Reclosing Relay is an economical, microprocessor-based relay that automatically recloses circuit breakers that have been tripped by protective relays or other devices in power transmission and distribution systems. The BE1-79A can be installed in an existing GE NLR-21U case with some wiring changes required. General Electric type NLR-21U reclosing relays can be directly replaced by the BE1-79A-109 or BE1-79A-111.

NOTE

Verify that the correct retrofit has been selected for the application. Table 1-1 lists the case style and special features of each version of the BE1-79A.

Table 1-1. BE1-79A Versions and Features

Catalog Number	Basler Relay Part Number	Retrofit for	Options	Cradle Style
BE1-79A-100*	9310200100	GE 12ACR-11A GE 12ACR-11B	None Plugs into existing case. Connection plugs included. No rewiring required.	S2
BE1-79A-101*	9310200101	GE 12ACR-11A GE 12ACR-11B	Power holdup circuit. Plugs into existing case. Connection plugs included. No rewiring required.	S2
BE1-79A-109	9310200109	GE 12NLR-21U 125 Vdc	None Plugs into existing NLR case. Connection plugs included. Requires some rewiring on back of case.	S2
BE1-79A-111	9310200111	GE 12NLR-21U 48 Vdc	None Plugs into existing NLR case. Connection plugs included. Requires some rewiring on back of case.	S2
BE1-79A-200*	9310200200	GE 12ACR-11A GE 12ACR-11B	Mounting case and connection plugs included.	S1
BE1-79A-201*	9310200201	GE 12ACR-11A GE 12ACR-11B	Power holdup circuit. Mounting case and connection plugs included.	S1

* Refer to *Instruction Manual for BE1-79A*, part number 9310200990.

Features

BE1-79A Multiple Shot Reclosing Relays have the following standard features:

- Rugged construction in a steel, draw-out case
- A maximum of four automatic reclosures
- A maximum of four automatic resets
- Lockout function
- Selectable instantaneous or delayed first reclosure
- Selectable internal or external instantaneous jumper
- Selectable normally closed or normally open RS output contact
- Selectable Relay Fail or Lockout and Relay Fail output contact
- Selectable contact sensing voltage range

Controls and Indicators

The front panel has indicators to verify relay power and recloser status. A Reset switch is provided to restore the relay to the reset mode by clearing a reclosing sequence or a lockout condition. The left side of the relay cradle has switches (S1, S2, and S3) to configure the relay for NLR-21U operation. The right side of the cradle has a switch (S4) to select either an internal or an external jumper for an instantaneous, first reclose. The right side of the cradle also has a switch (S5) to select either normally open or normally closed operation of the RS contact.

Communication

All relay settings are read or changed through the serial port located on the front panel. The BE1-79A uses ASCII protocol.

Primary Application

The BE1-79A automatically recloses circuit breakers that have been tripped by protective relays or other devices in power transmission and distribution systems.

Over 90% of faults occurring on overhead lines may be cleared by momentarily de-energizing the line. Once the circuit breaker has been opened to de-energize the line, the BE1-79A provides a reliable automatic reclosure. The advantages are:

- Improved service continuity—returns the line to service quickly, preserving line integrity and minimizing outage effects on critical loads.
- System stability—prevents disjointing of the system grid.
- Higher line availability—decreases likelihood of permanent loss of line.
- The relay will function like a GE NLR-21U relay.

Specifications

BE1-79A relays have the following features and capabilities.

Reclose Timers 1, 2, 3, and 4

Range 0 to 300 seconds
Increments 0.1 second
Accuracy ± 20 milliseconds $\pm 1\%$, typical
 ± 50 milliseconds $\pm 1\%$, maximum

Reset Timers 1, 2, 3, 4, and Final

Range 0 to 300 seconds
Increments 0.1 seconds
Accuracy ± 20 milliseconds $\pm 1\%$, typical
 ± 50 milliseconds $\pm 1\%$, maximum

Lockout Timer

Range 0 to 300 seconds
Increments 0.1 seconds
Accuracy ± 20 milliseconds $\pm 1\%$, typical
 ± 50 milliseconds $\pm 1\%$, maximum

RS Set and Reset Timers

Range 0 to 300 seconds
Increments 0.1 seconds
Accuracy ± 20 milliseconds $\pm 1\%$, typical
 ± 50 milliseconds $\pm 1\%$, maximum

Communication Port

Parameters 9600 baud, 8N1 half duplex
Protocol ASCII

Power Supply

9310200109

Operating Range 125 to 250 Vdc
120 to 240 Vac

9310200111

Operating Range 38 to 150 Vdc
90 to 132 Vac

Contact Sensing Inputs

Operating Range (Jumper Selectable)

48 Vdc, Nominal 38 to 275 Vdc
125 Vdc/120 Vac, Nominal 100 to 275 Vdc, or 96 to 264 Vac
250 Vdc/240 Vac, Nominal 200 to 275 Vdc, or 192 to 264 Vac
Energizing Level 80% of nominal
Current Draw 1.5 mA maximum per input

Recognition Time

Typical 15 ms for dc, ac (45 to 65 Hz)
Maximum 25 ms for dc, ac (45 to 65 Hz)

Dropout Time

Typical 15 ms for dc, ac (45 to 65 Hz)
Maximum 25 ms for dc, ac (45 to 65 Hz)

Output Contacts

Resistive Ratings

120 Vac Make, break, and carry 7 Aac continuously
250 Vdc Make and carry 30 Adc for 0.2 s, carry 7 Adc continuously,
break 0.3 Adc
500 Vdc Make and carry 15 Adc for 0.2 s, carry 7 Adc continuously,
break 0.3 Adc

Inductive Ratings

120 Vac, 125 Vdc, 250 Vdc Break 0.3 A (L/R = 0.04)

Type Tests

Electrostatic Discharge (ESD)

8 kV contact discharges and 15 kV air discharges applied in accordance with IEC 801-2 ESD.

Dielectric Strength

1,500 Vac at 50/60 Hz in accordance with IEEE C37.90

The RS-232 serial communication port is intended only for periodic use and is not subject to the requirements of IEEE C37.90.

Surge Withstand Capability - Oscillatory and Fast Transient

Qualified to IEEE C37.90.1-1989 *Standard Surge Withstand Capability (SWC) Tests for Protective Relays and Relay Systems*. The RS-232 Serial Communication Port is intended only for periodic use and is not subject to the requirements of IEEE C37.90.1.

Radio Frequency Interference (RFI)

Type tested using a 5 W, hand-held transceiver in the ranges of 144 and 440 MHz with the antenna placed within 6 inches (152 millimeters) of the relay.

Shock

In standard tests, the relay has withstood 15 G in each of three mutually perpendicular planes without structural damage or degradation of performance.

Vibration

In standard tests, the relay has withstood 2 G in each of three mutually perpendicular planes, swept over the range of 10 to 500 Hz for six sweeps, 15 minutes each sweep, without structural damage or degradation of performance.

Environment

Operating Temperature Range.. –40 to 70°C (–40 to 158°F)

Storage Temperature Range –40 to 85°C (–40 to 185°F)

Humidity..... Qualified to IEC 68-2-38, 1st Edition 1974, *Basic Environmental Test Procedures, Part 2: Test Z/AD: Composite Temperature Humidity Cyclic Test*

Weight

BE1-79A-109, -111 5 lb (2.3 kg) maximum

Patent

Number 6,239,960

Maintenance

BE1-79A relays require no preventive maintenance. However, testing should be performed according to scheduled practices. If the relay fails to function properly, contact the Technical Support Services department of Basler Electric for a return authorization number before returning the relay for service.

SECTION 2 • CONTROLS AND INDICATORS

TABLE OF CONTENTS

SECTION 2 • CONTROLS AND INDICATORS	2-1
Front Panel.....	2-1
Style Configuration Switches	2-2
Instantaneous Reclose Jumper Switch and RS Contact Switch	2-2

Figures

Figure 2-1. Front Panel Controls and Indicators	2-1
Figure 2-2. Style Configuration Switches	2-2
Figure 2-3. Instantaneous Reclose Jumper Switch and RS Contact Selection Switch.....	2-3

Tables

Table 2-1. Front Panel Control and Indicator Descriptions	2-1
---	-----



SECTION 2 • CONTROLS AND INDICATORS

Front Panel

Front panel controls and indicators are illustrated in Figure 2-1 and described in Table 2-1. The locators and descriptions of Table 2-1 correspond to the locators shown in Figure 2-1.

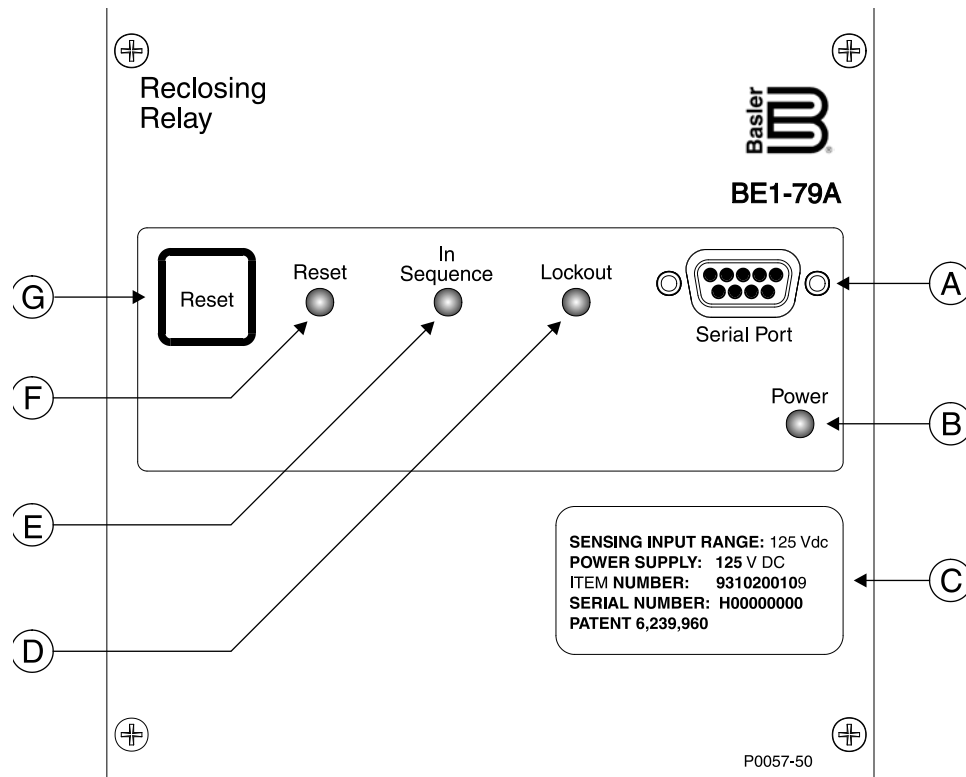

Figure 2-1. Front Panel Controls and Indicators

Table 2-1. Front Panel Control and Indicator Descriptions

Locator	Description
A	<i>RS-232 Serial Communication Port.</i> A PC or computer terminal running a terminal emulation program such as Windows® HyperTerminal can be connected to this port so that relay settings can be read or changed. Communication with the BE1-79A uses a simple ASCII command language.
B	<i>Power LED.</i> A lit Power LED indicates that operating power is applied to the relay.
C	<i>Identification Label.</i> Shows relay information such as the sensing input range, power supply type, serial number, and part number.
D	<i>Lockout LED.</i> When lit, this LED indicates that the relay is in the lockout state.
E	<i>In Sequence LED.</i> A lit In Sequence LED indicates any one of the following states: <ul style="list-style-type: none"> • Timing to reclose • Timing to reset • Timing to lockout • Attempting to reclose • Attempting to reset
F	<i>Reset LED.</i> When lit, this LED indicates that the relay is in the reset state.
G	<i>Reset Pushbutton.</i> Pressing this momentary switch clears the In Sequence or Lockout LEDs and restores the relay to the reset state.

Style Configuration Switches

Three switches on the left side of the relay cradle are used to configure the BE1-79A for NLR-21U operation. Figure 2-2 illustrates the location of the style configuration switches. The BE1-79A is delivered with switches S1, S2, and S3 placed in the “A” position. Refer to Section 5, *Installation and Configuration*, for details on how to configure the BE1-79A for NLR-21U operation.

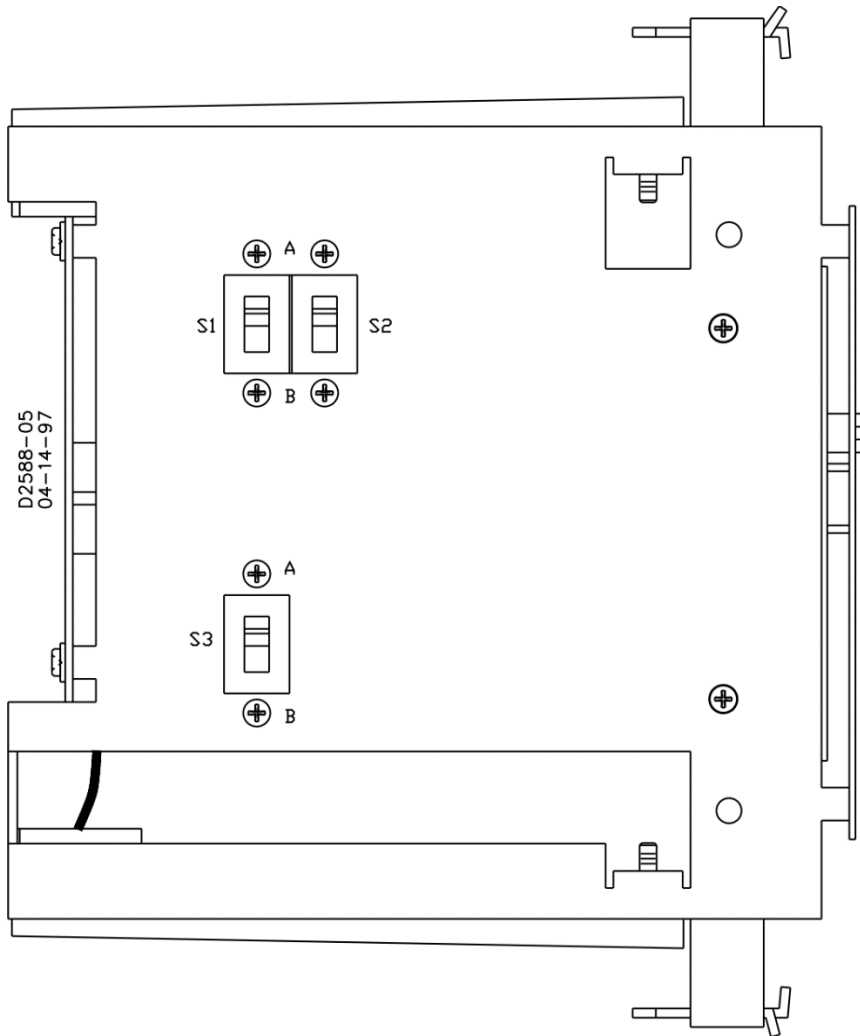

Figure 2-2. Style Configuration Switches

Instantaneous Reclose Jumper Switch and RS Contact Switch

Two switches on the right side of the relay cradle select either internal or external jumpering for an instantaneous first reclosure and for selecting normally-closed or normally-open operation of the RS contact. Switch S4 is used to select internal or external jumpering and switch S5 is used to select normally-open or normally-closed operation of the RS contact. Figure 2-3 illustrates the location of switches S4 and S5. The BE1-79A is delivered with switch S4 placed in the “EXT” position and switch S5 placed in the “NC” position.

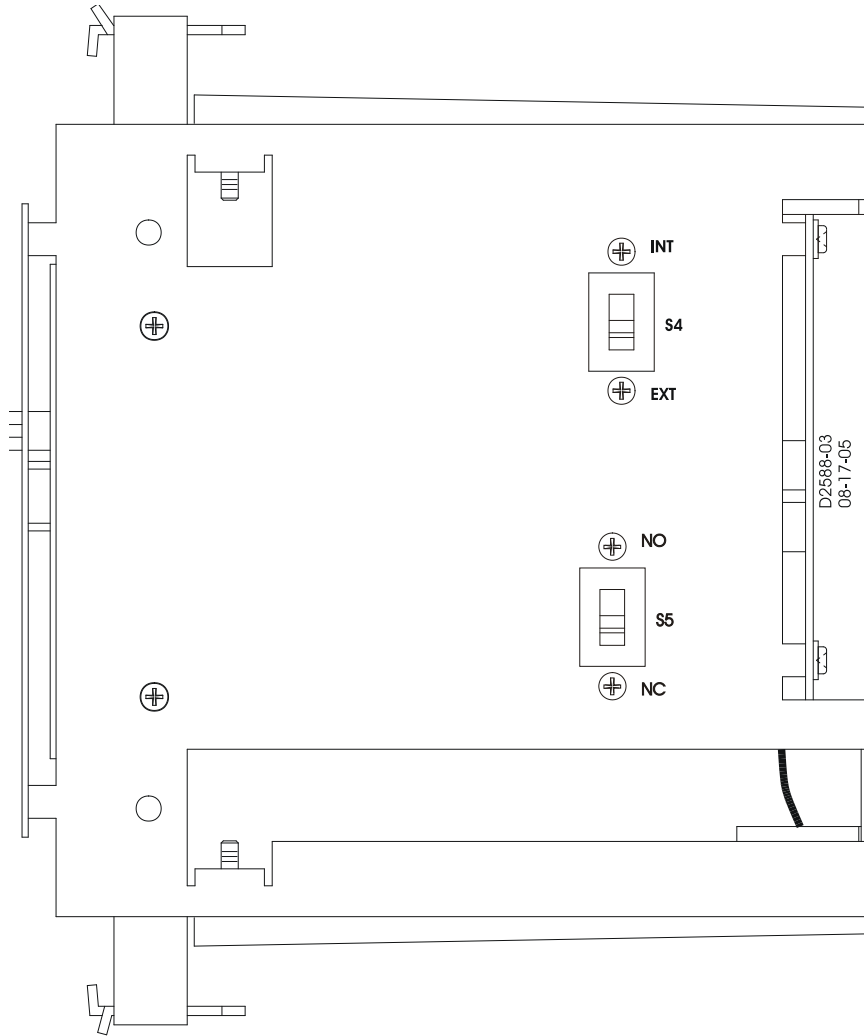

Figure 2-3. Instantaneous Reclose Jumper Switch and RS Contact Selection Switch



SECTION 3 • FUNCTIONAL DESCRIPTION

TABLE OF CONTENTS

SECTION 3 • FUNCTIONAL DESCRIPTION	3-1
Introduction	3-1
Hardware.....	3-1
100 Series Description	3-1
Circuit Operation	3-1
Inputs.....	3-1
Microprocessor.....	3-3
Outputs.....	3-3
Interconnections.....	3-4
Recloser Operation	3-5
Power-Up	3-5
Reset	3-6
Lockout.....	3-6
Reclosing Sequences.....	3-6

Figures

Figure 3-1. Function Block Diagram	3-1
Figure 3-2. Relay Interconnections for NLR-21U Applications.....	3-4
Figure 3-3. Power-Up Flow Chart.....	3-5
Figure 3-4. Reclose Settings Example	3-7
Figure 3-5. Reclosing Flow Chart.....	3-8

Tables

Table 3-1. Contact Sensing Jumpers	3-2
Table 3-2. Contact Sensing Inputs Description for NLR-21U Operation.....	3-2
Table 3-3. Outputs Description for NLR-21U Operation.....	3-3



SECTION 3 • FUNCTIONAL DESCRIPTION

Introduction

BE1-79A relays are microprocessor-based devices that provide automatic reclosing of circuit breakers. This section describes the hardware, circuitry, and software of the BE1-79A.

Hardware

The BE1-79A is supplied as an S2 cradle without a case (100 series).

100 Series Description

The BE1-79A-109 and -111 consist of a draw-out cradle assembly that is intended for installation in an existing S2 case. A case is not provided with the cradle assembly.

Circuit Operation

This description of circuit operation is divided into *Inputs*, *Microprocessor*, and *Outputs*. BE1-79A circuit functions are illustrated in Figure 3-1 and described in the following paragraphs.

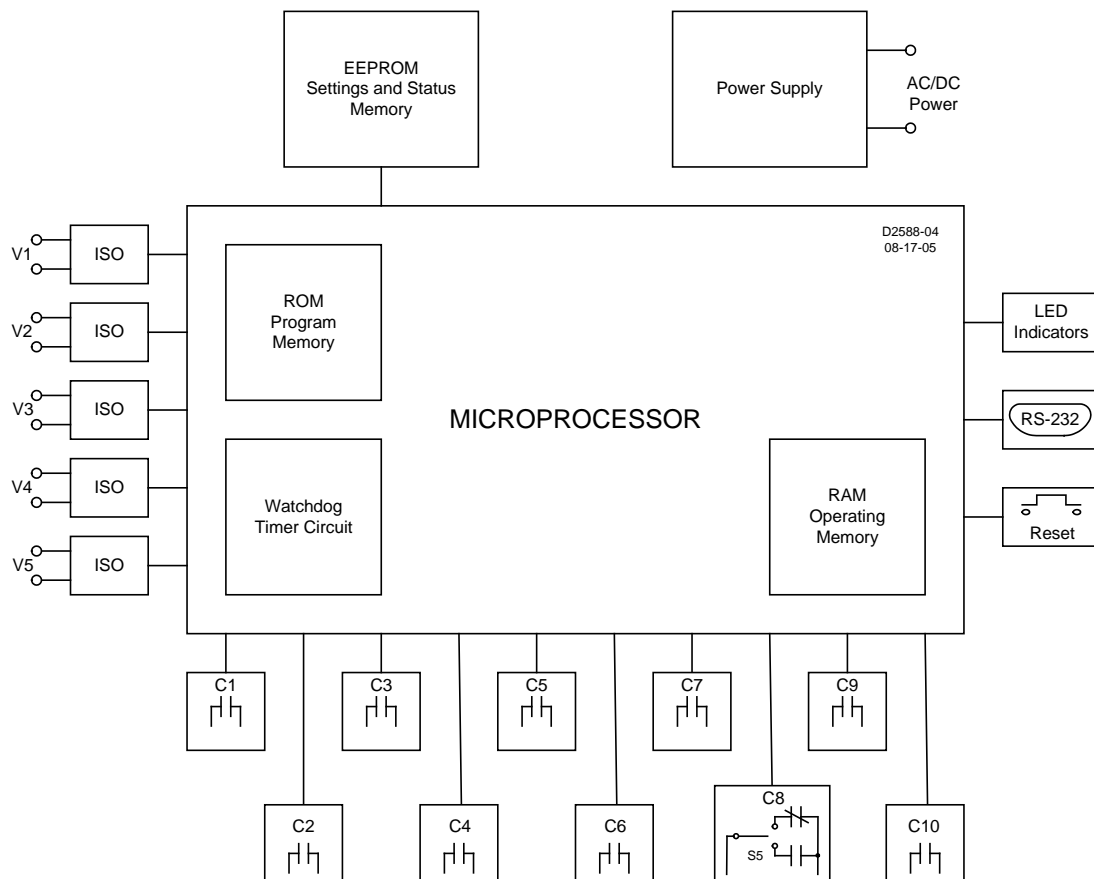

Figure 3-1. Function Block Diagram

Inputs

The four types of BE1-79A inputs are:

- Operating power
- Contact sensing inputs
- Reset switch
- Serial communication port

Operating Power

Operating power for the internal circuitry is applied to the internal, isolated, switching power supply. The power supply in the BE1-79A-109 operates over a range of 125 to 250 Vdc or 120 to 240 Vac with no connection changes or jumpers required. The power supply in the BE1-79A-111 operates over a range of 38 to 150 Vdc or 90 to 132 Vac with no connection changes or jumpers required. The operating power input is not polarity sensitive and is not disrupted by variations in the supply voltage or frequency over the power supply operating range. The power supply generates a 24 Vdc output.

Contact Sensing Inputs

The contact sensing inputs are designated V1, V2, V3, V4, and V5. Each input is optically isolated to electrically insulate the input from external power sources. Each contact sensing input is rated for 48 to 250 Vdc and 120 to 240 Vac at 45 to 65 hertz.

Inputs V1 through V4 can operate at any one of three jumper-selectable voltage ranges. Table 3-1 lists the nominal operating voltage for each of the jumper positions. Each input has a dedicated jumper that is located on the digital circuit board. Jumper P3 controls the operating voltage for V1, P4 controls V2, P5 controls V3 and P6 controls V4. Instructions for placing each jumper in the desired position are provided in Section 5, *Installation and Configuration*. Input V5 is dedicated to monitoring the relay power supply input and is not jumper selectable.

Table 3-1. Contact Sensing Jumpers

Jumper Position	Nominal Voltage
1	125 Vdc or 120 Vac
2	48 Vdc
3	250 Vdc or 240 Vac

The function of each input depends on the operating configuration of the relay. Table 3-2 describes the function of each contact sensing input. The GE nomenclature used for each input is provided in parenthesis following each description.

Table 3-2. Contact Sensing Inputs Description for NLR-21U Operation

Input	Terminals	Description
V1	3,4	Typically connects to a 52a contact, which results in voltage being sensed when the breaker is closed. If V1 senses voltage within three seconds after the Reset 1, 2, 3, or 4 timer expires, a reset will be initiated. If the relay is in lockout, a reset will be initiated anytime V1 senses voltage. (E Reset)
V2	6, 7	Voltage sensed at this input causes the relay to start a reclose sequence. (Motor)
V3	11, 12	Used to monitor the 52b contact while the relay is in a reset condition. When V3 senses voltage, the relay initiates a reclose sequence. (E Operate)
V4	11, 17	Connects to a 52b contact, which results in voltage being sensed when the breaker is open. This input is typically used to provide an anti-pump feature. If voltage is removed from V4 during a reclose attempt, the anti-pump feature will prevent a further reclose attempt until the next reclose set time is reached. This prevents multiple reclose attempts for a single reclose setting. (Z)
V5	5, 6	Internally connected to the relay power supply terminal. A loss of sensing voltage at this input causes all necessary data to be stored in memory and all contacts to return to their de-energized or "in-the-box" state.

Reset Switch

This momentary-action switch clears the front-panel In Sequence or Lockout LEDs and restores the relay to a rest condition. The reset switch performs the same function as the manual clutch release on the General Electric NLR-21U relay. Operating power must be applied to terminals 5 and 6 in order for a reset to occur.

Serial Communication Port

The communication port is a standard RS-232 (DB-9) female connector located on the front panel. This port provides the means to read and configure BE1-79A settings.

Microprocessor

All reclosing and communication functions are coordinated by the microprocessor. The BE1-79A uses an eight-bit microprocessor with integral ROM (read-only memory) and RAM (random access memory). The microprocessor is monitored by a watchdog circuit that resets the microprocessor if a problem is detected.

Outputs

The BE1-79A has 10 outputs. The function of each output depends on the operating configuration of the relay. Table 3-3 provides a description of each output.

Table 3-3. Outputs Description for NLR-21U Operation

Output	Terminals	Description
C1	12, 17	Closes momentarily when voltage is sensed at input V4 and the relay is in a reset condition. (Z2*E6)
C2	13, 14	Closed during reset and open when voltage at input V3 is sensed. During a reclose sequence, C2 remains open until the relay returns to reset. (E1)
C3	15, 16	Functions as a programmable alarm contact. Can be set to function as a relay fail output or a combination relay fail/lockout output. a detailed explanation is provided in Section 4, <i>Communication Commands, Command Descriptions, Alarm Output Command</i> .
C4	18, 19	Closed any time that the unit is not in reset. (E5)
C5	17, 19	Closes for three seconds after a reclose timer expires. (AB)
C6	14, 17	Anti-pump output. Closes for the duration of reclose timing except if output C5 closes. If C5 closes, output C6 will close only if voltage is sensed at contact sensing input V4. (BC*Z1)
C7	8, 20	Closed when the relay is in a lockout state. (HI)
C8	9, 10	RS output. Can be configured as a normally open (NO) or normally closed (NC) contact. Can be set to energize for an adjustable duration after the start of a reclose cycle. The interval between the start of a reclose sequence and C8 energizing is also adjustable. A detailed explanation of programming the RS output is provided in Section 4, <i>Communication Commands, Command Descriptions, RS Contact Setting Command</i> and Appendix A, <i>RS Contact Application</i> .
C9	5, 8	Closes when the relay is in reset and voltage is sensed at input V3. C9 remains closed until the relay reaches either a lockout or reset condition. (GH+E3)
C10	1, 2	Closed only during a reset condition. Opens and stays open when a reclose timing begins or is running. (E4)

Interconnections

Figure 3-2 illustrates the interconnection of the contact sensing inputs, relay outputs, style configuration switches, and instantaneous reclose jumper switch in the BE1-79A relay. The state of all relay output contacts is shown with all power removed from the relay.

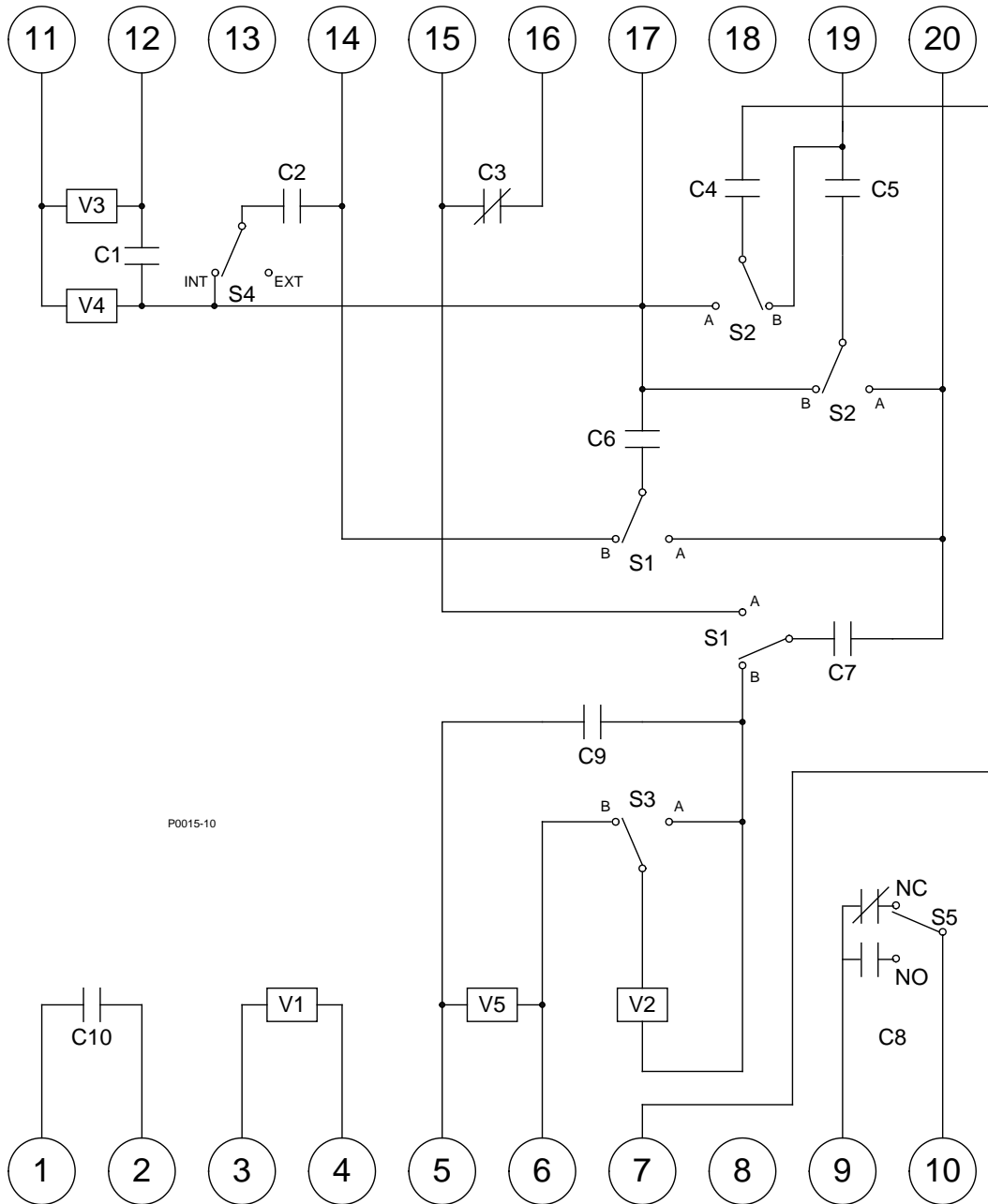

Figure 3-2. Relay Interconnections for NLR-21U Applications

Recloser Operation

Information about the software-controlled features of the recloser is provided in the following paragraphs.

Power-Up

The flow chart of Figure 3-3 describes relay operation following the application of operating power. Depending on conditions and the reset delay setting, the interval from power application to the resultant state may be from 0 to 300 seconds.

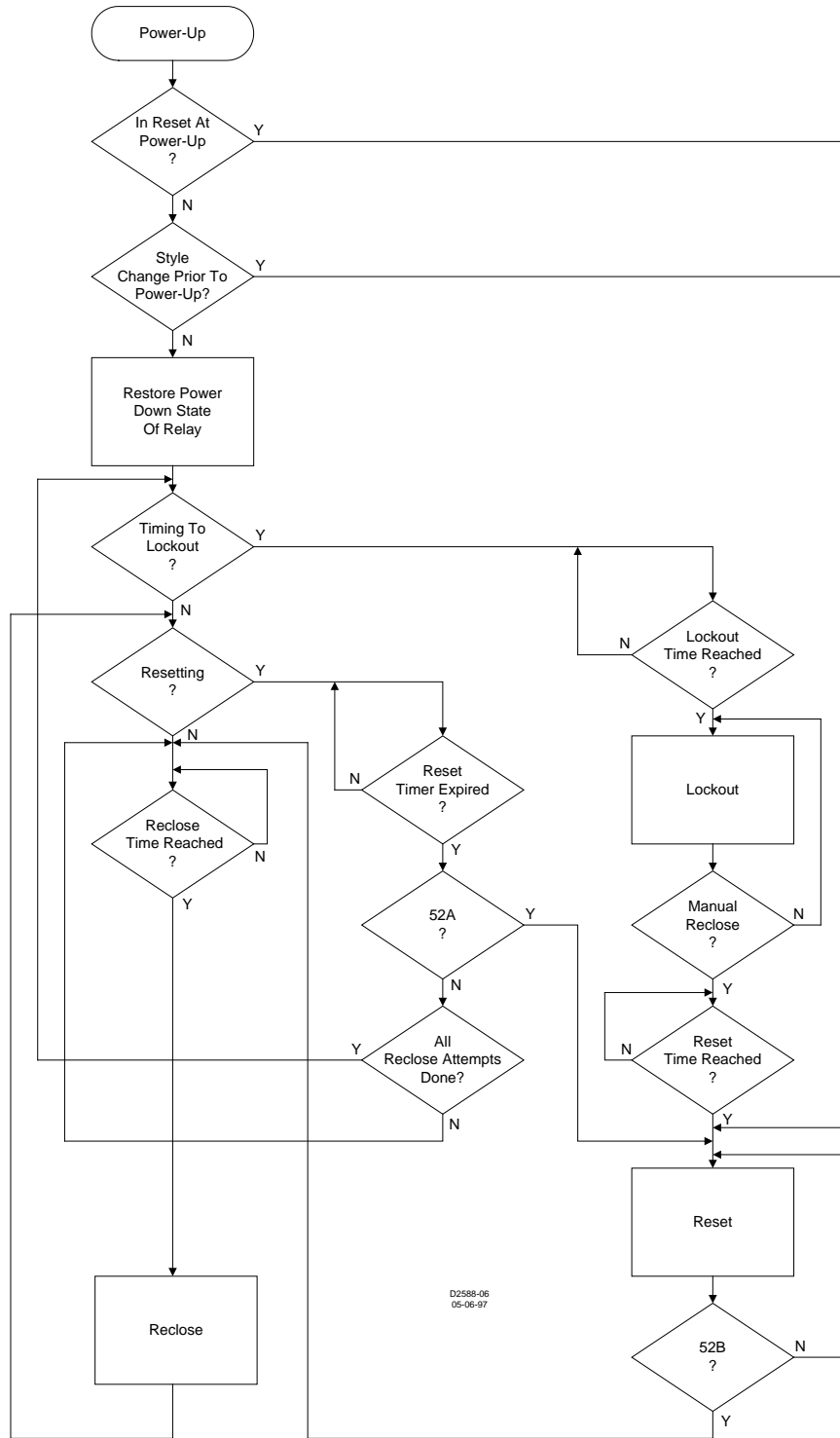

Figure 3-3. Power-Up Flow Chart

Reset

A reclosing sequence may be initiated only when the relay is in the reset state. Reset is indicated by the front panel Reset LED. In order for the relay to reach reset, the controlled breaker must be closed during a three-second period when the reset timer expires. If the breaker opens prior to this time, the relay will proceed to the next reclosing attempt. If the number of programmed reclosing attempts has been exhausted, the relay will drive to lockout.

A reset time of zero is used if no reset is desired after a specific reclosing attempt. As an example, for a first reclose/reset time delay setting of SP-79A1=10,0, the 0 indicates that the BE1-79A will not reset until after the next non-zero reset time. If the second reclose/reset time delay setting is SP-79A2=30,40, then the relay will reset at the 40 second point in the timing sequence.

Lockout

Lockout, a state inhibiting relay operation, may be produced by four conditions:

- Reclose failure
- Number of breaker openings exceeds the number of programmed reclosure attempts
- The EXIT command is entered to terminate RS-232 communication
- Communication access has timed out

Lockout is indicated by the front panel Lockout LED. The S-ALM command allows output C3 to be programmed to close for a lockout condition. Lockout is terminated when the controlled breaker is closed (manually or by other means) and remains closed for the duration of the final reset time delay setting.

Reclosing Sequences

A reclosing sequence is initiated by the closure of a 52b contact. A reclosing sequence is indicated by the In Sequence LED located on the front panel. The BE1-79A provides up to four automatic reclosures. Each reclose setting is adjustable and has a setting range of 0 to 300 seconds. The number of reclosing attempts may be limited by adjusting any one of the reclose time delay settings (after the first reclose) to zero. When a breaker trip occurs at this point in the reclosing sequence, the BE1-79A will time toward lockout. An instantaneous first reclose is enabled on BE1-79A relays configured for NLR-21U operation by placing instantaneous reclose jumper switch S4 in the "INT" position. Refer to Section 2, *Controls and Indicators*, for the location of switch S4. Do not connect a jumper wire between terminals 13 and 17 when an instantaneous first reclosure is desired. For a delayed first reclosure, place instantaneous reclose jumper switch S4 in the "EXT" position. Do not connect a jumper wire between case terminals 12 and 13 when a delays first reclosure is desired.

Each of the four reclose settings has a corresponding reset timer. A final reset controls the time between lockout and reset. Each reset setting is adjustable and has a setting range of 0 to 300 seconds. Pressing the front panel Reset pushbutton will clear a reclosing sequence and return the relay to the reset state.

Each reclose and reset timer setting begins at time zero when the breaker opens the first time and initiates the first reclose timer. Typically, this makes the first reclose setting the shortest time setting and the fourth reclose setting the longest time setting. Figure 3-4 illustrates a BE1-79A reclosing sequence and the relationship of each reclose setting to the breaker openings.

The flow chart of Figure 3-5 is a simplified representation of reclosing sequence initiation and progression.

If a reclosing sequence is interrupted by removing power supply voltage from terminal 5 or 6, this will "freeze" the timing cycle at that point in the reclosing sequence. Freezing the timing sequence will result in contact C10 and the RS contact returning to their de-energized state when the BE1-79A power supply is de-energized. Once voltage is restored to the power supply, timing resumes from the point in the reclosing sequence that the power supply was de-energized.

External restrictions such as "hot-bus, dead-line" should be connected between terminals 7 and 8 of the BE1-79A to avoid de-energizing the power supply and "freezing" the timing sequence.

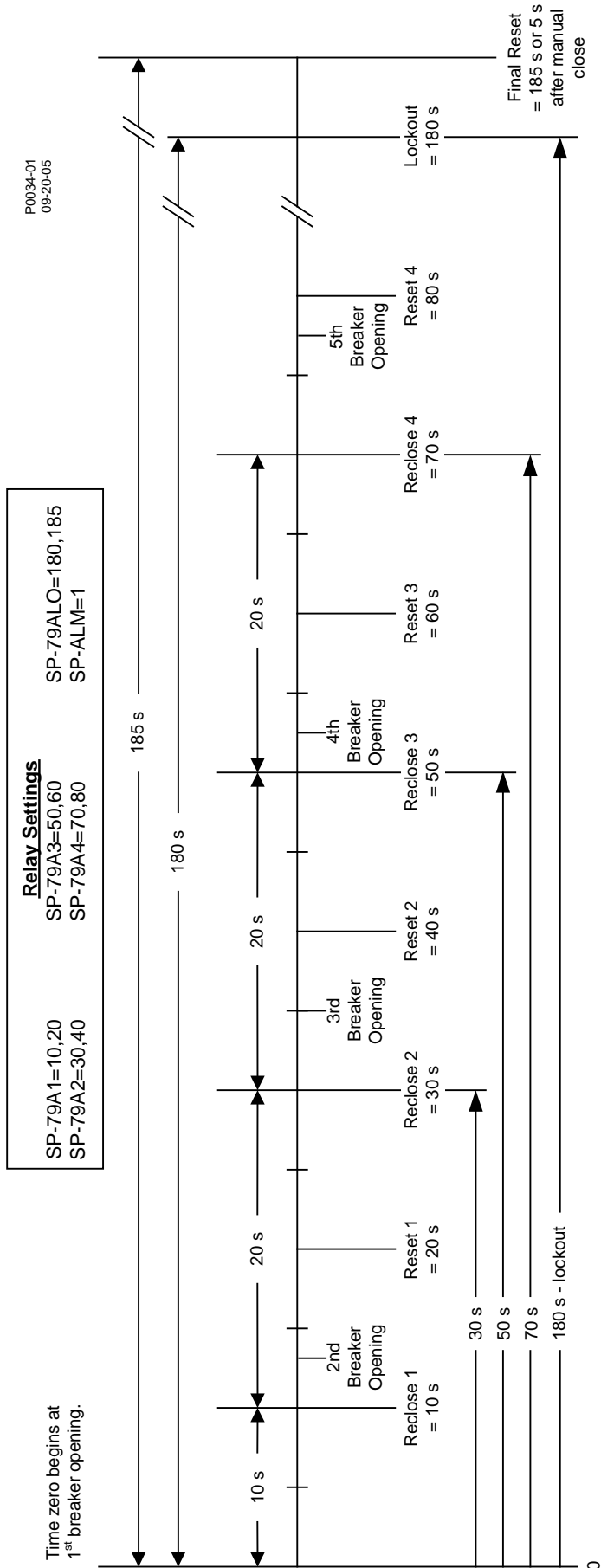

Figure 3-4. Reclose Settings Example

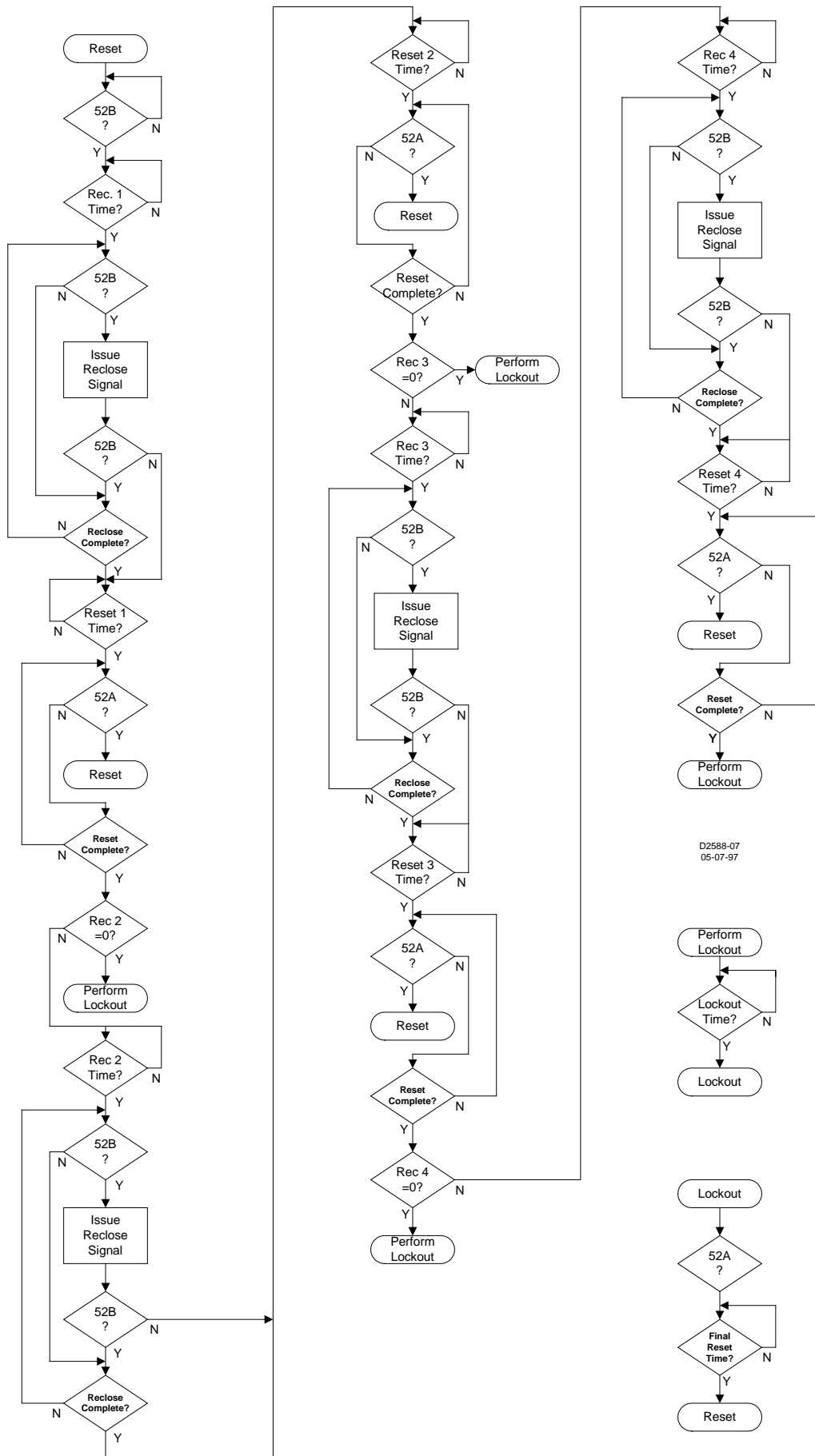

Figure 3-5. Reclosing Flow Chart

SECTION 4 • COMMUNICATION COMMANDS

TABLE OF CONTENTS

SECTION 4 • COMMUNICATION COMMANDS	4-1
Introduction	4-1
Communication Port Parameters.....	4-1
ASCII Command Format.....	4-1
Command Format	4-1
Command Response Format	4-1
Command Descriptions.....	4-2
Changing Settings through the Serial Port.....	4-2
Tables	
Table 4-1. Internal Default Settings	4-4



SECTION 4 • COMMUNICATION COMMANDS

Introduction

Communication commands are sent to the BE1-79A through a standard RS-232 (DB-9) connector located on the front panel. The BE1-79A ASCII communication protocol is compatible with readily available terminal/modem software such as the HyperTerminal application provided with the Windows® PC operating system. Information about configuring HyperTerminal and Terminal for communication with the BE1-79A is provided in Appendix B, *Terminal Communication*.

Communication Port Parameters

The following parameters apply to the BE1-79A communication port:

- Fixed baud rate of 9600
- Data bits fixed at 8
- Parity is fixed at NONE (N)
- Number of stop bits is fixed at 1
- Half duplex operation is supported

More information about BE1-79A communication interface requirements is provided in Section 5, *Installation and Configuration*.

ASCII Command Format

Each communication command, <CMD>, consists of an ASCII string terminated by a carriage return, <CR>. A line feed, <LF>, is optional.

Command Format

The BE1-79A uses a command format of <CMD>[<;>CMD...]<CR>[<LF>]. Command components are defined as follows.

[]	Brackets identify optional parameters. The brackets are not part of the command.
< >	Separators are used for clarity. The separators are not part of the command.
CMD	<name>[n][<=><setting-x>...[<,><setting-x>]]

Where:

Name	Command name. Refer to <i>Command Descriptions</i> for more information.
N	Optional command object. If more than one object is available and n is omitted, the command applies to all objects.
=	Used to indicate that the command is to change data or settings.
Setting-x	Command setting(s)
,	Commas are used as setting separators
CR	A carriage return is used to end a command and start command execution.
LF	A line feed may be used for clarity. It is ignored by the relay.
Spaces	One or more spaces may be added between entries for clarity if desired.

Command Response Format

The BE1-79A uses a command response format of [<response>][<ACK>]. Command components are defined as follows.

response	Determined by CMD.
ACK	">" is returned for a valid command, "?" is returned for an invalid command.

Commands received by the BE1-79A consist of two types: requests for information and changes to operating parameters. Commands to change parameters are identified by an equal sign (=). The operating parameters to the right of the equal sign are intended to replace the current operating parameters related to the command.

Some commands may pertain to multiple items. In that case, a numeric identifier is used after the command name to specify a single item. If the identifier is omitted, the command is applied to all possible items. For

example, the SP-79A1 command could be used to read the first reclose setting or the command S could be used to read all reclose settings.

Command Descriptions

BE1-79A command descriptions and examples are provided in the following paragraphs.

Changing Settings through the Serial Port

The ACCESS command is used to access write privileges while changing relay settings. Relay control functions are disabled when access is granted. Changing the settings through the serial port requires that the operator use the ACCESS command to obtain programming access. The operator enters ACCESS= and the relay responds with an acknowledgement of ACCESS GRANTED if the command was received and executed. Any time an invalid command is received, the relay will respond with a question mark (?).

The EXIT command is used to release write privileges while changing relay settings. After the changes are made, the new data will be copied to the working settings and saved to nonvolatile memory when EXIT is entered. The operator must confirm that the programming is completed and accepted before the changes are actually made. It is important to make all changes to relay settings before executing the EXIT command. This ensures that all intended settings are executed. The relay will go to the lockout state after the EXIT command is entered. If voltage is sensed at V1, the relay will return to the reset state after the lockout timer expires.

Changing settings through the serial port consists of the following sequence:

1. Enter ACCESS=<CR> or A=<CR>.
2. Enter the necessary commands to change the current settings.
3. Enter EXIT<CR> or E<CR> to clear access and save settings.
4. Enter Y (yes)<CR> to confirm save. Enter N (no) to continue using the old settings.

The <CR> characters placed after commands represent a carriage return or pressing the Enter key. For simplicity, they will no longer be shown. However, each line entered by the operator must be terminated with a carriage return <CR> or a carriage return–line feed <CR–LF>.

Access Command

ACCESS Command

Purpose: Read/set programming access in order to change user settings.

Syntax: ACCESS[=] or A[=]

Access must be changed by entering ACCESS= before any changes to the settings can be made. Relay protection functions are disabled when access is granted. The ACCESS command is valid for a period of five minutes if no new characters are entered. ACCESS by itself may be used to check if programming access is active or disabled. The relay will respond with ACCESS GRANTED or ACCESS: NO. The available access privilege is Privilege S: Setting Access. When exiting programming access, the relay will go to the lockout state after the EXIT command is entered. If voltage is sensed at V1, the relay will return to the reset state after the lockout timer expires.

Exit Command

EXIT Command

Purpose: Exit programming mode

Syntax: EXIT or E

Comments: Exits the programming mode and resets the programming access privilege to 0.

Changes are made to a scratchpad copy of the settings. After the changes are made, the new data will be saved to nonvolatile memory and the new, working settings will be initialized when control to make changes is released by entering the EXIT command. After entering EXIT, the user is prompted to confirm that the new data should be saved. The user has three options (Y or N or C). If Y is entered, the data will be saved. If N is entered, the changes will be cleared and the old settings will be restored. If C is entered, the EXIT command will be aborted and programming may continue. It is important to make all changes to relay parameters before executing the EXIT command. This ensures that all intended settings are executed.

For clarity in the examples, relay responses are printed in the `Courier` typeface.

EXIT command example: exit after making setting changes.

EXIT

```
>SAVE CHANGES (Y/N/C)?      Prompt to save (Y)es, discard changes (N)o, or (C)ontinue
>Y                            Confirmation to save changes
CHANGES SAVED                Confirmation that changes were saved
```

Obtaining Help Information Through the Serial Port

The HELP or H command provides general help information on command syntax and functionality when the manual is not available. Help is available only when the relay is in a reset state.

HELP Command

Purpose: Obtains help on using serial port commands.
Syntax: HELP or H
Comments: The HELP command returns a listing of all available commands along with the proper syntax for each command.

Obtaining a Summary of All Settings

All relay settings may be listed using the S command.

S Command

Purpose: Read all relay settings back to user.
Syntax: SP-79A[n]
Comments: S by itself may be used to read all relay settings. SP-79A[n] is used to read a specific setting. the S command can be used to make a record of the relay settings after they have been set.

S command example: Obtain a report of the relay settings.

```
A=
S
SP-79A1 5,10
SP-79A2 15,20
SP-79A3 25,30
SP-79A4 35,40
SP-79ALO 45,50
SP-79ARS D,0,5
SP-ALM 2
>
```

Reclose and Reset Timer Setting Command

SP-79A Command

Purpose: Read or change the reclose and reset timer settings.
Syntax: S[-79a[n][=<reclose time delay>,<reset time delay>]
Comments: n: reclose number of LO for lockout. See Table 4-1 for setting defaults.
reclose time delay: adjustable from 0 to 300 seconds in 0.1 second steps. A Reclose 1 setting of zero will cause an instantaneous first reclosure. A setting of zero for any other reclose time delay will disable the reclose shot and subsequent shots.
reset time delay: adjustable from 0 to 300 seconds in 0.1 second steps. A reset time delay setting of zero will cause the reset to be disabled. A reset time delay setting less than the reclose time setting will cause an immediate reset following the reclose attempt.

SP-79A command example: Read the second reclose and reset timer settings.

```
A=
SP-79A2
15.0,20.0
>
```

Lockout Timer Setting Command

SP-79ALO Command

Purpose: Read or change the lockout timer settings.

Syntax: SP-79ALO[=<lockout time delay>,<final reset time delay>]

Comments: lockout time delay: adjustable from 0 to 300 seconds in 0.1 second increments. A lockout time delay setting of zero will cause an instantaneous lockout when the breaker opens. A lockout time delay setting that is shorter than a reclose time delay setting will take priority and drive the relay to lockout.

Final reset time delay: adjustable from 0 to 300 seconds in 0.1 second increments. A final reset time delay that is equal to zero or is less than the lockout time delay setting will give an immediate reset following lockout and a manual reclose. See Table 4-1 for setting defaults.

Table 4-1. Internal Default Settings

Command	Default
SP-79A1	0.0,0.0
SP-79A2	0.0,0.0
SP-79A3	0.0,0.0
SP-79A4	0.0,0.0
SP-79ALO	0.0,15.0
SP-79ARS	E,1.5,15.0
SP-ALM	2

RS Contact Setting Command

SP-79ARS Command

Purpose: Read or change the RS contact settings.

Syntax: SP-79ARS[=<mode>,<apply time>,<remove time>]

Comments: mode: the state of the RS coil and contact, which can be D or E for the coil status.

D: de-energized RS coil. Second NO contact when terminals 5 and 6 are de-energized.

E: energized RS coil. Second NC contact when terminals 5 and 6 are energized.

apply time: time from the start of the reclose cycle until the RS contact is applied. The apply time is adjustable from 0 to 300 seconds in 0.1 second increments.

remove time: time from the start of the reclose cycle until the RS contact is removed. The remove time is adjustable from 0 to 300 seconds in 0.1 second increments. See Table 4-1 for setting defaults.

Refer to Appendix A for SP-79ARS command examples.

Alarm Output Command

SP-ALM Command

Purpose: Read or change the Lockout/Relay Fail output setting.

Syntax: SP-ALM[=<mode>]

Comments: mode: selects the operating mode of the alarm output, which can be 1 or 2.

1 selects Relay Fail

2 selects Relay Fail and Lockout (default setting)

Relay Information Command

RG-VER Command

Purpose: Read information about relay hardware/firmware configuration

Syntax: RG-VER

Comments: Transmitting the RG-VER command will cause the relay to respond with the relay model number and the firmware version and date.

SECTION 5 • INSTALLATION AND CONFIGURATION

TABLE OF CONTENTS

SECTION 5 • INSTALLATION AND CONFIGURATION	5-1
General	5-1
Mounting	5-1
Connections	5-1
Relay Settings	5-3
Application	5-3
Style Configuration Switches	5-3
Instantaneous Reclose Jumper Switch	5-3
RS Switch	5-3
Motor Voltage	5-3
Contact Sensing Inputs	5-3
Timing Cams	5-5
Fault Clearing	5-5
RS Contact	5-5
Alarm Output	5-6
Reset Switch	5-6
Communication Connections and Settings	5-6
Communication Connector	5-6
Communication Settings	5-7
Figures	
Figure 5-1. Relay Connections	5-2
Figure 5-2. Contact Sensing Jumpers	5-3
Figure 5-3. Contact Sensing Jumper Locations for 48 Vdc	5-4
Figure 5-4. Contact Sensing Jumper Locations for 125 Vdc or 120 Vac	5-4
Figure 5-5. Contact Sensing Jumper Locations for 250 Vdc or 240 Vac	5-5
Figure 5-6. PC to BE1-79A Connections	5-7
Tables	
Table 5-1. Relay Terminal Functions	5-1
Table 5-2. RS-232 Pin Functions	5-6



SECTION 5 • INSTALLATION AND CONFIGURATION

General

BE1-79A Reclosing Relays are delivered in sturdy cartons to prevent shipping damage. Upon receipt of a relay, check the model number against the requisition and packing list for agreement. Inspect for damage and, if there is evidence of such, file a claim with the carrier and notify the Basler Electric regional sales office, your sales representative, or the Technical Sales Support department of Basler Electric.

If the relay is not installed immediately, store it in the original shipping carton in a moisture- and dust-free environment.

Storage

This device contains long-life aluminum electrolytic capacitors. For devices that are not in service (spares in storage), the life of these capacitors can be maximized by energizing the device for 30 minutes once per year.

Mounting

Because the BE1-79A is of solid-state design, it does not have to be mounted vertically. Any convenient mounting angle may be chosen. The BE1-79A is available in an S2 cradle. The S2 cradle is intended for installation in an existing S2 case.

Connections

Incorrect wiring may result in damage to the relay. Be sure to use the correct input power for the power supply and the correct input voltage for the contact inputs. Connections should be made with a minimum wire size of 14 AWG. Prepare the relay and case for service by performing the following steps.

1. Place style configuration switches S1, S2, and S3 in the “B” position. Refer to Section 2, *Controls and Indicators*, for the location of these switches.
2. Remove the jumper wire connected to terminals 17 and 19 of the NLR-21U case. All other existing case wiring should be left intact, except as described in items 2 and 3 of *Relay Settings*.
3. Connect jumper wires between terminals 3 and 11 and between terminals 6 and 11 of the NLR case.
4. Connect a jumper wire between terminals 5 and 13 of the NLR case.
5. Connect a jumper wire between terminals 4 and 20 of the NLR case.

Relay connections are listed in Table 5-1 along with the function of each connection.

Table 5-1. Relay Terminal Functions

Terminal	Function
4	52a (+)
7	Close (+)
9, 10	RS Contact
11	Power Supply (–) *
13	Power Supply (+) *

- * P/N 9310200109 uses 125 Vdc operating power.
P/N 9310200111 uses 48 Vdc operating power.

Relay connections are shown in Figure 5-1.

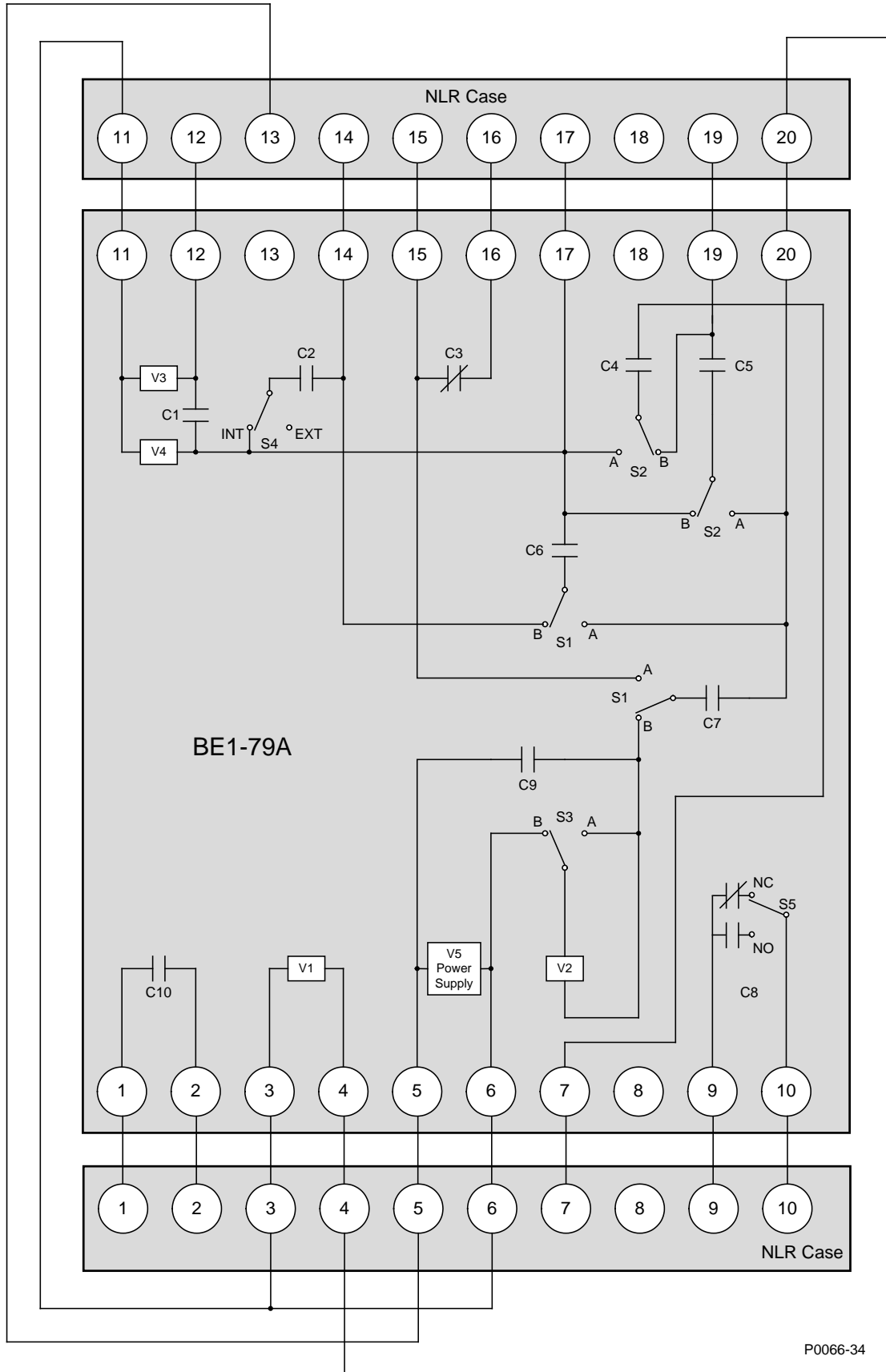

P0066-34

Figure 5-1. Relay Connections

Relay Settings

Observe the following guidelines when setting this modified BE1-79A relay.

1. The BE1-79A must be set to function like a GE NLR-21U relay.
2. For an instantaneous first reclosure, place instantaneous reclose jumper switch S4 in the “INT” position. Refer to Section 2, *Controls and Indicators*, for the location of switch S4. Do not connect a jumper wire between case terminals 13 and 17 when an instantaneous first reclosure is desired.
3. For a delayed first reclosure, place instantaneous reclose jumper switch S4 in the “EXT” position. Do not connect a jumper wire between case terminals 12 and 13 when a delayed first reclosure is desired.
4. Configure the relay settings by using the ASCII commands listed in Section 4, *Communication*.
5. The RS contact is configured with the SP-79ARS ASCII command.

Application

The intended function of the BE1-79A Reclosing Relay is to duplicate an NLR-21U recloser with only minor variations. To ensure that your BE1-79A relay functions properly, you should consider the adjustments and settings described in the following paragraphs.

- BE1-79A output contacts at case terminals 15 and 16 indicate a lockout alarm or relay failure. GE NLR-21U relay terminals 15 and 16 indicate a lockout alarm only.
- BE1-79A output contacts at case terminals 1 and 2 are available to indicate the recloser is functioning like a GE NLR-21U relay.

Style Configuration Switches

Switches S1, S2, and S3 must be set properly for your application. All three switches should be placed in the B (down) position for NLR-21U operation.

Instantaneous Reclose Jumper Switch

Refer to *Relay Settings* earlier in this section for instantaneous reclose jumper switch configuration.

RS Switch

RS switch S5 is used to control the RS contact for normally open or normally closed contact configuration. Figure 2-2 should be consulted for the location and setting positions of the style and configuration switches.

Motor Voltage

No adjustment is required for the motor voltage applied at terminals 5 and 6. The applied voltage can range from 120 to 240 Vac or 125 to 250 Vdc. These terminals serve as the input to the BE1-79A power supply and control functions.

Contact Sensing Inputs

Energizing levels for contact sensing inputs V1 through V4 are jumper selectable for operation at three nominal voltage levels. Jumper P3 controls the operating voltage for V1, P4 controls V2, P5 controls V3, and P6 controls V4. Nominal voltage levels of 125 Vdc/120 Vac, 48 Vdc, or 250 Vdc/240 Vac may be selected. Figure 5-2 illustrates the possible jumper positions for P3 through P6. Input V5 is dedicated to monitoring the relay power supply input and is not jumper selectable.

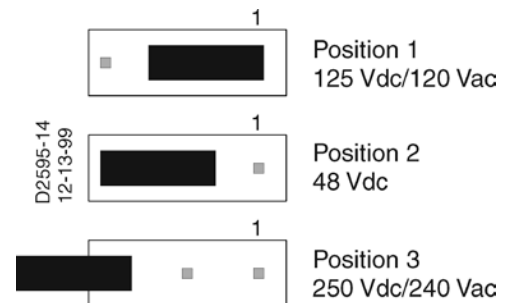

Figure 5-2. Contact Sensing Jumpers

NOTE

In certain applications where 240 Vac control voltage is used, control circuit feedback can occur through system inductive coupling. This feedback can result in erroneous signals, causing relay operation. If there is a potential for control circuit feedback, the jumper selectable voltage range should be changed from the 48 Vdc factory default setting to a higher position. Selections are provided in Table 3-1.

The following paragraphs describe how to locate and change the position of the contact-sensing jumpers.

1. Remove the four Phillips screws from the front panel and separate the front panel from the relay chassis.
2. Carefully grasp and remove the Digital circuit board (top circuit board) from the relay chassis. Take care not to damage any of the circuit board components. Observe all electrostatic discharge (ESD) precautions when handling the circuit board. Place the circuit board on an ESD-safe surface.
3. Locate the four jumper terminal blocks (P3 through P6) on the circuit board. The jumper terminal blocks are located on the component side of the circuit board near the rear contact fingers. Each terminal block has three pins and is factory installed on pins 2 and 3 for operation at 48Vdc. See Figure 5-3.

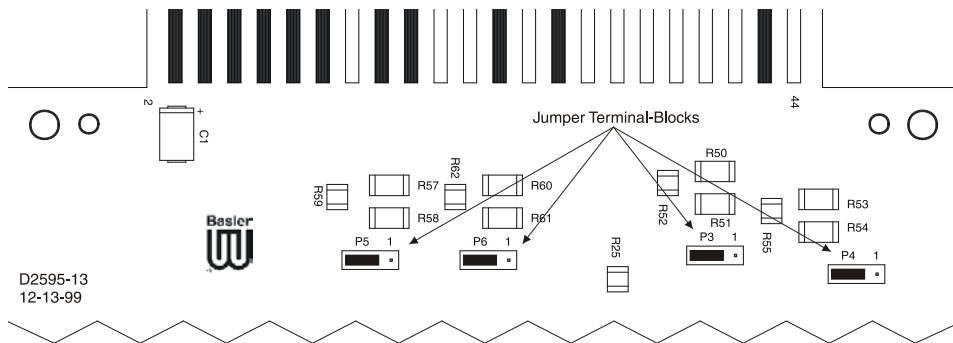

Figure 5-3. Contact Sensing Jumper Locations for 48 Vdc

4. To select operation at 125 Vdc or 120 Vac, remove the jumper from pins 2 and 3 and position it on pins 1 and 2. See Figure 5-4.

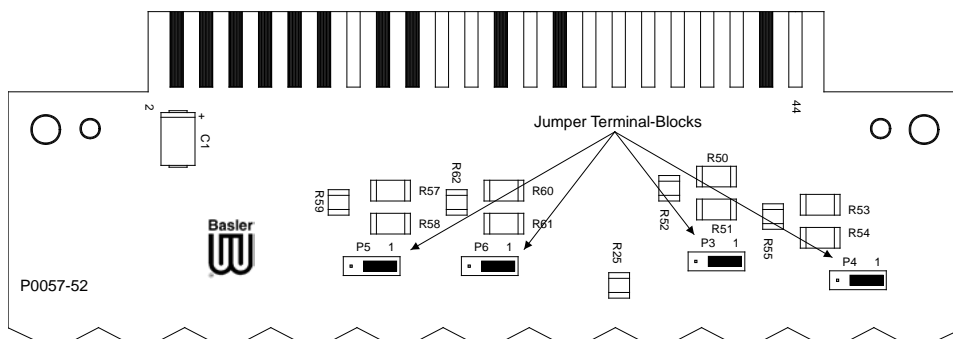

Figure 5-4. Contact Sensing Jumper Locations for 125 Vdc or 120 Vac

5. To select operation at 250 Vdc or 240 Vac, remove the jumper from pins 2 and 3 and position it on pin 3 for storage. (Only pin 3 should be covered.) See Figure 5-5.

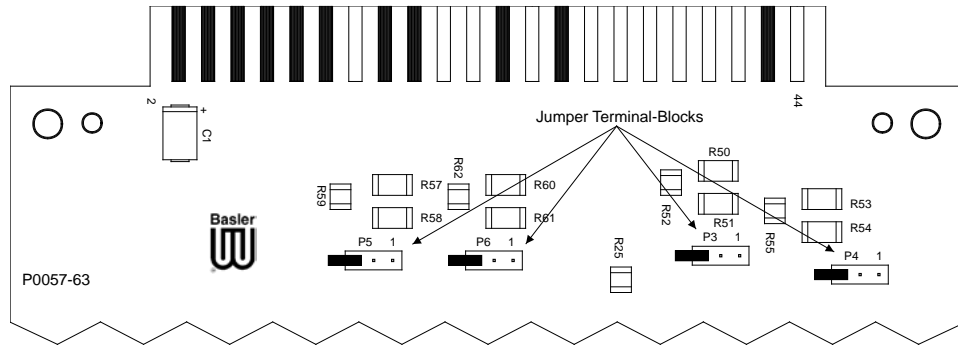

Figure 5-5. Contact Sensing Jumper Locations for 250 Vdc or 240 Vac

6. When all of the jumpers are positioned for operation in the desired sensing voltage range, prepare to place the circuit board back in the relay chassis.
7. Align the circuit board edges with the white guide markings on the relay chassis. Once aligned, slide the circuit board back into the chassis until the circuit board is seated in its connector. The front of the circuit board should be flush with the front of the relay chassis. (The LEDs and serial port connector will protrude past the front of the chassis.)
8. Place the front panel on the front of the relay chassis and align the four screw holes. Secure the front panel to the relay chassis with the four Phillips screws removed in step 1.

Timing Cams

Double-ended cams on NLR reclosers provide a 10 second reset after a reclosure. Single-ended cams can be adjusted for any reclose or reset time desired. The single- and double-ended cams of the NLR reclosers are simulated with the reclose and reset timer settings of the BE1-79A relay. Since the reclose and reset times for each of the four recloses is independently programmable, the function of the NLR reclosers can be duplicated.

NOTE

A reclose time delay must be set for a duration that is longer than the preceding reset time delay. Setting the reset time delay longer than the next reclose time delay in the reclose sequence will give undesired results.

Example:

<u>Incorrect</u>	<u>Correct</u>
SP-79A1=0,15	SP-79A1=0,7
SP-79A2=10,15	SP-79A2=10,15

Fault Clearing

The BE1-79A allows the first reclose to be delayed slightly so that faults may de-ionize before a reclosure is initiated. Faults typically are allowed to de-ionize for approximately 217 milliseconds (13 cycles) for distribution voltages and 300 milliseconds (18 cycles) for transmission voltages (including breaker-operating time). The inherent delay of the BE1-79A relay is 22 to 48 milliseconds when set at a time delay of zero. The reclose timers may be adjusted in increments of 0.1 seconds, which is 6 cycles on a 60-hertz system.

It is possible to set an NLR recloser for an instantaneous reclose with no voltage applied at terminals 5 and 6. If this unusual application is employed, the user must confirm that voltage is applied to BE1-79A terminals 5 and 6 when a reclose is desired. Terminals 5 and 6 must be energized for a reclose to be initiated.

RS Contact

A jumper is used in NLR reclosers to configure the RS contact for normally open or normally closed operation. In the BE1-79A, the RS contact is configured by switch S5. The SP-79RS command allows the RS contact operate and reset time to be programmed. Refer to Section 4, *Communication Commands, Command Descriptions* for a detailed description of the SP-79RS command.

Alarm Output

The SP-ALM command is used to program the alarm output to function as a relay fail output or a combination relay fail/lockout output. As a relay fail output, the alarm output will close if relay operating power is lost. The alarm output will also close if the microprocessor detects an abnormal condition such as the microprocessor is unsuccessful at storing settings in EEPROM.

If the microprocessor closes the alarm output due to a failure, all three front panel LED indicators will be lit. The failure indication can be cleared by cycling operating power to the relay.

Refer to Section 4, *Communication Commands, Command Descriptions* for a detailed description of the SP-ALM command.

Reset Switch

The front panel reset switch performs the same function as the manual clutch release in NLR reclosers. Power must be applied to terminals 5 and 6 for this function to perform a reset.

Communication Connections and Settings

The required connections and settings for BE1-79A communication are described in the following paragraphs.

Communication Connector

The BE1-79A uses a standard RS-232 (DB-9) female connector located on the front panel. Connector pin numbers, functions, names, and signal directions are listed in Table 5-2. Figure 5-6 provides a connection diagram for connecting the BE1-79A relay to a personal computer (PC).

Table 5-2. RS-232 Pin Functions

Pin	Function	Name	Direction
1	Shield	—	N/A
2	Transmit Data	TXD	From Relay
3	Receive Data	RXD	Into Relay
4	N/C	—	N/A
5	Signal Ground	GND	N/A
6	N/C	—	N/A
7	N/C	—	N/A
8	N/C	—	N/A
9	N/C	—	N/A

NOTE

The RS-232 communication ports are not equipped with request-to-send (RTS) and clear-to-send (CTS) control lines. This makes the BE1-79A incompatible with systems that require hardware handshaking or systems that use self-powered RS-232 to RS-485 converters connected to the RS-232 ports.

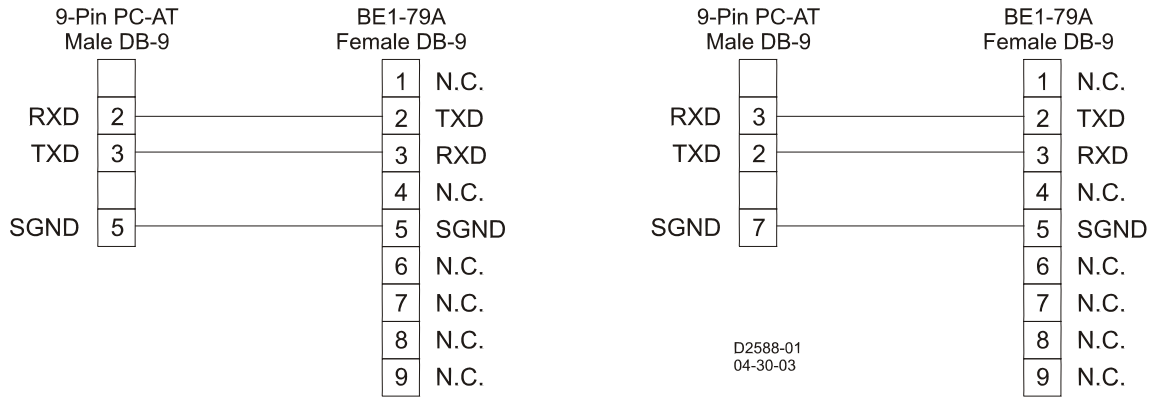

Figure 5-6. PC to BE1-79A Connections

Communication Settings

Communication settings are the formal set of conventions controlling the format and relative timing of message exchange between two communication terminals. The BE1-79A settings are fixed at 9600, 8N1, where 9600 is the baud rate, 8 is the number of data bits, N is the parity (none), and 1 indicates one stop bit. Since the communication settings of the relay are fixed, you must adjust your communication program settings to match the relay settings. Information about configuring Windows® HyperTerminal for communication with the BE1-79A is provided in Appendix B, *Terminal Communication*.



SECTION 6 • TESTING

TABLE OF CONTENTS

SECTION 6 • TESTING	6-1
Introduction	6-1
Instantaneous Reclose Testing.....	6-1
Delayed Reclose Testing	6-2
Troubleshooting Tips	6-4
Blinking LEDs	6-4
All LEDs On.....	6-4

Figures

Figure 6-1. Test Connections for NLR-21U Relays.....	6-3
--	-----

Tables

Table 6-1. Instantaneous Reclose Testing Commands	6-1
Table 6-2. Delayed Reclose Testing Commands.....	6-2



SECTION 6 • TESTING

Introduction

You may prefer to test your relay before installation. To test BE1-79A relay functionality, perform the procedures in the following paragraphs. Figure 6-1 illustrates the necessary connections for testing BE1-79A relays configured for NLR-21U operation.

CAUTION

Contact Sensing Input Jumpers must be set correctly before applying voltages. For more information, refer to Section 5, *Installation and Configuration, Application, Contact Sensing Inputs*.

Instantaneous Reclose Testing

Place Relay Style Configuration switches S1, S2, and S3 in the B position. Place Instantaneous Reclose Jumper switch S4 in the INT position. Place RS Contact switch S5 in the NO position.

1. Place Test switch S1 in the 52a position and apply 125 Vdc (BE1-79A-109) or 48 Vdc (BE1-79A-111) to the relay and test circuit.
2. Connect a PC with a serial port and suitable communication software to the relay serial port. Transmit the settings of Table 6-1 to the relay.

Table 6-1. Instantaneous Reclose Testing Commands

Command	Time Between Recloses
ACCESS=<cr>	N/A
SP-79A1=0.0,5.0<cr>	0 – 0 = 0s
SP-79A2=10.0,15.0<cr>	10 – 0 = 10s
SP-79A3=20.0,25.0<cr>	20 – 10 = 10s
SP-79A4=30.0,35.0 <cr>	30 – 20 = 10s
SP-79ALO=40.0,45.0<cr>	40 – 30 = 10s
SP-79ARS=D,19.39,0<cr>	N/A
EXIT<cr>	N/A
Y<cr>	N/A

3. Place Test switch S1 in the 52b position and observe that the following sequence of events occur.
 - a. Front panel Reset LED turns off
 - b. Reset indicator L1 turns off
 - c. Front panel In Sequence LED lights
 - d. Reclose indicator L2 will light immediately and remain lit for three seconds
 - e. After 10 seconds, L2 will light for three seconds
 - f. After 20 seconds, L2 will light for three seconds
 - g. After 30 seconds, L2 will light for three seconds
 - h. After 40 seconds, the front panel Lockout led and Lockout indicator L3 will light
4. Place Test switch S1 in the 52a position and observe that after five seconds, the front panel Reset LED and Reset indicator L1 light.
5. Place Test switch S1 in the 52b position. When Reclose indicator L2 lights, momentarily place Test switch S1 in the 52a position and verify that L2 turns off.
6. Place Test switch S1 in the 52b position and verify that after 10 seconds, L2 lights for three seconds.

7. Place Test switch S1 in the 52a position and verify that after 15 seconds, the front panel Reset LED and Reset Indicator L1 light.

Delayed Reclose Testing

Place Style Configuration switches S1, S2, and S3 in the B position. Place Instantaneous Reclose Jumper switch S4 in the EXT position. Place RS Contact switch S5 in the NO position.

1. Place Test switch S1 in the 52a position and apply 125 Vdc (BE1-79A-109) or 48 Vdc (BE1-79A-111) to the relay and test circuit.
2. Connect a PC with a serial port and suitable communication software to the relay serial port. Transmit the settings of Table 6-2 to the relay. (These settings correspond to the illustration of Figure 3-4.)

Table 6-2. Delayed Reclose Testing Commands

Command	Time Between Recloses
ACCESS=<cr>	N/A
SP-79A1=10.0,20.0<cr>	10 – 0 = 10 s
SP-79A2=30.0,40.0<cr>	30 – 10 = 20 s
SP-79A3=50.0,60.0<cr>	50 – 30 = 20 s
SP-79A4=70.0,80.0 <cr>	70 – 50 = 20 s
SP-79ALO=180,185<cr>	180 – 70 = 110 s
SP-79ARS=D,10,9<cr>	N/A
EXIT<cr>	N/A
Y<cr>	N/A

3. Place Test switch S1 in the 52b position and observe that the following sequence of events occur.
 - a. Front panel Reset LED turns off
 - b. Reset indicator L1 turns off
 - c. Front panel In Sequence LED lights
 - d. After 10 seconds, Reclose indicator L2 will light for three seconds
 - e. After 30 seconds, L2 will light for three seconds
 - f. After 50 seconds, L2 will light for three seconds
 - g. After 70 seconds, L2 will light for three seconds
 - h. After 180 seconds, the front panel Lockout led and Lockout indicator L3 will light
4. Place Test switch S1 in the 52a position and observe that after five seconds, the front panel Reset LED and Reset indicator L1 light.
5. Place Test switch S1 in the 52b position. When Reclose indicator L2 lights 10 seconds later, place S1 in the 52a position momentarily and verify that Reclose indicator L2 turns off.
6. Place Test switch S1 in the 52b position before 20 seconds elapse and verify that after 30 seconds, Reclose indicator L2 lights for three seconds.
7. Place Test switch S1 in the 52a position and verify that after 40 seconds, the front panel Reset LED and Reset indicator L1 light.

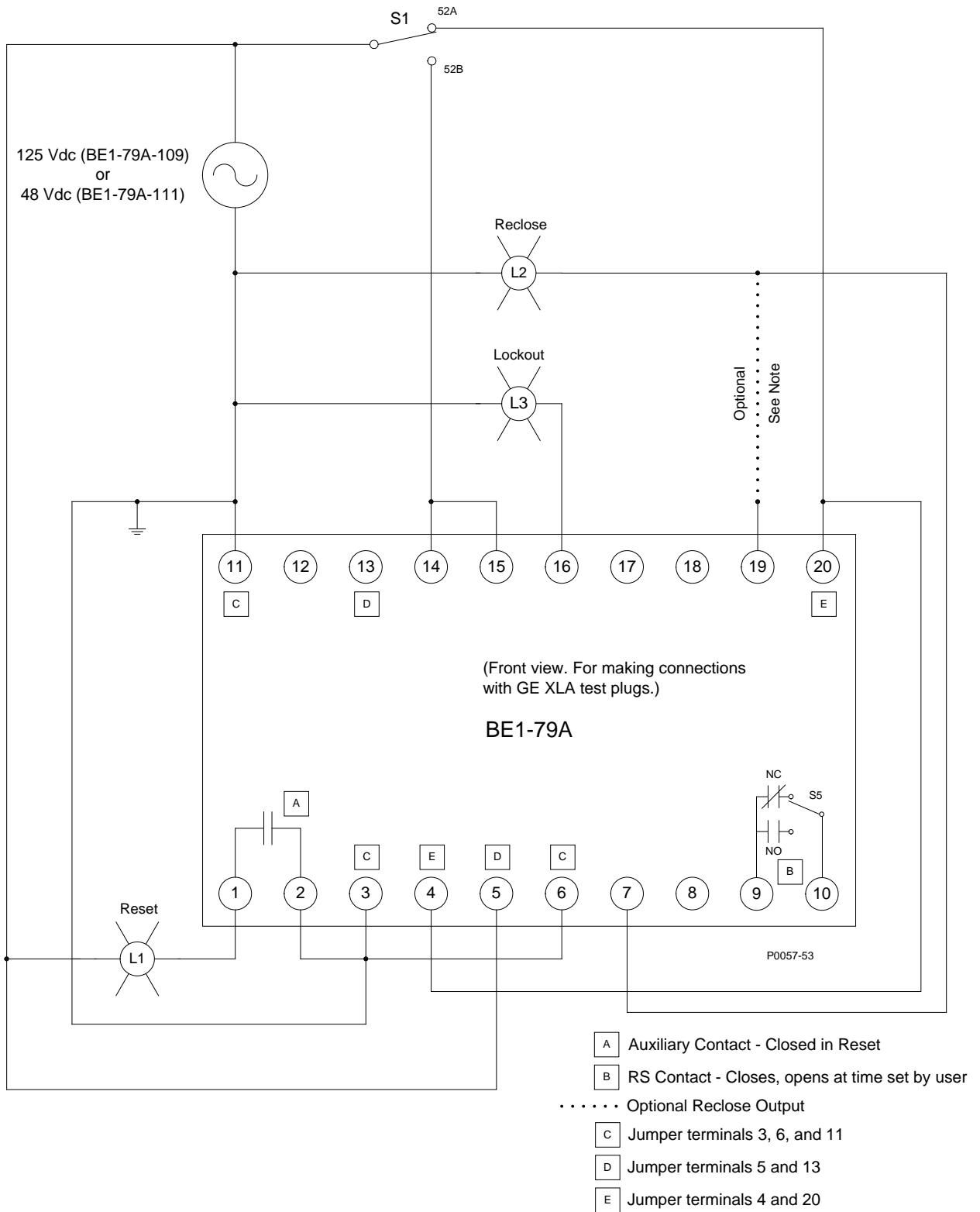

Figure 6-1. Test Connections for NLR-21U Relays

Troubleshooting Tips

The front panel LED indicators will annunciate certain conditions that will inhibit the BE1-79A relay from providing reclose protection.

Blinking LEDs

This annunciation indicates low or incorrect relay input voltage. Verify proper contact sensing jumper selection.

All LEDs On

This annunciation indicates an EEPROM error or recent cycling of relay operating power.

APPENDIX A • RS CONTACT APPLICATION

TABLE OF CONTENTS

APPENDIX A • RS CONTACT APPLICATION	A-1
Introduction	A-1
RS Contact Output State	A-1
RS Contact Settings.....	A-2
Mode D Example	A-2
Mode E Example	A-2
RS Contact Example for Transformer LTC Blocking	A-4
SP-79ARS Mode Selection	A-4
SP-79ARS Remove Time Selection.....	A-4
RS Contact Example for Blocking Instantaneous Overcurrent Tripping	A-4
Figures	
Figure A-1. RS Contact Setting Examples	A-3
Tables	
Table A-1. RS Contact Operation Table.....	A-1



APPENDIX A • RS CONTACT APPLICATION

Introduction

The functionality of the RS contact in the BE1-79A relay emulates that of an NLR reclosing relay. The RS contact can be applied to disable the instantaneous trip circuit of protection relays after any close attempt, typically leaving only time overcurrent protection in service. It can also be used to block transformer load tap changer (LTC) changes during a reclosing sequence. For transmission line applications, it has been used to permit operation of other automatic devices such as motor operated switches in line sectionalizing operations.

RS Contact Output State

To illustrate RS contact operation, Table A-1 lists the possible setting combinations for RS Contact switch S5 (NO or NC) and the SP-79ARS command mode (D or E). Switch S5 can be selected as normally open or normally closed to simulate the jumper-selectable RS contact in an NLR relay. Independent of the SP-79ARS command mode, the S5 NO/NC selection assigns the state of the RS contact when the relay power supply is de-energized.

Table A-1. RS Contact Operation Table

SP-79ARS Command Parameters	S5 Position	RS Contact State When:			
		BE1-79A Power Off	BE1-79A Reset	Applied	Removed
D,0,145	NC	Closed	Closed	Opens as soon as 52b makes	Closes at 145 s
D,2.5,145	NC	Closed	Closed	Opens at 2.5 s	Closes at 145 s
D,0,145	NO	Open	Open	Closes as soon as 52b makes	Opens at 145 s
D,2.5,145	NO	Open	Open	Closes at 2.5 s	Opens at 145 s
E,0,145	NC	Closed	Open	Closes as soon as 52b makes	Opens at 145 s
E,2.5,145	NC	Closed	Open	Closes at 2.5 s	Opens at 145 s
E,0,145	NO	Open	Closed	Opens as soon as 52b makes	Closes at 145 s
E,2.5,145	NO	Open	Closed	Opens at 2.5 s	Closes at 145 s

Table A-1 Notes

SP-79ARS command syntax is SP-79ARS[=<mode>,<apply time>,<remove time>]. Mode D indicates that the RS element is de-energized or “dropped out” when power is applied to BE1-79A terminals 5 and 6.

Mode E indicates that the RS element is energized or picked up when power is applied to BE1-79A terminals 5 and 6.

In Applied mode, the RS contact functions opposite of the way it does in Removed mode and BE1-79A Power Off mode.

When the ac or dc operating power applied to terminals 5 and 6 is interrupted during a reclose sequence, the RS contact returns to the BE1-79A Power Off state until operating power is restored and the reclosing sequence is resumed.

The mode of the RS contact offers the ability to invert the relay logic. In D (de-energized) mode, the position of the RS contact will follow the classic definition of relay logic:

- If RS logic is 0, the RS relay coil is de-energized.
- If RS logic is 1, the RS relay coil is energized.

In E (energized) mode, the relay logic is inverted and the RS coil is normally energized and then de-energized when the RS logic goes to 1. The effect is:

- If RS logic is 0, the RS relay coil is energized.
- If RS logic is 1, the RS relay coil is de-energized.

Note that if E logic is selected and the relay RS logic is 0, the RS coil will be energized and holding the output contact against its internal spring. However, if the relay loses power at this point, the RS contact will change state to the open/closed position dictated by RS Contact switch S5. Table A-1 is based on these explanations and will be referred to throughout the remainder of this appendix.

The BE1-79A Power Off state of the RS contact follows ac or dc operating power applied to terminals 5 and 6 and whether switch S5 is in the NC (normally closed) position or NO (normally open) position. If operating power is not applied to terminals 5 and 6 and the mode selected is D (de-energized), then the RS contact function, as selected by S5 (NC or NO), is just as if you were measuring contact continuity across terminals 9 and 10 with the relay sitting on a test bench with no wiring connected. If the mode is E (energized), then operating power must be present at terminals 5 and 6 to hold the RS contact in its desired position at the BE1-79A's reset position.

RS Contact Settings

The RS contact setting command, SP-79ARS, determines the mode, apply time, and remove time of the RS contact. SP-79ARS command syntax is SP-79ARS[=<mode>,<apply time>,<remove time>].

The mode setting indicates the state of the RS element when:

- The relay has operating power applied to terminals 5 and 6
- The BE1-79A relay is in Reset while the RS contact Remove time expired

A mode setting of D will de-energize the RS element during the conditions indicated above. A mode setting of E will energize the RS element for the conditions indicated above. An Apply time set at zero is applied as soon as the circuit breaker 52b contact makes. An Apply time set at a value other than zero begins its timing sequence as soon as the breaker opens on its first trip and the 52b contact makes. Remove time also begins when the 52b contact makes for the first time in a reclose sequence and lasts until its programmed Remove time is reached or the breaker successfully recloses and the BE1-79A returns to Reset.

Examples of four different RS contact configurations and settings are shown in Figure A-1 and explained in the following paragraphs.

Mode D Example

From Table A-1, for mode D settings, an NC RS contact (S5 = NC, mode = D) will be closed during BE1-79A power-off and will remain closed when the BE1-79A relay is powered on. (This assumes that the Remove time from a previous reclose cycle has expired or the relay is in Reset.) The NC contact will remain closed until a reclose cycle begins and the RS contact Apply time is reached. The NC contact will then open and remain open until the RS contact Remove time is reached. (If operating power is lost at terminals 5 and 6 during this time, the NC contact will close as indicated in Table A-1, BE1-79A Power Off).

When the Remove time expires, the NC contact will again close and remain closed until a new reclose cycle is started. For SP-79ARS=D,0,145, as soon as the circuit breaker 52b contact makes following the first trip, the RS contact will open and remain open until a time of 145 seconds where it will open and remain open until a time of 145 seconds where it will again close. For SP-79ARS=D,2.5,145, the RS contact will remain closed for 2.5 seconds after the circuit breaker 52b contact closes for the first trip-out and then be open until the 145 second time is reached or reset occurs. If the BE1-79A goes to reset before the Remove time is reached, the RS contact changes back to its state at reset without having to time to the Remove time setpoint.

From Table A-1, for mode D settings, an NO RS contact (S5 = NO, mode = D) will be open during BE1-79A power-off and will remain open when the BE1-79A is powered on. (This assumes the Remove time from a previous reclose cycle has expired or the relay is in Reset.) The NO contact will remain open until the reclose cycle begins. At that time, the NO contact will continue to remain open until the RS contact Apply time is reached. The NO contact will then close and remain closed until the RS contact Remove time is reached. (If relay power is lost during this time, the NO contact will open.) When the Remove time expires or the BE1-79A resets, the NO contact will again open and remain open until the next reclose cycle.

Mode E Example

From Table A-1, for mode E settings, an NC RS contact (S5 = NC, mode = E) will be closed during BE1-79A power-off and will be energized and opened when the BE1-79A is powered on and in Reset. The NC contact will remain open until the reclose cycle begins. At that time, the NC contact will continue to remain open until the RS Apply time is reached. The NC contact will then close and remain closed until the RS contact Remove time is reached. (If relay power is lost during this time, the NC contact will remain closed.)

When the Remove time is reached or the BE1-79A resets, the NC contact will again open and remain open until the next reclose cycle begins from the Reset position.

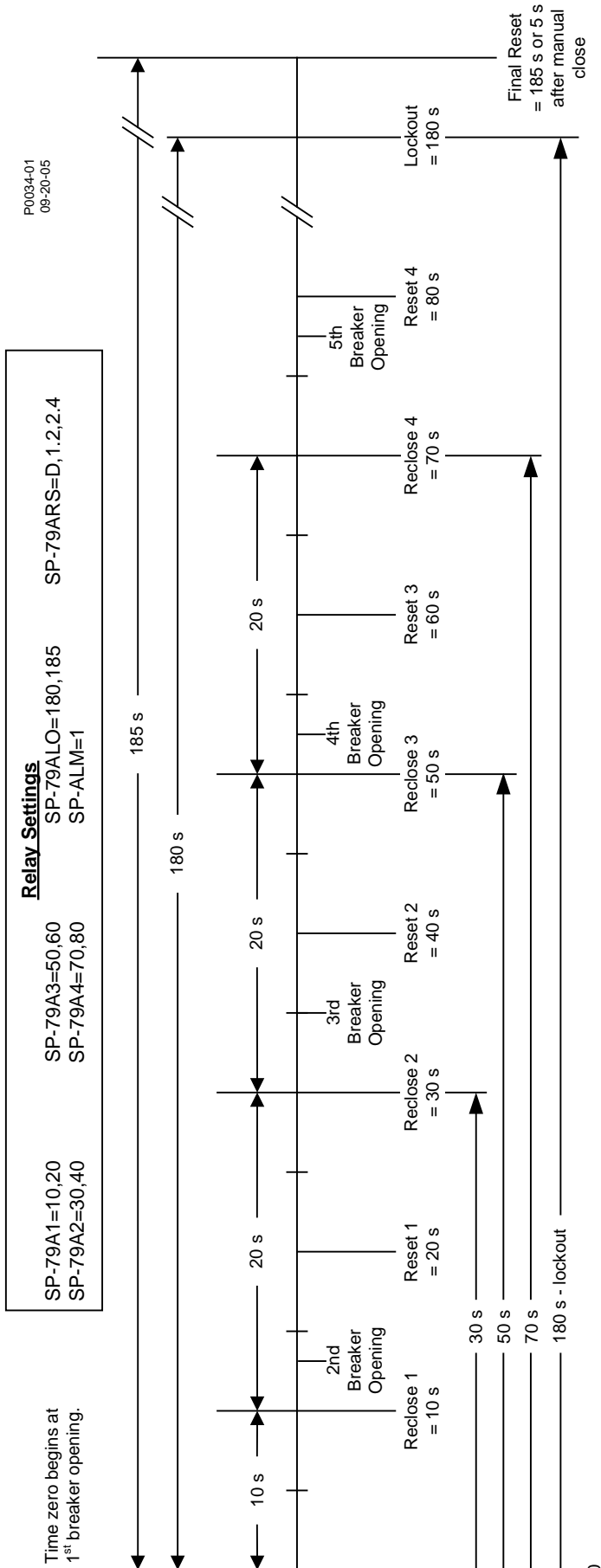

Figure A-1. RS Contact Setting Examples

From Table A-1, for mode E settings, an NO RS contact (S5 = NO, mode = E) will be open during BE1-79A power-off and will be energized and closed when the BE1-79A relay is powered on and in Reset position. The NO contact will remain closed until the reclose cycle begins. At that time, the NO contact will continue to remain closed until the RS Apply time is reached. The NO contact will then open and remain open until the RS contact Remove time is reached. (If relay power is lost during this time, the NO contact will remain open.)

When the Remove time is reached or the BE1-79A resets, the NO contact will again close and remain closed until the next reclose cycle begins from the Reset position.

RS Contact Example for Transformer LTC Blocking

SP-79ARS Mode Selection

If using the de-energized mode (mode = D), be aware that the RS contact will revert to the de-energized state during loss of BE1-79A operating power. Therefore, if power is lost during the reclose cycle, the NO RS contact (S5 = NC) being held open to block the LTC will change state and remove the LTC blocking while the relay is without power. If a reliable dc power source to terminals 5 and 6 is available, it will prevent this from occurring.

If using the Energized mode (mode = E) and the normally open RS contact (S5 = NO), it will revert to the de-energized state during loss of BE1-79A operating power. If operating power is lost during the reclose cycle, the NO RS contact being held open to block the LTC will remain open and continue the block. If the relay power to terminals 5 and 6 is lost at any other time (during breaker maintenance, a common dc power source may be turned off), the RS contact will change state and block the LTC, which may be undesirable under these circumstances. Awareness of this condition will enable the user to take the necessary steps to prevent the condition from occurring.

SP-79ARS Remove Time Selection

The RS contact Remove time, when used for LTC blocking, should be long enough to allow a complete reclose cycle to occur but shorter than the final closure's reset time and before lockout time is reached. This ensures that the RS contact is blocking LTC operation during the reclose sequence but is reset to its normal condition before the next reclose cycle begins. The LTC will then be functioning normally even when the breaker has operated to the lockout condition.

RS Contact Example for Blocking Instantaneous Overcurrent Tripping

The BE1-79A has the following settings with switch S5 set for NC:

SP-79A1=0,10
SP-79A2=15,25
SP-79A3=45,55
SP-79A4=0,0
SP-79ALO=60,65
SP-79ARS=D,5,58
SP-ALM=2

With the NC (in de-energized mode) BE1-79A RS contact wired in series with an instantaneous over-current (50) device trip circuit, it will open or block tripping of a circuit breaker by the 50 element five seconds after the first trip of the breaker. The BE1-79A is programmed to close the breaker instantly for its first close (SP-79A1=0,10). If the breaker trips a second time before 10 seconds have elapsed, the BE1-79A RS contact will open at the Apply time setting of five seconds and remain open until the Remove time of 58 seconds from the first trip is reached. This will permit the 50 element to be in service when the breaker is closed after lockout.

If the breaker successfully closes on any of the three programmed close times of up to 45 seconds from the first trip and resets, then the Remove time also will be reset. Resetting the Remove time will restore the RS contact to its original NC position and restore the 50 element tripping for the next fault occurrence and trip-close sequence of the circuit breaker.

If the 50 element is to remain blocked when the BE1-79A is in lockout, then the RS contact Remove time should be set for 65 seconds also (SP-79ARS=D,5,65).

APPENDIX B • TERMINAL COMMUNICATION

TABLE OF CONTENTS

APPENDIX B • TERMINAL COMMUNICATION.....	B-1
Windows® 2000/XP	B-1
Windows® Vista.....	B-4

Figures

Figure B-1. Connection Description Dialog Box	B-1
Figure B-2. Connect To Dialog Box.....	B-2
Figure B-3. COM Properties Dialog Box	B-2
Figure B-4. Properties, Settings Tab	B-3
Figure B-5. ASCII Setup Dialog Box.....	B-4

Tables

Table B-1. RS-232 Communication Ports	B-4
---	-----



APPENDIX B • TERMINAL COMMUNICATION

Windows® 2000/XP

HyperTerminal (provided with Windows® 2000/XP) or other stand-alone software can be used to communicate with a BE1-79A relay. The following instructions are used for configuring HyperTerminal in Windows® 2000/XP to communicate with your BE1-79A relay. The configuration of other stand-alone software is similar.

Step 1: Click Start: Highlight Programs, Accessories, Communication, HyperTerminal.

Step 2: Click HyperTerminal to open the folder.

Step 3: Select the file or icon labeled Hypertrm or Hypertrm.exe. Once the program has started, you will be presented with a series of dialog boxes.

Step 4: Dialog Box: Connection Description

- a. Type the desired file name, for example, BE1-79A. See Figure B-1.
- b. Click "OK".



Figure B-1. Connection Description Dialog Box

Step 5: Dialog Box: Connect To

- a. Click the Connect using: drop-down menu. See Figure B-2.
Select Direct To COMx, where x is the port you are using on your computer.
- b. Click "OK".



Figure B-2. Connect To Dialog Box

Step 6: Dialog Box: COMx Properties

- a. Make the following selections using Figure B-3 as a guide:
 - Set the bits per second setting so that it matches the setting of the relay. The default baud rate of the relay is 9,600.
 - Set the Data bits at 8.
 - Set the Parity to None.
 - Set the Stop bits at 1.
 - Set Flow control to Xon/Xoff.
- b. Click "OK". This creates an icon with the file name entered in Step 4 and places it in the HyperTerminal folder. Future communication sessions can then be started by clicking the appropriate icon.

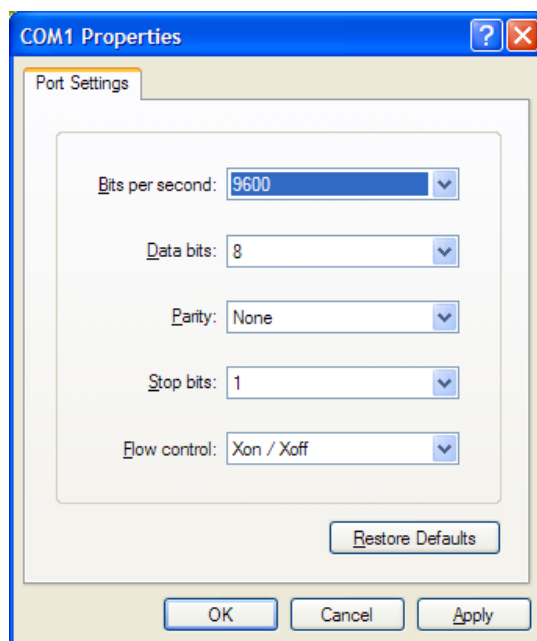

Figure B-3. COM Properties Dialog Box

Step 7: Click File/Properties on the menu bar. Click the Settings tab.

- a. Make the following selections using Figure B-4 as a guide:
Check the Terminal Keys radio button.
Select VT-100 emulation.
Set Backscroll buffer lines to the maximum setting of 500.

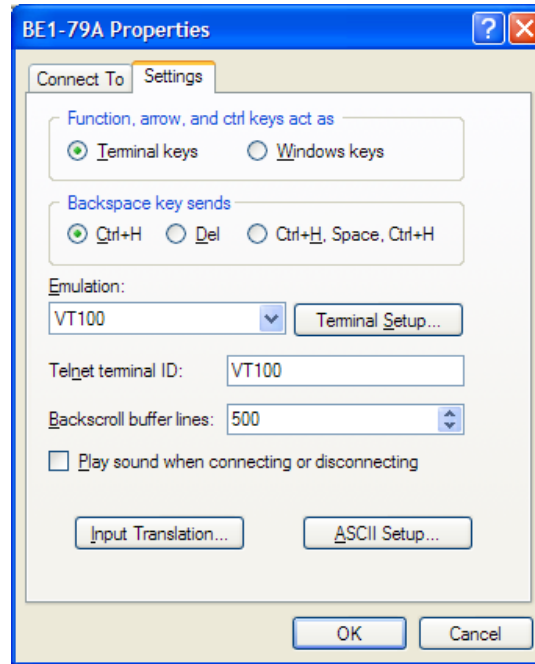

Figure B-4. Properties, Settings Tab

- b. Click the ASCII Setup button. Make the following selections using Figure B-5 as a guide:
ASCII Sending
Place a check at Send line ends...
Place a check at Echo typed characters...
Set the Line delay setting to 100 milliseconds.
Set the Charity delay setting to 0 milliseconds.
ASCII Receiving
Disable Append line feeds...by leaving the box unchecked.
Disable Force incoming... by leaving the box unchecked.
Place a check at Wrap lines...
 - c. Click "OK".
 - d. Click "OK".

Step 8: Click File and click Save.

NOTE

Settings changes do not become active until the settings are saved.

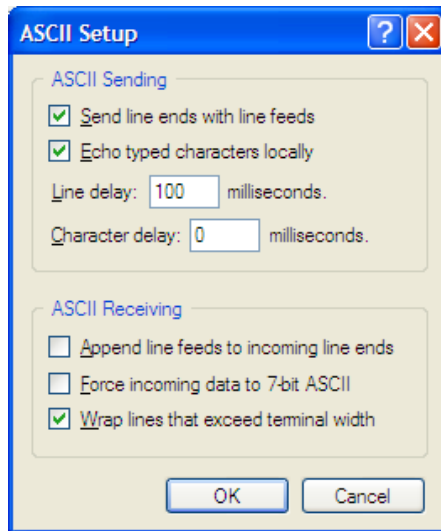

Figure B-5. ASCII Setup Dialog Box

Step 9: HyperTerminal is now ready to communicate with the relay. Table B-1 describes the required connection for the RS-232 port.

Table B-1. RS-232 Communication Ports

Connection	Type
Front Port	9-pin female DCE
PC to Front RS-232 port cable	Straight

Windows® Vista

HyperTerminal is not provided with Windows® Vista. Stand-alone software from other vendors can be used to communicate with a BE1-79A relay. The configuration of stand-alone software is similar to that of HyperTerminal.

 **Basler Electric®**
www.basler.com

12570 Route 143
Highland IL 62249-1074 USA
Tel: +1 618.654.2341
Fax: +1 618.654.2351
email: info@basler.com

No. 59 Heshun Road Loufeng District (N)
Suzhou Industrial Park
215122 Suzhou
P.R. CHINA
Tel: +86 512.8227.2888
Fax: +86 512.8227.2887
email: chinainfo@basler.com

111 North Bridge Road
15-06 Peninsula Plaza
Singapore 179098
Tel: +65 68.44.6445
Fax: +65 68.44.8902
email: singaporeinfo@basler.com