

Application Note

Implementing Generator Control with Local and Remote DGC-2020HD Controllers for Redundant Start/Stop, Metering, and Protection Capabilities

In certain situations, redundant DGC-2020HD controllers may be desirable for metering, protection, and control.

Multiple DGC-2020HD controllers might be of benefit in any system where normal operation of equipment occurs at a different location than that of the generator's local DGC-2020HD. An example might be a ship with a DGC-2020HD in the engine room and a second DGC-2020HD on the bridge or control cabin. Both locations should provide start/stop capability of the generator, metering of engine and generator parameters, and system protection. In addition, detection and annunciation of system alarms or pre-alarms is required.

The unit at the generator is denoted as the "generator local DGC-2020HD" and the unit in the remote location is denoted as the "remote DGC-2020HD" for the remainder of this document.

Redundant Functionality

The generator local DGC-2020HD and the remote DGC-2020HD can be configured to offer a degree of redundant functionality.

Redundant Off/Run/Auto Control

The DGC-2020HD BESTlogic™Plus Programmable Logic scheme and Distributed Broadcast Logic presented in this document can be used to achieve redundant Off/Run/Auto control. Once implemented, pressing the Off button on either unit will place both units in Off mode; pressing the Auto button on either unit will place both units in Auto mode; and pressing the Run button on either unit will place both units in Run mode.

Redundant Metering

In order to achieve redundant metering, the DGC-2020HDs must be wired so they both have access to all pertinent metering information. This can be implemented by:

- Parallel wiring of the Generator PTs to each DGC-2020HD.
- Series wiring of the Generator CTs through both DGC-2020HDs.
- Connecting both DGC-2020HDs to the engine Canbus communications network.

Note 1: Non-Canbus Applications

In non-canbus applications, it is not possible to wire the senders to two DGC-2020HDs, so direct metering of engine sender information cannot be implemented in the remote DGC-2020HD. In such systems, the remote DGC-2020HD will provide start/stop capability along with metering and protection of generator parameters. The remote DGC-2020HD will not be able to meter engine parameters other than engine speed. All engine protection other than speed related protection in the remote DGC-2020HD should be disabled. In addition, the Generator Speed Source setting in the remote unit should be set to "Gen Freq" in any non-canbus systems. Generator protection can be set up in the remote panel as well.

Note 2: Canbus Applications

In Canbus applications, the remote unit must have Canbus enabled and the ECU Configuration setting should be set to the same value as it is in the generator DGC-2020HD. However, the Engine Control Parameter Transmit setting should be set to "Disabled" because most ECU's do not support multiple generator set controllers. In such systems, the local DGC-2020HD provides start/stop capability along with metering and protection of generator parameters. The remote unit also provides start/stop capability and can provide a secondary level of engine and generator protection.

Redundant Protection

Since there are two DGC-2020HD units in the system, they can both be utilized to provide redundant protection of the generator. The generator local DGC-2020HD is configured to provide the primary protection. The remote DGC-2020HD should be set to less stringent protection levels than those in the generator local DGC-2020HD. If both units are set to the same levels, it is unclear which unit would trip first on a given fault condition, leading to possible confusion. It is recommended that different levels be set in the two units so that the remote DGC-2020HD provides protection only in the event that the generator local DGC-2020HD fails to detect a fault condition. Thus, in normal operation, the generator local DGC-2020HD

provides the primary protection. Any time system alarms or pre-alarms are annunciated, the generator local DGC-2020HD should be checked to see what caused the alarm or pre-alarm annunciation.

System Alarm and Pre-Alarm Handling and Annunciation

As recommended above, the generator local DGC-2020HD performs all primary protective functions. It will annunciate all of the alarms and pre-alarms it normally would in a non-redundant system. The remote DGC-2020HD provides a secondary set of protection. When either DGC-2020HD detects a pre-alarm condition, both DGC-2020HD units will annunciate a DGC SYSTEM pre-alarm along with any other pre-alarms that are in effect. Both units must be checked to see what other pre-alarms are in effect in addition to the DGC SYSTEM pre-alarm to determine what pre-alarm conditions led to the DGC SYSTEM pre-alarm annunciation.

Similarly, when either DGC-2020HD detects an alarm condition, both DGC-2020HD units will annunciate a DGC SYSTEM alarm along with any other alarms that are in effect. Both units must be checked to see what other alarms are in effect in addition to the DGC SYSTEM alarm to determine what alarm conditions led to the DGC SYSTEM alarm annunciation.

This implementation ensures any faults detected by the generator local DGC-2020HD or the remote DGC-2020HD will be seen by operating personnel.

Logic Configuration

The DGC-2020HD BESTlogicPlus Programmable Logic and Distributed Broadcast Logic can be used to achieve

redundant Off/Run/Auto control. Once implemented, pressing the Off button on either unit will place both units in Off mode; pressing the Auto button on either unit will place both units in Auto mode; and pressing the Run button on either unit will place both units in Run mode.

Auto/Off/Run Mode Control Logic

Distributed broadcast logic element 1 is used for system Off mode status, distributed broadcast logic element 2 is used for system Auto mode status, and distributed broadcast logic element 3 is used for system Run mode status.

Note

Distributed broadcast logic is used to implement the dual DGC-2020HD system. There cannot be any other DGC-2020HD units on the same network subnet that have distributed logic broadcast enabled or the Auto/Off/Run mode logic may not function correctly.

A local mode change request occurs when a front panel button is pressed. A remote mode change request occurs when the "Or" output of a distributed broadcast logic element is true, but the "And" output is not. When the "And" output is true, it indicates all units in the system are in the same mode. When a local or remote mode change is requested in the system, the logic holds the appropriate OFF MODE, RUN MODE, or AUTO MODE logic element until all machines in the system are in the same mode.

Off Mode Change Requests

Distributed broadcast logic element 1 is used for system Off mode status. When the "And" output is true, all units on the network are in Off mode. See Figure 1.

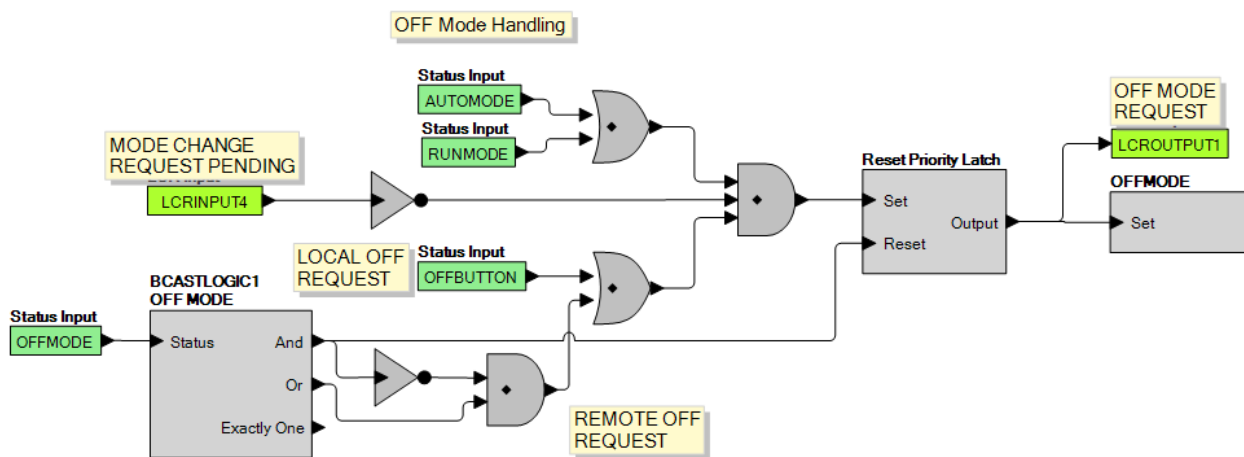

Figure 1

Run Mode Change Requests

Distributed broadcast logic element 3 is used for system Run mode status. When the “And” output is true, all units on the network are in Run mode. See Figure 2.

Auto Mode Change Requests

Distributed broadcast logic element 2 is used for system Auto mode status. When the “And” output is true, all units on the network are in Auto mode. See Figure 3.

Mode Change in Progress Detection

The logic in Figure 4 implements detection of Mode Change in Progress.

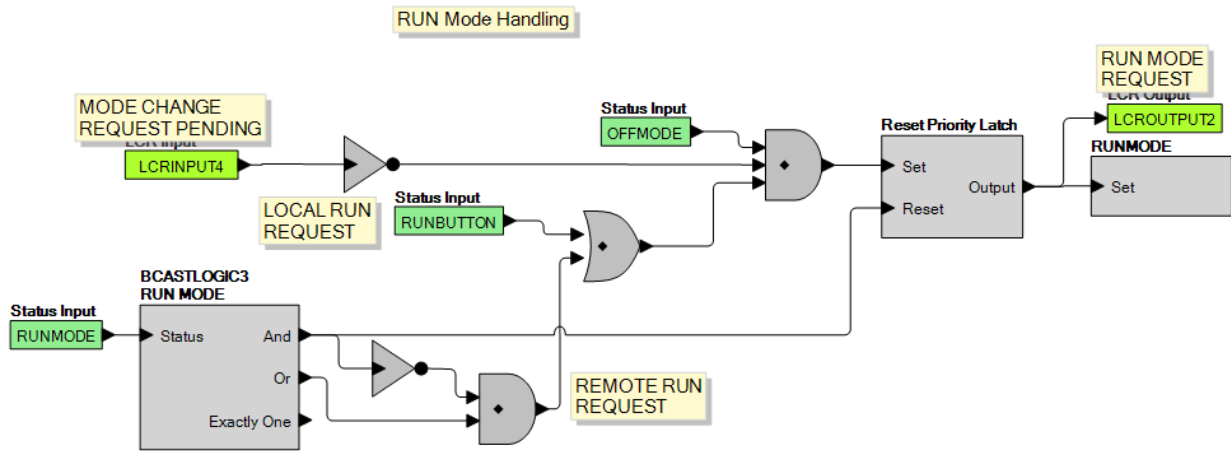

Figure 2

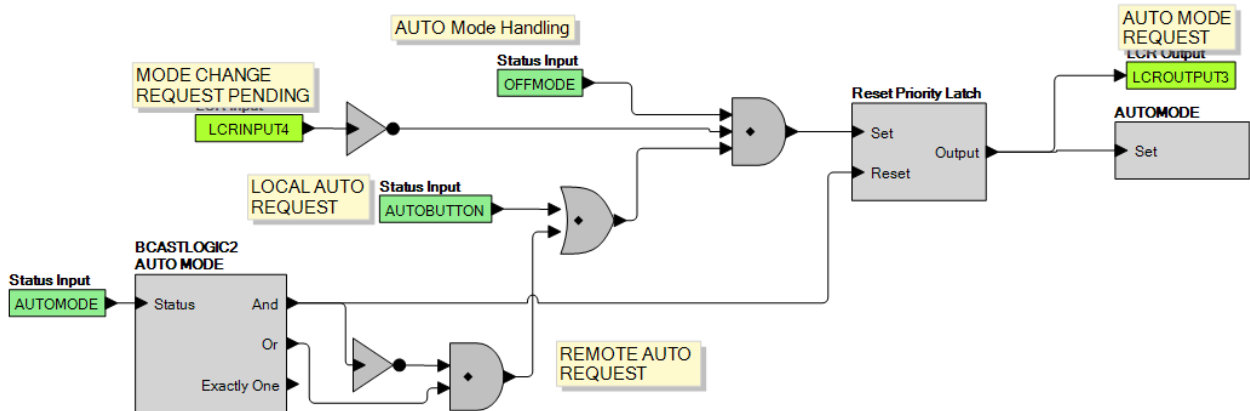

Figure 3

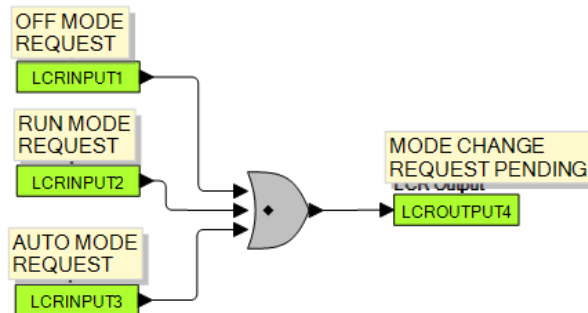

Figure 4

Alarm and Pre-Alarm Annunciation Logic

Distributed broadcast logic is used for system alarm and pre-alarm annunciation.

When either DGC-2020HD detects a pre-alarm condition, both DGC-2020HD units will annunciate a DGC SYSTEM pre-alarm along with any other pre-alarms that are in effect. Both units must be checked to see what other pre-alarms are in effect in addition to the DGC SYSTEM pre-alarm to determine what pre-alarm conditions led to the DGC SYSTEM pre-alarm annunciation.

Pressing the Reset button on either DGC-2020HD will clear the DGC SYSTEM pre-alarm. If other pre-alarms are still in effect on either DGC-2020HD unit, immediately a DGC SYSTEM pre-alarm will be annunciated again.

Similarly, when either DGC-2020HD detects an alarm condition, both DGC-2020HD units will annunciate a DGC SYSTEM alarm along with any other alarms that are in

effect. Both units must be checked to see what other alarms are in effect in addition to the DGC SYSTEM alarm to determine what alarm conditions led to the DGC SYSTEM alarm annunciation.

Pressing the Off button on either DGC-2020HD places both units into Off Mode and will clear the DGC SYSTEM alarm. If other alarm conditions are still in effect on either DGC-2020HD unit, immediately a DGC SYSTEM alarm will be annunciated again.

DGC-2020HD DGC SYSTEM Pre-Alarm Annunciation

The logic in Figure 5 should be implemented in both the generator local DGC-2020HD and the remote DGC-2020HD for DGC SYSTEM pre-alarm annunciation.

DGC-2020HD DGC SYSTEM Alarm Annunciation

The logic in Figure 6 should be implemented in both the generator local DGC-2020HD and the remote DGC-2020HD for DGC SYSTEM alarm annunciation.

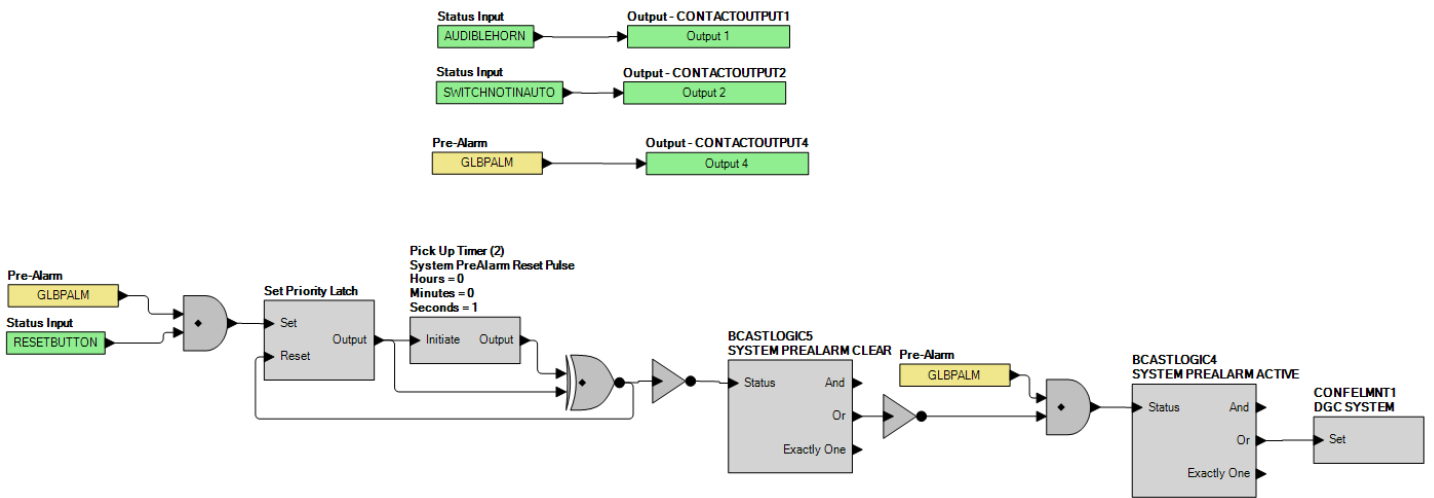

Figure 5

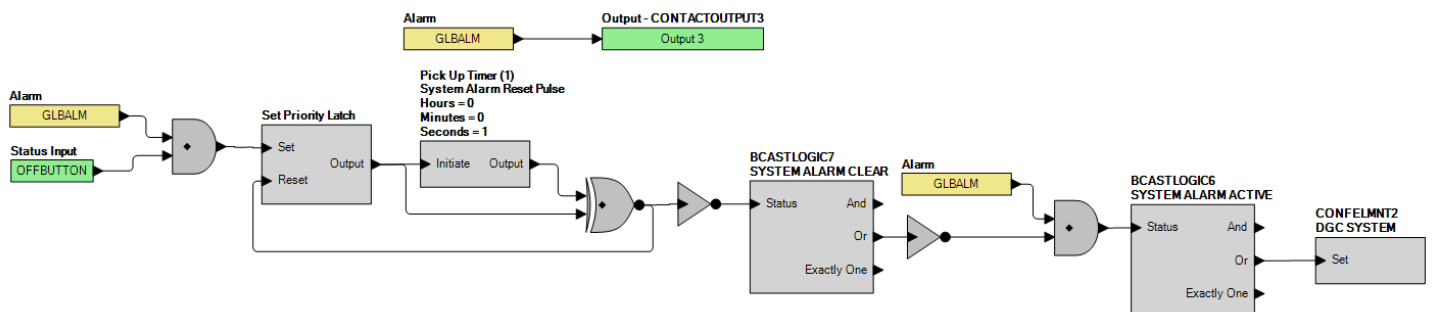

Figure 6

Distributed Broadcast Logic Configuration

The distributed broadcast logic configuration is the same for both the generator local DGC-2020HD and the remote DGC-2020HD. Figure 7 shows the distributed broadcast logic settings in BESTCOMSPiUs.

Distributed Logic Broadcast

Enable
 Disabled
 Enabled

Broadcast Logic

Broadcast Logic 1
OFF MODE

Broadcast Logic 2
AUTO MODE

Broadcast Logic 3
RUN MODE

Broadcast Logic 4
SYSTEM PREALARM ACTIVE

Broadcast Logic 5
SYSTEM PREALARM CLEAR

Broadcast Logic 6
SYSTEM ALARM ACTIVE

Broadcast Logic 7
SYSTEM ALARM CLEAR

Figure 7

Configurable Element Configuration

The configurable element configuration is the same for both the generator local DGC-2020HD and the remote DGC-2020HD. Figure 8 shows the configurable element settings in BESTCOMSPiUs.

Configurable Elements

Configurable Element #1

Alarm Configuration
Pre-Alarm

Activation Delay (s)
0

Label Text
DGC SYSTEM

Contact Recognition
Always

Configurable Element #2

Alarm Configuration
Alarm

Activation Delay (s)
0

Label Text
DGC SYSTEM

Contact Recognition
Always

Logic Timer Configuration

The logic timer configuration is the same for both the generator local DGC-2020HD and the remote DGC-2020HD. Figure 9 shows the logic timer settings in BESTCOMSPiUs.

Logic Timers (1-8)

**NOTE: Values on this screen are not sent to the device with Logic. These values must be sent using an Upload Settings method.

Logic Timer 1

Name
System Alarm Reset Pulse

Time Delay

Hours
0

Minutes
0

Seconds
1.0

Logic Timer 2

Name
System PreAlarm Reset Pulse

Time Delay

Hours
0

Minutes
0

Seconds
1.0

Figure 9

For more information

For questions or additional information including more application notes, product bulletins, instruction manuals, and technical papers, visit www.basler.com.