

Application Note

Demand Start/Stop Setup with the DGC-2020HD

Many paralleled, multiple-generator applications require a system to monitor load and optimize fuel efficiency while ensuring enough generating capacity is online for the expected load demand. The DGC-2020HD's Demand Start/Stop function automatically performs this optimization without the need for external devices.

The Demand Start/Stop function operates in one of two modes: Per Unit Load or Spinning Reserve. When Per Unit Load mode is selected, the DGC-2020HD issues start and stop requests based on per unitized system load. When Spinning Reserve mode is selected, the DGC-2020HD maintains a level of reserve capacity by starting an additional generator when necessary to ensure that reserve capacity is maintained.

The primary function of Demand Start/Stop is to provide start and stop request information to the sequencing handler. Generator sequencing must be enabled in order for Demand Start/Stop to function. If system load is above a set level and the corresponding start level timeout has been exceeded, a corresponding start request is issued. If system load is below the delayed stop level and the stop timeout has been exceeded, a stop request is issued.

The spinning reserve function is used in conjunction with generator sequencing to run the number of generators necessary to power the existing load plus provide an additional reserve power level.

For example, a power station normally has a 2,300 W load throughout the day, with an occasional 500 W power swing. Without spinning reserve, the DGC-2020HD starts only the number of generators needed to power the 2,300 W load. When the additional 500 W load is applied, another generator is started and when the additional load is removed, this same generator is shut down.

With a spinning reserve, the user can adjust a setting to account for the power swing. The reserve load is added to the actual load to find the adjusted load. This adjusted load is per-unitized to determine whether a generator

needs to be started or stopped. To prevent constant starting and stopping, a hysteresis setting is also provided. There are two reserve levels: one for normal operation, and a second to start a unit more quickly when there is less reserve.

The BESTCOMSPi[®] Demand Start/Stop screen is illustrated in Figure 1.

NOTE

Each DGC-2020HD must have a unique IP address set and should be connected to a properly configured Ethernet switch. If only two units are used in a system with copper Ethernet connections, a standard Ethernet cable with RJ-45 jacks can be used to connect the units without a switch.

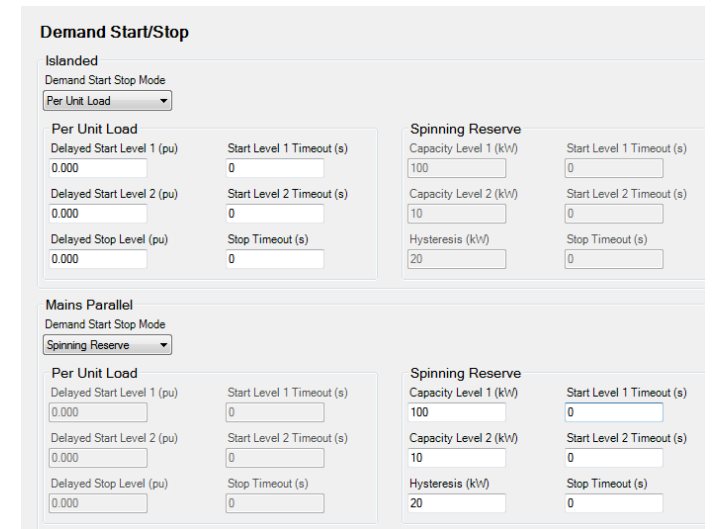

Figure 1

Demand Start/Stop Configuration Example

The demand Start/Stop function works in conjunction with generator sequencing. The following is an example of how to configure the Demand Start/Stop function.

Ensure that all participating generators are set for Multiple Generator or Segmented Bus System under System Parameters, System Settings in BESTCOMSPi as shown in Figure 2.

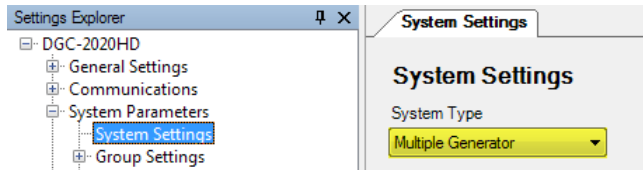

Figure 2

CAUTION

The Load Control Enable setting must be enabled for generator sequencing to function properly. This setting is found on the Governor Bias Control Settings screen in BESTCOMSPi.us or through the front-panel interface.

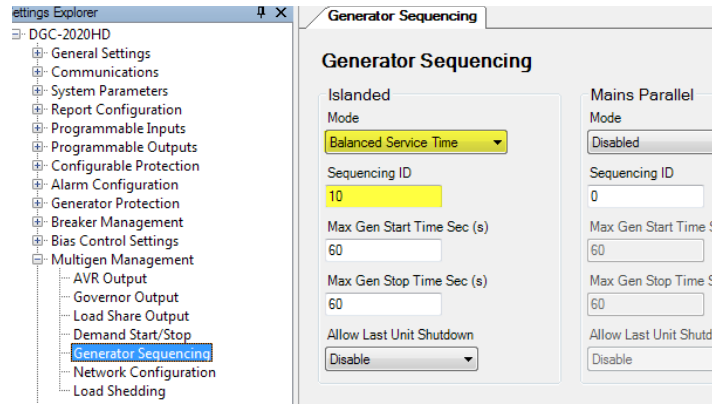

Figure 3

Configure the following parameters on the Generator Sequencing screen in BESTCOMSPi.us. See Figure 3.

- Mode** - Select the desired generator-sequencing mode. Selections include Disabled, Staggered Service Time, Balanced Service Time, Largest Size First, Smallest Size First, Smallest Unit ID First, and Adopt System Mode. When disabled, the unit does not participate in sequencing. When any mode other than Disabled or Adopt System Mode is selected, all machines on the intergenset communications network switch to the newly programmed mode. If generator sequencing is being configured before an intergenset communications network is in place, set all machines to the same mode. If a machine is added to the intergenset communications network and Adopt System Mode is selected, the machine's sequencing mode switches to the same mode as the other machines on the network.
- Sequence ID** - Enter a value for the sequence ID. The ID must be a unique, nonzero value for each machine participating in generator sequencing. Assigning a unique ID for each machine is recommended. Machines with a sequence ID of zero do not participate in generator sequencing. In addition, machines with a sequence ID of zero are not considered when checking for ID Missing and ID Repeat pre-alarms on the network. The Sequence ID setting is discussed in further detail under Network Configuration.
- Max Gen Start Time (s)** - This setting defines the maximum time in seconds that generator sequencing waits for a machine to start. If a successful start does not occur before the Max Gen Start Time expires, generator sequencing attempts to start the next machine on the priority list. Set the Max Gen Start Time to allow enough time for a normal start and generator-loading ramp to occur. If set too short, an additional generator may start.
- Max Gen Stop Time (s)** - This setting defines the maximum time in seconds that generator sequencing waits for a machine to stop. If a successful stop does not occur before the Max Gen Stop Time expires, generator sequencing attempts to stop the next machine on the priority list. Set to allow sufficient time for a normal generator unload and stop to occur.
- Allow Last Unit Shutdown** - Enabling this setting allows the last unit to shut down if there is no load on the system.

In DGC-2020HD units containing firmware version x.03.00 or higher, Balanced Engine Hours can be selected as shown in Figure 4. In generators with an Engine Control Unit (ECU) employing CANbus communications, this mode is based on the engine hours broadcast over the CANbus

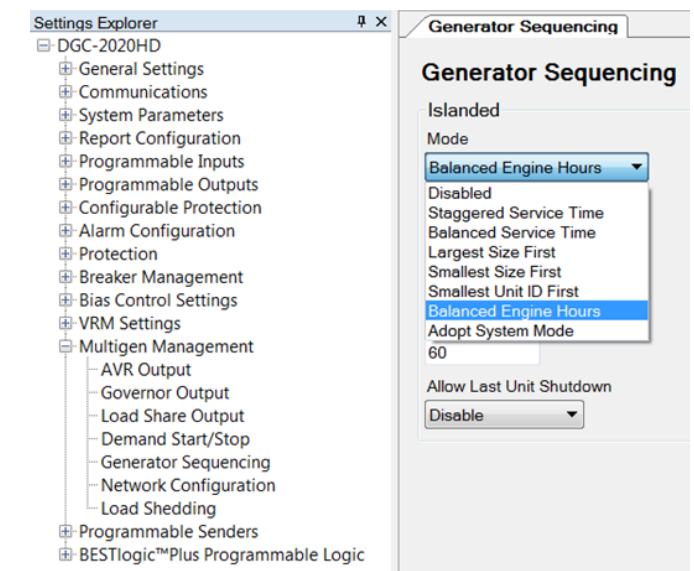

Figure 4

interface. In this example, the mode is set to Balanced Service Time which monitors the time remaining before the Maintenance Interval pre-alarm is annunciated, indicating that service is required. The maximum setting is 5,000 hours.

Network Configuration

Set the Expected Sequence ID (1 to 255) for each unit starting with Expected Sequence ID 1. See Figure 5. This value must be a unique number for each unit on the intergenset communications network.

Setting the Expected Sequence IDs allows the DGC-2020HD to annunciate a pre-alarm if a machine is missing (ID Missing pre-alarm) or if an ID is repeated (ID Repeat pre-alarm) on the network. These pre-alarms help diagnose problems on the intergenset communications network. If annunciation of these pre-alarms is not desired, set all expected sequence IDs to zero. To block the pre-alarms for a particular machine when it is offline, set its Expected Sequence ID to zero.

It is likely that these pre-alarms will announce on multiple machines at the same time. For instance, if a communication cable is disconnected from one of the units, all other units on the network will announce ID Missing pre-alarms. In addition, the unit with the disconnected cable will announce the pre-alarm because it does not see the IDs of the other machines on the network.

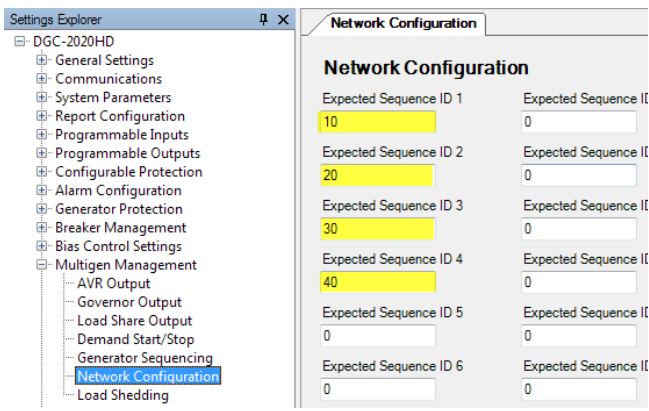

Figure 5

Demand Start/Stop Settings

The DGC-2020HD has settings for two demand start levels and two timeouts. Dual settings allow the user to set up a lower system power level with a long timeout for normal generator starts. But, if the system power level exceeds a higher level for a shorter time, machines can be brought online quickly. This type of situation may occur when a machine is shut down due to an alarm and an additional machine must be brought online quickly to replace the lost generation capacity.

Configure the following parameters on the Demand Start/Stop screen in BESTCOMSPi.us. See Figure 6.

- Demand Start/Stop Enable - Select Per Unit Load to enable the Demand Start/Stop function.
- Delayed Start Level 1 (PU) - This setting defines the level (in Per Unit) at which the sequence for starting another machine should occur. After the Start Level 1 Timeout expires, another machine is started.
- Start Level 1 Timeout - This setting defines the delay before starting a machine when the system per unit power level has exceeded Delayed Start Level 1.
- Delayed Start Level 2 (PU) - This setting defines the level (in Per Unit) at which the sequence for starting another machine should occur. After the Start Level 2 Timeout expires, another machine is started.
- Start Level 2 Timeout - This setting defines the delay before starting a machine when the system per unit power level has exceeded Delayed Start Level 2.
- Delayed Stop Level (PU) - This setting defines the level (in Per Unit) at which the sequence for stopping another machine should occur. After the Stop Level Timeout expires, another machine is shut down.

- Stop Timeout - This setting defines the delay before stopping a machine when the system per unit power level is below the Delayed Stop Level.

In the example below, the Delayed Start Level 1 (PU) is set to 0.800 for 80% of the system-rated capacity. The Start Level 1 Timeout is set to 15 seconds, which causes the next unit to start and parallel to the bus.

However, if the system average load reaches the Delayed Start Level 2 for the duration of the Start Level 2 Timeout (5 s), the next sequenced unit is started. This allows another unit to be started quickly if the first unit fails to start, shuts down due to a fault, or is insufficient to cover a large load change.

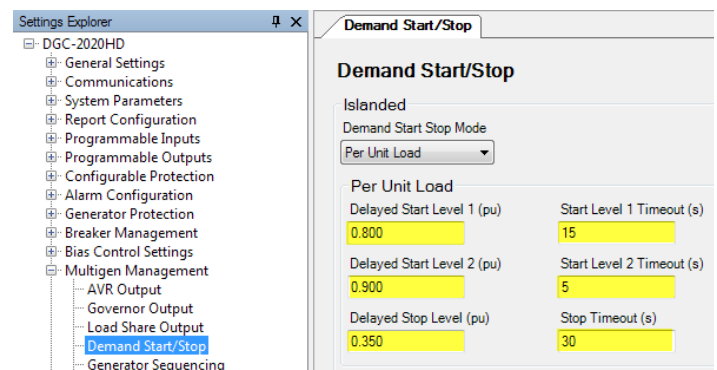

Figure 6

Spinning Reserve

Configure the following parameters on the Demand Start/Stop screen in BESTCOMSPi.us. See Figure 7.

- Demand Start/Stop Mode - Select Spinning Reserve to enable the Demand Start/Stop function.
- Capacity Level 1 (kW) - This setting defines the level (in reserve kW) at which the sequence for starting another machine should occur. After the Start Level 1 Timeout expires, another machine is started.
- Start Level 1 Timeout - This setting defines the delay before starting a machine when the system reserve kW capacity level is below Capacity Level 1.
- Capacity Level 2 (kW) - This setting defines the level (in reserve kW) at which the sequence for starting another machine should occur. After the Start Level 2 Timeout expires, another machine is started.
- Start Level 2 Timeout - This setting defines the desired delay before starting a machine when the system reserve kW capacity level is below Delayed Start Level 2.
- Hysteresis (kW) - This setting prevents constant starting and stopping.
- Stop Level Timeout - This setting defines the delay before stopping a machine when the system reserve kW level is above the maximum of Capacity Level 1 and Capacity Level 2, plus the Hysteresis. The system determines if stopping a machine will lower reserve to a level that would result in a machine starting. A machine will not be stopped unless it is determined that there is sufficient reserve in the system after the machine is removed.

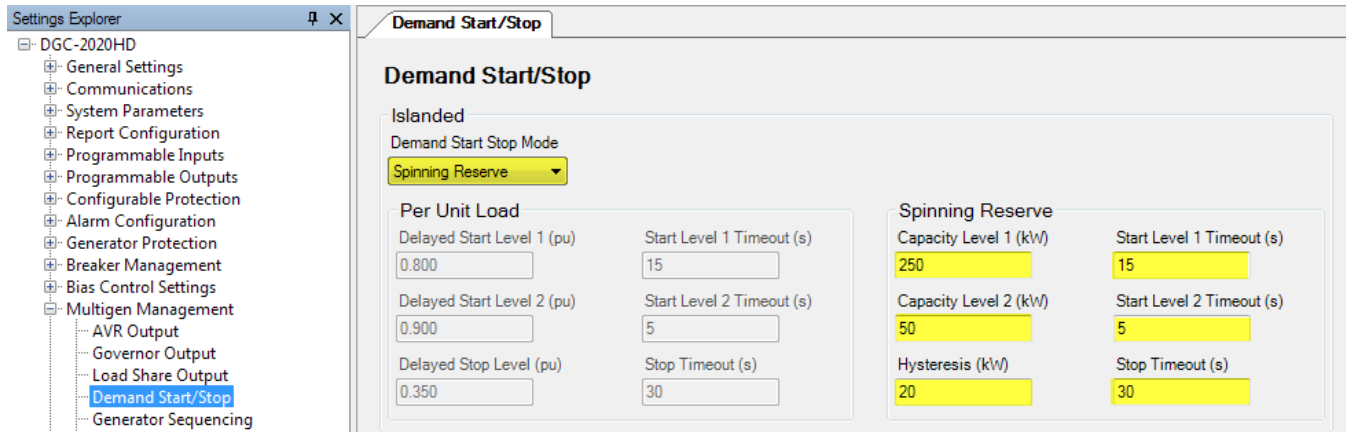

Figure 7

Spinning Reserve vs Per Unit Load

In Per Unit Load configuration, the next unit starts based on Equation 1 for the duration of the Start Level Timeout. The next unit stops based on Equation 2 for the duration of the Stop Timeout.

$$P_{avg,sys,PU} > StartLevel$$

Equation 1

$$P_{avg,sysPU} < StopLevel$$

Equation 2

- $P_{avg,sys,PU}$ = the per unit generation average of all machines on the system

In Spinning Reserve configuration, the next unit starts based on Equation 3 for the duration of the Start Level Timeout. The next unit stops based on Equation 4 for the duration of the Stop Timeout.

$$(P_{rated,sys} - P_{tot,sys}) < CapacityLevel$$

Equation 3

$$(P_{rated,sys} - P_{tot,sys} - P_{rated,nextToStop}) > (Hysteresis + \max\{Capacity1, Capacity2\})$$

Equation 4

- $P_{rated,sys}$ = the sum of all rated kW values of all machines on the system
- $P_{tot,sys}$ = the total generated kW of all machines on the system
- $P_{rated,nextToStop}$ = the rated kW of the next unit to stop based on sequencing order

The hysteresis value guarantees enough kW of reserve capacity between the time a unit stops and another unit is started.

In a system with many machines or machines of varying rated capacity, it may be easier to configure spinning reserve sequencing than per-unit based sequencing, because all values are specified directly in kW.

It is often easier to configure systems with three or more generators using spinning reserve rather than per-unit based sequencing.

Example

Four units (100 kW each) have their Delayed Start Level 1 set to 0.800 or 80 kW to start the next unit. After the next unit starts, the load becomes 40% on each unit. Therefore, the Stop Level should be set below 40% (approximately 0.350). If the load is slowly increased to 250 kW, all four units go online. In order to stop the first unit when load decreases, the load must fall below 140 kW (Delayed Stop Level 0.350) to stop the next unit. The other three units remain running at loads above 105 kW.

However, if the spinning reserve is set to 20 kW, equal to the 80% Start Level, four units would not be online at 250 kW load. The second unit would start at 80 kW load, the third unit would start at 180 kW load, and the fourth unit would start at 280 kW load. If the hysteresis is set to 10 kW, there would be 30 kW of reserve when a unit stops. The fourth unit would stop after the load decreased below 270 kW. At this point, there is 30 kW of system reserve capacity (300 kW rated – 270 kW load). There is 10 kW of hysteresis before the fourth unit would start again. If the load continues to decrease, the third unit would stop at 170 kW load. The second unit would stop at 70 kW load and only the first unit would remain running. The values in this example demonstrate how it is easier to coordinate start and stop levels using Spinning Reserve mode.

Interoperability of the Run with Load Logic Element and the Demand Start/Stop Function

The Run with Load logic element and the Demand Start/Stop function can be used together; they are not independent of each other. The system can be started or stopped by either the Run with Load logic element or the Demand Start/Stop function. Since they share

functionality, one function can stop the system even if the other one started it. Thus, if a machine was started by pulsing the Start input of the Run with Load logic element, it could be stopped by the Demand Start/Stop function. This can be useful in a scenario when it may be desired to start a number of generators at the same time, but sequence some of them off if the load does not require them. The Start input of the Run with Load logic element could be pulsed on all units, causing them to start and close their breakers. Then, the Demand Start/Stop function and Sequencing could cycle them on and off as load requirements change.

In order for the Run with Load logic element and Sequencing to operate reliably, it is recommended that the inputs to the Run with Load logic element be pulsed rather than held constant. For example, if a unit was started by Sequencing, a pulse on the Stop input of the Run with Load logic element would shut down the unit. However, if the Stop input is held constant, Sequencing can never start a

unit because the sequencing starts would be immediately negated by pulsing the Stop input of the Run with Load logic element. Similarly, if the Start input of the Run with Load logic element is pulsed held constant, sequencing cannot shut down the unit. Any stops generated by sequencing would immediately be negated by pulsing the Start input of the Run with Load logic element.

NOTE

If the Automatic Transfer Switch (ATS) function is used to start a unit, that unit will not participate in sequencing. In sequenced systems, it is recommended that the ATS Input under Programmable Inputs, Programmable Functions in BESTCOMSPPlus is set to None in order for the Demand Start/Stop function to work properly. The ATS input should be designated as the Remote Start input in BESTlogic™Plus.

In a system with per-unit based sequencing, if the last unit online shuts down on a fault, there is no load on the system. This causes all units to remain offline. The logic shown in figures 8 and 9 allows the Run with Load element to be re-pulsed by the Configurable Protection element set as Number of Units Online.

For more information

For assistance with product orders, questions about the DGC-2020HD, information on BESTCOMSPPlus software, more application notes, product bulletins, and instruction manuals, go to www.basler.com, contact your Application Engineer, or contact Technical Support at +1 618.654.2341.

Configurable Protection #1

Label Text # units online	Operator None	Arming Delay (s) 0
Parameter 1 Parameter Selection Number of units online	Parameter 2 Parameter Selection No Parameter Selected	Hysteresis (%) 2.0
Scale Factor 1.00	Scale Factor 1.00	Alternate Frequency Scale Factor 1.000
Offset 0.00	Offset 0.00	Voltage Low Line Scale Factor 1.000
		Current Low Line Scale Factor 1.000
Threshold #1		
Mode Under	Threshold 0.50	Activation Delay (s) 0
		Alarm Configuration Status Only

Figure 8

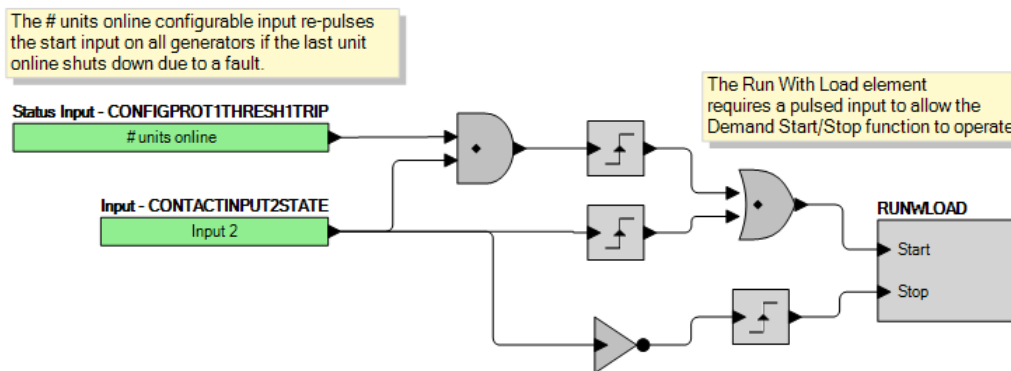

Figure 9

The logo features a stylized blue "B" followed by the text "Basler Electric" in a blue sans-serif font.

Highland, Illinois USA
Tel +1 618.654.2341
Fax +1 618.654.2351
email: info@basler.com

Suzhou, P.R. China
Tel +86 512.8227.2888
Fax +86 512.8227.2887
email: chinainfo@basler.com

