

# Application Note

## DGC-2020HD Broadcast Logic – Generator Group Breaker Control Examples

### The DGC-2020HD Digital Genset Controller has 128 broadcast logic elements available in the BESTlogic™Plus Programmable Logic functionality.

The status of each element is broadcast to every other DGC-2020HD in a system and the state of each element can be used in the PLC Logic of any or all DGC-2020HD controllers in the system. This application note presents an overview of the setup and application of the DGC-2020HD broadcast logic elements.

### Using Broadcast Logic Elements

Broadcast logic elements are enabled and configured on a settings tab in BESTCOMSPPlus®. In the Settings Explorer, the navigation path is: BESTlogicPlus Programmable Logic, Distributed Logic Broadcast. First, enable broadcast logic, then assign user-programmable labels as needed. Each label has a limit of 64 characters. Figure 1 illustrates the Distributed Logic Broadcast tab and its navigation path in the BESTCOMSPPlus Settings Explorer.

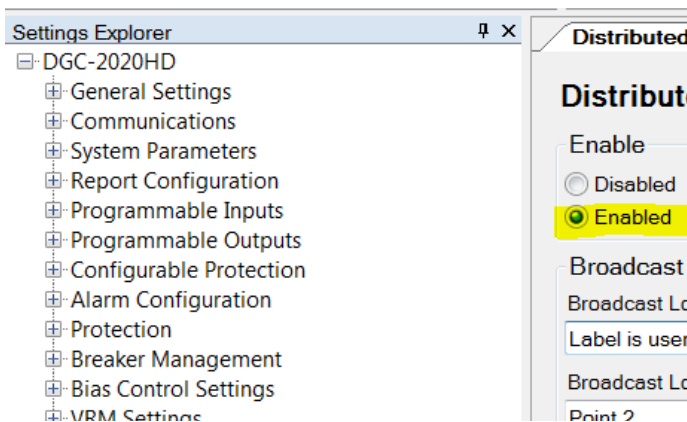

Figure 1. Distributed Logic Broadcast Tab

A broadcast logic block is illustrated in Figure 2 and has the following elements:

- Status input is driven individually by each DGC-2020HD controller. The Status input of every element of each controller is broadcast over the communication network.

- And element provides a logical AND output of all status inputs from every controller. This output is true when the Status input of all controllers is true.
- Or element provides a logical OR output of all status inputs from every controller. This output is true when the Status input of any controller is true.
- Exactly One element provides a logical XOR output of all status inputs from every controller. This output is true when the Status input of only one controller is true.

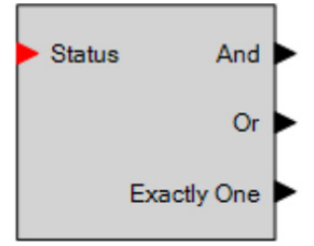

Figure 2. Broadcast Logic Block

A logic block is applied by dragging it from the list of broadcast logic elements and dropping it on a logic page. Figure 3 illustrates a logic block dragged from the logic library onto a logic page.

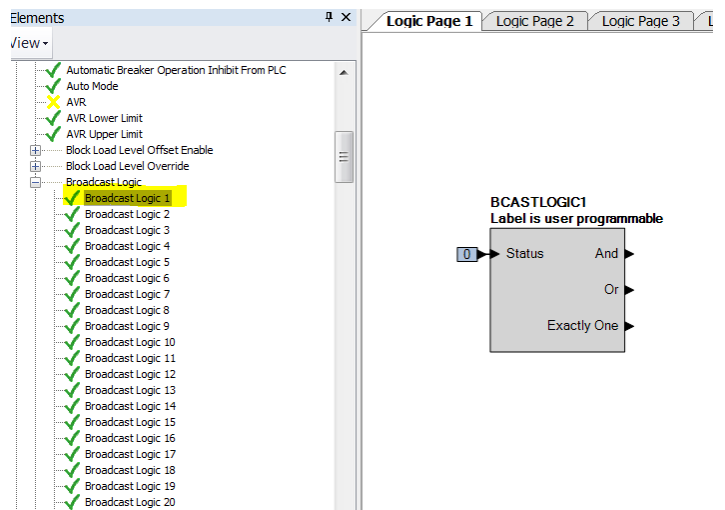

Figure 3. Broadcast Logic Block Dragging and Dropping

The status of broadcast logic elements is readily available in the Metering Explorer of BESTCOMSPPlus.

Figure 4 illustrates a BESTCOMSPPlus metering screen showing the status of the broadcast logic elements.

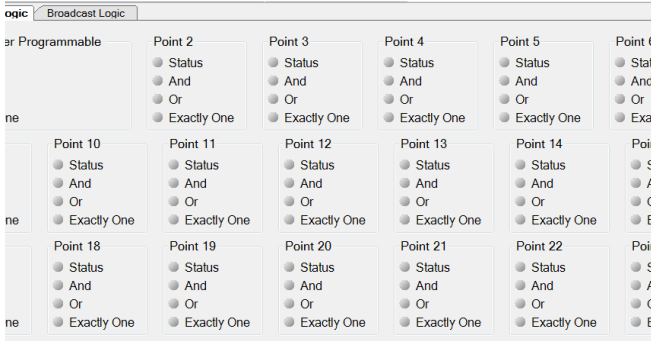

Figure 4. Status of Broadcast Logic Elements

Figure 5 illustrates a BESTCOMSPPlus metering screen showing the system-wide broadcast logic points for every DGC-2020HD in the network.

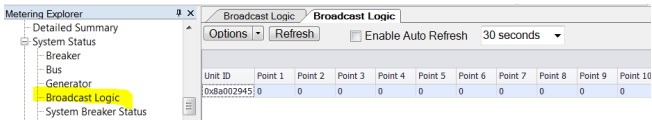

Figure 5. System-Wide Broadcast Logic Points

### Application Examples

The following examples illustrate how DGC-2020HD broadcast logic elements can be applied within simple logic schemes to provide distributed, system-wide control functionality.

#### Example 1

The system illustrated in Figure 6 has four generators that operate in parallel on a common bus. A tie breaker acts as a generator group breaker between the generator bus and the load.

Each generator is controlled by a DGC-2020HD set up with a System Breaker Configuration of Generator Breaker Control (Figure 7).

A DGC-2020HD controller also monitors and controls the generator group breaker. This controller is set up with a System Breaker Configuration of Tie Breaker Controller (Figure 8).

We want each generator to broadcast its generator breaker status and we want the generator group breaker to close when all generators indicate that their generator breaker is closed. We can use the broadcast logic elements to create simple logic to meet these functional requirements.

In the DGC-2020HD for each generator, create logic that drives the Broadcast Logic 1 element with the generator breaker status. See Figure 9.

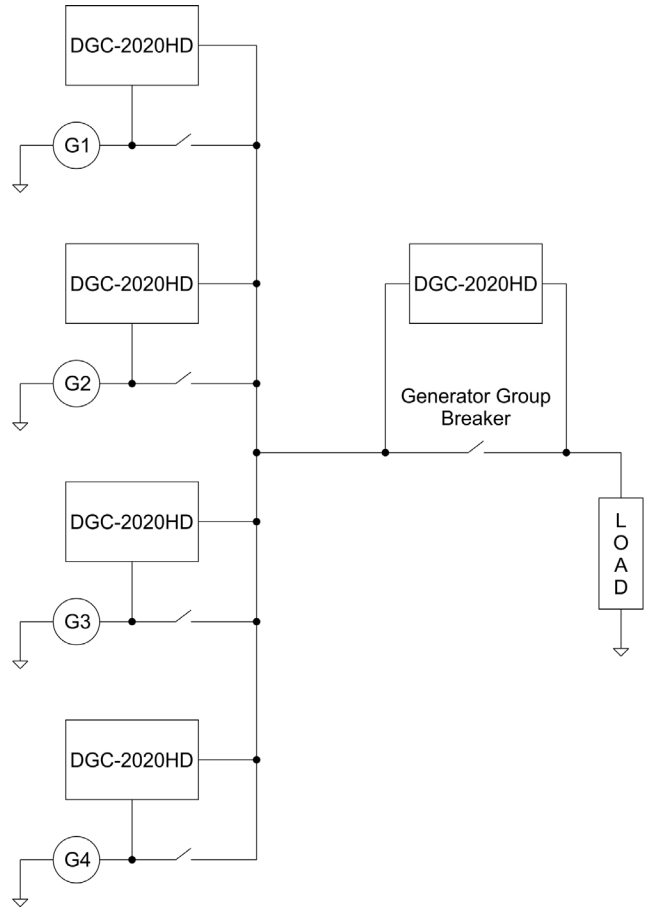

Figure 6. Example System

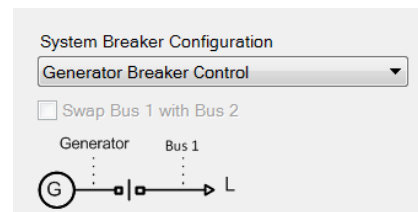

Figure 7. Individual Generator Breaker Configuration

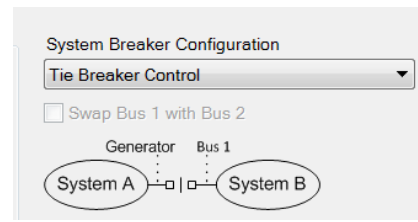

Figure 8. Generator Group Breaker Configuration

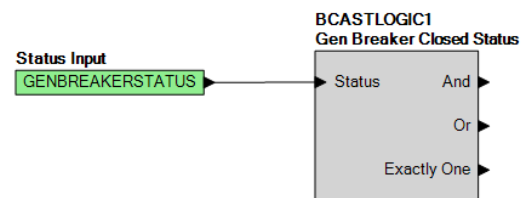

Figure 9. Broadcast Logic 1 Element Driven by the Generator Breaker Status

In the DGC-2020HD controlling the generator group breaker, use the AND output of the Broadcast Logic 1 element to drive the breaker close request on the tie breaker logic block. The AND output of the Broadcast Logic element is true when all devices that drive the element are true. In this system, that means all generators have their generator breakers closed because each generator's DGC-2020HD is driving the Broadcast Logic 1 element with its Generator Breaker Status. This logic is illustrated in Figure 10.

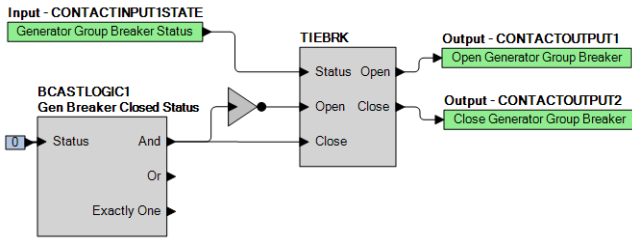

Figure 10. Generator Group Breaker Logic

Now suppose we want each DGC-2020HD to light one of its programmable front-panel LEDs if the generator bus is energized. One method for providing this functionality is to drive the output if any generator has closed its generator breaker to the generator bus. We could use the OR output from the Broadcast Logic 1 element to achieve the desired operation. The logic shown in Figure 11 sets Programmable LED 1 as the indicator for a live generator bus.

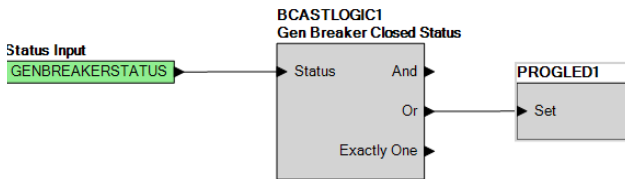

Figure 11. Generator Breaker Annunciation Logic

The annunciation logic for the generator group breaker is shown in Figure 12.

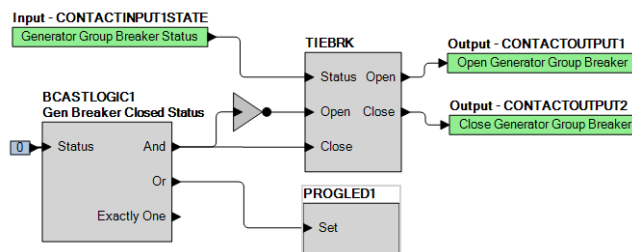

Figure 12. Generator Group Breaker Annunciation Logic

The system design is complete, illustrating how broadcast logic elements allow construction of complex system-wide control functionality with simple logic schemes in BESTlogicPlus.

### Example 2

Assuming the same system we had in Example 1, suppose it is decided that any three generators can adequately drive the load. So, it is desired to close the generator group breaker after any three generators are online. This enables system operation even if one generator is out of service or fails to start. We still wish to use Programmable LED 1 as an indication that the generator bus is live. Distributed logic will be used in a similar manner as in Example 1 but now each generator will drive a different broadcast logic element with its generator breaker status. Generator 1 will drive the Broadcast Logic 1 element, generator 2 will drive the Broadcast Logic 2 element, and so on. The logic for the four generators is shown in Figure 13.

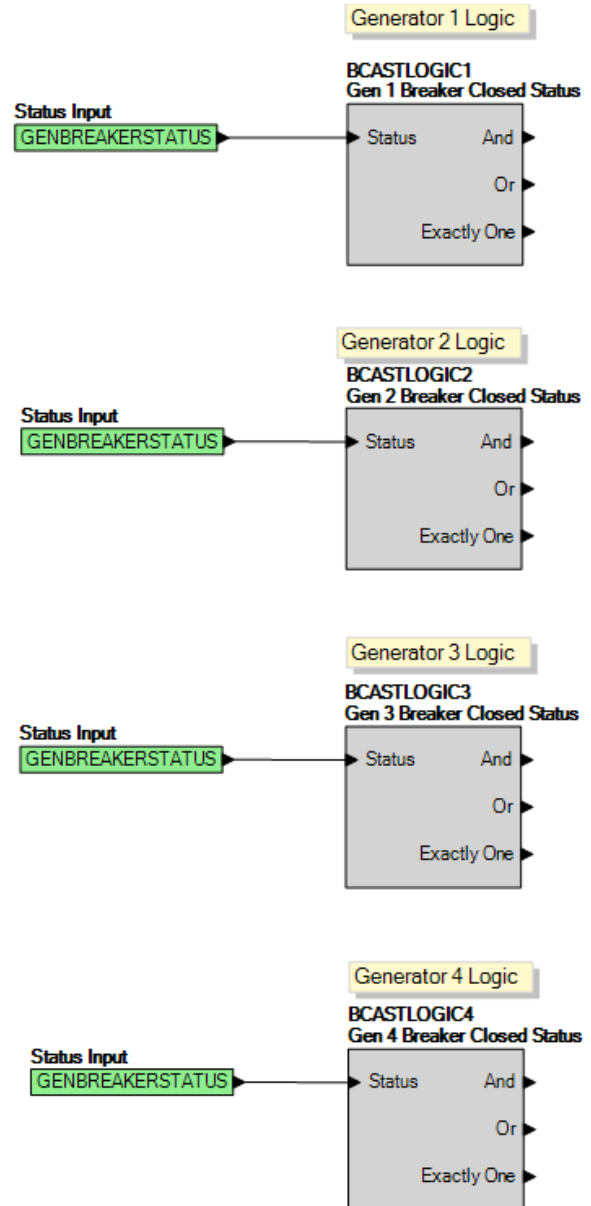

Figure 13. Example 2 Generator Breaker Status Logic

The logic in the generator group breaker DGC-2020HD is somewhat different than in Example 1. We use a Logic Input Counter element to determine when three or more generators are online, and to indicate when at least one generator is online. This logic will drive Programmable LED 1 to indicate the generator bus is live.

First, the logic input counters are configured. We will set conditions so that:

- Output 1 becomes true when three or more inputs are in the on state; and
- Output 2 becomes true when one or more inputs is true.

The Logic Input Counter settings are shown in Figure 14.

Now we can use the Logic Input Counter to set output 1 when three or more inputs are true and set input 2 when one or more inputs is true. Output 1 will issue a Tie Breaker Close request and output 2 will drive Programmable LED 1 to indicate the generator bus is live. This logic is shown in Figure 15.

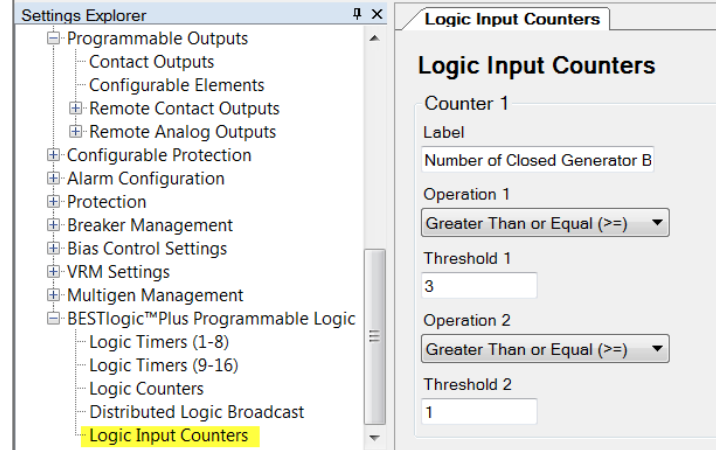

Figure 14. Logic Input Counter Settings

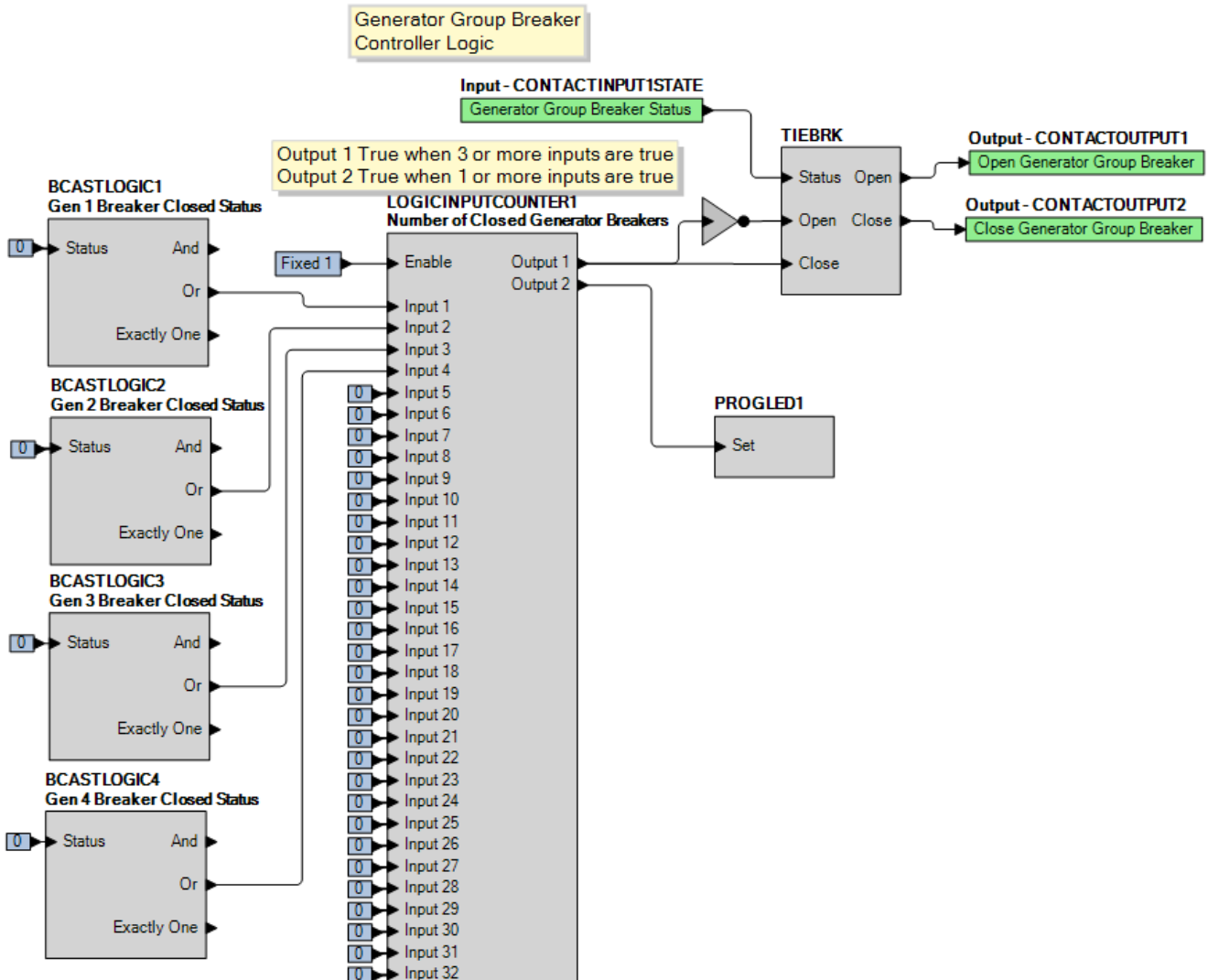

Figure 15. Generator Goup Breaker Controller Logic

In the DGC-2020HD on each generator, we will also use a logic input counter to drive a programmable LED to indicate the generator bus is live. The logic input counter conditions are set so that output 1 becomes true when one or more inputs is true, to indicate at the generator breaker on at least one generator is closed. The logic is shown in Figure 16.

This example illustrates another way that broadcast logic elements are a powerful tool to design complex, distributed system-wide control functionality with simple logic schemes in BESTlogicPlus.

### For More Information

To get more information on BESTCOMSPiUs and the DGC-2020 product line, including additional application notes, product bulletins and instruction manuals, go to [www.basler.com](http://www.basler.com) or contact Technical Support at +1 618.654.2341.

Programmable LED 1 turns on when any Generator Breaker is closed.

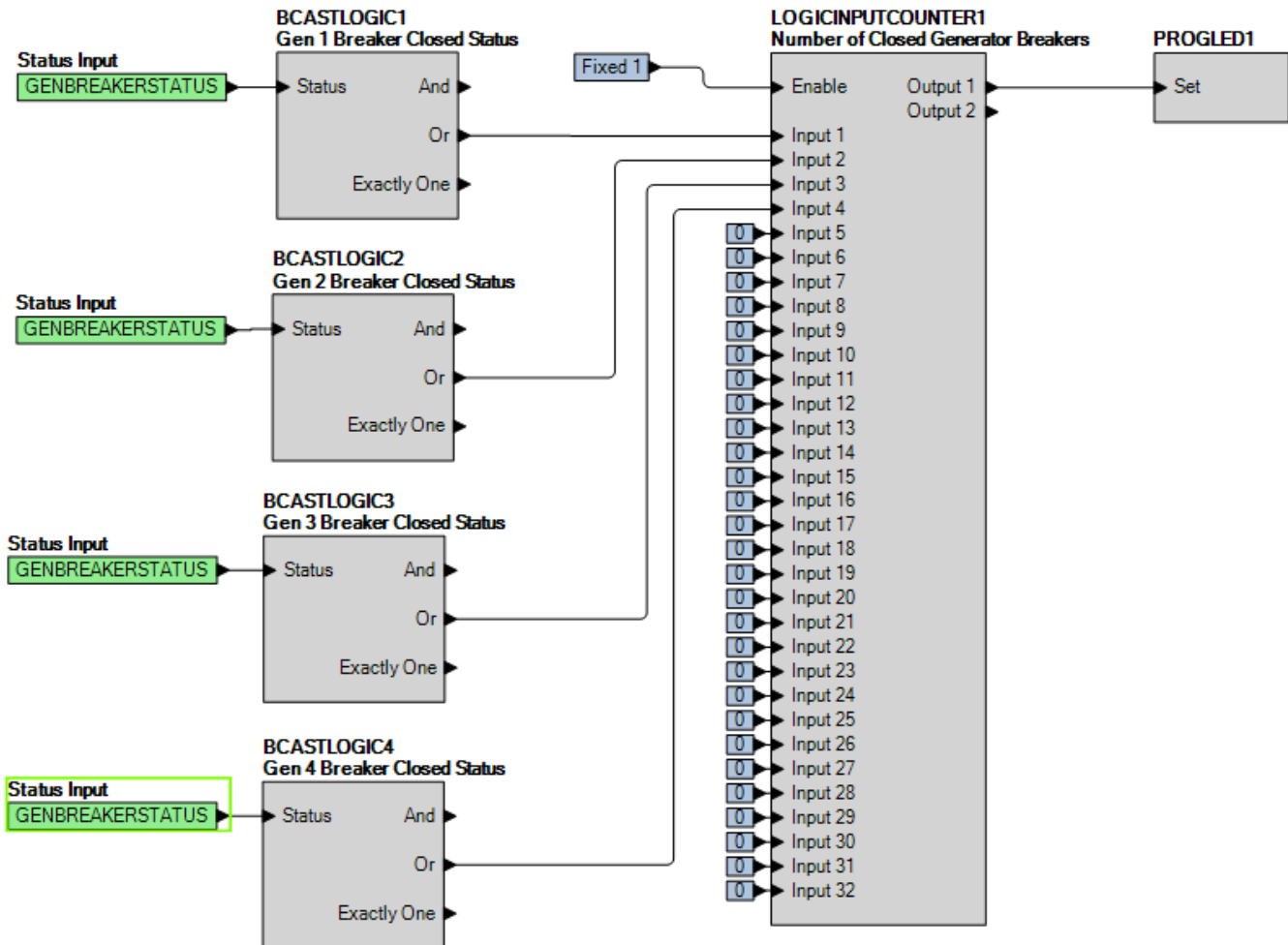

Figure 16. Live Generator Bus Indication Logic