

# Application Note

## DECS-2100 Bridge Redundancy and Paralleling

**The DECS-2100 Digital Excitation Control System (Figure 1) is Basler Electric’s most flexible control system and is used on generators with field current ratings up to 10,000 Adc.** Key DECS-2100 components include the ECM-2 Excitation Control Module, dc power rectifier bridge (power drawer), and BCM-2 Bridge Control Module. The ECM-2 system controller is offered in three fully independent configurations: single channel, redundant channel, or redundant with supervisory channel. Control channel redundancy increases reliability in the unlikely event of signals failing to reach a single controller or single controller failure. The DECS-2100 power drawer consists of a six-SCR (silicon-controlled rectifier) power rectifier bridge which provides the necessary excitation current to the generator. Each power drawer has a field current rating of 1,100 Adc and multiple power drawers may be placed in parallel.

Parallel bridges are common and are used to:

- Meet higher field current requirements
- Achieve redundancy (N+1, N+2)



Figure 1. DECS-2100 Digital Excitation Control System

### Forms of bridge redundancy

Two common forms of bridge redundancy are hot swap and N+1 or N+2 as stated in IEEE 421.4-2014, section 4.8.3.

In a hot swap configuration (Figure 2), both bridges are in parallel but only one rectifier bridge is in operation and provides all of the field current that is required for the system. If the primary bridge fails, the firing commands are transferred from the primary bridge to the secondary

bridge. This places the secondary bridge in operation while removing the primary bridge from service. Due to the transition time from the primary to the secondary bridge, a transient event may occur.

An N+1 or N+2 configuration (Figure 3) has all bridges in operation along with one or more additional bridges. The additional bridge or bridges share the load of the other rectifier bridges. In the N+1 configuration for example, if one bridge fails in a three-bridge system, the other two bridges are able to immediately pick up the field current that was being provided by the failed bridge, therefore, reducing the chance of causing a disturbance on the generator field. This would occur without any bridge transfer or taking the system offline for repair. In the DECS-2100, the power drawers can be taken offline and removed for maintenance while the DECS-2100 provides field current to the system.

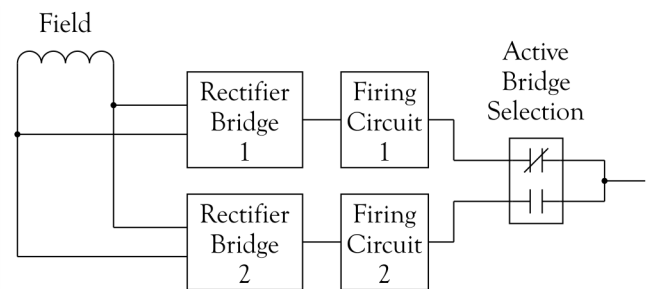

Figure 2. Hot Swap Bridge Redundancy

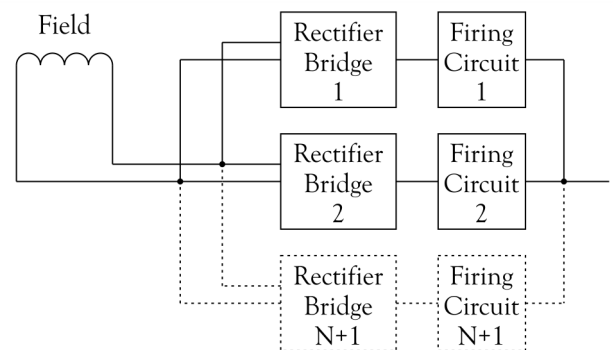

Figure 3. N+1 Bridge Redundancy

## Proper balance

In the DECS-2100, all paralleled rectifier bridges are in operation, such as in the N+1 or N+2 configuration, all SCRs fire at the same time in order to carry the necessary current. Because high temperature affects the life of an SCR, a proper balancing method is necessary to maintain safe SCR temperature. Two electronic methods are available to achieve rectifier bridge sharing: Active Current Balance (ACB) and Active Temperature Balance (ATB). Both of these methods use a feature known as skip firing, a technology patented by Basler Electric.

ACB uses an algorithm that regulates the average current of all the rectifier bridges in parallel by selectively controlling the firing pulses to each SCR. If an SCR is carrying current higher than the average, firing pulses to that SCR are skipped more often to reduce the current it carries. The result is balanced current on all SCRs, but the individual SCR temperatures may vary dramatically.

Unlike ACB, ATB monitors the temperature of each SCR using a resistance temperature detector (RTD). If an SCR's temperature is higher than average, its firing pulses are skipped more often to reduce the temperature. If an SCR's temperature is lower than average, its firing pulses are skipped less frequently which increases its temperature. The result is a safe, balanced temperature on all SCRs. Because this method does not affect the amount of field current being provided, the total amount of current from the SCRs remains at the full load desired and results in an average temperature on all SCRs (Figure 4). This approach maintains a more consistent temperature of each SCR to extend component life.

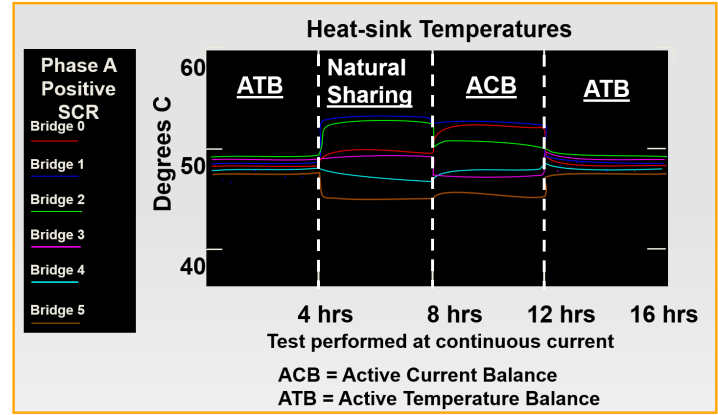

Figure 4. DECS-2100 Skip Firing maintains an average temperature on all SCRs.

Skip firing can be observed on the front panel of the BCM-2. LEDs for each SCR flash at the rate the corresponding SCRs are firing. An SCR with a higher temperature results in less frequent firing and an LED which flashes more slowly. An SCR with a lower temperature results in more frequent firing and an LED which flashes more quickly.

In conclusion, there are various forms of bridge redundancy and load balancing. Any form of bridge redundancy can protect a generator system from tripping at a critical time of needed generation. The better the paralleling in a system, the more reliable your system is with reduced risk of tripping offline.

## For more information

For further assistance with product orders or questions, contact Basler Electric Technical Support at 618.654.2341. For additional information on DECS-2100 systems, including more application notes and product bulletins, visit [www.basler.com](http://www.basler.com), contact your Application Engineer, or contact Technical Support at 618.654.2341.