INSTRUCTIONS

Basler Electric
Phone: +1 618.654.2341
Route 143, Box 269
Highland IL 62249 USA

FOR
SYNCHRONOUS MOTOR PULLOUT RELAY
PRP 320, PRP 340

Power Systems Group
Fax: +1 618.654.2351
www.basler.com
info@basler.com

INTRODUCTION

This publication describes the capabilities and operation of PRP 320 and PRP 340 Synchronous Motor Pullout Relays. The PRP 320 is designed for use in 60 hertz applications and the PRP 340 is designed for use in 50 hertz applications.

PURPOSE

The PRP 320/340 protects a synchronous motor from damage during increased loading or decreased excitation conditions. During these conditions, the motor can pull out of synchronization with its rotating field.

When the motor power factor decreases below a preset value for a preselected time delay, the PRP 320/340 output relay energizes. The output relay contacts can be used to take the motor off line or operate an alarm.

The power factor trip point is adjustable over the range of 0.95 to 0.80, lagging. The time delay can be set from 0.25 to 1.5 seconds.

An energized output relay is reset manually by operating a pushbutton on the front panel or automatically if operating power is interrupted. A reset is not possible if the motor power factor remains outside the normal range.

SPECIFICATIONS

PRP 320/340 electrical and physical specifications are listed in the following paragraphs.

Operating/Sensing Voltage Input

Nominal Voltage (Line-to-Line): 120, 208, 240, or 480 Vac
Nominal Frequency
 PRP 320: 60 Hz
 PRP 340: 50 Hz
Burden: 6 VA, I lags V by 40°
Terminals: 1 (common), 2 (120 Vac), 3 (208 Vac), 4 (240 Vac), 5 (480 Vac)

Sensing Current Input

Nominal Current Range: 2 to 5 Aac (Must use 0.3% accuracy-class sensing CT.)
Burden: 7 VA, I lags V by 28°
Overload Rating: Withstands up to 5 times nominal current for brief durations.
Terminals: 6, 7

Output Contacts

Configuration: SPDT (Form C)
Rating: 10 Aac at 120 Vac, resistive
Terminals: 8 (NC), 9 (Common), 10 (NO)

Adjustment Ranges

Power Factor: 0.95 to 0.80, lagging
Time Delay: 0.25 to 1.5 s

Operating Temperature

Range: -20 to 50°C (-4 to 155°F)

Weight

Net: 3.4 kg (7.5 lb)
Shipping: 4.08 kg (9.0 lb)

Publication 9022900993	Revision B		First Printing: 09/73 Revised: 06/10	Copyright 2010
----------------------------------	----------------------	--	---	--------------------------

MOUNTING

The PRP 320/340 can be mounted in any position. Mounting dimensions are illustrated in Figure 1.

CONNECTIONS

Make PRP 320/340 connections in accordance with the interconnection diagram of Figure 2. The applied voltage should be obtained directly from the motor input lines and must be applied to the proper terminals. Because the PRP 320/340 functions according to the power factor sensed at its terminals, the phase shift introduced by any reactive components (such as isolation transformers) connected between the PRP 320/340 and the load must be considered.

The PRP 320/340 must be connected to provide the correct phase relationship between the voltage and current. Voltage is sensed between the lines shown in Figure 2, while the current is sensed on the third line. Phase rotation and current transformer polarity must be observed.

RESET OPERATION

The following operations should be performed only with the PRP 320/340 removed from service and no operating power applied.

Automatic Reset

To enable automatic reset operation, remove the jumper connected across terminals 11 and 12. This action will disable the front-panel reset switch. When the PRP 320/340 is configured for automatic reset operation, the front-panel reset switch should be labeled as "INACTIVE".

Remote Reset

To add remote reset capability, replace the jumper across terminals 11 and 12 with an external, normally-closed, momentary-action switch.

MAINTENANCE

The PRP 320/340 requires no maintenance other than the periodic removal of accumulated dust.

TESTING

If desired, PRP 320/340 operation can be verified through the following functional test.

1. Connect the PRP 320/340 as shown in Figure 3. The phase rotation must be A-B-C.
2. Adjust the variable transformer to the middle of its range and adjust the front-panel power factor control to one of the power factor settings listed in Table 1. Adjust the front-panel time delay control to its minimum setting.
3. Slowly adjust the variable transformer clockwise until the PRP 320/340 trips after the time delay expires. A trip can be detected by monitoring terminals 9 and 10 for continuity with an ohmmeter. Verify that the measured voltage falls within the voltage range listed in Table 1.
4. Repeat steps 2 and 3 for any of the desired power factor settings listed in Table 1.

Table 1. Power Factor Settings and Pickup Values

Power Factor Setting	Voltage Measured From Variable Transformer Wiper to Phase A
0.95	80.11 to 88.55 Vac
0.90	71.25 to 78.75 Vac
0.85	63.55 to 70.23 Vac
0.80	56.15 to 62.06 Vac
0.75	48.64 to 53.76 Vac

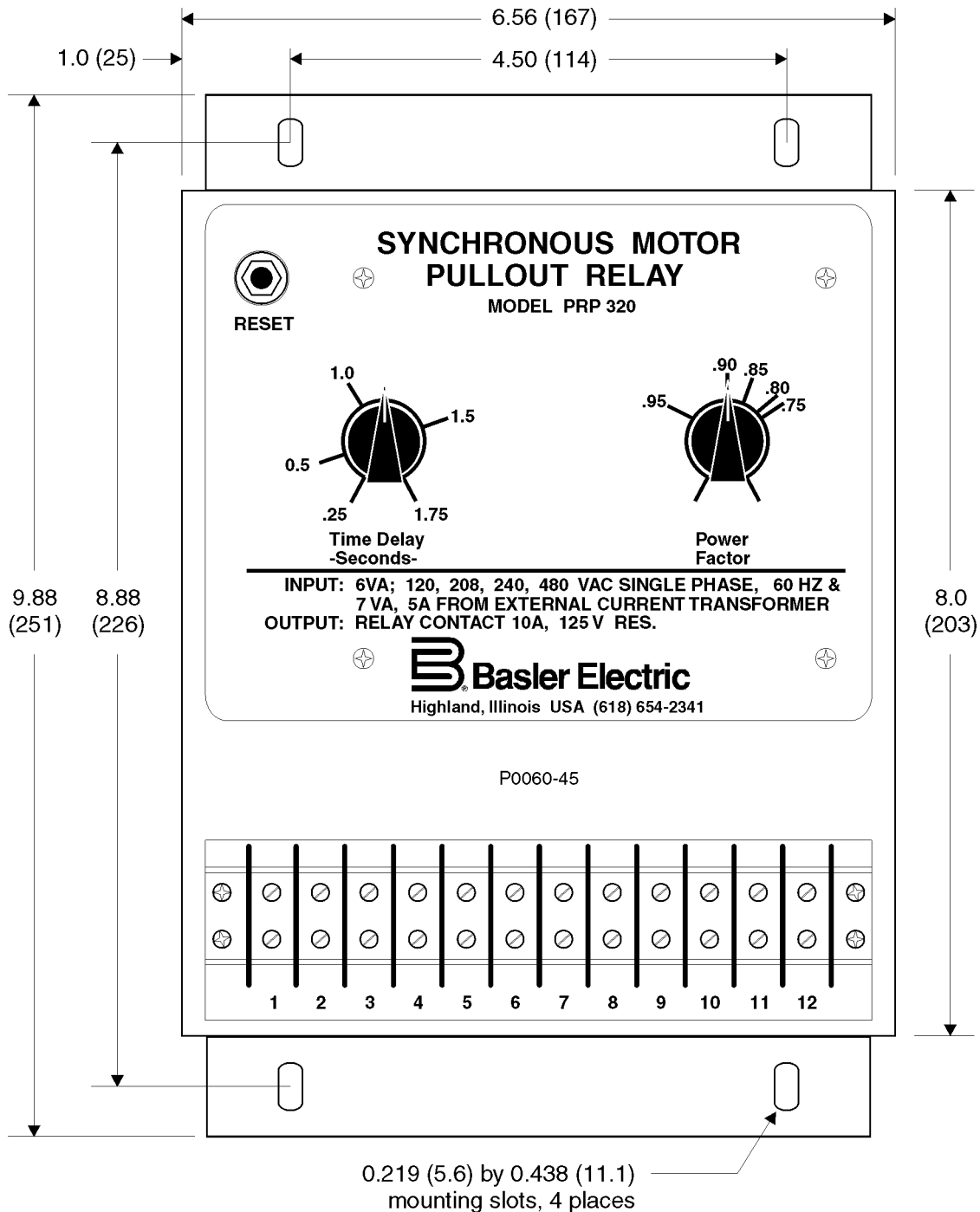

NOTES

1. Dimensions are in inches with millimeters in parenthesis.
2. Maximum mounting depth is 5.12 (130).

Figure 1. Outline and Mounting Dimensions

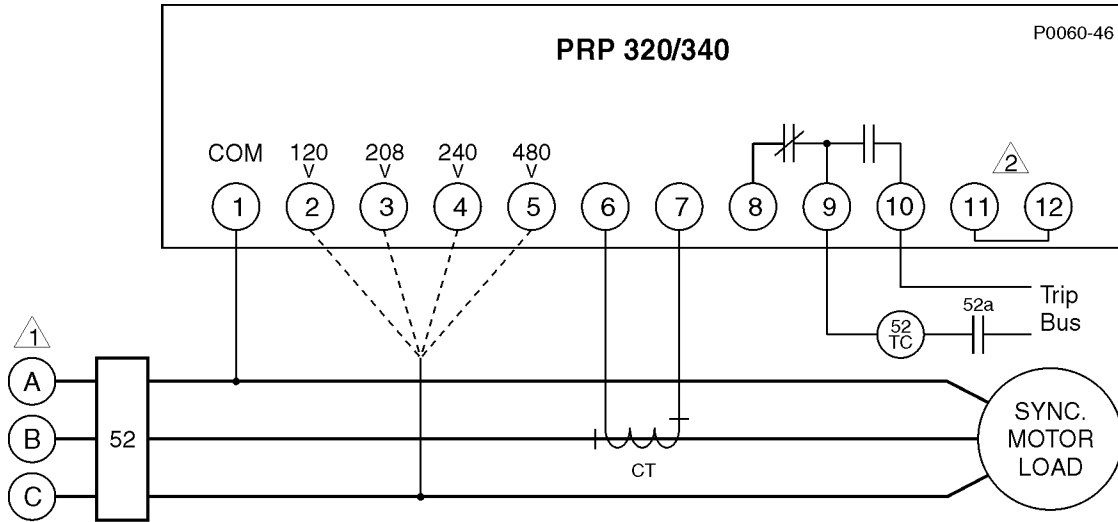

- NOTES**
- 1 Phase rotation must be ABC.
 - 2 See *Reset Operation* paragraphs for PRP 320/340 reset options.

- LEGEND**
- 52: power circuit breaker
 - 52TC: breaker trip coil
 - 52a: breaker auxiliary contact

Figure 2. Interconnection Diagram

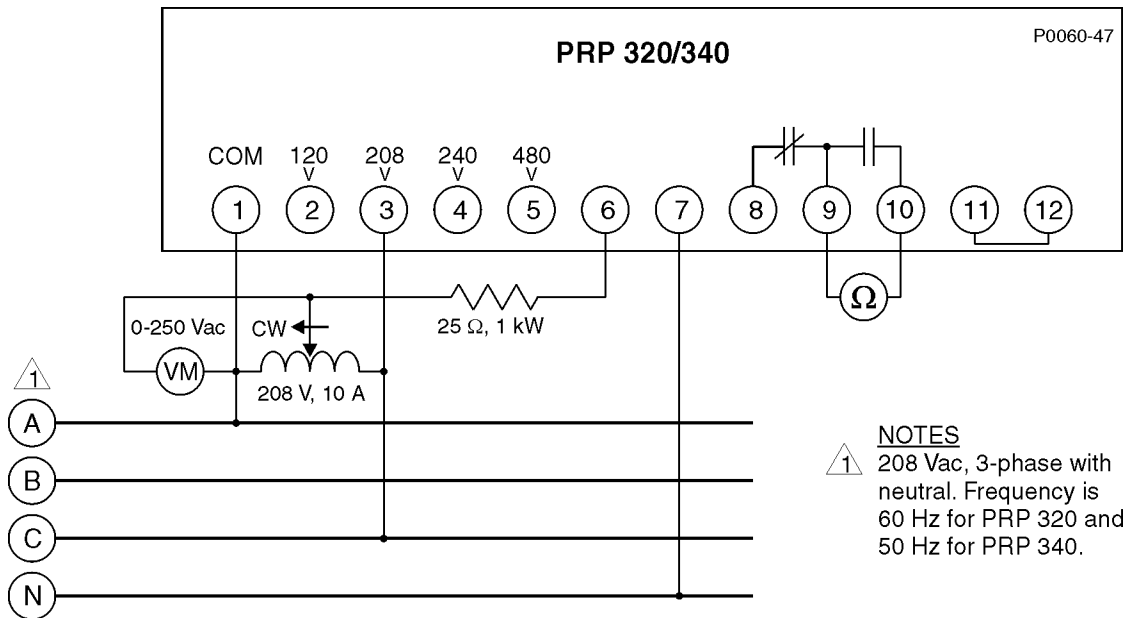

- NOTES**
- 1 208 Vac, 3-phase with neutral. Frequency is 60 Hz for PRP 320 and 50 Hz for PRP 340.

Figure 3. Test Connections