

INSTRUCTION MANUAL

FOR

DIGITAL GENSET CONTROLLER

DGC-2000

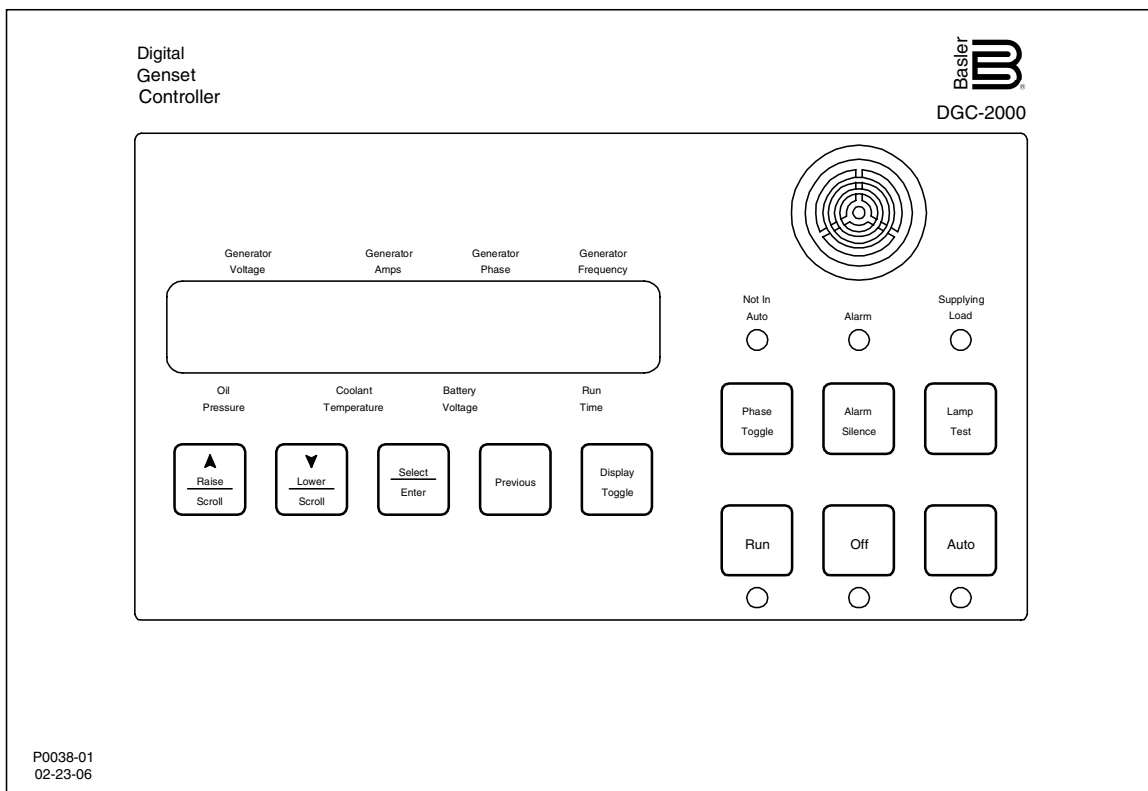

INTRODUCTION

This instruction manual provides information about the operation and installation of the DGC-2000 Digital Genset Controller. To accomplish this, the following information is provided:

- General Information and Specifications
- Controls and Indicators
- Functional Description
- Installation
- Maintenance

WARNING!

To avoid personal injury or equipment damage, only qualified personnel should perform the procedures in this manual.

NOTE

Be sure that the relay is hard-wired to earth ground with no smaller than 12 AWG copper wire attached to the ground terminal on the rear of the unit case. When the relay is configured in a system with other devices, it is recommended to use a separate lead to the ground bus from each unit.

First Printing: November 1997

Printed in USA

© 1997–1999, 2006 Basler Electric, Highland Illinois 62249 USA

All Rights Reserved

March 2006

CONFIDENTIAL INFORMATION

of Basler Electric, Highland Illinois, USA. It is loaned for confidential use, subject to return on request, and with the mutual understanding that it will not be used in any manner detrimental to the interest of Basler Electric.

It is not the intention of this manual to cover all details and variations in equipment, nor does this manual provide data for every possible contingency regarding installation or operation. The availability and design of all features and options are subject to modification without notice. Should further information be required, contact Basler Electric.

**BASLER ELECTRIC
ROUTE 143, BOX 269
HIGHLAND IL 62249 USA**

<http://www.basler.com>, info@basler.com

PHONE +1 618.654.2341

FAX +1 618.654.2351

REVISION HISTORY

The following information provides a historical summary of the changes made to DGC-2000 Instruction Manual 9305500990. Revisions are listed in chronological order.

Manual Revision and Date	Change
—, 11/97	<ul style="list-style-type: none"> • Initial release
A, 05/98	<ul style="list-style-type: none"> • Incorporated information concerning Low Coolant Level. This included adding the function on page 1-1 and to the contact sensing inputs specifications. • Added the input to Figure 2-2. Added the description of the input on page 3-2. • Corrected Figure 3-4 • Added test procedures for low coolant level in Section 5. • Updated Figures 4-4 through 4-6 and 5-1 to add the low coolant level input. • In Section 6, changed holding register 40378 function to low coolant level. • Added alarm to Figure 7-19. • Added Section 8.
B, 09/98	<ul style="list-style-type: none"> • Changed contact ratings for protection features in Section 1. • Changed all instances of “battery charger failure” to “air damper”.
C, 04/99	<ul style="list-style-type: none"> • In specifications of Section 1, qualified accuracies at 25°C, added UL recognition and CSA certification, and corrected fuel level sensor and oil pressure sensor part numbers. • Changed Figure 4-3 to show UL/CSA symbols • Updated percent fuel level test procedures in Section 5.
D, 03/06	<ul style="list-style-type: none"> • Replaced all references to “DGC-2000 Windows® Software” with “BESTCOMS Software”. • Corrected entries for holding registers 40427–40429 and 40435–40437 in Section 6. • Added “Calculating Total Kilowatt-Hours” material and equations to Section 6. • In Section 7: <ul style="list-style-type: none"> ○ Changed section title to “BESTCOMS Software”. ○ Updated operating requirements for BESTCOMS. ○ Revised BESTCOMS installation instructions to accommodate CD-ROM with auto-start menu. ○ Replaced Figure 7-2 with updated Comm Port dialog box. • Moved Section 8, <i>Manual Change Information</i> to introduction area of the manual.

This page intentionally left blank.

CONTENTS

SECTION 1 • GENERAL INFORMATION.....	1-1
DESCRIPTION	1-1
FEATURES	1-1
FUNCTIONS.....	1-1
OUTPUTS	1-1
SPECIFICATIONS.....	1-2
Current Sensing Inputs	1-2
Voltage Sensing Inputs	1-2
Frequency	1-2
Contact Sensing Inputs.....	1-2
Engine System Inputs.....	1-2
Output Contacts	1-3
Calculated Data	1-3
Hardware.....	1-4
SECTION 2 • HUMAN-MACHINE INTERFACE.....	2-1
INTRODUCTION.....	2-1
FRONT PANEL DISPLAY	2-1
DGC-2000 CONNECTIONS.....	2-2
SECTION 3 • FUNCTIONAL DESCRIPTION.....	3-1
GENERAL	3-1
INPUTS	3-2
Battery Operating Voltage.....	3-2
Contact Sensing Inputs.....	3-2
Sending Unit Inputs.....	3-3
Speed Signal Inputs.....	3-3
Voltage Inputs	3-3
Current Inputs	3-3
Serial Communication Port	3-3
MICROPROCESSOR.....	3-3
Formulas	3-3
Related Circuits.....	3-4
OUTPUTS	3-4
SOFTWARE	3-5
Display Modes	3-5
Normal Mode	3-5
Menu Mode	3-6
Exiting Menu Mode	3-14
Modifying Setpoints.....	3-15
Alternate Display Mode.....	3-16
FACTORY KEY CODE SETTING.....	3-16
ALLOWABLE KEY CODE PUSHBUTTONS.....	3-17
PARAMETERS AND DEFAULT SETTINGS	3-17
All Parameters	3-17
SECTION 4 • INSTALLATION.....	4-1
GENERAL	4-1
HARDWARE.....	4-1
MOUNTING	4-1
CONNECTIONS.....	4-3
COMMUNICATION CONNECTORS AND SETTINGS.....	4-7
RS-232 Connector	4-7
Communication Settings	4-7
SECTION 5 • TESTING.....	5-1
INTRODUCTION.....	5-1

EQUIPMENT REQUIRED	5-1
INITIAL TEST PROCEDURE	5-1
METERING TEST PROCEDURES	5-3
Metering Battery and Generator Voltages	5-3
Metering Bus Voltages	5-5
Metering Generator Current	5-5
Oil Pressure	5-5
Coolant Temperature	5-5
Percent Fuel Level	5-5
Engine Speed (RPM)	5-5
Generator Power Factor	5-6
Generator kW and kVA	5-6
CRANKING TEST PROCEDURES	5-6
Crank Cycle	5-6
Running	5-7
PROTECTIVE FUNCTIONS	5-7
Overcrank	5-7
Overspeed	5-7
Low Oil Pressure	5-7
High Coolant Temperature	5-8
Air Damper	5-8
Emergency Stop	5-8
Low Coolant Level	5-9
SECTION 6 • MODBUS™ COMMUNICATIONS	6-1
GENERAL	6-1
Interface	6-1
Applications	6-1
INTRODUCTION TO MODBUS™ PROTOCOL	6-1
DGC-2000 MODBUS™ PROTOCOL	6-1
Message Structure	6-2
Device Address Field	6-2
Function Code Field	6-2
Data Block field	6-2
Error Check Field	6-2
SERIAL TRANSMISSION DETAILS	6-2
MESSAGE FRAMING AND TIMING CONSIDERATIONS	6-3
ERROR HANDLING AND EXCEPTION RESPONSES	6-3
COMMUNICATION HARDWARE REQUIREMENTS	6-3
DETAILED MESSAGE QUERY AND RESPONSE	6-3
Read Holding Registers Query	6-3
Read Holding Registers Response	6-4
Return Query Data	6-4
Return Query	6-5
Return Response	6-5
Preset Multiple Register Query	6-5
Preset Multiple Register Response	6-6
CHANGING THE LOGON PASSWORD	6-6
DATA FORMATS	6-7
Double Precision Data Format	6-7
Triple Precision Data Format	6-7
Error Check	6-8
Settings Source Register (40081)	6-8
Saving Settings Register (40082)	6-8
CALCULATING TOTAL KILOWATT-HOURS	6-8
MAPPING REGISTERS INTO MODICON ADDRESS SPACE	6-8
Conventions	6-8
Register Table	6-9

SECTION 7 • BESTCOMS SOFTWARE.....	7-1
INTRODUCTION.....	7-1
INITIALIZING COMMUNICATION WITH BESTCOMS.....	7-1
CHANGING BESTCOMS COMMUNICATION PARAMETERS	7-3
CHANGING LOGON PASSWORDS.....	7-4
REMOTE START AND STOP OF GENERATOR.....	7-4
CHANGING SETTINGS.....	7-5
MENUS.....	7-5
SETTINGS DEFINITIONS.....	7-6
APPENDIX A • DGC-2000 SETTINGS RECORD.....	A-1

This page intentionally left blank.

SECTION 1 • GENERAL INFORMATION

DESCRIPTION

DGC-2000 Digital Genset Controllers use microprocessor-based technology to provide integrated engine-generator set control, protection, and metering in a single package. Microprocessor-based technology allows for exact measurement, setpoint adjustment, and timing functions. The DGC-2000 allows for quick and simple operation from the front panel or through serial communication. The DGC-2000 can communicate over a network using the Modbus™ communication protocol or with a personal computer (PC) operating BESTCOMS software. Because of the low sensing burden in the DGC-2000, neither dedicated potential transformers nor current transformers are required. The liquid crystal display (LCD) on the front panel operates over a wide temperature range and has backlighting to enable viewing under any ambient light condition. This combination of features in the DGC-2000 yields significant savings in installation and setup costs.

FEATURES

DGC-2000 Digital Genset Controllers have the following features.

- Packaged in metal cases for improved electromagnetic compatibility.
 - Designed for use in harsh environments.
 - Resistant to high moisture, salt fog, humidity, dust, dirt, and chemical contaminants.
 - Resistant to the entrance of insects and rodents.
 - Suitable for mounting in any top mount enclosure.
 - Suitable for controlling isolated generating systems or paralleled generating systems.
 - Serial communication and BESTCOMS software simplifies and enhances access to setup parameters. BESTCOMS also provides real time monitoring and control. When combined with a modem and a telephone line, monitoring and control is possible from any remote location.
-

FUNCTIONS

DGC 2000 Digital Genset Controllers perform the following functions.

- Engine cranking control
 - Generator voltage metering
 - Bus voltage metering
 - Generator frequency metering
 - Bus frequency metering
 - Generator current metering
 - Engine coolant temperature metering
 - Engine coolant temperature protection
 - Engine oil pressure metering
 - Engine oil pressure protection
 - Fuel level sensing
 - Fuel level protection
 - Engine cool down
 - Watt metering
 - VA metering
 - Air box control
 - Engine rpm metering
 - Power factor metering
 - Watthour metering
 - Engine run time metering
 - Battery voltage metering
 - Battery condition monitoring
 - Engine maintenance monitoring
 - Overload protection
 - Serial communication with Modbus™ protocol or BESTCOMS software
 - Low coolant level
-

OUTPUTS

There are thirteen isolated form A (SPST) output contacts. Four output contacts are used for engine cranking control and the remaining nine output contacts can be used for a variety of protection features.

SPECIFICATIONS

DGC-2000 Digital Genset Controllers have the following features and capabilities.

Current Sensing Inputs

Current range	
1 Ampere Input	0.02 to 1 ampere continuously, 2.0 amperes for one second
5 Ampere Input	0.1 to 5 amperes continuously, 10.0 amperes for one second
Accuracy	$\pm 2\%$ of reading or ± 2 amperes whichever is greater
Burden	1 volt-ampere

Voltage Sensing Inputs

Range	12 to 576 volts rms, 50 or 60 hertz continuously, 720 volts rms for one second
Accuracy	$\pm 2\%$ of reading or ± 2 volts whichever is greater
Burden	1 VA

Frequency

Range	4 to 70 Hz
Accuracy	$\pm 0.25\%$ of reading or ± 0.2 Hz whichever is greater

Contact Sensing Inputs

Emergency Stop	Normally closed dry contact
Air Damper	Normally open dry contact
Automatic Transfer	Normally open dry contact
Battery Charger Fail	Normally open dry contact
Low Coolant Level	Normally open dry contact

Engine System Inputs

Fuel Level Sensing

	Recommended fuel level transmitter: ISSPRO, part number R-8925 or equivalent
Range	240 to 33 ohms corresponds to 0 to 100%
Accuracy	$\pm 0.5\%$ of indication or 1% whichever is greater at 25°C

Coolant Temperature Sensing

	Recommended coolant temperature transmitter: Stewart-Warner, part number 334-P or equivalent
Range	62.6 to 637.5 ohms
Accuracy	From 37°C (99°F) to 115°C (239°F): $\pm 0.5\%$ of the reading or ± 1 degree whichever is greater at 25°C ambient

Oil Pressure Sensing

	Unit displays 0 below 104 kilopascals (15 psi). Recommended oil pressure transmitter: Stewart-Warner (part number 411-K or equivalent)
Range	34 to 240 ohms
Accuracy	From 0 to 690 kilopascals: $\pm 0.5\%$ of reading or ± 1 kilopascals whichever is greater at 25°C. From 0 to 100 psi: $\pm 0.5\%$ of reading or ± 1 psi whichever is greater at 25°C

Battery Voltage Sensing

Range	12 or 24 Vdc nominal, 8 to 32 Vdc, battery dip ride through to 3 volts for 0.75 seconds
Accuracy	±0.5% of reading or ±0.1 Vdc whichever is greater at 25°C
Burden	16 W maximum

Magnetic Pickup Sensing

Voltage Range	3 volts peak (during cranking) to 35 volts peak continuous into 10 kΩ
Frequency Range	32 to 10,000 Hz

Engine Alternator Voltage Sensing

Voltage Range	2 volts peak to 50 volts peak
Frequency Range	100 to 900 Hz nominal

Engine RPM Sensing

Range	750 to 3600 RPM
Accuracy	±0.5% of reading or ±1 RPM whichever is greater at 25°C

Output Contacts

Contact Ratings For Engine Cranking Control

The MASTER START, AUXILIARY START, FUEL SOLENOID, and ENGINE RUN relays are rated for 10 amperes at 24 Vdc, make, break, and carry

Contact Ratings For Protection Features

The PRE-START, ALARM, PRE-ALARM, LOW OIL PRESSURE, LOW COOLANT TEMPERATURE, HIGH COOLANT TEMPERATURE, OVERCRANK, OVERSPEED, and AIR DAMPER relays are rated for 2 amperes at 24 Vdc, make, break, and carry

Calculated Data

Power Factor (PF)

Range	+1.0 to -1.0, both leading and lagging
Accuracy	±0.01 PF of indication at 25°C

Kilo Volt-Amperes

Range	0 to 9,999 kVA
Accuracy	±0.5% of reading or ±0.1 kVA whichever is greater at 25°C

Kilowatts

Range	0 to 9,999 kW
Accuracy	±0.5% of reading or ±0.1 kW whichever is greater at 25°C

Kilowatt Hours

Range	0 to 999,999,999 kWh
Accuracy	±0.5% of reading or ±1 kWh whichever is greater at 25°C

Engine Run Time

Range	0 to 99,999 hours
Accuracy	±0.5% of reading or ±1 hour whichever is greater at 25°C

Maintenance Interval

Range 0 to 5,000 hours
Accuracy $\pm 0.5\%$ of reading or ± 1 hour whichever is greater at 25°C

Hardware

Communication Port

Interface Rear RS-232 9600 baud, 8N1 full duplex
Protocols Rear RS-232 Modbus™

Isolation

2000 Vac at 50/60 Hz for one minute between ground and voltage sensing inputs. 500 Vac at 50/60 Hz for one minute between any of the following groups

- Voltage Sensing - 70mA
- Battery, Contact Sensing, and Remote Panel - 42 mA
- Current Transformer - 8mA
- Communications Port - RS-232 - 6 mA
- Contact Outputs - 23 mA

Impulse

Qualified to IEC 255-5

Surge Withstand Capability

Oscillatory Qualified to ANSI/IEEE C37.90.1-1989 *Standard Surge Withstand Capability (SWC) Tests for Protective Relays and Relay Systems.*
Fast Transient Qualified to ANSI/IEEE C37.90.1-1989 *Standard Surge Withstand Capability (SWC) Tests for Protective Relays and Relay Systems.*

Radio Frequency Interference (RFI)

Type tested using a 5 watt, hand-held transceiver operating at random frequencies centered around 144 and 440 megahertz with the antenna located within 6 inches (15 centimeters) of the device in both vertical and horizontal planes

UL Recognized/CSA Certified

UL Recognized per Standard 508, UL File No. E97033. CSA Certified per Standard CAN/CSA-C22.2 No. 14-M91, CSA File No. LR 23131

Environment

Operating Temperature Range -40°C to 70°C (-40°F to 158°F)
Storage Temperature Range -40°C to 85°C (-40°F to 185°F)

Salt Fog

Qualified to ASTM-117B-1989 with the device un-powered for the 100 hour test duration

Vibration

The device withstands 2 g in each of three mutually perpendicular planes, swept over the range of 10 to 500 Hz for a total of six sweeps, 15 minutes each sweep, without structural damage or degradation of performance

Shock

15 g

Weight

Maximum weight 5.75 pounds (2.61 kilograms)

SECTION 2 • HUMAN-MACHINE INTERFACE

INTRODUCTION

This section provides a description of the DGC-2000 controls, indicators, and user connections.

FRONT PANEL DISPLAY

Figure 2-1 shows the front panel human-machine interface (HMI) for a DGC-2000. Descriptions in Table 2-1 refer to callouts in Figure 2-1.

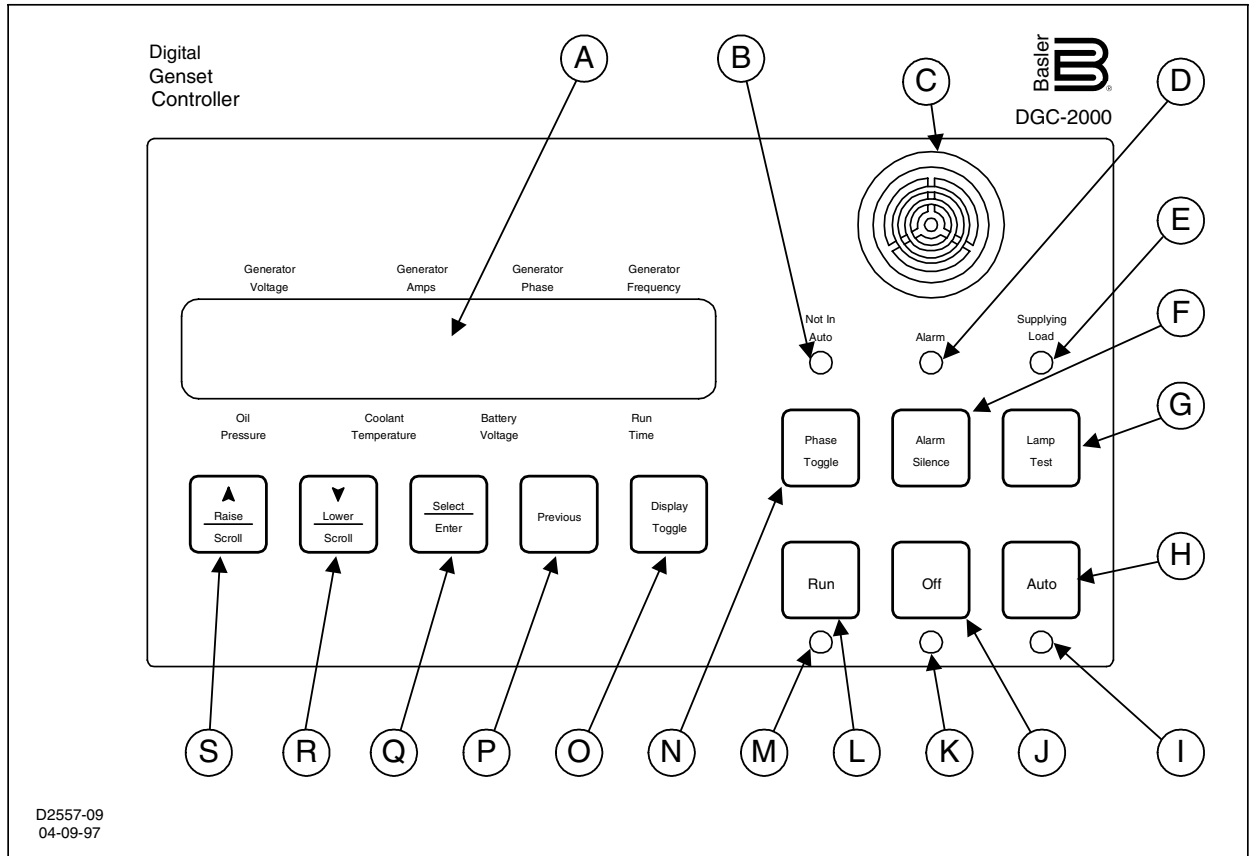

Figure 2-1. DGC-2000 Front Panel

Table 2-1. DGC-2000 HMI (Controls And Indicators)

A	Two line by twenty character LCD provides the primary visual interface for metering, alarms, pre-alarms, and protective functions. In the normal mode, labels appear above and below the display. In the alternate display mode, labels and the displayed value appear on the display.
B	Red LED turns ON when the device is not in the AUTO mode.
C	Audible alarm annunciates when the unit is not in AUTO and when alarms and pre-alarms occur.

Table 2-1. DGC-2000 HMI (Continued)

D	Red LED turns ON continuously for all alarm conditions and flashes for pre-alarm conditions.
E	Green LED turns ON when the generator is supplying more than two percent of rated current.
F	Pushbutton used to silence the audible alarm.
G	Pushbutton used to exercise all segments of the LCD and to illuminate all LED's.
H	Pushbutton used to place the device in AUTO mode.
I	Green LED turns ON when the device is in the AUTO mode.
J	Pushbutton used to place the unit in the OFF mode.
K	Red LED turns ON when the device is in the OFF mode.
L	Pushbutton used to place the device in the RUN mode.
M	Green LED turns ON when the device is in the RUN mode.
N	Pushbutton used to scroll through the displays available in the normal display mode.
O	Pushbutton used to scroll through the display modes.
P	Pushbutton used to scroll through previous menu levels.
Q	Pushbutton used to enter menu sublevels and select set points.
R	Pushbutton used to scroll backward through the menus and to decrement set points.
S	Pushbutton used to scroll forward through the menus and to increment set points.

DGC-2000 CONNECTIONS

Compression type terminal strips make wiring the DGC-2000 a simple task. These connections accept one #10 or two #14 AWG wires. These operations are made even easier by user friendly labeling of the terminal strips. Once wired, these terminals can be removed as an assembly and facilitate DGC-2000 replacement for out of circuit testing or maintenance. Figure 2-2 shows the DGC-2000 rear panel terminal connections. Descriptions in Table 2-2 refer to callouts in Figure 2-2.

Table 2-2. DGC-2000 Connections

A	Connection points for the speed sensing inputs.
B	Connection points for voltage sensing inputs.
C	Connection points for current sensing inputs.
D	Connection points for relay output contacts.
E	Connection point for chassis ground.
F	RS-232 serial communication port.
G	Connection points for remote displays in accordance with the National Fire Protection Agency specifications.
H	Connection points for operating power.
I	Connection points for contact sensing inputs.
J	Connection points for sending unit inputs.

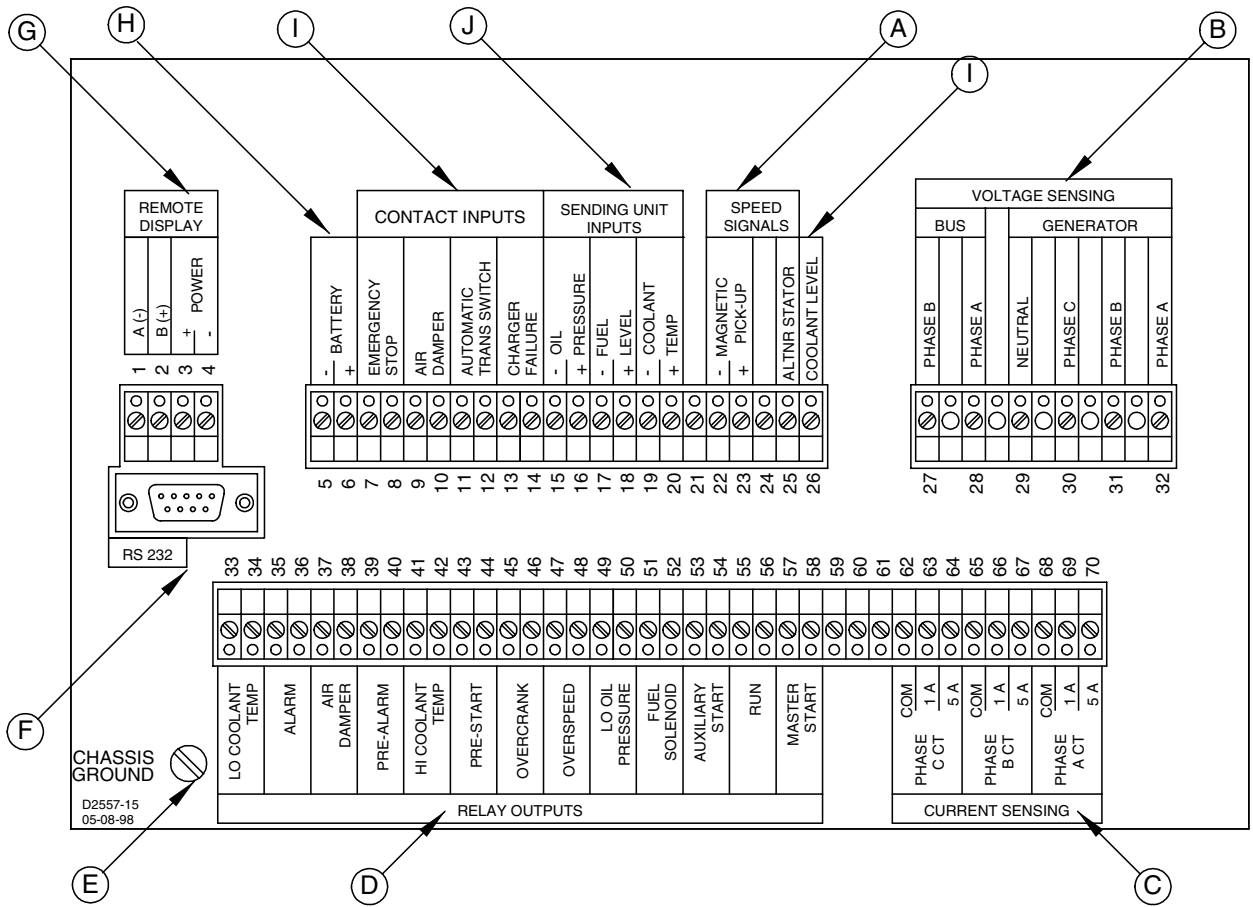

Figure 2-2. DGC-2000 Digital Genset Controller Rear Panel

This page intentionally left blank.

SECTION 3 • FUNCTIONAL DESCRIPTION

GENERAL

DGC-2000 Digital Genset Controllers use microprocessor based technology to provide integrated engine-generator set control, protection, and metering in a single package. Microprocessor based technology allows for exact measurement, set point adjustment, and timing functions. Refer to the following paragraphs for the DGC-2000 functional description.

Circuit functional description is divided into *Inputs*, *Microprocessor*, *Outputs*, and *Software*. Circuit functions illustrated in Figure 3-1 are described in the following paragraphs.

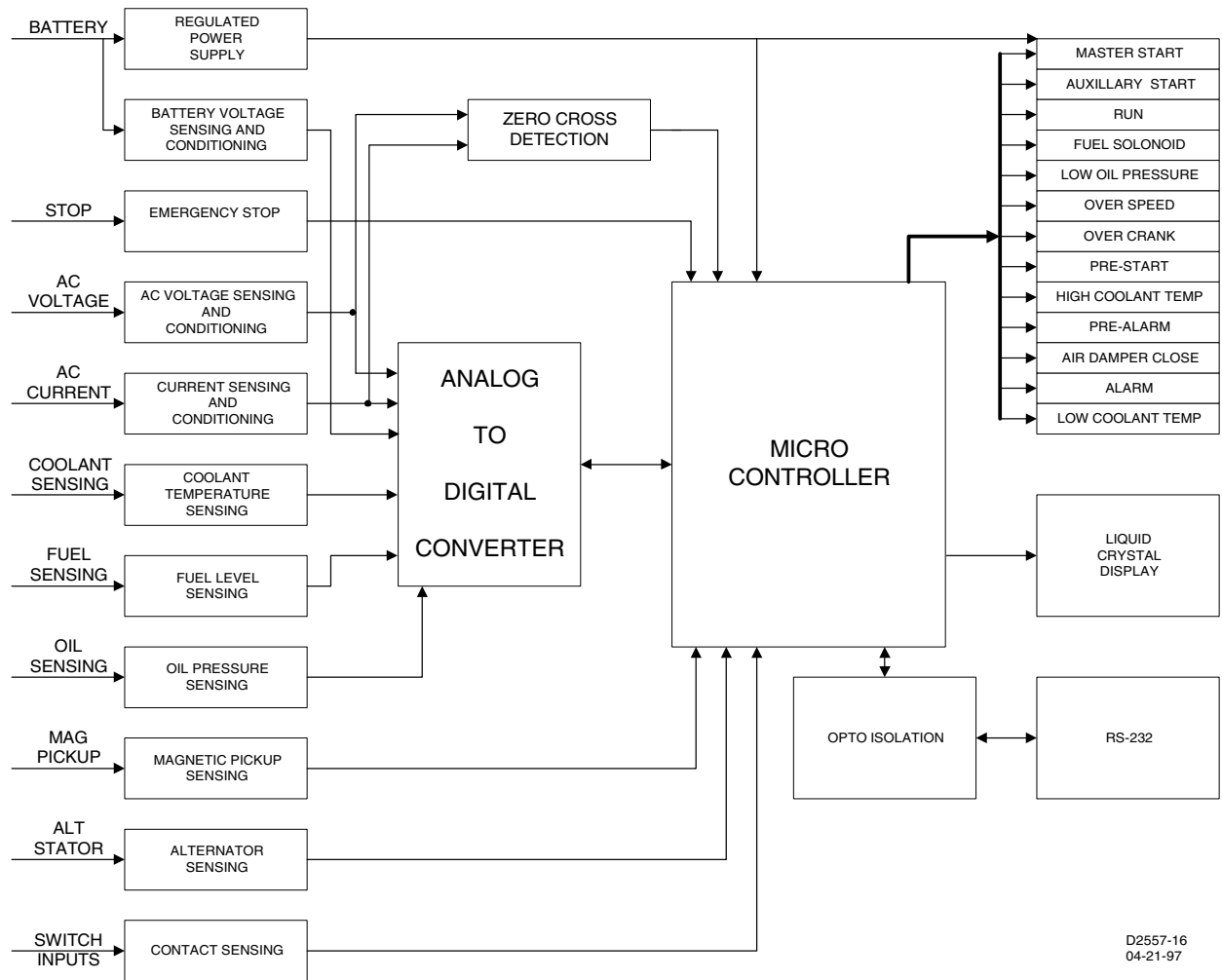

Figure 3-1. DGC-2000 Functional Block Diagram

INPUTS

There are seven types of inputs to the DGC-2000 Controller. They are:

- Operating (Battery) DC Power
- Contact Sensing
- Sending Units
- Speed Signals
- Voltage Sensing
- Current Sensing
- Serial Communications RS-232 Port

The following paragraphs describe these inputs.

Battery Operating Voltage

Required operating voltage is a nominal 12 or 24 Vdc. Operating voltage may be in the range of 8 to 32 Vdc. An internal switching power supply uses the battery voltage to generate a +12 Vdc, -12 Vdc, +5 Vdc, a stable +5 Vdc reference, and an isolated +5 Vdc. The isolated +5 Vdc supply is for the RS-232 serial communications port. The dc reference voltage is for internal use.

Battery operating voltage is conditioned (filtered and reduced to a level suitable for microprocessor input) and sensed by the microprocessor.

Contact Sensing Inputs

Five external contact sensing inputs (Emergency Stop, Air Damper, Automatic Transfer Switch, Charger Failure, and Low Coolant Level) provide external stimulus to the DGC-2000 Controller. Nominal voltage(s) of the external dc source(s) must fall within the DC power supply input voltage range.

Emergency Stop

This input is continuously monitored. An open circuit indicates an Emergency Stop. Opening this circuit removes power from all output relays.

Air Damper

This input is continuously monitored by the microprocessor and is used to indicate the position of the air damper. An open circuit indicates an open air damper.

WARNING!

If the air damper is functional, an auxiliary contact from the Emergency Stop switch must be used to trip the air damper solenoid.

Automatic Transfer Switch

This input is continuously monitored by the microprocessor and is used to start the engine when in the auto mode. A closed contact initiates the start sequence.

Charger Failure

This input is continuously monitored by the microprocessor and is used to indicate that ac power is available to the battery charger. An open circuit indicates a failure of the battery charger.

Low Coolant Level

This input is continuously monitored by the microprocessor. When battery (-) potential is connected to this input, a low coolant level is indicated.

Sending Unit Inputs

Coolant temperature

A current of less than two milliamperes is provided to the coolant temperature sending unit. The developed voltage is measured and scaled for use by the internal circuitry.

Oil Pressure

A current of less than 15 milliamperes is provided to the oil pressure sending unit. The developed voltage is measured and scaled for use by the internal circuitry.

Fuel level

A current of less than 15 milliamperes is provided to the fuel level sending unit. The developed voltage is measured and scaled for use by the internal circuitry.

Speed Signal Inputs

Magnetic Pickup

The voltage from the magnetic pickup is scaled and conditioned for use by the internal circuitry as a speed signal source.

Alternator Sensing

The voltage from the engine alternator stator is scaled and conditioned for use by the internal circuitry as a speed signal source.

Voltage Inputs

Monitored generator and bus voltages are sensed and scaled to levels suitable for use by the internal circuitry. Differential amplifiers provide isolation for these inputs. Internal solid state switches select line-to-line, line-to-neutral or single-phase values. Menu selections by the user determine these switch settings.

Current Inputs

Monitored generator currents are sensed and scaled to values suitable for use by the internal circuitry. Internal current transformers provide isolation. Two taps on the primary of these transformers accommodate either one or five ampere circuits.

Serial Communication Port

This serial communication link connects via optically-isolated circuitry to the microprocessor. Enhanced access to device functions and real time, remote metering capabilities are available through this port. The DGC 2000 emulates a subset of the Modicon 984 programmable controller. BESTCOMS software provides easy access to these functions.

MICROPROCESSOR

Software programmed in the erasable programmable read-only memory (EPROM) controls the overall functionality of the device and makes all decisions based on programming and system inputs. Formulas that are used to determine the various calculated quantities and circuits related to microprocessor inputs are described in the follow paragraphs.

Formulas

Formulas used in calculating the various quantities are provided in the following paragraphs.

For line-to-neutral (V_{L-N}) voltage sensing: $V_{ab} = \sqrt{V_a^2 + V_a V_b + V_b^2}$

$$V_{bc} = \sqrt{V_b^2 + V_b V_c + V_c^2}$$

$$V_{ca} = \sqrt{V_c^2 + V_c V_a + V_a^2}$$

For all three-phase voltage sensing configurations:

kVA: kVA A Phase = ($V_{ab} \times I_a$) divided by (1000 times square-root of three)
 kVA B Phase = ($V_{bc} \times I_b$) divided by (1000 times square-root of three)
 kVA C Phase = ($V_{ca} \times I_c$) divided by (1000 times square-root of three)
 Total kVA = kVA A Phase + kVA B Phase + kVA C Phase

kW: kW A Phase = kVA A Phase times Power Factor
 kW B Phase = kVA B Phase times Power Factor
 kW C Phase = kVA C Phase times Power Factor
 Total kW = Total kVA \times PF

Power Factor (PF) = Cosine of the measured angle between voltage and current zero crossings

Related Circuits

Zero Crossing Detection

The zero crossing of the A phase voltage and the B phase current is detected and used to calculate the phase angle between the current and voltage. This zero crossing is also used to measure the bus and generator frequencies.

Signal Switching

Solid state switches, under microprocessor control, select the voltage or current sensing signal that is applied to the RMS to dc converter. The resulting signal is sent to the twelve bit analog-to-digital converter where it is digitized for use by the microprocessor.

RMS To DC Converter

Scaled and conditioned signals representing the voltage and current sensing inputs are used as the input to the RMS to dc converter. This converter output is a dc level proportional to the RMS value of the input.

Analog To Digital Converter

Signals from the RMS to dc converter, coolant temperature sensing input, fuel level sensing input, and the oil pressure sensing input are digitized by the twelve-bit analog to digital converter. The digitized information is stored in random access memory (RAM). This information is used by the microprocessor for all metering and protection functions.

OUTPUTS

Each output relay is controlled by the microprocessor and the emergency stop contact input. When the emergency stop contact input is open, all output contacts open. When the emergency stop contact input is closed and a signal is given by the microprocessor, the output contacts close. All outputs are electrically isolated from each other and from the internal circuitry. Four outputs (master start, auxiliary start, run, and fuel solenoid) are associated with engine cranking functions. The remaining nine outputs (Figure 3-1) are associated with the various alarms, pre-alarms, and pre-start.

WARNING!

If the air damper is functional, an auxiliary contact from the Emergency Stop switch must be used to trip the air damper solenoid.

SOFTWARE

Software embedded in the DGC-2000 controls all aspects of device functionality. This comprises power up initialization, front panel set up and configuration, input contact status monitoring, protective function detection and annunciation, system parameter monitoring, output contact status control, and RS-232 serial communications.

When battery power is first applied, the DGC-2000 initiates a power-up sequence. The version of embedded software is displayed on the LCD and the memory is checked. Then all configuration data stored in nonvolatile EEPROM is brought into main memory. Immediately after this, the LCD display begins the Normal mode. When the Normal mode is displayed, all enabled functions are activated and input monitoring begins.

NOTE

The run time counter, kilowatt-hour meter and maintenance timers are updated in volatile memory every minute. The updated value is saved to non-volatile memory only when auto/off/run mode of operation is changed. This can be changed either from the front panel or through the communications port. Should the battery power source fail during operation these values will not be updated and the change in value incurred since the last change of mode will not be saved. This information is irretrievably lost.

Display Modes

Pressing the **Display Toggle** pushbutton when in the Normal display mode allows the user to scroll through the Normal, Alternate, and Menu display modes. Figure 3-2 shows the top level display modes.

Normal Mode

This displays the various engine and generator parameters as described by the front panel overlay. Pressing the **Phase Toggle** pushbutton after the engine is running scrolls through the voltage and current measurements that are available.

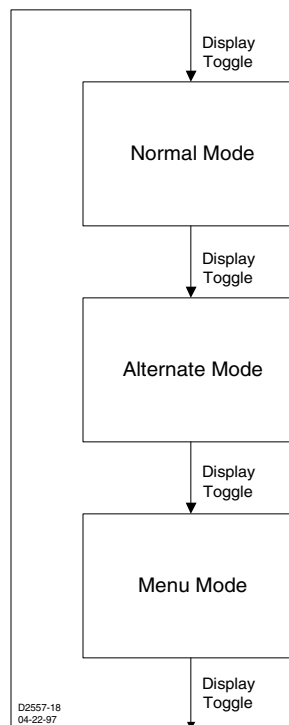

Figure 3-2. Top Level Display Modes

Menu Mode

After pressing the **Display Toggle** pushbutton twice to begin the Menu display mode (first time selects the Alternate mode), pressing **Select/Enter** begins the next level of menus. Pressing the **Raise/Scroll** or **Lower/Scroll** pushbutton (Figure 3-3) allows the user to scroll through the menu display mode screens. Pressing the **Display Toggle** pushbutton returns the display to the Normal mode.

Menu 1. Menu 1 is the alarm and pre-alarm menu. Pressing **Select/Enter** (Figure 3-4) from this menu begins the 1.x menu level. Pressing **Raise/Scroll** and **Lower/Scroll** from this menu scrolls through the 1.x menu level.

Menu 1.1. Menu 1.1 displays the overspeed alarm. Pressing **Select/Enter** begins the 1.1.1 level of menus and displays the function activation level. Pressing **Select/Enter** displays the setting. This is not adjustable from the front panel. Pressing previous goes back to the 1.1.1 level.

Pressing **Raise/Scroll** or **Lower/Scroll** begins the 1.1.2 function activation delay level of menus. Pressing **Select/Enter** displays the activation delay time once the level has been exceeded. This is not adjustable from the front panel.

Pressing **Previous** twice goes back to the 1.1 level. Pressing **Raise/Scroll** goes to the 1.2 menu level Pressing **Lower/Scroll** goes to the 1.13 menu level.

Menu 1.2. Menu 1.2 displays high coolant temperature alarm. Pressing **Select/Enter** begins the 1.2.1 level of menus and displays the function activation level. Pressing **Select/Enter** displays the setting. This is not adjustable from the front panel.

Pressing **Previous** goes back to the 1.2.1 level. Pressing **Raise/Scroll** or **Lower/Scroll** begins the 1.2.2 function activation delay level of menus. Pressing **Select/Enter** displays the activation delay time once the engine crank disconnect speed is exceeded. This is not adjustable from the front panel.

Pressing **Previous** twice goes back to the 1.2 level. Pressing **Raise/Scroll** goes to the 1.3 menu level Pressing **Lower/Scroll** goes to the 1.1 menu level.

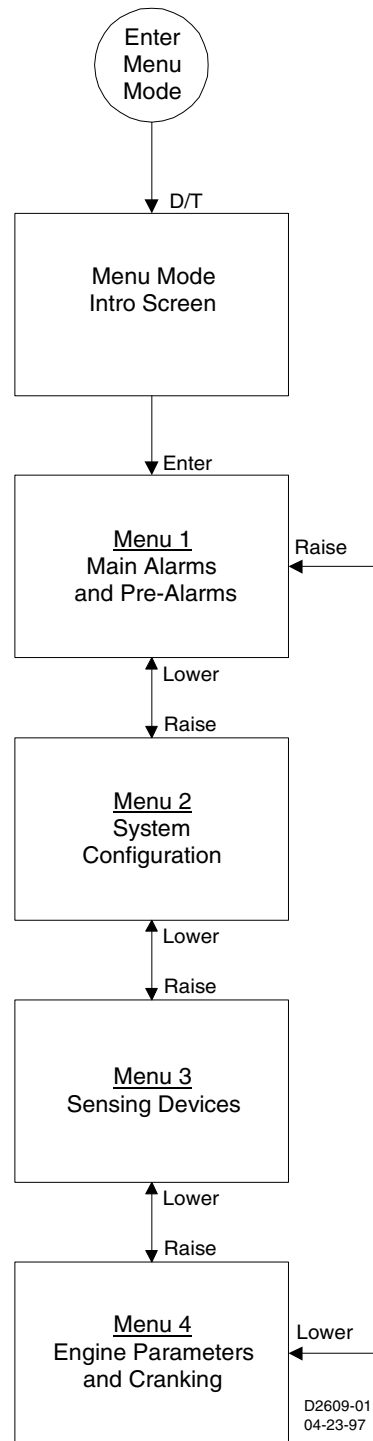

Figure 3-3. Menu Display Modes

Pressing **Previous** twice goes back to the 1.3 level. Pressing **Raise/Scroll** goes to the 1.4 menu level
Pressing **Lower/Scroll** goes to the 1.2 menu level.

Menu 1.4. Menu 1.4 displays low coolant temperature pre-alarm. Pressing **Select/Enter** begins the 1.4.1 level of menus and displays the function activation level. Pressing **Select/Enter** displays the setting. This is not adjustable from the front panel.

Pressing **Previous** goes back to the 1.4.1 level. Pressing **Raise/Scroll** or **Lower/Scroll** begins the 1.4.2 function activation delay level of menus. Pressing **Select/Enter** displays the activation delay time once the level has been exceeded. This is not adjustable from the front panel.

Pressing **Previous** twice goes back to the 1.4 level. Pressing **Raise/Scroll** goes to the 1.5 menu level
Pressing **Lower/Scroll** goes to the 1.3 menu level.

Menu 1.5. Menu 1.5 displays low oil pressure alarm. Pressing **Select/Enter** begins the 1.5.1 level of menus and displays the function activation level. Pressing **Select/Enter** displays the setting. This is not adjustable from the front panel.

Pressing **Previous** goes back to the 1.5.1 level. Pressing **Raise/Scroll** or **Lower/Scroll** begins the 1.5.2 function activation delay level of menus. Pressing **Select/Enter** displays the activation delay time once the engine crank disconnect speed is exceeded. This is not adjustable from the front panel.

Pressing **Previous** twice goes back to the 1.5 level. Pressing **Raise/Scroll** goes to the 1.6 menu level
Pressing **Lower/Scroll** goes to the 1.4 menu level.

Menu 1.6. Menu 1.6 displays low oil pressure pre-alarm. Pressing **Select/Enter** begins the 1.6.1 level of menus and displays the function activation level. Pressing **Select/Enter** displays the setting. This is not adjustable from the front panel.

Pressing **Previous** goes back to the 1.6.1 level. Pressing **Raise/Scroll** or **Lower/Scroll** begins the 1.6.2 function activation delay level of menus. Pressing **Select/Enter** displays the activation delay time once the engine crank disconnect speed is exceeded. This is not adjustable from the front panel.

Pressing **Previous** twice goes back to the 1.6 level. Pressing **Raise/Scroll** goes to the 1.7 menu level
Pressing **Lower/Scroll** goes to the 1.5 menu level.

Menu 1.7. Menu 1.7 displays low fuel level pre-alarm. Pressing **Select/Enter** begins the 1.7.1 level of menus and displays the function activation level. Pressing **Select/Enter** displays the setting. This is adjustable from the front panel.

Pressing **Previous** goes back to the 1.7.1 level. Pressing **Raise/Scroll** or **Lower/Scroll** begins the 1.7.2 function activation delay level of menus. Pressing **Select/Enter** displays the activation delay time once the level has been exceeded. After pressing **Raise/Scroll** or **Lower/Scroll**, the user will be instructed to enter the user key code. After entering the user key code followed by pressing **Select/Enter** twice, the setting will be adjustable with the **Raise/Scroll** and **Lower/Scroll** keys. After the desired setting has been selected, press **Select/Enter** to save the new settings.

Pressing **Previous** twice goes back to the 1.7 level. Pressing **Raise/Scroll** goes to the 1.8 menu level
Pressing **Lower/Scroll** goes to the 1.6 menu level.

Menu 1.8. Menu 1.8 displays weak battery pre-alarm. Pressing **Select/Enter** begins the 1.8.1 level of menus and displays the function activation level. Pressing **Select/Enter** displays the setting. This is not adjustable from the front panel.

Pressing **Previous** goes back to the 1.8.1 level. Pressing **Raise/Scroll** or **Lower/Scroll** begins the 1.8.2 function activation delay level of menus. Pressing **Select/Enter** displays the activation delay time once the level has been exceeded. This is not adjustable from the front panel.

Pressing **Previous** twice goes back to the 1.8 level. Pressing **Raise/Scroll** goes to the 1.9 menu level
Pressing **Lower/Scroll** goes to the 1.7 menu level.

Menu 1.9. Menu 1.9 displays low battery pre-alarm. Pressing **Select/Enter** begins the 1.9.1 level of menus and displays the function activation level. Pressing **Select/Enter** displays the setting. This is not adjustable from the front panel.

Pressing **Previous** goes back to the 1.9.1 level. Pressing **Raise/Scroll** or **Lower/Scroll** begins the 1.9.2 function activation delay level of menus. Pressing **Select/Enter** displays the activation delay time once the level has been exceeded. This is not adjustable from the front panel.

Pressing **Previous** twice goes back to the 1.9 level. Pressing **Raise/Scroll** goes to the 1.10 menu level. Pressing **Lower/Scroll** goes to the 1.8 menu level.

Menu 1.10. Menu 1.10 displays battery over voltage pre-alarm. Pressing **Select/Enter** begins the 1.10.1 level of menus and displays the function activation level. Pressing **Select/Enter** displays the setting. This is not adjustable from the front panel.

Pressing **Previous** goes back to the 1.10.1 level. Pressing **Raise/Scroll** or **Lower/Scroll** begins the 1.10.2 function activation delay level of menus. Pressing **Select/Enter** displays the activation delay time once the level has been exceeded. This is not adjustable from the front panel.

Pressing **Previous** twice goes back to the 1.10 level. Pressing **Raise/Scroll** goes to the 1.11 menu level. Pressing **Lower/Scroll** goes to the 1.9 menu level.

Menu 1.11. Menu 1.11 displays battery charger failure pre-alarm. Pressing **Select/Enter** begins the 1.11.1 level of menus and displays the function activation level. Pressing **Select/Enter** displays the setting. This is not adjustable from the front panel.

Pressing **Previous** goes back to the 1.11.1 level. Pressing **Raise/Scroll** or **Lower/Scroll** begins the 1.11.2 function activation delay level of menus. Pressing **Select/Enter** displays the activation delay time once the level has been exceeded. This is not adjustable from the front panel.

Pressing **Previous** twice goes back to the 1.11 level. Pressing **Raise/Scroll** goes to the 1.12 menu level. Pressing **Lower/Scroll** goes to the 1.10 menu level.

Menu 1.12. Menu 1.12 displays kilowatt overload pre-alarm. Pressing **Select/Enter** begins the 1.12.1 level of menus and displays the function activation level. Pressing **Select/Enter** displays the setting. This is not adjustable from the front panel.

Pressing **Previous** goes back to the 1.12.1 level. Pressing **Raise/Scroll** or **Lower/Scroll** begins the 1.12.2 function activation delay level of menus. Pressing **Select/Enter** displays the activation delay time once the level has been exceeded. This is not adjustable from the front panel.

Pressing **Previous** twice goes back to the 1.12 level. Pressing **Raise/Scroll** goes to the 1.13 menu level. Pressing **Lower/Scroll** goes to the 1.11 menu level.

Menu 1.13. Menu 1.13 displays engine maintenance pre-alarm. Pressing **Select/Enter** begins the 1.13.1 level of menus and displays the function activation level. Pressing **Select/Enter** displays the setting. This is not adjustable from the front panel.

Pressing **Previous** goes back to the 1.13.1 level. Pressing **Raise/Scroll** or **Lower/Scroll** begins the 1.13.2 function activation delay level of menus. Pressing **Select/Enter** displays the activation delay time once the level has been exceeded. This is not adjustable from the front panel.

Pressing **Previous** twice goes back to the 1.13 level. Pressing **Raise/Scroll** goes to the 1.1 menu level. Pressing **Lower/Scroll** goes to the 1.12 menu level.

Pressing **Previous** from any 1.x level menu goes to menu 1. Pressing **Raise/Scroll** goes to menu 2. Pressing **Lower/Scroll** goes to menu 4.

Menu 2. Menu 2 system configuration. Pressing **Select/Enter** from this menu (Figure 3-5) begins the 2.x level of menus. Pressing **Raise/Scroll** and **Lower/Scroll** from this menu scrolls through the 1.x levels of menus.

Menu 2.1. Menu 2.1 displays generator voltage sensing connection. Pressing **Select/Enter** begins the 2.1.1 level and displays the sensing configuration. This is not adjustable from the front panel.

Pressing **Previous** goes back to the 2.1 level. Pressing **Raise/Scroll** goes to menu 2.3. Pressing **Lower/Scroll** goes to the 2.1 menu.

Menu 2.2. Menu 2.2 displays options. Pressing **Select/Enter** (Figure 3-6) begins the 2.2.1 level and displays the speed signal source selection. This is not adjustable from the front panel.

Pressing **Previous** goes back to the 2.2.1 level. Pressing **Raise/Scroll** or **Lower/Scroll** goes to menu 2.2.2 and displays metric conversion.

Pressing **Select/Enter** displays the status of this feature. To change to the metric display press **Raise/Scroll** and enter the user key code followed by the **Select/Enter** key. Press **Raise/Scroll** and then **Select/Enter**. The display will indicate that the new setting has been saved. Press previous twice to go to menu 2.2. Press **Raise/Scroll** to go to menu 2.3. Press **Lower/Scroll** to go to menu 2.1.

Menu 2.3. Menu 2.3 changes user key code. Press **Select/Enter** and then the user key code followed by **Select/Enter** twice. Press the key sequence for the new key code followed by **Select/Enter** twice. The user will be asked to re-enter the new key code followed by **Select/Enter** twice, the display will indicate the new code has been saved.

Pressing **Raise/Scroll** will go to menu 2.4. Pressing **Lower/Scroll** will go menu 2.2.

Menu 2.4. Menu 2.4 pre-alarm audible alarm enable. Pressing **Select/Enter** will display the status of the pre-alarm audible alarm. This feature is not adjustable from the front panel. Pressing **Previous** will go to menu 2.4.

Pressing **Raise/Scroll** will go to menu 2.1. Pressing **Lower/Scroll** will go to menu 2.3.

Pressing **Previous** from any 2.x menu will go to menu 2. Pressing **Raise/Scroll** goes to menu 3. Pressing **Lower/Scroll** goes to menu 1.

Menu 3. Menu 3 sensing devices. Pressing **Select/Enter** (Figure 3-7) begins the 3.1 level of menus

Menu 3.1. Menu 3.1 transformer ratios menu. Menu 3.1.1 (Figure 3-8) displays generator potential transformer primary voltage rating. Pressing **Select/Enter** displays the value. This is not adjustable from the front panel. Pressing **Previous** twice goes to menu 3.1. Pressing **Raise/Scroll** goes to menu 3.1.2. Pressing **Lower/Scroll** goes to menu 3.1.5.

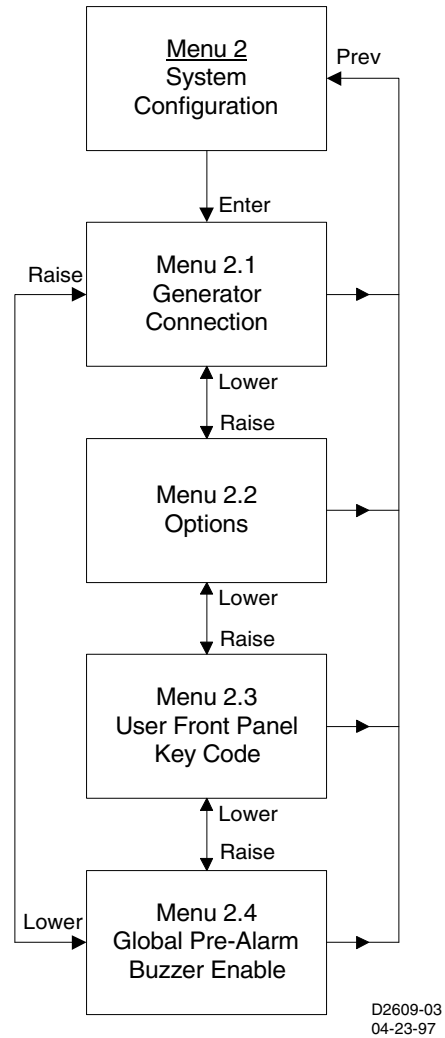

Figure 3-5. Menu 2

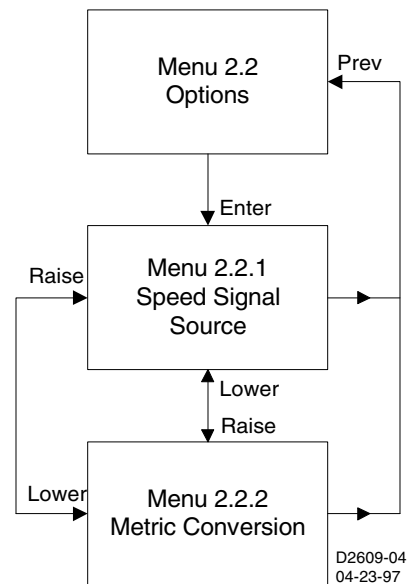

Figure 3-6. Menu 2.2

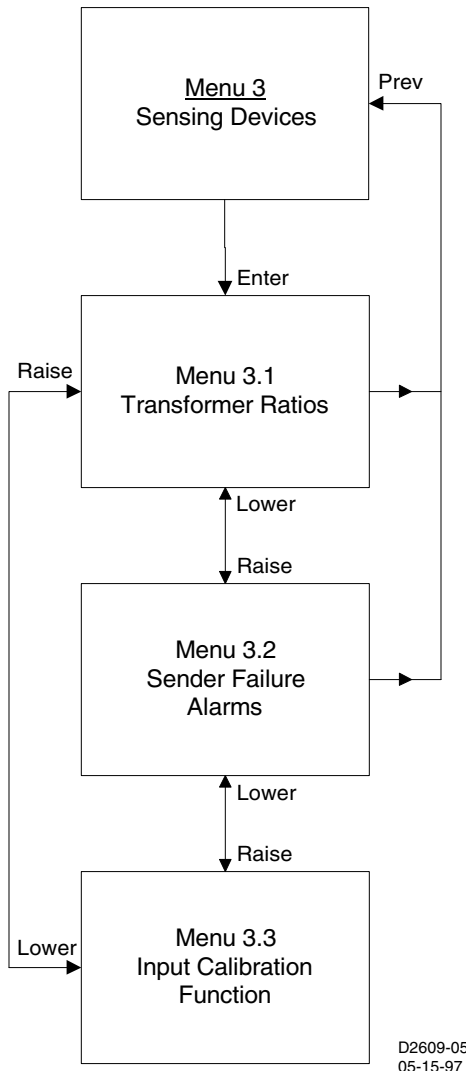

Figure 3-7. Menu 3

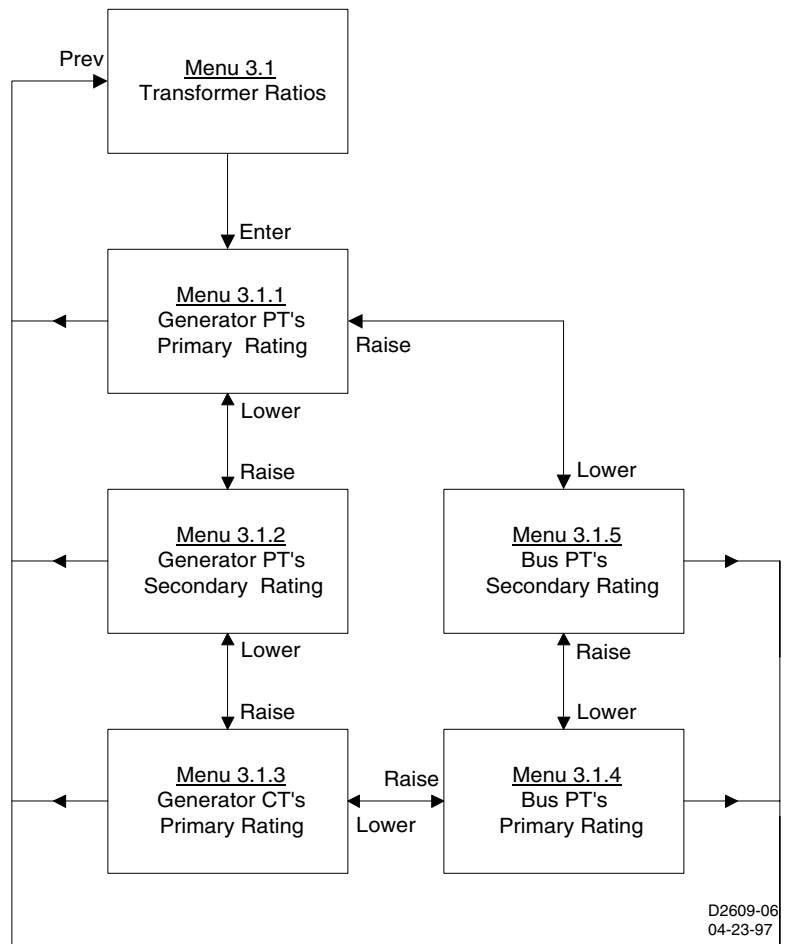

Figure 3-8. Menu 3.1

Menu 3.1.2. Menu 3.1.2 displays the generator potential transformer secondary voltage rating. Pressing **Select/Enter** displays the value. This is not adjustable from the front panel. Pressing previous goes to menu 3.1. Pressing **Raise/Scroll** goes to menu 3.1.3 Pressing **Lower/Scroll** goes to menu 3.1.1.

Menu 3.1.3. Menu 3.1.3 displays the generator current transformer primary current rating. Pressing **Select/Enter** displays the value. This is not adjustable from the front panel. Pressing previous goes to menu 3.1. Pressing **Raise/Scroll** goes to menu 3.1.4. Pressing **Lower/Scroll** goes to menu 3.1.2.

Menu 3.1.4. Menu 3.1.4 displays the bus potential transformer primary voltage rating. Pressing **Select/Enter** displays the value. This is not adjustable from the front panel. Pressing previous goes to menu 3.1. Pressing **Raise/Scroll** goes to menu 3.1.5. Pressing **Lower/Scroll** goes to menu 3.1.3.

Menu 3.1.5. Menu 3.1.5 displays the bus potential transformer secondary voltage rating. Pressing **Select/Enter** displays the value. This is not adjustable from the front panel. Pressing previous goes to menu 3.1. Pressing **Raise/Scroll** goes to menu 3.1.1. Pressing **Lower/Scroll** goes to menu 3.1.4.

Pressing **Raise/Scroll** from menu 3.1 goes to menu 3.2.

Pressing **Previous** goes to menu 3. Pressing **Raise/Scroll** from menu 3 goes to menu 4. Pressing **Lower/Scroll** goes to menu 2.

Menu 4. Menu 4 (Figure 3-10) displays engine parameters and cranking. Pressing **Select/Enter** from menu 4 begins menu 4.1.

Menu 4.1. Menu 4.1 displays cool down time. After pressing **Raise/Scroll** or **Lower/Scroll**, the user will be instructed to enter the user key code. After entering the user key code followed by pressing **Select/Enter** twice, the setting will be adjustable with the **Raise/Scroll** and **Lower/Scroll** keys. After the desired setting has been selected, press **Select/Enter** to save the new setting. Pressing **Previous** goes to menu 4.1. Pressing **Raise/Scroll** goes to menu 4.2. Pressing **Lower/Scroll** goes to menu 4.7.

Menu 4.2. Menu 4.2 displays cranking mode. Pressing **Select/Enter** displays the cranking mode selected. This is not adjustable from the front panel. Pressing **Previous** goes to menu 4.2. Pressing **Raise/Scroll** goes to menu 4.3. Pressing **Lower/Scroll** goes to menu 4.1.

Menu 4.3. Menu 4.3 displays the number of crank cycles. Pressing **Select/Enter** displays the number of crank cycles selected. This is not adjustable from the front panel. Pressing **Previous** goes to menu 4.3. Pressing **Raise/Scroll** goes to menu 4.4. Pressing **Lower/Scroll** goes to menu 4.2.

Menu 4.4. Menu 4.4 displays continuous crank time. Pressing **Select/Enter** displays the continuous crank time selected. This is not adjustable from the front panel. Pressing **Previous** goes to menu 4.4. Pressing **Raise/Scroll** goes to menu 4.5. Pressing **Lower/Scroll** goes to menu 4.3.

Menu 4.5. Menu 4.5 displays cycle crank time. Pressing **Select/Enter** displays the cycle crank time selected. This is not adjustable from the front panel. Pressing **Previous** goes to menu 4.5. Pressing **Raise/Scroll** goes to menu 4.6. Pressing **Lower/Scroll** goes to menu 4.4.

Menu 4.6. Menu 4.6 displays pre-crank delay time. After pressing **Raise/Scroll** or **Lower/Scroll**, the user will be instructed to enter the user key code. After entering the user key code followed by pressing **Select/Enter** twice, the setting will be adjustable with the **Raise/Scroll** and **Lower/Scroll** keys. After the desired setting has been selected press **Select/Enter** to save the new setting. Pressing **Previous** goes to menu 4.6. Pressing **Raise/Scroll** goes to menu 4.7. Pressing **Lower/Scroll** goes to menu 4.5.

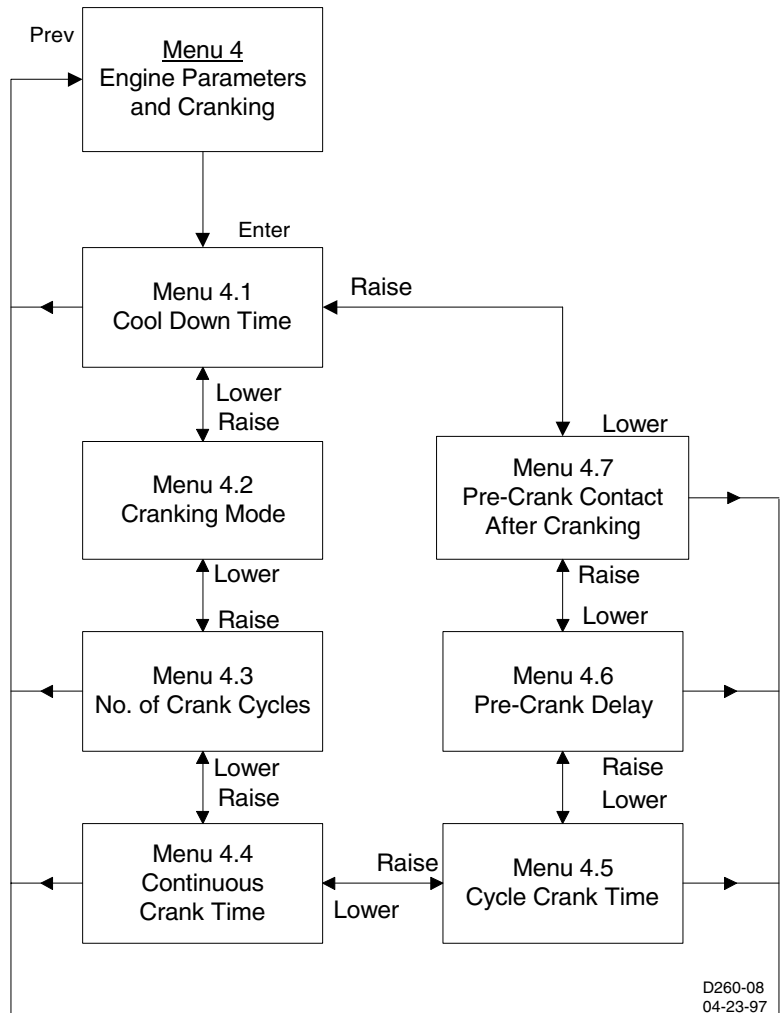

Figure 3-10. Menu 4

Menu 4.7. Menu 4.7 displays the status of the Pre-crank contact after cranking. After pressing **Raise/Scroll** or **Lower/Scroll**, the user will be instructed to enter the user key code. After entering the user key code followed by pressing **Select/Enter** twice, the setting will be adjustable with the **Raise/Scroll** and **Lower/Scroll** keys. After the desired setting has been selected, press **Select/Enter** to save the new setting. Pressing **Previous** goes to menu 4.7. Pressing **Raise/Scroll** goes to menu 4.1. Pressing **Lower/Scroll** goes to menu 4.6.

Pressing **Previous** twice goes to the normal display mode.

Exiting Menu Mode

You may exit Menu mode (from any menu level) by pressing the **Display Toggle** pushbutton. If the **Display Toggle** pushbutton is pressed before a parameter setpoint change has been saved, then the old setpoint value is preserved.

NOTE

Using DISPLAY TOGGLE to exit Menu mode will save the user's place within the menu system so that the next time Menu mode is entered, the display will return to the same screen.

As an alternative, pressing **Previous** allows the user to back out of the menu mode one level at a time so that the next time menu mode is entered, the display will start at the top of the menu structure.

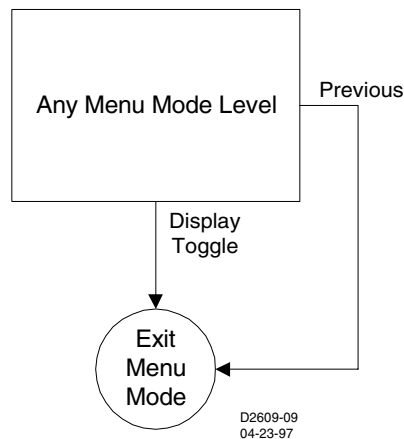

Figure 3-11. Exiting Menu Mode

Modifying Setpoints

To modify an existing setpoint, press the **Select/Enter** pushbutton (Figure 3-12). Press **Raise/Scroll** or **Lower/Scroll** buttons to raise or lower the current parameter setpoint. Press the **Select/Enter** pushbutton to save the modified setpoint value, or press the **Previous** pushbutton to exit the parameter setting screen without changing the value.

Once in the menu mode, the first time an attempt is made to change a setting that is front panel adjustable, the user will be prompted to enter the key code. Upon successful entry of the key code, the user may modify any of the adjustable settings without re-entering the key code during the current menu mode session. The only exception to this is changing the key code itself. Changing the key code always requires entry of the existing key code. Also, whether the key code is actually changed or not, any further changes to other settings after that will require the key code to be entered once again. Leaving the Menu mode after an editing session automatically terminates the editing privilege.

Press the **Display Toggle** pushbutton to exit the menu mode.

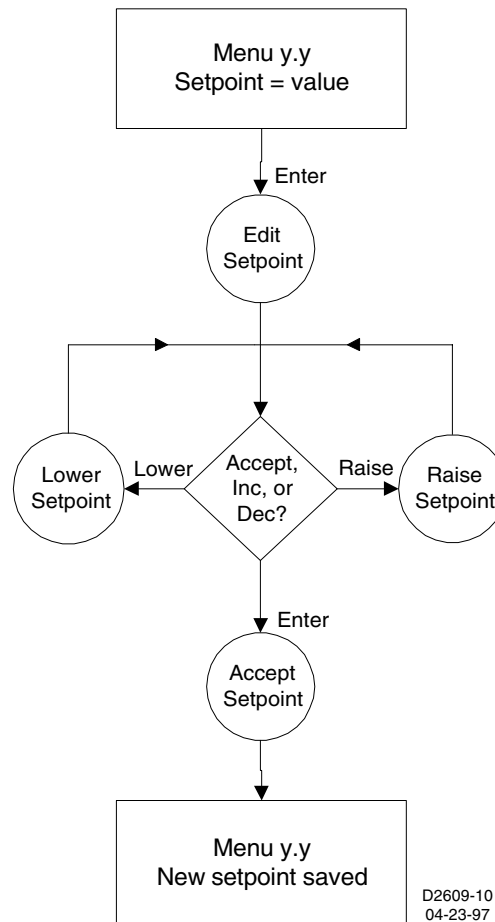

Figure 3-12. Modifying Setpoints

Alternate Display Mode

After pressing the **Display/Toggle** pushbutton to enter the alternate display mode, pressing the **Raise/Scroll** or **Lower/Scroll** pushbutton allows the user to scroll through the alternate display mode screens.

The quantities are displayed in the following order.

- OIL PRESSURE
- COOLANT TEMPERATURE
- FUEL LEVEL
- BATTERY VOLTAGE
- TOTAL KILOWATT LOAD
- HOURS TO NEXT SERVICE
- GENERATOR A-B VOLTAGE
- GENERATOR B-C VOLTAGE (3-PHASE SENSING ONLY)
- GENERATOR C-A VOLTAGE (3-PHASE SENSING ONLY)
- GENERATOR A-N VOLTAGE (3-PHASE L-N SENSING)
- GENERATOR B-N VOLTAGE (3-PHASE L-N SENSING)
- GENERATOR C-N VOLTAGE (3-PHASE L-N SENSING)
- BUS VOLTAGE
- GENERATOR PHASE A CURRENT (3-PHASE SENSING ONLY)
- GENERATOR PHASE B CURRENT (3-PHASE SENSING ONLY)
- GENERATOR PHASE C CURRENT (3-PHASE SENSING ONLY)
- PHASE A kVA (3-PHASE SENSING ONLY)
- PHASE B kVA (3-PHASE SENSING ONLY)
- PHASE C kVA (3-PHASE SENSING ONLY)
- TOTAL kVA
- GENERATOR PHASE A KILOWATTS (3-PHASE SENSING ONLY)
- GENERATOR PHASE B KILOWATTS (3-PHASE SENSING ONLY)
- GENERATOR PHASE C KILOWATTS (3-PHASE SENSING ONLY)
- GENERATOR TOTAL KILOWATT-HOURS
- GENERATOR POWER FACTOR
- GENERATOR FREQUENCY
- BUS FREQUENCY
- TOTAL RUN HOURS
- AIR BOX DAMPER STATUS
- ENGINE SPEED

FACTORY KEY CODE SETTING

Factory preprogrammed key code setting.

1. Raise/Scroll
2. Lower/Scroll
3. Select/Enter
4. Previous
5. Display Toggle
6. Enter
7. Enter

ALLOWABLE KEY CODE PUSHBUTTONS

User key codes are one to eight presses of any of the following acceptable pushbuttons in any order, except **Previous** twice consecutively. When used, the key code must be followed by two presses of the Select/Enter pushbutton.

- Raise/Scroll
- Lower/Scroll
- Select/Enter
- Previous
- Display/Toggle
- Phase Toggle
- Alarm Silence
- Lamp Test

PARAMETERS AND DEFAULT SETTINGS

Front Panel Adjustable Parameters

All settings are viewable at the front panel. The following settings are adjustable at the front panel.

- Sensor failure alarm time delay From 1 to 10 seconds in 1 second increments
- Metric conversion function ON or OFF
- Low fuel pre-alarm level 10 to 100%
- Pre-crank contact after cranking OPEN or CLOSED
- Cool down time From 0 to 60 minutes in 5 minute increments
- Pre-crank time delay From 0 to 30 seconds in 1 second increments

All Parameters

Specific parameters (settings) are not adjustable at either the front panel or through computer communications. These settings are identified in the following list as (not adjustable). All other parameters may be set through computer communications. Only those settings identified in the previous paragraph are adjustable at the front panel. The following list provides the parameters and the default setting.

Metric Conversion (ON, OFF) default is OFF

Generator Connection (3-phase_{L-L} or 3-phase_{L-N}, 1-phase_{A-B}) default is 3-phase_{L-N}

Gen. PT Primary (1 - 15000 V) default is 480 V

Gen. PT Secondary (1 - 480 V) default is 480 V

Gen. CT Primary (1 - 5000 A) default is 500 A

Bus. PT Primary (1 - 15000 V) default is 480 V

Bus. PT Secondary (1 - 480 V) default is 480 V

Cooldown time (0 - 60 minutes) default is 0 minutes

Generator Speed Signal Sources = MPU/Alt/Gen

Overspeed Alarm:

 Threshold (105 - 140%) default is 110%

 Activation Delay (10 - 500 milliseconds) default is 50 milliseconds

High Coolant Temperature Alarm:

 Threshold (100 - 280°F) default is 275°F

 Arming Delay (not adjustable) is 60 seconds

High Coolant Temperature Pre-alarm is OFF:

 Threshold (100 - 280°F) default is 250°F

 Arming Delay default is 60 seconds

Low Oil Pressure Alarm:

 Threshold (3 - 100 PSI) default is 15 PSI

 Arming Delay (5 - 15 seconds) default is 10 seconds

Low Oil Pressure Pre-alarm:
Threshold (3 - 100 PSI) default is 25 PSI
Arming Delay (5 - 15 seconds) default is 10 seconds

Low Coolant Temperature Pre-alarm is OFF:
Threshold (40 - 100 F) default is 50 F
Arming Delay (0 - 15 seconds) default is 0 seconds

Low Fuel Level Pre-alarm is OFF:
Threshold (10 - 100 %) default is 25 %
Activation Delay (not adjustable) is 0 seconds

Weak Battery Pre-alarm is OFF:
Threshold (4 - 8/8 - 16 V) default is 7.2/15.0 V (for 12/24 V systems)
Activation Delay (1 - 10 seconds) default is 2 seconds

Low Battery Pre-alarm is OFF:
Threshold (6 - 12/12 - 24 V) default is 9.0/20.0 V (for 12/24 V systems)
Activation Delay (1 - 10 seconds) default is 10 seconds

Battery Overvoltage Pre-alarm is OFF:
Threshold (14 - 16/24-32 V) default is 15.0/30.0 V (for 12/24 V systems)
Activation Delay (not adjustable) is 0 seconds

Battery Charger Failure Pre-alarm is OFF:
Activation Delay (not adjustable) is 0 seconds

Global Sender Failure Alarm Delay (1 - 10 seconds) default is 10 seconds:
(This covers the oil pressure sender, generator sensing voltage, and speed signal sources)

Speed Signal Failure Alarm (ON, OFF) default is OFF.
Oil Pressure Sender Failure Alarm (ON, OFF) default is OFF.
Generator Sensing Voltage Failure Alarm (ON, OFF) default is OFF.
Coolant Temperature Sender Failure Alarm (ON, OFF) default is OFF.
Arming Delay (5 - 30 minutes) default is 5 minutes

(Global) Pre-alarm Buzzer default is ON.

Maintenance Interval Pre-alarm:
Threshold (0 - 5000 hours) default is 500 hours
Activation Delay (not adjustable) is 0 hours

Engine KW Overload Pre-alarm is OFF:
Threshold (95 - 140%) default is 105%
Activation Delay (not adjustable) is 0 seconds

Cranking style (CONTINUOUS/CYCLE) is CYCLE
crank cycles (1 - 7 cycles) default is 2 cycles
Cycle crank time (5 - 15 seconds) default is 5 seconds
Continuous crank time (1 - 60 seconds) default is 10 seconds
Pre-crank delay (0 - 30 seconds) default is 0 seconds
Pre-start contact after crank disconnect is OFF (OPEN)

SECTION 4 • INSTALLATION

GENERAL

DGC-2000 Digital Generator Controllers are delivered in sturdy cartons to prevent shipping damages. Upon receipt of the unit, check for damage, and if there is evidence of such, immediately file a claim with the carrier and notify the Basler Electric Regional Sales Office, your sales representative or a sales representative at Basler Electric, Highland, Illinois.

If the controller is not installed immediately, store it in the original shipping package in a moisture and dust free environment.

HARDWARE

DGC-2000 Controllers are packaged in aluminum cases for improved electromagnetic compatibility and are suitable for mounting in any top mount enclosure. The metal case is resistant to moisture, salt fog, humidity, dust, dirt, and chemical contaminants. It also inhibits insect and rodent entrance. DGC-2000 Controllers are mounted using the permanently attached 10-32 by 5/8 inch (1/2 inch usable) studs.

MOUNTING

Case cutout dimensions are shown in Figure 4-1. Overall dimensions are shown in Figures 4-2 and 4-3.

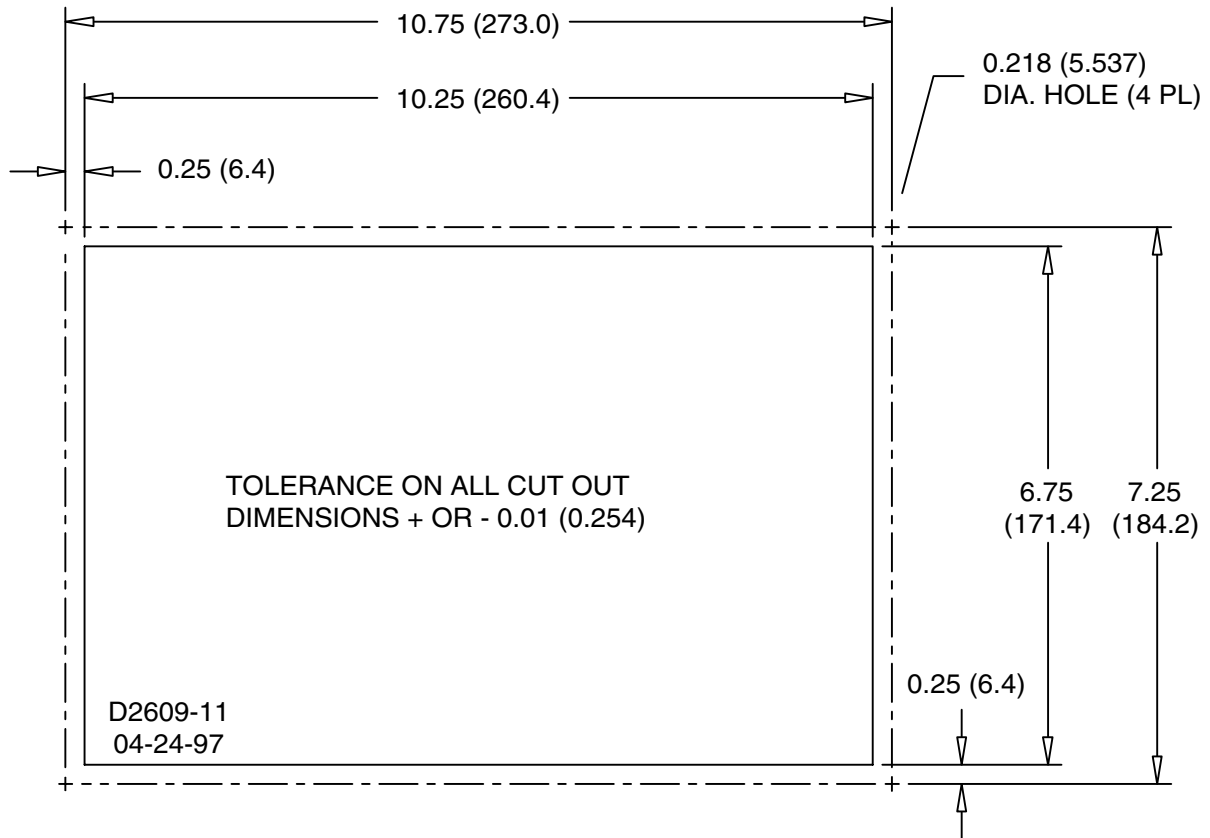

Figure 4-1. Cutout Dimensions In Inches (Millimeters)

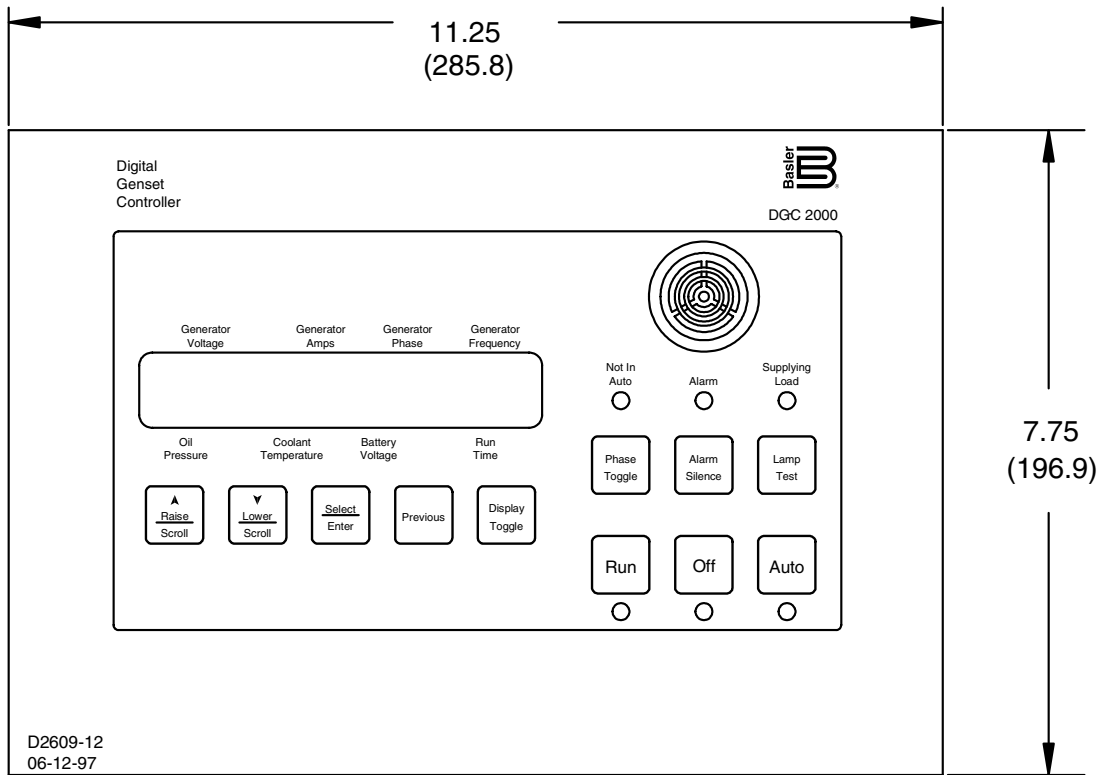
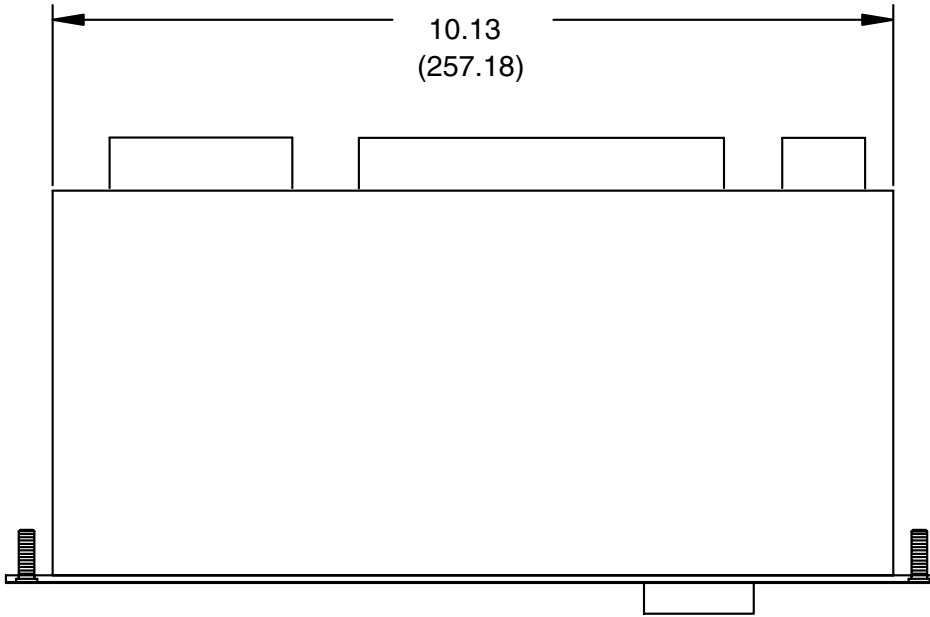

Figure 4-2. DGC-2000 Overall Dimensions In Inches (Millimeters)

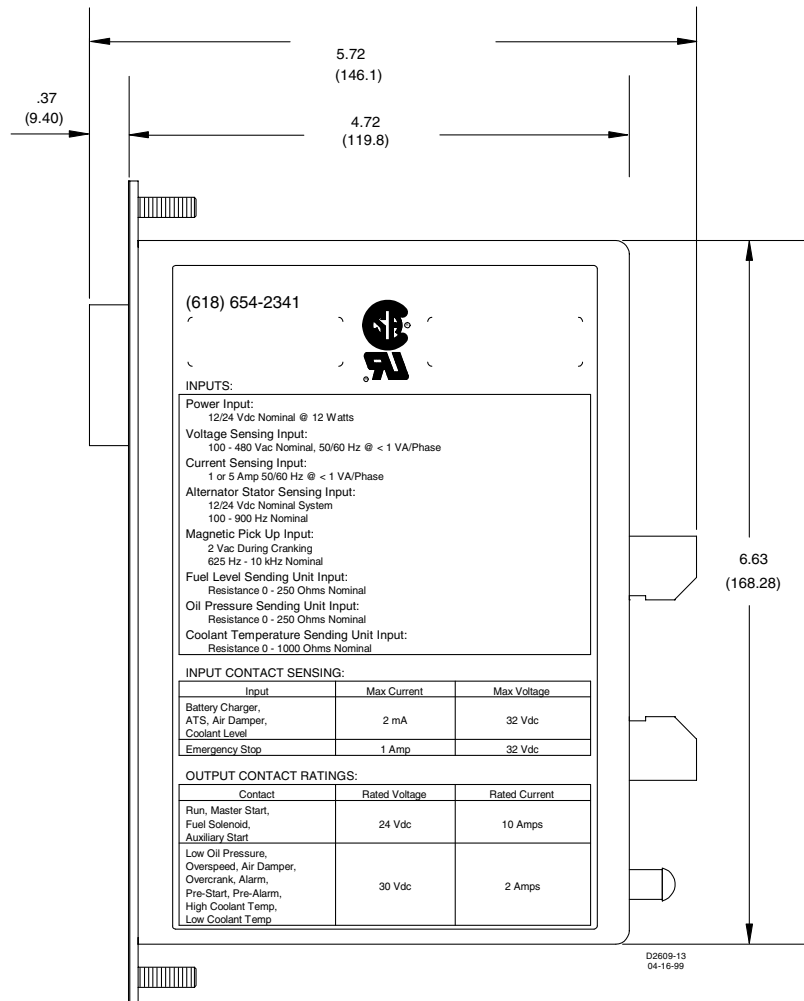

Figure 4-3. DGC-2000 Overall Dimensions In Inches (Millimeters)

CONNECTIONS

Incorrect wiring may result in damage to the controller.

WARNING!

If the air damper is functional, an auxiliary contact from the Emergency Stop switch must be used to trip the air damper solenoid.

CAUTION

Be sure the controller battery input polarity is wired correctly. Reverse polarity battery power will damage the controller.

NOTE

Be sure the controller is hard-wired to earth ground with no smaller than 12 AWG copper wire attached to the ground terminal on the rear of the controller case

Except as noted above, connections should be made with minimum wire size of 14 AWG. Be sure to use the correct input power for the power supply. Figure 4-4 is a typical ac connection diagram for direct connected single-phase sensing system. Figure 4-5 is a typical ac connection diagram for direct connected three-phase line to line sensing system. Figure 4-6 is a typical ac connection diagram for direct connected three-phase line to neutral sensing system.

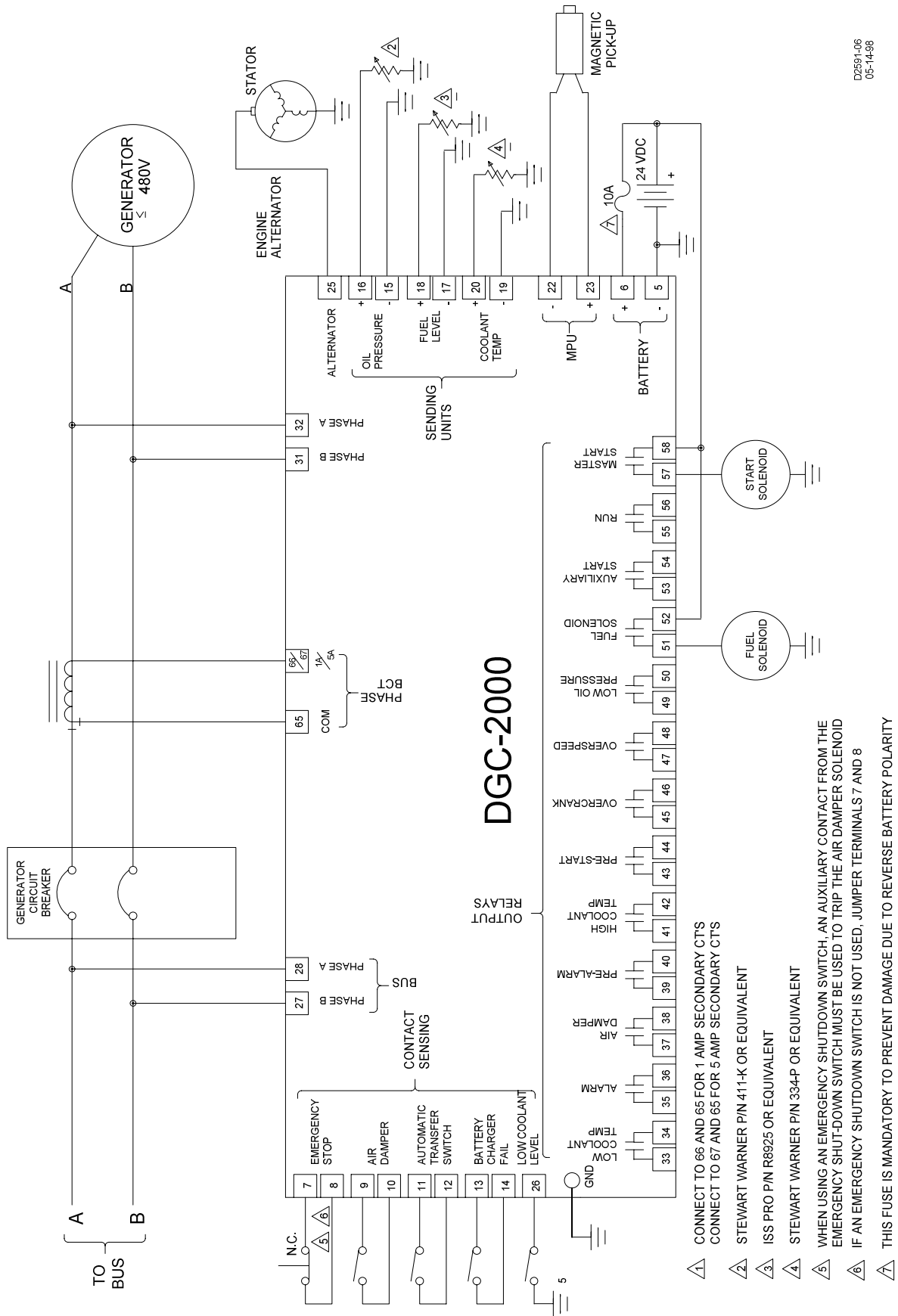
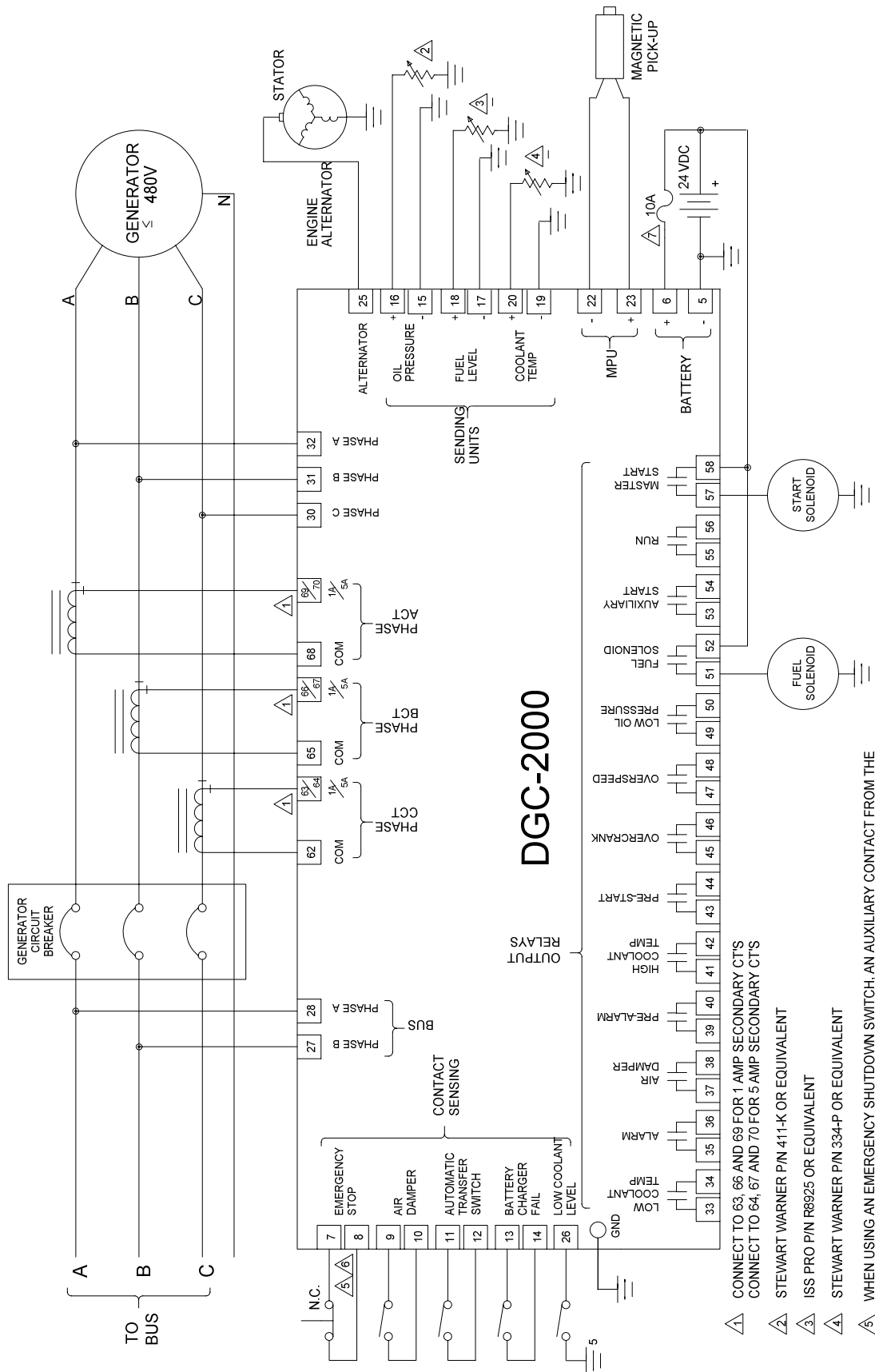
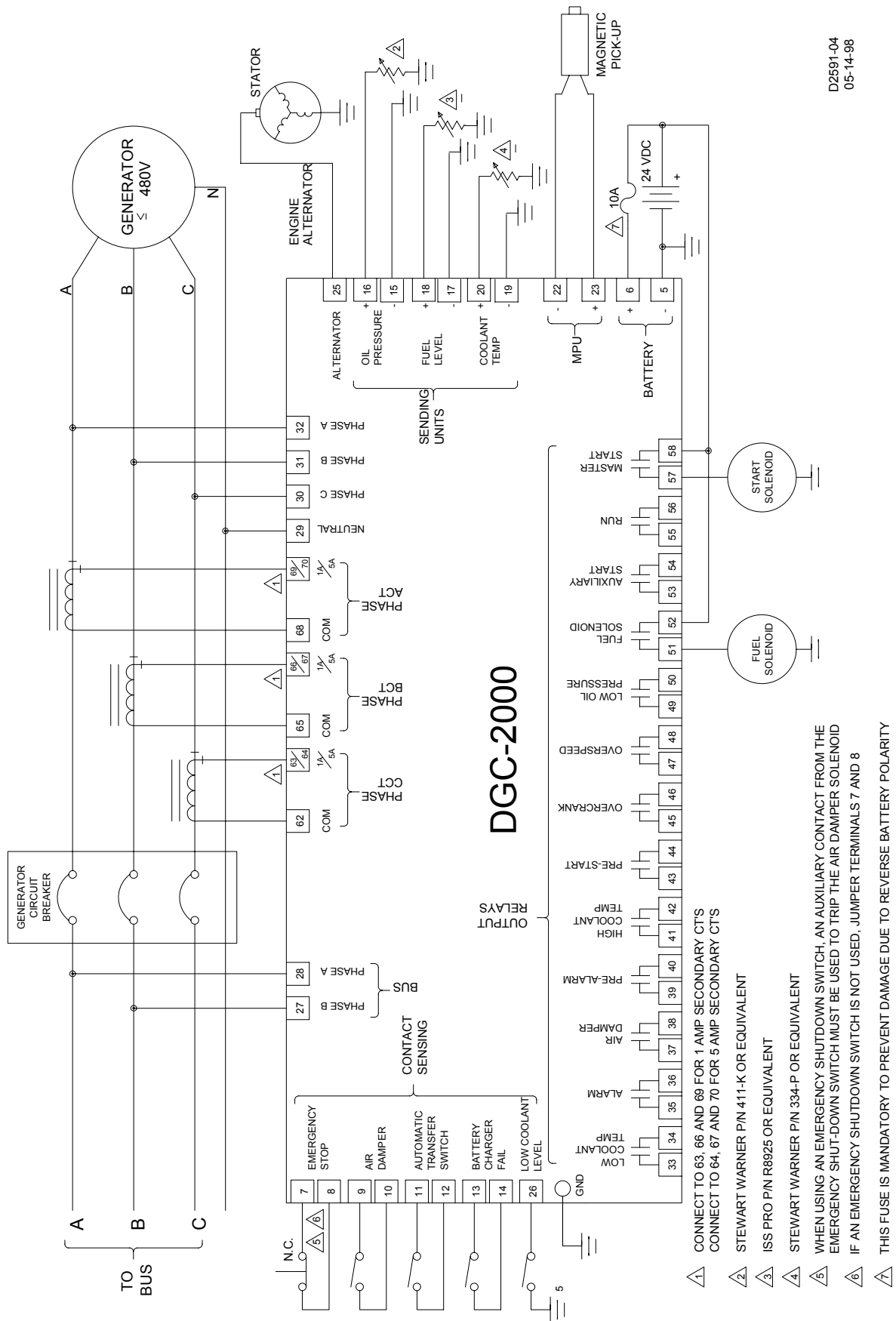

Figure 4-4. DGC-2000 Direct Connected Single-Phase Sensing



D2591-05
05-14-98

Figure 4-5. DGC-2000 Direct Connected Three-Phase Line To Line Sensing



D2591-04
05-14-98

Figure 4-6. DGC-2000 Direct Connected Three-Phase Line To Neutral Sensing

COMMUNICATION CONNECTORS AND SETTINGS

RS-232 Connector

The RS-232 connector is a DB-9 female connector. Connector pin numbers, functions, names, and signal directions are shown in Table 4-1. Figure 4-7 provides the RS-232 cable connection diagram.

Table 4-1. RS-232 Pin Assignments

Pin	Function	Name	Direction
1	N/C	----	N/A
2	Transmit Data	(TXD)	From DGC-2000
3	Receive Data	(RXD)	Into DGC-2000
4	N/C	----	N/A
5	Signal Ground	(GND)	N/A
6	N/C	----	N/A
7	N/C	----	N/A
8	N/C	----	N/A
9	N/C	----	N/A

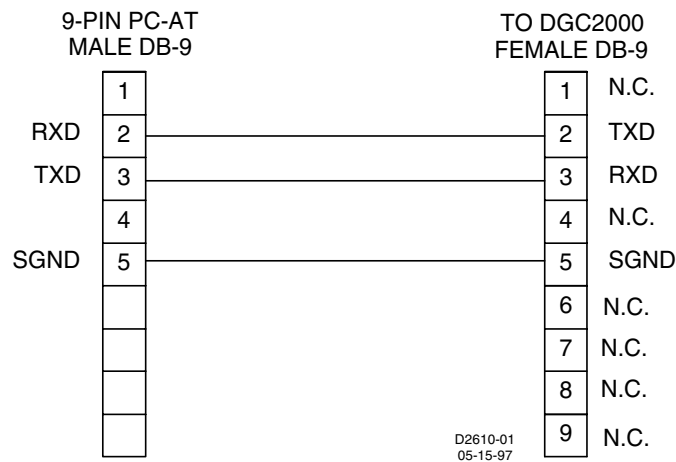

Figure 4-7. Personal Computer To DGC-2000

Communication Settings

Communication settings are the formal set of conventions controlling the format and relative timing of message exchange between two communications terminals. Default settings baud rate = 9600, parity = None, and stop bits = 1.

This page intentionally left blank.

SECTION 5 • TESTING

INTRODUCTION

This section provides a procedure for testing the DGC-2000 using the preset factory default settings. Testing accuracies are based on the entire operating temperature range.

EQUIPMENT REQUIRED

- DC Power Supply, 24 Volts
- 10 Amp Fuse
- Voltage Source, 60 hertz, 0 to 120V
- Current Source, 60 hertz, 0 to 5A
- Signal Generator, Sine Wave, 0 to 5k hertz, 0 to 5V
- Digital Voltmeter, 4 1/2 Digits (Fluke 8050A or Equivalent)
- Continuity Tester
- Four Single-Pole Switches
- 2 each, 250 ohm variable resistors
- 1 each 2500 ohm variable resistor

INITIAL TEST PROCEDURE

Unless otherwise specified, the test procedures in this manual use the default parameter settings provided in Table 5-1.

Table 5-1. Default Parameter Settings

PARAMETER	SETTING
Comm Baud Rate	9600 Baud
Remote Delay Time	1 Millisecond/10
Comm Parity	None
Device Address	125
Modem Time Delay	9000 Microseconds
Embedded Code Version No.	Ver. No.
Settings Source	User
Generator Connection	3-ph L-N
NFPA Level	0
Unit System	English
Battery Volts	24 Volts
Generator Frequency	60 Hz
Rated Engine RPM	1800 RPM
Number Flywheel Teeth	126
Genset KW Rating	300 kilowatt
No Load Cool Down Time	0 Minutes
Alternator Frequency Rated	600 Hertz
Generator PT Primary Voltage	480 Vac
Generator PT Secondary Voltage	480 Vac
Generator CT Primary Current	500 Aac
Bus PT Primary Voltage	480 Vac
Bus PT Secondary Voltage	480 Vac
Low Fuel Pre-Alarm Enable	OFF
Low Fuel Pre-Alarm Threshold	25% Full Tank

PARAMETER	SETTING
Low Coolant Temperature Pre-Alarm Enable	OFF
Low Coolant Temperature Pre-Alarm Threshold	50 Degrees F
Battery Overvoltage Pre-Alarm Enable	OFF
Battery Overvoltage Pre-Alarm Threshold	30.0 VDC
Maintenance Interval Pre-Alarm Enable	OFF
Maintenance Interval Pre-Alarm Threshold	500 Hours
Engine KW Overload Pre-Alarm Enable	OFF
Engine KW Overload Pre-Alarm Threshold	105 % of Rated
High Coolant Temperature Pre-Alarm Enable	ON
High Coolant Temperature Pre-Alarm Threshold	250 Degrees F
Low Oil Pressure Pre-Alarm Enable	ON
Low Oil Pressure Pre-Alarm Threshold	25 PSI
Low Battery Voltage Pre-Alarm Enable	OFF
Low Battery Voltage Pre-Alarm Threshold	20.0 VDC
Low Battery Voltage Pre-Alarm Activation Time Delay	10 Seconds
Weak Battery Pre-Alarm Enable	OFF
Weak Battery Pre-Alarm Threshold	15.0 VDC
Weak Battery Pre-Alarm Activation Time Delay	2 Seconds
High Coolant Temperature Alarm Enable	ON
High Coolant Temperature Alarm Threshold	275 Degrees F
High Coolant Temperature Alarm Arming Delay After Crank Disconnect	60 Seconds
Low Oil Pressure Alarm Enable	ON
Low Oil Pressure Alarm Threshold	15 PSI
Low Oil Pressure Alarm Arming Delay After Crank Disconnect	10 Seconds
Overspeed Alarm Enable	ON
Overspeed Alarm Threshold	110% of Rated
Overspeed Alarm Activation Time Delay	50 Millisecond
Coolant Temperature Sender Failure Alarm Enable	OFF
Oil Pressure Sender Failure Alarm Enable	OFF
Speed Failure Alarm Enable	OFF
Loss of Generator Voltage Alarm Enable	OFF
Pre-Alarm Buzzer Enable	ON
Battery Charger Failure Pre-Alarm Enable	OFF
Global Sender Failure Alarm Time Delay	10 Seconds
Coolant Temp. Sender Failure Alarm Activation Time Delay	5 Minutes
Cranking Style	Cycle
Number of Crank Cycles	2
Cycle Crank Time	5 Seconds
Continuous Crank Time	10 Seconds
Crank Disconnect Limit	30 % of Rated
Pre-Crank Delay	0 Seconds
Pre-crank Contact After Crank Disconnect	Open
Generator Speed Mode	MPU/ALT/GEN
Generator Rotation	A-B-C

- Step 1. Connect the DGC-2000 test setup as shown in Figure 5-1.
- Step 2. Apply operating voltage to battery voltage terminals.
Result: The LCD displays DGC 2000 and the software version for approximately one second before switching to the normal display mode and at the same time, the Alarm sounds. The audible alarm will sound continuously when Not In Auto or in Alarm. The audible alarm may be silenced by pressing the Alarm Silence switch on the front panel.
- Step 3. Press the Off switch to place the DGC-2000 in the OFF position.
- Step 4. Verify that LEDs Not In Auto and Off are ON, the Alarm LED is flashing, and the LCD backlight is ON with system parameters displayed.
- Step 5. Press the Lamp Test switch and verify that all six LEDs are ON (Not In Auto, Alarm, and Off are red; Supplying Load, Run, and Auto are green). All LCD pixels should be visible.
- Step 6. Verify Run, Off, and Auto switches, along with their respective LEDs, toggle as each switch is operated. Not In Auto LED should be OFF when Auto is selected.
- Step 7. Verify that switches Raise/Scroll, Lower/Scroll, Select/Enter, Previous, and Display/Toggle are functional by scrolling through the unit menus.

METERING TEST PROCEDURES

Metering Battery And Generator Voltages

NOTE

Displayed voltage is equal to the generator potential transformer primary voltage setting times the applied voltage divided by the generator potential transformer secondary voltage setting.

- Step 1. Verify that the battery input (terminals 5 and 6) voltage is 24.0 Vdc.
- Step 2. Verify that the DGC-2000 displayed value is 24.0 \pm 0.5 Vdc.
- Step 3. Apply 120.0 Vac, 60.0 hertz to phase A (line to neutral) generator voltage input (terminals 32 and 29).
- Step 4. Verify that the DGC-2000 generator frequency displayed value is 60.0 \pm 0.2 hertz.
- Step 5. Verify that the DGC-2000 phase A to neutral voltage displayed value is 120.0 \pm 2.0 Vac.
- Step 6. Remove the voltage.
- Step 7. Apply 120.0 Vac, 60.0 hertz to phases A and B generator voltage input (terminals 32 and 31).
- Step 8. Verify that the DGC-2000 generator A to B voltage displayed value is 120.0 \pm 2.0 Vac.
- Step 9. Remove the voltage.
- Step 10. Apply 120.0 Vac, 60.0 hertz (line to neutral) to phase B generator voltage input (terminals 31 and 29).
- Step 11. Verify that the DGC-2000 line to neutral voltage displayed value is 120.0 \pm 2.0 Vac.
- Step 12. Remove the voltage.
- Step 13. Apply 120.0 Vac, 60.0 hertz to phases B and C generator voltage input (terminals 31 and 30).
- Step 14. Verify that the DGC-2000 generator B to C voltage displayed value is 120.0 \pm 2.0 Vac.
- Step 15. Remove the voltage.
- Step 16. Apply 120.0 Vac, 60.0 hertz (line to neutral) to phase C generator voltage input (terminals 30 and 29).
- Step 17. Verify that the DGC-2000 line to neutral voltage displayed value is 120.0 \pm 2.0 Vac.
- Step 18. Remove the voltage.
- Step 19. Apply 120.0 Vac, 60.0 hertz to phases C and A generator voltage input (terminals 30 and 32).
- Step 20. Verify that the DGC-2000 generator C to A voltage displayed value is 120.0 \pm 2.0 Vac.
- Step 21. Remove the voltage.

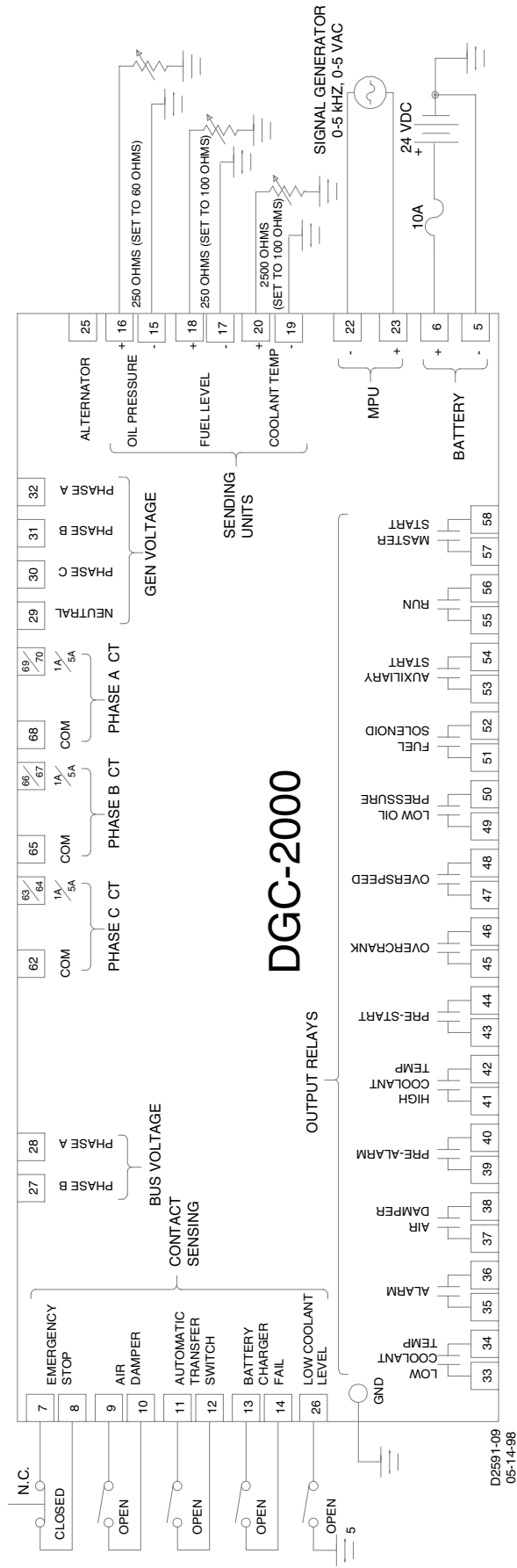

D2591-09
05-14-98

Figure 5-1. Test Set Diagram

Metering Bus Voltages

NOTE

Displayed voltage is equal to the bus potential transformer primary voltage setting times the applied voltage divided by the bus potential transformer secondary voltage setting.

- Step 1. Apply 120.0 Vac, 60.0 hertz to phases A and B bus voltage input (terminals 28 and 27).
- Step 2. Verify that the DGC-2000 bus A and B frequency displayed value is 60.0 \pm 0.2 hertz.
- Step 3. Verify that the DGC-2000 bus A and B voltage displayed value is 120.0 \pm 2.0 Vac.
- Step 4. Remove the voltage.

Metering Generator Current

NOTE

Displayed current is equal to the generator current transformer primary current setting times the applied current divided by one or five (the nominal current value).

- Step 1. Apply 1.000 Aac to the DGC-2000 generator five ampere phase A CT input (terminals 70 and 68).
- Step 2. Verify that the DGC-2000 phase A current displayed value is 100.0 \pm 2.0 amperes.
- Step 3. Remove the current.
- Step 4. Apply 1.000 Aac to the DGC-2000 generator five ampere phase B CT input (terminals 67 and 65).
- Step 5. Verify that the DGC-2000 phase B current displayed value is 100.0 \pm 2.0 amperes.
- Step 6. Remove the current.
- Step 7. Apply 1.000 Aac to the DGC-2000 generator five ampere phase C CT input (terminals 64 and 62).
- Step 8. Verify that the DGC-2000 phase C current displayed value is 100.0 \pm 2.0 amperes.
- Step 9. Remove the current.

Oil Pressure

- Step 1. Apply 60 ohms across the Oil Pressure sender input (terminals 16 and 5).
- Step 2. Verify that the DGC-2000 displayed value is 80 \pm 2.0 PSI.

Coolant Temperature

- Step 1. Apply 100 ohms across the Coolant Temperature sender input (terminals 20 and 5).
- Step 2. Verify that the DGC-2000 displayed value is 205 \pm 4.0° C.

Percent Fuel Level

- Step 1. Apply 130 ohms across the Fuel Level sender input (terminals 18 and 5).
- Step 2. Verify that the DGC-2000 displayed value is 50 \pm 2.0%.

Engine Speed (RPM)

NOTE

RPM as derived from the MPU is equal to [MPU output frequency (hertz) times 60] divided by the number of flywheel teeth.

RPM as derived from the alternator is equal to [alternator output frequency (hertz) times rated RPM] divided by the rated alternator frequency (hertz).

RPM as derived from the generator is equal to [generator output voltage frequency (phase A to neutral in hertz)] divided by the rated generator frequency (hertz).

- Step 1. Apply a 5 Vac, 3780 hertz sine wave to the DGC-2000 magnetic pickup unit inputs (terminals 23 and 22).
- Step 2. Verify that the DGC-2000 displayed value is 1800 \pm 36 RPM.
- Step 3. Remove the voltage.

Generator Power Factor

NOTE

The DGC-2000 uses phase A voltage and phase B current for Power Factor calculations. Therefore, if this test is performed with the current lagging the voltage by 120 degrees., the displayed Power Factor will be approximately 1.00.

- Step 1. Apply 120 Vac to phase A to neutral generator voltage inputs (terminals 32 and 29).
- Step 2. Apply 1.0 Aac to phase B current transformer inputs (terminals 67 and 65) in phase with the phase A to neutral voltage.
- Step 3. Verify that the DGC-2000 displayed value is -0.50 \pm 0.02.
- Step 4. Remove voltage and current.

Generator kW And kVA

NOTE

The displayed kW is equal to the kVA times the Power Factor.

- Step 1. Apply in parallel 120 Vac to phase A to neutral (terminals 32 and 29), phase B to neutral (terminals 31 and 29), and phase C to neutral (terminals 30 and 29).
- Step 2. Apply in series and in phase with the voltage 1 Aac to Phase A current transformer input (terminals 69 and 68), Phase B current transformer input (terminals 66 and 65), and Phase C current transformer input (terminals 63 and 62).
- Step 3. Verify that the DGC-2000 displayed value for individual phase kW is -30 \pm 2 kW.
- Step 4. Verify that the DGC-2000 displayed value for total kW is -90 \pm 2 kW.
- Step 5. Verify that the DGC-2000 displayed value for individual phase kVA is 60 \pm 2 kVA.
- Step 6. Verify that the DGC-2000 displayed value for total kVA is within 180 \pm 5 kVA.
- Step 7. Remove voltage and current.

CRANKING TEST PROCEDURES

Crank Cycle

NOTE

The DGC will go into Overcrank if the Off switch is not pressed before two crank cycles expire. Pressing Off will reset this condition if it occurs.

- Step 1. Verify that all output contacts are open.
- Step 2. Press the Run switch on the front panel.
- Step 3. Verify that the DGC-2000 displays CRANKING STATUS.
- Step 4. Verify that only the Master Start, Auxiliary Start, Fuel Solenoid, and Pre-Start output contacts are closed during CRANKING CYCLE.
- Step 5. Verify that only the Pre-Start contact remains closed during RESTING.
- Step 6. Press the Off switch on the front panel.
- Step 7. Press the Auto switch on the front panel.
- Step 8. Apply a contact closure across the Automatic Transfer Switch inputs (terminals 11 and 12).
- Step 9. Verify that the DGC-2000 displays CRANKING STATUS.
- Step 10. Verify that only the Master Start, Auxiliary Start, Fuel Solenoid, and Pre-Start output contacts are closed during CRANKING CYCLE.

Step 11. Verify that only the Pre-Start contact remains closed during RESTING.

Step 12. Press the Off switch on the front panel.

Step 13. Open the contact across the Automatic Transfer Switch inputs.

Running

Step 1. Press the Run switch on the front panel.

Step 2. Within 5 seconds of beginning cranking, apply in parallel 120 Vac to phase A to neutral (terminals 32 and 29), phase B to neutral (terminals 31 and 29), and phase C to neutral (terminals 30 and 29).

Step 3. Verify that only the Run and Fuel Solenoid output contacts are closed.

Step 4. Verify that the DGC-2000 normal mode display now meters the active generator values listed on the front panel instead of displaying READY.

Step 5. Press the Off switch on the front panel.

Step 6. Remove the voltage.

Step 7. Press the Auto switch on the front panel.

Step 8. Apply a contact closure across the Automatic Transfer Switch inputs (terminals 11 and 12).

Step 9. Within 5 seconds of beginning cranking, apply in parallel 120 Vac to phase A to neutral (terminals 32 and 29), phase B to neutral (terminals 31 and 29), and phase C to neutral (terminals 30 and 29).

Step 10. Verify that only the Run and Fuel Solenoid output contacts are closed.

Step 11. Verify that the DGC-2000 normal mode display now meters the active generator values listed on the front panel instead of displaying READY.

Step 12. Press the Off switch on the front panel.

Step 13. Remove the voltage.

Step 14. Open the contact across the Automatic Transfer Switch inputs.

PROTECTIVE FUNCTIONS

Overcrank

Step 1. Press the Run switch on the front panel.

Step 2. Verify that after two cycles the DGC-2000 display indicates GEN OVER-CRANK ALARM and that only the Alarm, Air Damper, and Overcrank output contacts are closed.

Step 3. Press the Off switch on the front panel and verify that the DGC-2000 resets to the Ready mode and that all output contacts open.

Overspeed

Step 1. Apply in parallel 120 Vac to phase A to neutral (terminals 32 and 29), phase B to neutral (terminals 31 and 29), and phase C to neutral (terminals 30 and 29).

Step 2. Apply a 5 Vac, 4000 hertz sine wave to the DGC-2000 MPU inputs (terminals 23 and 22).

Step 3. Press the Run switch on the front panel.

Step 4. Slowly increase the frequency to the DGC-2000 MPU input until an overspeed shutdown occurs.

Step 5. Verify shutdown occurs within 4158 ± 83 hertz (1980 ± 38 RPM).

Step 6. Verify that the DGC-2000 display indicates GEN OVERSPEED ALARM and that only the Alarm, Air Damper, and Overspeed output contacts are closed.

Step 7. Remove the voltages.

Step 8. Press the Off switch on the front panel and verify that the DGC-2000 resets to the Ready mode and that all output contacts open.

Low Oil Pressure

Step 1. Apply in parallel 120 Vac to phase A to neutral (terminals 32 and 29), phase B to neutral (terminals 31 and 29), and phase C to neutral (terminals 30 and 29).

- Step 2. Press the Run switch on the front panel.
- Step 3. Wait ten seconds after crank disconnect. Increase the resistance across the Oil Pressure sender input (terminals 16 and 5) until a Pre-Alarm occurs.
- Step 4. Verify that the DGC-2000 display value is 25 ± 2 psi when Pre-Alarm occurs.
- Step 5. Verify that the DGC-2000 displays an alternately flashing dark field in the oil pressure location and that the Pre-Alarm output contact has closed.
- Step 6. While monitoring displayed oil pressure, further increase the resistance across the Oil Pressure sender input until a low oil pressure shutdown occurs.

NOTE

Oil Pressure displayed value is 0 below 15 psi.

- Step 7. Verify that the DGC-2000 displayed value is within 0 to 17 PSI when shutdown occurs.
- Step 8. Verify that the DGC-2000 display indicates LOW OIL PRESSURE ALARM and that only the Alarm, Air Damper, and Low Oil Pressure output contacts are closed.
- Step 9. Remove the voltage and return the resistance to 60 ohms.
- Step 10. Press the Off switch on the front panel and verify that the DGC-2000 resets to the Ready mode and that all output contacts open.

High Coolant Temperature

- Step 1. Apply in parallel 120 Vac to phase A to neutral (terminals 32 and 29), phase B to neutral (terminals 31 and 29), and phase C to neutral (terminals 30 and 29).
- Step 2. Press the Run switch on the front panel.
- Step 3. Wait 60 seconds after crank disconnect. Decrease the resistance across the Coolant Temperature sender input (terminals 20 and 5) until a Pre-Alarm occurs.
- Step 4. Verify that the DGC-2000 display value is 250 ± 5 degrees when Pre-Alarm occurs.
- Step 5. Verify that the DGC-2000 displays an alternately flashing dark field in the coolant temperature location and that the Pre-Alarm output contact has closed.
- Step 6. While monitoring displayed coolant temperature, further decrease the resistance across the Coolant Temperature sender input until an over temperature shutdown occurs.
- Step 7. Verify that the DGC-2000 displayed value is 275 ± 6 degrees when shutdown occurs.
- Step 8. Verify that the DGC-2000 indicates OVER TEMP ALARM and that only the Alarm, Pre-Alarm, Air Damper, and High Coolant Temperature output contacts are closed.
- Step 9. Remove the voltage and return the resistance to 100 ohms.
- Step 10. Press the Off switch on the front panel and verify that the DGC-2000 resets to the Ready mode and that all output contacts open.

Air Damper

- Step 1. Apply in parallel 120 Vac to phase A to neutral (terminals 32 and 29), phase B to neutral (terminals 31 and 29), and phase C to neutral (terminals 30 and 29).
- Step 2. Press the Run switch on the front panel.
- Step 3. Apply a contact closure across the Air Damper Inputs (terminals 9 and 10).
- Step 4. Verify that the DGC-2000 indicates AIR DAMPER SHUTDOWN (CLOSED) and that only the Alarm and Air Damper output contacts are closed.
- Step 5. Open the contact across the Air Damper inputs.
- Step 6. Press the Off switch on the front panel and verify that the DGC-2000 resets to the Ready mode and that all output contacts open.
- Step 7. Remove the voltage.

Emergency Stop

- Step 1. Apply in parallel 120 Vac to phase A to neutral (terminals 32 and 29), phase B to neutral (terminals 31 and 29), and phase C to neutral (terminals 30 and 29).

- Step 2. Press the Run switch on the front panel.
- Step 3. Open the contact across the Emergency Stop inputs (terminals 7 and 8).
- Step 4. Verify that the DGC-2000 indicates EMERGENCY SHUTDOWN SWITCH PRESSED and that all output contacts are open.
- Step 5. Reapply the contact closure across the Emergency Stop inputs.
- Step 6. Press the Off switch on the front panel and verify that the DGC-2000 resets to the Ready mode and that all output contacts open.
- Step 7. Remove the voltage.

Low Coolant Level

- Step 1. Apply in parallel 120 Vac to phase A to neutral (terminals 32 and 29), phase B to neutral (terminals 31 and 29), and phase C to neutral (terminals 30 and 29).
- Step 2. Press the Run switch on the front panel.
- Step 3. Close the Low Coolant Level contact.
- Step 4. Verify that the DGC-2000 indicates LOW COOLANT LEVEL and that the Alarm contact is closed.
- Step 5. Open the Low Coolant Level contact.
- Step 6. Press the Off switch on the front panel and verify that the DGC-2000 resets to the Ready mode and that all output contacts open.
- Step 7. Remove the voltage.

This completes the Test Procedures.

This page intentionally left blank.

SECTION 6 • MODBUS™ COMMUNICATIONS

GENERAL

This section describes the Modbus™ communications protocol employed by the DGC-2000 and how to exchange information with DGC-2000 over a Modbus™ network. The DGC 2000 communicates by emulating a subset of the Modicon 984 Programmable Controller. Communications allow the operator to monitor the DGC-2000 Controller from a remote location or change parameter settings. A rear RS-232 port provides a permanent interface for remote communications.

Interface

The rear panel interface uses a standard RS-232 (DB-9) connector. The communications protocol is compatible with readily available modem/terminal software. The RS-232 communication port supports full duplex operation.

For all communication ports :

- The communications baud rate is fixed at 9600.
- The number of data bits is fixed at 8.
- The parity is fixed at NONE (N).
- The number of stop bits is fixed at 1.

Applications

Rear panel communication port may be used to interface terminals, computers, serial printers, modems, and intermediate communication/control interfaces such as RS-232 serial multiplexers. DGC-2000 communications protocol supports only the RTU mode.

INTRODUCTION TO MODBUS™ PROTOCOL

Modbus™ communications use a master-slave technique in which only the master can initiate a transaction. This transaction is called a query. When appropriate, a slave (DGC-2000) responds to the query. When a Modbus™ master communicates with a slave, information is provided or requested by the master.

All supported data can be read and written as specified in the register table. Abbreviations are used in the *Register Table* to indicate the register type. Register types are:

Read/Write= RW
Read only = R
Write only = W

DGC-2000 MODBUS™ PROTOCOL

When a slave receives a query, the slave responds by either supplying the requested data to the master or performing the requested action. A slave device never initiates communications on the Modbus™, and will always generate a response to the query unless certain error conditions occur. The DGC-2000 is designed to communicate on the Modbus™ only as a slave device.

A master can only query slaves individually. If a query requests actions unable to be performed by the slave, the slave response message contains an exception response code defining the error detected.

Message Structure

Master initiated queries and DGC-2000 responses share the same message structure. Each message is comprised of four message fields. They are:

- Device Address
- Function Code
- Data Block
- Error Check field

Device Address Field

The device address field contains the unique Modbus™ address of the slave being queried. The addressed slave repeats the address in the device address field of the response message. This field is 1 byte.

The DGC-2000 device address can be any value in the Modbus™ protocol device address range (1- 247). A query with a device address signifies a broadcast message to all slaves. The DGC-2000 responds only to preset multiple registers broadcast queries.

Function Code Field

The function code field in the query message defines the action to be taken by the addressed slave. This field is echoed in the response message, and is altered by setting the most significant bit (MSB) of the field to 1 if the response is an error response. This field is 1 byte.

The DGC-2000 maps all parameters into the Modicon 984 holding register address space (4XXXX) and supports the following function codes.

- Function 03 - read holding registers
- Function 08, sub-function 00 - diagnostics: return query data
- Function 16 - preset multiple registers, non-broadcast and broadcast

The only broadcast query supported by the DGC-2000 is the preset multiple registers query.

Data Block Field

The query data block contains additional information needed by the slave to perform the requested function. The response data block contains data collected by the slave for the queried function. An error response will substitute an exception response code for the data block. The length of this field varies with each query. See the register holding table for interpretation of the data.

Error Check Field

The error check field provides a method for the slave to validate the integrity of the query message contents and allows the master to confirm the validity of response message contents. This field is 2 bytes.

SERIAL TRANSMISSION DETAILS

A standard Modbus™ network offers two transmission modes for communication: ASCII or remote terminal unit (RTU). The DGC-2000 supports only the RTU mode.

Each 8-bit byte in a message contains two 4-bit hexadecimal characters. The message is transmitted in a continuous stream with the LSB of each byte of data transmitted first. Transmission of each 8-bit data byte occurs with one start bit and one stop bit. Even parity checking is performed. The transmission baud rate is user-selectable, and can be set at installation and altered during real-time operation. If altered, the new baud rate and/or parity will not be enforced until the response message to the current query has been completed. The DGC-2000 supported baud rate is 9600.

<p style="text-align: center;">NOTE</p>
--

<p>DGC-2000 supports only RS-232 compatible serial interfaces accessible from the rear panel.</p>

MESSAGE FRAMING AND TIMING CONSIDERATIONS

When receiving a message, the DGC-2000 allows a maximum inter-byte latency of up to 3.5 to 4.0 character times before considering the message complete.

Once a valid query is received, the DGC-2000 waits a minimum amount of time before responding. This time delay is set in the remote delay time register (40052). This register contains a value from 1 - 20 representing 10 - 200 milliseconds. The default value is 1 (10 milliseconds). The user may set the remote delay time register to 0 to minimize response latency.

Table 6-1 provides the response message transmission time (in seconds) and 3.5 character times (in milliseconds) for various message lengths and baud rate.

Table 6-1. Timing Considerations

Baud Rate	3.5 Character Time (ms)	Message Tx Time (Sec.)	
		128 Bytes	256 Bytes
9600	4.0104	0.15	0.29

ERROR HANDLING AND EXCEPTION RESPONSES

Any query received that contains a non-existent device address, a framing error, or CRC error is ignored. No response is transmitted. Queries addressed to a DGC-2000 with an unsupported function code, unsupported register references, or illegal values in the data block result in an error response message with an exception response code. The exception response codes supported by the DGC-2000 are provided in Table 6-2.

Table 6-2. Supported Exception Response Codes

Code	Name	Meaning
01	Illegal Function	The query Function/Sub-function Code is unsupported; query read of more than 125 registers; query preset of more than 100 registers; query preset without password clearance.
02	Illegal Data Address	A register referenced in the data block does not support queried read/write; query preset of a subset of a numerical register group.
03	Illegal Data Value	A preset register data block contains an incorrect number of bytes or one or more data values out of range.

COMMUNICATION HARDWARE REQUIREMENTS

Section 4, *Installation*, illustrates the IBM PC - AT type serial port connections. When using RS-232 communications, pin 8 to pin 7 and pin 4 to pin 6 are internally connected in the DGC-2000 to satisfy handshaking requirements.

DETAILED MESSAGE QUERY AND RESPONSE

A detailed description of DGC-2000 supported message queries and responses is provided in the following paragraphs.

Read Holding Registers Query

This query message requests a register or block of registers to be read. The data block contains the starting register address and the quantity of registers to be read. A register address of N will read holding register N+1.

Device Address
 Function Code 03 (hex)
 Starting Address Hi
 Starting Address Lo
 No. of Registers Hi
 No. of Registers Lo
 CRC error check

The number of registers cannot exceed 125 without causing an error response with the exception code for an illegal function.

Queries to read only or unsupported registers result in an error response with exception code for an illegal data address.

Queries to read without valid logon password clearance result in an error response with exception code of illegal function.

Read Holding Registers Response

The response message contains the data queried. The data block contains the block length in bytes followed by the data for each requested register. For each requested register, there is one Data Hi and one Data Lo. Attempting to read an unused register or a register which does not support a read results in an error response with the exception code for an illegal data address.

Device Address
 Function Code 03 (hex)
 Byte Count
 Data Hi (For each requested register, there is one Data Hi and one Data Lo.)
 Data Lo
 Data Hi
 Data Lo
 CRC error check

One-Half of Slave Response Frame Sent Back to Master (Frame Is Continuous)

Address	Function Code Read Multiple Register	Data Output Register Hi 40112	Data Output Register Lo 40112	Data Output Registers Hi 40113
7dh	03h	00	45h	12h

One-Half of Slave Response Frame Sent Back to Master (Continuation Of First One-Half)

Data Output Registers Lo 40113	Data Output Registers Hi 40114	Data Output Registers Lo 40114	Checksum Hi	Checksum Lo
55h	21h	45h	nn	nn

Return Query Data

This query contains data to be returned (looped back) in the response. The response and query messages should be identical.

Device Address
 Function Code 08 (hex)
 Sub-function Hi 00 (hex)
 Sub-function Lo 00 (hex)
 Data Hi
 Data Lo
 CRC error check

Return Query

A query message requests a register or block of registers to be written. The data block contains the starting address and the quantity of registers to be written, followed by the Data Block byte count and data. The DGC-2000 will perform the write when the device address is the same as the DGC-2000 remote address or when the device address is 0. A device address is 0 for a broadcast query.

A register address of N will write Holding Register N+1.

No data will be written if any of the following exceptions occur.

- Queries to write to Read Only or unsupported registers result in an error response with Exception Code of Illegal Data Address.
- Queries attempting to write more than 100 registers cause an error response with Exception Code Illegal Function.
- An incorrect Byte Count will result in an error response with Exception Code of "Illegal Data Value.
- A query to write which is not preceded by a valid Password Clearance query results in an error response with Exception Code of "Illegal Function.
- There are several instances of registers that are grouped together to collectively represent a single numerical (vs. ASCII string) DGC-2000 register value (DP, FP, TP). A query to write a subset of such a register group will result in an error response with Exception Code "Illegal Data Address.
- A query to write an illegal value (out of range) to a register results in an error response with Exception Code of "Illegal Data Value.

Device Address

Function Code 10 (hex)

Starting Address Hi

Starting Address Lo

No. of Registers Hi

No. of Registers Lo

Byte Count

Data Hi

Data Lo

.

.

.

Data Hi

Data Lo

CRC Error Check

Return Response

The response message echoes the starting address and the number of registers. There is no response message when the query is broadcast.

Device Address

Function Code 10 (hex)

Starting Address Hi

Starting Address Lo

No. of Registers Hi

No. of Registers Lo

CRC Error Check

Preset Multiple Register Query

A Preset Multiple Register query of Holding Register 40253 (Logon Password) containing the ASCII character string for the DGC-2000 password grants permission to access the DGC-2000 parameters until a pre-set multiple register query of holding register 40031 (Logoff) occurs.

The device address is 0 for a broadcast query.

The query starting address must be 0076 and as many as 8 characters (4 registers) can be used for the password. Data containing a password of less than 8 characters must include the string termination character (0). For example, if the password is ABCDEFGH, then the query data block would consist of the following 4 registers:

Query Address	Query Data
0252	AB
0253	CD
0254	EF
0255	GH

However, a password of WXYZ would require the following query data:

Query Address	Query Data
0252	WX
0253	YZ
0254	00

A password of WXY would require the following query data:

Query Address	Query Data
0252	WX
0253	Y0

Data in excess of 8 characters or following the string termination character (0) is ignored.

An error response will result only for the following exception: an incorrect Byte Count will result in an error response with Exception Code of Illegal Data Value.

Device Address
Function Code 10 (hex)
Starting Address Hi 00
Starting Address Lo 252
No. of Registers Hi 00
No. of Registers Lo 01 - 04
Password byte count
Password ASCII character 1
.
.
.
Password ASCII character N
CRC Error Check

Preset Multiple Register Response

The response message echoes the starting address and the number of registers. There is no response message when the query is broadcast.

Device Address
Function Code 10 (hex)
Starting Address Hi 00
Starting Address Lo 252
No. of Registers Hi
No. of Registers Lo
CRC Error Check

CHANGING THE LOGON PASSWORD

The current password can be altered by following a Password Clearance query with a general Preset Multiple Register query with starting address in the Remote Password register group (40252 - 40256). The new password can be up to 8 characters in length, beginning with register 40253. All characters subsequent to the initial 8 are ignored. By choosing a starting address other than 40253, a portion of the

existing password can be overwritten to form a new password. The string termination character (0) must be included when altering the length of a password unless the new password is 8 characters long.

For example, to change the password from ABCD to ABC, the query data is:

Register Address	Register Data
0253	C0

To change the password from ABCD to WXYZ, the query data is:

Register Address	Register Data
0252	WX
0253	YZ

Finally, to change the password from ABC to ABCD, the query data can be

Register Address	Register Data
0253	CD
0254	00

or could be

Register Address	Register Data
0252	AB
0253	CD
0254	00

DATA FORMATS

Some DGC-2000 data must be reformatted for transmission over the Modbus network. Parameters whose values can exceed 9999 but not exceed 99,999,999 are represented in double precision format. Parameters whose values can exceed 99,999,999 must be formatted in triple precision. Single byte data resides in the register least-significant byte with the most-significant byte set to zero. Negative values (single and double precision only) are represented by a sign bit (register MSB) and magnitude.

Double Precision Data Format

Modbus double precision data format uses two consecutive registers to represent a data value. The first register contains the high-order 16 bits of double precision data, and is the actual data value divided by 10,000.

The second register contains the low-order 16 bits of double precision data, and is the actual data value modulus 10,000. The format is:

$$\text{Double precision} = A(10,000) + B$$

Triple Precision Data Format

Modbus triple precision data format uses three consecutive registers (A, B, and X) to represent the magnitude of a data value. The first register contains the high-order 16 bits of triple precision data, and is the magnitude of the actual value divided by 100,000,000. The register MSB is the sign bit. The modulus from this operation is divided by 10,000 to arrive at the value of the second register, and the modulus of this last operation is the value of the third register (the low-order 16 bits of triple precision). The format is:

$$\text{Triple precision} = A(10,000)^2 + B(10,000) + X$$

The MSB is the sign bit for triple precision values (0 = positive). Negative values are reported as a sign and a magnitude. Triple precision format allows a maximum value of 9.99×10^{11} . The maximum range of several holding registers can exceed this value. If in actual operation, the working value is expected to exceed this value, the floating point data format should be used. These holding registers are marked with an asterisk in the paragraphs for the *Register Table*.

Error Check

This field contains a two-byte CRC value for transmission error detection. The master first calculates the CRC and appends it to the query message. The DGC-2000 recalculates the CRC value for the received query and performs a comparison to the query CRC value to determine if a transmission error has occurred. If so, no response message is generated. If no transmission error has occurred, the slave calculates a new CRC value for the response message and appends it to the message for transmission.

The CRC calculation is performed using all bytes of the device address, function code and data block fields. A 16-bit CRC-register is initialized to all 1's. Then each eight-bit byte of the message is used in the following algorithm:

First, exclusive-OR the message byte with the low-order byte of the CRC-register. The result, stored in the CRC-register, will then be right-shifted eight times. The CRC-register MSB is zero-filled with each shift. After each shift, the CRC-register LSB is examined. If the LSB IS a 1, the CRC-register is then exclusive-ORed with the fixed polynomial value A001 (hex) prior to the next shift. Once all bytes of the message have undergone the above algorithm, the CRC-register will contain the message CRC value to be placed in the error check field.

Settings Source Register (40081)

Write to this register to select the settings group to be used (Factory, OEM or USER) as the source for retrieving settings and the settings group to be used (OEM or USER only).

Saving Settings Register (40082)

Writing any value to this register causes settings values to be written into the DGC-2000 nonvolatile memory at the settings group specified in the settings source register (OEM or USER only).

CALCULATING TOTAL KILOWATT-HOURS

Because of the way kilowatt-hours are tabulated and stored in the DGC-2000, kilowatt-hours cannot be read directly from Modbus. However, kilowatt-hours may be calculated using the following equation:

$$\text{Total kW-h} = \text{Total kW-h Saved in EE} + \frac{\text{Total kW-min Since Last Save}}{60}$$

Where: "Total kW-h Saved in EE" resides in Modbus registers 40427 through 40429

"Total kW-min Since Last Save" resides in registers 40435 through 40437

In terms of the values contained in the Modbus registers, the above equation for total kilowatt-hours can be expressed as follows:

$$[(40427) \times 10^8] + [(40428) \times 10^4] + (40429) + \frac{([(40435) \times 10^8] + [(40436) \times 10^4] + (40437))}{60}$$

MAPPING REGISTERS INTO MODICON ADDRESS SPACE

Conventions

The Data Format column uses the following abbreviations.

DP	Double precision
TP	Triple Precision

Data formatted in double precision uses a two register group designated (a) and (b) and is defined as follows:

Register (a) - two hi-order bytes

Register (b) - two lo-order bytes

Data which are represented in triple precision format use a group of three registers designated (a), (b), and (x).

Register (a) - two hi-order bytes

Register (b) - two mid-order bytes

Register (x) - two lo-order bytes

Other register groups using the (a), (b), etc. designators are an ordered data group of consecutive ASCII characters or data bytes.

Register Table

The DGC-2000 maps all parameters into the holding register address space (4XXXX).

NOTE
Query address n will access the holding register n+1.

Holding Register	Parameter	Variable's Allowed Range	Read/Write Supported	Data Format	Units
PRODUCT ACCESS INFORMATION					
40252	<Reserved>				
40253	User Ltd Access Password(a)	'A'-'Z', 'a'-'z', '_', '0' - '9'	- W		
40254	User Ltd Access Password(b)		- W		
40255	User Ltd Access Password(c)		- W		
40256	User Ltd Access Password(d)		- W		
40257	<Reserved>				
40006	Front Panel Password(a)	All front panel pushbuttons except for RUN, OFF, AUTO	R -		
40007	Front Panel Password(b)		R -		
40008	Front Panel Password(c)		R -		
40009	Front Panel Password(d)		R -		
40010	<Reserved>				
40011	<Reserved>				
40012	<Reserved>				
40013	<Reserved>				
40014	User Ttl Access Password(a)	'A'-'Z', 'a'-'z', '_', '0'-'9'	- W		
40015	User Ttl Access Password(b)		- W		
40016	User Ttl Access Password(c)		- W		
40017	User Ttl Access Password(d)		- W		
40030	<Reserved>				
40031	Logoff	Data=Don't Care	- W		
40032	<Reserved>				
COMMUNICATION PARAMETERS					
40051	Comm Baud Rate	0	R W	0 =9600	Baud

Holding Register	Parameter	Variable's Allowed Range	Read/Write Supported	Data Format	Units
40052	Remote Delay Time	0-20	R W	0=Min. 1 =10 2 = 20 etc. 20 =200	MilliSec 10
40053	Comm Parity	0-2	R W	0 =None 1 =Odd 2 =Even	
40054	Device Address	1-247	R W		
40055	Modern Time Delay	0-9999	R W		Microseconds
40056	Embedded Code Version No.	100-9999	R -		Version No. x 100

PARAMETER SETTINGS

40078	Remote (PC) Emergency Stop	0-1	- W	0 =Off 1 = Stop	
40079	Remote Start / Stop	0-1	- W	0 =Stop 1 =Start	
40080	<Reserved>				
40081	Settings Source	0-2	R W	0 =Factory 1 =OEM 2 =User	
40082	Save Settings	Data=Don't Care	- W		
40083	<Reserved>				

SYSTEM PARAMETERS

40091	Generator Connection	0-2	R W	0=3ph L-L 1=3ph L-N 2=1ph A-B	
40092	NFPA Level	0-2	R W	0 =Off 1 =Level 1 2 =Level 2	
40093	Unit System	0-1	R W	0=English 1=Metric	
40094	Battery Volts	0-1	R W	0=12 VDC 1=24 VDC	
40095	Generator Frequency	0-1	R W	0=50 HZ 1=60 HZ	
40096	Rated Engine RPM	750-3600	R W		RPM
40097	Rated Engine RPM Minimum	750	R -		RPM
40098	Rated Engine RPM Maximum	3600	R -		RPM
40099	Rated Engine RPM Stepsize	50	R -		RPM
40100	Number Flywheel Teeth	50-500	R W		
40101	Number Flywheel Teeth Minimum	50	R -		
40102	Number Flywheel Teeth Maximum	500	R -		
40103	Number Flywheel Teeth Stepsize	1	R -		
40104	Genset KW Rating	25-9999	R W		KWatt
40105	Genset KW Rating Minimum	25	R -		KWatt
40106	Genset KW Rating Maximum	9999	R -		KWatt
40107	Genset KW Rating Stepsize	1	R -		KWatt

Holding Register	Parameter	Variable's Allowed Range	Read/Write Supported	Data Format	Units
40108	No Load Cool Down Time	0-60	R W		Minutes
40109	No Load Cool Down Time Minimum	0	R -		Minutes
40110	No Load Cool Down Time Maximum	60	R -		Minutes
40111	No Load Cool Down Time Stepsize	5	R -		Minutes
40112	Alternator Frequency Rated	100-900	R W		Hertz
40113	Alternator Frequency Rated Minimum	100	R -		Hertz
40114	Alternator Frequency Rated Maximum	900	R -		Hertz
40115	Alternator Frequency Rated Stepsize	1	R -		Hertz
GENERATOR PT PRIMARY					
40121	Voltage(a)	1-15000	R W	DP	VoltsAC x 10000
40122	Voltage(b)		R W	DP	VoltsAC
40123	Voltage Minimum(a)	1	R -	DP	VoltsAC x 10000
40124	Voltage Minimum(b)		R -	DP	VoltsAC
40125	Voltage Maximum(a)	15000	R -	DP	VoltsAC x 10000
40126	Voltage Maximum(b)		R -	DP	VoltsAC
40127	Voltage Stepsize(a)	1	R -	DP	VoltsAC x 10000
40128	Voltage Stepsize(b)		R -	DP	VoltsAC
GENERATOR PT SECONDARY					
40129	Voltage	1-480	R W		VoltsAC
40130	Voltage Minimum	1	R -		VoltsAC
40131	Voltage Maximum	480	R -		VoltsAC
40132	Voltage Stepsize	1	R -		VoltsAC
GENERATOR CT PRIMARY					
40133	Current	1-5000	R W		AmpsAC
40134	Current Minimum	1	R -		AmpsAC
40135	Current Maximum	5000	R -		AmpsAC
40136	Current Stepsize	1	R -		AmpsAC
BUS PT PRIMARY					
40141	Voltage(a)	1-15000	R W	DP	VoltsAC x 10000
40142	Voltage(b)		R W	DP	VoltsAC
40143	Voltage Minimum(a)	1	R -	DP	VoltsAC x 10000
40144	Voltage Minimum(b)		R -	DP	VoltsAC
40145	Voltage Maximum(a)	15000	R -	DP	VoltsAC x 10000
40146	Voltage Maximum(b)		R -	DP	VoltsAC
40147	Voltage Stepsize(a)	1	R -	DP	VoltsAC x 10000
40148	Voltage Stepsize(b)		R -	DP	VoltsAC

Holding Register	Parameter	Variable's Allowed Range	Read/Write Supported	Data Format	Units
BUS PT SECONDARY					
40149	Voltage	1-480	R W		VoltsAC
40150	Voltage Minimum	1	R -		VoltsAC
40151	Voltage Maximum	480	R -		VoltsAC
40152	Voltage Stepsize	1	R -		VoltsAC
LOW FUEL PRE-ALARM					
40181	Enable	0-1	R W	0 =Off 1 =On	
40182	Threshold	10-100	R W		% Full Tank
40183	Minimum	10	R -		% Full Tank
40184	Maximum	100	R -		% Full Tank
40185	Stepsize	1	R -		% Full Tank
LOW COOL TEMP PRE-ALARM					
40186	Enable	0-1	R W	0 =Off 1 =On	
40187	Threshold	40-100	R W		DegF
40188	Minimum	40	R -		DegF
40189	Maximum	100	R -		DegF
40190	Stepsize	1	R -		DegF
BATTERY OVERVOLTAGE PRE-ALARM					
40191	Enable	0-1	R W	0 =Off 1 =On	
40192	Threshold	140-160 (12V) 240-320 (24V)	R W		.1 VoltDC
40193	Minimum	140 / 240	R -		.1 VoltDC
40194	Maximum	160 / 320	R -		.1 VoltDC
40195	Stepsize	1	R -		.1 VoltDC
MAINTENANCE INTERVAL PRE-ALARM					
40196	Enable	0-1	R W	0 =Off 1 =On	
40197	Threshold	0-5000	R W		Hours
40198	Minimum	0	R -		Hours
40199	Maximum	5000	R -		Hours
40200	Stepsize	10	R -		Hours
ENGINE KW OVERLOAD PRE-ALARM					
40201	Enable	0-1	R W	0 =Off 1 =On	
40202	Threshold	95-140	R W		% of Rated
40203	Minimum	95	R -		% of Rated
40204	Maximum	140	R -		% of Rated
40205	Stepsize	1	R -		% of Rated

Holding Register	Parameter	Variable's Allowed Range	Read/Write Supported	Data Format	Units
HIGH COOLANT TEMPERATURE PRE-ALARM					
40206	Enable	0-1	R W	0 =Off 1 =On	
40207	Threshold	100-280	R W		DegF
40208	Minimum	100	R -		DegF
40209	Maximum	280	R -		DegF
40210	Stepsize	1	R -		DegF
LOW OIL PRESSURE PRE-ALARM					
40211	Enable	0-1	R W	0 =Off 1 =On	
40212	Threshold	3-100	R W		PSI
40213	Minimum	3	R -		PSI
40214	Maximum	100	R -		PSI
40215	Stepsize	1	R -		PSI
LOW BATTERY VOLTAGE PRE-ALARM					
40216	Enable	0-1	R W	0 =Off 1 =On	
40217	Threshold	60-120 (12V) 120-240 (24V)	R W		.1 VoltDC
40218	Minimum	60 / 120	R -		.1 VoltDC
40219	Maximum	120 / 240	R -		.1 VoltDC
40220	Stepsize	1 (0.1 VDC)	R -		.1 VoltDC
40221	Pre-alarm Activation Time Delay	1-10	R W		Seconds
40222	Activation Time Delay Minimum	1	R -		Seconds
40223	Activation Time Delay Maximum	10	R -		Seconds
40224	Activation Time Delay Stepsize	1	R -		Seconds
WEAK BATTERY VOLTAGE PRE-ALARM					
40225	Enable	0-1	R W	0 =Off 1 =On	
40226	Threshold	40-80 (12V) 80-160 (24V)	R W		.1 VoltDC
40227	Minimum	40 / 80	R -		.1 VoltDC
40228	Maximum	80 / 160	R -		.1 VoltDC
40229	Stepsize	1 (0.1 VoltDC)	R -		.1 VoltDC
40230	Pre-alarm Activation Time Delay	1-10	R W		Seconds
40231	Activation Time Delay Minimum	1	R -		Seconds
40232	Activation Time Delay Maximum	10	R -		Seconds
40233	Activation Time Delay Stepsize	1	R -		Seconds

LOGON PASSWORD (40252-7)

Holding Register	Parameter	Variable's Allowed Range	Read/Write Supported	Data Format	Units
HIGH COOLANT TEMPERATURE ALARM					
40281	Enable	0-1	R W	0 =Off 1 =On	
40282	Shutdown Enable	0-1	R W	0 =Off 1 =On	
40283	Threshold	100-280	R W		DegF
40284	Minimum	100	R -		DegF
40285	Maximum	280	R -		DegF
40286	Stepsize	1	R -		DegF
40287	Arming Delay after Crank Disconnect	60	R W		Seconds
40288	Arming Delay Minimum	60	R -		Seconds
40289	Arming Delay Maximum	60	R -		Seconds
40290	Arming Delay Stepsize	0	R -		Seconds
LOW OIL PRESSURE ALARM					
40291	Enable	0-1	R W	0 =Off 1 =On	
40292	Shutdown Enable	0-1	R W	0 =Off 1 =On	
40293	Threshold	3-100	R W		PSI
40294	Minimum	3	R -		PSI
40295	Maximum	100	R -		PSI
40296	Stepsize	1	R -		PSI
40297	Arming Delay after Crank Disconnect	5-15	R W		Seconds
40298	Arming Delay Minimum	5	R -		Seconds
40299	Arming Delay Maximum	15	R -		Seconds
40300	Arming Delay Stepsize	1	R -		Seconds
OVERSPEED ALARM					
40301	Enable	0-1	R W	0 =Off 1 =On	
40302	Shutdown Enable	0-1	R W	0 =Off 1 =On	
40303	Threshold	105-140	R W		% of Rated
40304	Minimum	105	R -		% of Rated
40305	Maximum	140	R -		% of Rated
40306	Stepsize	1	R -		% of Rated
40307	Alarm Activation Time Delay	0-500	R W		MilliSec
40308	Activation Time Delay Minimum	0	R -		MilliSec
40309	Activation Time Delay Maximum	500	R -		MilliSec
40310	Activation Time Delay Stepsize	10	R -		MilliSec

Holding Register	Parameter	Variable's Allowed Range	Read/Write Supported	Data Format	Units
SENDER FAIL ALARMS					
40311	Coolant Temperature Sender Failure Alarm Enable	0-1	R W	0 =Off 1 =On	
40312	Oil Pressure Sender Failure Alarm Enable	0-1	R W	0 =Off 1 =On	
40314	Magnetic Pick-up Failure Alarm Enable	0-1	R W	0 =Off 1 =On	
40315	Loss of Generator Voltage Alarm Enable	0-1	R W	0 =Off 1 =On	
40316	Pre-alarm Buzzer Enable	0-1	R W	0 =Off 1 =On	
40317	Battery Charger Failure Pre-alarm Enable	0-1	R W	0 =Off 1 =On	
40318	Global Sender Failure Alarm Time Delay	1-10	R W		Seconds
40319	Coolant Temperature Sender Failure Alarm Activation Delay	5-30 (increment size of 5)	R W		Minutes
CRANKING PARAMETERS					
40351	Cranking Style	0-1	R W	0=Contin. 1=Cycle	
40352	Number of Crank Cycles	1-7	R W		
40353	Number of Crank Cycles Minimum	1	R -		
40354	Number of Crank Cycles Maximum	7	R -		
40355	Number of Crank Cycles Stepsize	1	R -		
40356	Cycle Crank Time	5-15	R W		Seconds
40357	Cycle Crank Time Minimum	5	R -		Seconds
40358	Cycle Crank Time Maximum	15	R -		Seconds
40359	Cycle Crank Time Stepsize	1	R -		Seconds
40360	Continuous Crank Time	1-60	R W		Seconds
40361	Continuous Crank Time Minimum	1	R -		Seconds
40362	Continuous Crank Time Maximum	60	R -		Seconds
40363	Continuous Crank Time Stepsize	1	R -		Seconds
40364	Crank Disconnect Limit	10-100	R W		% of Rated
40365	Crank Disconnect Limit Minimum	10	R -		% of Rated
40366	Crank Disconnect Limit Maximum	100	R -		% of Rated
40367	Crank Disconnect Limit Stepsize	1	R -		% of Rated
40368	Pre-crank Delay	0-30	R W		Seconds
40369	Pre-crank Delay Minimum	0	R -		Seconds
40370	Pre-crank Delay Maximum	30	R -		Seconds
40371	Pre-crank Delay Stepsize	1	R -		Seconds
40372	Pre-crank Contact after Disconnect	0-1	R W	0=Open 1=Closed	

Holding Register	Parameter	Variable's Allowed Range	Read/Write Supported	Data Format	Units
SYSTEM MONITOR					
40374	Remaining Cooldown Time	0-60	R -		Minutes
40375	<Reserved>				
40376	Active Speed Signal Sources	1-4	R -	1 =MPU 2 =ALT 3 =GEN 4 =NONE	
40377	Sender Failure Alarm Codes		R -	b0=Cool Temp b1=Oil Press b2 Reserved b3=Spd Signal b4=Gen Volt b5-b7 Not Used	
40378	Alarm Codes		R -	b0=Hi Cool Temp b1 Low Coolant Level b2=Airbox b3=E-Stop b4=Sender Fail b5=Over-crank b6=Over-speed b7=Low Oil Press	
40379	Pre-Alarm Codes		R -	b0=Hi Cool Temp b1=Low Cool Temp b2=Weak Batt b3=Low Batt b4 =Batt ov b5=Charger Fail b6=Service Due b7=kW Overload	
40380	Pre-Alarm Codes, Group 2		R -	b0=Low Oil Press b1=Low Fuel b2 Reserved b3 Reserved b4-b7 Not Used	
40381	Engine Coolant Temperature		R -		DegF
40382	Engine Oil Pressure		R -		PSI
40383	Battery Voltage		R -		.1 VoltDC
40384	Fuel Level		R -		% Full Tank
40385	Time Remaining until Maintenance		R -		Hours
40386	Accumulated Engine Runtime(a)		R -	DP	Minutes x 10000

Holding Register	Parameter	Variable's Allowed Range	Read/Write Supported	Data Format	Units
40387	Accumulated Engine Runtime(b)		R -	DP	Minutes
40388	Accumulated Engine Runtime Warranty(a)		R W	DP	Minutes x 10000
40389	Accumulated Engine Runtime Warranty(b)		R W	DP	Minutes
40390	Engine Speed(a)		R -	DP	RPM x 10000
40391	Engine Speed(b)		R -	DP	RPM
40392	Engine Load(a)		R -	DP	%
40393	Engine Load(b)		R -	DP	%

GENERATOR MONITOR

40394	Phase a-b RMS Voltage(a)		R -	DP	RMS Volt x10000
40395	Phase a-b RMS Voltage(b)		R -	DP	RMS Volt
40396	Phase b-c RMS Voltage(a)		R -	DP	RMS Volt x10000
40397	Phase b-c RMS Voltage(b)		R -	DP	RMS Volt
40398	Phase c-a RMS Voltage(a)		R -	DP	RMS Volt x10000
40399	Phase c-a RMS Voltage(b)		R -	DP	RMS Volt
40400	Phase a-n RMS Voltage(a)		R -	DP	RMS Volt x10000
40401	Phase a-n RMS Voltage(b)		R -	DP	RMS Volt
40402	Phase b-n RMS Voltage(a)		R -	DP	RMS Volt x10000
40403	Phase b-n RMS Voltage(b)		R -	DP	RMS Volt
40404	Phase c-n RMS Voltage(a)		R -	DP	RMS Volt x10000
40405	Phase c-n RMS Voltage(b)		R -	DP	RMS Volt
40406	Bus RMS Voltage(a)		R -	DP	RMS Volt x10000
40407	Bus RMS Voltage(b)		R -	DP	RMS Volt
40408	Phase a RMS Current		R -		RMS Amps
40409	Phase b RMS Current		R -		RMS Amps
40410	Phase c RMS Current		R -		RMS Amps
40411	Phase a Apparent Power(a)		R -	DP	KVA x 10000
40412	Phase a Apparent Power(b)		R -	DP	KVA
40413	Phase b Apparent Power(a)		R -	DP	KVA x 10000
40414	Phase b Apparent Power(b)		R -	DP	KVA
40415	Phase c Apparent Power(a)		R -	DP	KVA x 10000
40416	Phase c Apparent Power(b)		R -	DP	KVA
40417	3 Phase Apparent Power(a)		R -	DP	KVA x 10000
40418	3 Phase Apparent Power(b)		R -	DP	KVA
40419	Phase a Power(a)		R -	DP	KWatt x 10000
40420	Phase a Power(b)		R -	DP	KWatt
40421	Phase b Power(a)		R -	DP	KWatt x 10000
40422	Phase b Power(b)		R -	DP	KWatt
40423	Phase c Power(a)		R -	DP	KWatt x 10000
40424	Phase c Power(b)		R -	DP	KWatt
40425	3 Phase power(a)		R -	DP	KWatt x 10000
40426	3 Phase power(b)		R -	DP	KWatt
40427	Total kW-Hours saved in EE (a)		R W	TP	KWH x 10000 x 10000
40428	Total kW-Hours saved in EE (b)		R W	TP	KWH x 10000

Holding Register	Parameter	Variable's Allowed Range	Read/Write Supported	Data Format	Units
40429	Total kW-Hours saved in EE (x)		R W	TP	KWH
40430	Power Factor		R -		.01
40431	<Reserved>				
40432	<Reserved>				
40433	Generator Frequency		R -		.1 Hertz
40434	Bus Frequency		R -		.1 Hertz
40435	Total kW-Minutes since last save (a)		R -		kWm x 10000 x 10000
40436	Total kW-Minutes since last save (b)		R -		kWm x 10000
40437	Total kW-Minutes since last save (x)		R -		kWm
CONTIGUOUS WRITE BLOCK (REGROUPED PARAMETERS)					
40441	Generator Connection	0-2	R W	0=3ph L-L 1=3ph L-N 2=1ph A-B	
40442	NFPA Level	0-2	R W		
40443	Unit System	0-1	R W	0=English 1=Metric	
40444	Nominal Battery Voltage	0-1	R W	0=12 VDC 1=24 VDC	
40445	Generator Frequency	0-1	R W	0=50 HZ 1=60 HZ	
40446	Rated Engine RPM	750-3600	R W		RPM
40447	Number Flywheel Teeth	50-500	R W		
40448	Genset KW Rating	25-9999	R W		KWatt
40449	No Load Cool Down Time	0-60	R W		Minutes
40450	Alternator Frequency Rated	100-900	R W		Hertz
40451	Generator Speed Mode	Individual Bits are 0 or 1	R W		Active Speed Signals <hr/> b0=mag pick-up b1=generator b2=chg. alt. Gen. Phase Rotation <hr/> b4=0 for A-B-C b4=1 for A-C-B Maintenance Timer <hr/> b5=0 is active b5=1 to reset
GENERATOR PT PRIMARY					
40452	Voltage(a)	1-15000	R W	DP	VoltsAC x 10000
40453	Voltage(b)		R W	DP	VoltsAC
GENERATOR PT SECONDARY					
40454	Voltage	1-480	R W		VoltsAC
GENERATOR CT PRIMARY					
40455	Current	1-5000	R W		AmpsAC
40456	<Reserved>				

Holding Register	Parameter	Variable's Allowed Range	Read/Write Supported	Data Format	Units
BUS PT PRIMARY					
40457	Voltage(a)	1-15000	R W	DP	VoltsAC x 10000
40458	Voltage(b)		R W	DP	VoltsAC
BUS PT SECONDARY					
40459	Voltage	1-480	R W		VoltsAC
LOW FUEL PRE-ALARM					
40460	Enable	0-1	R W	0 =Off 1 =On	
40461	Threshold	10-100	R W		% Full Tank
LOW COOL TEMP PRE-ALARM					
40462	Enable	0-1	R W	0 =Off 1 =On	
40463	Threshold	40-100	R W		DegF
BATTERY OVERVOLTAGE PRE-ALARM					
40464	Enable	0-1	R W	0 =Off 1 =On	
40465	Threshold	140-160 (12V) 240-320 (24V)	R W		.1 VoltDC
MAINTENANCE INTERVAL PRE-ALARM					
40466	Enable	0-1	R W	0 =Off 1 =On	
40467	Threshold	0-5000	R W		Hours
ENGINE KW OVERLOAD PRE-ALARM					
40468	Enable	0-1	R W	0 =Off 1 =On	
40469	Threshold	95-140	R W		% of Rated
HIGH COOLANT TEMPERATURE PRE-ALARM					
40470	Enable	0-1	R W	0 =Off 1 =On	
40471	Threshold	100-280	R W		DegF
LOW OIL PRESSURE PRE-ALARM					
40472	Enable	0-1	R W	0 =Off 1 =On	
40473	Threshold	3-100	R W		PSI
LOW BATTERY VOLTAGE PRE-ALARM					
40474	Enable	0-1	R W	0 =Off 1 =On	
40475	Threshold	60-120 (12V) 120-240 (24V)	R W		.1 VoltDC
40476	Pre-alarm Activation Time Delay	1-10	R W		Seconds
WEAK BATTERY VOLTAGE PRE-ALARM					
40477	Enable	0-1	R W	0 =Off 1 =On	
40478	Threshold	40-80 (12V) 80-160 (24V)	R W		.1 VoltDC

Holding Register	Parameter	Variable's Allowed Range	Read/Write Supported	Data Format	Units
40479	Pre-alarm Activation Time Delay	1-10	R W		Seconds
HIGH COOLANT TEMPERATURE ALARM					
40480	Enable	0-1	R W	0 =Off 1 =On	
40481	Shutdown Enable	0-1	R W	0 =Off 1 =On	
40482	Threshold	100-280	R W		DegF
40483	Arming Delay after Crank Disconnect	60	R W		Seconds
LOW OIL PRESSURE ALARM					
40484	Enable	0-1	R W	0 =Off 1 =On	
40485	Shutdown Enable	0-1	R W	0 =Off 1 =On	
40486	Threshold	3-100	R W		PSI
40487	Arming Delay after Crank Disconnect	5-15	R W		Seconds
OVERSPEED ALARM					
40488	Enable	0-1	R W	0 =Off 1 =On	
40489	Shutdown Enable	0-1	R W	0 =Off 1 =On	
40490	Threshold	105-140	R W		% of Rated
40491	Alarm Activation Time Delay	0-500	R W		MilliSec
SENDER FAIL ALARMS					
40492	Coolant Temperature Sender Failure Alarm Enable	0-1	R W	0 =Off 1 =On	
40493	Oil Pressure Sender Failure Alarm Enable	0-1	R W	0 =Off 1 =On	
40495	Magnetic Pick-up Failure Alarm Enable	0-1	R W	0 =Off 1 =On	
40496	Loss of Generator Voltage Alarm Enable	0-1	R W	0 =Off 1 =On	
40497	Pre-alarm Buzzer Enable	0-1	R W	0 =Off 1 =On	
40498	Battery Charger Failure Pre-alarm Enable	0-1	R W	0 =Off 1 =On	
40499	Global Sender Failure Alarm Time Delay	0-10	R W		Seconds
CRANKING PARAMETERS					
40500	Cranking Style	0-1	R W	0=Contin. 1=Cycle	
40501	Number of Crank Cycles	1-7	R W		
40502	Cycle Crank Time	5-15	R W		Seconds
40503	Continuous Crank Time	1-60	R W		Seconds
40504	Crank Disconnect Limit	10-100	R W		% of Rated
40505	Pre-crank Delay	0-30	R W		Seconds
40506	Pre-crank Contact after Disconnect	0-1	R W	0=Open 1=Closed	

Holding Register	Parameter	Variable's Allowed Range	Read/Write Supported	Data Format	Units
SYSTEM MONITOR					
40507	Accumulated Engine Runtime Warranty(a)		R W	DP	Minutes x 10000
40508	Accumulated Engine Runtime Warranty(b)		R W	DP	Minutes
CALIBRATION					
40509	Voltage Calibration A(a)		R W	DP	x 10000
40510	Voltage Calibration A(b)		R W	DP	x 1
40511	Voltage Calibration B(a)		R W	DP	x 10000
40512	Voltage Calibration B(b)		R W	DP	x 1
40513	Voltage Calibration C(a)		R W	DP	x 10000
40514	Voltage Calibration C(b)		R W	DP	x 1
40515	Voltage Calibration N(a)		R W	DP	x 10000
40516	Voltage Calibration N(b)		R W	DP	x 1
40517	Current Calibration A(a)		R W	DP	x 10000
40518	Current Calibration A(b)		R W	DP	x 1
40519	Current Calibration B(a)		R W	DP	x 10000
40520	Current Calibration B(b)		R W	DP	x 1
40521	Current Calibration C(a)		R W	DP	x 10000
40522	Current Calibration C(b)		R W	DP	x 1
40523	Current Calibration N(a)		R W	DP	x 10000
40524	Current Calibration N(b)		R W	DP	x 1
40525	Coolant Temperature 0(a)		R W	DP	x 10000
40526	Coolant Temperature 0(b)		R W	DP	x 1
40527	Coolant Temperature 1(a)		R W	DP	x 10000
40528	Coolant Temperature 1(b)		R W	DP	x 1
40529	Coolant Temperature 2(a)		R W	DP	x 10000
40530	Coolant Temperature 2(b)		R W	DP	x 1
40531	Coolant Temperature 3(a)		R W	DP	x 10000
40532	Coolant Temperature 3(b)		R W	DP	x 1
40533	Coolant Temperature 4(a)		R W	DP	x 10000
40534	Coolant Temperature 4(b)		R W	DP	x 1
40535	Coolant Temperature 5(a)		R W	DP	x 10000
40536	Coolant Temperature 5(b)		R W	DP	x 1
40537	Coolant Temperature 6(a)		R W	DP	x 10000
40538	Coolant Temperature 6(b)		R W	DP	x 1
40539	Coolant Temperature 7(a)		R W	DP	x 10000
40540	Coolant Temperature 7(b)		R W	DP	x 1
40541	Coolant Temperature 8(a)		R W	DP	x 10000
40542	Coolant Temperature 8(b)		R W	DP	x 1
40543	Coolant Temperature 9(a)		R W	DP	x 10000
40544	Coolant Temperature 9(b)		R W	DP	x 1
40545	Coolant Temperature 10(a)		R W	DP	x 10000
40546	Coolant Temperature 10(b)		R W	DP	x 1
40547	Coolant Temperature 11(a)		R W	DP	x 10000
40548	Coolant Temperature 11(b)		R W	DP	x 1
40549	Coolant Temperature 12(a)		R W	DP	x 10000

Holding Register	Parameter	Variable's Allowed Range	Read/Write Supported	Data Format	Units
40550	Coolant Temperature 12(b)		R W	DP	x 1
40551	Coolant Temperature 13(a)		R W	DP	x 10000
40552	Coolant Temperature 13(b)		R W	DP	x 1
40553	Oil Pressure 0(a)		R W	DP	x 10000
40554	Oil Pressure 0(b)		R W	DP	x 1
40555	Oil Pressure 1(a)		R W	DP	x 10000
40556	Oil Pressure 1(b)		R W	DP	x 1
40557	Oil Pressure 2(a)		R W	DP	x 10000
40558	Oil Pressure 2(b)		R W	DP	x 1
40559	Oil Pressure 3(a)		R W	DP	x 10000
40560	Oil Pressure 3(b)		R W	DP	x 1
40561	Oil Pressure 4(a)		R W	DP	x 10000
40562	Oil Pressure 4(b)		R W	DP	x 1
40563	Oil Pressure 5(a)		R W	DP	x 10000
40564	Oil Pressure 5(b)		R W	DP	x 1
40565	Oil Pressure 6(a)		R W	DP	x 10000
40566	Oil Pressure 6(b)		R W	DP	x 1
40567	Oil Pressure 7(a)		R W	DP	x 10000
40568	Oil Pressure 7(b)		R W	DP	x 1
40569	Oil Pressure 8(a)		R W	DP	x 10000
40570	Oil Pressure 8(b)		R W	DP	x 1
40571	Oil Pressure 9(a)		R W	DP	x 10000
40572	Oil Pressure 9(b)		R W	DP	x 1
40573	Oil Pressure 10(a)		R W	DP	x 10000
40574	Oil Pressure 10(b)		R W	DP	x 1
40575	Oil Pressure 11(a)		R W	DP	x 10000
40576	Oil Pressure 11(b)		R W	DP	x 1
40577	Oil Pressure 12(a)		R W	DP	x 10000
40578	Oil Pressure 12(b)		R W	DP	x 1
40579	Oil Pressure 13(a)		R W	DP	x 10000
40580	Oil Pressure 13(b)		R W	DP	x 1
SYSTEM MONITOR - Continuation					
40581	System Configuration	32, 64, 128	R W	32=AUTO 64=OFF 128=RUN	
40582	System State	0-5	R -	0=RESET 1=READY 2=CRANK 3=REST 4=RUN 5=ALARM	
CALIBRATION - Continuation					
40583	Phase angle (a)		R W	DP	
40584	Phase angle (b)		R W	DP	

Holding Register	Parameter	Variable's Allowed Range	Read/Write Supported	Data Format	Units
GENERATOR MONITOR - Continuation					
40585	Power Factor State	0-3	R	0=+LAG 1=-LEAD 2=-LAG 3=+LEAD	

This page intentionally left blank.

SECTION 7 • BESTCOMS SOFTWARE

INTRODUCTION

BESTCOMS software enables communication between the DGC-2000 and a personal computer (PC). BESTCOMS serves two main purposes. First, it provides a user friendly environment for changing DGC-2000 settings. Second, it provides on-screen, real-time metering that is updated approximately every one and one-half seconds. The interface software also allows users to save the current setting configurations and data information to a disk. Users can save multiple setups for later use which saves setup time when configuring multiple units. Without BESTCOMS, users must be familiar with the limited function operations at the DGC-2000 front panel.

INSTALLATION

BESTCOMS software contains a setup utility that installs the program on your PC. When it installs the program, an uninstall icon is created that you may use to uninstall (remove) the program from your PC. The minimum operating requirements are listed in the following paragraph.

Operating Requirements

To use BESTCOMS software, you will need the following:

- IBM compatible PC, 486DX2 or faster (100 MHz or higher microprocessor is recommended)
- Microsoft® Windows® 95 or later operating system
- CD-ROM drive
- One available RS-232 serial port

Installing DGC-2000 BESTCOMS

1. Insert the CD-ROM, provided with the DGC-2000, into the PC CD-ROM drive.
2. When the DGC-2000 Setup and Documentation CD menu appears, click the **Install** button for the BESTCOMS PC Program. The setup utility automatically installs DGC-2000 BESTCOMS on your PC.

When BESTCOMS is installed, a Basler Electric folder is added to the Windows program menu. This folder is accessed by clicking the **Start** button and pointing to **Programs**.

Configuring The System

Communication with a DGC 2000 unit can be done by a direct cable connection or through a modem. Section 4, *Installation* has the RS-232 serial link connection pin-outs. For direct connection use a standard RS-232 cable. For modem communications connection use a modem to the DGC RS-232 port and a null-modem cable. Connect another modem to the host computer with a standard RS-232 cable.

INITIALIZING COMMUNICATION WITH BESTCOMS

BESTCOMS is started by clicking the Windows **Start** button, pointing to **Programs**, the **Basler Electric** folder, and then clicking the DGC-2000 icon. At startup, a dialog box with the program title and version number is displayed briefly. After this dialog box is displayed, the Sensing Transformers screen (Figure 7-1) is displayed. Pull down the **C**ommunications menu select **O**pen and then either **R**S232 or **M**odem depending on the communication type desired. This will open the Comm Port screen like the one shown in Figure 7-2.

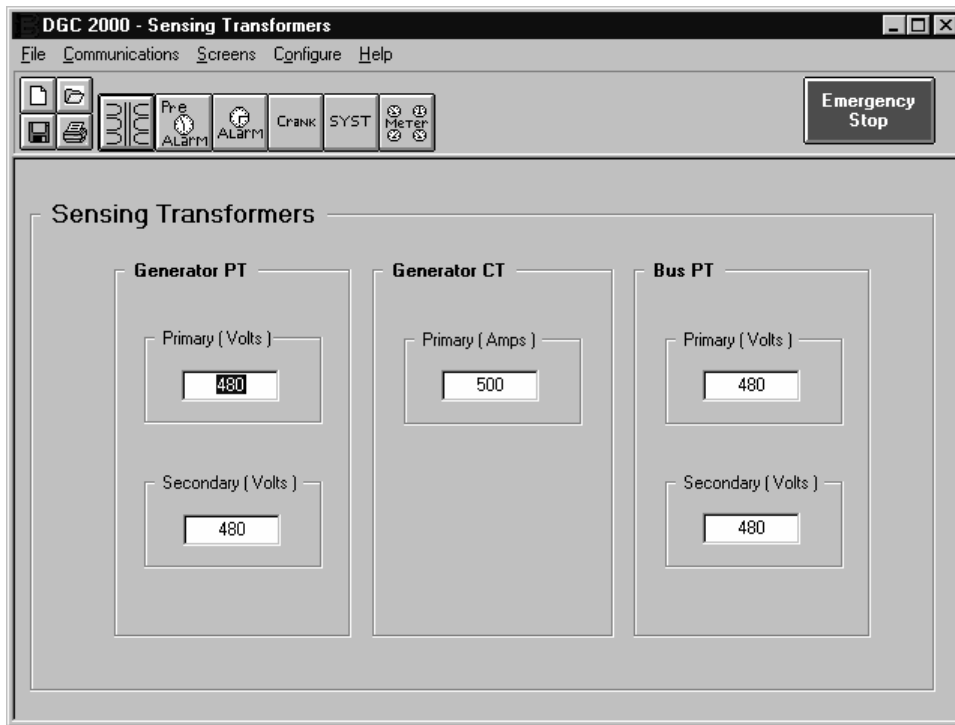

Figure 7-1. Initial Screen

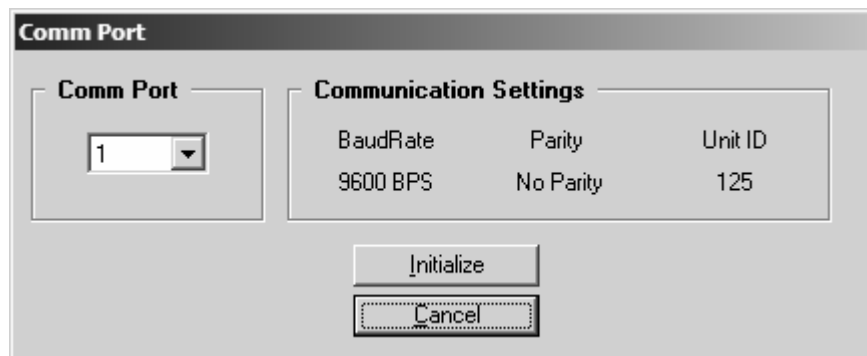

Figure 7-2. Comm Port

This screen shows the currently selected communication parameters if these are correct select the comm port and press the **Initialize** button. If the port is available the Logon Password screen (Figure 7-3) will appear. Type in your password and press OK. If you press Cancel, the communication port will be closed and you will have to initialize communications again. If the communication parameter shown on the Comm Port screen are incorrect see the Section on changing the programs communication parameters.



Figure 7-3. Password

(Note : The default Limited Access password is “DGC” and the default Full Access password is “DGC2000.” Passwords are case sensitive.)

If modem connection was selected after your press initialize the Phone Book screen (Figure 7-4) will appear. From here you can select the name of the unit you want to call. You can also add or delete items in the phone book. After making a selection press the Dial Number button and the modem will dial the select number. After the modem's connect the Logon Password screen (Figure 7-3) will appear. Type in your password and press OK.

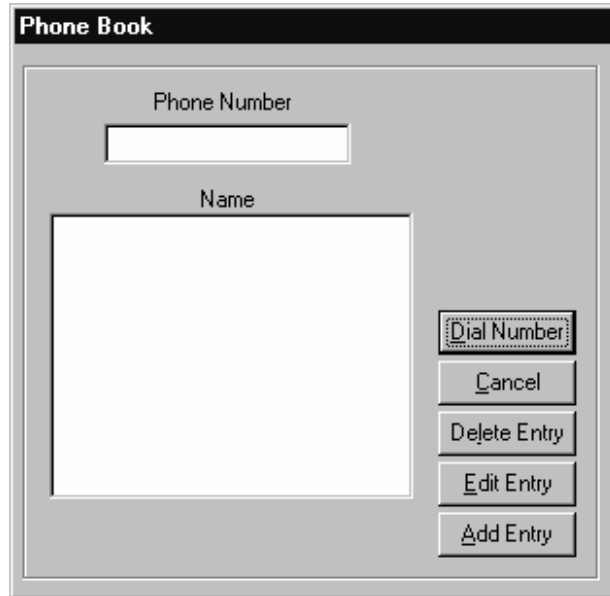

Figure 7-4. Phone Book

CHANGING BESTCOMS COMMUNICATION PARAMETERS

BESTCOMS communication parameters can be changed whether you are logged onto the DGC-2000 or not. To change the communication parameters, pull down the **Configure** menu and select **RS232** this will bring up the screen shown in Figure 7-5. When you are logged onto a unit and change a parameter, by selecting **Save** you are saving the changes both to the PC and to the DGC unit. When not logged on the parameters are only saved to the PC. (Note : To change the communications parameters in the DGC you **must** be logged on with the full access password.)

The Modem Time Delay parameter is only available if you are changing the parameters while logged onto a unit. This parameter allows the user to extend the standard 3.5 millisecond “no character” timeout (for Modbus) by as much as 10 milliseconds (9999). This extra time is used to compensate for the extra time delays that the modem adds.

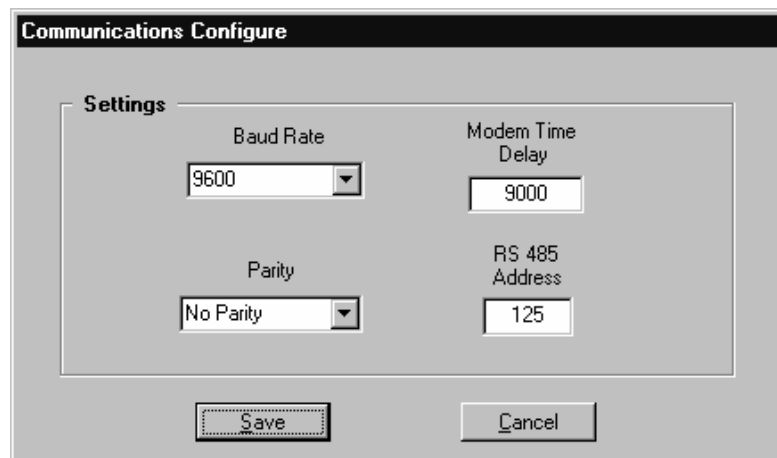

Figure 7-5. Communications Configure Screen

CHANGING LOGON PASSWORDS

To change Logon passwords you must be currently logged onto a DGC unit. Pull down the **Communication** menu and select **Change Password**. When this is done the Change Password (Figure 7-6) screen will appear. There are two option buttons on the top off the screen. Select the level of the password you wish to change. Note : If you logged in with the limited access password you are only allowed to change the limited access password. Enter the new password in the first text box and repeat it again in the bottom text box. After entering the new password press the OK button, if both passwords you entered match, the new password will be sent to the DGC. (Note : Passwords are case sensitive)



Figure 7-6. Change Password

REMOTE START AND STOP OF GENERATOR

The DGC must be in Auto for this function to be enabled. When selected the screen in Figure 7-7 is displayed. To start the generator press the start button, this brings up the screen in Figure 7-8 which shows the status of the start operation. The start operation can be canceled by pressing the **Cancel** button. After the starting process is complete the Remote Starting screen will come back up. To exit press the **Cancel** button. To stop the generator press the **Stop** button. If successful a message box will be displayed.



Figure 7-7. Remote Starting

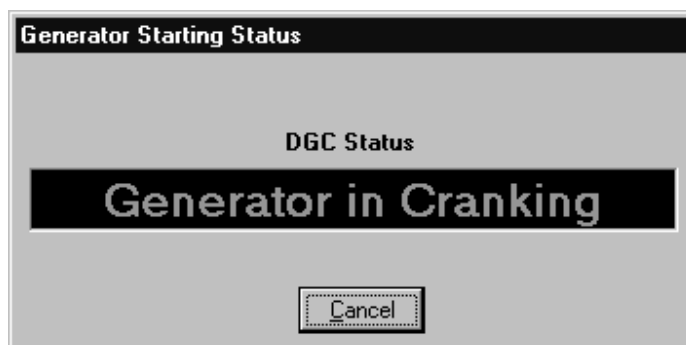

Figure 7-8. Starting Status

CHANGING SETTINGS

Settings are arranged in five groups.

- Sensing Transformers
- Pre-Alarms
- Alarm
- Crank
- System

To change settings, you must first select the screen associated with the setting. When you are logged on with the limited access password you can see all of the current settings in the unit but cannot change all of them. The settings that can not be changed will be disabled so that you can not select them. Double clicking on any white rectangular box will allow you to change (if allowed) that setting. Once all of the settings have been entered, pull down the **Communications** menu and select **Send to DGC**, this will send the settings to the DGC and verify them.

MENUS

File Menu

- 1) **O**pen - Opens a saved settings file from a disk.
- 2) **S**ave - Saves the current settings to a file on a disk. The file will be saved with the extension .dgc.
- 3) **P**rint - Used to print a hard copy of the settings file.
- 4) **E**xit - Used to exit the program.

Communications Menu

- 1) **O**pen - Used to initiate communications with the DGC2000.
- 2) **C**lose - Used to terminate communications with the DGC2000.
- 3) **S**end to **DGC** - Used to send the settings to the DGC2000.
- 4) **G**et from **DGC** - Used to retrieve the present settings from the DGC2000.
- 5) **C**hange **P**assword - Used to change the logon passwords. The current level of access determines which passwords may be changed.
- 6) **R**emote **S**tart/**S**top - Used to start and stop the engine when the DGC2000 is in AUTO.

Screens Menu

- 1) **S**ensing **T**ransformers - Used to program the sensing transformer ratings.
- 2) **P**re-**A**larms - Used to program pre-alarm settings.
- 3) **A**larm - Used to program alarm settings.
- 4) **C**rank - Used to program engine cranking settings.
- 5) **S**ystem - Used to program system parameters.
- 6) **M**eter - Used to display measured quantities. Metering must be enabled to view the measured quantities.

Configure Menu

- 1) **R**S232 - Used to program communication settings.
- 2) **S**ensor **C**urve - *Future addition.*

Help Menu

1) **About** - Displays current software version number.

SETTINGS DEFINITIONS

Definitions for all of the available settings are provided in the following paragraphs.

Sensing Transformers Settings

Refer to Figure 7-9 for the Sensing Transformers Settings definitions.

Generator PT Primary Volts - Rating of the primary side of transformer used to sense generator voltage.

Generator PT Secondary Volts - Rating of secondary side of transformer used to sense generator voltage.

Generator CT Primary Amps - Rating of primary side of transformer used to sense generator current.

Bus PT Primary Volts - Rating of primary side of transformer used to sense bus voltage.

Bus PT Secondary Volts - Rating of secondary side of transformer used to sense bus voltage.

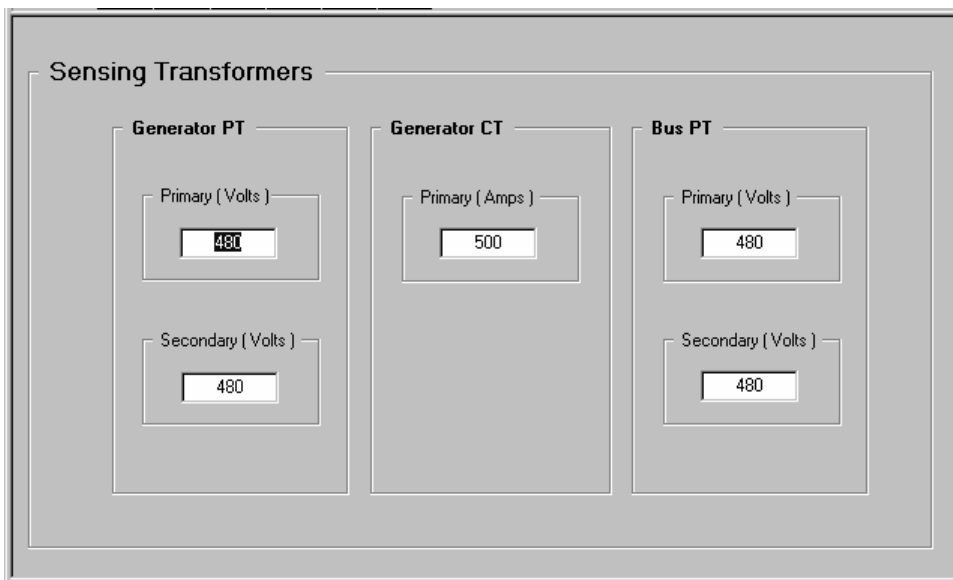

Figure 7-9. Sensing Transformers Screen

Pre-Alarm Settings - Low Fuel - Low Cool - Batt. OverVolt.

Refer to Figure 7-10 for the Pre-Alarm Settings - Low Fuel - Low Cool - Batt. OverVolt. definitions.

Low Fuel Pre-Alarm

- 1) Enable - Used to enable or disable the annunciation of the pre-alarm.
- 2) Threshold - Pre-Alarm will sound when the fuel level drops below this set level.

Low Cool Temperature Pre-Alarm

- 1) Enable - Used to enable or disable the annunciation of the pre-alarm.
- 2) Threshold - Pre-Alarm will sound when the coolant temperature falls below this level.

Battery Over Voltage Pre-Alarm

- 1) Enable - Used to enable or disable the annunciation of the pre-alarm.
- 2) Threshold - Non-adjustable. Threshold is 30 volts for a 24 volt system and 15 volts for a 12 volt system.

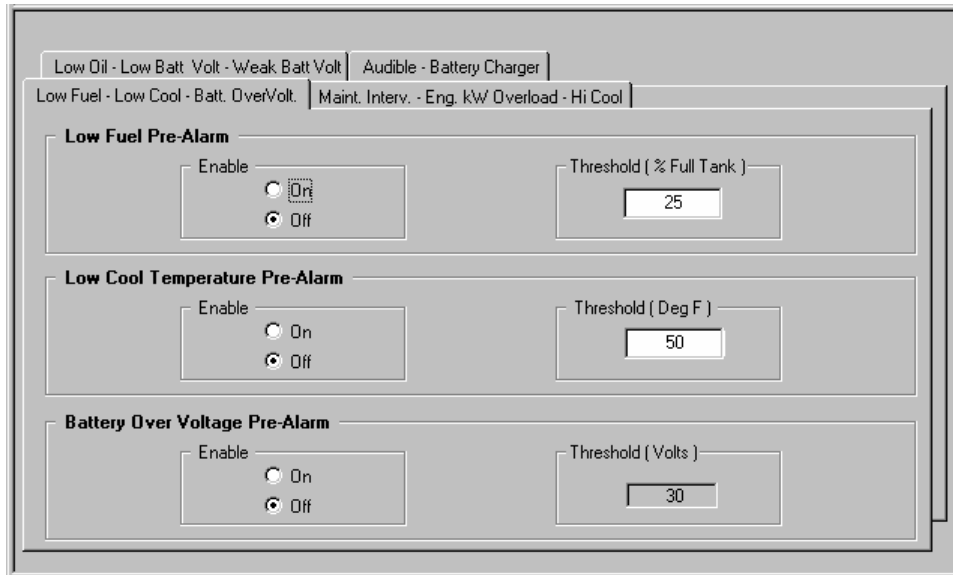

Figure 7-10. Pre-Alarm Settings - Low Fuel - Low Cool - Batt. OverVolt. Screen

Pre-Alarm Settings - Maint. Inter. - Eng. kW Overload - Hi Cool

Refer to Figure 7-11 for the Pre-Alarm Settings - Maint. Inter. - Eng. kW Overload - Hi Cool definitions.

Maintenance Interval Pre-Alarm

- 1) Enable - Used to enable or disable the annunciation of the pre-alarm.
- 2) Threshold - Sets the amount of time in hours that the next maintenance interval is due.

Engine kW Over Load Pre-Alarm

- 1) Enable - Used to enable or disable the annunciation of the pre-alarm.
- 2) Threshold - Sets the kilowatt level for the generator that will sound the pre-alarm.

Hi Coolant Temperature Pre-Alarm

- 1) Enable - Used to enable or disable the annunciation of the pre-alarm.
- 2) Threshold - Pre-Alarm will sound when the coolant temperature rises above this level.

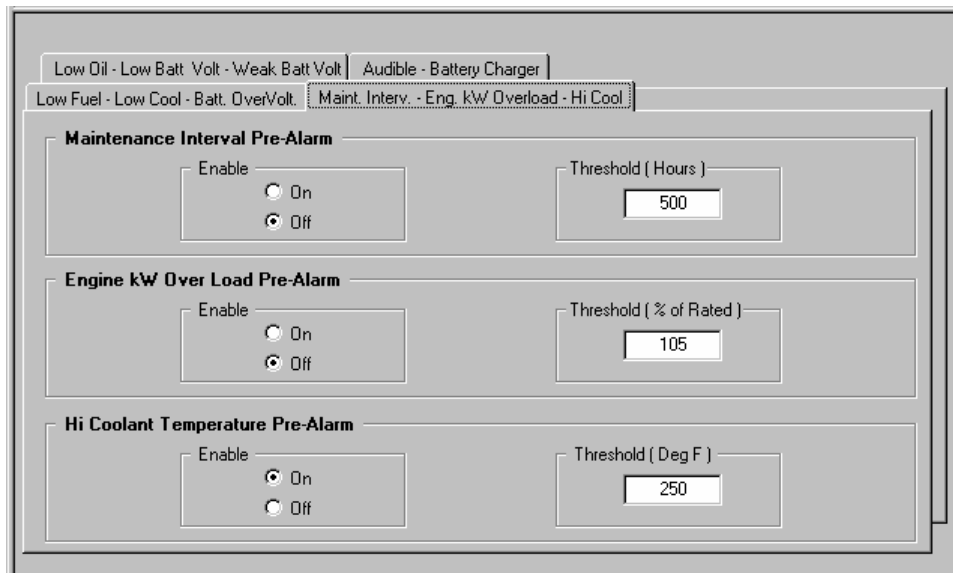

Figure 7-11. Pre-Alarm Settings - Maint. Inter. - Eng. kW Overload - Hi Cool Screen

Pre-Alarm Settings - Low Oil - Low Batt Volt - Weak Batt Volt

Refer to Figure 7-12 for the Pre-Alarm Settings - Low Oil - Low Batt Volt - Weak Batt Volt definitions

Low Oil Pressure Pre-Alarm

- 1) Enable - Used to enable or disable the annunciation of the pre-alarm.
- 2) Threshold - Pre-Alarm will sound when the Oil Pressure falls below this level.

Low Battery Voltage Pre-Alarm

- 1) Enable - Used to enable or disable the annunciation of the pre-alarm.
- 2) Threshold - Pre-Alarm will sound when the Battery Voltage falls below this level.

Weak Battery Voltage Pre-Alarm

- 1) Enable - Used to enable or disable the annunciation of the pre-alarm.
- 2) Threshold - Pre-Alarm will sound when the Battery Voltage falls below this level during cranking. This is a latching type Pre-Alarm and must be reset from the front panel.

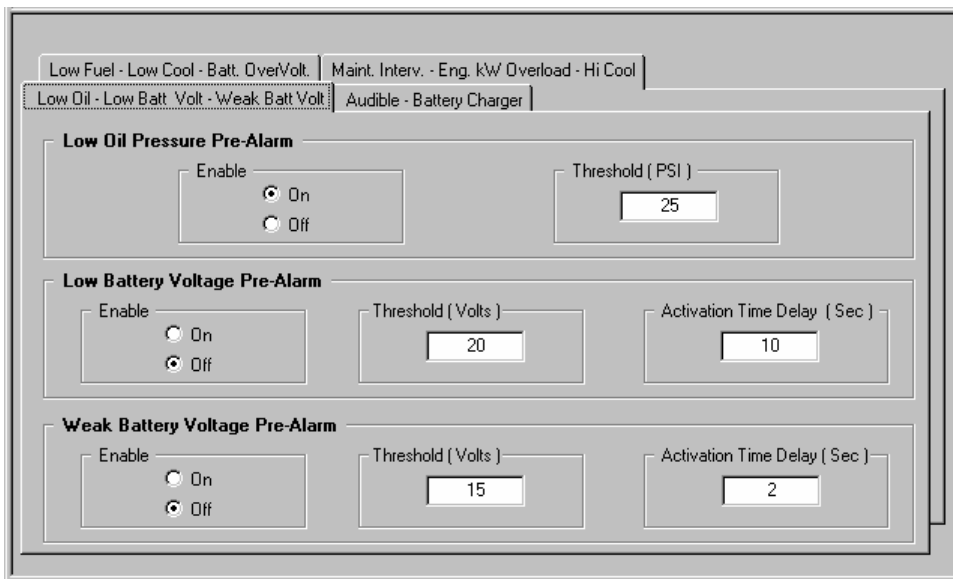

Figure 7-12. Pre-Alarm Settings - Low Oil - Low Batt Volt - Weak Batt Volt Screen

Pre-Alarm Settings - Audible - Battery Charger

Refer to Figure 7-13 for the Pre-Alarm Settings - Audible - Battery Charger definitions.

Audible Alarm

- 1) Enable - Used to enable or disable the horn on the DGC2000.

Battery Charger Failure Pre-Alarm

- 1) Enable - Used to enable or disable the external contact to indicate the battery charger has failed.

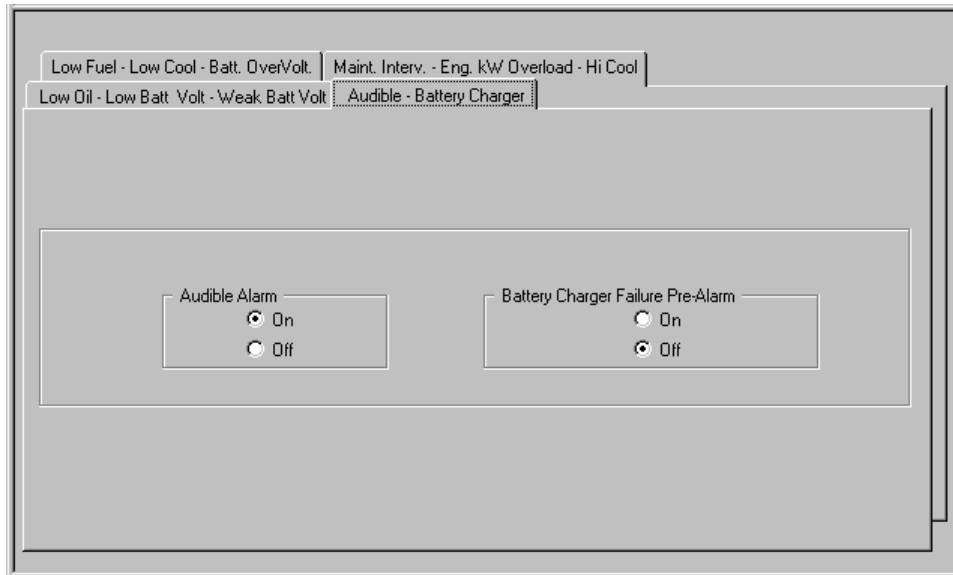

Figure 7-13. Pre-Alarm Settings - Audible - Battery Charger Screen

Alarm Settings - Hi Cool Temp - Low Oil Press

Refer to Figure 7-14 for the Alarm Settings - Hi Cool Temp - Low Oil Press definitions.

Hi Cool Temperature Alarm

- 1) Enable - Used to enable or disable the annunciation of the alarm.
- 2) Threshold - Sets the threshold level for the coolant temperature.
- 3) Arming Delay - Unadjustable - After the coolant temperature is above the threshold for 60 Sec the engine will be shutdown.

Low Oil Pressure Alarm

- 1) Enable - Used to enable or disable the annunciation of the alarm.
- 2) Threshold - Sets the threshold level for low oil pressure before engine shutdown occurs.
- 3) Arming Delay - Sets the amount of time delay, after crank disconnect, before the Oil Pressure Alarm becomes active.

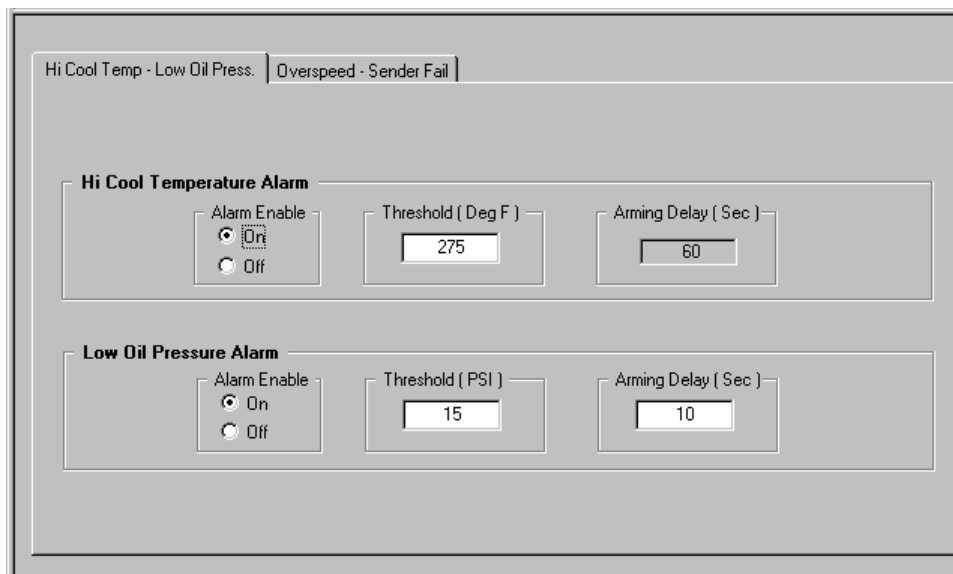

Figure 7-14. Alarm Settings - Hi Cool Temp - Low Oil Press Screen

Alarm Settings - Overspeed - Sender Fail

Refer to Figure 7-15 for the Alarm Settings - Overspeed - Sender Fail definitions.

Overspeed Alarm

- 1) Enable - Used to enable or disable the annunciation of the alarm.
- 2) Threshold - Sets the threshold level for engine speed, before shutdown occurs.
- 3) Alarm Activation - Sets the amount of time the engine speed must be above the threshold before the engine is shutdown.

Sender Failure Alarm

Coolant Temperature Sender:

- 1) Enable - Used to enable or disable the annunciation of the alarm.
- 2) Alarm Delay - Sets the amount of time the signal must be lost before the engine is shutdown.

Oil Pressure, Loss of Generator Voltage and Speed Failure

- 1) Enable - Used to enable or disable the annunciation of the alarm.
- 2) Global Sender Failure Alarm Time Delay - Sets the amount of time any of the signals (Oil Pressure, Loss of Generator Voltage and Speed Sender Failure) must be lost before the engine is shutdown.

Figure 7-15. Alarm Settings - Overspeed - Sender Fail Screen

Crank Settings

Refer to Figure 7-16 for the Crank Settings definitions.

Cranking Style - Used to select the method of cranking.

Crank Disconnect Limit (% of Rated) - Used to select the engine speed above which the cranking process will be terminated.

Pre-Crank Delay (Sec) - Used to select the time between initiating engine start and actual beginning of engine cranking.

Pre-Start Contact After Disconnect - Used to select whether or not the pre-crank contact will remain closed after disconnect occurs.

Number of Crank Cycles - Used to select the number of times the engine may be cranked before an overcrank condition occurs. (Available only if Cycle Cranking is selected.)

Cycle Crank Time (Sec) - Used to select the duration of each crank attempt for cycle cranking.

Continuous Crank Time (Sec) - Used to select the duration of the single crank attempt before an overcrank condition occurs. (Available only if Continuous Cranking is selected.)

The screenshot shows a software interface for configuring engine cranking settings. It is titled 'Crank' and is split into two columns. The left column, under the heading 'Crank', contains four settings: 'Cranking Style' with radio buttons for 'Continuous' (selected) and 'Cycle'; 'Crank Disconnect Limit (% of Rated)' with a text box containing '30'; 'Pre-Crank Delay (Sec)' with a text box containing '0'; and 'Pre-Start Contact After Disconnect' with radio buttons for 'Enable' and 'Disable' (selected). The right column, under the heading 'Cycle', contains three settings: 'Number of Crank Cycles' with a text box containing '2'; 'Cycle Crank Time (Sec)' with a text box containing '5'; and 'Continuous Crank Time (Sec)' with a text box containing '10'.

Figure 7-16. Crank Settings Screen

System Settings

Refer to Figure 7-17 for the System Settings definitions.

Genset's kW Rating - Used to enter the generator's kilowatt load rating.

No Load Cool Down Time - Used to select the time between the generator's load being removed and when the engine actually stops on a remote shutdown.

Rated Engine RPM - Used to enter the engine's rated RPM.

Alternator Frequency Rated (Hz) - Used to select the alternator's rated output frequency.

Battery Volts - Used to select the system's starting battery's nominal voltage.

NFPA Level - Used to select whether or not NFPA requirements are in effect.

Flywheel Teeth - Used to enter the number of teeth on the engines flywheel.

Generator Speed Mode - Used to select which sources are available for calculating engine speed.

Generator Connection - Used to select the generator connection scheme.

Generator Frequency - Used to select the generator's rated output frequency.

Unit System - Used to select English or Metric unit system for PC settings and front panel display on DGC2000.

Generator Rotation - Used to select either ABC or ACB phase rotation.

Embedded Software Version - Shows what version the embedded software on the DGC2000 is. This is only shown for a unit that you are logged onto.

Maintenance Interval Timer Reset - Used to terminate the "Maintenance Due" pre-alarm and reset the maintenance interval timer back to the programmed level. This is done when logged onto a DGC2000 by clicking the box so a check mark is displayed then open the **Communications** menu and select **Send to DGC**. After the command is sent to the DGC the box is then unchecked.

Total kW Hours Reset - used to reset the kilowatt hours to zero. This is done when logged onto a DGC2000 by clicking the box so a check mark is displayed then open the **Communications** menu and select **Send to DGC**. After the command is sent to the DGC the box is then unchecked.

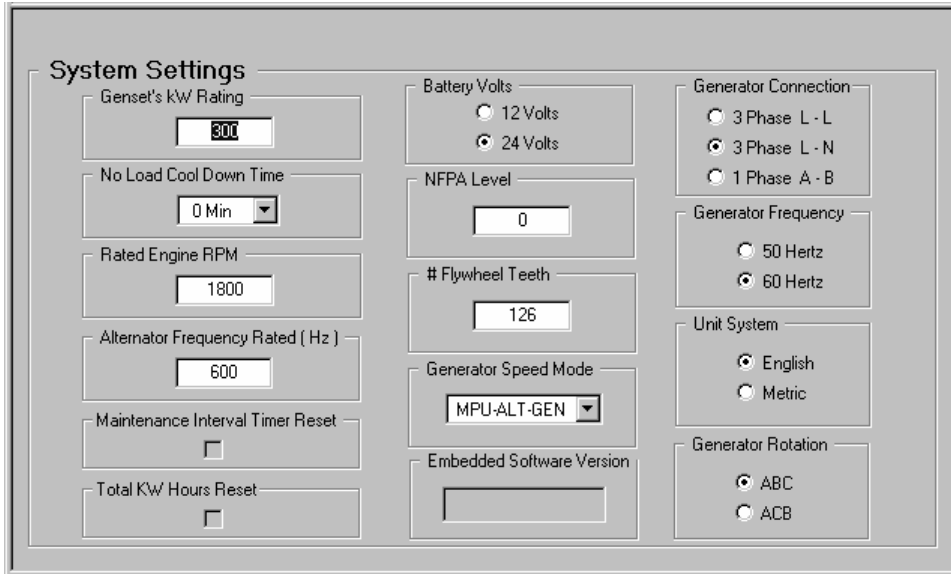

Figure 7-17. System Settings Screen

Metering

BESTCOMS software provides a means to monitor the metering data and alarm status. The metering data and the alarm status are refreshed approximately every 1.5 seconds.

Metering. The metering is separated into six different screens. There is one screen **Summary** that shows all the available metering values from the DGC 2000 (Refer to Figure 7-18). The other five screens have a detailed subset of these metering values available. To enable metering you must be logged onto a unit and then open the **Metering** menu and select enable metering. If you are not on the metering screen the program will change to the metering screen and start updating the values. When metering is disabled all of the metering screens will be grayed out showing they are inactive.

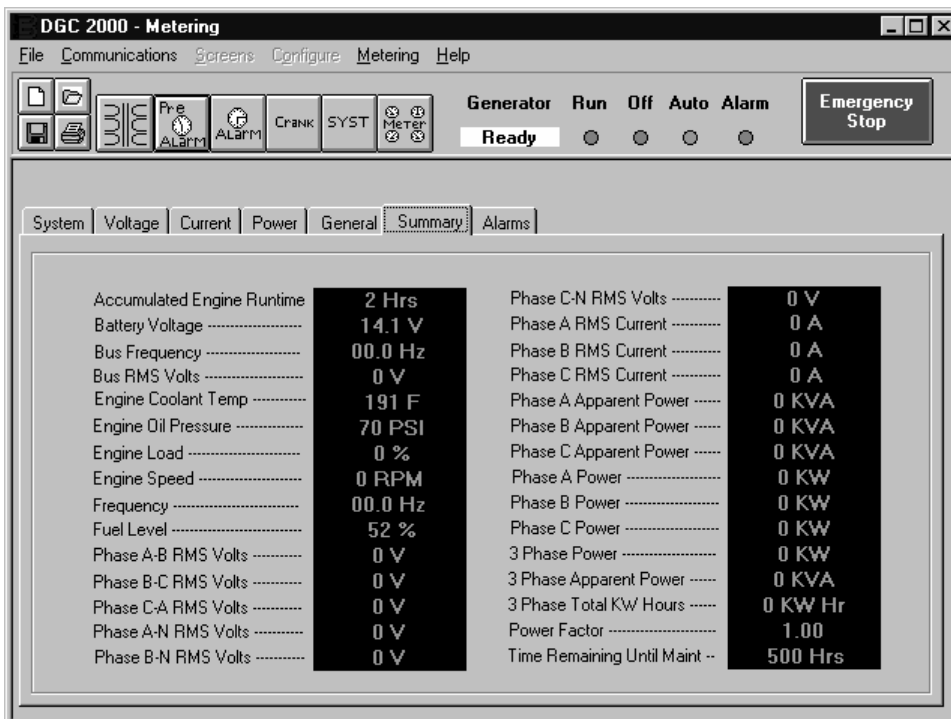

Figure 7-18. Metering Screen

Alarms. The pre-alarms and alarms are all shown on one screen (refer to Figure 7-19). When a pre-alarm becomes active the LED next to the name of the pre-alarm will be green. A description of the alarm will be shown on top of the screen and the computer speaker will begin to beep. The label on top of the screen will contain the same alarm until it goes away and then it will show the next pre-alarm going down the list that is active. When an alarm becomes active the LED next to the name of the alarm will be red. The screen will jump to the alarm tab and the computer speaker will begin to beep. If the alarm type is a Sender Failure the type of sender that failed will be indicated in the Sender Failure type area.

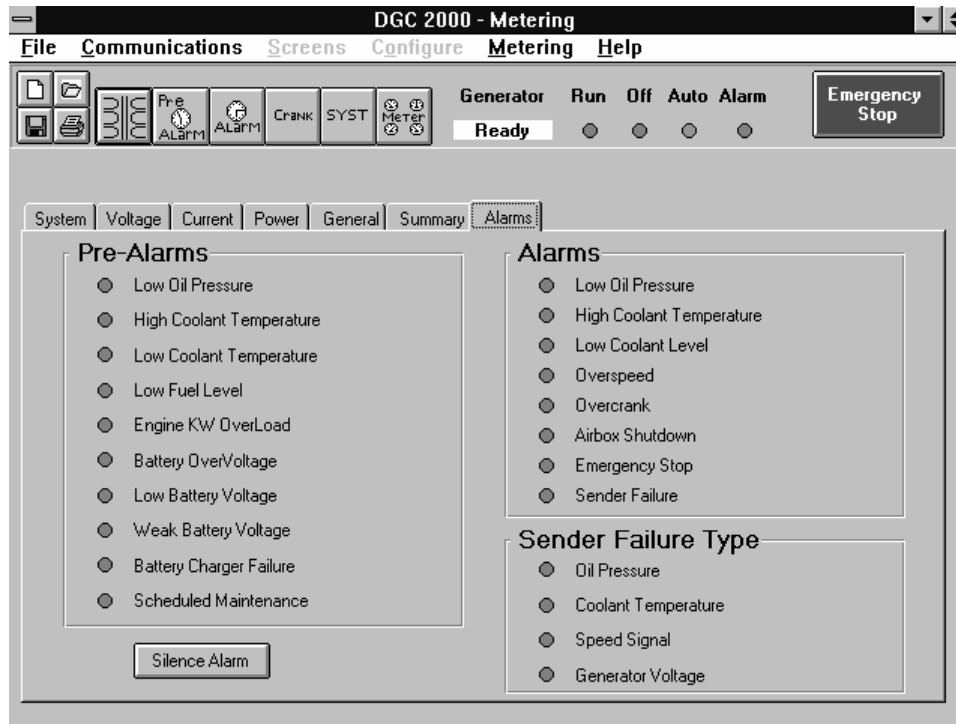

Figure 7-19. Metering - Alarms Screen

Top Portion Of The Screen

This area of the screen contains icon buttons for New File, File Open, Save File, Print File and a button for each screen. Refer to Figure 7-20.

New File - Overwrites the current settings with default settings as a starting point.

File Open - Open a currently saved settings file.

File Save - Saves the settings that are being edited to a settings file.

Print File - Prints a hard copy of the settings.

The Generator Status gives the last received state of the generator if you are logged on. When metering is enabled this is updated continuously along with the other meter readings. When metering is disabled it only checks the generator status when another communication event happens i.e. logon, send settings or get settings).

Emergency Stop button - This button is used to shut the generator down in an emergency. You must be logged onto the DGC for this button to be active. When this button is selected it will change into an *Emergency Reset button*.

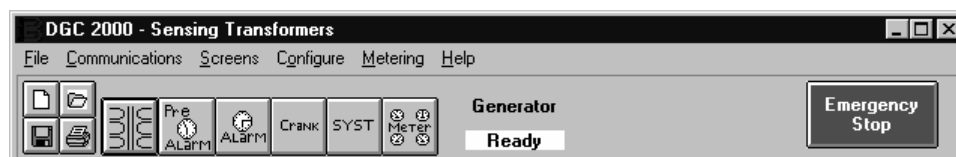

Figure 7-20. Top Portion of Screen

This page intentionally left blank.

APPENDIX A • DGC-2000 SETTINGS RECORD

INTRODUCTION

This appendix provides a complete listing of all DGC-2000 settings. This listing is in the form of a settings record that you may use to record information relative to your system. These settings sheets may be removed and photocopied.

DGC-2000 SETTINGS RECORD

Genset ID _____ Date _____

DGC-2000 Serial Number _____ Software Version Number _____

Parameter	User Setting
FREQUENCY	
BATTERY VOLTAGE	
UNITS	
NFPA LEVEL	
SENSING CONNECTION	
PARITY	
BAUD RATE	
ADDRESS	
GENERATOR PT PRIMARY	
GENERATOR PT SECONDARY	
GENERATOR CT PRIMARY	
BUS PT PRIMARY	
BUS PT SECONDARY	
FLYWHEEL TEETH	
RATED RPM	
COOLDOWN TIME	
GENERATOR RATING	
ALTERNATOR FREQUENCY	
SPEED SIGNAL SOURCE	
PHASE ROTATION	
OVERSPEED ALARM	
THRESHOLD	
DELAY	
HIGH COOLANT TEMP	
ALARM	
THRESHOLD	
DELAY	
HIGH COOLANT TEMP	
PRE-ALARM	

Parameter	User Setting
THRESHOLD	
ARMING DELAY	
LOW OIL PRESSURE	
ALARM	
THRESHOLD	
ARMING DELAY	
LOW OIL PRESSURE	
PRE-ALARM	
THRESHOLD	
ARMING DELAY	
LOW COOLANT TEMPERATURE	
PRE-ALARM	
THRESHOLD	
ARMING DELAY	
LOW FUEL LEVEL	
PRE-ALARM	
THRESHOLD	
WEAK BATTERY	
PRE-ALARM	
THRESHOLD	
ACTIVATION DELAY	
LOW BATTERY	
PRE-ALARM	
THRESHOLD	
ACTIVATION DELAY	
BATTERY OVERVOLTAGE	
PRE-ALARM	
THRESHOLD	
BATTERY CHARGER	
FAILURE PRE-ALARM	

Parameter	User Setting
GLOBAL SENDER	
FAILURE ALARM	
ARMING DELAY	
GLOBAL PRE-ALARM	
BUZZER	
MAINTENANCE INTERVAL	
PRE-ALARM	
THRESHOLD	
ENGINE KILOWATT	
OVERLOAD PRE-ALARM	
THRESHOLD	
CRANKING STYLE	
CRANK CYCLES	
CYCLE CRANK TIME	
CONTINUOUS CRANK TIME	
PRE-CRANK DELAY	
PRE-START CONTACT AFTER DISCONNECT	
CRANK DISCONNECT SPEED	
SAFE RESTART SPEED	



ROUTE 143, BOX 269

HIGHLAND, IL 62249 USA

<http://www.basler.com>, info@basler.com

PHONE +1 618-654-2341

FAX +1 618-654-2351