

# INSTRUCTION MANUAL

FOR

MULTIFUNCTION METER SYSTEM

BE1-MMS100

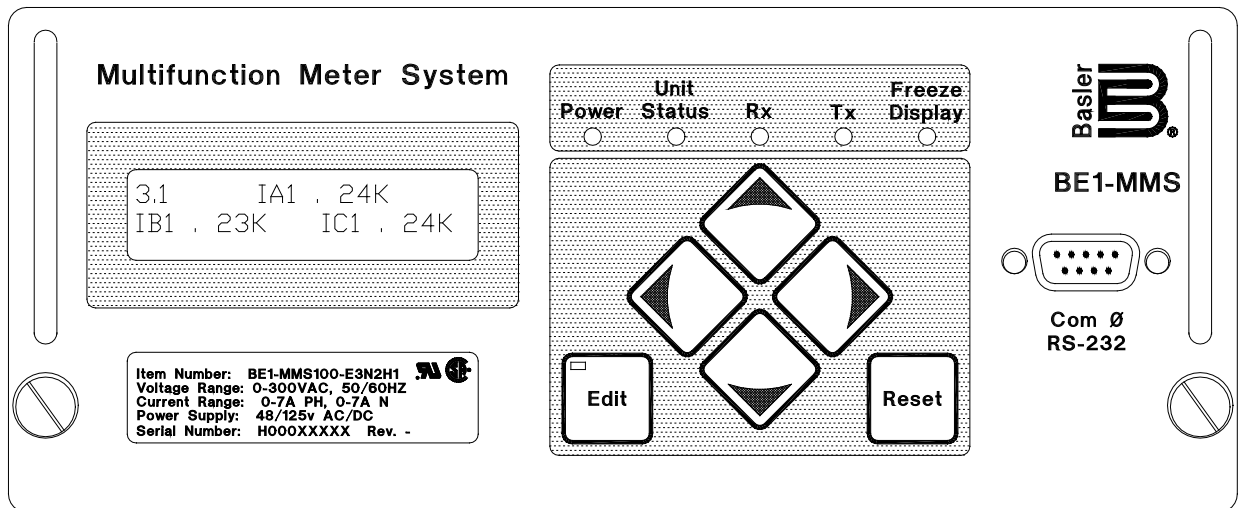

 **Basler Electric**<sup>®</sup>

Publication: 9326700991  
Revision: C 09/17



# INTRODUCTION

This manual provides information concerning the operation and installation of BE1-MMS100, Multifunction Meter System. To accomplish this, the following is provided.

- Specifications
- Human-Machine Interface
- Theory of Operation
- Installation

## **WARNING!**

**TO AVOID PERSONAL INJURY OR EQUIPMENT DAMAGE, ONLY QUALIFIED PERSONNEL SHOULD PERFORM THE PROCEDURES PRESENTED IN THIS MANUAL.**

## **CAUTION**

**MEGGERS AND HIGH POTENTIAL TEST EQUIPMENT SHOULD BE USED WITH EXTREME CARE. INCORRECT USE OF SUCH EQUIPMENT COULD DAMAGE COMPONENTS CONTAINED IN THE DEVICE.**

## **CAUTION**

**THIS PRODUCT CONTAINS ONE OR MORE NONVOLATILE MEMORY DEVICES. NONVOLATILE MEMORY IS USED TO STORE INFORMATION (SUCH AS SETTINGS) THAT NEEDS TO BE PRESERVED WHEN THE PRODUCT IS POWER-CYCLED OR OTHERWISE RESTARTED. ESTABLISHED NONVOLATILE MEMORY TECHNOLOGIES HAVE A PHYSICAL LIMIT ON THE NUMBER OF TIMES THEY CAN BE ERASED AND WRITTEN. IN THIS PRODUCT, THE LIMIT IS 100,000 ERASE/WRITE CYCLES. DURING PRODUCT APPLICATION, CONSIDERATION SHOULD BE GIVEN TO COMMUNICATIONS, LOGIC, AND OTHER FACTORS THAT MAY CAUSE FREQUENT/REPEATED WRITES OF SETTINGS OR OTHER INFORMATION THAT IS RETAINED BY THE PRODUCT. APPLICATIONS THAT RESULT IN SUCH FREQUENT/REPEATED WRITES MAY REDUCE THE USEABLE PRODUCT LIFE AND RESULT IN LOSS OF INFORMATION AND/OR PRODUCT INOPERABILITY.**

First Printing: November 2000

Printed in USA

Copyright © 2017, Basler Electric Co., Highland, IL 62249

September 2017

**CONFIDENTIAL INFORMATION**

OF BASLER ELECTRIC COMPANY, HIGHLAND, IL. IT IS LOANED FOR CONFIDENTIAL USE, SUBJECT TO RETURN ON REQUEST, AND WITH THE MUTUAL UNDERSTANDING THAT IT WILL NOT BE USED IN ANY MANNER DETRIMENTAL TO THE INTEREST OF BASLER ELECTRIC COMPANY.

It is not the intention of this manual to cover all details and variations in equipment, nor does this manual provide data for every possible contingency regarding installation or operation. The availability and design of all features and options are subject to modification without notice. Should further information be required, contact Basler Electric Company, Highland, Illinois.

**BASLER ELECTRIC  
12570 STATE ROUTE 143  
HIGHLAND, IL 62249 USA**

**<http://www.basler.com>, [info@basler.com](mailto:info@basler.com)**

**PHONE 618-654-2341**

**FAX 618-654-2351**

## PRODUCT REVISION HISTORY

The following information provides a historical summary of the changes made to the embedded software (firmware) of this device. The corresponding revisions made to this instruction manual are also summarized. This revision history is separated into four categories: Application Program Firmware Version, BESTCOMS Version, Hardware Version, and Manual Revisions. A manual was published for an early version of the BE1-MMS100, part number 9326700107. BE1-MMS units are no longer produced as part number 932670107. Therefore, all Product History except for the Instruction Manual, refers to the current BE1-MMS100. All changes are listed in reverse chronological order.

Application Program Firmware Version	Change
07.04.00 – Apr 2001	Initial release
BESTCOMS Version	Change
1.01.01 – Apr 2001	Initial release
Hardware Version	Change
Rev None – Apr 2001	Initial release
Manual Revision	Change
C – Sep 2017	Added caution box about nonvolatile memory. Added Storage statement in Section 4. Minor text edits.
B – Nov 2002	Corrected output 6 labeling in Figure 2-2. Normally-closed contact label was changed to normally-open and “ALARM” was changed to “OUT 6”. “Watts” and “Vars” labels in bulleted list on page 3-5 were changed to “Kilowatthours” and “Kilovarhours”. Minor errors throughout manual were corrected.
A – Apr 2001	Corrected the fifth bullet under Features on page 1-1. Deleted ASCII protocol from the Style Chart on page 1-6. Added UL and CSA to Specifications. Changed all drawings showing front overlay/label to reflect changes in the product. Added <i>Harmonics Select</i> to the Menu Tree in Figure 2-3. Changed Harmonic Distortion feature from voltage only to voltage or current selectable. Changed Historical Data Logging on page 3-6. Added Figure 4-3 and raised the number of all following figures in Section 4. Added <i>Product Revision History</i> to the Introduction.
None – Nov 2000	Initial release with BE1-MMS100, 9326700107.



# CONTENTS

---

<b>SECTION 1 • GENERAL INFORMATION.....</b>	<b>1-1</b>
DESCRIPTION.....	1-1
FEATURES.....	1-1
PRIMARY APPLICATIONS.....	1-1
Introduction.....	1-1
Utility Sub-Metering.....	1-1
Utility Substation Automation.....	1-2
Basic Feeder Automation Scheme.....	1-2
Automation Scheme Including New Relays.....	1-3
Automation Scheme With Substation Computers.....	1-4
General Automation System Requirements.....	1-6
MODEL AND STYLE NUMBER.....	1-6
Style Number Example.....	1-6
SPECIFICATIONS.....	1-7
<b>SECTION 2 • HUMAN-MACHINE INTERFACE (CONTROLS AND INDICATORS).....</b>	<b>2-1</b>
GENERAL.....	2-1
FRONT PANEL DISPLAY.....	2-1
MENU TREE.....	2-2
<b>SECTION 3 • FUNCTIONAL DESCRIPTION.....</b>	<b>3-1</b>
INTRODUCTION.....	3-1
SECURITY.....	3-1
INPUT CIRCUITS.....	3-2
Voltage Inputs.....	3-2
Current Inputs.....	3-2
Status Inputs.....	3-2
Power Supply.....	3-4
MICROPROCESSOR.....	3-4
OUTPUT CIRCUITS.....	3-4
Pulse Output Selection Screens.....	3-5
COMMUNICATION.....	3-5
LOGGING AND RECORDING.....	3-6
<b>SECTION 4 • INSTALLATION.....</b>	<b>4-1</b>
GENERAL.....	4-1
MOUNTING.....	4-1
CONNECTIONS.....	4-1
TESTING.....	4-1
COMMUNICATION CONNECTORS AND SETTINGS.....	4-4
Front/Rear RS-232 Connectors.....	4-4
RS-485 Connector.....	4-5
MAINTENANCE.....	4-5
STORAGE.....	4-5
<b>SECTION 5 • TESTING.....</b>	<b>5-1</b>
GENERAL.....	5-1



# SECTION 1 • GENERAL INFORMATION

---

## DESCRIPTION

BE1-MMS100 Multifunction Meter Systems are economical, microprocessor based systems that provide multifunction revenue-accurate power metering, contact status monitoring, and output control functions in an integrated system.

---

## FEATURES

Multifunction Meter Systems have the following features and capabilities.

- Provides accurate metering of voltage, current, watts, vars, and bi-directional energy measurements.
  - Measures individual and total harmonic distortion up to the 31st harmonic.
  - Monitors discrete inputs from utility kWh pulse initiators.
  - Stores Minimum and Maximum Energy Values.
  - Stores 36 days\* of 15 minute average data for volts, amps, watts, vars, power factor, frequency, and accumulated pulse counts, plus values for imported, exported and total kWh, kvarh, and kVAh, and elapsed time since last reset or it stores 12 oscillographic records\* of 21 cycles each at 64 samples per cycle.
  - Monitors the status of input contacts from breakers, targets, switches, etc.
  - Provides control outputs through built-in interposing relays.
    - \* History is limited to 18 days or oscillography is limited to 6 events for the DNP 3.0 option.
- 

## PRIMARY APPLICATIONS

### Introduction

The BE1-MMS100 is ideal for use by utility, industrial, commercial and institutional customers for feeder monitoring and automation, tenant sub-billing, budgetary cost allocation and outage detection. Its unique capabilities make it ideally suited for the following applications:

- Utility sub-metering
- Commercial/Industrial metering
- Substation automation
- Genset applications

And where the following is required:

- A panel meter is needed to read three phase volts, amperes, watts, vars, hertz, watthours or varhours.
- Monitoring of energy utilizing a utility meter's pulse contacts.
- Provisions for output contacts capable of replicating metering pulse contacts.
- Metering data logging and the ability to communicate with a central computer running SCADA software.
- Remote or local interrogation/operation of the metering device.
- High sample oscillographic recording.
- Drawout case construction.

### Utility Sub-Metering

The BE1-MMS100 and a Basler Electric BE1 protective relay can be dovetailed together to form a standard 19-inch rack feeder unit for metering, protection and control. The combination provides the advantage of high metering accuracy that is normally unavailable within protective relays due to their wide dynamic range with the protection required for reliable feeder operation.

## Utility Substation Automation

BE1-MMS100 Systems may be used as panel meters or for metering power contracts, but their most important application is for automating substations. Virtually all substations already have some form of automation. One example is automatic reclosing. Today, we tend to think of substation automation in terms of the capabilities provided by the new generation of intelligent electronic devices (IEDs), programmable logic controllers (PLCs), and computers.

From a practical and cost justifiable viewpoint, substation automation can be viewed in terms of what can be done to improve customer service or reduce costs. Many utilities make the case that customer service can be improved by giving the operator control over breakers in distribution substations. This reduces the number of trips that have to be made to substations and allows service to be restored more rapidly after an outage. Perhaps the biggest cost saving measure is to collect more precise data for planners. Given more accurate data, planners might defer capital expenditures that would otherwise have to be made to be on the safe side of loading estimates.

### Basic Feeder Automation Scheme

This scheme is directed at providing just those functions needed to help planners reduce capital expenditures and help operations minimize trips to substations and reduce outage time. Existing relays are retained and a BE1-MMS100 System is added on each feeder panel as shown in the Figure 1-1. This is referred to as a distributed architecture whereby the BE1-MMS100 System is installed close to the input/output wiring sources. This approach is the least expensive and minimizes hardware and wiring changes.

Feeder current and bus voltage are required for each BE1-MMS100 System. Only three of the available six outputs are needed for trip, close, and enable/disable reclose. The four status inputs are used for reclose status, and breaker status, with two undefined inputs.

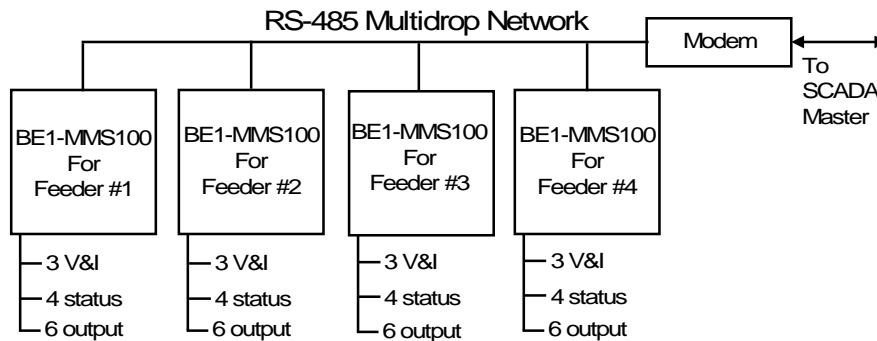

Figure 1-1. Basic Feeder Automation Scheme

This scheme provides the following capabilities:

#### Control Functions

- Trip/close for each feeder breaker
- Disable/enable reclosing relay on each feeder

#### Time Tagged Changes of State

- Breaker position for each feeder (open/closed)
- Reclose status of reclosing relay on each feeder (enabled/disabled)

#### Revenue Accuracy Real-Time Metering

- Bus voltage (average three-phase measurement)
- Current on each feeder
- Kilowatts and kilovars on each feeder

### Planning Data on 36 Day Log at 15 Minute Intervals

- Bus voltage (average three-phase measurement)
- Current on each feeder
- Kilowatts and kilovars on each feeder
- Accumulated kWh and kvarh on each feeder

### Power Quality Data Once a Minute

- Bus voltage harmonics through the 31st on each phase
- Total harmonic distortion in %

### **Automation Scheme Including New Relays**

New feeder relays can be added along with the BE1-MMS100 System to get more detailed fault data and to implement improvements in feeder protection. These are accomplished by adding a Basler Electric BE1-851 or BE1-951 relay on each feeder. The BE1-851 or BE1-951 is the same size as the BE1-MMS100. The two units may be dovetailed together to form one 19-inch wide unit. These units may be flush mounted or mounted in 19 inch racks. The simplest system is shown in Figure 1-2.

The BE1-MMS100 Systems require the same inputs and outputs as shown in the previous paragraphs. The BE1-851 or BE1-951 overcurrent relays require the same current inputs as the BE1-MMS100. The BE1-951 requires the same voltage inputs as the BE1-MMS100. Outputs from the overcurrent relays are for breaker trip, breaker close, and breaker fail. Each relay requires an input for breaker status.

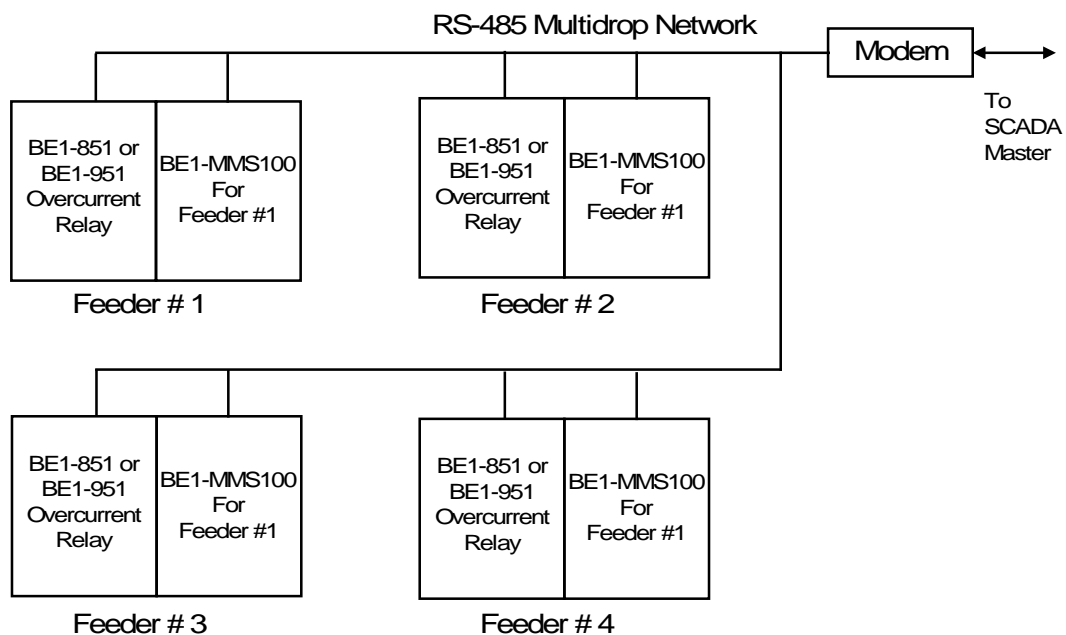

Figure 1-2. Automation Scheme Including New Relays

The additional capabilities provided over and above the previous scheme are as follows:

### Fault Data

- Relay targets
- Three instantaneous overcurrent elements for each feeder
- Three time overcurrent elements for each feeder
- Fault summary reports
- Oscillographic records of fault clearings
- Sequence of events data

### Additional Protective Functions

- Negative sequence overcurrent for more sensitive phase to phase protection
- Four relay setting groups for adapting protection to system conditions
- Coordination with bus relay to achieve feeder relay backup
- Automatic reclosing
- Breaker failure detection

### Maintenance data

- Breaker contact wear data
- Breaker operations counter
- Breaker trip speed monitoring

### Operating Information

- Yesterday's peak demand current
- Today's peak demand current
- Peak demand current since last reset

## Automation Scheme With Substation Computers

A substation computer is a key system element in that it allows intelligence to be moved from the master station to the substation. Moving that intelligence reduces the amount of data that must be communicated between substations and the master station. For example, fault data can be collected at the substation computer and analyzed for fault location. Only the important information is then communicated to the master station. Additional information can be retrieved as needed from databases maintained at the substation. It also provides a way to overcome the need for a standard protocol.

Basler Electric manufactures a hardened PC computer called a BUSI. This stands for Basler Universal Substation Interface. Figure 1-3 shows how the BUSI overcomes the need for a standard protocol through the multi-protocol architecture.

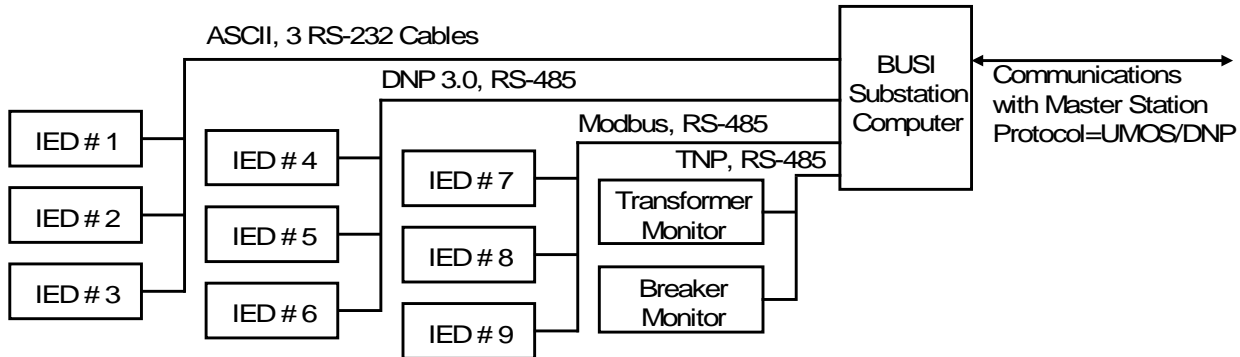

Figure 1-3. Automation Scheme With Substation Computers

Computer software is the heart of the automation scheme with substation computers. Basler's UMOS® application development software has evolved over the past 15 years into an easy to program system running under Windows NT®. The main features of this software as used in the BUSI and master stations are shown in Figure 1-4.

If the optional monitor is employed along with a keyboard, the computer can also serve as the human-machine interface for information and control in the substation.

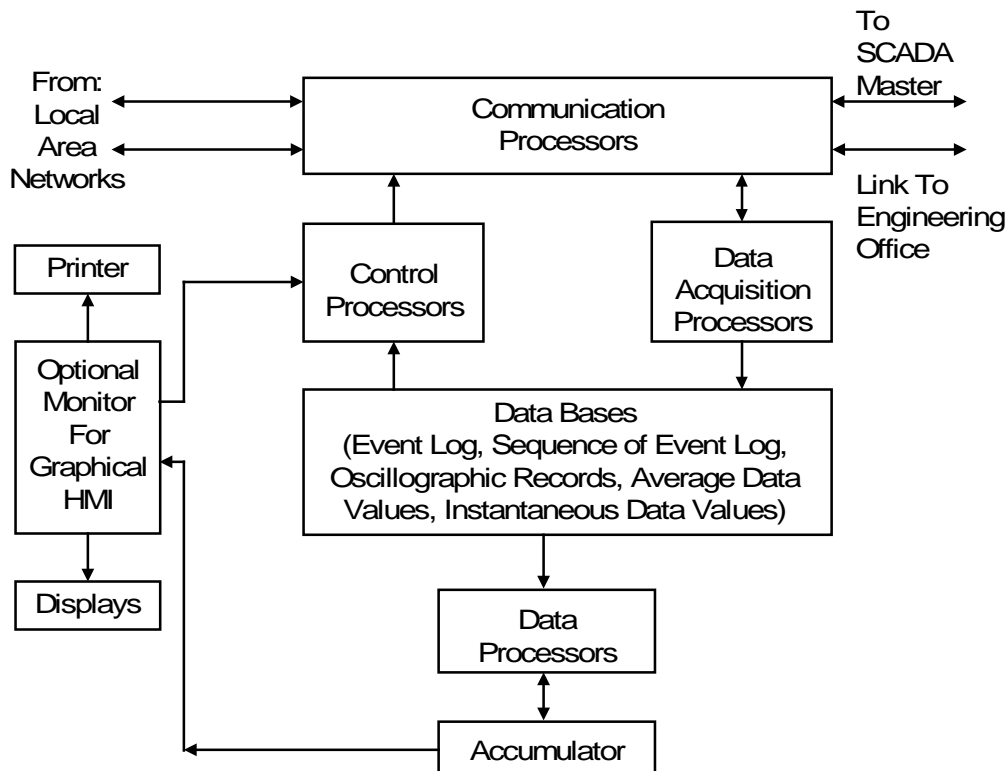
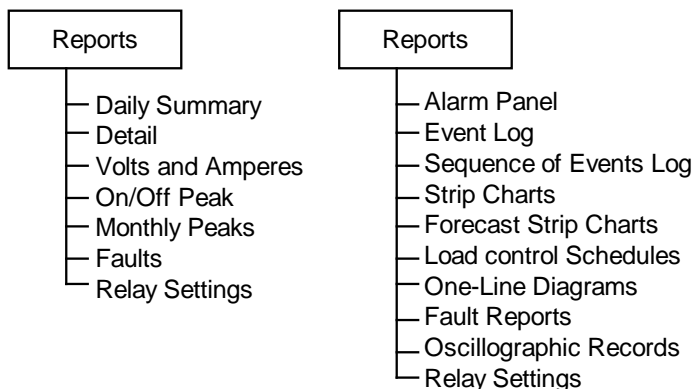

Figure 1-4. UMOS Functionality

Some of the standard reports and screens provided by Basler's UMOS application development software are as follows:



The additional capabilities added by including a computer in the substation are as follows:

Maintains Databases at Substation

- Accumulated demand data.
- Strip chart data for last 365 days

Computer Translates Protocols

- From one protocol to another

Computer can Perform Mathematical Operations on the Data

- Watts and vars may be derived from current and voltage data

Computer Provides Flexibility

- Easy to expand the system or add new functions

### Computer Makes System Easy to Setup and Maintain

- Does not require a programmer to setup UMOS

### Computer can Communicate with more than one master station

- Some systems need links to both Operations and Engineering

### Computer Can Become the Human-Machine Interface in the Substation

- This makes it possible to eliminate manual control switches

## General Automation System Requirements

When specifying general system requirements for an automated system, you should consider the following criteria.

- System should have an open architecture so that it can be adapted to any vendor's hardware.
- System should incorporate a distributed architecture to minimize wiring.
- System should be flexible and easily setup by the user.
- Substation unit should include a computer to store data and pre-process information.
- Should be possible to setup the computer software without requiring a programmer.
- System should communicate with the existing SCADA master with the existing protocol.
- System should be able to handle various communications protocols simultaneously.

---

## MODEL AND STYLE NUMBER

The electrical characteristics and operational features included in the BE1-MMS100 are defined by a combination of letters and numbers that make up the style number. The style number together with the model number describe the features and options in a particular unit and appear on the front panel. Model number BE1-MMS100 designates the relay as a Multifunction Meter System.

### Style Number Example

Figure 1-5 shows the style number identification chart that illustrates the features and options for the Feeder Automation Units. For example, if the style number were **BE1-MMS100 E3N1H3**, the device would have the following features.

#### BE1-MMS100

- (E) - Five ampere nominal system with five ampere independent ground input.
- (3) - Three-phase voltage sensing.
- (N) - Not applicable.
- (1) - 48/125 Vac/Vdc power supply.
- (H) - Half-Rack case.
- (3) - DNP 3.0 Communications.

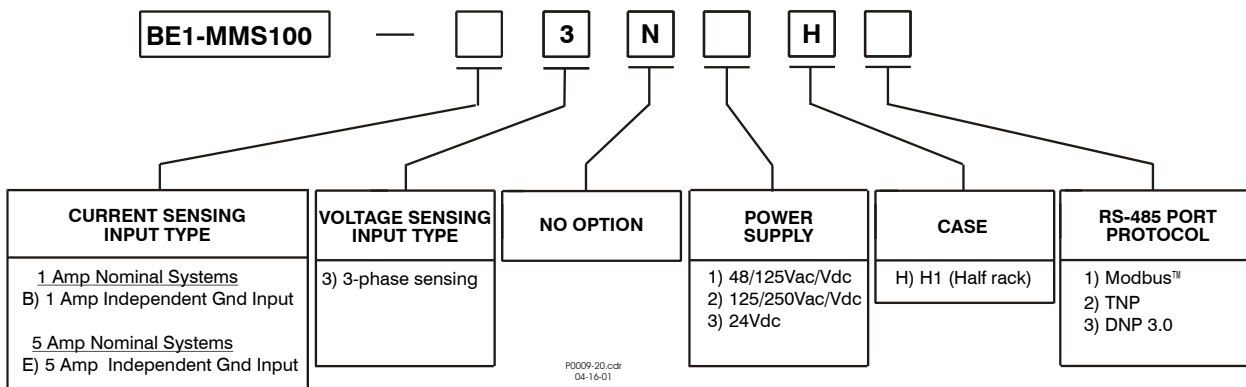

Figure 1-5. BE1-MMS100 System Style Number Identification Chart

---

## SPECIFICATIONS

BE1-MMS100 Systems have the following features and capabilities.

### 5 Amp CURRENT INPUTS

Continuous rating:	20 A
One second Rating:	400 A
Saturation limit:	150 A
Burden:	<10 milliohms

### 1 Amp CURRENT INPUTS

Continuous rating:	4 A
One second rating:	80 A
Saturation limit:	30 A
Burden:	<22 milliohms

### PHASE AC VOLTAGE INPUTS

Continuous rating:	300 V, Line to Line
One second rating:	600 V, Line to Neutral
Burden:	Less than 1 VA @ 300 Vac
Sensing:	4-wire wye, 3 and 2½ elements 3-wire wye, 3 elements 3-wire delta, 2½ and 2 elements

### INPUT RANGES

Voltage:	0 – 300 Vac rms
Current:	0 - 3.0 Aac, 1A CT sec. 0 - 15.0 Aac, 5A CT sec.

### METERING ACCURACY

#### Standards

- Meets or exceeds IEC 60687 – 1992
- Meets or exceeds IEEE C12.20 – 1995

#### At 50.0Hz or 60.0Hz @ 25° C ( $0.1 I_{nom} < I < I_{max}$ )

Voltage:	±0.1% of reading
Current:	±0.1% of reading
Watt (at ±0.8 PF):	±0.2% of reading
Var (at ±0.8 PF):	±0.2% of reading
Maximum Temperature Error:	±.005%, full scale per °C on V and I ±.010%, full scale per °C on W and vars
Power Factor (at ±0.5 PF):	0.55% of reading
Pulse Inputs:	99.999%
Frequency:	±0.01%

### kWh, kvarh, and kVAh MEASUREMENTS

kWh (at ±0.8 PF):	0.2% of reading
kvarh (at ±0.8 PF):	0.2% of reading
kVAh (at ±0.8 PF):	0.2% of reading

### A/D CONVERTER

Sampling Rate:	64/cycle, adjusted to input frequency 10-75 Hz
----------------	---------------------------------------------------

## POWER SUPPLY

Option 1:	DC range 35 – 150 V AC range 55 – 135 V
Option 2:	DC range 90 – 300 V AC range 90 – 270 V
Option 3:	DC range 17 – 32 V
Burden:	6 watts continuous, 8 watts maximum with all outputs energized

## OUTPUT CONTACTS

Contact Current	Operating Voltage	Operational Notes
30 amps	120 Vac	0.2 seconds sustained
10 amps	250 Vac	Continuous
0.3 amps	250 Vdc	Break/Switched
10 amps	30 Vdc	Continuous

## CONTROL INPUTS

Wetting voltage range:	DC voltage same as control power supply option.
Nominal Turn On/Off Voltage:	P.S. Option 1: 33 Vdc P.S. Option 2: 83 Vdc P.S. Option 3: 16 Vdc
Burden:	P.S. Option 1: 36 k $\Omega$ P.S. Option 2: 94 k $\Omega$ P.S. Option 3: 15 k $\Omega$

## COMMUNICATION PORTS

Baud rate:	300 - 19200
------------	-------------

## IRIG

Supports IRIG Standard 200-98, format B002.

Input signal: Demodulated (dc level-shifted digital signal)

Logic-High Voltage:	3.5 Vdc, minimum
Logic-Low Voltage:	0.5 Vdc maximum
Voltage Range:	-10 to +10 Vdc
Resistance:	Non-linear, approximately 4 k $\Omega$ at 3.5 Vdc, approximately 3 W at 20 Vdc

## UL RECOGNIZED

UL recognized per Standard 508, UL File Number E97033. Note: Output contacts are not UL recognized for voltages greater than 250 V

## CSA CERTIFIED

CSA certified per Standard CAN/CSA-C22.2 Number 14-M91, CSA File Number LR23131. Note: Output contacts are not CSA certified for voltages greater than 250 V

## DIELECTRIC STRENGTH

2000 Vac at 50/60 Hz in accordance with IEEE C37.90 and IEC 255-5

## SURGE WITHSTAND

Qualified to IEEE C37.90.1-1989

## FAST TRANSIENT

Qualified to IEEE C37.90.1-1989

**RADIO FREQUENCY INTERFERENCE (RFI)**

Qualified to IEEE C37.90.2-1995

**ELECTRO STATIC DISCHARGE (ESD)**

Qualified to European Norm standard EN61000-4-2

**ENVIRONMENT**

Operating temperature range: -40°C to +70°C, (-40°F to +158°F)

Storage temperature range: -40°C to +80°C, (-40°F to 168°F)

Humidity: Qualified to IEC 68-2-38, 1st Edition 1974, Basic Environmental Test Procedures, Part 2:

Test Z/AD: Composite Temperature Humidity Cyclic Test

Note: LCD Display is inoperative below -20°C.

**VIBRATION / SEISMIC**

Qualified to IEC255-21-1, Class 1

**SHOCK**

Qualified to IEC255-21-2, Class 1

**H1 CASE SIZE (Width by Height by Depth)**

10.50" by 3.47" by 9.10" (266.7 mm by 88.1 mm by 231.1 mm) with mounting flanges

10.50" by 3.47" by 8.5" (266.7 mm x 88.1 mm x 215.9 mm) without mounting flanges

**SHIPPING WEIGHT**

H1: Approx. 10 lb (4.54 kg)

**WARRANTY**

Seven years



# SECTION 2 • HUMAN-MACHINE INTERFACE (Controls and Indicators)

## GENERAL

This section provides a description of the BE1-MMS100 human machine interface and illustrates the menu tree.

## FRONT PANEL DISPLAY

Figure 2-1 shows the front panel human-machine interface (HMI) for a BE1-MMS100 Multifunction Meter System in the H1 case. The descriptions following Figure 2-1 refer to the callouts in Figure 2-1.

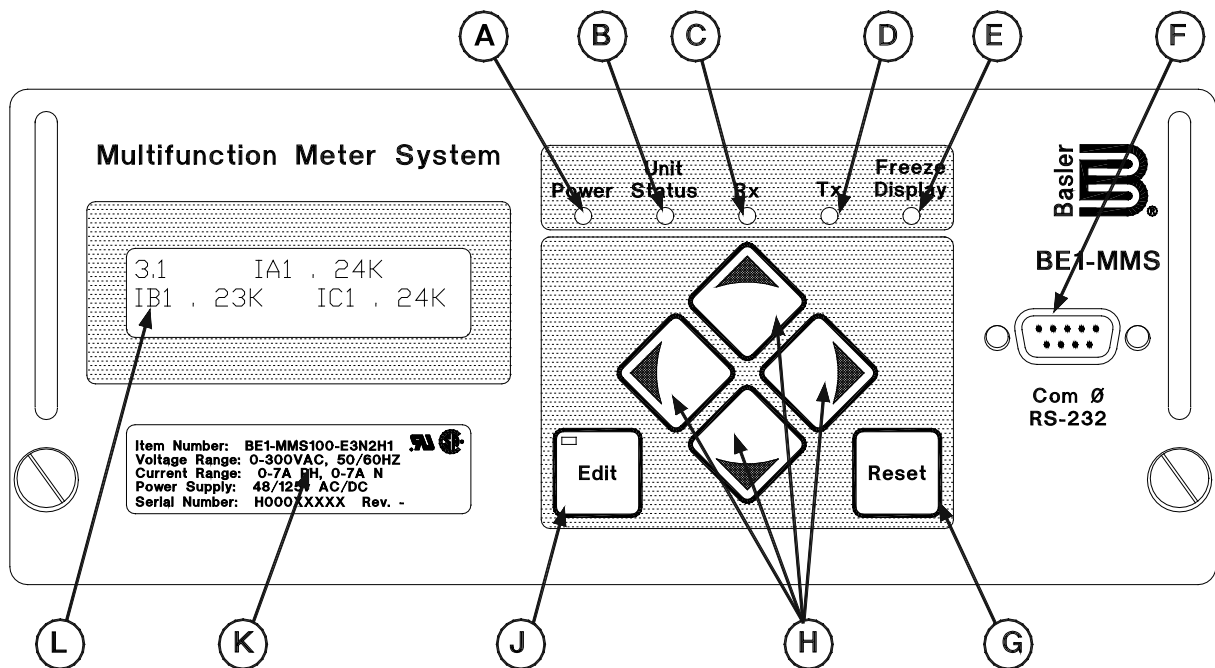

Figure 2-1. BE1-MS100 Multifunction Meter System

Callouts	Description
A	<b>Power LED.</b> When this green LED is ON, indicates operating power is applied and the power supply is operational and within specifications.
B	<b>Unit Status LED.</b> This LED flashes once per second to indicate that the unit is working correctly.
C	<b>Rx LED.</b> This LED flashes when the rear RS-232 port Rx (receive) signal line is high.
D	<b>Tx LED.</b> This LED flashes when the rear RS-232 port Tx (transmit) signal line is high.
E	<b>Freeze Display LED.</b> When this LED is ON, indicates that the display is frozen.
F	<b>Communications Port 0. RS-232 serial communications port.</b> This port is for maintenance use only. See Figure 2-2 for the location of the rear ports (COM 1, RS-232 and COM 2, RS-485). COM1 is ONLY configured for use with the BESTCOMS for BE1-MMS100 and TNP protocols. COM2 is configured for general use and the serial link protocols.

**Callouts****Description**

- G** **Reset** pushbutton switch. Reset switch resets the time interval for 15 minute averages, the elapsed time indicator, and the accumulated kWh and kvarh. The reset function has a prompt to avoid accidental operation.
- H** Scrolling (arrow) pushbuttons (keys). Scrolls UP/DOWN/LEFT/RIGHT through the menu tree or when in the Edit mode, the LEFT/RIGHT arrow pushbuttons select the variable to change and the UP/DOWN arrow pushbuttons change the variable. Pressing the DOWN arrow pushbutton while the menu is scrolling causes the screen display to freeze and the FREEZE DISPLAY LED to turn ON. Pressing the DOWN arrow pushbutton again causes the screen display to resume scrolling.
- J** **Edit** pushbutton switch. Enables settings changes. When the Edit pushbutton is first pushed, an LED on the pushbutton turns ON to indicate the edit mode is active. When changes are complete (using the scrolling pushbuttons) and the Edit pushbutton is pushed again, the LED turns OFF indicating that the changes are saved. If changes are not completed and saved within five minutes, the edit mode is exited without saving changes. If password protection is active, the edit function is inhibited on most screens unless the password has been entered.
- K** Label showing selected BE1-MMS100 information.
- L** Two line by 16 character LCD display with backlighting. Primary source for viewing status and information or when locally programming settings. Displays metering parameters, communications parameters, and the menu tree steps or branches.

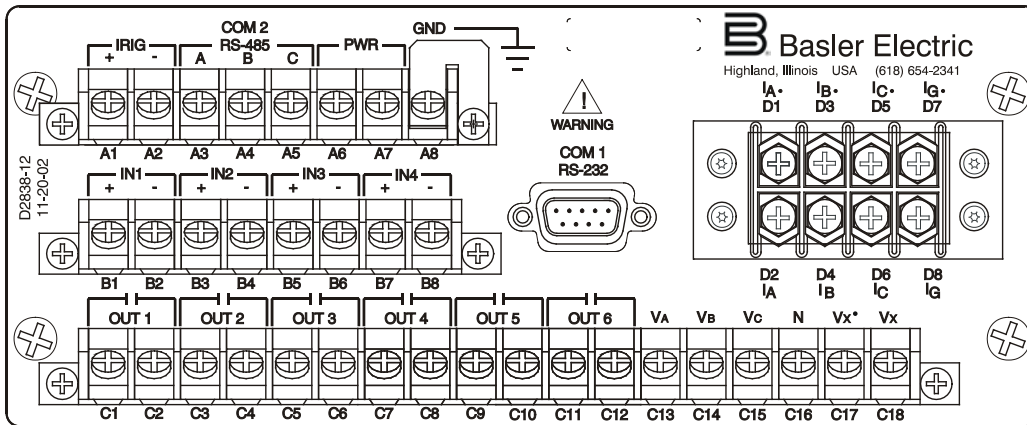

Figure 2-2. BE1-MMS100 Rear View

## MENU TREE

The menu tree has three branches. These branches are:

- **METERING.** Display of real time metering values.
- **DIGITAL READOUTS.** Display of real time pulse input values.
- **GENERAL SETTINGS.** Display and setting of parameters such as communication, meter (ratio) settings, input programming (status or pulse), protocols.

After power on, the BE1-MMS100 display follows the menu tree shown in Figures 2-3 and 2-4. When the accumulated time displays (accumulated time since the last kilowatt-hours reset), you may scroll (using the left and right arrow pushbuttons) through the various metering displays. You may press the up arrow pushbutton from any metering display and return to the main METERING screen. Figure 2-3 shows this path as a dotted line bracketing all of the metering displays and connected with an up arrow to the main METERING screen. Every time that you press the down arrow pushbutton while in the main METERING screen, you will return to the watt-hour and var-hour display. This path is shown as a solid line with a down arrow. All other branch menus are similar.

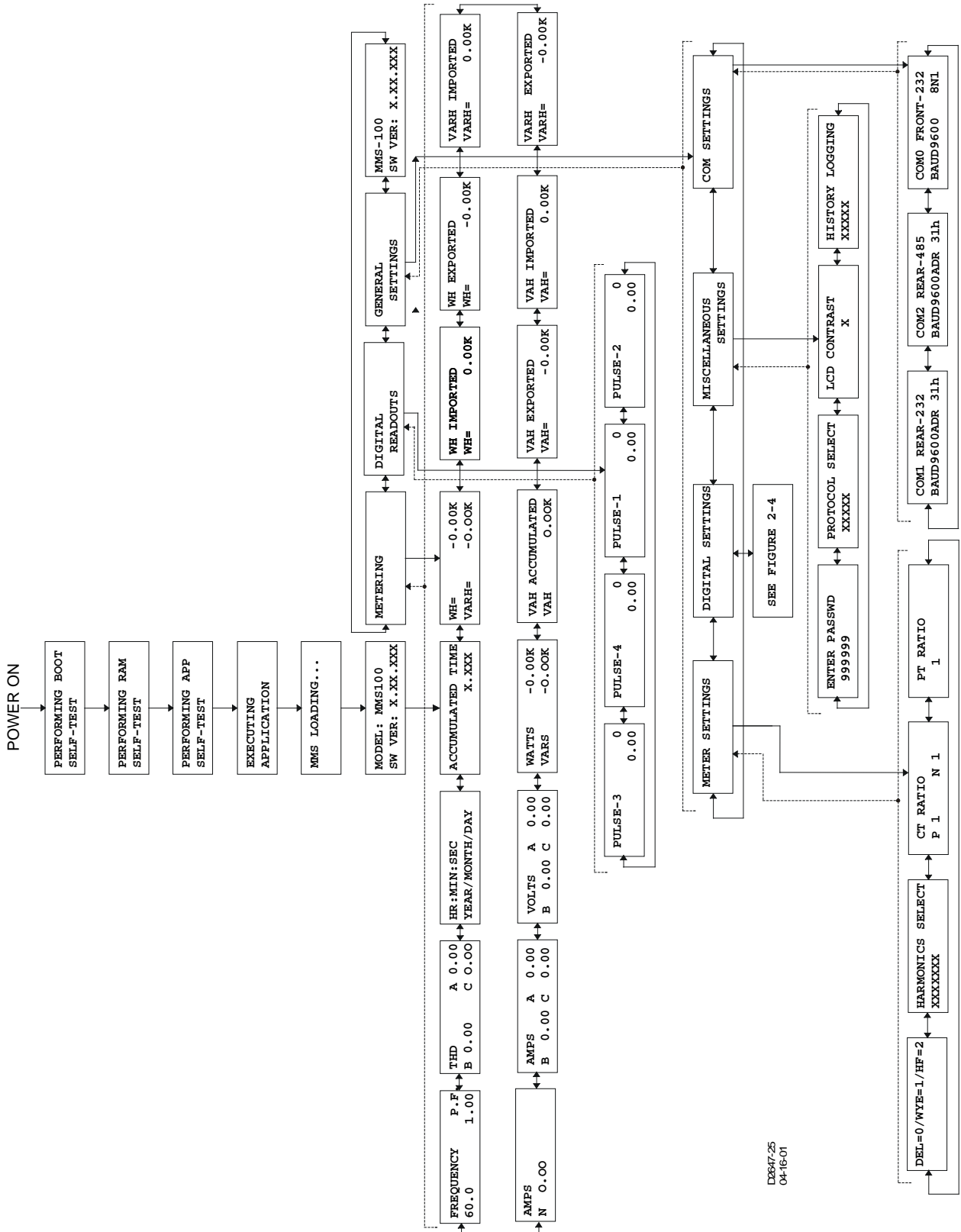

Figure 2-3. BE1-MMS100, Menu Tree

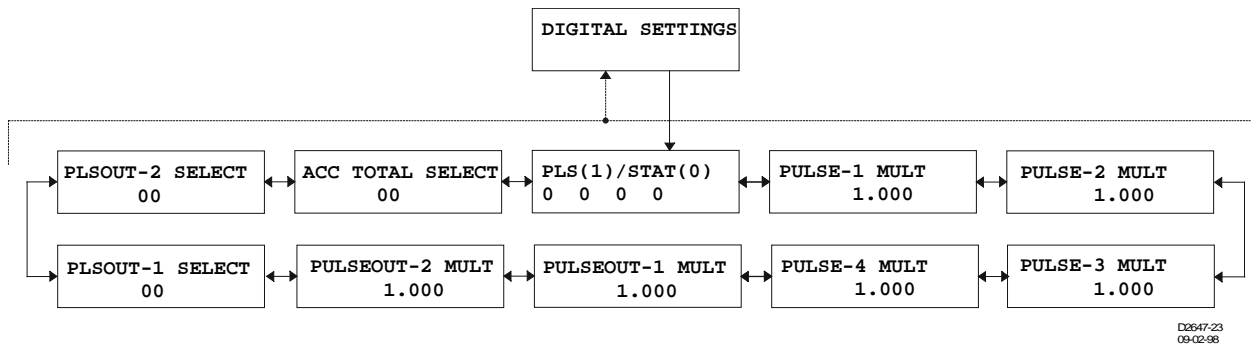

Figure 2-4. BE1-MMS100, Menu Tree, Digital Settings

# SECTION 3 • FUNCTIONAL DESCRIPTION

## INTRODUCTION

Multifunction Meter Systems (BE1-MMS100) are intelligent electronic devices that monitor feeder voltages and currents with revenue accuracy, monitor input contacts, digitize and store monitored data, report status through communications, and provide control outputs. At the heart of these units is the microprocessor which operates under programmable memory control. Monitored inputs are digitized and evaluated by the microprocessor. When appropriate, the microprocessor turns LEDs on or off, information is displayed on the front panel, and output contacts are operated. The following paragraphs provide a functional description of security (password), the input circuits, microprocessor, and the output circuits. Communication is both an input and an output and is described separately. See Figure 3-1 for a simplified block diagram of these circuits.

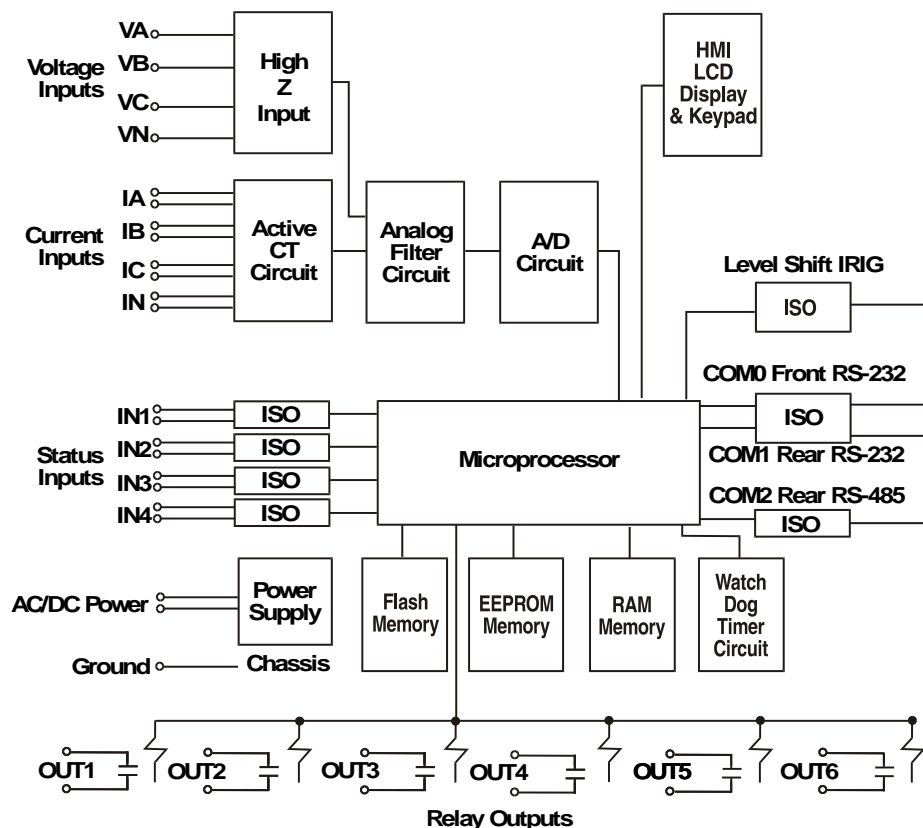

Figure 3-1. Simplified Block Diagram

## SECURITY

Password security uses a six digit, numeric password. This security is intended to prevent casual changes and not provide high-security protection. BE1-MMS100 Systems are delivered with password protection disabled. With password security disabled, all front panel functions operate normally.

Passwords may be set using the front panel HMI or through the serial port using the command **SG-PSWD=n**. Any value of n from 1 to 999998 may be used as the password. When n=0, password security is disabled. Value 999999 is reserved as the initial display for the enter password screen.

If password security is enabled, any attempt to use the Edit function to change settings results in a password required message. You must scroll to the ENTER PASSWORD screen, press the Edit pushbutton (LED turns ON), enter the correct password, and then press the Edit pushbutton again (LED turns OFF). If you entered the correct password, you have approximately five minutes to make changes before the password times out. After password time-out, you must enter the password again to make additional changes.

---

## INPUT CIRCUITS

Each voltage and current input channel is sampled 64 times each cycle. Table 3-1 provides a list of all input signals and calculated data items, a description of each, the interval at which the data items are logged, and availability for alarms and displays. A voltage or current channel includes the antialiasing filters and the analog-to-digital converters (ADC). Antialiasing filters are low pass filters with a cutoff frequency of 1900 hertz. These filters prevent erroneous readings when the inputs contain frequencies higher than one-half the sample rate.

Rms values of the voltage and current inputs are calculated by deriving the root-mean-square value for the samples taken over a one cycle interval. Watts are calculated by multiplying each current sample times the corresponding voltage sample and then averaging all of the obtained values. Vars are calculated by shifting the current samples 90 degrees and then multiplying each current sample times the corresponding voltage sample and then averaging all of the obtained values.

Sampled voltage data are transformed using a Fast Fourier Transform to convert sampled analog data (up to the thirty-first harmonic of the nominal frequency) into phasors. Values for the total harmonic distortion and each phasor are available once a minute via the rear communication (LAN) ports. New data vectors containing voltage, current, and relative phase angle for voltage-current pairs are available at the communication (LAN) ports once per second. Kilowatts, kilovars, and frequency data are also available once per second. This data can be displayed on the front panel and updated once per second. This data is stored in flash memory.

### Voltage Inputs

Voltage inputs are processed as either phase-to-neutral (wye) or phase-to-phase (delta) inputs. These inputs are configured from the front panel or through the communication (LAN) ports. Voltage inputs are applied to high impedance differential circuits with 1.4 megohms impedance on each input. With no transformer in the input, the circuit is free from phase shifts that could cause errors in the power measurements. Each voltage input is sampled 64 times a cycle, filtered by the antialiasing circuits, converted from analog values to digital values, and applied to the microprocessor.

### Current Inputs

Current inputs employ active zero-flux current transformers with negligible phase shift in each input circuit. Each input circuit is completely isolated. Outputs from the current input circuits are also sampled 64 times a cycle, filtered by the antialiasing circuits, converted from analog values to digital values, and applied to the microprocessor.

### Status Inputs

Status inputs have optical isolators on each input. These inputs must have the same dc voltage as the power supply to activate the input circuits. Status inputs are sampled once every 10 milliseconds and applied to the microprocessor.

Each status input may be programmed through the front panel or the communication ports as sustained inputs or pulse inputs. Sustained inputs may be used for control and pulse inputs may be used for counting pulses from utility pulse initiators. A debouncing algorithm checks to verify that the contacts remain closed for as least three read cycles before counting the transition as a valid change of state. Up to 20 momentary changes of state on each channel are acceptable with the provision that only the first 10 are stored. When a contact transition event occurs, the BE1-MMS100 sets a status bit in the communication (LAN) port status message. This message or event may then be detected by a master station on the next poll. Pulse rates up to 20 pulses per second are acceptable on each channel. Once a minute, the BE1-MMS100 computes the pulse count and if available, reports the data via the communication (LAN) ports. Once every 15 minutes, the BE1-MMS100 stores in flash memory, the total pulse count for the past interval on a per channel basis. Data is retained for 36 days and is available for downloading to a master station via the communication (LAN) ports.

Table 3-1. Input Signals And Calculated Data

Data Item	Data Description	Interval	Alarm Hi/Lo	Display	Historical	Min	Max	Days
Va	Voltage Input A	1 sec	X	Yes	15 min	X	X	36
Vb	Voltage Input B	1 sec	X	Yes	15 min	X	X	36
Vc	Voltage Input C	1 sec	X	Yes	15 min	X	X	36
Ia	Current Input A	1 sec	X	Yes	15 min	X	X	36
Ib	Current Input B	1 sec	X	Yes	15 min	X	X	36
Ic	Current Input C	1 sec	X	Yes	15 min	X	X	36
In	Current Input Neutral	1 sec	X	Yes	15 min	X	X	36
kWa	Kilowatts phase A pair inputs	1 sec	X		15 min	X	X	36
kWb	Kilowatts phase B pair inputs	1 sec	X		15 min	X	X	36
kWc	Kilowatts phase C pair inputs	1 sec	X		15 min	X	X	36
kW	Kilowatts for feed	1 sec	X	Yes	15 min	X	X	36
kWh Exp	Kilowatt hours - Exported	1 min		Yes	Total	X	X	36
kWh Imp	Kilowatt hours - Imported	1 min		Yes	Total	X	X	36
kWh Tot	Kilowatt hours - Accumulated	1 min		Yes	Total	X	X	36
kVARa	Kilovars phase A pair inputs	1 sec	X		15 min	X	X	36
kVARb	Kilovars phase B pair inputs	1 sec	X		15 min	X	X	36
kVARc	Kilovars phase C pair inputs	1 sec	X		15 min	X	X	36
kVAR	kvar for feed	1 sec	X	Yes	15 min	X	X	36
kVARh Exp	kvarhours - Exported	1 min		Yes	Total	X	X	36
kVARh Imp	kvarhours - Imported	1 min		Yes	Total	X	X	36
kVARh Tot	kvarhours - Accumulated	1 min		Yes	Total	X	X	36
KVAh Exp	kVAhours - Exported	1 min		Yes	Total	X	X	36
KVAh Imp	kVAhours - Imported	1 min		Yes	Total	X	X	36
KVAh Tot	kVAhours - accumulated	1 min		Yes	Total	X	X	36
Elaps'd Time	Elapsed time since last RESET	1 sec		Yes	Total	X	X	36
PF	Power Factor	1 sec	X	Yes	15 min			36
Freq	Frequency	1 sec	X	Yes	15 min			36
Phase A	Phase Angle A Pair Input	1 sec						
Phase B	Phase Angle B Pair Input	1 sec						
Phase C	Phase Angle C Pair Input	1 sec						
Pulse Ch 1	Pulse count on channel 1	1 min	X	Yes	15 min			
Pulse Ch 2	Pulse count on channel 2	1 min	X	Yes	15 min			
Pulse Ch 3	Pulse count on channel 3	1 min	X	Yes	15 min			
Pulse Ch 4	Pulse count on channel 4	1 min	X	Yes	15 min			
Status Ch 1	Status Input on Channel 1	1 cycle	X		10 count MCD			
Status Ch 2	Status Input on Channel 2	1 cycle	X		10 count MCD			
Status Ch 3	Status Input on Channel 3	1 cycle	X		10 count MCD			
Status Ch 4	Status Input on Channel 4	1 cycle	X		10 count MCD			
Relay Out 1	Output Relay Contacts Chan 1	On Demand						

Data Item	Data Description	Interval	Alarm Hi/Lo	Display	Historical	Min	Max	Days
Relay Out 2	Output Relay Contacts Chan 2	On Demand						
Relay Out 3	Output Relay Contacts Chan 3	On Demand						
Relay Out 4	Output Relay Contacts Chan 4	On Demand						
Relay Out 5	Output Relay Contacts Chan 5	On Demand						
Relay Out 6	Output Relay Contacts Chan 6	On Demand						
THD% - a	Total Harmonic Distortion Phase A	1 min	X	Yes				
THD% - b	Total Harmonic Distortion Phase B	1 min	X	Yes				
THD% - c	Total Harmonic Distortion Phase C	1 min	X	Yes				
Fund - a	Phase A Fundamental	1 min						
Fund - b	Phase B Fundamental	1 min						
Fund - c	Phase C Fundamental	1 min						
Harm n a *	Phase A Harmonic n	1 min						
Harm n b *	Phase B Harmonic n	1 min						
Harm n c *	Phase C Harmonic n	1 min						

\* Where n is a number corresponding to a harmonic from 2 to 31.

Note: History is limited to 18 days for the DNP 3.0 option.

## Power Supply

Operating power for the internal circuitry is applied to the isolated internal switching power supply with a full-wave bridge rectifier on the input. This configuration allows either ac or dc voltage inputs that are not dependent on polarity. Refer to Section 1, *Specifications*, for the required nominal operating power and the functional voltage ranges. The isolated switching power supply generates  $\pm 12$  Vdc, +5 Vdc, and an isolated +5 Vdc.

---

## MICROPROCESSOR

The microprocessor is the heart of the BE1-MMS100 System and performs all control, computation, self test, and communication functions. A watchdog System operating software is stored in non-volatile flash memory. Flash memory can be reprogrammed while it is in the unit by uploading the new system operating software using a computer and the front communication port. BE1-MMS100 System settings and status are stored in non-volatile electrically erasable, programmable, read-only memory (EEPROM). Random access memory (RAM) is high speed, volatile memory that is used for scratch pad or temporary data storage during calculations.

A block of flash memory is also used to store 36 days of recorded data or 12 oscillographic records. The data stored also includes time and date stamps. The time and date system operates without any assistance from an operator. The time setting and synchronization is done over the communication link between the BE1-MMS100 System and a master PC running software such as Basler® Electric UMOS®. Details are available to users that want to communicate using a different communication protocol.

---

## OUTPUT CIRCUITS

Six Form A outputs are provided. These outputs are controlled through the communications ports and sustain 10 amperes at 250 Vac. Each output relay has 300 volt surge protectors across the contacts to protect against arcing from inductive loads. Refer to Section 1, *Specifications* for details. Each output relay may be operated via the communication (LAN) ports using a select and operate sequence. Security to protect against unauthorized operation must be provided in the master station communication software.

Two outputs can be designated as pulse outputs. The maximum pulse rate is 30 pulses per minute for these outputs. Pulse outputs can be set to represent any of the following:

- Kilowatthours
- Kilovarhours
- Pulse in 1
- Pulse in 2
- Pulse in 3
- Pulse in 4
- Any combination of the above outputs

### Pulse Output Selection Screens

Pulse output selection screens (refer to Figure 2-4), allow the user to select a combination of inputs that are added together to provide the particular output. All three of these screens use the same selection scheme in which two binary digits are entered on the screen and used to create a bitmask. In each case, a one in the bitmask means that the microprocessor is to use this input and a zero means don't use this input. Figure 3-2 shows the screen representation for a specific bitmask. Table 3-1 provides the bit description.

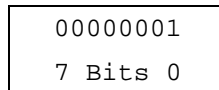

Figure 3-2. Screen Bitmap

Table 3-1. BIT Descriptions

Bit	Description
0	Value from UMOS (or other host system). Normally not used with other input combinations.
1	Kilowatthours (analog value from voltage and current inputs)
2	Kilovarhours (analog value from voltage and current inputs)
3	Pulse input from channel 1
4	Pulse input from channel 2
5	Pulse input from channel 3
6	Pulse input from channel 4
7	Unused/reserved

---

## COMMUNICATION

Three serial communication ports provide easy access to the BE1-MMS100 System. The front port (COM0) is for maintenance use only and allows personnel to change (upload) new system operating software. Rear ports (either the RS-232 (COM1) or the RS-485 (COM2)) provide the user with a choice of interfaces. The user makes this choice using the HMI setup procedures.

There are also three data acquisition and control protocol formats available through the front panel or via the communication (LAN) ports. These formats are transducer network protocol (TNP) (TNP is backward compatible with old ET), Modbus®, and distributed network protocol (DNP). The user makes this choice using the HMI setup procedures.

The communication ports support an 8,N,1 byte format and connect at the following baud rates: 300, 600, 1200, 2400, 4800, 9600, and 19200.

When communicating through the COM0 serial link, you may use ASCII commands. These commands are listed in Table 3-2.

Table 3-2. ASCII Commands

ASCII Command	Description
EXIT	Exit programming mode.
RG-DATE	Reads or changes the date programmed into the real time clock
RG-TIME	Reads or changes the time setting of the real time clock
RG-VER	Reads information about relay hardware/software configurations
SG-COM	Reads or changes the serial communications protocol
SG-FREQ	Reads or changes the nominal power system frequency
SG-LOG	Enables history logging in flash memory
SG-PSWD	Sets the security password

---

## LOGGING AND RECORDING

BE1-MMS100 Systems provide the user with an option of selecting historical data logging or oscillographic recording. This is selected via the front panel HMI. The user can select history, waveform, or off.

Historical data logging logs the following data every fifteen minutes for up to 36 days (historical data is limited to 18 days for the DNP 3.0 option).

- Voltage per phase
- Current per phase
- Watts per phase
- Watts total
- Vars per phase
- Vars total
- Power factor
- Frequency
- Pulse count

It also logs accumulated values since last reset for the following data.

- Imported kWh
- Exported kWh
- Total kWh
- Imported kvarh
- Exported kvarh
- Total kvarh
- Imported kVAh
- Exported kVAh
- Total kVAh
- Elapsed time

Oscillographic recording includes recording 12 events, at 64 samples per cycle. (Events are limited to 6 for the DNP 3.0 option.) After a triggered event, the voltage and current channels are recorded for pre-fault and fault data. Ten cycles of pre-fault data is recorded for a total record length of 21 cycles.

Waveform capture by the BE1-MMS100 may be programmed with up to six concurrent capture criteria. The criteria are combinational logic expressions of the following:

Voltage Criteria. The unit can be programmed to initiate capture when a voltage signal is less than or greater than a set value. Only one of the less than or greater than criteria can be set for one criteria. If no criteria is set, the voltage input is ignored. Both criteria can be defined as unique combinations. That is, if both less than and greater than are present, two of the available six combinational criteria are consumed. The voltage criteria is then applied to all three voltage input channels simultaneously. When the criteria is satisfied on any one of the three channels, waveform capture will occur.

Current Criteria. The unit can be programmed to initiate capture when the current signal is greater than a set value. If no criteria is set, the current input is ignored. The current criteria is then applied to all four current channels simultaneously. When the criteria is satisfied on any one of the four channels, waveform capture will occur.

Status Input Criteria. The unit can be programmed to initiate capture when a status input from channels 0, 1, 2, or 3 changes from a logic zero to logic one or logic one to logic zero. If no criteria is set, the status inputs are ignored. Each status input consumes one combinational criteria.

Number Of Cycles Criteria. The unit can be programmed to initiate capture when a condition persists for a number of consecutive cycles of one to eight. The reason for a maximum of eight is that waveforms are captured for ten cycles prior to and ten cycles after the event causing the initial trigger.

Combinational Logic Criteria. The unit can be programmed to initiate capture when up to six combinations of the above criteria occur. Each criteria is defined by combinations of one to four of voltage criteria, current criteria, status input criteria, and number of cycles criteria.



# SECTION 4 • INSTALLATION

---

## GENERAL

BE1-MMS100 Systems are delivered in sturdy cartons to prevent shipping damage. Upon receipt of the unit, check the Model and Style Number against the requisition and packaging list for agreement. Inspect for damage, and if there is evidence of such, immediately file a claim with the carrier and notify the Basler Electric Regional Sales Office, your Sales Representative or Sales Representative at Basler Electric, Highland, Illinois.

If the unit is not installed immediately, store it in the original shipping package in a moisture and dust free environment.

---

## MOUNTING

Because the unit is of solid-state design, it does not have to be mounted vertically. Any convenient mounting angle may be chosen. BE1-MMS100 Systems are only available in H1 case styles. Overall dimensions and cutout dimension for the H1 case are shown in Figure 4-1. Metric dimensions are shown in parenthesis.

---

## CONNECTIONS

BE1-MMS100 System connections are dependent on the application and scheme used. All inputs or outputs may not be used in a given installation. Incorrect wiring may result in damage to the relay. Be sure to check the model and style number against the options listed in the Style Number identification chart in Section 1 before connecting and energizing a particular unit.

### NOTE

Be sure the BE1-MMS100 System is hard-wired to earth ground with no smaller than 12 AWG copper wire attached to the ground terminal on the rear of the unit case. When the unit is configured in a system with other protective devices, it is recommended to use a separate lead to the ground bus from each relay.

Except as noted above, connections should be made with minimum wire size of 14 AWG. Be sure to use the correct input power for the power supply specified. Figure 4-2 is a typical ac connection diagram. Refer to Section 2, for a rear view of the H1 style case showing the terminal connections.

---

## TESTING

Before a unit is placed in service, it should be tested to verify the compatibility of the scheme and settings with the intended application.

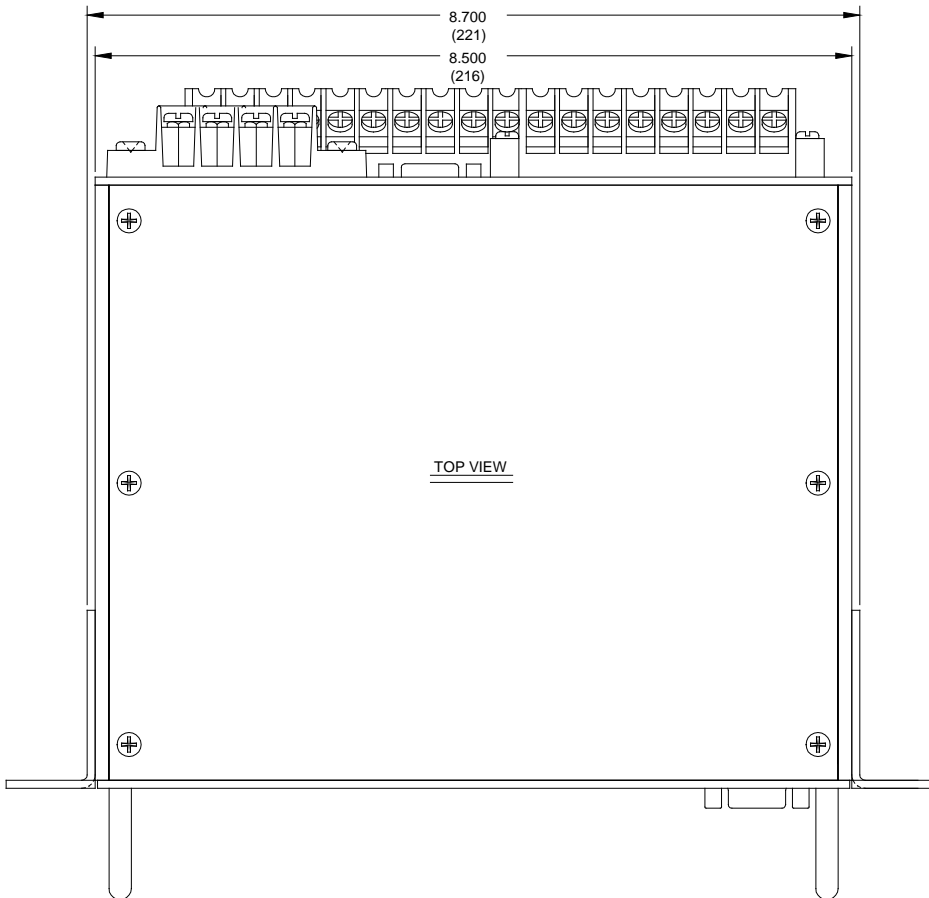
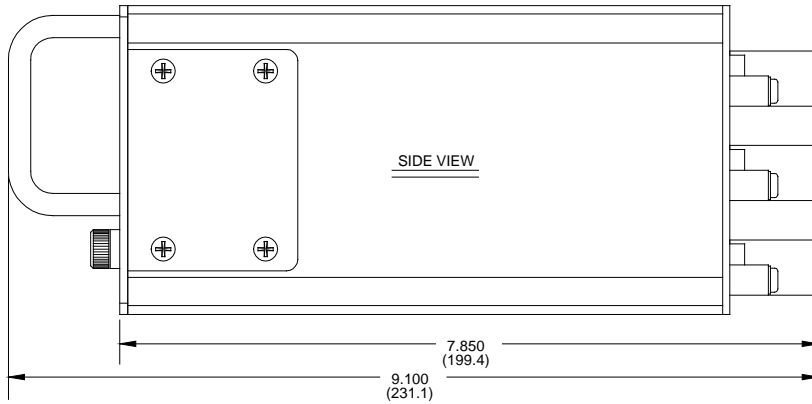
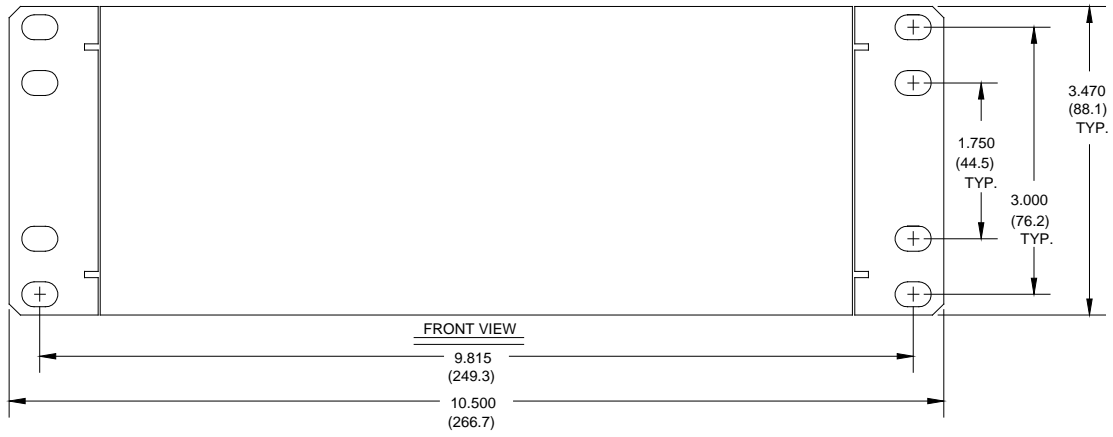

Figure 4-1. BE1-MMS100, H1 Case, Overall Dimensions

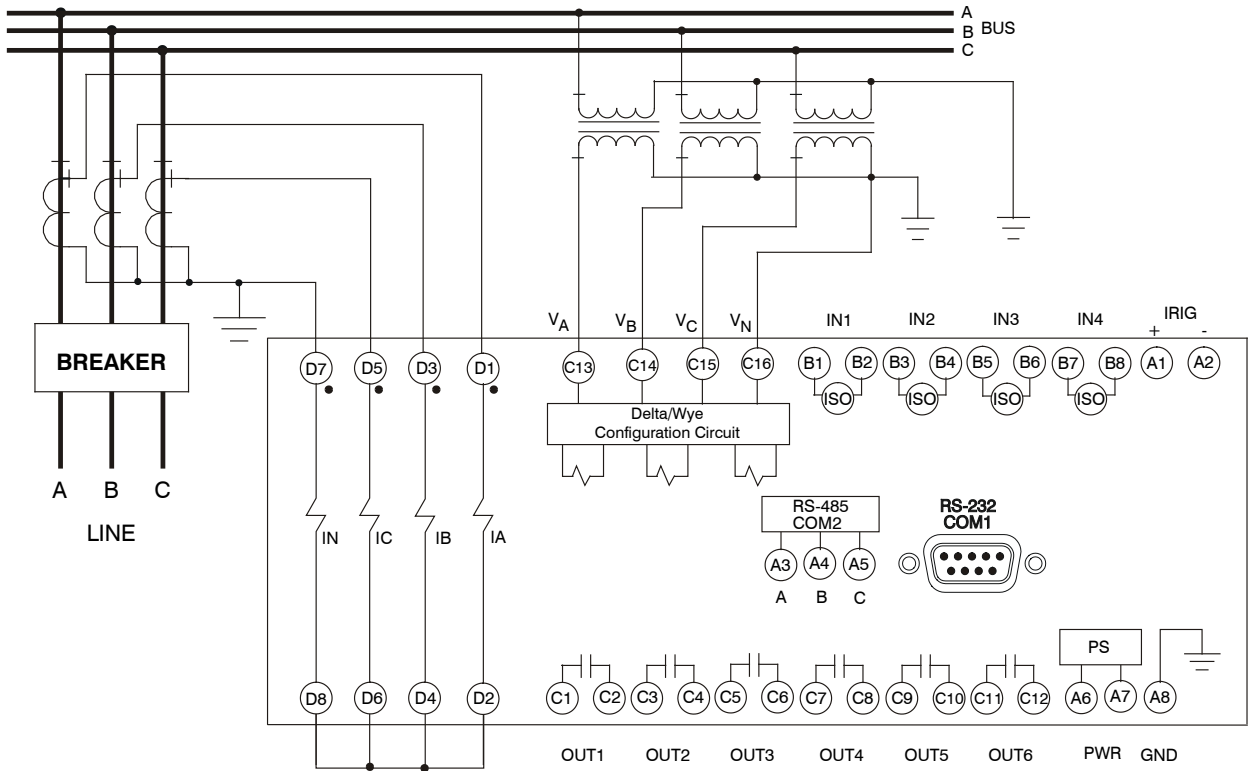

Figure 4-2. Typical AC Connection Diagram

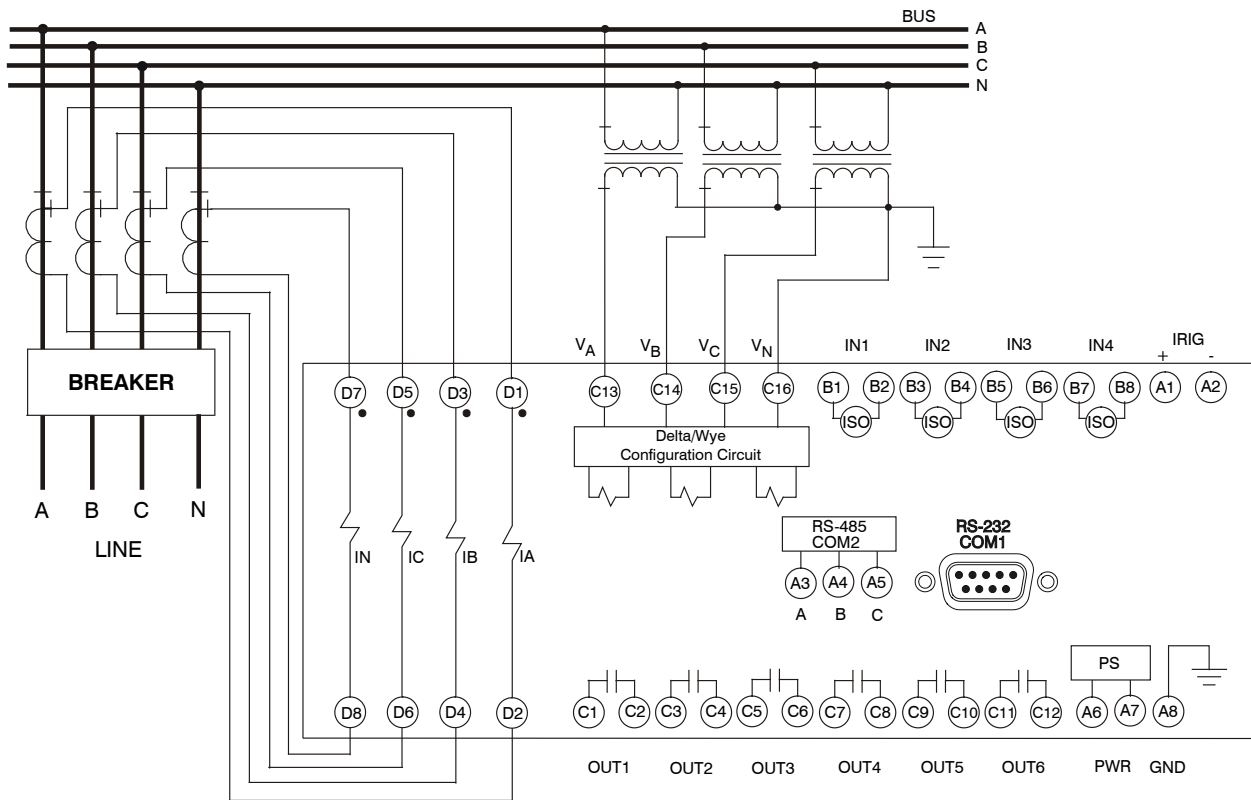

Figure 4-3. Alternate AC Connection Diagram

# COMMUNICATION CONNECTORS AND SETTINGS

## Front/Rear RS-232 Connectors

Front and rear RS-232 connectors are DB-9 female connectors. Connector pin numbers, functions, names, and signal directions are shown in Table 4-1. Figure 4-4 provides an RS-232 cable connection diagram to connect the BE1-MMS100 System to a personal computer.

Table 4-1. RS-232 Pinouts (COM0 And COM1)

Pin	Function	Name	Direction
1	Shield	----	N/A
2	Transmit Data	(TXD)	From Relay
3	Receive Data	(RXD)	Into Relay
4	N/C	----	N/A
5	Signal Ground	(GND)	N/A
6	N/C	----	N/A
7	N/C	----	N/A
8	N/C	----	N/A
9	N/C	----	N/A

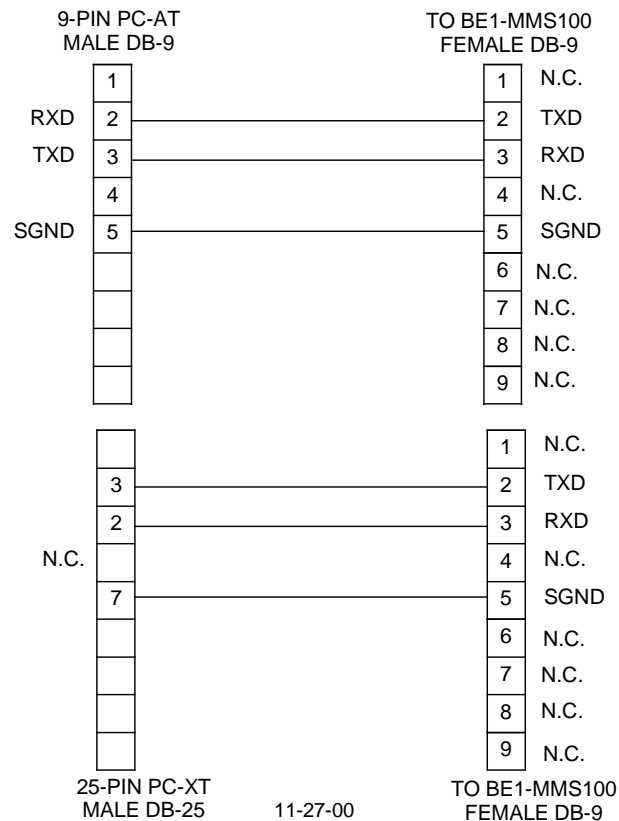

Figure 4-4. Personal Computer To BE1-MMS100

## RS-485 Connector

The RS-485 connector is a three position terminal block connector designed to interface to a standard communication cable. A twisted-pair cable is recommended. Connector pin numbers, functions, names, and signal directions are shown in Table 4-2. A cable connection diagram is provided in Figure 4-5.

Table 4-2. RS-485 Pinouts (COM2)

Terminal	Function	Name	Direction
A	Send/Receive A	(SDA/RDA)	In/Out
B	Send/Receive B	(SDB/RDB)	In/Out
C	Signal Ground	(GND)	N/A

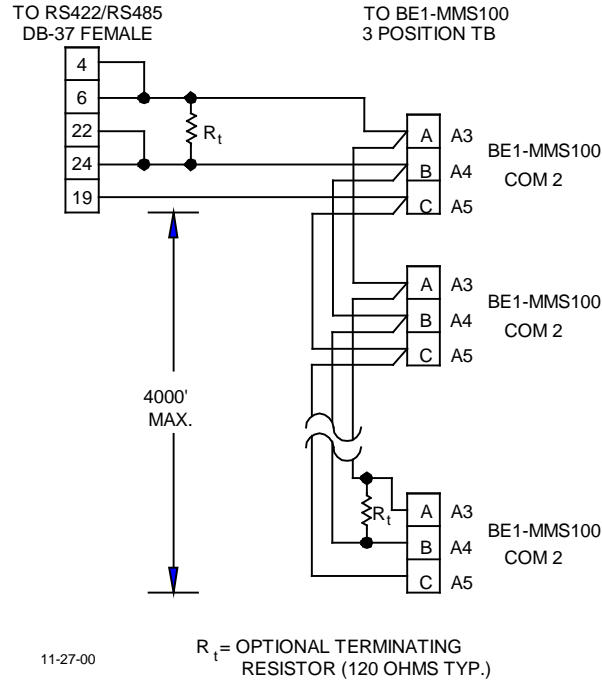

Figure 4-5. RS-485 DB-37 To BE1-MMS100

## MAINTENANCE

BE1-MMS100 Systems require no preventive maintenance. However, testing should be performed according to scheduled practices. If the unit fails to function properly, consult the Customer Service Department of the Power Systems Group, Basler Electric, for a return authorization number prior to shipping.

## STORAGE

This device contains long-life aluminum electrolytic capacitors. For devices that are not in service (spares in storage), the life of these capacitors can be maximized by energizing the device for 30 minutes once per year.

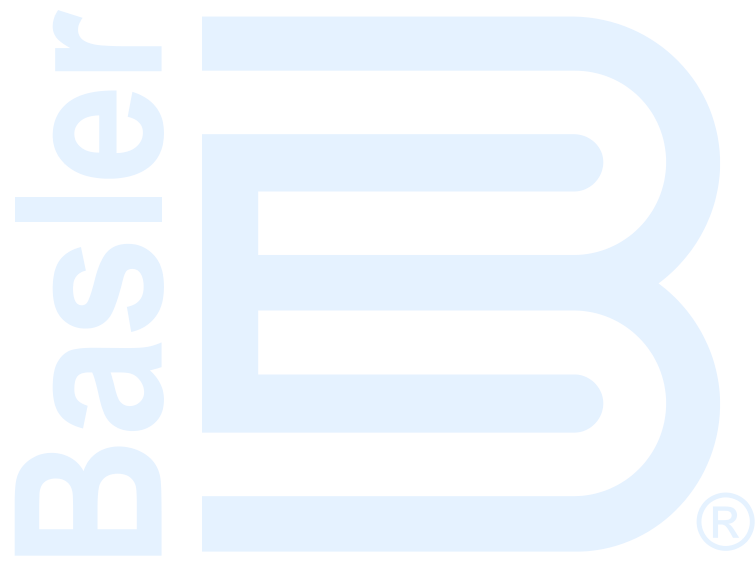

# SECTION 5 • TESTING

---

## GENERAL

BE1-MMS100 Systems require no testing. Built-in self-testing diagnostics indicate that there are no internal problems by flashing the **Unit Status** LED once per second. Refer to Section 2 for the location of the **Unit Status** LED.

To verify that the communications link is working correctly, use the front panel controls to set the unit address to 31. (The h in the unit address 31h designates that the address is hexadecimal and is not variable.) Connect one of the BE1-MMS100 Systems rear communication (LAN) ports to a personal computer with communications and send the following polling command: Ctrl-B1Ctrl-D (Ctrl-B is one keystroke with both keys depressed at the same time, 1 is the second keystroke, and Ctrl-D is the third keystroke). The BE1-MMS100 System should respond with approximately 60 hexadecimal characters.

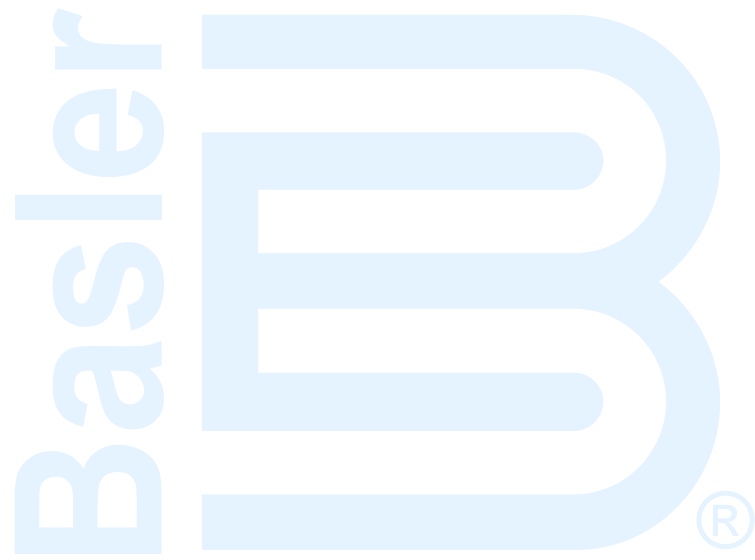





12570 Route 143  
Highland IL 62249-1074 USA  
Tel: +1 618.654.2341  
Fax: +1 618.654.2351  
email: [info@basler.com](mailto:info@basler.com)

No. 59 Heshun Road Loufeng District (N)  
Suzhou Industrial Park  
215122 Suzhou  
P.R. CHINA  
Tel: +86 512.8227.2888  
Fax: +86 512.8227.2887  
email: [chinainfo@basler.com](mailto:chinainfo@basler.com)

111 North Bridge Road  
15-06 Peninsula Plaza  
Singapore 179098  
Tel: +65 68.44.6445  
Fax: +65 68.44.8902  
email: [singaporeinfo@basler.com](mailto:singaporeinfo@basler.com)