

INSTRUCTION MANUAL

FOR

DISTRIBUTION FEEDER PROTECTION RELAY

BE1-DFPR

Unit Revision R And Subsequent

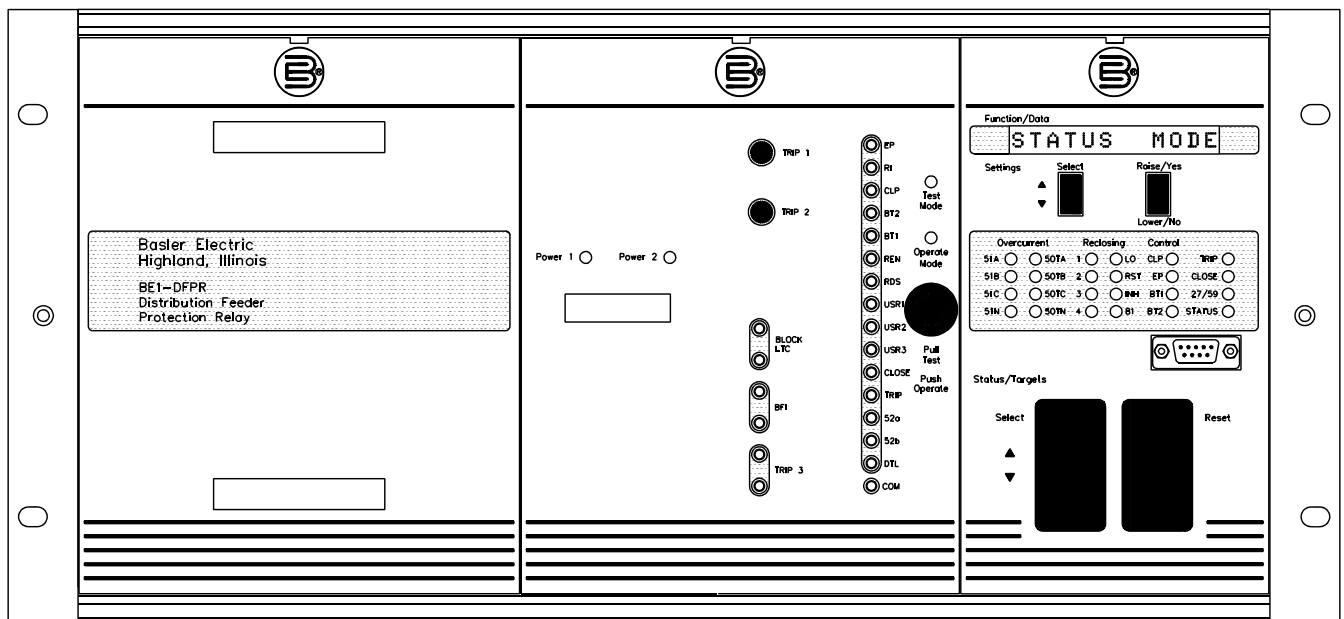

D1355-05
09-03-97



Publication: 9231500985
Revision: B 08/17

INTRODUCTION

This manual provides information concerning the operation and installation of the BE1-DFPR, Distribution Feeder Protection Relay, Unit Revision R and subsequent. BE1-DFPR Relays, Unit Revision Q and previous require Instruction Manual 9231500990. To accomplish these goals, the following information is provided.

- Specifications
- Functional description
- Mounting information
- Setting procedure/example.

WARNING!

To avoid personal injury or equipment damage, only qualified personnel should perform the procedures presented in this manual.



12570 State Route 143
Highland IL 62249-1074 USA

www.basler.com

Info@basler.com

Tel: +1 618.654.2341

Fax: +1 618.654.2351

© 2017 by Basler Electric

All rights reserved

First printing: December 1995

WARNING!

READ THIS MANUAL. Read this manual before installing, operating, or maintaining the BE1-DFPR. Note all warnings, cautions, and notes in this manual as well as on the product. Keep this manual with the product for reference. Only qualified personnel should install, operate, or service this system. Failure to follow warning and cautionary labels may result in personal injury or property damage. Exercise caution at all times.

Basler Electric does not assume any responsibility to compliance or noncompliance with national code, local code, or any other applicable code. This manual serves as reference material that must be well understood prior to installation, operation, or maintenance.

For terms of service relating to this product and software, see the *Commercial Terms of Products and Services* document available at www.basler.com/terms.

This publication contains confidential information of Basler Electric Company, an Illinois corporation. It is loaned for confidential use, subject to return on request, and with the mutual understanding that it will not be used in any manner detrimental to the interests of Basler Electric Company and used strictly for the purpose intended.

It is not the intention of this manual to cover all details and variations in equipment, nor does this manual provide data for every possible contingency regarding installation or operation. The availability and design of all features and options are subject to modification without notice. Over time, improvements and revisions may be made to this publication. Before performing any of the following procedures, contact Basler Electric for the latest revision of this manual.

The English-language version of this manual serves as the only approved manual version.

CONTENTS

SECTION 1	GENERAL INFORMATION	1-1
	Description	1-1
	Functions	1-1
	Protection	1-1
	Control	1-1
	Data Processing	1-1
	Communication	1-1
	Set-up and Test Provisions	1-1
	Features	1-2
	Protection Features	1-2
	Control Features	1-2
	Data Processing Features	1-2
	Communication Features	1-2
	Set-up and Test Provisions Features	1-3
	Application	1-5
	Improving Protection Schemes	1-5
	Implementing Adaptive Schemes	1-5
	Providing Maintenance Information	1-5
	Specifications	1-6
	General Specifications	1-11
	Standard Accessories	1-13
	Model and Style Number Description	1-13
	General	1-13
	Sample Style Number	1-13
	Style Number Identification Chart	1-14
	Time Overcurrent Characteristic Curves	1-15
SECTION 2	CONTROLS AND INDICATORS	2-2
	Location Of Controls And Indicators	2-1
	Control module	2-3
	Contact Sense Module	2-4
	Magnetics Module	2-5
SECTION 3	FUNCTIONAL DESCRIPTION	3-1
	General	3-1
	Block Diagram Analysis	3-1
	General	3-1
	Current Inputs	3-1
	Voltage Inputs	3-1
	Trip Outputs	3-1
	Close Outputs	3-3
	Control Inputs	3-3
	User Programmable Inputs	3-3
	Control Outputs	3-4
	Target Outputs	3-4
	Alarm Outputs	3-5
	Trip Circuit Sense	3-5
	Control Power	3-5
	Communications	3-5

CONTENTS - Continued

SECTION 3 FUNCTIONAL DESCRIPTION (continued)

Modes of Operation	3-6
Settings Mode	3-6
Status Mode	3-8
Auxiliary Settings	3-8
Auxiliary Setting 1 (CLP)	3-8
Auxiliary Setting 2 (EP) 3, And 4	3-9
Overcurrent Protection	3-9
Sensing Configurations	3-9
Time Overcurrent (51, 51N)	3-9
Instantaneous Overcurrent (50, 50N)	3-9
Fixed Time Overcurrent (50T, 50TN)	3-9
Frequency Tripping and Restoration	3-10
Undervoltage Tripping	3-10
Tripping Logic	3-10
Automatic Reclosing	3-11
Zone Sequence Coordination	3-12
Contact Sensing Inputs	3-12
Reclose Initiate (RI)	3-12
Reclose Disable (RDS)	3-13
Reclose Enable (REN)	3-13
Drive To Lockout (DTL)	3-13
Reclose Logic	3-13
Control Functions	3-13
Supervisory Trip/Supervisory Close (Trip/Close)	3-13
Block Load Tap Changer (BLTC)	3-13
System Diagnostics and Alarm Outputs	3-14
Relay Trouble	3-14
Target Repeat Contacts	3-14
Breaker Fail Alarm	3-14
Lockout Alarm	3-14
Programmable Alarms	3-14
Instrumentation	3-15
Real Time Values	3-15
Demand Values	3-15
Status Conditions	3-15
Data Collection and Storage	3-15
Fault Data	3-15
Communications	3-16
General	3-16
RS 232-C Format	3-17
Serial Port Connections and Configurations	3-17
Serial Communication	3-19
Starting Communication	3-19
Downloading And Uploading Settings	3-19
Capturing Data To A File	3-22

SECTION 4 INSTALLATION

4-1

General	4-1
Operating Precautions	4-1

CONTENTS - Continued

SECTION 4	INSTALLATION (continued)	
	Dielectric Test	4-1
	Mounting	4-1
	Outline Dimensions (Rack Mounting)	4-2
	Outline Dimensions (Panel Mounting)	4-3
	Connections	4-4
	DC Control Connections (Typical)	4-4
	Connection Diagram	4-5
	BE1-DFPR Rear View	4-6
	Communications Interface	4-7
	RS-232 Connection Diagram For IBM Type Computers	4-8
	RS-232 Interconnection Diagram For PRT	4-9
	RS-232 Interconnection Diagram For RFL 9660 Switch	4-9
SECTION 5	TESTING	5-1
	General	5-1
	Testing	5-1
	Operational Test Procedure	5-1
	Preliminary Setup Procedure	5-1
	Entering Time and Date Settings	5-1
	BE1-DFPR Test Simulator, Front View	5-2
	BE1-DFPR Test Simulator, Rear View	5-3
	BE1-DFPR Test Simulator, Schematic Diagram	5-4
	Test Setup Diagram	5-6
	Entering Settings	5-7
	Pickup Verification	5-7
	Timing Verification	5-11
	Breaker Duty Timers	5-14
	Control Inputs	5-15
	Outputs	5-17
	Self Test	5-19
	Trip Test	5-21
	Loading Factory Default Settings	5-22
	Normal, AUX1, AUX2, AUX3, And AUX4 Settings	5-22
	Installation Settings	5-22
	Other Parameters	5-23
	Load Default Settings	5-23
	Resetting Demand Values	5-24
SECTION 6	MAINTENANCE	6-1
	General	6-1
	In-House Repair	6-1
	Storage	6-1
SECTION 7	MANUAL CHANGE INFORMATION	7-1

SECTION 1

GENERAL INFORMATION

DESCRIPTION

BE1-DFPR Distribution Feeder Protection Relays are microprocessor controlled devices with communications that provide complete real time protection, monitoring, control, and instrumentation for distribution circuits. In summary, it is an integrated feeder supervision system. DFPR relay communication provides for collection of real time operational data on both protected distribution circuits and controlled circuit breakers. Communication also provides fault data and distribution circuit status to a local or remote location, and allows the user to change the settings or select relay predefined conditional settings to meet existing operating system conditions as they occur.

FUNCTIONS

DFPR relay multiple functions provide protection, control, data processing, communication, set-up provisions, and test provisions. These functions are expanded and listed in the following paragraphs.

Protection

- Three-phase and neutral overcurrent.
- Breaker failure.
- Undervoltage and Overvoltage for each phase.
- Frequency tripping/restoration.

Control

- Multiple shot reclosing (4-shot).
- Reclosing may be controlled with external inputs.
- Accepts breaker, trip and close inputs.
- Protection may be adapted to system conditions.

Data Processing

- Measures watts, var, voltamperes, power factor, frequency, volts, or amperes.
- Calculates present and stores minimum and maximum demand values.
- Measures energy accumulation in watt hours and var hours.
- Accumulates data on breaker duty.
- Stores fault/event reports.
- Output contacts provide status information for SCADA.

Communications

- Menu driven operation.
- Front and rear panel RS-232 ports.
- Uses terminal or PC with off-the-shelf software.
- Optional RS-485 rear port supporting special application protocols.

Set-up and Test Provisions

- Standard connection/test plugs for testing in the case.
- Test module for control inputs (option).
- Test unit is available to simplify testing.
- Built-in self-checking capabilities.
- Built-in breaker trip circuit monitor.

FEATURES

Each DFPR relay function has many different features. These features are also listed in the following paragraphs and elaborate on the expanded functions.

BE1-DFPR General Information

Protection Features

- Programmable integrating reset characteristics available for 51 functions.
- Current and voltage sensing elements attenuate offsets and harmonics.
- Different time overcurrent curves may be selected for phase and neutral.
- Instantaneous overcurrent elements are provided for phase and neutral.
- Fixed time overcurrent elements are provided for phase and neutral.
- Tripping elements and the response of the reclosing section may be set for normal, AUX 1 (cold load), AUX 2 (emergency), AUX 3 and AUX 4 settings by control inputs.
- In addition to the main tripping outputs, an independent trip output may be programmed to operate on any of the protective functions.
- Control inputs are provided to block all fixed time overcurrent elements and/or the neutral fixed time and neutral time overcurrent elements.
- The breaker failure element may be initiated by any protective tripping function or a supervisory trip.
- A breaker fail alarm contact is provided to indicate breaker problems that occur before the breaker fail function is actually caused to operate.
- Zone sequence coordination provided.

Control Features

- The reclosing function includes two programmable close outputs, inputs for initiate, drive-to-lockout, and enabling or disabling reclosing.
- The reclosing section of the relay is deactivated to prevent pumping when the breaker is tripped or closed through one of the control inputs.
- An output is provided to block the load tap changer on the substation transformer or voltage regulator during a fault clearing or restoration process.
- Overcurrent protective functions may be adapted through BT1 and BT2 control inputs.
- Programmable inputs available for control features.

Data Processing Features

- Data is formatted to display information in logical groups on computer or terminal.
- Demand values are calculated for phase currents, watts, var, and voltamperes for intervals from one to sixty minutes.
- Energy accumulation in watt hours, var hours, and the number of hours since last reset are calculated and stored.
- Data stored on breaker duty includes number of operations and the sum of the I^2 or I values interrupted.
- Fault/event data is stored for up to 40 breaker operations.
- Parameters being measured and/or stored may be displayed on the front panel.
- Status outputs are provided for targets and reclose functions.
- Battery backed-up clock provides date and time for reports.
- Programmable alarm outputs available for alarm functions.

Communications Features

- Front RS-232 port for observing menus and groups of data or set-up parameters via a portable computer terminal.
- Rear RS-232 port for connection to a communications link.
- Communications provides access to set-up parameters, real time data, and stored information.
- Settings upload and download.

Set-up and Test Provision Features

- Access to the connection/test plugs is achieved by removing the left section of the front panel.
- The optional test module provides the means to disconnect control inputs and apply test signals through the test points.
- Front panel display for reading data and setting parameters.
- Menu driven procedures are user friendly.

Figure 1-1 illustrates the path through the menu structure and the required keystrokes to enter and exit each screen. A MAIN MENU provides selections for the main activities. REVIEW/EDIT SETTINGS MENU allows the user to select a complete group of settings. When the activity of the selected screen is complete, the user is returned to the menu for another activity selection.

BE1-DFPR General Information

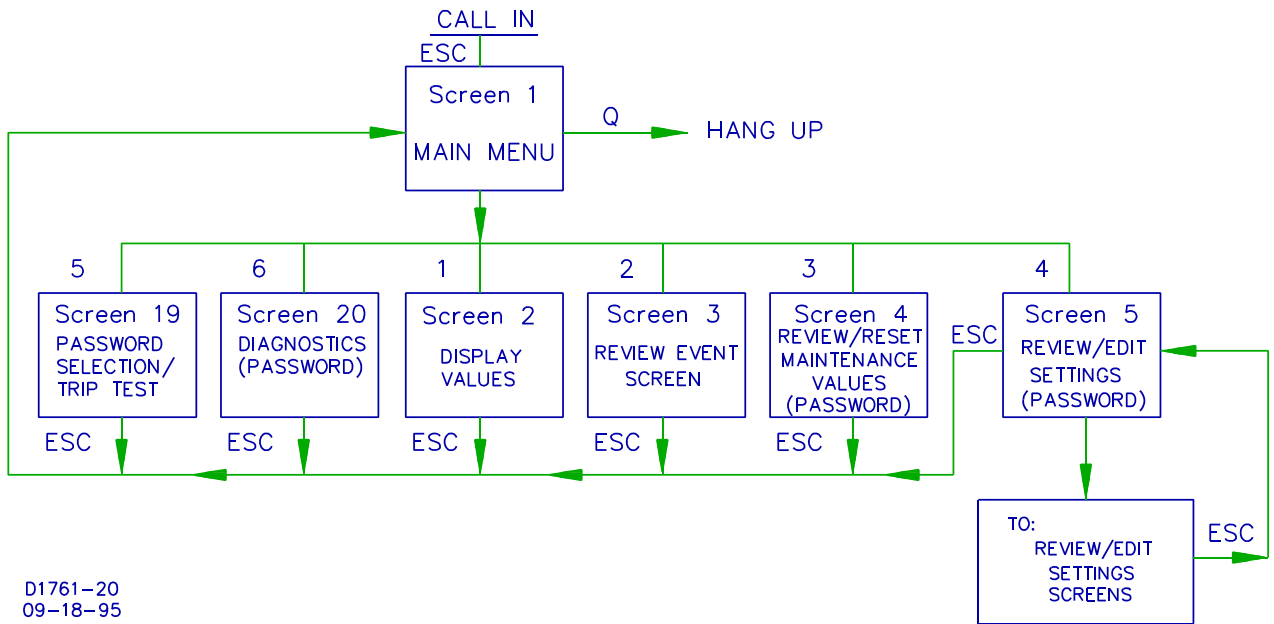

Figure 1-1. Terminal Screens Flow Diagram (Sheet 1 Of 2)

BE1-DFPR General Information

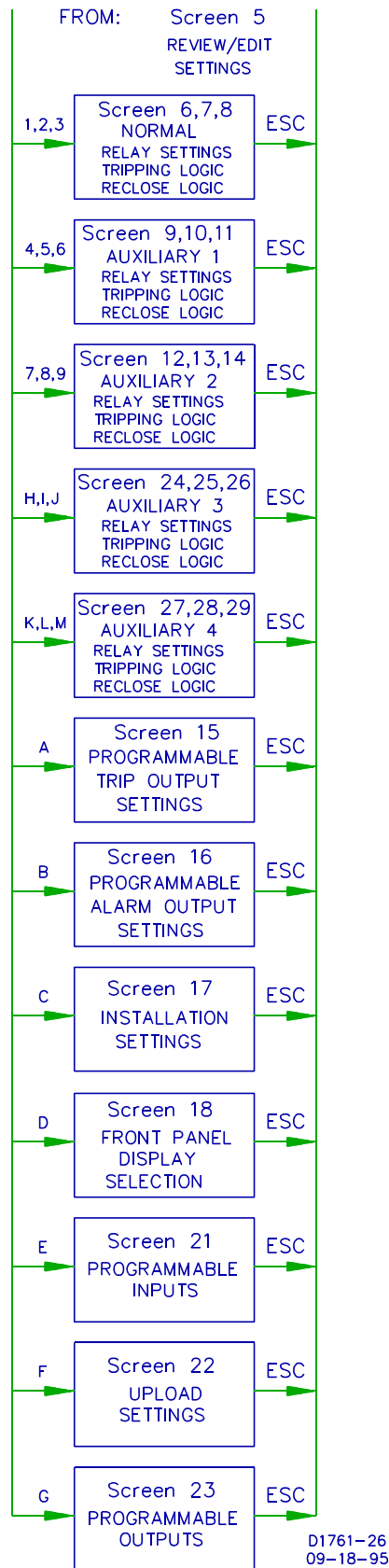

Figure 1-2. Terminal Screens Flow Diagram (Sheet 2 Of 2)

BE1-DFPR General Information

APPLICATION

Distribution feeders represent the majority of circuits in a utility system. These circuits are typically radial, three-phase, and operate over the range of 2.4 to 35 kV. In the majority of distribution substations, circuit breakers are used to interrupt these circuits, with fuses and sectionalizers providing fault isolation downstream. Because the substations are usually in remote areas, it is desirable to be able to control the breaker from a central dispatch office. Total automation of these distribution systems, including real time load and demand data collection for each feeder, is also desirable. BE1-DFPR Distribution Feeder Protection Relays provide both protection and data collection.

Improving Protection Schemes

Quantity of data and status information that can be collected is limited by the space available to mount discrete devices and the capability of SCADA terminals to collect and process data. BE1-DFPR relays are multi-phase, multi-function devices in economical, standard 19-inch rack units and require less space than the equivalent electromechanical overcurrent relays.

Overcurrent elements in DFPR relays are tuned to the fundamental frequency (50 or 60 hertz) and, thereby, rejects offsets and harmonics. This provides the means to achieve more sensitive neutral overcurrent protection in feeders with high harmonic content. In addition to overcurrent protection, DFPR relays include undervoltage elements that may be used for undervoltage load-shedding applications.

DFPR relays also include a complete multiple shot reclosing unit with four shot capabilities. By integrating this function along with the protective functions, it is possible to program the reclosing system to respond in a specified manner to operations of the various tripping elements. This makes it possible to implement improved logic in the reclosing scheme.

DFPR relays have the means to selectively trip individual feeders on underfrequency conditions and to automatically restore them at selected frequencies.

Breaker fail outputs (BFO) may be used to activate breaker failure schemes. This involves tripping a breaker or breakers upstream from the one that failed.

Implementing Adaptive Schemes

One adaptive capability of DFPR relays is to revert to normal, auxiliary one (cold load pickup), auxiliary two (emergency), auxiliary three, or auxiliary four setting groups in accordance with the control inputs applied to the relay. DFPR relays can, if desired, automatically revert to auxiliary one (cold load pickup) settings if the feeder has been dead for a preset time. Normal settings are restored if automatic entrance to the auxiliary one settings has occurred and the feeder has been energized for ten minutes.

DFPR relays include a control input for blocking all fixed time overcurrent elements. It also includes a control input for blocking neutral fixed time and neutral time overcurrent elements. Control inputs are also provided for enabling or disabling the reclose function.

Providing Maintenance Information

DFPR target and reclose function status output contacts may be interfaced with a SCADA system to give the operator additional information about what occurred on a feeder that tripped. This information is used to help guide maintenance personnel.

Through communications, DFPR relays provide information about the type of fault. This information is obtained from the fault report under REVIEW EVENT SCREEN. The report lists fault currents, voltages, targets, breaker operate time, reclose status, and general information. By interpreting the fault information, the fault location can be estimated.

Information is also provided by the DFPR to schedule breaker maintenance. Available is the number of breaker operations and arc cumulated contact wear. This information is accessible through communications under REVIEW/RESET MAINTENANCE VALUES SCREEN.

DFPR relays store minimum and maximum demand values. This information can be retrieved periodically to keep track of load peaks and growth for planning purposes.

SPECIFICATIONS

BE1-DFPR relays are available with the following features and capabilities.

BE1-DFPR General Information

Accuracies of Measured Currents

Refer to Table 1-1 for accuracies of front panel instrumentation measured currents.

Table 1-1. Accuracies of Instrumentation Currents

For 5 A CT	For 1 A CT	Accuracy
0.1 to 0.5 A	0.02 to 0.1 A	$\pm 5\%$ or ± 15 mA
0.5 to 2.0 A	0.1 to 0.4 A	$\pm 3\%$
2.0 to 7.5 A	0.4 to 1.5 A	$\pm 2\%$

Accuracies of Measured Voltages

Refer to Table 1-2 for accuracies of front panel instrumentation measured voltages.

Table 1-2. Accuracies of Instrumentation Voltages

Voltage	Accuracy
40 to 130	$\pm 2\%$

Calculated Values and Accuracy

Present values:
Demand values:
Accuracy:
Demand intervals:

W, var, VA, pf
A, W, var, VA
Better than $\pm 4\%$ for all values
1 to 60 min.

Date And Time Clock

Accuracy: 3 seconds per day at 25°C
Resolution:
Backup battery:
Battery life:
Date and time setting provisions:

10 milliseconds
Lithium carbon monofluoride
20 years
Front panel and communications port

Recognition Time On Contact Inputs

8 ms.

AC Response Characteristics

50 Hz range:
60 Hz range:

Rejects harmonics higher than second by 12 db or more.
Rejects dc offsets
40 to 55 Hz
50 to 65 Hz

BE1-DFPR General Information

**Current Pickup For Phase and Neutral
Time Elements (51, 51N)**
5 Ampere CT

Dropout/pickup ratio: 95% or higher

Range 0.5 to 12 A
Increments 0.1 A
Pickup accuracy ±2% or 50 mA

1 Ampere CT

Range 0.1 to 2.4 A
Increments 0.02 A

**Time Characteristic Curves
(FOR 51, 51N ELEMENTS)**

Refer to Table 1-3. Timing accuracy within 5% or 40 milli-seconds, whichever is greater for time dial settings greater than 0.1 and multiples of 2 to 40 times pickup setting.

Eleven inverse time functions and one fixed time function can be selected. Characteristic curves for the inverse and definite time functions are defined by the trip and integrating reset characteristic equations and shown graphically in Figures 1-5 through 1-16.

Table 1-3. 51, 51N Characteristic Curves

Type	Curve Name	Figure Number
S	Short Inverse	Figure 1-5
L	Long Inverse	Figure 1-6
D	Definite Time or IDMT	Figure 1-7
M	Moderately Inverse	Figure 1-8
I	Inverse Time	Figure 1-9
V	Very Inverse	Figure 1-10
E	Extremely Inverse	Figure 1-11
A	BS142 Standard Inverse	Figure 1-12
B	BS142 Very Inverse (It)	Figure 1-13
C	BS142 Extremely Inverse (I ² t)	Figure 1-14
G	BS142-Longtime Inverse	Figure 1-15
F	Fixed Time	Figure 1-16

Trip Characteristic

Characteristic curves for the inverse and definite time functions are defined by the following equation.

Where:

- D = TIME DIAL setting
- M = Multiple of PICKUP setting
- A, B, C, N, K = Constants for the particular curve

BE1-DFPR General Information

Trip Characteristic

Refer to Table 1-4 for the time characteristic curve constants. Constants have been selected to conform to the characteristics of electromechanical relays over a range of pickup multiples from 1.3 to 40. Values of the constants are available for use in computer relay setting programs.

The fixed time characteristic (curve type F) provides delays of 0.0 to 9.9 seconds corresponding to the time dial setting. The time set is constant over a range of pickup multiples from 1.0 to 40.

Integrating Reset Characteristic

Front panel selectable for 51P, 51N, or 51P and 51N using the 51 RESET setting. The integrating reset characteristic curves are defined by the following equation.

Where:

- D = TIME DIAL setting
- M = Multiple of PICKUP setting
- A_r = Constant for the particular curve (Table 1-4)

Table 1-4. 51 And 51N Time Characteristic Curve Constants

Curve Type	Characteristic Constants					
	Trip					Reset
	A	B	C	N	K	A_r
S	0.2663	0.03393	1.000	1.2969	0.028	0.500
L	5.6143	2.18592	1.000	1.000	0.028	15.75
D	0.4797	0.21359	1.000	1.5625	0.028	0.875
M	0.3022	0.12840	1.000	0.5000	0.028	1.750
I	8.9341	0.17966	1.000	2.0938	0.028	09.00
V	5.4678	0.10814	1.000	2.0469	0.028	05.50
E	7.7624	0.02758	1.000	2.0938	0.028	07.75
A	0.01414	0.00000	1.000	0.0200	0.028	02.00
B	1.4636	0.00000	1.000	1.0469	0.028	03.25
C	8.2506	0.00000	1.000	2.0469	0.028	08.00
G	12.1212	0.00000	1.000	1.000	0.028	29.00
F	0.0000	1.00000	0.000	0.0000	0.000	0.000

Curve Type:

- | | | |
|-----------------------------|-----------------------------|------------------------|
| S = Short Inverse | L = Long Inverse | D = Definite Time |
| M = Moderately Inverse | I = Inverse | V = Very Inverse |
| E = Extremely Inverse | A = BS142 Standard Inverse | B = BS142 Very Inverse |
| C = BS142 Extremely Inverse | G = BS142 Long Time Inverse | F = Fixed Time |

Curves A, B, C, and G are defined in British Standard BS142.

Fixed Time Parameters (For 50T, 50TN Elements)

Characteristic:	Fixed time for any current exceeding pickup
Time Range:	30 to 5000 ms
Time Increments:	10 ms
Reset:	Reset is instantaneous
Timing accuracy:	±5% or 15 ms, whichever is greater

Current Pickup For Phase And Neutral Fixed Time Elements (50T, 50TN)

Dropout/Pickup ratio: 90%.
Pickup accuracy: ±5%

BE1-DFPR General Information

5 Ampere CT

Range 0.5 to 150 A
 Increments 0.1 A

1 Ampere CT

Range 0.1 to 30 A
 Increments 0.02 A

**Instantaneous Response Characteristics
 (For 50, 50N Elements)**

Characteristic:

Refer to Figure 1-3 for the instantaneous response range.

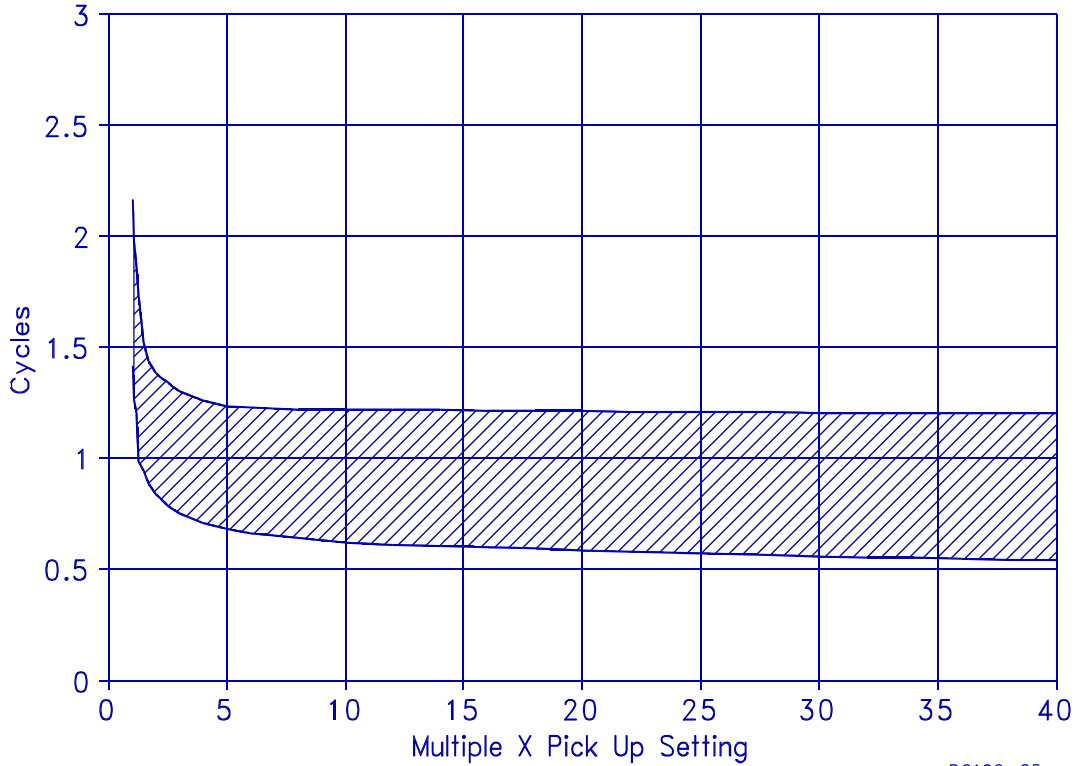

D2106-25
 11-28-95

Figure 1-3. Instantaneous Response Characteristics (50, 50N Elements)

**Current Pickup For Phase And Neutral
 Instantaneous Elements (50, 50N)
 5 Ampere CT**

Dropout/Pickup ratio: 90%.
 Pickup accuracy: $\pm 5\%$

Range 0.5 to 150 A
 Increment 1.0 A

**Current Pickup (50, 50N) - Continued
 1 Ampere CT**

Range 0.1 to 30 A
 Increment 0.2 A

**Overvoltage Response characteristic
 (For 59 Element)**

NOTE
 A time dial (time range) setting of 0.0 inhibits the 59 function.

Characteristic:	Fixed time
Time range:	0.0 to 100 seconds
Setting increments:	0.1 second
Reset	16 ms or less
Timing accuracy:	$\pm 5\%$ for settings greater than 5 seconds

BE1-DFPR General Information

CAUTION

The 59 pickup element must not be set lower than the 27 pickup element. Doing so will cause a trip condition.

Overvoltage Pickup Setting (For 59 Element)

Setting range:	50 to 150 volts
Setting increments:	1.0 volt
Pickup accuracy:	±2%
Dropout/Pickup ratio:	90%

Acceptable Setting Example: If 27 = 100, then 59 must be \gt 100

NOTE

A time dial (time range) setting of 0.0 inhibits the 27 function.

Undervoltage Response Characteristic (For 27 Element)

Characteristic:	Fixed time
Time range:	1 to 1000 seconds
Setting increments:	1 seconds
Reset:	16 ms or less
Timing accuracy:	±5% for settings greater than 5 seconds.

CAUTION

The 27 pickup element must not be set higher than the 59 pickup element. Doing so will cause a trip condition.

Undervoltage Pickup Setting (For 27 Element)

Setting range:	50 to 100% of nominal input
Setting increment:	1 V
Pickup accuracy:	±2%
Dropout/Pickup ratio:	110% or higher

Acceptable Setting Example: If 59 = 120, then 27 must be \lt 120

Underfrequency Response Characteristics (For 81 Element)

Characteristic:	Fixed time
Time range:	100 to 500 ms
Setting increments:	10 ms
Reset:	Two cycles or less
Timing accuracy:	10% or 50 ms, whichever is greater

Underfrequency Pickup Setting (81)

Voltage supervision range:	40 to 120 V
Setting range:	Nominal frequency +5 Hz, -10 Hz
Setting increment:	0.01 Hz
Pickup accuracy:	0.01 Hz

Restoration-Frequency Response Characteristic (For 81 Element)

Conditional requirement:	Underfrequency trip has occurred
Characteristic:	Definite time
Time range:	1 to 1000 seconds
Time increment:	1 seconds
Timing accuracy:	±5% or 200 ms, whichever is greater

BE1-DFPR General Information

Restoration-Frequency Pickup Setting (81)

Voltage supervision range:	40 to 120 V
Setting range:	Nominal frequency +5 Hz, -10 Hz
Setting increment:	0.01 Hz
Pickup accuracy:	0.01 Hz

Reclosing Relay Timers (For 79 Element)

Reclosing delays (4):	0.00 to 100 seconds (0 = inhibit)
Reset time range:	1 to 200 seconds
Maximum cycle time:	0 to 999 seconds (0 = inhibit)
Fail to reclose timer:	0.0 to 9.9 seconds (0 = inhibit)
Timing Accuracy	5% or 30 ms whichever is greater

Breaker Fail Timer (For 50BF Element)

Delay range:	30 to 500 ms
Setting increment:	10 ms
Reset time:	16 ms or less
Timing Accuracy	5% or 8 ms whichever is greater

GENERAL SPECIFICATIONS

AC Voltage Inputs At 50 Hz

Nominal:	100, 173 or 192 V phase-to-phase
Continuous:	133 V phase-to-neutral
One second rating:	260 V
Burden:	Less than 1.0 VA at 100 V phase-to-neutral

AC Voltage Inputs At 60 Hz

Nominal:	120, 208 or 230 V phase-to-phase
Continuous:	160 V phase-to-neutral
One second rating:	320 V
Burden:	Less than 1.0 VA at 120 V phase-to-neutral

AC Current Inputs On Unit For 5 A CTs

Continuous:	20 A
One second rating:	500 A
Saturation limit:	250 A
Burden:	Less than 1.0 ohm

AC Current Inputs On Unit For 1 A CTs

Continuous:	4 A
One second rating:	100 A
Saturation limit:	50 A
Burden:	Less than 1.0 ohm

Control Power

48 V, 0.30 A, range 35-57 Vdc
125 Vdc, 0.12 A, range 90-150 Vdc
120 Vac, 0.16 A, range 90-132 Vac

Trip Contacts

Make and carry for tripping duty:	30 A for 0.2 seconds per ANSI C37.90
Continuous:	3 A
Break resistive or inductive:	0.3 A at 250 Vdc (L/R = 0.04 maximum)

BE1-DFPR General Information

Auxiliary And Alarm Contacts

Make and carry: 3 A
Break resistive or inductive; 0.3 A at 250 Vdc (L/R = 0.04 maximum)

Target Indicators

Magnetically latched, manually reset target indicators are current operated for TRIP 1 and TRIP 2 outputs. Target indicators are operated by a minimum of 0.2 A through the output trip circuit. Output circuit is limited to 30 A for 0.2 seconds, 7 A for 2 minutes, and 3 A continuously.

Control Inputs

Voltage range: Same as control power
Nominal current: 15 ma

Communication Ports

RS-232-C on front panel for connection to a portable terminal. RS-232-C on rear panel for connection to a modem

Dielectric Strength (Isolation)

1500 Vac at 50/60 Hz in accordance with IEEE C37.90 and IEC 255-5. Excludes RS-232-C ports.

Surge Withstand Capability

Qualified to ANSI/IEEE C37.90.1-1989 Standard Surge Withstand Capability (SWC) Tests for Protective Relays and Relay Systems.

Fast Transient

Qualified to ANSI/IEEE C37.90.1-1989 .

Radio Frequency Interference (RFI)

Type tested using a five watt, hand-held transceiver in the ranges of 144 and 440 MHz with the antenna placed within six inches of the relay.

Environment

Operating temperature range: -40°C to 70°C (-40°F to 158°F)
Storage temperature range: -40°C to 70°C (-40°F to 158°F)
Humidity: 95% non-condensing

Shock

In standard tests, the relay has withstood 15 g in each of three mutually perpendicular planes without structural damage or degradation of performance.

Vibration

In standard tests, the relay has withstood 2 g in each of three mutually perpendicular planes, swept over the range of 10 to 500 Hz for a total of six sweeps, 15 minutes each sweep, without structural damage or degradation of performance.

Weight

Maximum weight 35 pounds

Case Size

19 inch rack mount
8.75 inches high (5 rack units)
8.2 inches deep (behind mounting surface)
Available for horizontal or vertical mounting

STANDARD ACCESSORIES

A test set is available for providing input power and signals for a full functional test. The test set includes switches to manually activate sensing inputs and indications for trip and close outputs. User must fabricate

BE1-DFPR General Information

a harness to make connection between the test box and the relay. Make connections to the relay using connection plugs, Basler Electric part number 09115, for current and voltage inputs, and trip and close outputs. Standard 0.080 diameter phone tip-plugs are used to connect contact sensing inputs to the test points when in test mode or when monitoring the inputs in operate mode.

To order the test set, specify part number 9-2315-42-100.

MODEL AND STYLE NUMBER DESCRIPTION

General

BE1-DFPR Relays electrical characteristics and operational features are defined by a combination of letters and numbers that make up its style number. The model number, together with the style number, describe the options included in a specific device, and appear on the metal shelf behind the magnetics panel, and on the outside rear case assembly. Upon receipt of a relay, be sure to check the style number against the requisition and the packing list to ensure that they agree.

Sample Style Number

Style number identification chart (Figure 1-4) defines the electrical characteristics and operational features included in BE1-DFPR Relays. For example, if the style number were **5 A2 V F T H A**, the device would have the following:

- (5)** - Five ampere system current transformer secondaries.
- (A2)** - Two power supplies, operating voltage 125 Vdc or 120 Vac.
- (V)** - Undervoltage protection.
- (F)** - Underfrequency protection.
- (T)** - Control input test module.
- (H)** - Horizontal mount.
- (A)** - RS-232-C terminal communications

BE1-DFPR General Information

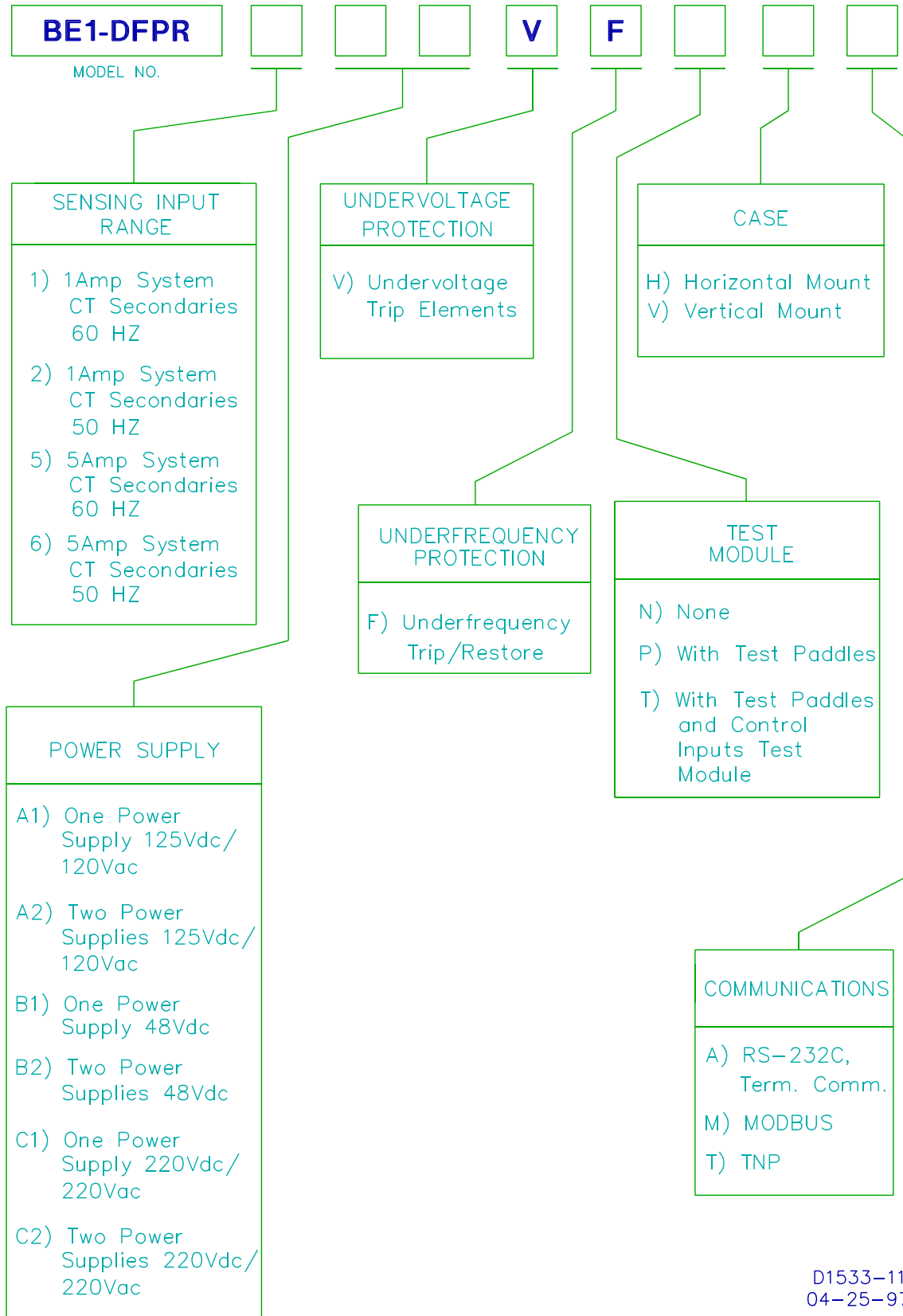

D1533-11
04-25-97

Figure 1-4. Style Number Identification Chart

BE1-DFPR General Information

TIME OVERCURRENT CHARACTERISTIC CURVES

Figures 1-5 through 1-16 illustrate the characteristic curves that are programmed into the nonvolatile memory of this relay. A drawing number is given under each caption. Use this number to order a full-size (10 inch x 12 inch) Characteristic Curve graph.

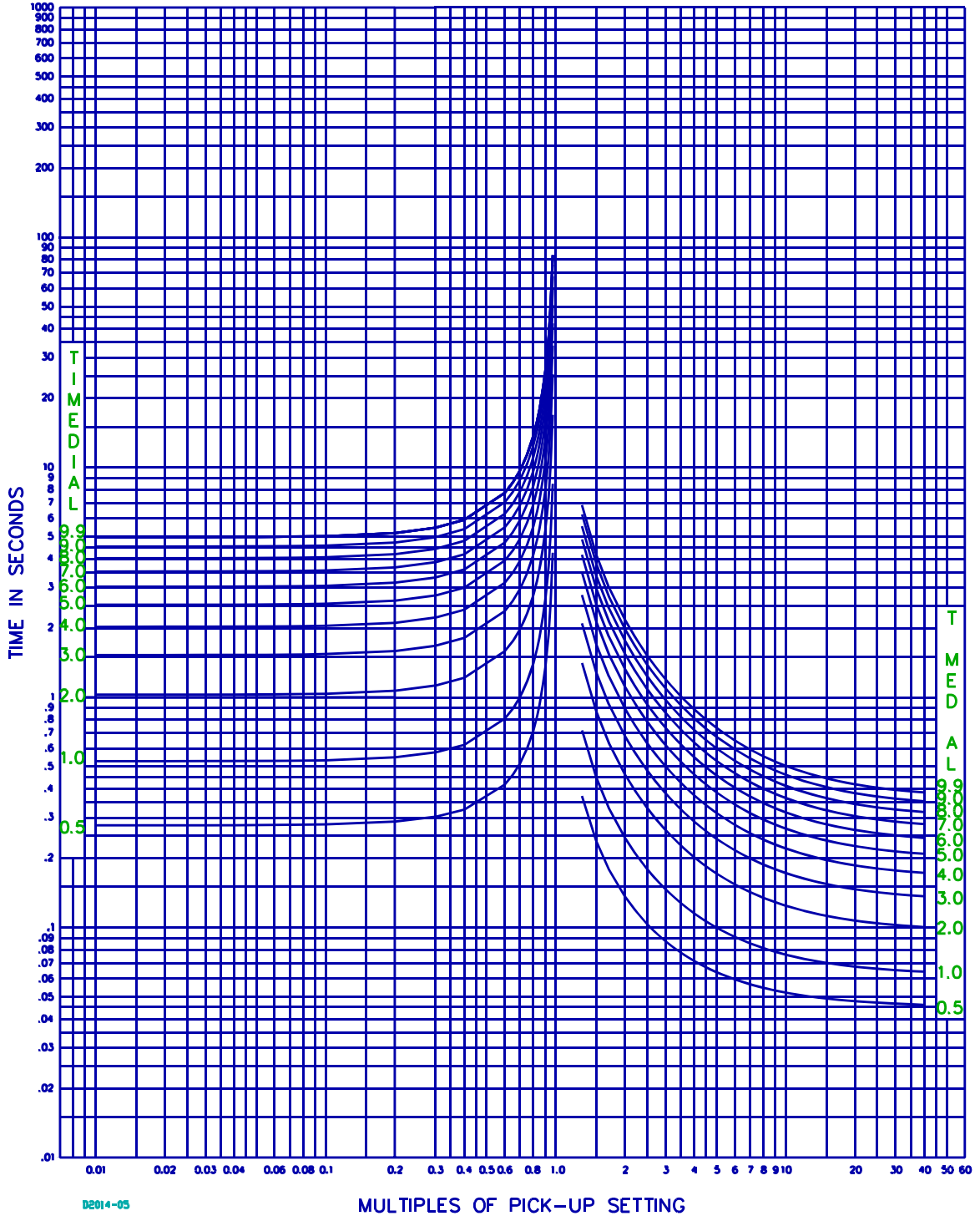

Figure 1-5. Timing Option S, Short Inverse (99-1557)

BE1-DFPR General Information

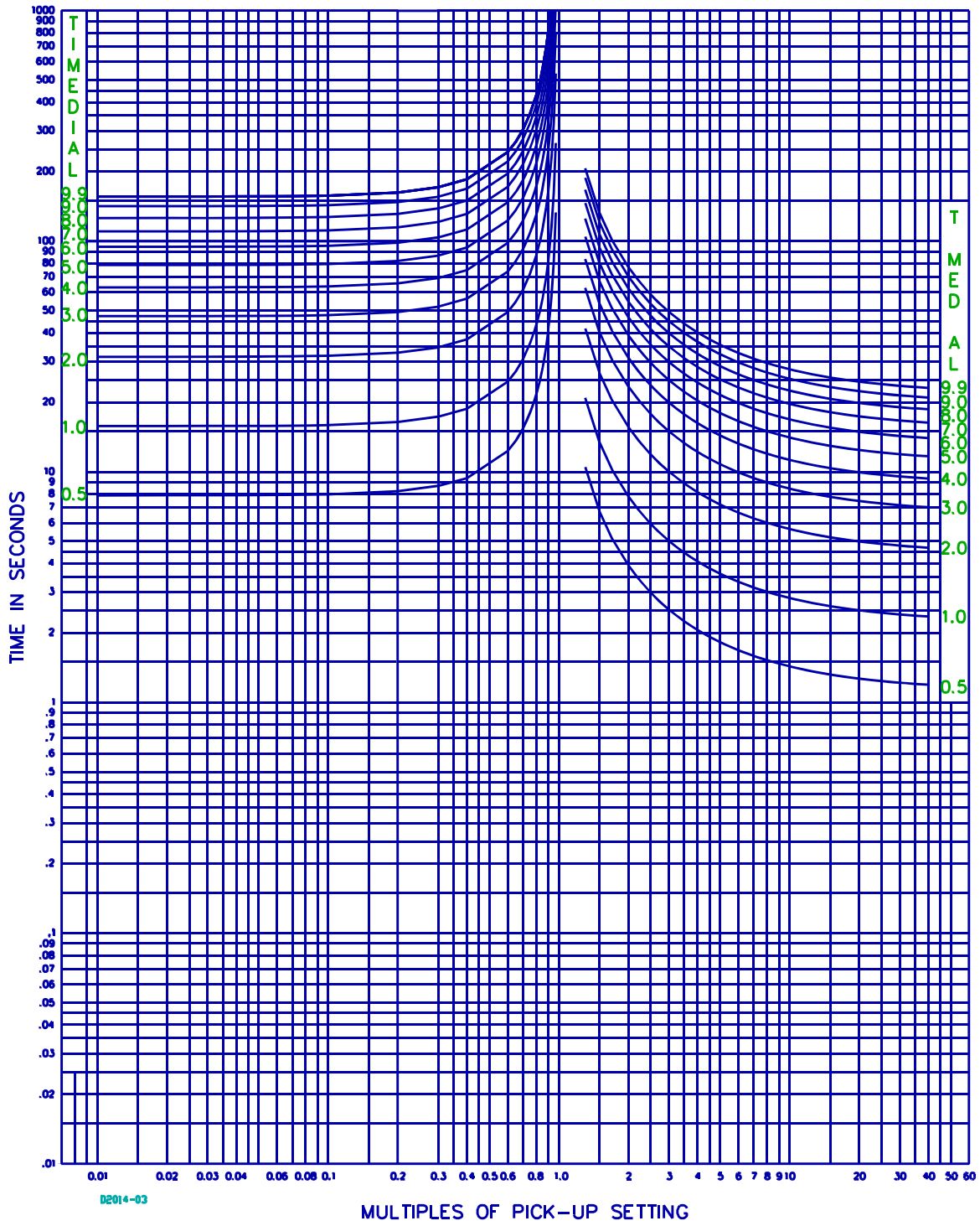

Figure 1-6. Timing Option L, Long Inverse (99-1555)

BE1-DFPR General Information

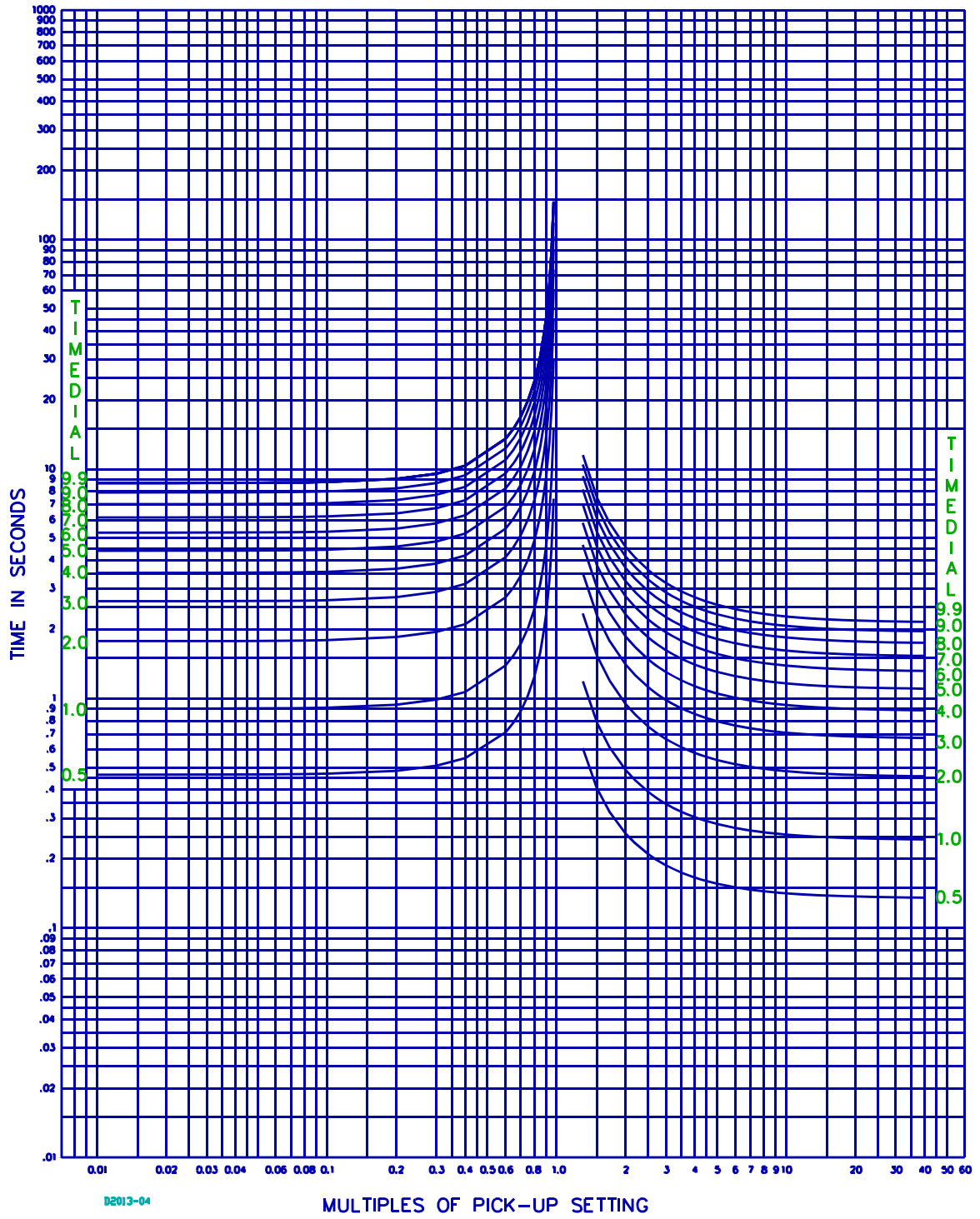

Figure 1-7. Timing Option D, Definite Time (99-1150)

BE1-DFPR General Information

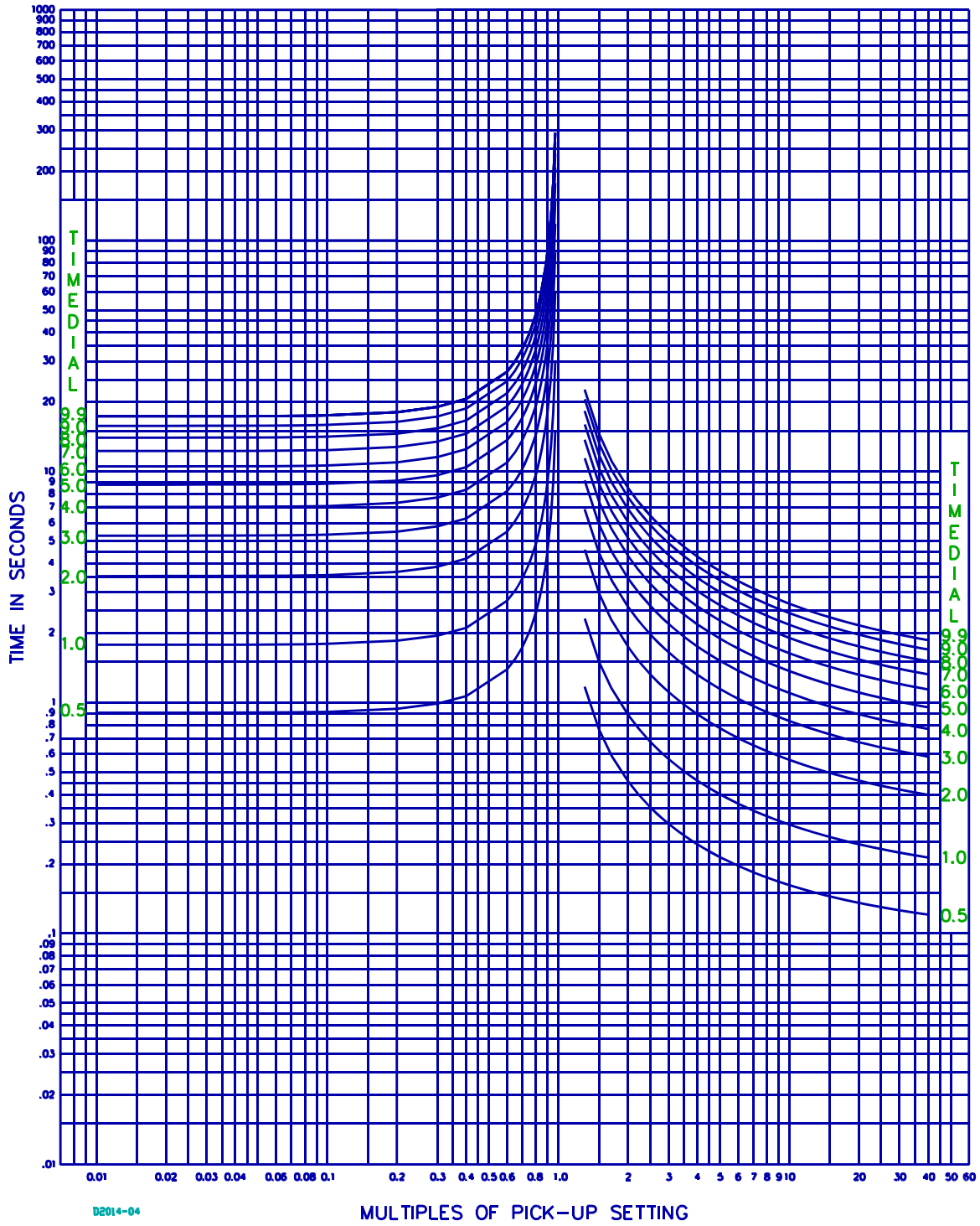
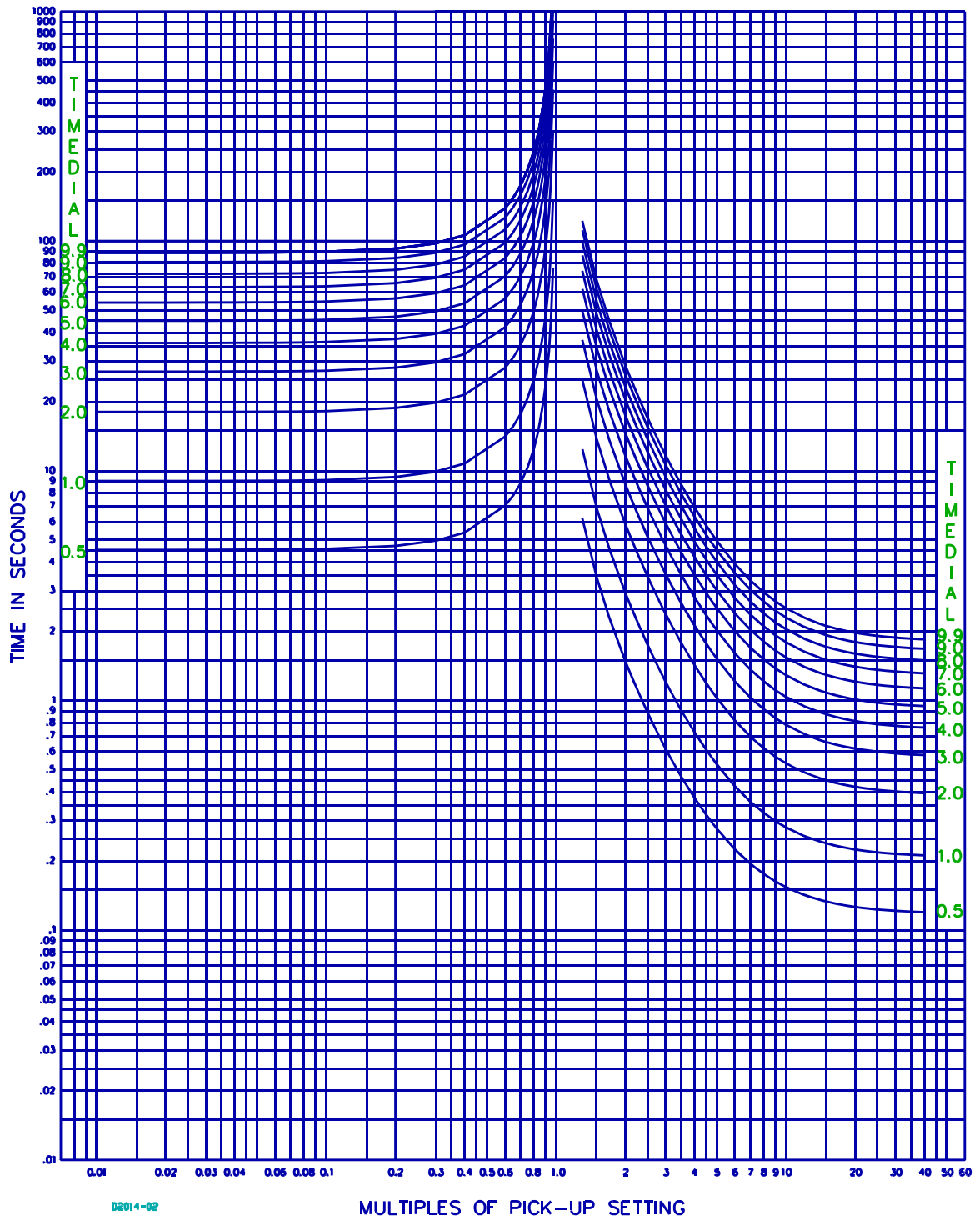

Figure 1-8. Timing Option M, Moderate Inverse (99-1556)

BE1-DFPR General Information



D2014-02

Figure 1-9. Timing Option I, Inverse (99-1554)

BE1-DFPR General Information

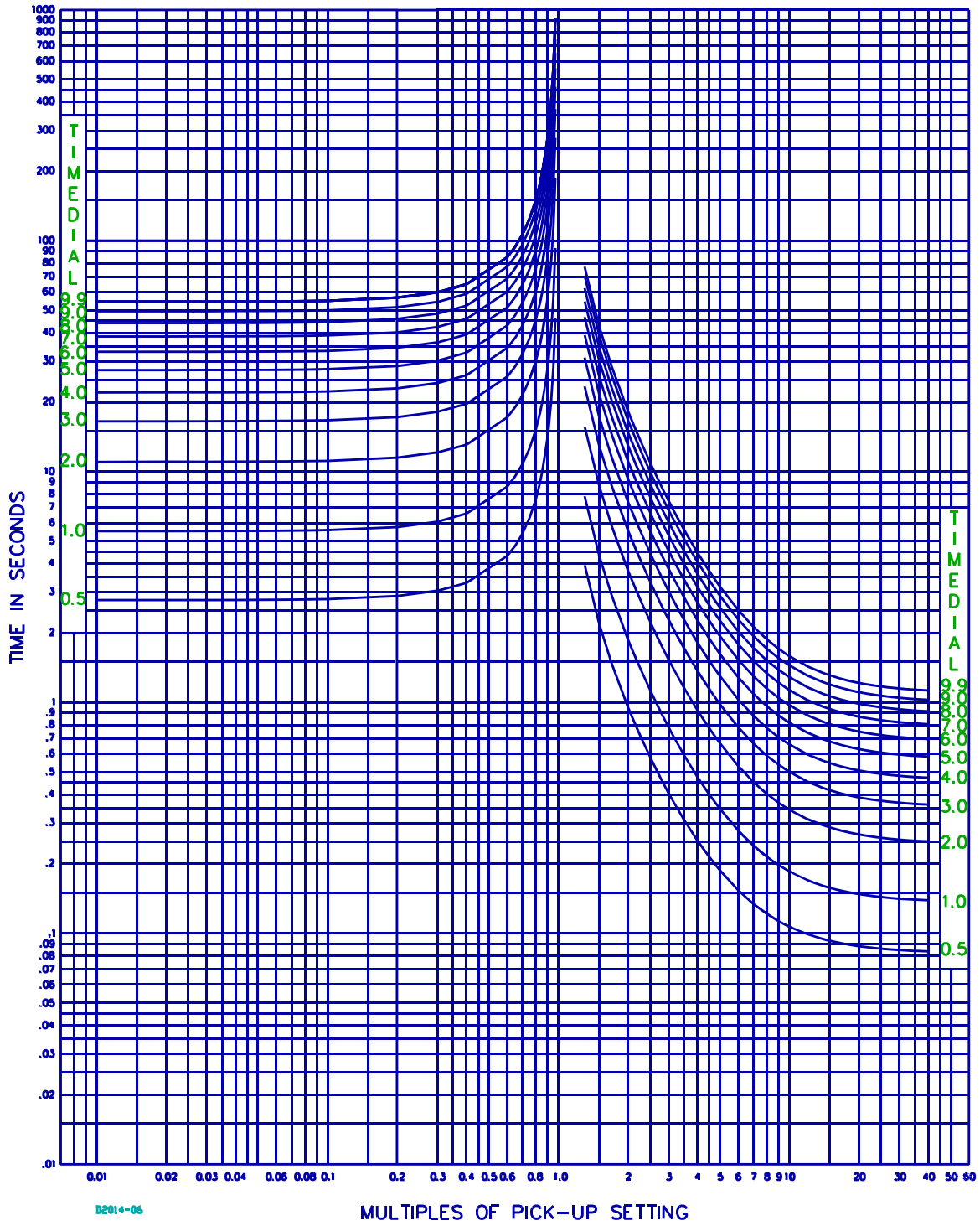

Figure 1-10. Timing Option V, Very Inverse (99-1558)

BE1-DFPR General Information

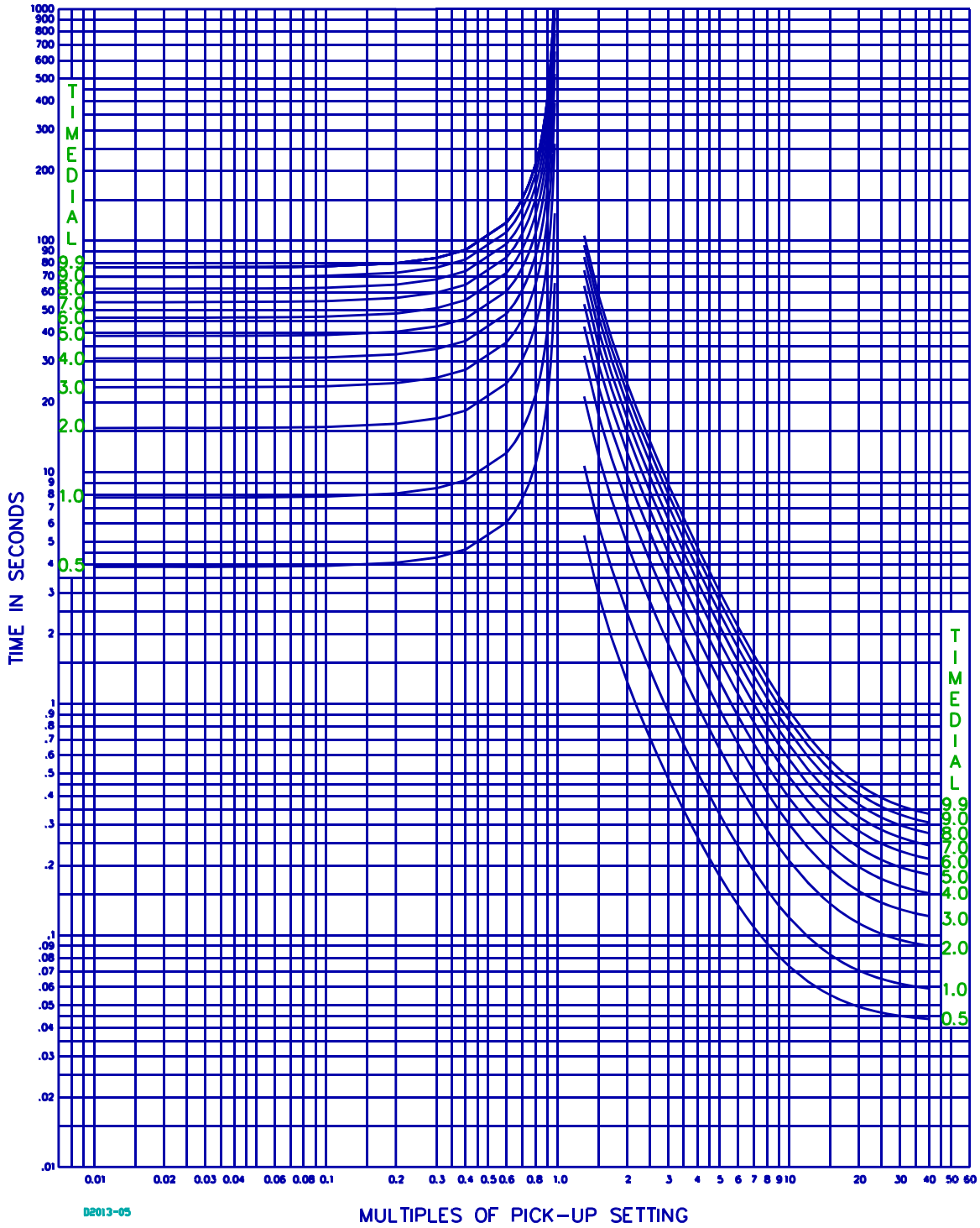

Figure 1-11. Timing Option E, Extremely Inverse (99-1551)

BE1-DFPR General Information

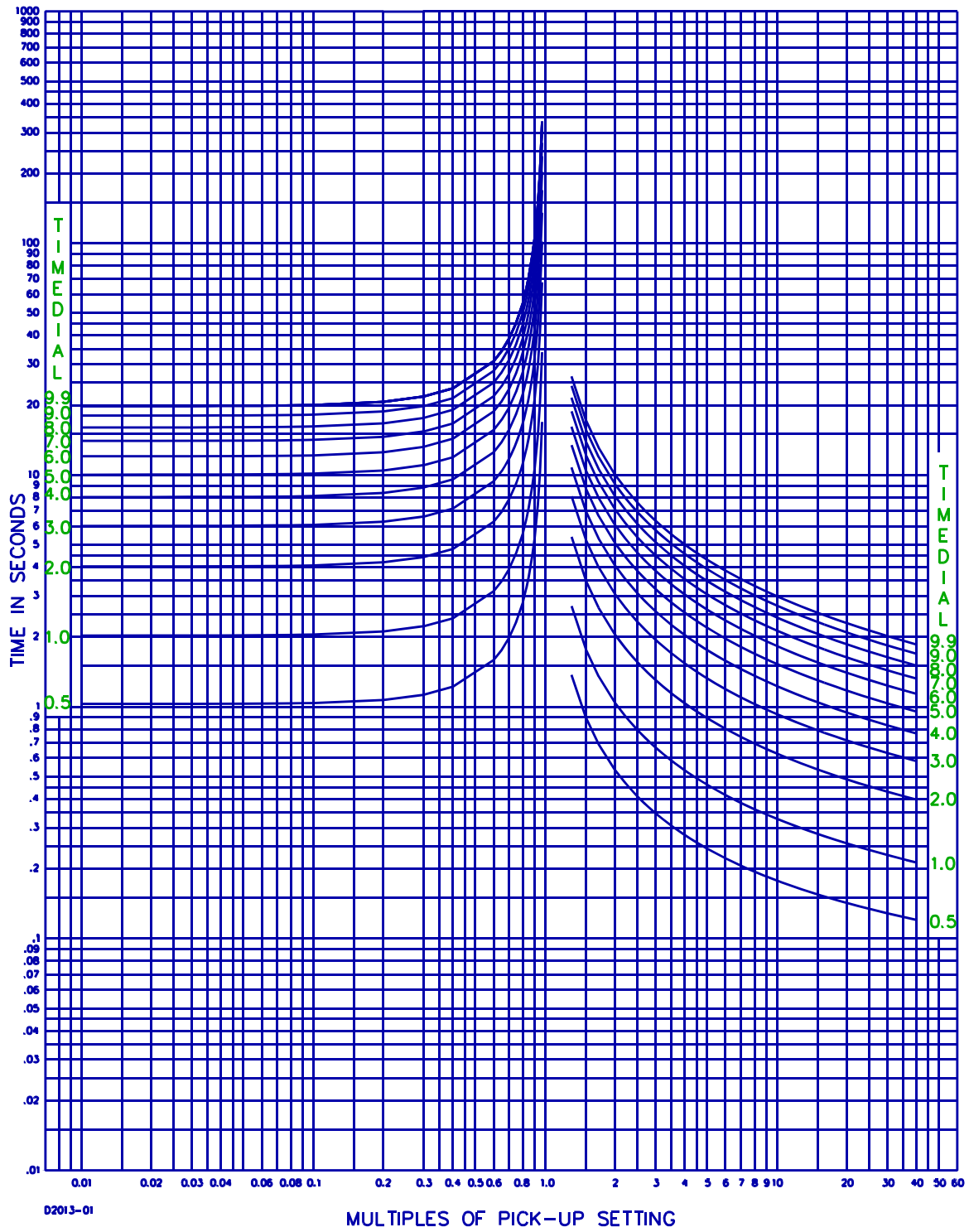

Figure 1-12. Timing Option A, BS 142 Standard Inverse (99-1547)

BE1-DFPR General Information

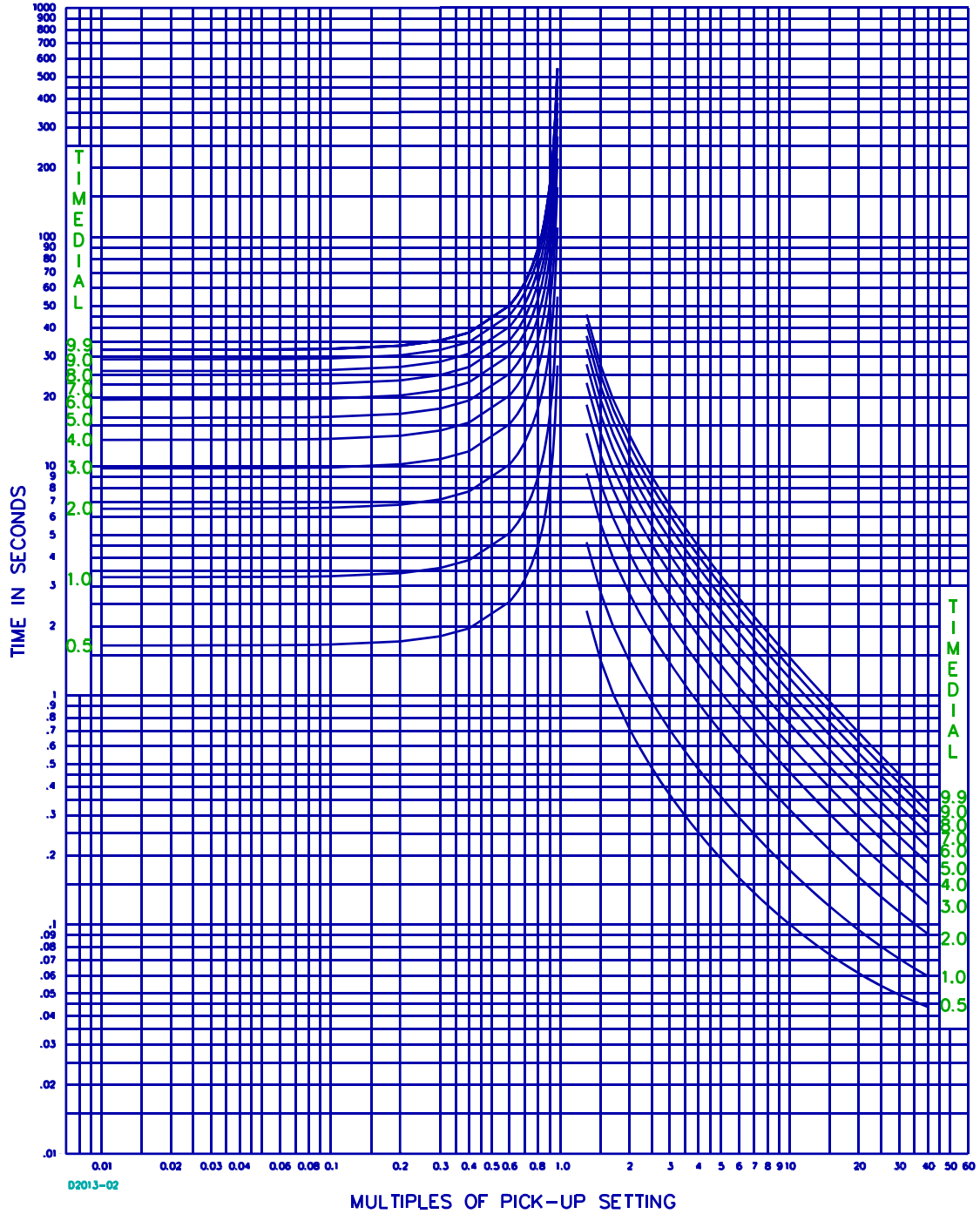

Figure 1-13. Timing Option B, BS 142 Very Inverse (99-1548)

BE1-DFPR General Information

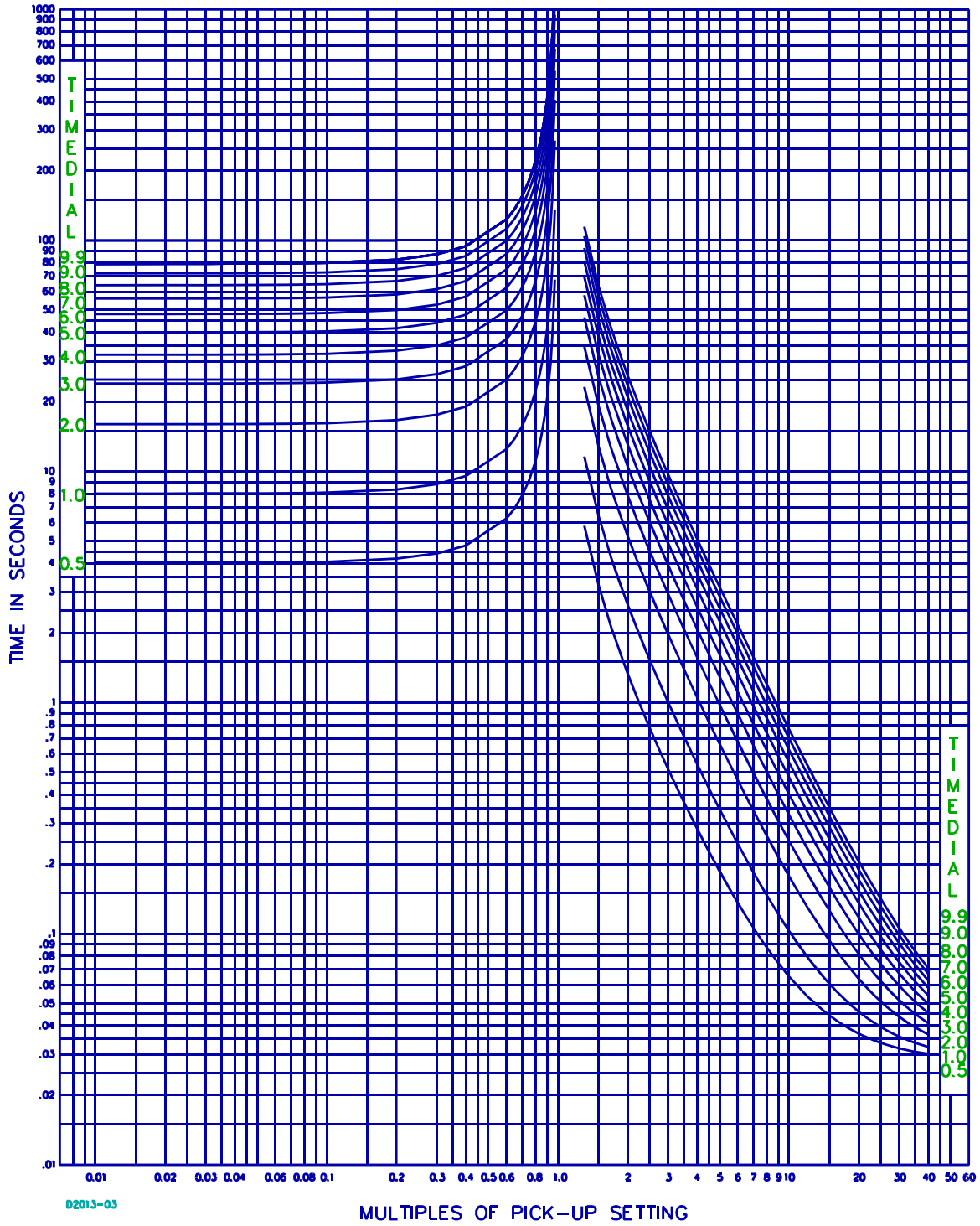

Figure 1-14. Timing Option C, BS 142 Extremely Inverse (99-1549)

BE1-DFPR General Information

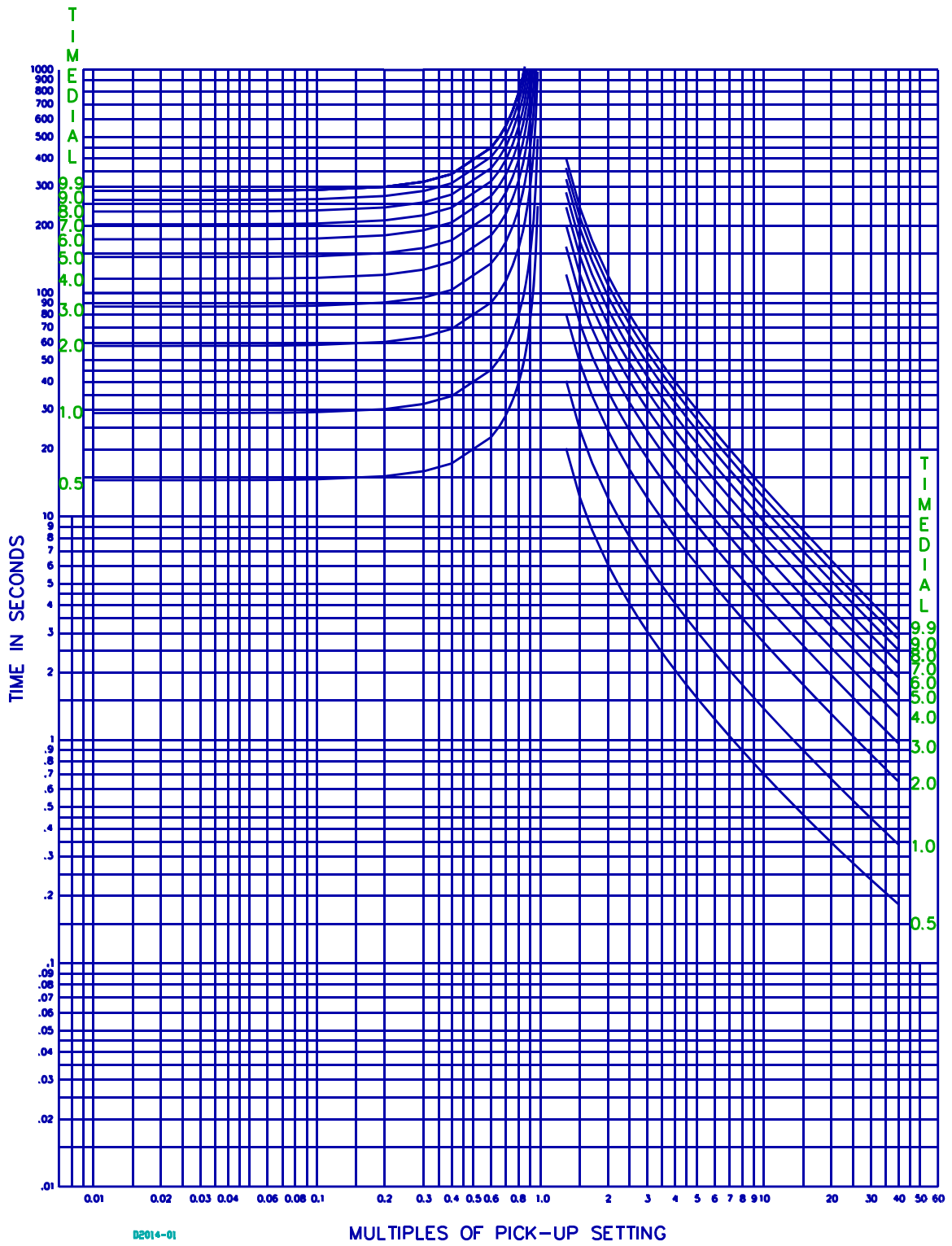

Figure 1-15. Timing Option G. BS 142 Long Time Inverse (99-1553)

BE1-DFPR General Information

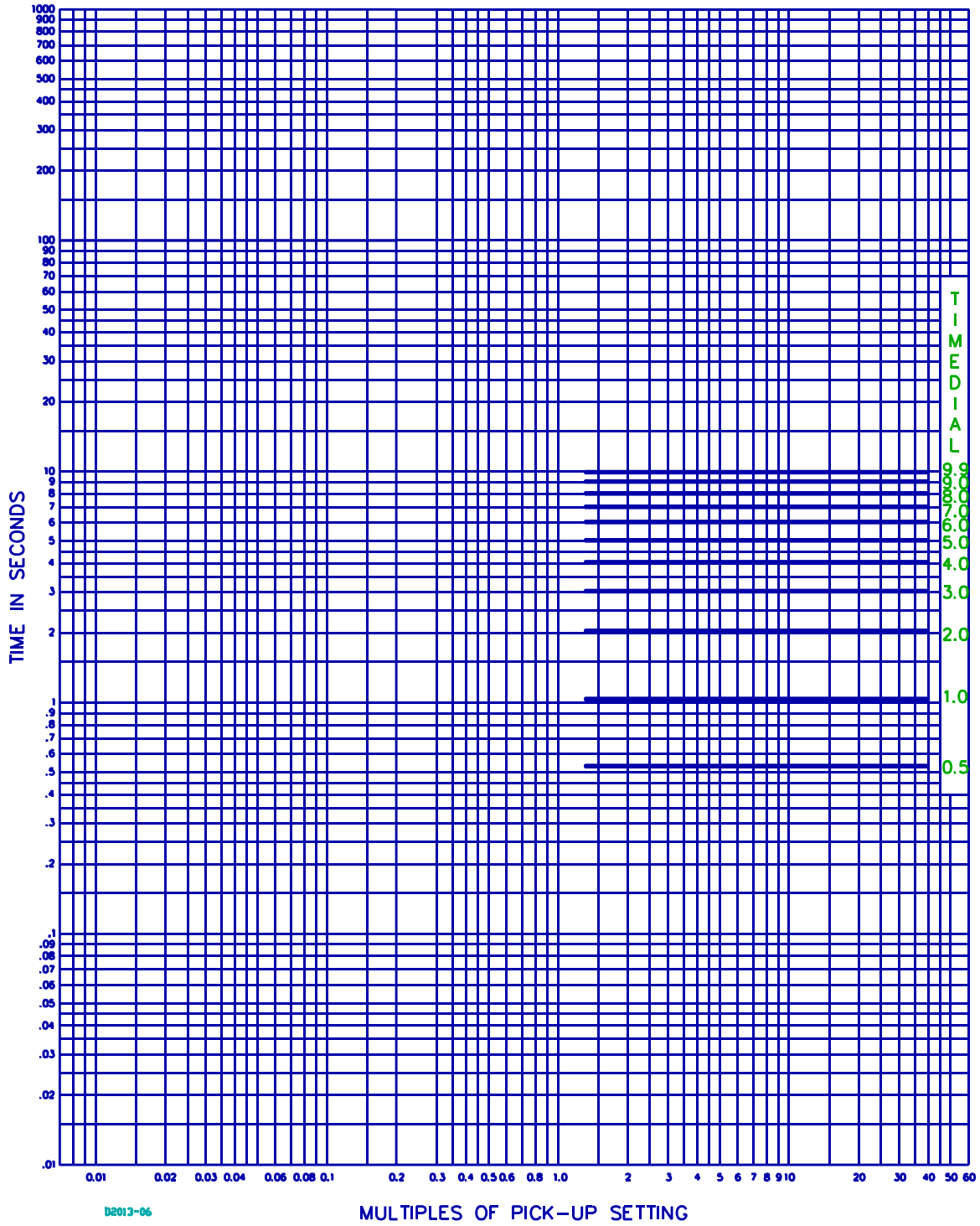

Figure 1-16. Timing Option F, Fixed Time (99-1552)

SECTION 2

CONTROLS AND INDICATORS

LOCATION OF CONTROLS AND INDICATORS

The BE1-DFPR, horizontal mount is shown in Figure 2-1, and the BE1-DFPR, vertical mount is shown in Figure 2-2. A description and an illustration of the controls and indicators for the Control Module, Contact Sense Module, and Magnetics Module is provided in the following paragraphs. Only the horizontal mount modules are illustrated because each control or indicator is the same in the vertical mount units except for the placement. Refer to Figure 2-2 to see the vertical mount unit control and indicator placement.

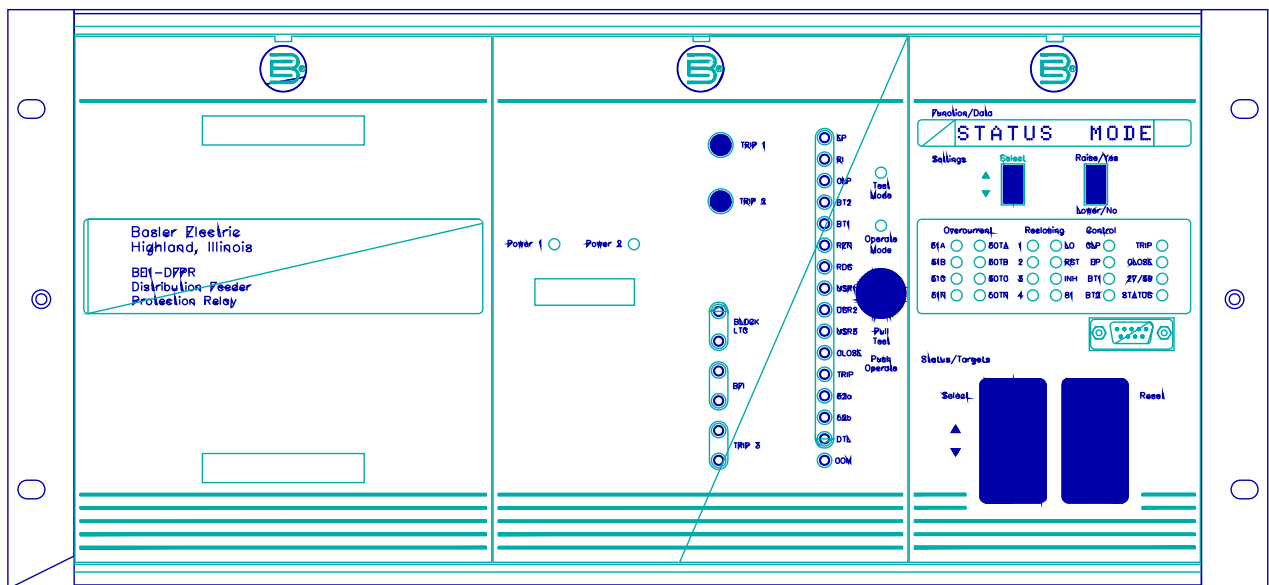

D1856-05
09-05-97

Figure 2-1. BE1-DFPR, Horizontal Mount

BE1-DFPR Controls and Indicators

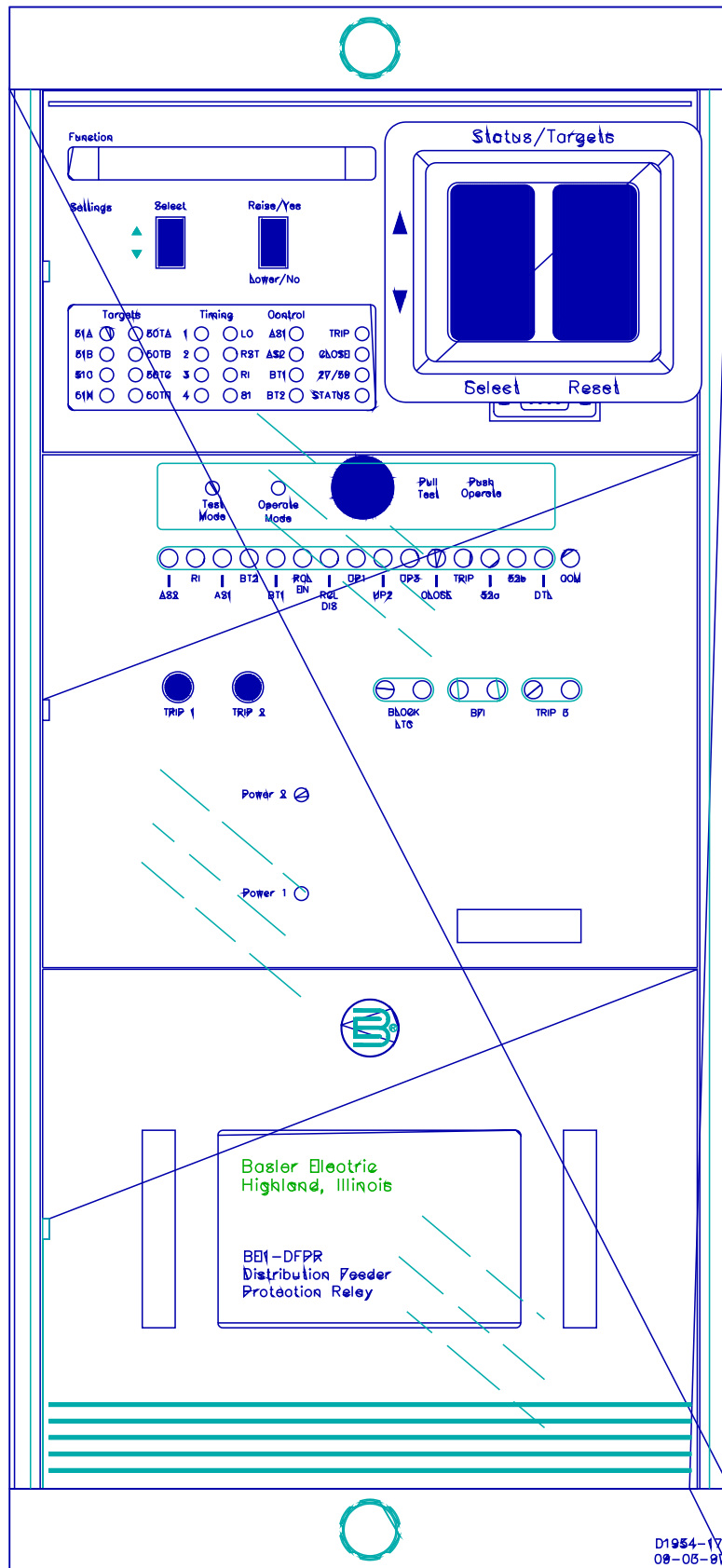

Figure 2-2. BE1-DFPR, Vertical Mount

BE1-DFPR Controls and Indicators

CONTROL MODULE (Figure 2-3)

Function/Data One line, 12 character display to monitor function status and settings.

Status/Targets

Reset Resets targets in display window and the two electromechanical front panel targets (TRIP 1 and TRIP 2) mounted on the relay module assembly behind the contact sense front panel. A target reset is only allowed after all display target events have been displayed on the Function/Data display.

Select Selects Status/Targets display.

Settings

Raise/Yes Lower/No Increases or decreases setting displayed on front panel display while in the Settings mode.

Select Selects front panel display Settings mode to show and/or modify all normal settable parameters.

Overcurrent Eight LEDs indicate sensed 51 timed or 50 timed overcurrent faults.

Reclosing Six LEDs indicate reclosing event (1, 2, 3, or 4), lockout (LO), or reset (RST).

One LED indicate reclosing Inhibit (INH) and one LED indicates underfrequency timing and pick up (81).

Control Four LEDs indicate cold load pickup (CLP or auxiliary settings #1), emergency pick up (EP or auxiliary settings #2), block trip 1 (BT1), or block trip 2 (BT2).

Two LED's indicate status of the TRIP 1 and CLOSE 1 output relays (TRIP and CLOSE). One LED indicates under/OVERvoltage timing and pickup (27/59) and one LED indicates relay status. When status LED is OFF, indicates relay is operating normally. When status LED is ON, indicates a self test fault has been detected. When status LED is flashing ON and OFF, indicates relay is in a Settings mode of operation and reclosing is disabled.

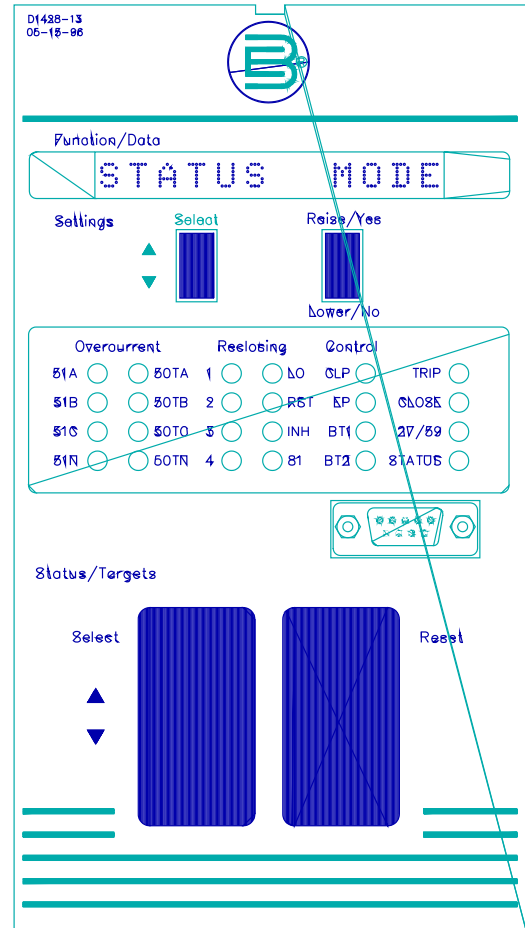

Figure 2-3. Control Module, Front Panel, Horizontal Mount

COMMUNICATIONS Front panel mounted receptacle for connecting RS-232 communications link.

CONTACT SENSE MODULE (Figure 2-4)

Pull Test Switch Relay is in normal operation when Pull Test Switch is pushed in and Operate Mode LED is lit. Relay is in test mode when Pull Test Switch is pulled out and the Test Mode LED is lit.

TEST POINTS There are 15 test point jacks that accommodate standard 0.080 inch diameter phone

BE1-DFPR Controls and Indicators

tip plugs. These test points (15 sense inputs and one common) provide sense input signal monitoring during normal operation and signal injection during test mode operation.

Test Mode/
Operate Mode

During test mode, the test points can be used to insert contact sensing inputs into the relay circuitry. In operate mode (TEST/OPERATE knob pushed in), external contact sensing inputs are connected to the contact sense module and front panel test points. In test mode (TEST/OPERATE knob pulled out), external sensing inputs are disconnected from the contact sense module. An external power source equal to the power supply input can be connected (+ to selected test point input and - to COM test point) to test the contact sensing inputs from these front panel test points.

Test Points

Six test points (BLOCK LTC, BFI, and TRIP 3) provide output relay monitoring during normal operation and test mode.

Targets

TRIP 1 and TRIP 2 targets are electromechanical targets that are latched when current flows in the trip circuit. The targets remain latched until reset by the control module Status/Targets Reset switch.

Power LED

Green LED is ON when the power supply 1 or 2 (Power 1 and Power 2) is operating normally.

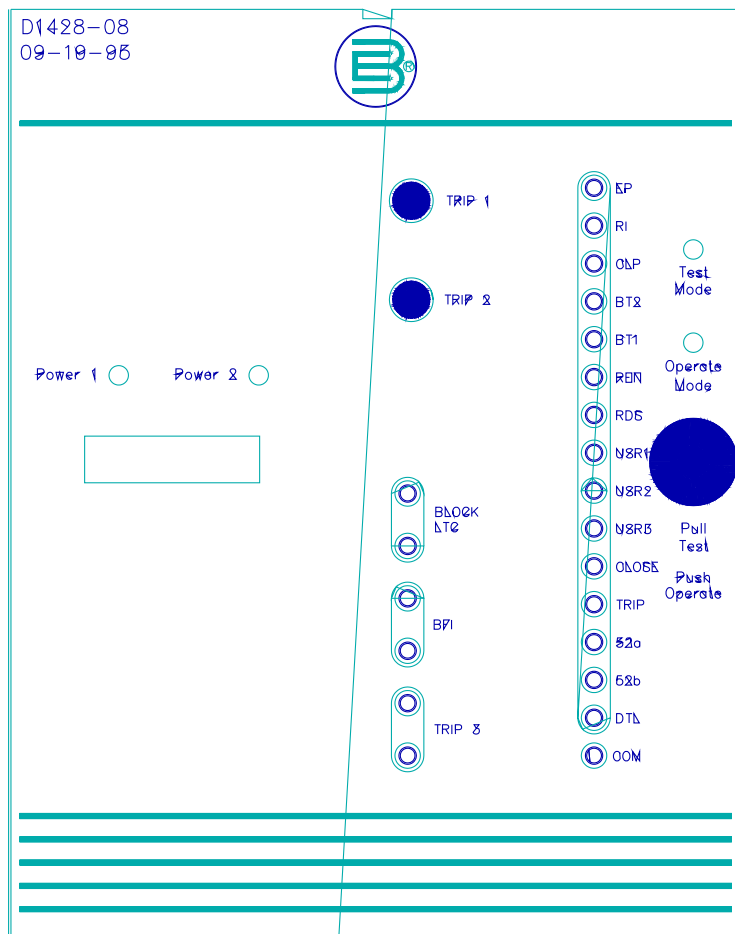

Figure 2-4. Contact Sense Module, Front Panel Horizontal Mount

MAGNETICS MODULE (Figure 2-5)

Input transformers in the magnetics module isolate the relay from the system and step down the currents and voltages to the levels the internal circuits require. A switch located behind the magnetics front panel is provided to connect the voltage transformers in a wye or delta configuration. (Refer to Figure 2-6 for a cutaway view of the switch.)

If four wire, line to neutral voltages are used, the wye/delta switch must be in the **wye** position. If three wire, line to line voltages are used, the switch must be in the **delta** position. If two wire, phase B, line to neutral voltage is used, the switch must be in the **wye** position.

If the switch position is changed, the corresponding **3/1 PH WYE/DELTA** setting in the INSTALLATION SETTINGS screen must also be changed. In the INSTALLATION SETTINGS screen, use setting **1** when the **wye** position is selected for single-phase operation. Use setting **2** when the **delta** position is selected, and setting **3** when the **wye** position is selected for three-phase operation. Refer to the **INSTALLATION SETTINGS** screen under REVIEW/EDIT SETTINGS menu as described in publication 9 2315 00 991, *Terminal Displays and Settings*.

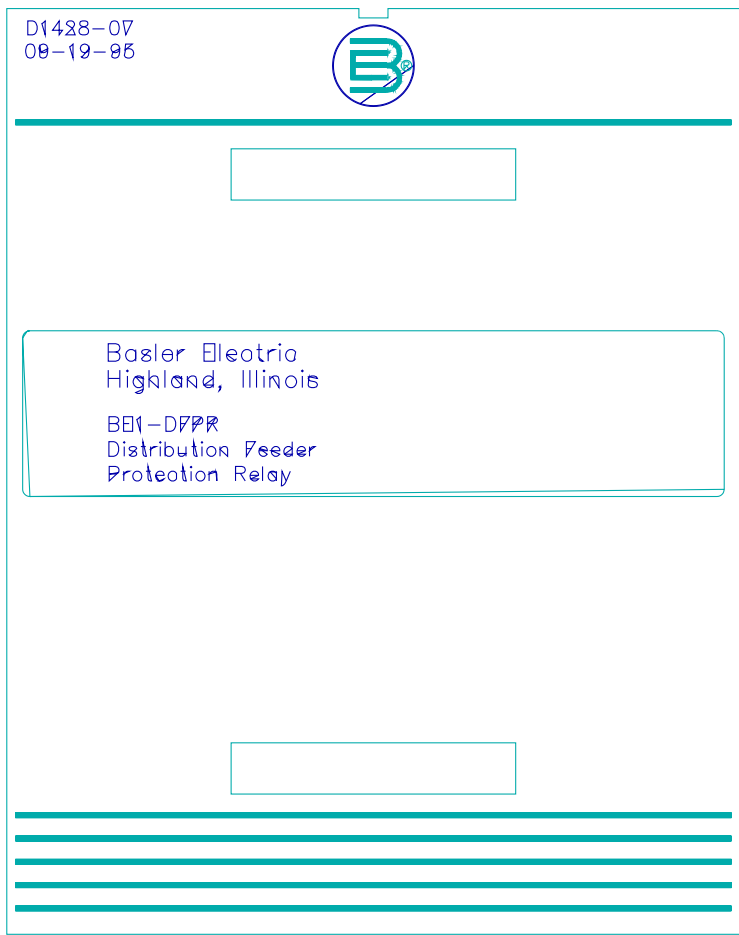

Front panel connection plugs are optional items. When present, connection plugs are accessed by removing the magnetics module front panel. To remove the magnetics module front panel, place a flat blade tool in the notch at the top of the panel. Pry the panel outward until the panel snaps out, and then lift the panel up and away from the relay case.

Current and voltage inputs and control outputs can be tested by removing the connection plugs and replacing them with test plugs (Basler part number 10095 or G.E. model XLA 12A). Doing this disconnects these inputs and outputs from the relay internal circuits. With the test plugs installed, test inputs can be injected, and the relay trip and close outputs can be monitored.

Figure 2-5. Magnetism Module, Front Panel Horizontal Mount With Connection Plugs

BE1-DFPR Controls and Indicators

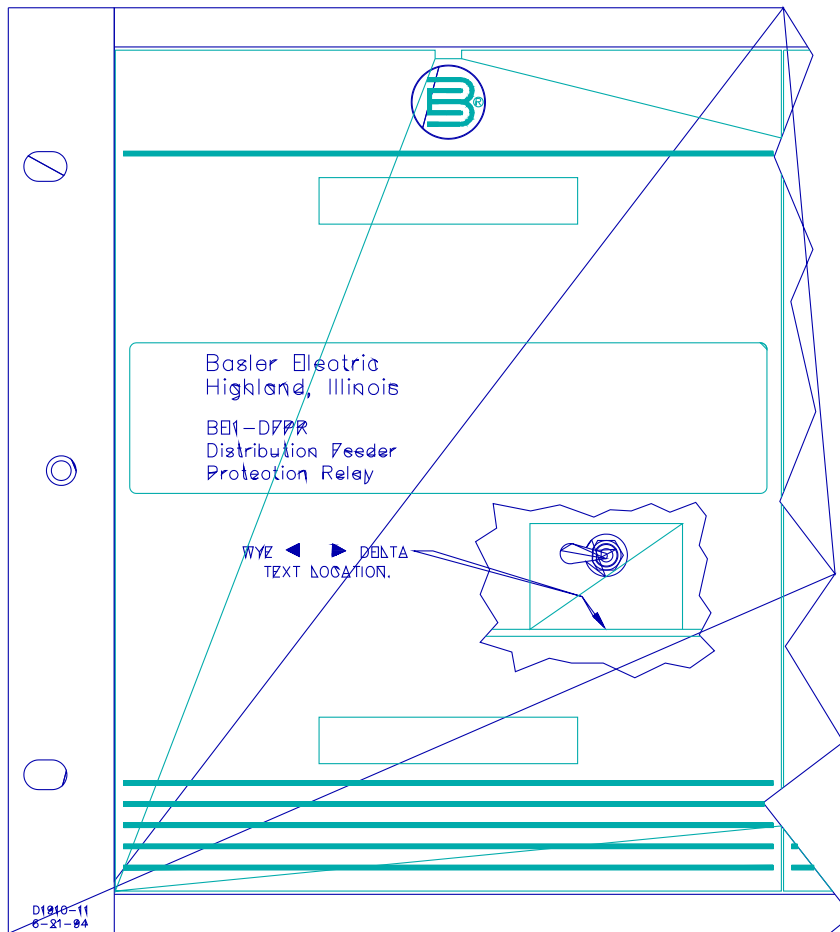

Figure 2-6. Wye/Delta Switch Location In Magnetics Module, Horizontal Mount

BE1-DFPR Controls and Indicators

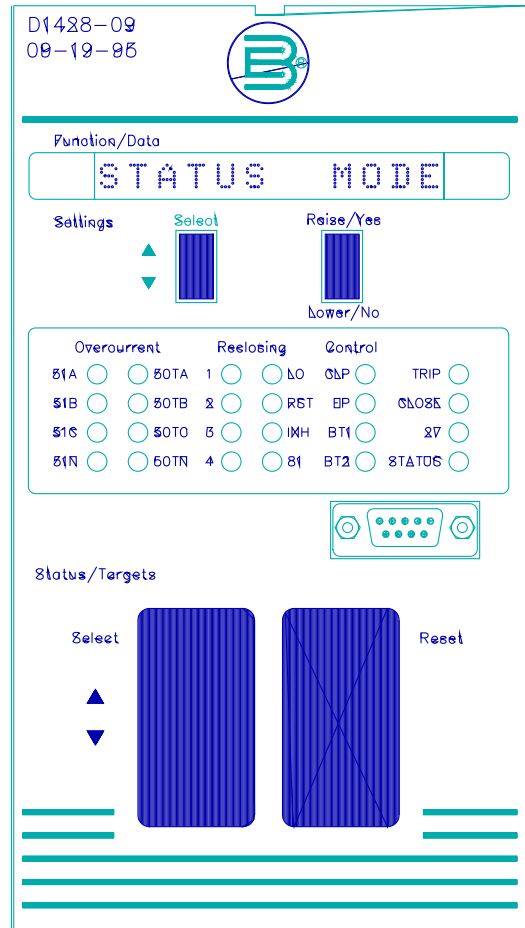

Figure 2-3. Control Module, Front Panel, Horizontal Mount

SECTION 3

FUNCTIONAL DESCRIPTION

GENERAL

BE1-DFPR relays are multi-phase, multi-function, microprocessor based relays. A functional description is provided for each BE1-DFPR function and refers to the functional block diagram, Figure 3-1.

BLOCK DIAGRAM ANALYSIS

General

External contact inputs (control inputs) are routed through an optional test panel module if the test panel module is present. Note that all external control inputs are isolated from the relay electronics with opto-isolators. Outputs from the contact sense module occur on the data bus when the proper signals appear on the address and control buses.

AC inputs from the system current and potential transformers are routed through standard connection plugs to the magnetics module. These inputs consist of 4 currents and 3 voltages that are scaled and isolated with the current and voltage transformers in the magnetics module. Outputs from the magnetic module are connected to the microprocessor data acquisition module. This module converts the analog signals to digital form and performs all protective functions. Trip signals are passed over the data bus to the output relay module as long as they have not been blocked by the control module. Analog values and target information are passed over the serial data link to the control module.

The microprocessor control module processes the serial data from the data acquisition module for all instrumentation and data logging functions. It also provides communications through the front and rear RS-232-C ports and interfaces with the front panel display controls and indicators. All control functions other than trip are also provided by this module.

Two power supplies are shown in the block diagram. Only one is required to power the DFPR. The second one is optional and provides redundancy for users requiring that function.

Current Inputs

Connections are provided for phase and neutral currents on terminals 13A through 20A. These inputs connect to the relay through the top connection plug in the case.

Voltage Inputs

Connections are provided for three wire delta or four wire wye inputs on terminals 7A through 10A. These inputs connect to the relay through the bottom connection plug in the case.

Trip Outputs

Two isolated sets of trip contacts are provided on terminals 1A, 2A and 5A, 6A. When a trip occurs, one or both of the outputs open if selected using the TRIPPING LOGIC screens (2, 5, 8, I, and L) under REVIEW/EDIT SETTINGS menu as described in publication 9 2315 00 991, *Terminal Displays and Settings*. These outputs connect to the relay through the bottom connection plug in the relay case if the test module option is selected.

BE1-DFPR Functional Description

Close Outputs

Two isolated sets of close contacts are provided on terminals 3A, 4A and 11A, 12A. When a reclose occurs, one or both of the outputs close if selected using the RECLOSE LOGIC screens (3, 6, 9, J and M) under REVIEW/EDIT SETTINGS menu as described in publication 9 2315 00 991, *Terminal Displays and Settings*. The first set connects to the relay through the bottom connection plug in the case, and the second connects to the relay through the top connection plug if the test module option is selected.

Control Inputs

Control input connections are made on terminals 5 through 11 and 26 through 33. All inputs should be connected to external wet contacts. A common return (minus) for all inputs is provided on terminal 12. Control inputs make connections to the relay through the optional test module. Control input functions and the appropriate terminals (indicated in parenthesis) are as follows:

- RCL DIS (5) Apply momentary input to disable reclosing. This input has priority over a reclose enable input.
- RCL EN (6) Apply momentary input to enable reclosing.
- BT1 (7) Block trip #1. Apply input to block tripping by the neutral instantaneous, neutral fixed time, and neutral time overcurrent elements (50N, 50TN, and 51N).
- BT2 (8) Block trip #2. Apply input to block tripping by all fixed time overcurrent elements (50TA, 50TB, 50TC and 50TN).
- RI (10) Reclose Initiate or block. Apply input to allow automatic reclosing. Remove input to block.
- 52 Trip (30) Apply input to issue a trip output. Momentary inputs cause the TRIP1 contacts to close for a minimum of 200 milliseconds. This input will not initiate reclosing and will put the reclosing section in lockout mode. This input has priority over 52 close.
- 52 Close (29) Apply input to issue a close output. Momentary inputs cause the CLOSE1 contacts to close for a minimum of 200 milliseconds.
- 52a (31) Connect to the 52a contact in the breaker and return the other side of the contact to the plus side of the control voltage. This input is used in conjunction with the breaker fail alarm functions. Sensing this input may be disabled from the INSTALLATION SETTINGS screen under REVIEW/EDIT SETTINGS menu as described in publication 9 2315 00 991, *Terminal Displays and Settings*.
- 52b (32) Connect to the 52b contact in the breaker and return the other side of the contact to the plus side of the control voltage. This input is used in conjunction with the breaker fail/alarm functions.
- DTL (33) Drive to lockout. Apply input to put the reclosing function into the lockout condition.

User Programmable Inputs

There are five user programmable inputs. The available selectable functions for these programmable inputs are:

- RESET MIN/MAX DEMANDS
- DISABLE 81 RESTORE
- RESET TARGETS
- ENABLE NORMAL SETTINGS
- ENABLE AUX2 SETTINGS
- ENABLE AUX4 SETTINGS
- TRIGGER EVENT CAPTURE
- DISABLE ZONE SEQUENCE
- RESET WATT-VAR HOURS
- ENABLE AUX1 SETTINGS
- ENABLE AUX3 SETTINGS

These functions are selected from the PROGRAMMABLE INPUTS screen under REVIEW/EDIT SETTINGS menu as describe in publication 9 2315 00 991, *Terminal Displays and Settings*. The five user programmable inputs and the default settings are:

- USR 1 (26) User programmable input #1. Default setting is trigger event **Capture**.
- USR 2 (27) User programmable input #2. Default setting is **Reset** targets.

BE1-DFPR Functional Description

- USR 3 (28) User programmable input #3. Default setting is **Enable** normal settings.
- USR 4/ CLP (9) User programmable input #4. (Cold load pickup). Default setting is **Enable** Aux 1 settings.
- USR 5/EP (11) User programmable input #5. (Emergency pickup). Default setting is **Enable** Aux 2 settings. Aux 2 setting has priority over Aux 1 (cold load), Aux 3, and Aux 4 settings.

Control Outputs

Separate pairs of isolated contacts for control purposes are provided on terminals 36 to 41. The control outputs and the appropriate terminals (indicated in parenthesis) are as follows:

- BFIO (36-37) BFIO (breaker fail initiate output, labeled BFI on front panel output test points and rear panel output contacts). This contact closes if the breaker fails to open after receiving a TRIP1 command from one or more of the protective elements (or through the supervisory input) after the BF TD has expired as specified during the setup for this function.

NOTE

The BFI output will NOT occur if the trip command is only through the TRIP2 output.

- BLTC (38-39) BLTC (block load tap change). BLTC output contact blocks the operation of a load tap changer or voltage regulator during the fault clearing and restoration process.
- PT (40-41) PT (programmable trip). PT contact may be programmed by the user to close for any combination of trip conditions for all protective elements.

Target Outputs

Seven contacts (labeled 0, 1, 2, 3, 4, 5, and 6) with a common connection provide target/status information. The common connection is on terminal 13. Terminals 14-20 are connected to the output contacts. The targets are programmable for 50 A, 50B, 50C, 50N, 50TA, 50TB, 50TC, 50TN, 51A, 51C, 51N, 81, 27/59, and BF elements. These are used to indicate the type of fault. Other status indicators are also programmable for the seven target outputs. Indicators such as BT1 enabled, BT2 enabled, normal settings enabled, Aux 1 settings enabled, Aux 2 settings enabled, Aux 3 settings enabled, Aux 4 settings enabled, 79 inhibit, and front panel settings access.

Alarm Outputs

Separate pairs of isolated contacts are provided for 5 alarm outputs. These outputs and the appropriate terminals (indicated in parenthesis) are as follows:

- Prog 1 (21-22), Prog 2 (23-24) Prog (programmable). These alarm outputs may be programmed by the user to operate for one or more conditions established during the setting up process.
- RT (45-46) RT (relay trouble). RT is a relay trouble alarm contact. It closes for failure of the power supply, microprocessor, memory test, A/D converter test, and communications.
- REC LO (47-48) REC LO (reclosing lockout). REC LO contact will close when the reclosing section of the relay is in the lockout condition.
- BF (49-50) BF (breaker failure). BF contact provides an indication that a problem has been detected with the controlled circuit breaker. The contact closes if: 1) a discontinuity is detected in the trip circuit, 2) the 52a and 52b contacts do not agree on breaker position, 3) the breaker did not close within the time set for the reclose fail timer, and 4) breaker operations count reaches the maximum breaker operations count limit.

BE1-DFPR Functional Description

Trip Circuit Sense

Terminals 34 (+) and 35 (-) are connected internally to an optically isolated sense circuit. This feature is used by connecting these terminals across the trip output contacts with terminal 34 connected to the positive side. Lack of continuity in the trip circuit when the breaker is closed will activate the BF alarm and cause the reclosing logic to go to a lockout condition. If this function is NOT to be used, then voltage equal to the control input voltage must be continuously connected to the input terminals. A typical trip circuit sensing (TCS) application is shown in Figure 3-2.

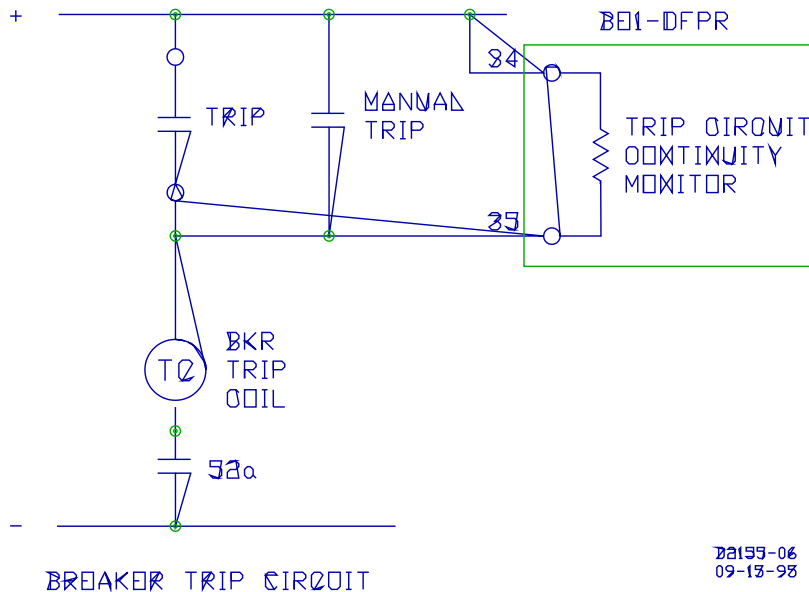

Figure 3-2. Typical TCS Application

Control Power

Separate sets of terminals are provided for the main and optional redundant power supplies. This allows them to be supplied from different power sources if desired. Power supply names are for reference only. Either power supply (main or backup) may be connected to either set of terminals.

Communications

RS-485 connections are on terminals 2 through 4. These connections are for optional special applications and are not activated on the standard product. The standard product communicates through the RS-232-C connectors on the front and rear panels. Connection to the front panel automatically disables the rear port.

MODES OF OPERATION

DFPR relays have two primary modes of operation. They are:

- Status mode
- Settings mode

These modes are selected by momentarily pushing or rocking (either up or down) the front panel Status/Targets select or Settings select switches.

Settings Mode

NOTE

All reclose functions and terminal settings screens are disabled while the DFPR is in the Settings mode. The real time instrumentation screen will indicate **FPSET ACCESS** after **RELAY STATUS**.

To program the normal settings or parameters, select the Settings mode by momentarily pushing or rocking (either up or down) the front panel Settings Select switch. The front panel STATUS LED will flash ON and OFF to indicate the Settings mode has been entered. The STATUS LED will continue to flash while in the Settings mode. Only the normal settings (not auxiliary 1 or auxiliary 2) can be edited from the relay front panel.

To select a setting or parameter, momentarily push or rock (either up or down) the front panel Settings Select switch. Each time the switch is operated, another parameter is selected as the display scrolls through the available front panel settable parameters. These parameters are as follows. Ranges shown are for the five ampere CT sensing input range. One ampere CT sensing input ranges are shown in parenthesis.

BE1-DFPR Functional Description

Display	Description	Range
Address	Remote address for future use	1 - 254
F-KBAUD	232 Front port Communication Baud Rate	300, 600, 1200, 2400, 4800, 9600, 19200
R-KBAUD	232 Rear port Communication Baud Rate	300, 600, 1200, 2400, 4800, 9600, 19200
R485-KB	485 Rear port Communication Baud Rate (optional)	300, 600, 1200, 2400, 4800, 9600, 19200
T-DELAY	DNP Transmission delay (optional)	0 - 65, 535 milliseconds
DL-MODE	DNP Data Link Confirm Mode (optional)	0 - 2
M-RETRY	DNP maximum retries (optional)	0 - 255
DL-TO	DNP Data Link Confirm Time Out (optional)	0 - 65, 535 milliseconds
51P PU	51 Phase A, B, & C pickup	0.5 - 12.0 Amps (0.1 - 2.4 Amps)
51P CURV	51 Phase time curve selection	S, L, D, M, I, V, E, A, B, C, G, and F
51P TD	51 Phase time curve time delay	0.0 - 9.9
51N PU	51 Neutral A, B, & C pickup	0.5 - 12.0 Amps (0.1 - 2.4 Amps)
51N CURV	51 Neutral time curve selection	S, L, D, M, I, V, E, A, B, C, G, and F
51N TD	51 Neutral time curve time delay	0.0 - 9.9
50P PU	50 Phase A, B, & C pickup	0.5 - 150.0 Amps (0.1 - 30.0 Amps)
50N PU	50 Neutral pickup	0.5 - 150.0 Amps (0.1 - 30.0 Amps)
50TP PU	50T Phase A, B, & C pickup	0.5 - 150.0 Amps (0.1 - 30.0 Amps)
50TP TD	50T Phase A, B, & C time delay	0.03 - 5.00 seconds
50TN PU	50T Neutral pickup	0.5 - 150.0 Amps (0.1 - 30.0 Amps)
50TN TD	50T Neutral time delay	0.03 - 5.00 seconds
BF TD	Breaker Failure time delay	0.03 - 0.50 seconds
81 THZ	Underfrequency trip pickup	40.00 - 70.00 Hz
81 TTD	Underfrequency trip time delay	0.10 - 0.50 seconds
81 RHZ	Underfrequency restore pickup	40.00 - 70.00 Hz
81 RTD	Underfrequency restore time delay	1 - 1000 seconds
81 UV	Underfrequency voltage inhibit	40 - 120 volts

Front Panel Display	Description	Range
27 PU	Undervoltage pickup	50 - 120 volts
27 TD	Undervoltage time delay	1 - 1000 seconds
59 PU	Overvoltage pickup	50 - 150 volts
59 TD	Overvoltage time delay	0.0 - 100 seconds
79 1 TD	Reclose time delay #1	0.00 - 100.00 seconds
79 2 TD	Reclose time delay #2	0.00 - 200.00 seconds
79 3 TD	Reclose time delay #3	0.00 - 200.00 seconds
79 4 TD	Reclose time delay #4	0.00 - 200.00 seconds
79 RST	Reclose Reset time delay	1.00 - 200.00 seconds
79 RECF	Reclose Fail time delay	0.0 - 9.9 seconds
79 MAX	Reclose Max cycle time delay	0 - 999 seconds
CT PRI	Primary CT current level	5 - 5000 Amps
CT SEC	Secondary CT current level	1 - 5 Amps
NCT PRI	Primary Neutral CT current level	5 - 5000 Amps
NCT SEC	Secondary Neutral CT current level	1 - 5 Amps
VT PRI	Primary VT voltage level	1 - 65000 volts
VT SEC	Secondary VT voltage level	60 - 130 volts
DEMAND T	Demand Time Interval	1 - 60 minutes
RST DMDS	Reset demand values	Yes - No
TST MODE	Test Mode Entry	Yes - No
CAL MODE	Calibration Mode Entry	Yes - No
YEAR	Year clock setting	00 - 99 years
MONTH	Month clock setting	01 - 12 months
DAY	Day clock setting	01 - 31 days
HOUR	Hour clock setting	00 - 23
MINUTE	Minute clock setting	00 - 59 minutes
SECOND	Second clock setting	00 - 59 seconds

To program a parameter, operate the Settings Select switch until the parameter is displayed. Operate the Settings Raise/Yes Lower/No switch until the setting to be programmed is displayed. Momentarily operating the Settings Raise/Yes Lower/No switch steps the display one digit. Holding the Settings Raise/Yes Lower/No switch up or down will increase the rate of change for the display. To save the newly programmed settings and leave the Settings mode, operate the Status Select switch momentarily. After the switch is operated, SAVE SETUP? is displayed in the window. To complete the save routine, push the Status Select switch up. All parameter settings will be saved. If the Status Select switch is pushed down, the changed settings will not be saved and NOT SAVED will be displayed in the window. If a pickup setting is set to a level that will cause

BE1-DFPR Functional Description

a trip or pickup for existing voltages or current, then NOT SAVED will be displayed followed by the type of protective function that would cause the pickup or trip.

Maximum and minimum demand values for IA, IB, IC, KW, KVAR, and KVA are recorded and saved. Recorded demand values are reset to zero from the front panel while in the Settings mode. Resetting procedures are provided in Section 4. Maximum and minimum demand values may also be reset with one of the user programmable inputs if selected from the PROGRAMMABLE INPUTS screen under REVIEW/EDIT SETTINGS menu as described in publication 9 2315 00 991, *Terminal Displays and Settings*.

From the Settings mode, sensing input circuits and relay output circuits can be tested sequentially or in a programmed automatic sequence (TEST MODE); default settings can be loaded (LOAD DEF S); or the trip output relays can be tested (TEST TRIP). Entry into test mode, load default settings, or test trip is made from the test mode entry parameter (refer to the list of parameters listed in the preceding paragraphs). TEST MODE would normally be used in a bench test environment or a new installation where all sensing input and control output circuits are to be tested and verified. Load default settings is designed to be used during relay testing, but the preprogrammed default settings could be loaded for any specific reason. The automatic sequence of test mode and the default settings are controlled by preprogrammed (firmware) instructions. Test trip only tests the trip output relay (TRIP 1) and associated trip output relay circuits. Test trip could be used in a system installation where the trip output circuits are to be tested.

Status Mode

Status mode is entered after power-up or when the front panel Status Select switch is operated. After entering Status mode, the state of the controlled breaker is monitored.

Operating the Status Select switch will step the display through different active parameters. Holding the Status Select switch up or down will scroll the display through the parameters.

The displays are:

- Targets (50, 50T, 51, 81, 27, 59, BF) If no faults have occurred, **NO TARGETS** is shown on the display. If all three overcurrent types of faults have occurred, then each target type is displayed in turn with the appropriate phase or neutral shown on the display. If a 50 fault occurred with all three phases and neutral faulted, the display would show **TARG 50 ABCN**. If a 50 fault occurred with phases A, C, and neutral faulted, the display would show **TARG 50 A CN**. If a 27 target has occurred, the display will show **TARG 27**. If a 81 target has occurred, the display will show **TARG 81**. If a breaker failure has occurred, the display would show **TARG BF**. If a fault has occurred, the letter F will follow the current and voltage inputs (i.e. — IAF, IBF, ICF, INF, VAF, VBF, or VCF) and only the last fault values will be displayed until targets are reset).
- IA, IB, IC, and IN - primary current levels
- VA, VB, VC, - primary voltage levels
- KW, KVR, and KVA - power levels WATTS, VARS, and VA
- FREQ - system frequency in Hz
- PF - phase B power factor
- AD, B, C, DKW, DKVR and DKVA - demand readings for IA, IB, IC, KW, KVAR, and KVA
- ADM, ADm BDM, BDm, CDM, CDm, DM KW, Dm KW, DM KVR, Dm KVR, DM KVA, and Dm KVA - Maximum and minimum demand readings for IA, IB, IC, KW, KVAR, and KVA.
- Date
- Time

AUXILIARY SETTINGS

Auxiliary settings provide a means of changing the relay philosophy for a predictable situation such as cold load pickup or hot-line maintenance where the setting philosophy is intended to protect personnel rather than the line. Auxiliary settings are set from the communications port using the Aux 1, Aux 2, Aux 3, and Aux 4 MODE SETTINGS screens under the REVIEW/EDIT SETTINGS menu as described in publication 9 2315 00 991, *Terminal Displays and Settings*. Auxiliary settings are **NOT** available from the front panel settings mode. Only the normal settings group can be edited from the front panel settings mode.

In addition to the normal operational settings for distribution circuit protection, the BE1-DFPR can program settings for additional tripping schemes. Each of these schemes is user definable in terms of pickup settings for elements, the operation of each tripping element, and the response of the reclosing section. These distinct settings are defined by the user and enabled by an external contact closure (possibly from the SCADA system). Auxiliary settings are enabled by the closure of the user programmable inputs. Aux 2 settings take precedence over other selected auxiliary settings.

BE1-DFPR Functional Description

Auxiliary Setting 1 (CLP)

Auxiliary setting 1 is enabled when the selected user programmable contact sensing input is momentarily closed. When auxiliary setting 1 is enabled, the reclosing logic goes to LOCKOUT. Before the reclosing logic can return to RESET, the 79 reset timer must time out with the breaker closed. If desired, auxiliary setting 1 can be automatically enabled if the breaker stays open longer than the auxiliary 1 set time. Auxiliary 1 set time may be changed or disabled from the communication port using the INSTALLATION SETTINGS screen under the REVIEW/EDIT SETTINGS menu as described in publication 9 2315 00 991, *Terminal Displays and Settings*.

To exit auxiliary settings 1 with the desired new settings, the selected user programmable contact sensing input must be momentarily closed. If auxiliary setting 1 was entered automatically via the auxiliary 1 set time, then the breaker must remain closed for ten minutes for the relay to return to normal settings.

Auxiliary Setting 2 (EP), 3, And 4

Auxiliary setting 2 has priority over all other Auxiliary settings. Auxiliary settings 2, 3, and 4 are enabled when the selected user programmable contact sensing input is momentarily closed. When the auxiliary setting is enabled or disabled, the reclosing logic goes to LOCKOUT. No automatic mode exists for auxiliary 2 setting. To exit the auxiliary settings mode with the desired new settings, the selected user programmable contact sensing input must be momentarily closed.

OVERCURRENT PROTECTION

Sensing Configurations

- Three Phase and Neutral currents
- The relay is available with a choice of three voltage sensing configurations:
 - Three-phase, four wire wye
 - Three-phase, three wire delta
 - Single-phase using phase B voltage and current

BE1-DFPR relays include three independent overcurrent functions for each sensed current input:

Time Overcurrent (51, 51N)

- Phase settings adjustable over the range of 0.5 to 12 amperes in 0.1 ampere increments for a 5 ampere sensing input range and 0.1 to 2.4 amperes in 0.02 ampere increments for a 1 ampere sensing input range.
- Neutral settings adjustable over the range of 0.5 to 12 amperes in 0.1 ampere increments for a 5 ampere sensing input range and 0.1 to 2.4 amperes in 0.02 ampere increments for a 1 ampere sensing input range.
- Independent Phase and Neutral Timing characteristics.
- Choice of 12 standard timing characteristics.
- Choice of instantaneous or integrating reset characteristics. Integrating characteristic is in effect when **R** follows one of the curve types — S, L, D, M, I, V, E, A, B, C, G, or F.

Instantaneous Overcurrent (50, 50N)

- Phase settings adjustable over the range of 0.5 to 99 amperes in 0.1 ampere increments and 100 to 150 amperes in 1 ampere increments for a 5 ampere sensing input range and 0.1 to 30 amperes in 0.02 ampere increments for a 1 ampere sensing input range.
- Neutral settings adjustable over the range of 0.5 to 99 amperes in 0.1 ampere increments and 100 to 150 amperes in 1 ampere increments for a 5 ampere sensing input range and 0.1 to 30 amperes in 0.02 ampere increments for a 1 ampere sensing input range.

Fixed Time Overcurrent (50T, 50TN)

- Phase settings adjustable over the range of 0.5 to 99 amperes in 0.1 ampere increments and 100 to 150 amperes in 1 ampere increments for a 5 ampere sensing input range and 0.1 to 30 amperes in 0.02 ampere increments for a 1 ampere sensing input range.
- Neutral settings adjustable over the range of 0.5 to 99 amperes in 0.1 ampere increments and 100 to 150 amperes in 1 ampere increments for a 5 ampere sensing input range and 0.1 to 30 amperes in 0.02 ampere increments for a 1 ampere sensing input range.
- Time delay adjustable over the range of 0.03 to 5.00 seconds for both the 50T and 50TN.

FREQUENCY TRIPPING AND RESTORATION

Underfrequency tripping function provides feeder tripping if the monitored system frequency remains below the user defined 81T trip setting for a period of time 81 TTD (also defined by the user during the setting procedure). This function also can restore the circuit (close the breaker) when the system frequency has returned to normal and stabilized for the duration of 81 RTD (a second user defined frequency and time period). The restore function may be inhibited with one of the user programmable inputs if selected from the PROGRAMMABLE INPUTS screen under REVIEW/EDIT SETTINGS menu as described in publication 9 2315 00 991, *Terminal Displays and Settings*. Operation of this function is inhibited if the monitored system voltage is less than a user defined level, 81 UV INH.

UNDERVOLTAGE TRIPPING

Undervoltage tripping function provides tripping of the feeder if the monitored voltage of any one phase (A, B, and C) voltage remains below the user defined 27 pickup trip setting for a period 27TD (also defined by the user during the setting procedure). The 27 trip function is instantaneously reset when all phase voltages are above the 27 pickup setting. A minimum voltage level of ten volts prevents tripping for blown potential transformer fuses. The undervoltage function is inhibited if the sensing voltage is less than 10.0 volts. A 27TD setting of 0.0 inhibits the 27 function.

OVERVOLTAGE TRIPPING

Overvoltage tripping function provides tripping of the feeder if the monitored voltage of any one phase (A, B, and C) voltage remains above the user defined 59 pickup trip setting for a period 59TD (also defined by the user during the setting procedure). The 59 trip function is instantaneously reset when all phase voltages are below the 59 pickup setting. A 59TD setting of 0.0 inhibits the 59 function.

TRIPPING LOGIC

All protective functions (51P, 51N, 50P, 50N, 50TP, 50TN, 81, 59, and 27) can be configured internally to trip the breaker. The block tripping function is configured to provide selective blocking of tripping at user defined points in the fault clearing sequence by the following:

- Either or all of the phase instantaneous overcurrent elements
- Neutral instantaneous overcurrent element
- Under/Overvoltage function (27/59)
- Underfrequency function (81)

This determination is made during the setting process for the relay from the communication port using the TRIPPING LOGIC screens under the REVIEW/EDIT SETTINGS menu as described in publication 9 2315 00 991, *Terminal Displays and Settings*.

Selected elements can be blocked from tripping by two contact inputs from the SCADA system.

Block trip contact (BT1) blocks tripping by the neutral instantaneous, neutral fixed time, and neutral time overcurrent elements (50N, 50TN, and 51N).

Block trip contact (BT2) blocks tripping by all of the fixed time overcurrent elements (50TA, 50TB, 50TC, and 50TN).

A **PROGRAMMABLE TRIP** (TRIP3) output contact is provided that allows the user to separate selected tripping functions from the main tripping contacts. Such functions include the timed and instantaneous overcurrent elements, underfrequency trip signal, and undervoltage trip signal. These settings are made during the setting process for the relay from the communication port using the PROGRAMMABLE TRIP OUTPUT screen under REVIEW/EDIT SETTINGS menu as described in publication 9 2315 00 991, *Terminal Displays and Settings*.

A **BREAKER FAILURE INITIATE OUTPUT** contact (labeled BFI on front panel output test points and rear panel output contacts) will close for a minimum of 200 milliseconds after the initiation of a TRIP1 command by one of the protective functions (51P, 51N, 50P, 50N, 50TP, 50TN, 81, 59, or 27) or the supervisory trip input if the breaker failure time delay (BF TD) expires and the sensed current is greater than 0.5 amperes (5 ampere CT sensing input) or 0.1 ampere (1 ampere CT sensing input). The range of the breaker failure time delay is 0.03 to 0.50 seconds.

NOTE

The BFI output will NOT occur if the trip command is only through the TRIP2 output.

BE1-DFPR Functional Description

The TRIP 1 output remains closed for a minimum of 200 milliseconds after initiation of a trip command. Only TRIP 1 can initiate a breaker failure sequence. Refer to Figure 3-3 for a typical breaker failure sequence with BF TD = 0.18 seconds.

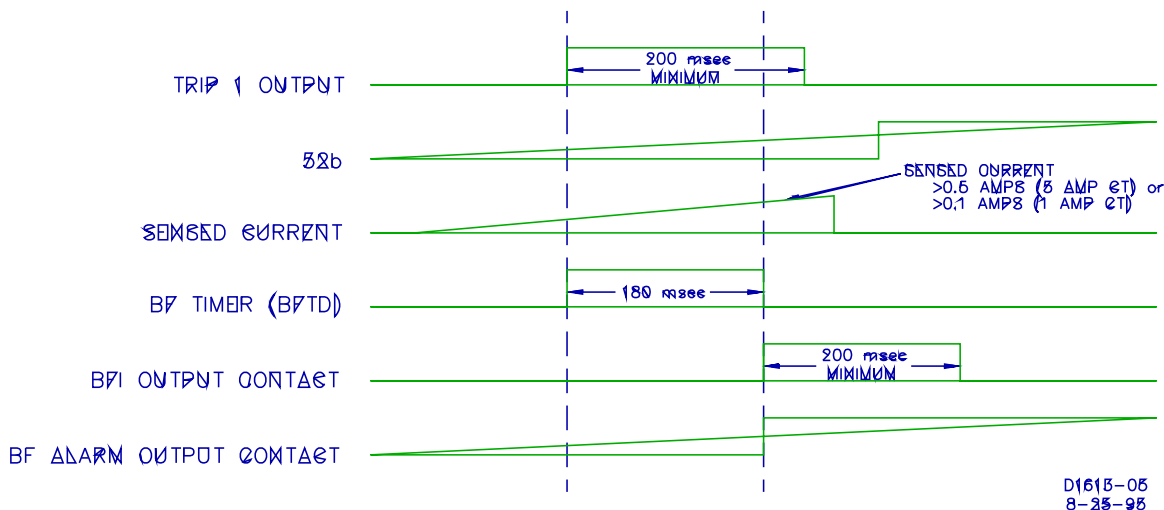

Figure 3-3. Typical Breaker Failure Sequence

AUTOMATIC RECLOSING

BE1-DFPR relays include a reclosing section that provides up to 4 reclosing attempts. CLOSE 1 and CLOSE 2 outputs operate in parallel and remain closed for a minimum of 200 milliseconds upon receipt of a CLOSE command. The time ranges are as follows:

Reclosing delays:

- 1st shot - 0.04 to 100 seconds
- 2nd shot - 0.04 to 200 seconds
- 3rd shot - 1.0 to 200 seconds
- 4th shot - 1.0 to 200 seconds

The number of reclosing attempts may be limited by setting any of the reclose time delays to zero. A reclosing attempt time delay set to zero forces the reclose logic to LOCKOUT and will not allow any further reclosing attempts.

A **MAXIMUM CYCLE TIMER** is included to limit the total fault clearing and restoration sequence to a definable period. This timer is started at the time the first trip command is output from the protective section of the relay and is stopped when the reclosing function is reset. This timer has a range of 0 to 999 seconds. If this programmed time expires, the reclosing function will go to the LOCKOUT state. This timer may be disabled during the setting procedure if not desired by setting it to zero.

FAILURE TO RECLOSE timer is included to limit the duration of the closing signal to the breaker. This timer has a range of 0 to 9.9 seconds. This timer may be disabled during the setting procedure if not desired by setting it to zero. If this programmed time expires, the reclosing function will go to the LOCKOUT state.

RESET timer is included to allow a stabilizing period after a reclose has occurred before the beginning of another reclose sequence is initiated. This timer has a range of 1 to 200 seconds.

ZONE SEQUENCE COORDINATION

In order to coordinate the tripping and reclosing sequence with downstream protective relays and reclosers, the DFPR senses fault current from downstream faults with the low set (50TP and 50TN) instantaneous elements. If the upstream relay (DFPR) senses that fault current has been interrupted by a downstream device, the DFPR will increment the trip/reclose sequence by one shot. This happens because the DFPR recognizes that a non-blocked low set (50TP or 50TN) element picked-up and reset before timing out to trip.

BE1-DFPR Functional Description

A zone sequence event is logged at the time the 50TP or 50TN element resets (before timing out to trip).

Zone sequence coordination can be disabled by programming one of the user programmable inputs (USR1, USR2, USR3, USR4, or USR5).

These parameters may be set during the setting process for the relay from the communication port using the PROGRAMMABLE INPUTS screen under REVIEW/EDIT SETTINGS menu as described in publication 9 2315 00 991, *Terminal Displays and Settings*.

CONTACT SENSING INPUTS

Contact sensing inputs to the relay are provided for the following functions.

Reclose Initiate (RI)

RI initiates or blocks the reclosing function for an external protective trip. When closed, this contact would allow automatic reclosing by the relay for a protective trip. When open, a breaker opening would not result in automatic reclosing unless the reason for tripping was initiated by the selected protective functions within the relay. Recognition dropout time for RI with an external protective trip is 225 milliseconds. A reclosing sequence starts if a 52b input occurs within 225 milliseconds after the RI input or if the 52b occurs while RI is present. Figure 3-4 illustrates the recognition dropout timing relationship.

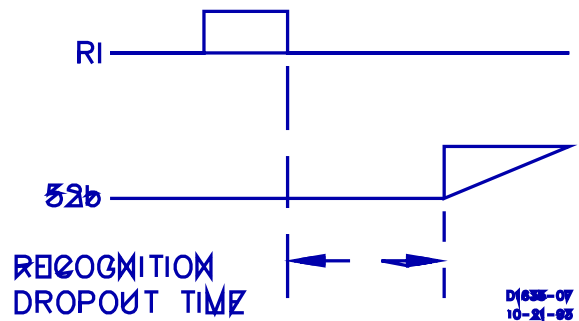

Figure 3-4. Recognition Dropout Timing

Reclose Disable (RDS)

A momentary closure of this contact will cause the reclosing function to assume a disabled state. The timing of the reclosing function will be disabled but not reset in this condition. The relay will remain in this condition until a closure of the **ENABLE** contact (REN) is recognized. The front panel INH LED will be on for this condition.

Reclose Enable (REN)

A momentary closure of this contact will cause the reclosing function to resume its operation from the point of interruption caused by the DISABLE contact (RDS) closure. If the breaker is closed the relay shall return to the RESET state. The front panel INH LED will be off for this condition.

Drive To Lockout (DTL)

Puts the reclosing function into the LOCKOUT condition. This condition will persist for the period defined by RESET time after the DTL contact is opened and the breaker is determined to be closed.

RECLOSE LOGIC

All protective functions (51P, 51N, 50P, 50N, 50TP, 50TN, 59, and 27) except the 81 protective function may be configured internally to initiate reclosing the breaker. The 81 protective function has a dedicated restore time delay for reclosing the breaker. Reclosing logic can be configured to block the reclosing initiated by the protective functions (51P, 51N, 50P, 50N, 50TP, 50TN, 59, and 27) and the reclose initiate (RI) contact sensing input. During the setup process, the user may block initiating reclosing at user defined points in the reclosing sequence. Setup is accomplished from the communication port using the RECLOSE LOGIC SCREENS UNDER THE review/edit settings MENU as described in publication 9 2315 00 991, *Terminal Displays and Settings*.

CONTROL FUNCTIONS

Supervisory Trip/Supervisory Close (Trip/Close)

In addition to providing protection for the feeder, the BE1-DFPR is capable of accepting breaker **TRIP** and **CLOSE** commands from momentary contact closures of the SCADA system or breaker control switch and issuing the actual commands to the breaker.

BE1-DFPR Functional Description

Two inputs to the relay are provided for this purpose. The **TRIP** input to the relay will not initiate the reclosing operation, but will put the reclosing section into LOCKOUT. A **CLOSE** input to the relay will initiate only the RESET timer in the reclosing function. This action allows the breaker to be manually closed and trip free without the reclosing function becoming active and pumping the breaker.

Block Load Tap Changer (BLTC)

An output of the relay is available to block the operation of a load tap changer on a substation transformer or voltage regulator during the fault clearing and restoration process. This normally closed contact (BLTC) will be open from the time the relay initiates a protective trip and will remain open until the reclosing function is either reset or locked out.

SYSTEM DIAGNOSTICS AND ALARM OUTPUTS

Relay Trouble

This NC contact will be energized after an initial power-up delay and remain energized (open) unless one of the following problems is detected within the relay:

- Power Supply failure (Relays may be supplied with an optional redundant power supply. Each power supply is capable of supplying the total requirements of the package. Failure of either power supply will result in an alarm.)
- Microprocessor/program problem
- Memory check
- A/D converter monitor
- Communications board failure

Target Alarm Contacts

Seven programmable alarm contacts are provided to define to the SCADA system which elements and which functions (50A, 50B, 50C, 50N, 50TA, 50TB, 50TC, 50TN, 51A, 51B, 51C, 51N, 81, 27, 59, or BF) operated for a fault. These outputs must be reset at the relay front panel using the Status/TARGETS RESET switch.

Breaker Fail Alarm

This contact provides an indication that a problem with the controlled circuit breaker has been detected by one of the monitoring circuits. Circuits are included to monitor:

- Breaker trip coil for continuity
- Breaker position. The position of the breaker is determined by monitoring both an a and b contact. These must agree on the position of the breaker.
- Breaker close time. The breaker must close within the period of the RECLOSE FAIL timer.
- Breaker did not open. The breaker did not open within the breaker fail time delay (BF TD).

Lockout Alarm

This contact will close when the reclosing section of the relay is in the LOCKOUT condition. In addition to signifying that the reclosing sequence was unsuccessful, this contact will be closed following a supervisory trip of the breaker, or when the DRIVE TO LOCKOUT input contact has been closed. This contact will also close when the maximum number of breaker operations has occurred or the maximum breaker duty has been reached.

Programmable Alarms

Two contacts are provided that allow the user to define the conditions for their closure. These contacts can be programmed to signify any of the following conditions.

- That breaker duty is near the limit
- Maximum breaker operations is near the limit
- A failure to reclose occurred

BE1-DFPR Functional Description

- Open trip coil or trip circuit exists
- A slow breaker trip occurred
- Indeterminate breaker position occurred
- A single power supply failed
- RS-232-C communication failed

These settings are made and the status of all the alarms is shown during the setting process for the relay from the communication port using the PROGRAMMABLE ALARMS screen under the REVIEW/EDIT SETTINGS menu as described in publication 9 2315 00 991, *Terminal Displays and Settings*.

INSTRUMENTATION

The relay will monitor, calculate and record the following power system parameters for later retrieval through the communications interface or the front panel display:

Real Time Values

- Phase amps (A, B, C, and N)
- Neutral amps
- Phase voltage
- System frequency
- Power levels of watts (current, times voltage, times cosine of theta), vars (current, times voltage, times sine of theta), and VA (current, times voltage)
- Power factor

Demand Values

- Phase amps (A, B, C, and N)
- Watts
- VARS
- VA

Sensed currents will be displayed over the range of 0.0 to 7.5 amperes. Voltage will be displayed over the range of 0 to 130 volts.

Demand values may be calculated over an interval defined by the user from 1 to 60 minutes.

Status Conditions

- Contact sense input status
- Active settings mode (Normal, Aux 1, Aux 2, Aux 3, or Aux 4)
- Test mode, front panel settings access
- Protective element pickup status and target status

Data Collection and Storage

BE1-DFPR relays collect and store data in memory for interrupted current values, demand values, and breaker operations. The stored values are:

- Energy accumulation in the form of watt hours, var hours and number of hours since last reset
- Interrupted current cumulative, last, and maximum values
- Demand current maximum and minimum values
- Demand watts, vars, VA, maximum, and minimum values
- Total number of breaker operations (trip)

Stored data is a valuable tool that can be used to determine maintenance requirements for protected breakers. To select data for collection and storage and retrieve the stored data, use the REVIEW/RESET MAINTENANCE VALUES screen as described in the settings procedures in publication 9 2315 00 991,

BE1-DFPR Functional Description

Terminal Displays and Settings.

Fault Data

The relay logs and records the 40 most recent breaker operations or trigger events (trip and close are 2 separate events). Each event record contains the following information.

- Breaker limit status (breaker failure or maximum breaker operation)
- Time and date (10 millisecond resolution)
- Type of event (trip, close, external trigger, or zone sequence)
- Reclose status
- Operational setting (Normal, Aux 1, Aux 2, Aux 3, or Aux 4)
- Programmable alarm status

For tripping events only, the relay also records:

- Breaker interruption time (time from initiation of trip output to interruption of current)
- All Target data (functions and elements)
- Interrupted Current magnitude (real time value)
- Voltage magnitude (real time value)

For trigger events or zone sequence events, the relay also records:

- All target data (functions and elements)
- Current magnitude (real time value)
- Voltage magnitude (real time value)

The trigger event is enabled by closing one of the user programmable inputs if selected from the PROGRAMMABLE INPUTS screens under the REVIEW/EDIT SETTINGS MENU as described in publication 9 2315 00 991, *Terminal Displays and Settings*.

Recorded fault data is available through the communication ports and is compatible with readily available communication software packages that emulate dumb terminal modes. For explanation of the format, refer to the REVIEW EVENT screen as described in publication 9 2315 00 991, *Terminal Displays and Settings*.

COMMUNICATIONS

General

Communications interface is provided on the relay front and rear panels. The front panel interface is compatible with standard RS-232 connectors and software. The rear panel interface is compatible with either standard RS-232 or RS-485 connections. Communications protocol is compatible with readily available modem software that emulate a dumb terminal. RS-485 communication is optional and supports special application protocols.

Access to the relay functions and data is limited by a built in multi-level security system of user assigned passwords. This scheme is intended to prevent unauthorized access or configuration changes to the settings and data contained within the relay.

Through passwords, the users authorized personnel may:

- Define the settings of the overcurrent elements, and reclosing functions
- Define auxiliary settings, (auxiliary 1 (CLP), auxiliary 2 (EP), auxiliary 3, and auxiliary 4)
- Define tripping logic and reclosing logic for fault clearing and reclosing sequence
- Determine the relay status
- Determine the breaker position
- Read and reset the fault data log for the most recent 40 events
- Read all power system operational parameters or select specific measured and calculated real time values to be displayed on the relay front panel display
- Read all power system demand values or select specific demand values to be displayed on the relay front panel display
- Determine the number of operations and total interrupted current since the last maintenance cycle
- Reset the numbered of breaker operations stored
- Upload settings

BE1-DFPR Functional Description

RS 232-C Format

The following parameters or settings should be set in the external terminal or computer configuration.

- Baud rate 300, 600, 1200, 2400, 4800, 9600, or 19200
- Data bits Eight
- Stop bits Two
- Parity None
- Terminal emulation DEC VT-100 compatible
- Software flow control (XON, XOFF) ON
- Carriage return (CR) translation . . . Carriage return only.
- Line feed (LF) OFF
- Line wrap OFF

Serial Port Connections and Configurations

Front and rear serial communication ports are RS 232-C female DB-9 connectors used to communicate with data terminal equipment (i.e. - computer or terminal) or data communications equipment (i.e. - modem). Because communication intelligence resides inside the relay, no special commands or software is needed to retrieve and transmit data other than a few keystrokes from the external terminal or computer. Off-the-shelf modem software such as *Procomm V2.4* can be used to communicate with the relay.

Computers with Windows can use Windows Terminal application to communicate with the relay. To setup the Terminal application, choose terminal in the accessories group. Pull down the Settings menu and select Terminal Emulation (refer to Figure 3-5). After you have chosen Terminal Emulation, a dialog box similar to Figure 3-6 should appear. Select DEC VT-100 and OK the selection.

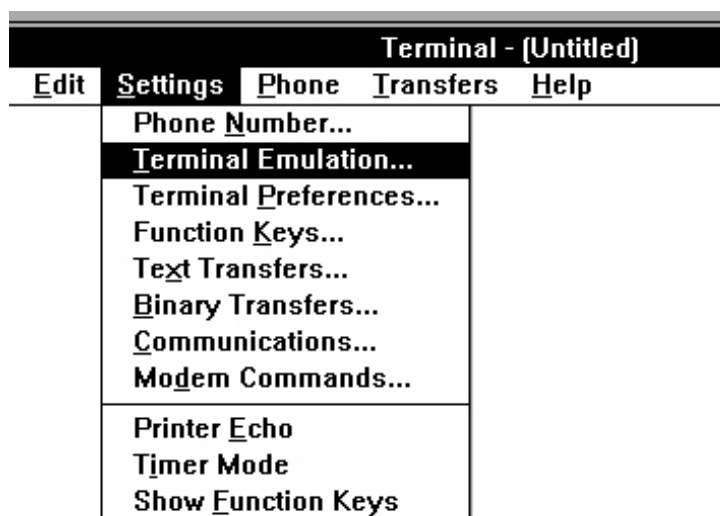

Figure 3-5. Settings Menu

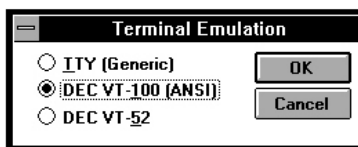

Figure 3-6. Terminal Emulation

Pull down the Settings menu again, select Terminal Preferences, and a dialog box similar to Figure 3-7 should appear. Choose settings as shown.

BE1-DFPR Functional Description

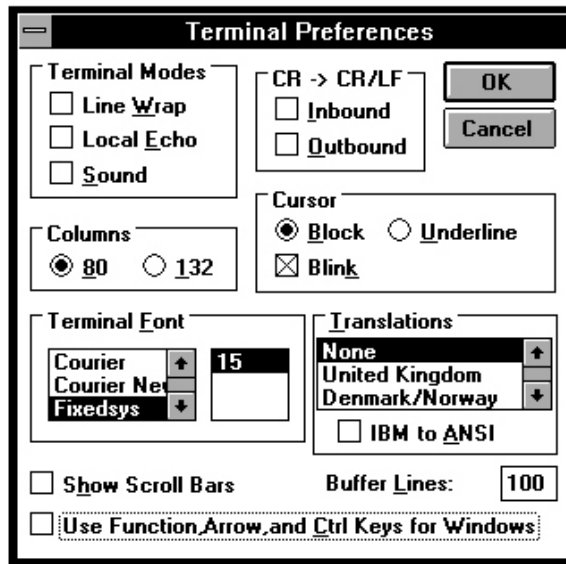

Figure 3-7. Terminal Preferences

Next specify the communications settings. From the Settings menu, choose Communications and a dialog box similar to Figure 3-8 should appear. Choose settings as shown.

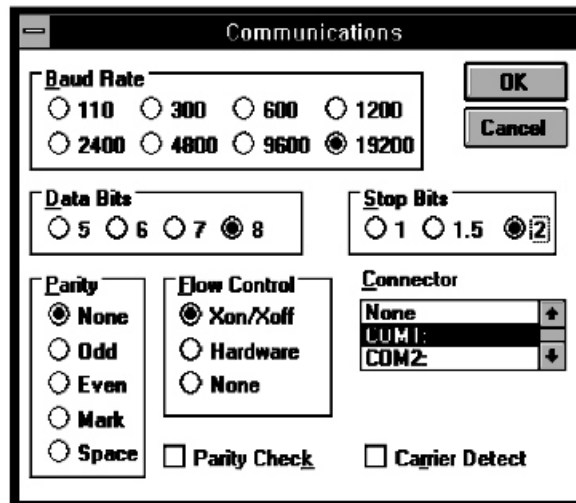

Figure 3-8. Communications Settings

To initially prepare the relay for communications, set the front panel baud rate using front panel switches in the settings mode. The K-BAUD setting must be selected by using the settings select switch. Once the K-BAUD setting is selected, the desired baud rate is set using the settings raise/lower switch. The rear port baud rate can only be set from the installation settings screen under the REVIEW/EDIT Settings menus as described in publication 9231500991, *Terminal Displays and Settings* using an external terminal or computer. The same baud rate selected for the relay must also be selected on the external terminal or computer.

Serial Communication

Front and rear serial port communication cannot take place at the same time. Priority is given to the front panel port.

If communication is in progress but no keys on the terminal are typed for five minutes, communication is stopped. A fixed timeout of five minutes in the relay software allows switching devices such as the SEL PRTU or RFL 9660 switch to regain communication at the rear port in case the front port is left unattended or connected.

BE1-DFPR Functional Description

If rear port communication is taking place when the front port is connected, rear port communication must be stopped before front port communication can begin. Two methods are available to stop rear port communication. They are:

- Keystroke ESC (to enter the main menu) must be typed on the front (local) terminal/computer.
- Keystroke Q (to exit the main menu) must be typed on the rear (remote) terminal/computer.

An XON (Ctrl-Q) may be needed at the front port to start communications if the rear port had recently received an XOFF (Ctrl-S). To allow rear port communication to continue, the front port must exit from the main menu with the Q keystroke or allow the five minute timeout to stop communication.

Use built-in functions in the modem software to print screen data or capture data to a file. No special commands are needed to retrieve data other than a few keystrokes to select the desired screen. Each screen is displayed by transmitting a series of information strings. The information can be raw data, such as the text that comprise column titles or escape sequences that are interpreted by the VT-100 compatible terminal to perform various functions such as clearing the screen, positioning the cursor, set screen attributes, etc. Lines on a screen can be displayed in any order. In fact, screen information is displayed in a totally random fashion (bottom lines can be transmitted prior to top lines, right most data can be displayed prior to left most data). XON (Ctrl-Q) and XOFF (Ctrl-S) can freeze data on the remote terminal or computer screen as the screen is being updated.

Starting Communication

With a computer or terminal connected to the relay and the modem software operating, begin communication by pressing the ESC key (refer to Figure 1-1 for screen flow diagram and keystroke sequence). Screen 1, MAIN MENU, appears on the monitor when communication begins. From this point on, the communication is menu driven. Select the desired main activity (screen number) to continue or Q to exit. Movement is made within the screens with standard arrow keys → ← ↑ ↓. To refresh the screen with the latest data, use **Ctrl-R**. For full details of all other screens refer to publication 9 2315 00 991, *Terminal Displays and Settings*.

Downloading And Uploading Settings

All of the settings stored in a relay (except for passwords) may be retrieved through communication ports. Once they are received, the settings may then be uploaded to another relay or printed. For downloading or uploading settings, you must start communication as described in the previous paragraph to get the MAIN MENU on the screen and then follow the procedure described in *Downloading Settings* or *Uploading Settings*.

CAUTION

This product contains one or more nonvolatile memory devices. Nonvolatile memory is used to store information (such as settings) that needs to be preserved when the product is power-cycled or otherwise restarted. Established nonvolatile memory technologies have a physical limit on the number of times they can be erased and written. In this product, the limit is 100,000 erase/write cycles. During product application, consideration should be given to communications, logic, and other factors that may cause frequent/repeated writes of settings or other information that is retained by the product. Applications that result in such frequent/repeated writes may reduce the useable product life and result in loss of information and/or product inoperability.

Downloading Settings

After the MAIN MENU is selected, type **Q** to exit the screen. This prepares the relay to receive the next communication command.

- Select download file:

Procomm V2.4 — Select download with the page down key and **ASCII** format (protocol)..

Windows 3.1 — Under the program group **Accessories**, select **Terminal**. Under the **Terminal**, **Settings** menu select **Text Transfers** and the parameters as shown in Figure 3-9. Then from the **Transfers** menu, select **Receive Text File** as shown in Figure 3-10 and the parameters as shown in Figure 3-11.

BE1-DFPR Functional Description

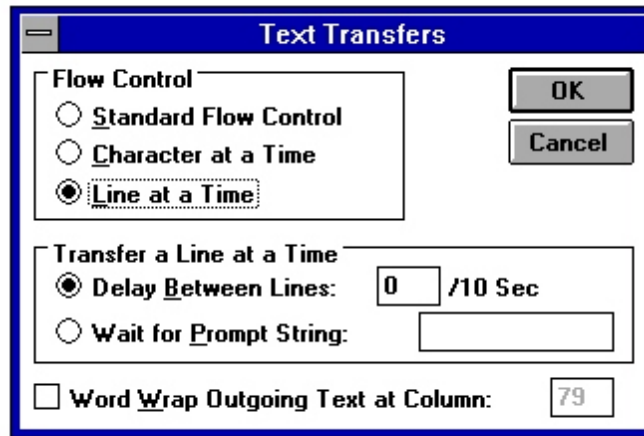

Figure 3-9. Text Transfers Settings

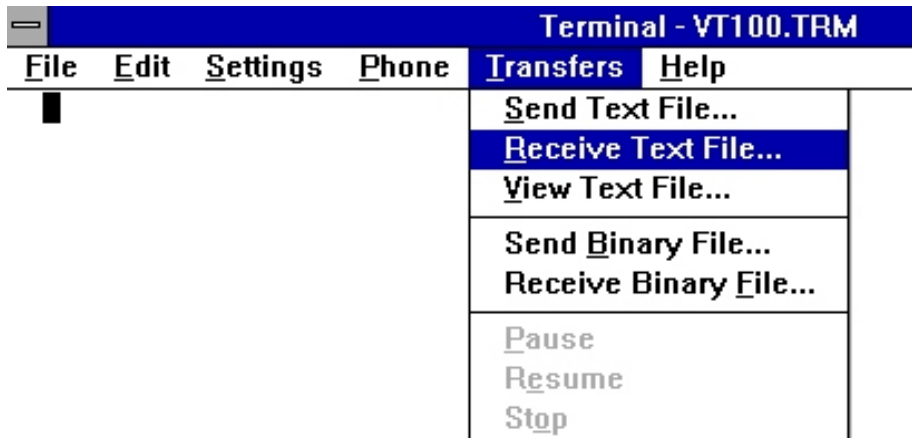

Figure 3-10. Transfers Menu

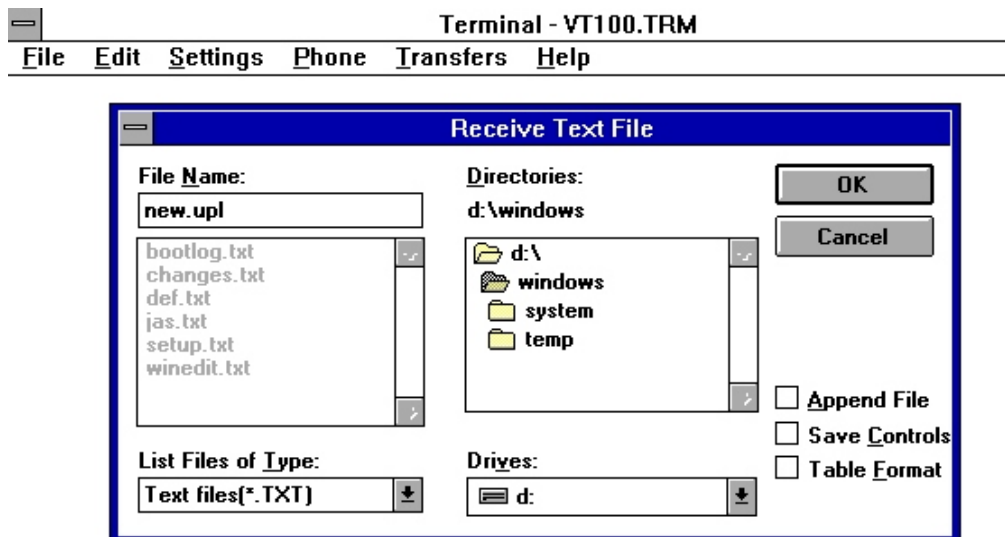

Figure 3-11 Receive Text File Settings

BE1-DFPR Functional Description

- Name the file: *Procomm V2.4* — Type the file name.
Windows — Type the file name.
- Save the file: *Procomm V2.4* — After typing the name of the file, execute **Cntl-O**. The screen will echo data sent from the relay to the computer.
Windows — Select **OK**. Execute **Cntl-O** and the screen will echo some of the data sent from the relay to the computer.
- Close the file: *Procomm V2.4* — Press **ESC**. Press **ESC** a second time to return to the MAIN MENU screen.
Windows — Select **STOP** at the bottom of the screen. Press **ESC** to return to the MAIN MENU screen.

Uploading Settings

After the MAIN MENU is displayed, select **4** for REVIEW/EDIT SETTINGS. Enter the correct password and the REVIEW/EDIT SETTINGS screen is displayed. Type **F** to select the UPLOAD SETTINGS screen and the middle of the screen displays **READY TO RECEIVE SETTINGS**.

- Upload file: *Procomm V2.4* — Select upload with the page up key and **ASCII** format (protocol).
Windows 3.1 — Under the program group **Accessories**, select **Terminal**. Under the **Terminal**, **Settings** menu select **Text Transfers** and the parameters as shown in Figure 3-9. Then from the **Transfers** menu, select **Send Text File** and the parameters as shown in Figure 3-12.

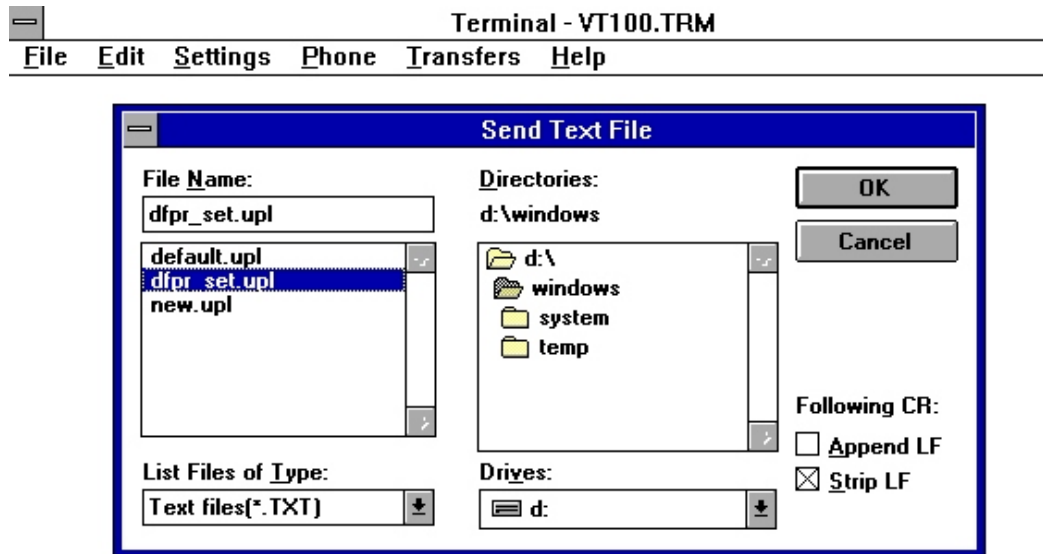

Figure 3-12. Send Text File Settings

BE1-DFPR Functional Description

- Name the file: *Procomm V2.4* — Type the file name.
Windows — Type the file name.
- Load the file: *Procomm V2.4* — After typing the name of the file, execute **Enter**. If the data is received without an error, the middle of the screen displays **SETTINGS ACCEPTED** and the relay front panel display shows **dumpset rcvd**. If an error does occur, i.e. CRC error, **CRC ERROR** is displayed in the middle of the screen.
Windows — Select **OK**. If the data is received without an error, the middle of the screen displays **SETTINGS ACCEPTED** and the relay front panel display shows **dumpset rcvd**. If an error does occur, i.e. CRC error, **CRC ERROR** is displayed in the middle of the screen.
- Close the file: *Procomm V2.4* — Press **ESC**. Press **ESC** a second time to return to the MAIN MENU screen.
Windows — Press **ESC** to return to the MAIN MENU screen.

Capturing Data To A File

When you have completed a communications procedure, you may want a printed or file copy for later reference. You can use the following procedures to capture computer communications screen data when you are using either Windows™ or Procomm®.

Windows

A screen display may be copied to the clipboard by two different methods. One — as text; or two — as a graphic. Once the data is copied to the clipboard, it can be pasted into any Windows™ based application.

- Text Method — Select the desired screen that you want to copy. Type **CNTL-S** (XOFF) to stop screen updating. Pull down the **Terminal, EDIT** menu and click on **Select All**. As a result, the entire screen should be highlighted. Again, pull down the **Terminal, EDIT** menu and this time click on **Copy**. This copies the screen data to the clipboard. Type **CNTL-Q** (XON) to allow screen updating.
- Graphic Method — Select the desired screen that you want to copy. Type **ALT +Print Screen**. As a result, the screen data is copied to the clipboard.

Procomm

Select the desired screen that you want to copy. Type **ALT +G**. As a result, the screen data is copied to a file **procomm.img**. Any additional screens that you copy are appended to the file **procomm.img**.

SECTION 4

INSTALLATION

GENERAL

When not shipped as part of a control or switchgear panel, BE1-DFPR relays are shipped in a sturdy carton to prevent damage during transit. Immediately upon receipt, check the model and style number against the requisition and packing list to see that they agree. Visually inspect for damage that may have occurred during shipment. If there is evident damage, immediately file a claim with the carrier and contact a sales representative at Basler Electric, Highland, Illinois.

In the event the unit is not to be installed immediately, store it in its original shipping carton in a moisture and dust free environment. It is strongly recommended that an operational test (refer to Section 5) always be performed prior to installation.

OPERATING PRECAUTIONS

Before installation or operation, observe the following precautions.

1. Always be sure that external operating (monitored) conditions are stable before removing a BE1-DFPR unit for inspection, testing, or servicing.
2. BE1-DFPR relays are solid-state devices and have been type tested in accordance with the requirements defined in the following paragraph, Dielectric Test. If a wiring insulation test is required on your switchgear or panel assembly and this relay is to be tested, observe the information noted in the following paragraph, Dielectric Test.
3. Be sure that the BE1-DFPR chassis is hard wired to earth ground using the chassis ground (terminal 25) on the rear of the unit.
4. When the unit is in service, the controls should be protected by the cover supplied. This limits access to the control settings.

DIELECTRIC TEST

BE1-DFPR relays have been type tested in accordance with the requirements of IEC 255-5 and ANSI/IEEE C37.90.1-1989. One-minute dielectric (high potential) tests of the assembled switchgear or control panel wiring may be performed using up to 1500 Vac (45-65 Hz). Note that decoupling capacitors (0.01 microfarad) are employed from all terminals to surge ground. Accordingly, a leakage current of approximately 5.6 milliamperes per terminal is to be expected when high potting at 1500 Vac, 60 hertz.

MOUNTING

BE1-DFPR relays are designed to be rack-mounted. Overall dimensions are shown in Figure 4-1. BE1-DFPR relays may also be panel mounted. Use the cutout dimensions of Figure 4-2 as a guide. Relays may be mounted at any convenient angle. Horizontal and vertical mount relays have the same overall and cutout dimensions. Metric dimensions are shown in parentheses.

BE1-DFPR Installation

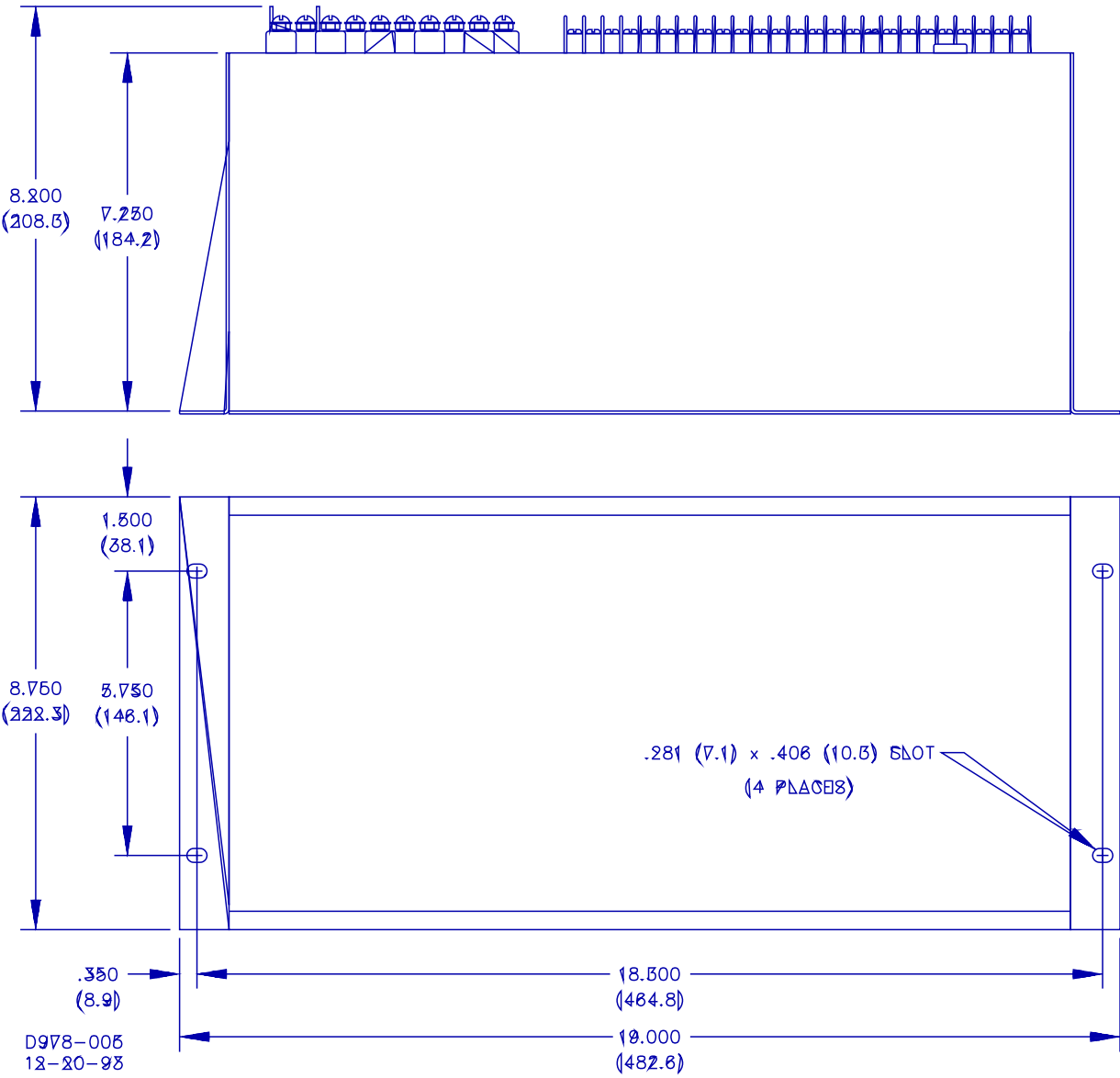

Figure 4-1. Outline Dimensions (Rack Mounting)

BE1-DFPR Installation

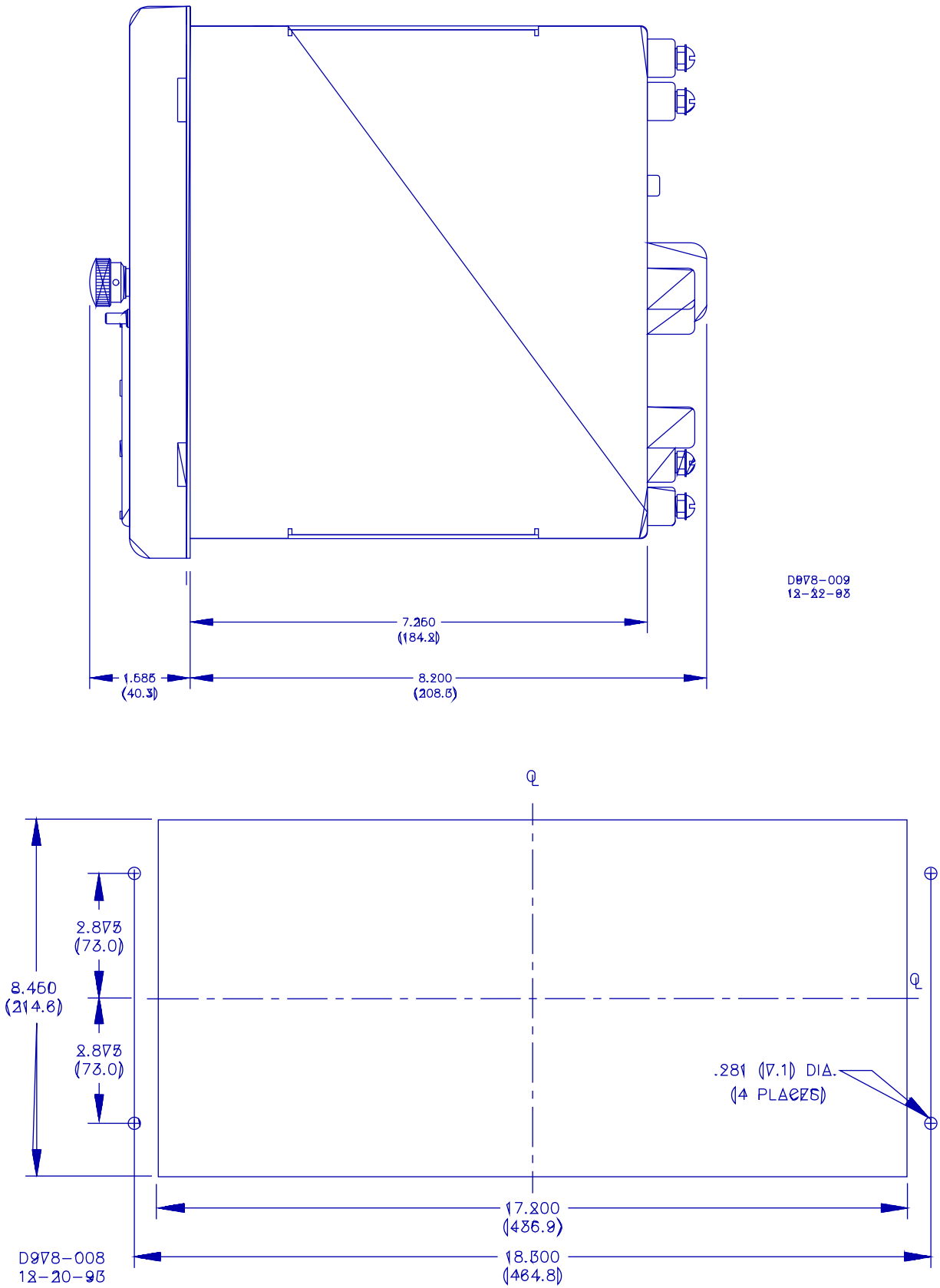

Figure 4-2. Outline Dimensions (Panel Mounting)

BE1-DFPR Installation

CONNECTIONS

Typical DC control connections are shown in Figure 4-3. A typical Connection Diagram is shown in Figure 4-4. BE1-DFPR relay terminals as seen from the back of the relay are identified in Figure 4-5. All terminals are suitable for use with wire sizes of 12 AWG or smaller. Terminal strips mounted on the rear of the relay have 6-32 screws that accept wire sizes of 12 AWG and smaller or 0.312 inch wide rings and spade terminals. It is important to provide a ground connection for chassis ground (terminal 25). Incorrect wiring may result in damage to the unit.

Communication connections are shown in Figures 4-6 through 4-9.

On units with the test module option, current and voltage inputs and control outputs can be tested by removing the connection plugs and replacing them with test plugs (Basler part number 10095 or G.E. model XLA12A). Doing this disconnects these inputs and outputs from the relay internal circuits. With the test plugs installed, test inputs can be injected, and the relay trip and close outputs can be monitored.

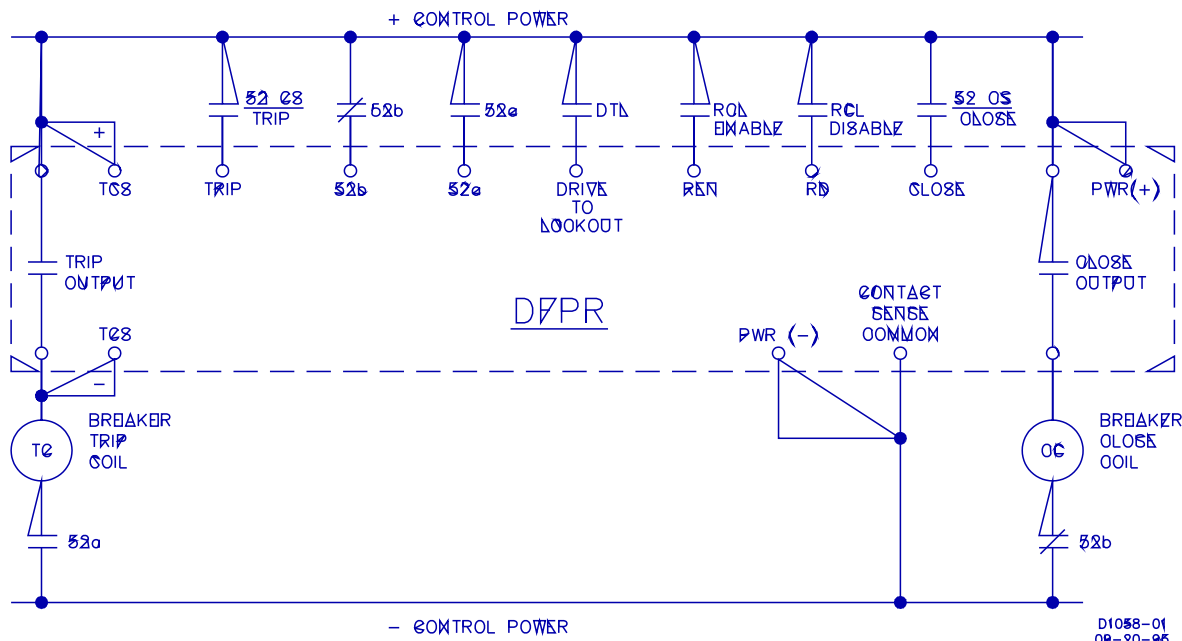

Figure 4-3. DC Control Connections (Typical)

BE1-DFPR Installation

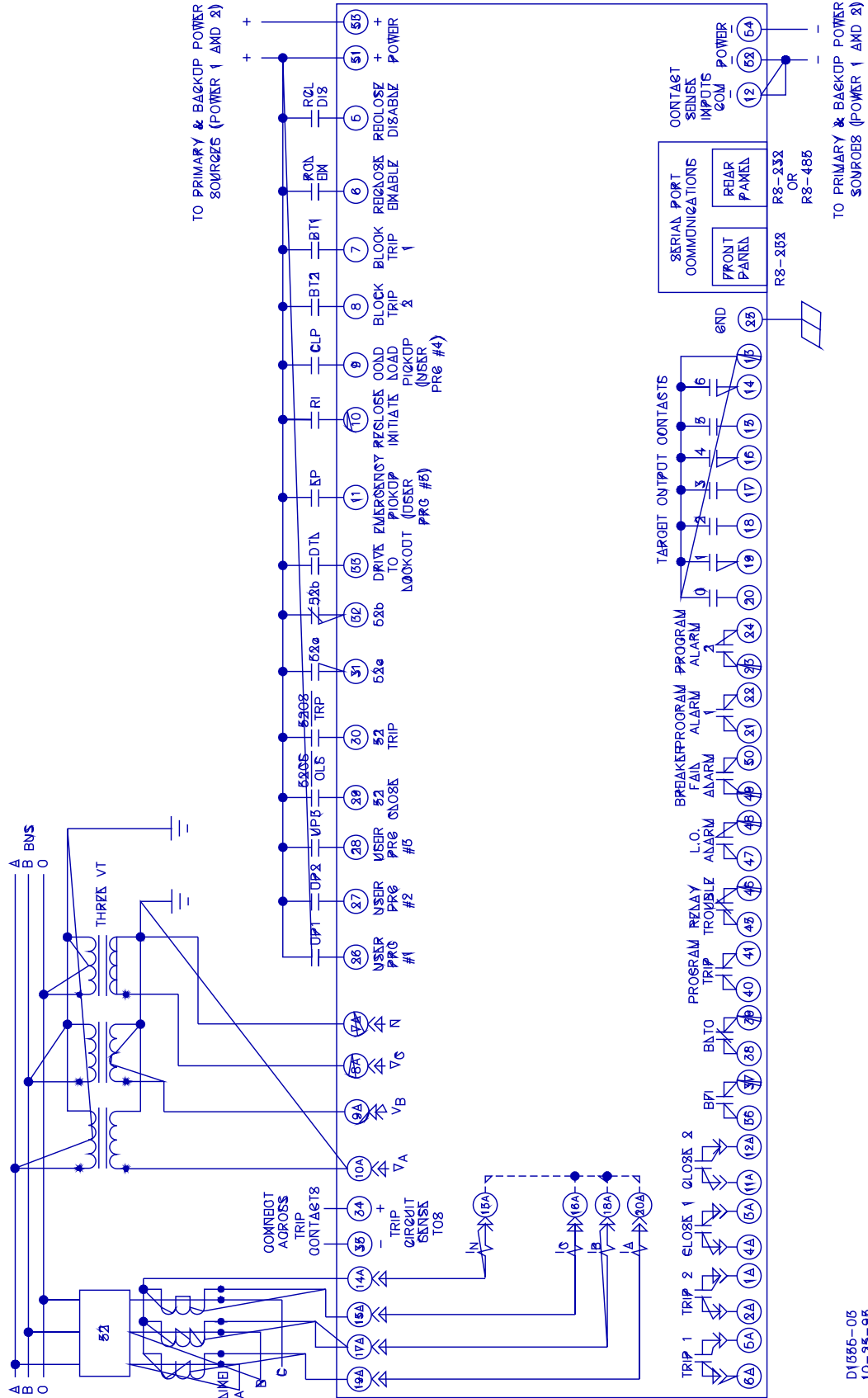
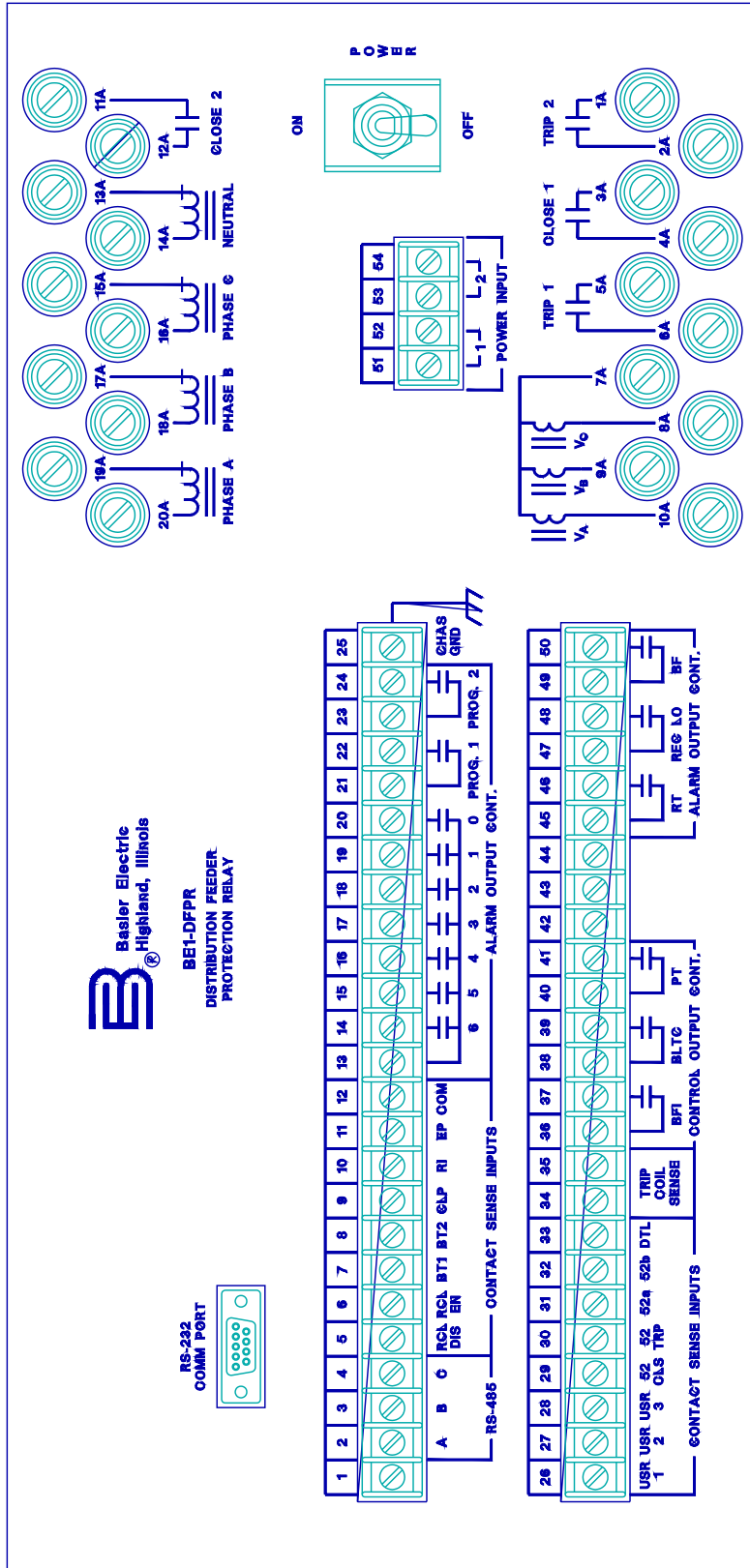

Figure 4-4. Connection Diagram

BE1-DFPR Installation



DB05-008
3-10-84

Figure 4-5. BE1-DFPR Rear View

BE1-DFPR Installation

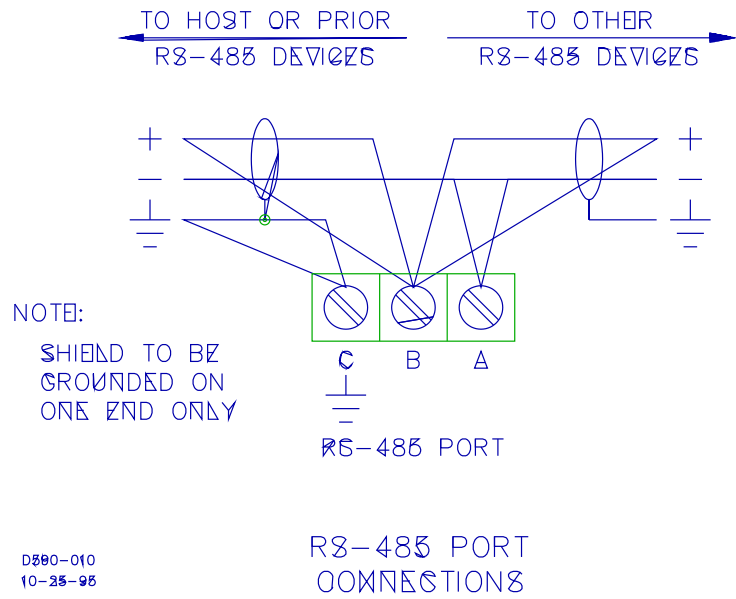
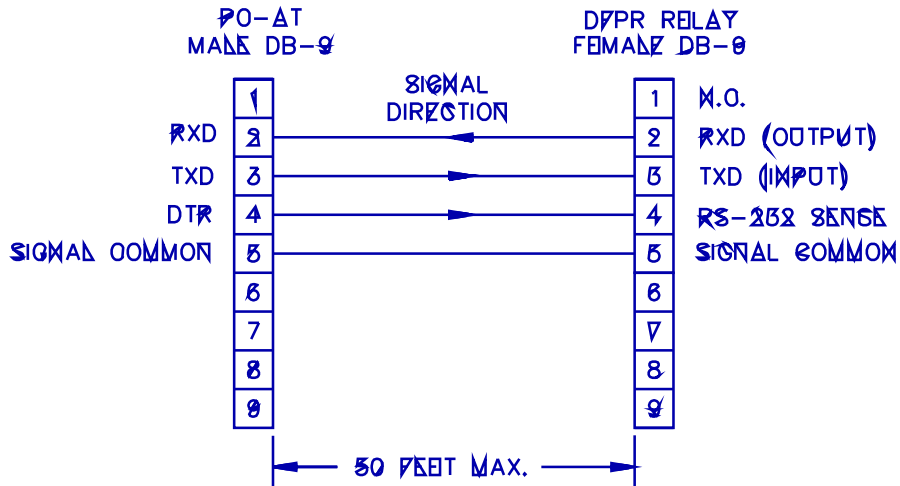
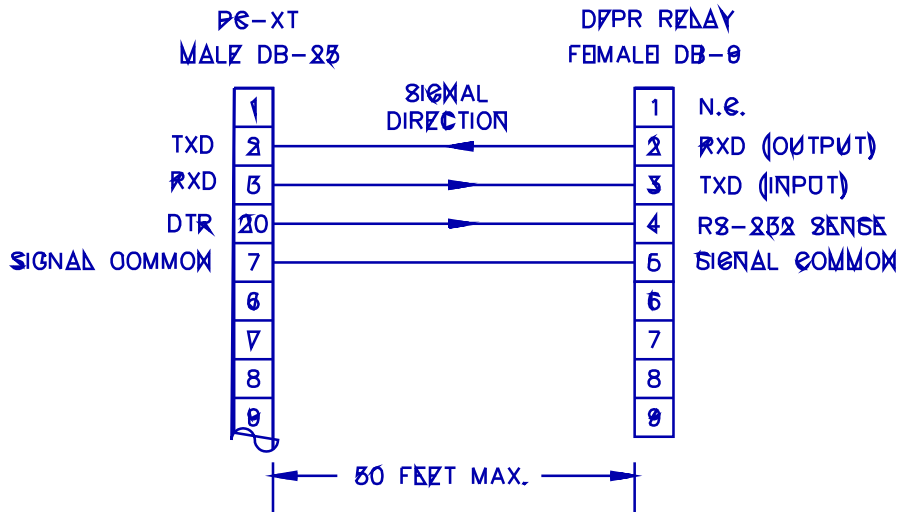

Figure 4-6. Communications Interface

BE1-DFPR Installation



PC-AT TO DFPR RELAY



PC-XT TO DFPR RELAY

D1815-06
2-9-84

Figure 4-7. RS-232 Connection Diagram For IBM Type Computers

BE1-DFPR Installation

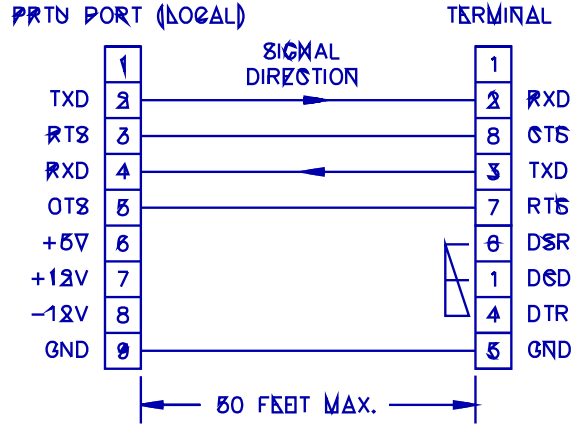

PROTECTIVE RELAY TERMINAL UNIT (PRTU) TO DATA TERMINAL EQUIPMENT (DTE)

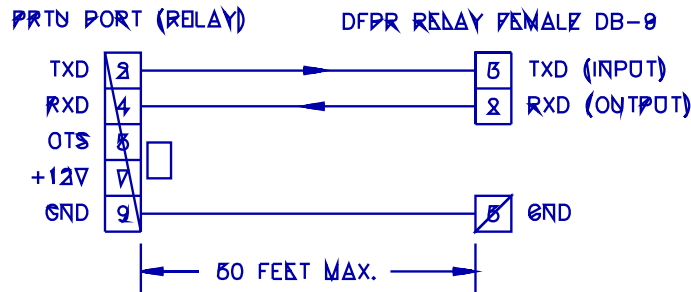

PROTECTIVE RELAY TERMINAL UNIT (PRTU) TO DFPR RELAY

D1615-07
2-9-84

Figure 4-8. RS-232 Connection Diagram for Protective Relay Terminals

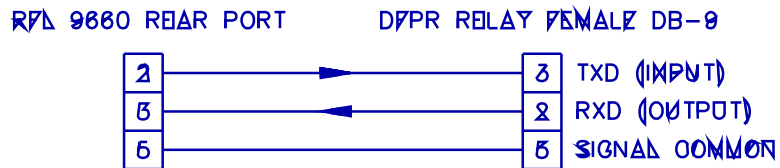

RFL 9660 PROTECTIVE RELAY SWITCH TO RELAY

D1615-08
2-9-84

Figure 4-9. RS-232 Interconnection Diagram For RFL 9660 Switch

SECTION 5

TESTING

GENERAL

A BE1-DFPR Test Simulator (shown in Figures 5-1 and 5-2) makes testing BE1-DFPR relays much easier. All contact sensing inputs and enable inputs are simulated by toggle switches that are easily accessible on the front panel. Appropriate LEDs provide BE1-DFPR relay functional indications. Additionally, the test procedures in this section use the Test Simulator switch and LED names. A Test Simulator schematic diagram is provided in Figures 5-3 and 5-4.

TESTING

Testing BE1-DFPR relays requires that they be isolated from the controlled system. A bench-test setup that would be appropriate is illustrated in Figure 5-5.

OPERATIONAL TEST PROCEDURE

Preliminary Setup Procedure

- Step 1. Connect the relay to the test set as shown in Figure 5-5.
- Step 2. Position test set POWER switch to ON.
- Step 3. Close the simulated breaker by operating the test set CLOSE switch (the test set 52a LED should illuminate).
- Step 4. Close (UP) the trip coil sense (TCS) switch on the test set and open (DOWN) all other input switches.
- Step 5. Apply nominal power supply voltage to the power input terminals on the relay and the contact sensing input on the test set.

Power and Operate Mode LED's on the relay should be illuminated. If the Test Mode LED is ON, push the Pull Test Push Operate knob in so that the Operate Mode LED is ON.

Entering Time and Date Settings

- Step 1. Perform the Preliminary setup procedure.
- Step 2. Use the Settings Select switch to bring the time and date settings onto the display.
- Step 3. Use the Settings Raise/Yes Lower/No switch to set the current time and date.
- Step 4. Operate (UP) the Status/Targets Select switch to save the current time and date. If the time and date were the only settings change the relay will return to operate mode and save the new time and date.
- Step 5. Verify that the time and date is keep during a loss of power by removing and then applying the input power.
- Step 6. Operate the Status/Targets Select switch and verify that the time and date are correct.

BE1-DFPR Testing

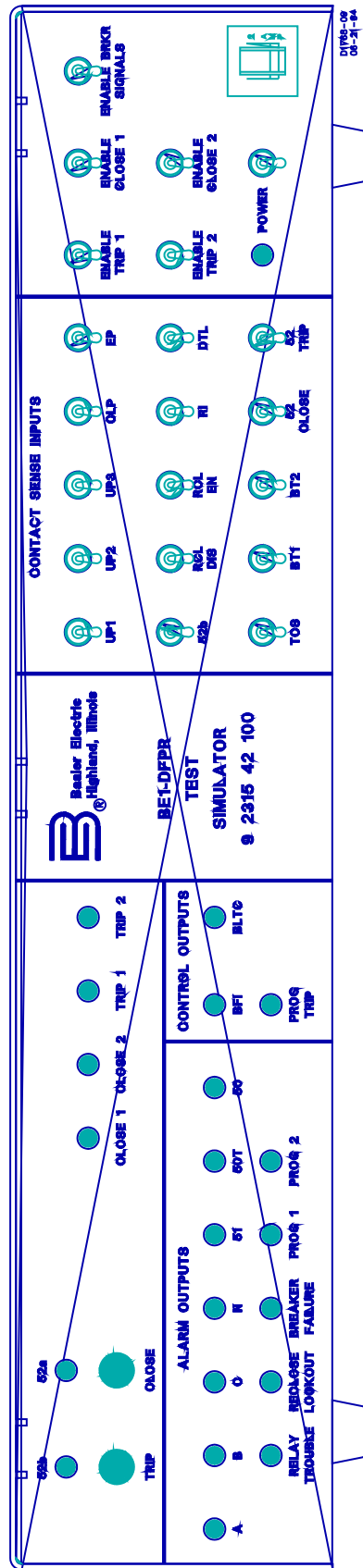

BE1-DFPR Testing

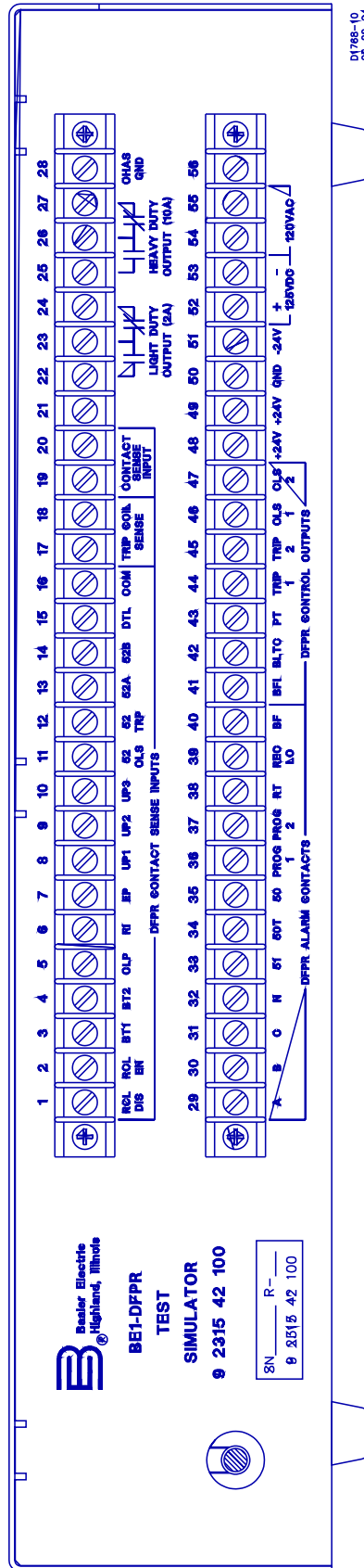

DFPR-6
05-25-94



Becker Electric
Highland, Illinois

BE1-DFPR
TEST
SIMULATOR

9 2315 42 100

SN R-
9 2315 42 100

Figure 5-2. BE1-DFPR Test Simulator, Rear View

BE1-DFPR Testing

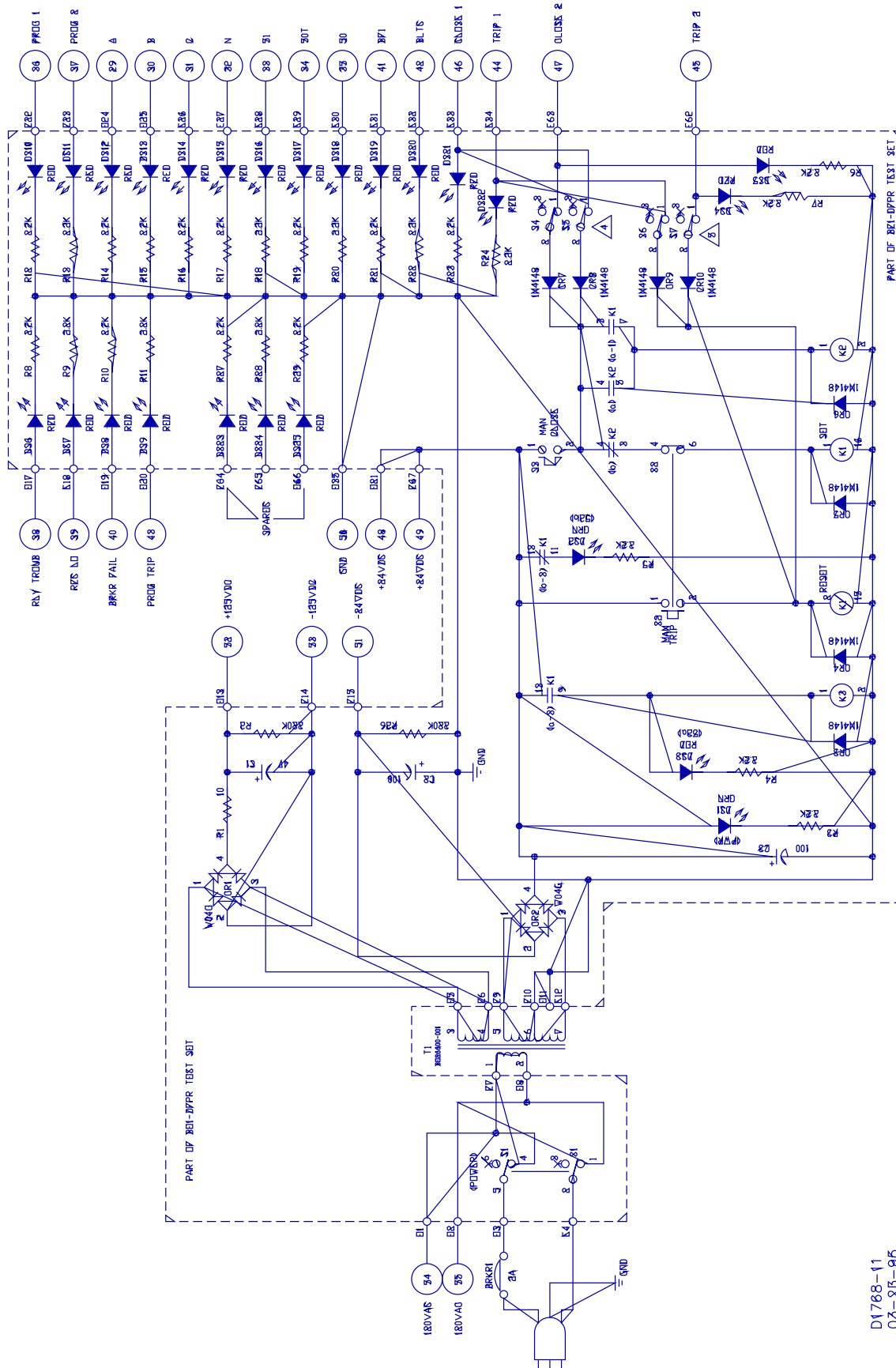

D1788-11
02-215-05

Figure 5-3. BE1-DFPR Test Simulator, Schematic Diagram (Sheet 1 of 2)

BE1-DFPR Testing

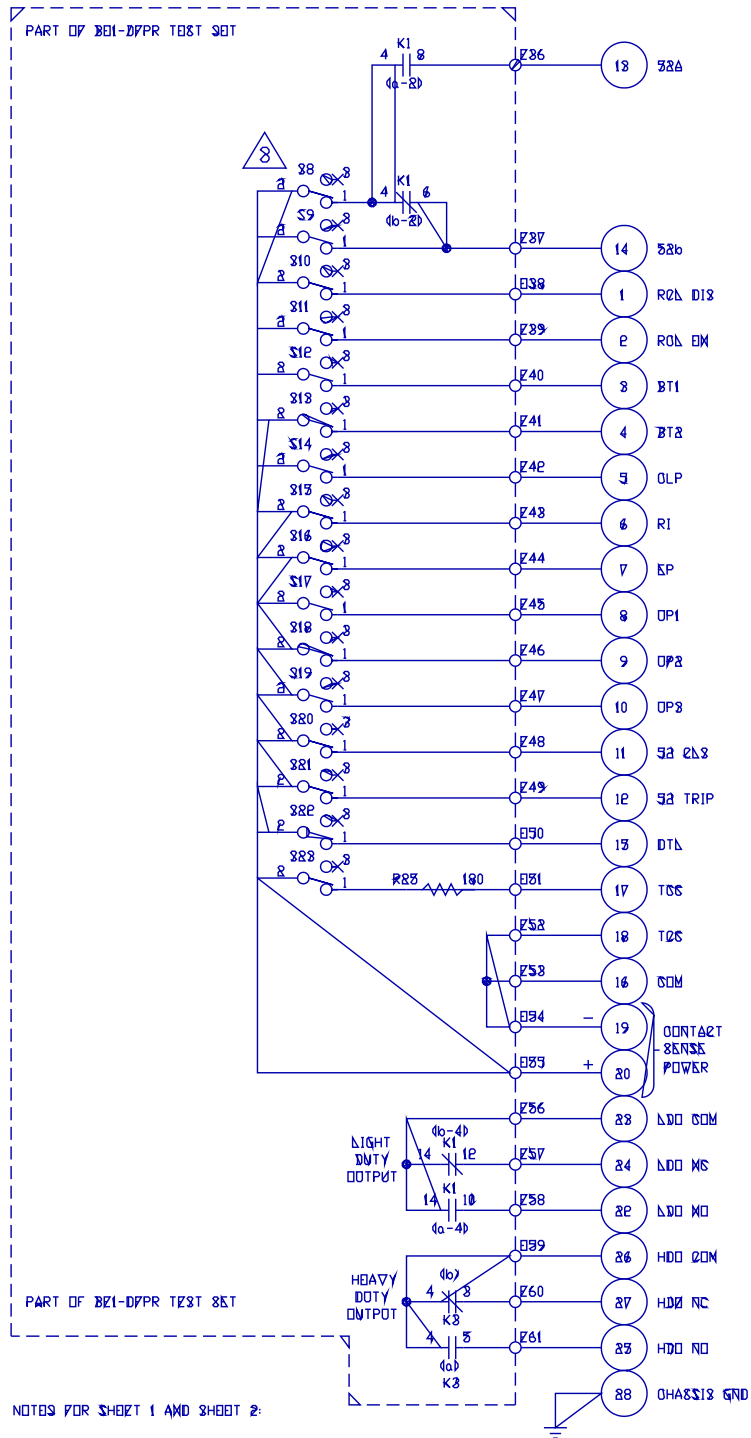

Figure 5-4. BE1-DFPR Test Simulator, Schematic Diagram (Sheet 2 of 2)

BE1-DFPR Testing

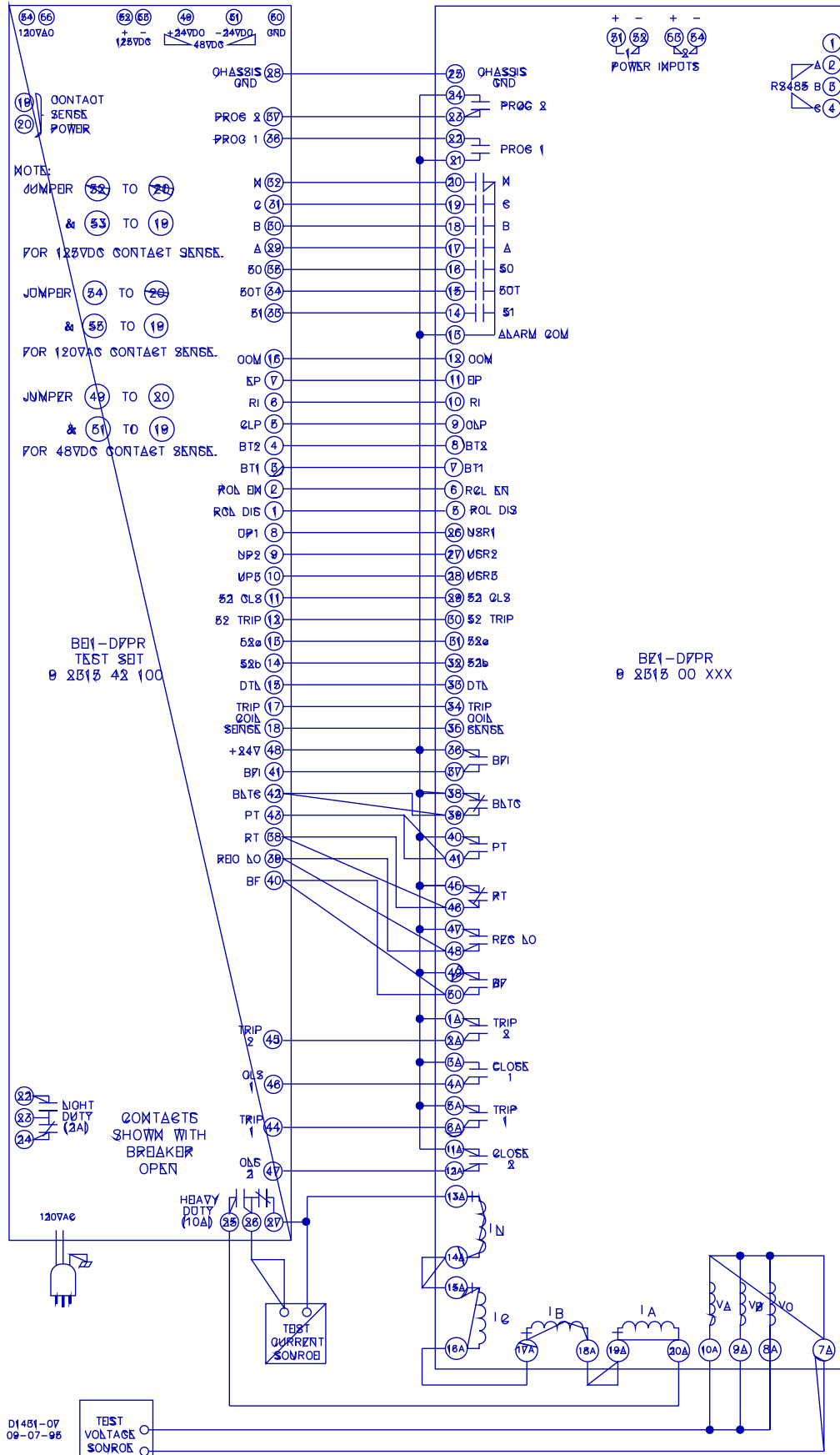

Figure 5-5. Test Setup Diagram

BE1-DFPR Testing

Entering Settings

- Step 1. Perform the Preliminary setup procedure.
- Step 2. Use the Settings Select switch to enter Settings Mode. Only the Address, Baud Rate, CT and PT ratios, Demand Interval, and normal mode settings can be changed on the front panel in Settings Mode. All other settings changes will require a terminal to change them.
- Step 3. To make changes in the settings mode operate the Settings Select switch to bring up the setting to be changed.
- Step 4. Operate the Settings Raise/Yes Lower/No switch to change the setting.
- Step 5. To save the settings you have changed operate (UP) the Status/Targets Select switch and the relay will respond SAVE SETUP?.
- Step 6. Operate (UP) the Status/Targets Select switch again and the relay will respond SETUP SAVED. If you do not wish to save the settings that were changed operate (DOWN) the Status/Target Select switch. The relay will respond NOT SAVED, restore the original settings, and return to the operate mode.
- Step 7. To change all other settings the use of a terminal is required. Hook the terminal up to the front or rear port and execute your terminal program.
- Step 8. Press ESC to bring up the Terminal Access Main Menu.
- Step 9. Press 4, type in the password, and enter to bring up the Review/Edit Settings menu.
- Step 10. From here all of the relay settings can be changed. Enter the screen of the settings you wish to changed and enter the desired settings.
- Step 11. To save the settings press Esc and answer Y to the Save Settings question.
- Step 12. The relay will respond Settings Are Saved, Returning To Last Screen on the terminal. Press ESC again to return to the Review/Edit Settings menu.
- Step 13. Verify that the settings are keep during a loss of power by removing and then applying the input power.
- Step 14. Use the terminal to verify that all of the settings were saved.

Pickup Verification

- Step 1. Perform the Preliminary setup procedure.

51 Pickup

- Step 2. From the Review/Edit Settings Menu on the terminal, select 2, 5, 8, I, or L to enter the Tripping Logic screen for the desired settings group.
- Step 3. Enter a N in all Trip 1 locations except 51P and 51N. Enter a Y in the 51P and 51N locations. Press ESC to save these settings, then press ESC again to return to the Review/Edit Settings menu. This disables all other functions from tripping the relay so just the 51 function can be checked.

BE1-DFPR Testing

- Step 4. From the Review/Edit Settings Menu, select 1, 4, 7, H, or K to enter the Relay Settings screen for the desired settings group.
- Step 5. Enter S for the 51P CURV and 51N CURV settings and enter 0 for 51P TD and 51N TD settings. Press ESC to save these settings, then press ESC again to return to the Review/Edit Settings menu. This will give a fast trip time for the 51P and 51N elements so the pickup can be checked accurately.
- Step 6. Connect a current source to any phase current input or the neutral current input.
- Step 7. Close the breaker on the test set and wait for the RST LED to illuminate on the relay.
- Step 8. Slowly ramp up the current. When the relay trips the current being applied should be within $\pm 2\%$ or 50 ma of the 51P PU setting or 51N PU setting as displayed in the Relay Settings screen.
- Step 9. Return to the Relay Settings screen and return the 51P CURV, 51N CURV, 51P TD and 51N TD settings to the desired values. Press ESC to save the settings, then press ESC again to return to the Review/Edit Settings menu.
- Step 10. Return to the Tripping Logic screen and return the Trip 1 settings to the desired values. Press ESC to save the settings, then press ESC again to return to the Review/Edit Settings menu.

50 Pickup

- Step 11. From the Review/Edit Settings Menu on the terminal, select 2, 5, 8, I, or L to enter the Tripping Logic screen for the desired settings group.
- Step 12. Enter a N in all Trip 1 locations except 50P and 50N. Enter a Y in the 50P and 50N locations. Press ESC to save these settings, then press ESC again to return to the Review/Edit Settings menu. This disables all other functions from tripping the relay so just the 50 function can be checked.
- Step 13. Connect a current source to any phase current input or the neutral current input.
- Step 14. Close the breaker on the test set and wait for the RST LED to illuminate on the relay.
- Step 15. Slowly ramp up the current. When the relay trips the current being applied should be within $\pm 5\%$ of the 50P PU setting or 50N PU setting as displayed in the Relay Settings screen.
- Step 16. Return to the Normal Mode Tripping Logic screen and return the Trip 1 settings to the desired values. Press ESC to save the settings, then press ESC again to return to the Review/Edit Settings menu.

50T Pickup

- Step 17. From the Review/Edit Settings Menu on the terminal, select 2, 5, 8, I, or L to enter the Tripping Logic screen for the desired settings group.
- Step 18. Enter a N in all Trip 1 locations except 50TP and 50TN. Enter a Y in the 50TP and 50TN locations. Press ESC to save these settings, then press ESC again to return to the Review/Edit Settings menu. This disables all other functions from tripping the relay so just the 50T function can be checked.
- Step 19. From the Review/Edit Settings Menu on the terminal, select 1, 4, 7, H, or K to enter the Relay Settings screen for the desired settings group.
- Step 20. Enter 0.03 for the 50TP TD and 1.0 for the 50TN TD settings. Press ESC to save these settings, then press ESC again to return to the Review/Edit Settings menu. This will give a fast trip time for the 50TP and 50TN elements so the pickup can be checked accurately.
- Step 21. Connect a current source to any phase current input or the neutral current input.
- Step 22. Close the breaker on the test set and wait for the RST LED to illuminate on the relay.
- Step 23. Slowly ramp up the current. When the relay trips the current being applied should be within $\pm 5\%$ of the 50TP PU setting or 50TN PU setting in the Normal Mode Settings.

BE1-DFPR Testing

- Step 24. Return to the Relay Settings screen and return the 50TP TD and 50TN TD settings to the desired values. Press ESC to save the settings, then press ESC again to return to the Review/Edit Settings menu.
- Step 25. Return to the Tripping Logic screen and return the Trip 1 settings to the desired values. Press ESC to save the settings, then press ESC again to return to the Review/Edit Settings menu.

27 Pickup

- Step 26. From the Review/Edit Settings Menu on the terminal, select 2, 5, 8, I, or L to enter the Tripping Logic screen for the desired settings group.
- Step 27. Enter a N in all Trip 1 locations except 27/59. Enter a Y in the 27/59 location. Press ESC to save these settings, then press ESC again to return to the Review/Edit Settings menu. This disables all other functions from tripping the relay so just the 27/59 function can be checked.
- Step 28. From the Review/Edit Settings Menu on the terminal, select 1, 4, 7, H, or K to enter the Relay Settings screen for the desired settings group.
- Step 29. Enter 1.0 for the 27 TD setting. Press ESC to save these settings, then press ESC again to return to the Review/Edit Settings menu. This will give a fast trip time for the 27 element so the pickup can be checked accurately.
- Step 30. Connect a voltage source to the phase you wish to check. The other two phases will need to be connected to a voltage source with a voltage applied that is greater than the 27 PU setting in the Relay Settings screen.
- Step 31. Close the breaker on the test set and wait for the RST LED to illuminate on the relay.
- Step 32. Slowly ramp down the voltage on one phase. When the relay trips the voltage being applied should be within $\pm 2\%$ of the 27 PU setting in the Relay Settings screen.
- Step 33. Return to the Relay Settings screen and return the 27 TD settings to the desired values. Press ESC to save the settings, then press ESC again to return to the Review/Edit Settings menu.
- Step 34. Return to the Tripping Logic screen and return the Trip 1 settings to the desired values. Press ESC to save the settings, then press ESC again to return to the Review/Edit Settings menu.

81 Pickup

- Step 35. From the Review/Edit Settings Menu on the terminal, select 2, 5, 8, I, or L to enter the Tripping Logic screen for the desired settings group.
- Step 36. Enter a N in all Trip 1 locations except 81. Enter a Y in the 81 location. Press ESC to save these settings, then press ESC again to return to the Review/Edit Settings menu. This disables all other functions from tripping the relay so just the 81 function can be checked.
- Step 37. From the Review/Edit Settings Menu, select 1, 4, 7, H, or K to enter the Relay Settings screen for the desired settings group.
- Step 38. Enter 0.10 for the 81 T TD and enter 1 for the 81 R TD settings. Press ESC to save these settings, then press ESC again to return to the Review/Edit Settings menu. This will give a fast trip and restore times for the 81 element so the pickup and dropout can be checked accurately.
- Step 39. Connect the voltage inputs in parallel and connect a frequency source to the voltage inputs. Set the voltage level to a level greater than the 81 INH setting in the Relay Settings screen.

BE1-DFPR Testing

- Step 40. Close the breaker on the test set and wait for the RST LED to illuminate on the relay.
- Step 41. Slowly ramp down the frequency. When the relay trips the frequency being applied should be within .01 Hz of the 81 T HZ setting in the Relay Settings screen.
- Step 42. Slowly ramp up the frequency. When the relay recloses the breaker the frequency applied should be within .01 of the 81 R HZ setting in the Relay Settings screen. (Note you will need to ramp up the frequency very slowly to get an accurate measurement since the minimum timer setting is one second)
- Step 43. Return to the Relay Settings screen and return the 81 T TD and 81 R TD settings to the desired values. Press ESC to save the settings, then press ESC again to return to the Review/Edit Settings menu.
- Step 44. Return to the Tripping Logic screen and return the Trip 1 settings to the desired values. Press ESC to save the settings, then press ESC again to return to the Review/Edit Settings menu.

59 Pickup

- Step 45. From the Review/Edit Settings Menu on the terminal, select 2, 5, 8, I, or L to enter the Tripping Logic screen for the desired settings group.
- Step 46. Enter a N in all Trip 1 locations except 27/59. Enter a Y in the 27/59 location. Press ESC to save these settings, then press ESC again to return to the Review/Edit Settings menu. This disables all other functions from tripping the relay so just the 27/59 function can be checked.
- Step 47. From the Review/Edit Settings Menu on the terminal, select 1, 4, 7, H, or K to enter the Relay Settings screen for the desired settings group.
- Step 48. Enter 1.0 for the 59 TD setting. Press ESC to save these settings, then press ESC again to return to the Review/Edit Settings menu. This will give a fast trip time for the 59 element so the pickup can be checked accurately.
- Step 49. Connect a voltage source to the phase you wish to check. The other two phases will need to be connected to a voltage source with a voltage applied that is less than the 59 PU setting in the Relay Settings screen.
- Step 50. Close the breaker on the test set and wait for the RST LED to illuminate on the relay.
- Step 51. Slowly ramp up the voltage on one phase. When the relay trips the voltage being applied should be within $\pm 2\%$ of the 59 PU setting in the Relay Settings screen.
- Step 52. Return to the Relay Settings screen and return the 59 TD settings to the desired values. Press ESC to save the settings, then press ESC again to return to the Review/Edit Settings menu.
- Step 53. Return to the Tripping Logic screen and return the Trip 1 settings to the desired values. Press ESC to save the settings, then press ESC again to return to the Review/Edit Settings menu.

Timing Verification

- Step 1. Perform the Preliminary setup procedure.

51 Timings

- Step 2. From the Review/Edit Settings Menu on the terminal, select 2, 5, 8, I, or L to enter the Tripping Logic screen for the desired settings group.
- Step 3. Enter a N in all Trip 1 locations except 51P and 51N. Enter a Y in the 51P and 51N locations. Press ESC to save these settings, then press ESC again to return to the Review/Edit Settings

BE1-DFPR Testing

menu. This disables all other functions from tripping the relay so just the 51 function can be checked.

- Step 4. Connect a current source to any phase current input or the neutral current input.
- Step 5. Close the breaker on the test set and wait for the RST LED to illuminate on the relay.
- Step 6. Apply an appropriate amount of current to trip the relay and measure the time from when the current is applied until the Trip 1 contacts close. This timing should fall on the curve diagram for the curve you have selected in the Relay Settings screen with the Time Dial you have selected and the multiple of tap the current was that was applied.
- Step 7. Return to the Tripping Logic screen and return the Trip 1 settings to the desired values. Press ESC to save the settings, then press ESC again to return to the Review/Edit Settings menu.

50 Timings

- Step 8. From the Review/Edit Settings Menu on the terminal, select 2, 5, 8, I, or L to enter the Tripping Logic screen for the desired settings group.
- Step 9. Enter a N in all Trip 1 locations except 50P and 50N. Enter a Y in the 50P and 50N locations. Press ESC to save these settings, then press ESC again to return to the Review/Edit Settings menu. This disables all other functions from tripping the relay so just the 50 function can be checked.
- Step 10. Connect a current source to any phase current input or the neutral current input.
- Step 11. Close the breaker on the test set and wait for the RST LED to illuminate on the relay.
- Step 12. Apply an appropriate amount of current to trip the relay and measure the time from when the current is applied until the Trip 1 contacts close. This timing should be between the minimum and maximum levels as shown in Figure 1-2.
- Step 13. Return to the Tripping Logic screen and return the Trip 1 settings to the desired values. Press ESC to save the settings, then press ESC again to return to the Review/Edit Settings menu.

50T Timings

- Step 14. From the Review/Edit Settings Menu, select 2, 5, 8, I, or L to enter the Tripping Logic screen for the desired settings group.
- Step 15. Enter a N in all Trip 1 locations except 50TP and 50TN. Enter a Y in the 50TP and 50TN locations. Press ESC to save these settings, then press ESC again to return to the Review/Edit Settings menu. This disables all other functions from tripping the relay so just the 50T function can be checked.
- Step 16. Connect a current source to any phase current input or the neutral current input.
- Step 17. Close the breaker on the test set and wait for the RST LED to illuminate on the relay.
- Step 18. Apply an appropriate amount of current to trip the relay and measure the time from when the current is applied until the Trip 1 contacts close. This timing should be within $\pm 5\%$ or 25 ms of the time delay setting that is set in the Relay Settings screen (50TP TD for a phase timing and 50TN TD for a neutral timing).
- Step 19. Return to the Tripping Logic screen and return the Trip 1 settings to the desired values. Press ESC to save the settings, then press ESC again to return to the Review/Edit Settings menu.

27 Timings

- Step 20. From the Review/Edit Settings Menu on the terminal, select 2, 5, 8, I, or L to enter the Tripping Logic screen for the desired settings group.
- Step 21. Enter N in all Trip 1 locations except 27/59. Enter Y in the 27/59 location. Press ESC to save these settings, then press ESC again to return to the Review/Edit Settings menu. This disables all other functions from tripping the relay so just the 27/59 function can be checked.

BE1-DFPR Testing

- Step 22. Connect a voltage source to the phase you wish to check. The other two phases will need to be connected to a voltage source with a voltage applied that is greater than the 27 setting in the Normal Mode Settings.
- Step 23. Close the breaker on the test set and wait for the RST LED to illuminate on the relay.
- Step 24. Step the voltage down on one phase to a point lower than the 27 PU voltage and measure the time from when the voltage is stepped down until the Trip 1 contacts close. This timing should be within $\pm 5\%$ or 30 milliseconds, whichever is greater, of the 27 TD setting that is set in the Relay Settings screen.
- Step 25. Return to the Tripping Logic screen and return the Trip 1 settings to the desired values. Press ESC to save the settings, then press ESC again to return to the Review/Edit Settings menu.

81 Timings

- Step 26. From the Review/Edit Settings Menu, select 2, 5, 8, I, or L to enter the Tripping Logic screen for the desired settings group.
- Step 27. Enter a N in all Trip 1 locations except 81. Enter a Y in the 81 location. Press ESC to save these settings, then press ESC again to return to the Review/Edit Settings menu. This disables all other functions from tripping the relay so just the 81 function can be checked.
- Step 28. Connect the voltage inputs in parallel and connect a frequency source to the voltage inputs. Set the voltage level to a level greater than the 81 INH setting in the Normal Mode Settings.
- Step 29. Close the breaker on the test set and wait for the RST LED to illuminate on the relay.
- Step 30. Step the frequency down to a point below the 81 T HZ setting and measure the time from when the frequency is stepped down until the Trip 1 contacts close. This timing should be within $\pm 10\%$ or 50 ms of the 81 T TD setting that is set in the Relay Settings screen.
- Step 31. Step the frequency up to a point above the 81 R HZ setting and measure the time from when the frequency is stepped up until the Close 1 contacts close. This timing should be within $\pm 5\%$ or 200 ms, whichever is greater, of the 81 R TD setting that is set in the Relay Settings screen.
- Step 32. Return to the Tripping Logic screen and return the Trip 1 settings to the desired values. Press ESC to save the settings, then press ESC again to return to the Review/Edit Settings menu.

59 Timings

- Step 33. From the Review/Edit Settings Menu on the terminal, select 2, 5, 8, I, or L to enter the Tripping Logic screen for the desired settings group.
- Step 34. Enter N in all Trip 1 locations except 27/59. Enter Y in the 27/59 location. Press ESC to save these settings, then press ESC again to return to the Review/Edit Settings menu. This disables all other functions from tripping the relay so just the 27/59 function can be checked.
- Step 35. Connect a voltage source to the phase you wish to check. The other two phases will need to be connected to a voltage source with a voltage applied that is less than the 59 setting in the Normal Mode Settings.
- Step 36. Close the breaker on the test set and wait for the RST LED to illuminate on the relay.
- Step 37. Step the voltage up on one phase to a point greater than the 59 PU voltage and measure the time from when the voltage is stepped up until the Trip 1 contacts close. This timing should be within $\pm 5\%$ or 30 milliseconds, whichever is greater, of the 59 TD setting that is set in the Relay Settings screen.
- Step 38. Return to the Tripping Logic screen and return the Trip 1 settings to the desired values. Press ESC to save the settings, then press ESC again to return to the Review/Edit Settings menu.

Reclose Timers

- Step 39. Close the RI switch on the test set. Connect a voltage source to the voltage inputs and apply a voltage that is greater than the 27 PU setting in the Relay Settings screen.

BE1-DFPR Testing

- Step 40. Close the breaker on the test set and wait for the RST LED to illuminate on the relay.
- Step 41. Trip the breaker on the test set and measure the time from when the breaker is tripped until the Close 1 contacts close. Observe that the Reclosing 1 LED on the front panel illuminates. This time should be within 5% or 30 milliseconds, whichever is greater, of the desired 79 1 TD setting in the Relay Settings screen.
- Step 42. Initiate a Reclosing sequence. When the Reclosing 1 LED illuminates, trip the breaker on the test set again. Measure the time from when the breaker in the test set opens until the CLOSE 1 contacts close. Observe that the Reclosing 2 LED illuminates. This time should be within 5% or 30 milliseconds, whichever is greater, of the desired 79 2 TD setting in the Relay Settings screen.
- Step 43. Initiate a Reclosing sequence. When the Reclosing 2 LED illuminates, trip the breaker on the test set again. Measure the time from when the breaker in the test set opens until the CLOSE 1 contacts close. Observe that the Reclosing 3 LED illuminates. This time should be within 5% or 30 milliseconds, whichever is greater, of the desired 79 3 TD setting in the Relay Settings screen.
- Step 44. Initiate a Reclosing sequence. When the Reclosing 3 LED illuminates, trip the breaker on the test set again. Measure the time from when the breaker in the test set opens until the CLOSE 1 contacts close. Observe that the Reclosing 4 LED illuminates. This time should be within 5% or 30 milliseconds, whichever is greater, of the desired 79 4 TD setting in the Relay Settings screen.

Reset Timer

- Step 45. Close the RI switch on the test set. Connect a voltage source to the voltage inputs and apply a voltage that is greater than the 27 PU setting in the Relay Settings screen.
- Step 46. Close the breaker on the test set and wait for the RST LED to illuminate on the relay.
- Step 47. Initiate a Reclosing sequence. Measure the time from when the test set breaker closes until the relay BLTC contacts close. This time should be within 5% of the desired 79 RESET setting in the Relay Settings screen.

Reclose Fail Timer

- Step 48. Close the RI switch and disable the Close 1 signal on the test set. Connect a voltage source to the voltage inputs and apply a voltage that is greater than the 27 PU setting in the Relay Settings screen.
- Step 49. Close the breaker on the test set and wait for the RST LED to illuminate on the relay.
- Step 50. Initiate a Reclosing sequence. Measure the time that the Close 1 contacts are closed. This time should be within 5% of the 79 RECF setting in the Relay Settings screen.
- Step 51. Enable the Close 1 signal on the test set.

Max Cycle Timer

- Step 52. Close the RI switch on the test set. Connect a voltage source to the voltage inputs and apply a voltage that is greater than the 27 PU setting in the Relay Settings screen.
- Step 53. In the Relay Settings screen, change the 79 max timer to a value that is less than your 79 1TD.
- Step 54. Close the breaker on the test set and wait for the RST LED to illuminate on the relay.
- Step 55. Initiate a reclose sequence. The relay should go to LOCKOUT and not reclose the breaker. Reclosing lockout LED on the relay test set and Reclosing LO LED on the relay front panel should light.

BE1-DFPR Testing

Breaker Duty Timers

Breaker Fail Timer

- Step 1. Disable the TRIP1 and TRIP2 signals on the relay test set. Connect a voltage source to the voltage inputs and apply a voltage that is greater than the 27 PU setting in the Relay Settings screen for the desired settings group. Connect a current source to the current inputs and apply a current greater than 0.5 amperes (5 ampere CT) or 0.1 ampere (1 ampere CT).
- Step 2. Close the breaker on the relay test set and wait for the RST LED on the relay to light.
- Step 3. Close the 52 TRP switch on the relay test set and measure the time from when the TRIP1 contacts close until the BFI contacts close. This time should be within 5% or 10 milliseconds, whichever is greater of the BF TD in the INSTALLATION SETTING screen.

Slow Breaker Trip Timer

- Step 4. Disable the TRIP1 and TRIP2 signals on the relay test set. Connect a voltage source to the voltage inputs and apply a voltage that is greater than the 27 PU setting in the Relay Settings screen for the desired settings group.
- Step 5. Enable the slow breaker trip alarm on programmable alarm 1 in the PROGRAMMABLE ALARMS SETTING screen under the REVIEW/EDIT SETTINGS screen.
- Step 6. Close the breaker on the relay test set and wait for the RST LED on the relay to light.
- Step 7. Close the 52 TRP switch on the relay test set and measure the time from when the TRIP1 contacts close until the Prog Alarm 1 contacts close. This time should be within $\pm 5\%$ or 50 milliseconds, whichever is greater of the slow breaker trip time in the INSTALLATION SETTING screen.

Control Inputs

- Step 1. Perform the Preliminary setup procedure.

BT1

- Step 1. From the Review/Edit Settings Menu on the terminal, select 2, 5, 8, I, or L to enter the Tripping Logic screen for the desired settings group.
- Step 2. Enter a N in all Trip 1 locations except 51N and 50TN. Enter a Y in the 51N and 50TN locations. Press ESC to save these settings, then press ESC again to return to the Review/Edit Settings menu. This disables all other functions from tripping the relay so just the 50 function can be checked.
- Step 4. Connect a current source to the neutral current input.
- Step 5. Close the breaker on the test set and wait for the RST LED to illuminate on the relay.
- Step 6. Close the BT1 switch on the test set and observe that the BT1 LED illuminates on the front panel of the relay.
- Step 7. Apply and appropriate amount of current which would trip the 51N element or the 50TN element. The breaker should not trip.
- Step 8. Remove the current applied to the relay and open the BT1 switch on the test set. The BT1 LED on the front panel should extinguish.

BE1-DFPR Testing

- Step 9. Apply the amount of current that was applied in step 7 and the breaker on the test set should trip.
- Step 10. Remove the current applied to the relay.
- Step 11. Return to the Tripping Logic screen and return the Trip 1 settings to the desired values. Press ESC to save the settings, then press ESC again to return to the Review/Edit Settings menu.

BT2

- Step 12. From the Review/Edit Settings Menu on the terminal, select 2, 5, 8, I, or L to enter the Tripping Logic screen for the desired settings group.
- Step 13. Enter a N in all Trip 1 locations except 50TP and 50TN. Enter a Y in the 50TP and 50TN locations. Press ESC to save these settings, then press ESC again to return to the Review/Edit Settings menu. This disables all other functions from tripping the relay so just the 50 function can be checked.
- Step 14. Connect a current source to the phase current inputs and the neutral current input connected in series.
- Step 15. Close the breaker on the test set and wait for the RST LED to illuminate on the relay.
- Step 16. Close the BT2 switch on the test set and observe that the BT2 LED illuminates on the front panel of the relay.
- Step 17. Apply and appropriate amount of current which would trip the 50T element or the 50TN element. The breaker should not trip.
- Step 18. Remove the current applied to the relay and open the BT2 switch on the test set. The BT2 LED on the front panel should extinguish.
- Step 19. Apply the current amount that was applied in step 17 and the breaker on the test set should trip.
- Step 20. Remove the current applied to the relay.
- Step 21. Return to the Tripping Logic screen and return the Trip 1 settings to the desired values. Press ESC to save the settings, then press ESC again to return to the Review/Edit Settings menu.

RCL DIS And RCL EN

- Step 22. Open the RI switch on the test set. Connect a voltage source to the voltage inputs and apply a voltage that is greater than the 27 PU setting in the Relay Settings screen for the desired settings group.
- Step 23. Close the breaker on the test set and wait for the RST LED to illuminate on the relay.
- Step 24. Momentarily close the RCL DIS switch on the test set and observe that the Reclosing INH LED on the front panel of the relay illuminates.
- Step 25. Trip the breaker on the test set and observe that the relay goes to Lockout. The Reclose Lockout LED on the test set and the Reclosing LO LED on the relay should be illuminated.
- Step 26. Close the breaker and RI switch on the test set and wait for the RST LED to illuminate on the relay.
- Step 27. Momentarily close the RCL EN switch on the test set and observe that the Reclosing INH LED on the front panel of the relay extinguishes.
- Step 28. Trip the breaker on the test set and observe that the relay recloses the breaker after the Reclose 1 timer expires.

DTL

- Step 29. Connect a voltage source to the voltage inputs and apply a voltage that is greater than the 27 PU setting in the Relay Settings screen for the desired settings group.

BE1-DFPR Testing

- Step 30. Close the breaker on the test set and wait for the RST LED to illuminate on the relay.
- Step 31. Close the DTL switch on the test set and observe that the relay goes to Lockout. The Reclose Lockout LED on the test set and the Reclosing LO LED on the relay should be illuminated.

TCS

- Step 32. Connect a voltage source to the voltage inputs and apply a voltage that is greater than the 27 PU setting in the Relay Settings screen for the desired settings group.
- Step 33. Close the breaker on the test set and wait for the RST LED to illuminate on the relay.
- Step 34. Open the TCS switch on the test set and observe that the relay goes to Lockout. The Reclose Lockout and the Breaker Failure LED's on the test set and the Reclosing LO LED on the relay should be illuminated.

52 TRIP and 52 CLOSE

- Step 35. Connect a voltage source to the voltage inputs and apply a voltage that is greater than the 27 PU setting in the Relay Settings screen for the desired settings group.
- Step 36. Close the breaker on the test set and wait for the RST LED to illuminate on the relay.
- Step 37. Momentarily close the 52 Trip switch on the test set and observe that the breaker trips and the relay goes into Lockout. The Reclose Lockout LED on the test set and the Reclosing LO LED on the relay should be illuminated.
- Step 38. Momentarily close the 52 Close switch on the test set and observe that the breaker closes after the Reset timer times out the relay will go into reset. The Reclosing RST LED on the relay should be illuminated.

USR1, USR2, USR3, USR4, and USR5

- Step 39. Select PROGRAMMABLE INPUTS under the REVIEW/EDIT SETTINGS MENU screen.
- Step 40. Select Trigger Event Capture function for the USR1 programmable input.
- Step 41. Momentarily close USR1 input (UP1 on Test Box) and verify that the external event is stored in the REVIEW EVENT SCREEN.

Outputs

Alarm Outputs (Out0, Out1, Out2, Out3, Out4, Out5, And Out6)

- Step 1. Perform the Preliminary setup procedure.
- Step 2. From the Review/Edit Settings menu, select G to enter the Programmable Outputs screen. Select out6 for 51A TARG, 51B TARG, 51C TARG, and 51N TARG. Press ESC to save these settings, then press ESC again to return to the Review/Edit Settings menu.
- Step 3. From the Review/Edit Settings Menu on the terminal, select 2, 5, 8, I, or L to enter the Tripping Logic screen for the desired settings group.
- Step 4. Enter a N in all Trip 1 locations except 51P and 51N. Enter a Y in the 51P and 51N locations. Press ESC to save these settings, then press ESC again to return to the Review/Edit Settings menu. This disables all other functions from tripping the relay so that just the 51 function can be checked.
- Step 5. Connect a current source to the phase A current input.
- Step 6. Close the breaker on the test set and wait for the RST LED to illuminate on the relay.
- Step 7. Apply an appropriate current to trip the breaker. When the relay trips the 51 LED should illuminate.
- Step 8. Repeat step 5 through 7 for phases B and C and for the neutral current inputs.
- Step 9. Return to the Tripping Logic screen and return the Trip 1 settings to the desired values. Press ESC

BE1-DFPR Testing

to save the settings, then press ESC again to return to the Review/Edit Settings menu.

Step 10. Repeat Steps 2 through 9 for the 50 and 50T elements.

Relay Trouble

Step 11. Turn power off to the relay and the Relay Trouble LED on the test set should illuminate.

Reclose Lockout

Step 12. Open the RI switch on the test set.

Step 13. Close the breaker on the test set and wait for the RST LED to illuminate on the relay.

Step 14. Trip the breaker on the test set and observe that the relay goes to lockout. The Reclose Lockout LED on the test set and the Reclosing LO on the front panel should be illuminated.

Breaker Failure

Step 15. Disable the close output on the test set.

Step 16. Apply an appropriate amount of current to trip the relay and after the relay trips leave the current applied. After the Breaker Failure time delay expires the Breaker Failure LED should illuminate.

Programmable Alarm #1 & #2

Step 17. The conditions for this output to close are on the Programmable Alarms screen on the terminal. The output will close if the condition is true and the item is marked Y under one of the alarms.

BFI (Breaker Failure Initiate Output)

Step 18. Disable the close output on the test set.

Step 19. Apply an appropriate amount of current to trip the relay. After the relay trips, leave the current applied. When the relay gives the trip signal the BFI LED should illuminate also. After the Breaker Failure time delay expires the Breaker Failure LED should illuminate and the BFI LED will extinguish.

BLTC

Step 20. The BLTC LED should be illuminated any time that the relay is in Reset or Lockout mode. Anytime the relay is in a reclosing sequence the BLTC LED will extinguish.

Programmable Trip

Step 21. The conditions for this output to close is on the Programmable Trip Output screen on the terminal. The output will close if the relay trips and that element is marked Y under one of the trips.

All phases of the operational test procedures are complete. Self test continues on the following page.

BE1-DFPR Testing

SELF TEST

To execute the self test diagnostic program (TEST), perform the following steps.

- Step 1. Perform the Preliminary setup procedure.
- Step 2. Operate the Settings Select switch and observe that SETTINGS MDE is indicated on the display.
- Step 3. Operate the Settings Select switch until TST MODE NO is indicated on the display.
- Step 4. Operate (UP) the Settings Raise/Yes Lower/No switch and observe that TST MODE YES is indicated on the display.
- Step 5. Operate (UP) the Settings Raise/Yes Lower/No switch slightly before the Status/Targets Reset and observe that TEST MODE is indicated on the display.
- Step 6. Close the following listed contact sensing inputs and observe that the associated front panel LED is turned ON.

Contact Sensing Input	Front Panel LED
UP1	Reclosing 1
UP2	Reclosing 2
UP3	Reclosing 3
CLP	CLP
EP	EP
52a	51A
52b	51B
RCL DIS	INH
RCL EN	RST
RI	81
DTL	LO
TCS	STATUS
BT1	BT1
BT2	BT2
52 CLOSE	CLOSE
52 TRIP	TRIP

- Step 7. Verify that all the contact sensing inputs are open. Operate (UP) and hold the Status/Targets Reset switch. Observe that the relay completes the pre-programmed test sequence. If an option is not present, the program bypasses that particular test. The sequence of events (tests) is as follows:

- 51A Overcurrent LED ON
- 51B Overcurrent LED ON
- 51C Overcurrent LED ON
- 51N Overcurrent LED ON
- 50TA Overcurrent LED ON
- 50TB Overcurrent LED ON
- 50TC Overcurrent LED ON
- 50TN Overcurrent LED ON
- 1 Reclosing LED ON
- 2 Reclosing LED ON
- 3 Reclosing LED ON
- 4 Reclosing LED ON
- LO Reclosing LED ON
- RST Reclosing LED ON
- INH Reclosing LED ON
- 81 Reclosing LED ON
- CLP Control LED ON
- EP Control LED ON
- BT1 Control LED ON
- BT2 Control LED ON
- TRIP LED ON
- CLOSE LED ON
- 27/59 LED ON
- STATUS LED ON
- CLOSE 1 contacts close
- CLOSE 2 contacts close

BE1-DFPR Testing

- TRIP 1 contacts close
- TRIP 2 contacts close
- Alarm Output A contacts close
- Alarm Output B contacts close
- Alarm Output C contacts close
- Alarm Output N contacts close
- Alarm Output 51 contacts close
- Alarm Output 50T contacts close
- Alarm Output 50 contacts close
- BFI contacts close
- BLTC contacts open
- RELAY TROUBLE contacts open
- RECLOSE LOCKOUT contacts close
- BREAKER FAILURE contacts close
- PROG 1 contacts close
- PROG 2 contacts close
- PROG TRP contacts close
- Allows step 6 to be performed

Step 8. To terminate the test, operate (DOWN) the Settings Raise/Lower switch.

Self test is complete. Trip test continues on the following page.

BE1-DFPR Testing

TRIP TEST

- Step 1. Operate the Settings Select switch and observe that SETTINGS MDE is indicated on the display.
- Step 2. Operate the Settings Select switch until TST MODE NO is displayed on the display.
- Step 3. Operate (up) the Settings Raise/Yes Lower/No switch and observe that TST MODE YES is indicated on the display.
- Step 4. (There is a five second timer that starts each time the Status/Targets Reset switch is operated down. If the timer times out, the relay loops back to TEST MODE YES displayed on the display.) Operate (down) the Status/Targets Reset switch and observe that TEST TRIP? is displayed on the display.
- Step 5. Operate (down) the Status/Targets Reset switch and observe that ARE YOU SURE is displayed on the display.
- Step 6. Operate (down) the Status/Targets Reset switch and observe that TRIP TESTED is displayed on the display.

Trip test is complete. Loading factory default settings continues on the following page.

BE1-DFPR Testing

LOADING FACTORY DEFAULT SETTINGS

Factory default settings are primarily used during factory test. The factory default settings are:

Normal, AUX 1, AUX 2, AUX3, And Aux4 Settings

51 PU	= 2.5 A
51P CURV	= E
51P TD	= 2.0 SEC
51N PU	= 2.5 A
51N CURV	= E
51N TD	= 2.0 SEC
50P PU	= 10.0 A
50N PU	= 10.0 A
50TP PU	= 5.0 A
50TP TD	= 1.00 SEC
50TN PU	= 5.0 A
50TN TD	= 2.0 SEC
81 THZ	= 59.50 HZ
81 TTD	= 0.50 SEC
81 RHZ	= 59.90 HZ
81 RTD	= 10 SEC
81 UV	= 40 V
27 PU	= 50 V
27 TD	= 5 SEC
59 PU	= 150 V
59 TD	= 1.0 SEC
79 1 TD	= 2.0 SEC
79 2 TD	= 4.0 SEC
79 3 TD	= 6.0 SEC
79 4 TD	= 8.0 SEC
79 RST	= 3.0 SEC
79 RECF	= 5.0 SEC
79 MAX	= 250 SEC
ALL RECLOSE LOGIC	= YES
ALL TRIPPING LOGIC	= YES

Installation Settings

CT PRI	= 5000 A
CT SEC	= 5 A
NCT PRI	= 5000 A
NCT SEC	= 5 A
VT PRI	= 1000 V
VT SEC	= 100 V
3/1 PH WYE/DELTA	= 3 (3 = 3PH WYE, 2 = 2PH DELTA, 1= 1PH)
DEMAND T	= 1 MIN
BREAKER OP TIME	= 0.000 SEC
SELECT i2t / it	= 0 (0 = I ² T, 1 = IT)
MAX i2t / it	= 0.0e0 AMP ² SEC (0 = INHIBIT)
AUX 1 SET TIME	= 0 (0 = INHIBIT)
BREAKER FAIL TD	= 0.50 SEC
SLOW BKR TRIP	= 1.00 SEC
MAX BKR OPERATIONS	= 0 (0 = INHIBIT)
ALM BKR OPERATIONS	= 0 (0 = INHIBIT)

Installation Settings - Continued

ADDRESS	= 125
232 BAUD (FRONT PORT)	= 19200
232 BAUD RATE (REAR PORT)	= 19200
485 BAUD RATE (REAR PORT)	= 9600
52b RECOGNITION TIME	= 2
52a ENABLE	= 0

Other Parameters

RELAY ID	= BE1-DFPR CUSTOMER ID
----------	------------------------

BE1-DFPR Testing

ALL PASSWORDS	= DFPR
ALL PROG TRIP LOGIC	= NO
ALL PROG OUTPUTS	= NO
FRONT PANEL DISPLAY	= YES
ALL PROG INPUTS	= NO

Load Default Settings

- Step 1. Operate the Settings Select switch and observe that SETTINGS MDE is indicated on the display.
- Step 2. Operate the Settings Select switch until TST MODE NO is displayed on the display.
- Step 3. Operate (up) the Settings Raise/Yes Lower/No switch and observe that TST MODE YES is indicated on the display.
- Step 4. Operate (up) the Settings Raise/Yes Lower/No switch slightly before the SETTINGS SELECT switch and observe that LOAD DEF S? is displayed on the display.
- Step 5. Operate (up) the Status/Targets Reset switch and observe that DEF S LOADED is displayed on the display.
- Step 6. To save the settings, operate (up) the Status/Targets Select switch and observe that SAVE SETUP? is displayed on the display.
- Step 7. Operate (up) the Status/Targets Select switch again and observe that SETUP SAVED is displayed on the display.

If you do not want to save the setup, operate (down) the Status/Targets Select switch again and observe that NOT SAVED is displayed on the display.

Loading factory default settings procedures are complete. Resetting demand values continues on the following page.

RESETTING DEMAND VALUES

To reset the demand values from the front panel, perform the following procedures.

- Step 1. Operate the Settings Select switch and observe that SETTINGS MDE is indicated on the display.
- Step 2. Operate the Settings Select switch until RST DMDS NO is displayed on the display.
- Step 3. Operate (up) the Settings Raise/Yes Lower/No switch and observe that RST DMDS YES is indicated on the display.
- Step 4. (There is a five second timer that starts each time the Status/Targets Reset switch is operated down. If the timer times out, the relay loops back to RST DMDS YES displayed on the display.) Operate (down) the Status/Targets Reset switch and observe that RST DEMANDS? is displayed on the display.
- Step 5. Operate (down) the Status/Targets Reset switch and observe that ARE YOU SURE is displayed on the display.
- Step 6. Operate (down) the Status/Targets Reset switch and observe that DEMANDS RST is displayed on the display.
- Step 7. After five seconds, operate the Status/Targets Select switch to return to status mode and verify that the minimum and maximum demands have been reset.

You have now completed all testing.

SECTION 6

MAINTENANCE

GENERAL

BE1-DFPR Distribution Feeder Protection Relays require no preventive maintenance other than a periodic operational test (refer to Section 5 for test procedures) and clock battery replacement (estimated 10 year life). If a relay fails to function properly and is to be repaired in-house, consult the Service Manual (publication number 9 2315 00 620). If factory repair is desired, contact the Customer Service Department of the Power Systems Group, Basler Electric, for a return authorization number prior to shipping.

IN-HOUSE REPAIR

In-house replacement of individual components may be difficult and should not be attempted unless appropriate equipment and qualified personnel are available.

CAUTION

Substitution of printed circuit boards or individual components does not necessarily mean the relay will operate properly. Always test the relay before placing it in operation.

If in-house repair is to be attempted, component values may be obtained from the schematics or the parts list of the Service Manual. Replacement parts may be purchased locally. The quality of replacement parts must be at least equal to that of the original components.

Where special components are involved, Basler Electric part numbers may be obtained from the number stamped on the component or assembly, the schematic, or parts list. These parts may be ordered directly from Basler Electric. When complete boards or assemblies are needed, the following information is required.

1. Relay model and style number
2. Relay serial number
3. Board or assembly
 - a) Part number
 - b) Serial number
 - c) Revision letter
4. The name of the board or assembly.
5. Software version number.

STORAGE

This protective relay contains aluminum electrolytic capacitors which generally have a life expectancy in excess of 10 years at storage temperatures less than 40°C. Typically, the life expectancy of the capacitor is cut in half for every 10°C rise in temperature. Storage life can be extended if, at one-year intervals, power is applied to the relay for a period of thirty minutes.

SECTION 7

MANUAL CHANGE INFORMATION

SUMMARY AND CROSS REFERENCE GUIDE

This section contains information concerning the previous editions of the manual. The substantive changes to date are summarized in Table 7-1.

Table 7-1. Changes

REV	Summary of Changes	Date
A	Added Overvoltage Function to Specifications, Page 1-10; Changed Style Chart, Figure 1-4 to reflect changes in the BE1-DFPR; Changes Figures 2-1, 2-2, and 2-3; Added 59 function to appropriate occurrences of 27 function and added Overvoltage Pickup and Overvoltage Tripping Functional Descriptions to Sections 3 and 5; and added Section 7, <i>Manual Change Information</i> .	Sep 1997
B	Added caution statement about nonvolatile memory.	Aug 2017

 **Basler Electric®**
www.basler.com

12570 State Route 143
Highland IL 62249-1074 USA
Tel: +1 618.654.2341
Fax: +1 618.654.2351
email: info@basler.com

No. 59 Heshun Road Loufeng District (N)
Suzhou Industrial Park
215122 Suzhou
P.R. CHINA
Tel: +86 512.8227.2888
Fax: +86 512.8227.2887
email: chinainfo@basler.com

111 North Bridge Road
15-06 Peninsula Plaza
Singapore 179098
Tel: +65 68.44.6445
Fax: +65 68.44.8902
email: singaporeinfo@basler.com