

INSTRUCTION MANUAL

FOR

DIGITAL UNDERFREQUENCY RELAY

MODEL BE1-81

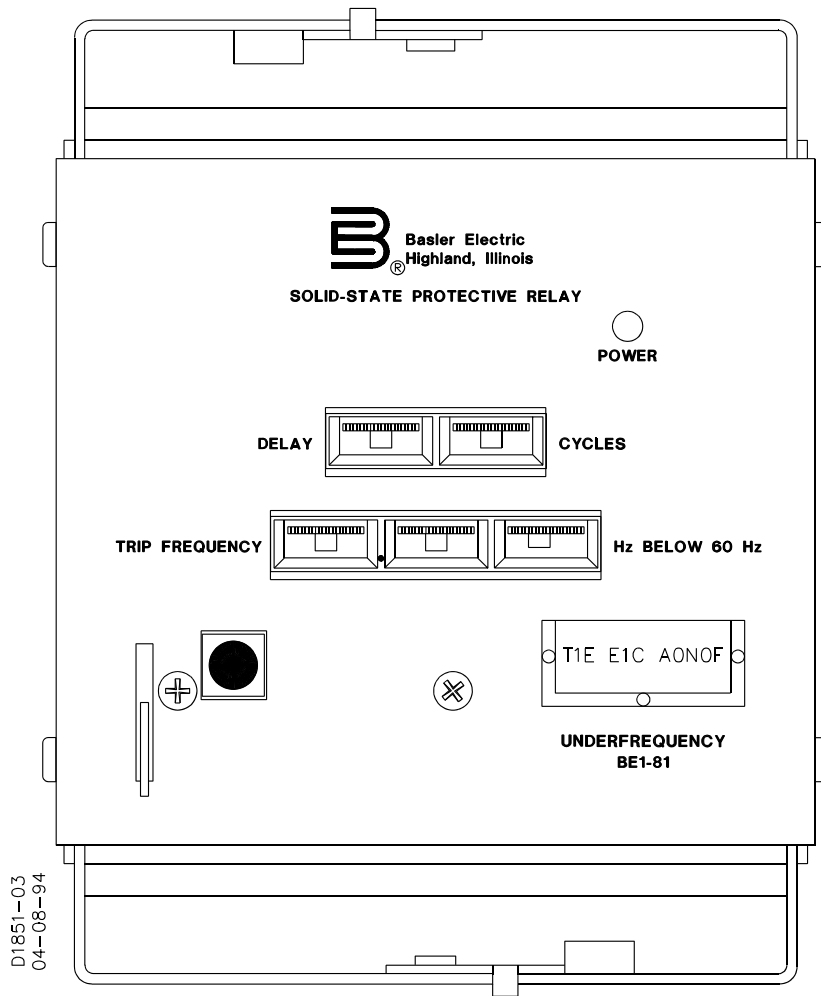

B Basler Electric

Publication: 9 1064 00 990

Revision: B 05/96

INTRODUCTION

This Instruction Manual provides information concerning the operation and installation of the BE1-81 Digital Underfrequency Relay. To accomplish this, the following is provided.

- Specifications
- Functional Characteristics
- Mounting Information
- Connections
- Testing

WARNING!

To avoid personal injury or equipment damage, only qualified personnel should perform the procedures presented in this manual.

First Printing: October 1979

Printed in USA

© 1995, Basler Electric Co., Highland, IL 62249

May 1996

CONFIDENTIAL INFORMATION

OF BASLER ELECTRIC COMPANY, HIGHLAND, IL. IT IS LOANED FOR CONFIDENTIAL USE, SUBJECT TO RETURN ON REQUEST, AND WITH THE MUTUAL UNDERSTANDING THAT IT WILL NOT BE USED IN ANY MANNER DETRIMENTAL TO THE INTEREST OF BASLER ELECTRIC COMPANY.

It is not the intention of this manual to cover all details and variations in equipment, nor does this manual provide data for every possible contingency regarding installation or operation. The availability and design of all features and options are subject to modification without notice. Should further information be required, contact Basler Electric Company, Highland, Illinois.

BASLER ELECTRIC, BOX 269 HIGHLAND, IL 62249 USA

PHONE 618-654-2341

FAX 618-654-2351

CONTENTS

SECTION 1 GENERAL INFORMATION	1-1
Purpose	1-1
Description	1-1
Definite Time Option	1-1
Inverse Time Option	1-1
Relay Assembly	1-1
Model and Style Number Description	1-1
Sample Style Number	1-4
Style Number Identification Chart	1-4
Specifications	1-5
SECTION 2 CONTROLS AND INDICATORS	2-1
SECTION 3 FUNCTIONAL DESCRIPTION	3-1
Functional Description	3-1
Sensing	3-1
Power Supply	3-2
Power Supply Status Contacts	3-2
Voltage Inhibit Circuit	3-2
Input Conditioning Circuit	3-2
Crystal Reference Oscillator	3-2
Synchronizer Circuit	3-3
Reference Circuit	3-3
Period Difference Circuit	3-3
Period Difference To Frequency Difference Circuit	3-3
Threshold Setting Comparator	3-3
Definite Time Delay Circuit (Timing Option E1)	3-3
Inverse Time Delay Circuit (Timing Option D1)	3-3
Relay Output	3-3
Internally Operated Target Driver	3-4
Current Operated Target Driver	3-4
Target Indicator	3-4
SECTION 4 INSTALLATION	4-1
General	4-1
Relay Operating Precautions	4-1
Dielectric Test	4-1
Relay Mounting	4-1
S1 Case, Panel Drilling Diagram, Semi-Flush Mounting	4-2
S1 Case, Outline Dimensions, Front View	4-2
S1 Case, Single-Ended, Semi-Flush Mounting, Side View	4-3
S1 Case, Single-Ended, Semi-Flush Mounting, Outline Dimensions	4-4
S1 Case, Single-Ended, Projection Mounting, Panel Drilling Diagram	4-5
S1 Case, Single-Ended, Projection Mounting, Rear View	4-6
S1 Case, Single-Ended, Projection Mounting, Side View	4-7
S1 Case, Double-Ended, Semi-Flush Mounting, Side View	4-8
S1 Case, Double-Ended, Semi-Flush Mounting, Outline Dimensions	4-9

CONTENTS - CONTINUED

SECTION 4 INSTALLATION - Continued

Relay Mounting - Continued	
S1 Case, Double-Ended, Projection Mounting, Panel Drilling Diagram . . .	4-10
S1 Case, Double-Ended, Projection Mounting, Rear View	4-11
S1 Case, Double-Ended, Projection Mounting, Side View	4-12
Connections	4-13
AC Sensing Input Connections	4-13
DC Control Connections	4-14
Internal Connections, Style Number T?E ?1? A0S5?	4-15
Internal Connections, Style Number T?E ?1C A2S5?	4-16

SECTION 5 TESTING 5-1

General	5-1
Test Setup	5-1
Definite Time Delay (Option E1) Test Procedure	5-2
Inverse Time Delay (Option D1) Test Procedure	5-3

SECTION 6 MAINTENANCE 6-1

General	6-1
In-House Repair	6-1
Storage	6-1
Test Plug	6-2

SECTION 7 Manual Change Information 7-1

SECTION 1

GENERAL INFORMATION

PURPOSE

BE1-81 Digital Underfrequency Relays are single-phase, solid-state, protective devices designed to detect an underfrequency condition and provide an output to actuate external control circuits and/or alarms. Both 50 hertz and 60 hertz styles are available with either definite time delay or inverse time delay characteristics.

DESCRIPTION

BE1-81 relays compare the frequency of the applied voltage with a crystal oscillator reference frequency. When the measured frequency is less than a preset level for a predetermined period of time, external control circuits and/or alarms are actuated by the relay.

Definite Time Option

Definite time option trip frequency settings are set by three front panel thumbwheel switches. Setting ranges are between 0.05 and 5.00 hertz in 0.05 hertz increments below nominal system frequency. The delay time (measured in cycles of the underfrequency waveform) is set by two front panel thumbwheel switches. Delay ranges are from 01 to 99 cycles. The actual trip time is the delay time setting, plus one cycle.

Inverse Time Option

Inverse time option trip frequency settings are also set by three front panel thumbwheel switches and the ranges are from 0.05 to 5.00 hertz in 0.05 hertz increments below nominal system frequency. The inverse time delay characteristic is inversely proportional to the magnitude of the frequency difference between the measured waveform and the trip frequency setting. This time may be adjusted to correspond to a particular characteristic curve by a continuously adjustable front panel time dial. (Refer to Figures 1-1 and 1-2.)

Relay Assembly

The relay assembly is mounted in a drawout cradle and enclosed in a standard, utility style, semi-flush case. Individual circuit components are accessible by removal of the individual printed circuit boards from the relay cradle and using an extender card (Basler part number 9 1655 00 100) to test or troubleshoot. A front panel, electrically operated, manually reset target may be selected to indicate that a fault has occurred and the relay has operated. A wide range of options permits the relay to be specifically tailored to a variety of applications.

MODEL AND STYLE NUMBER DESCRIPTION

BE1-81 Digital Underfrequency Relays electrical characteristics and optional features are defined by a combination of letters and numbers that make up its style number. The model number, together with the style number, describe the options included in a specific device, and appear on the front panel, drawout cradle, and inside the case assembly. Upon receipt of a relay, be sure to check its style number against the requisition and packing list, to see that they agree.

BE1-81 General Information

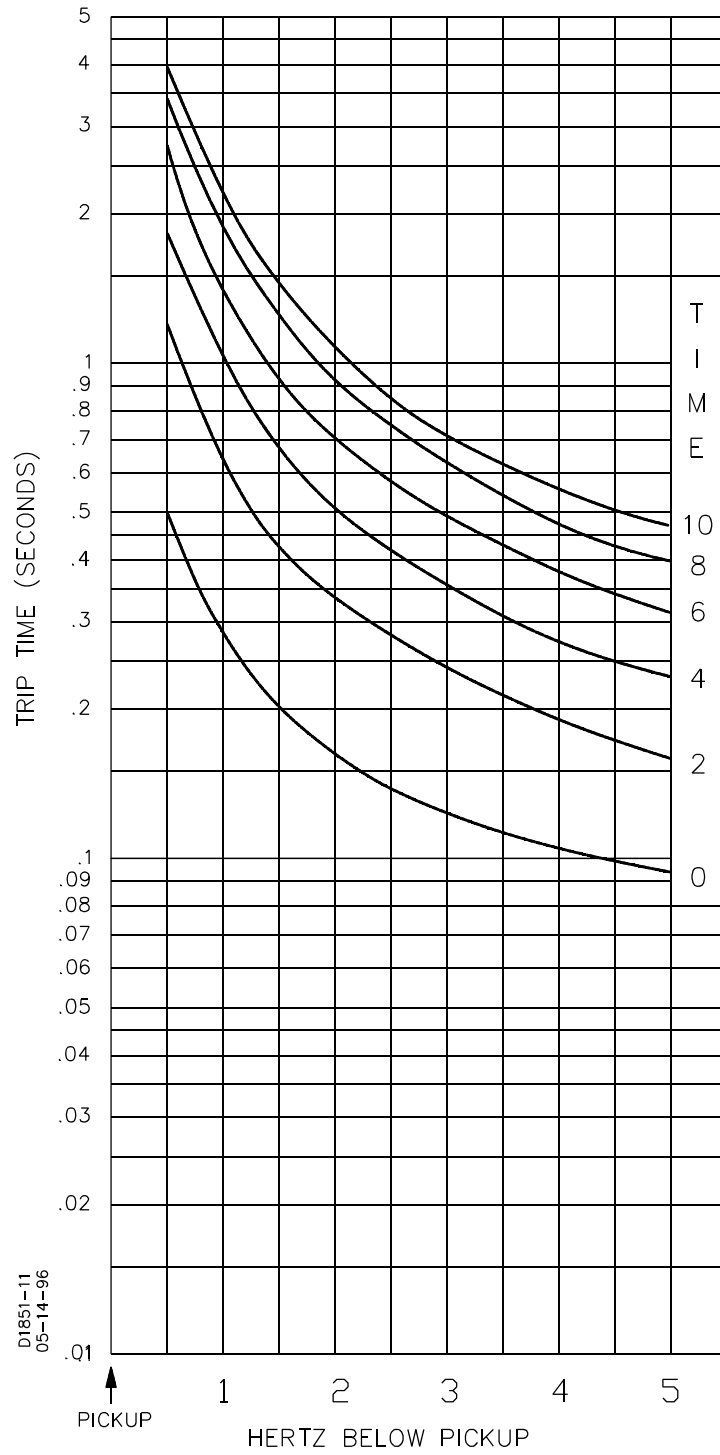

Figure 1-1. Inverse Time Curves, 50 Hertz Option

BE1-81 General Information

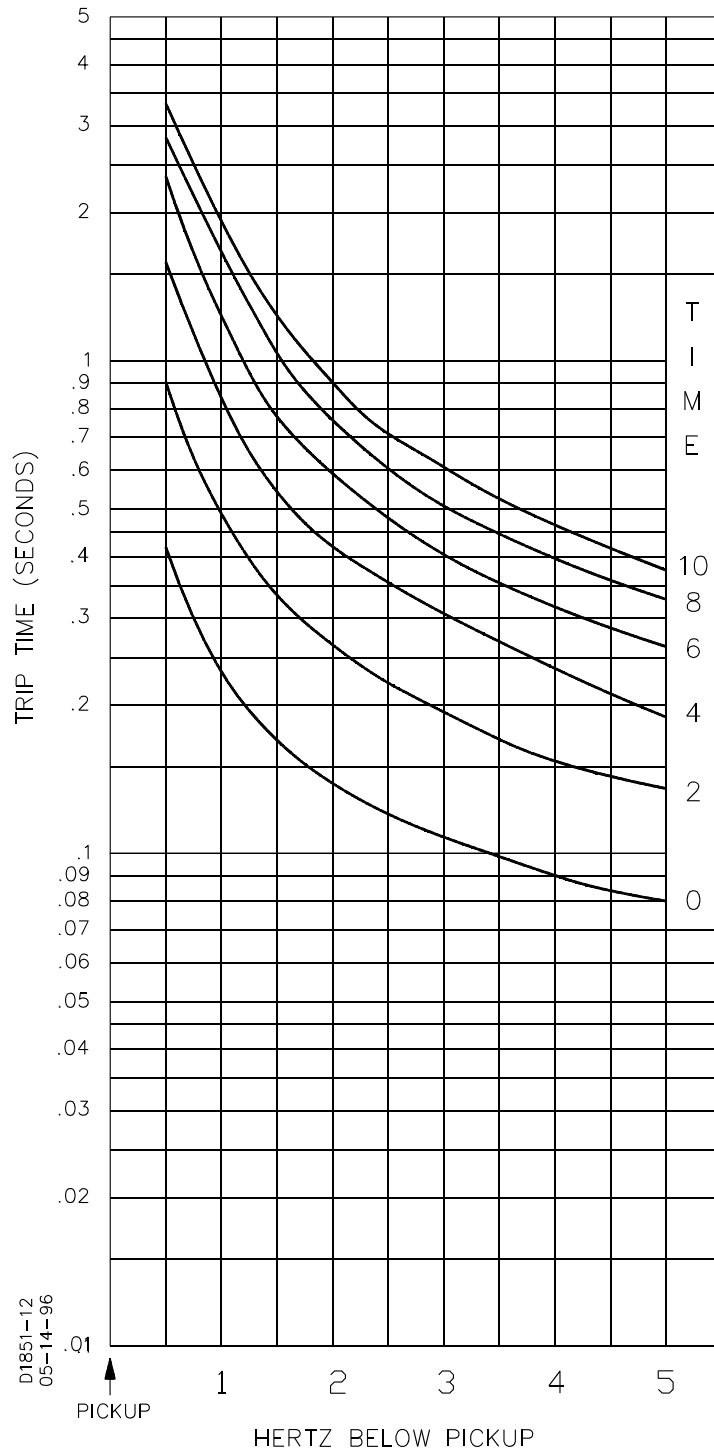

Figure 1-2. Inverse Time Curves, 60 Hertz Option

BE1-81 General Information

Sample Style Number

Style number identification chart (Figure 1-3) defines the electrical characteristics and operational features included in BE1-81 relays. For example, if the style number were **T1E-E1C-A0N0F**, the device would have the following:

- (T) Single phase sensing input type
- (1) 120 Vac, 60 hertz nominal sensing input range
- (E) One normally open relay output
- (E1) Definite time delay
- (C) Internal operating power obtained from 125 Vdc or 100/120 Vac - external source
- (A) One internally operated target
- (0) Internal relay operating power independent of sensed voltage
- (N) No Option 2 available
- (0) No auxiliary output
- (F) Semi-flush mounting

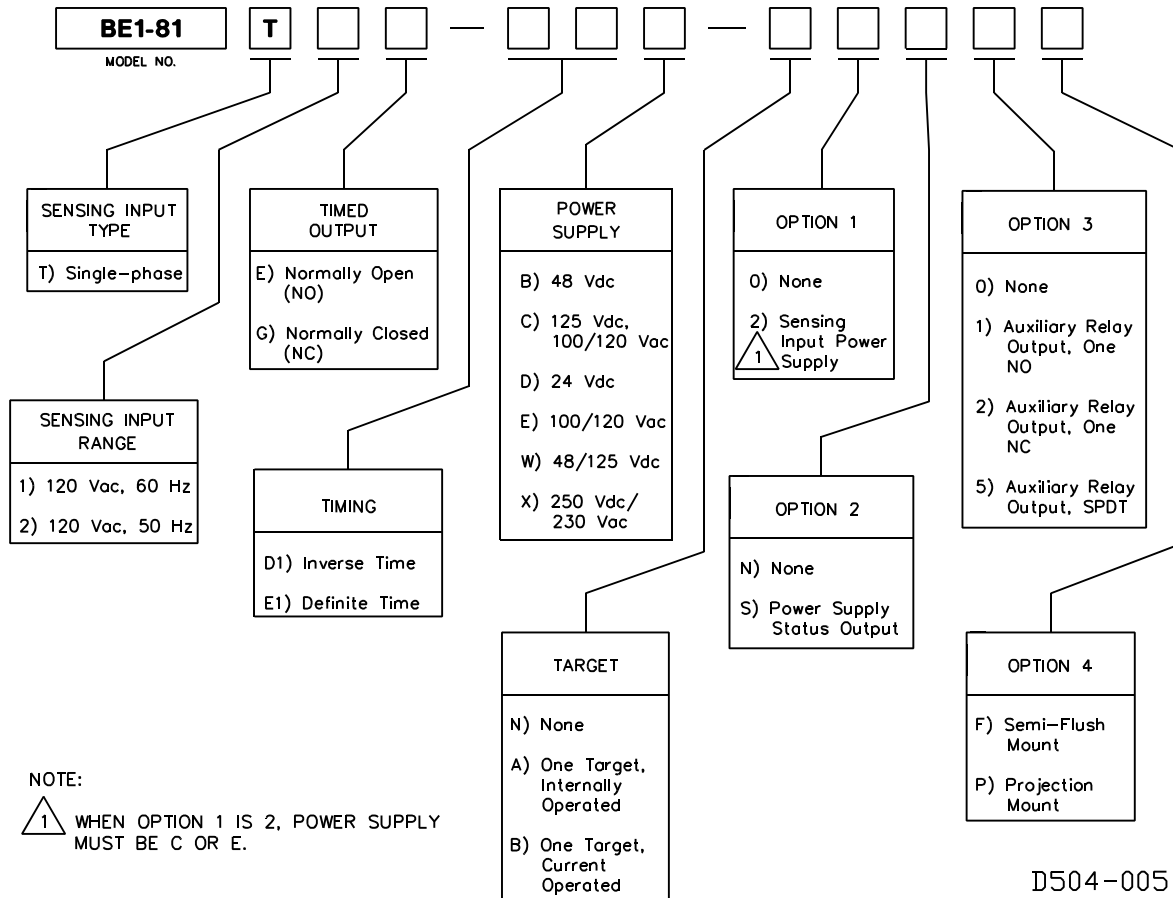

Figure 1-3. Style Number Identification Chart

BE1-81 General Information

SPECIFICATIONS

Power Input

One of the six types of power supplies listed in Table 1-1 may be optionally selected to provide internal relay operating power.

Table 1-1. Power Supply Options

NOMINAL INPUT VOLTAGE	INPUT VOLTAGE RANGE	BURDEN AT NOMINAL VOLTAGE
TYPE B 48 DC	24–60 DC	3.0 W
TYPE C 125 DC 100/120 AC	62–150 DC 90–132 AC	4.0 W 7.5 VA
TYPE D 24 DC	12–32 DC §	3.4 W
TYPE W* 48 DC 125 DC	24–60 DC 62–150 DC	3.6 W 4.3 W
TYPE X 250 DC 230 AC	140–280 DC 190–250 AC	6.8 W 13.2 VA
TYPE E 100/120 AC	90–132 AC	7.6 VA

NOTES:

ALL AC REFERENCES ARE 50/60 Hz.

BURDEN RATINGS ARE FOR RELAY MODEL BE1–81 WITH RELAY IN TRIPPED CONDITION.

WHEN THE "SENSING INPUT POWER SUPPLY" IS SELECTED (OPTION 1 COLUMN OF CHART 1–1), IT IS INTERNALLY CONNECTED TO OPERATE FROM THE SENSING INPUT VOLTAGE APPLIED TO THE RELAY (AT TERMINALS 6 AND 7). THIS OPTION CAN ONLY BE SUPPLIED WHEN POWER SUPPLY OPTION C OR E IS SPECIFIED. THE BURDEN OF THE SELECTED POWER SUPPLY IS ADDED TO THE BURDEN OF THE SENSING INPUT: 2 VA FOR 50 Hz (STYLE T2), OR 1 VA FOR 60 Hz (STYLE T1).

(*) 48 OR 125 VDC INPUT RANGES ARE SELECTABLE BY FIELD ADJUSTABLE LINK.

(§) TYPE D POWER SUPPLY REQUIRES 12.5 VDC TO BEGIN OPERATING. ONCE OPERATING, THE VOLTAGE MAY BE REDUCED.

D1851–13
05–14–96

Frequency Sensing Input

Input sensing circuits are nominally rated 120 Vac at the selected frequency. Relay trip points may be manually set for a single-phase underfrequency trip point from 45 to 50 hertz for the 50 hertz styles, or 55 to 60 hertz for the 60 hertz styles. Both styles are adjustable in 0.05 hertz increments.

Sensing Burden

Burden of the frequency sensing input is 2 VA for 50 hertz styles, and 1 VA for 60 hertz styles.

Target Indicators

Function targets may be specified as either internally operated, or current operated by a minimum of 0.2 ampere through the output trip circuit. When current operated, the output circuit must be limited to 30 amperes for 0.2 seconds, 7 amperes for 2 minutes, and 3 amperes continuously. Internally operated targets must be specified if the breaker control (trip) circuit is ac powered.

Reset Time

Reset is automatic and instantaneous when frequency increases above selected pickup setting. (Target must be manually reset.)

Pickup Setting

Pickup setting is adjusted in Hertz-below-nominal-frequency in 0.05 hertz steps, using three front panel thumbwheel switches.

Pickup Accuracy

The relay will pickup and check timing within 0.030 hertz of the trip point in a 60 hertz system, and within 0.035 hertz in a 50 hertz system.

BE1-81 General Information

Dropout Ratio	99 percent of pickup value (frequency difference).
Temperature Stability	Pickup point variation will not exceed 0.03 hertz over the operating temperature range.
Undervoltage Inhibit	The relay is factory adjusted for an 80 Vac undervoltage inhibit level that prevents nuisance tripping during protected equipment start-up. This level may be internally adjusted by the user for inhibit levels between 40 and 120 Vac except for relays using option 1-2, Sensing Input Power Supply.
Output Circuits	Output contacts are rated as follows:
<u>Resistive:</u>	
120/240 Vac	Make 30 amperes for 0.2 seconds, carry 7 amperes continuously, and break 7 amperes.
250 Vdc	Make and carry 30 amperes for 0.2 seconds, carry 7 amperes continuously, and break 0.3 amperes.
500 Vdc	Make and carry 15 amperes for 0.2 seconds, carry 7 amperes continuously, and break 0.1 amperes.
<u>Inductive:</u>	
120/240 Vac, 125/250 Vdc	Make and carry 30 amperes for 0.2 seconds, carry 7 amperes continuously, and break 0.3 amperes. (L/R = 0.04).
Isolation	1500 Vac at 60 hertz for one minute in accordance with IEC 255-5 and ANSI/IEEE C37.90-1989 (Dielectric Test).
Radio Frequency Interference (RFI)	Maintains proper operation when tested for interference in accordance with ANSI/IEEE C37.90-1989, <i>Trial-Use Standard Withstand Capability of Relay Systems to Radiated Electromagnetic Interference from Transceivers</i> .
UL Recognized	UL Recognized per Standard 508, UL File No. E97033. Note: Output contacts are not UL Recognized for voltages greater than 250 volts.
Surge Withstand Capability	Qualified to ANSI/IEEE C37.90.1-1989 <i>Standard Surge Withstand Capability (SWC) Tests for Protective Relays and Relay Systems</i> .
Operating Temperature	-20°C (-4°F) to +65°C (+149°F).
Storage Temperature	-50°C (-58°F) to +90°C (+194°F).
Shock	In standard tests, the relay has withstood 15 g in each of three mutually perpendicular planes without structural damage or degradation of performance.
Vibration	In standard tests, the relay has withstood 2 g in each of three mutually perpendicular planes, swept over the range of 10 to 500 Hz for a total of six sweeps, 15 minutes each sweep, without structural damage or degradation of performance.
Weight	10.5 pounds net.
Case Size	S1. Dimensions shown in Section 4, <i>Installation</i> .

SECTION 2

CONTROLS AND INDICATORS

GENERAL

Table 2-1 lists and describes the controls and indicators of BE1-81 Digital Underfrequency Relays.

Table 2-1. Controls and Indicators (Refer to Figures 2-1 and 2-2)

Letter	Control or Indicator	Function or Indicator
A	DELAY CYCLES switches (Option E1 only)	Two thumbwheel switches set the time delay (measured in cycles of the underfrequency waveform. The time delay range is from 01 to 99 cycles. False tripping may occur if the delay is set below 3 cycles. Also, the relay will not function if these switches are set at 00.
B	POWER LED	LED lights to indicate that the relay power supply is functioning.
C	TRIP FREQUENCY HZ BELOW 60 HZ switches	Three thumbwheel switches set the trip frequency in increments of 0.05 hertz, between 45 and 50 hertz (50 hertz styles) or 55 and 60 hertz (60 hertz styles). The switch settings then display the frequency (in hertz) below the nominal system frequency at which the relay trip threshold is set.
D	Target Reset Lever	Linkage extending through bottom of front cover that resets magnetically latching target indicators.
E	Target Indicator	Magnetically latching target that indicates that trip current in excess of 0.2 amperes was present and that the associated output relay has been energized.
F	TRIP TIME ADJUST Control (Option D1 only)	Control selects the desired inverse characteristic trip curve.

BE1-81 Controls And Indicators

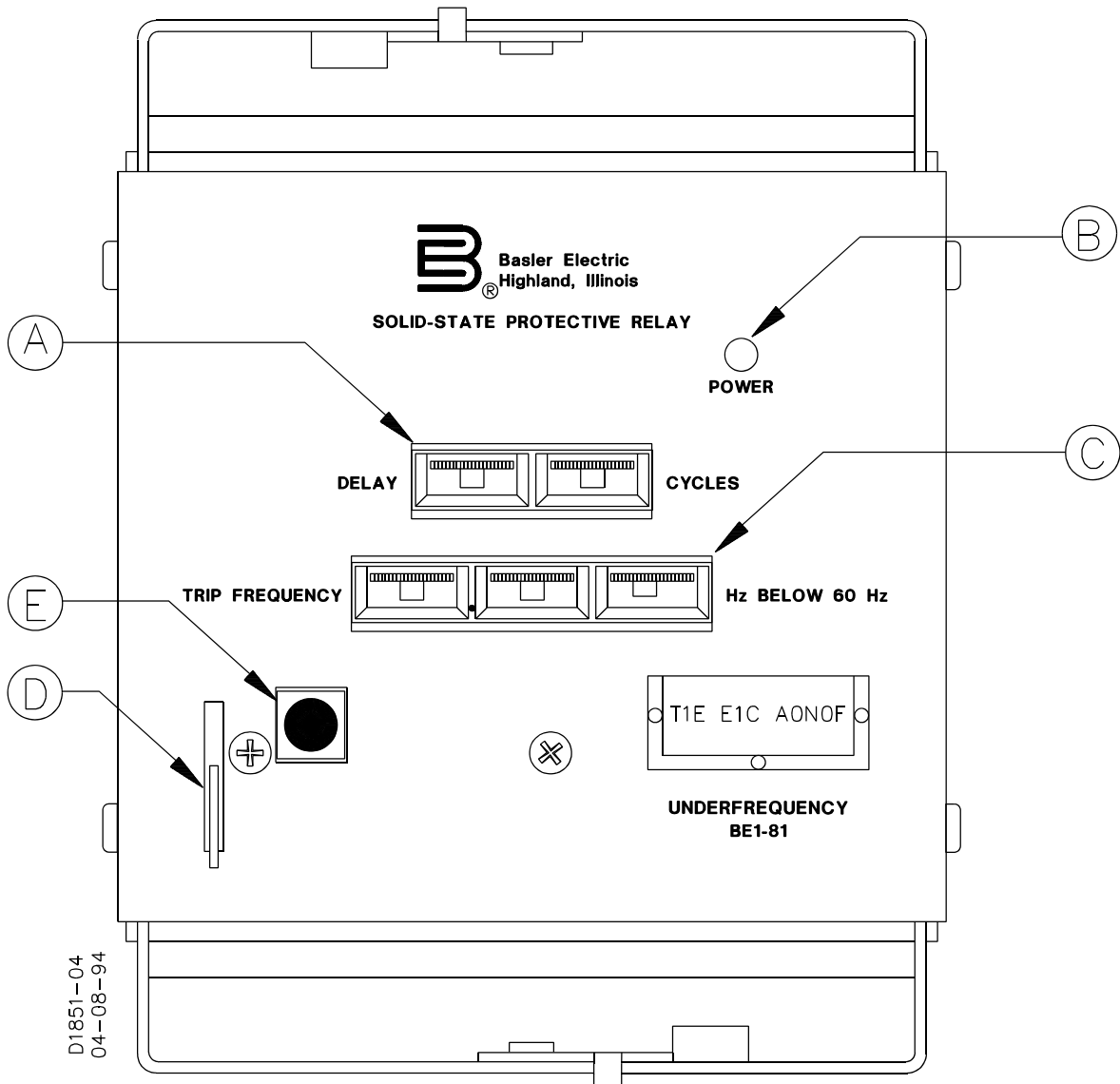
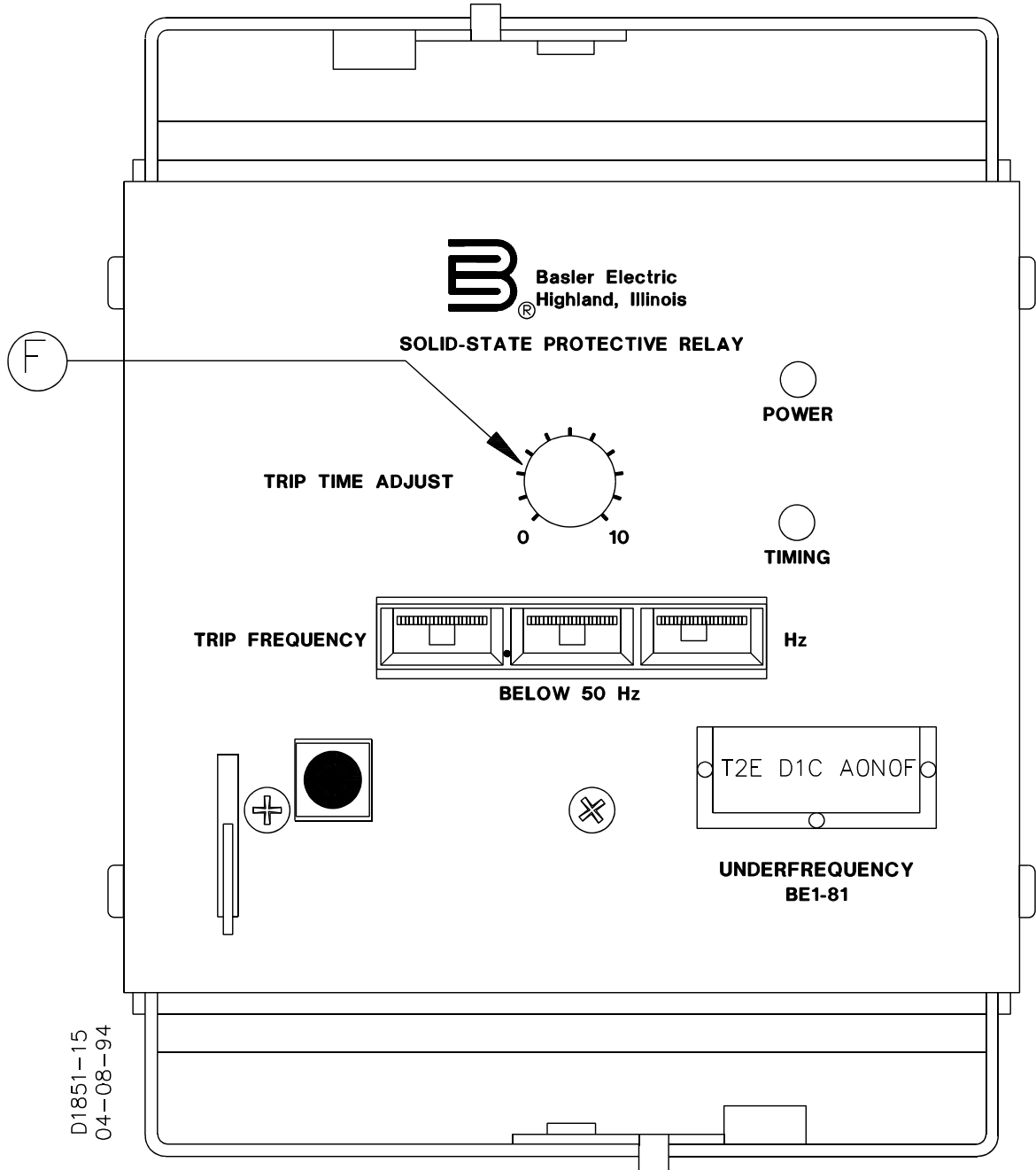

Figure 2-1. Location Of Controls And Indicators (Option E1)

BE1-81 Controls And Indicators



D1851-15
04-08-94

Figure 2-2. Location Of Controls And Indicators (Option D1)

BE1-81 Controls And Indicators

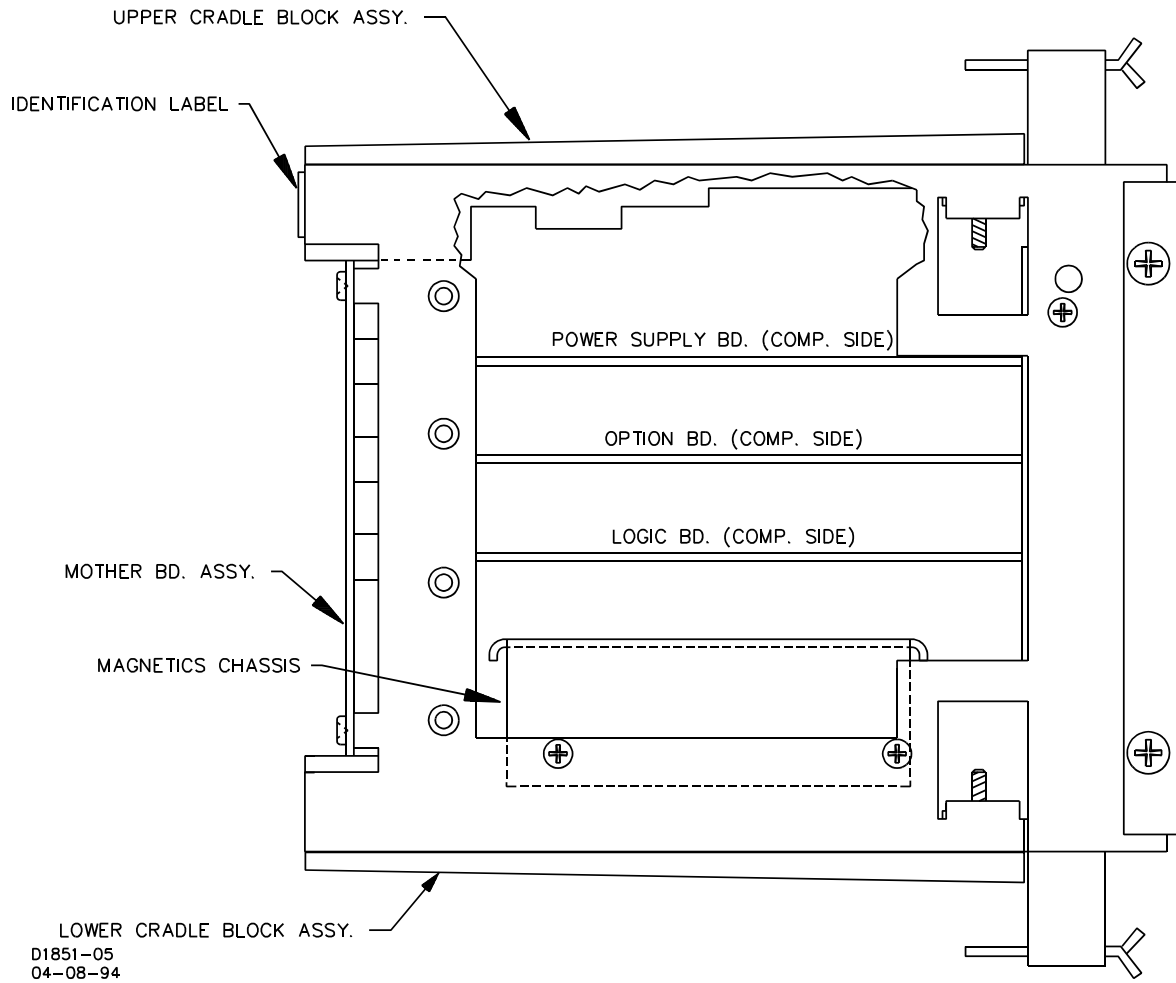

Figure 2-3. Location Of Assemblies

SECTION 3

FUNCTIONAL DESCRIPTION

FUNCTIONAL DESCRIPTION

Functional circuit descriptions provided in this section apply to both the 50 hertz and 60 hertz underfrequency relays. Refer to Figure 3-1 for a typical functional block diagram.

Sensing

When single-phase 120 Vac is applied to the sensing input, the input transformer provides the proper signal levels to the voltage inhibit and input conditioning circuits.

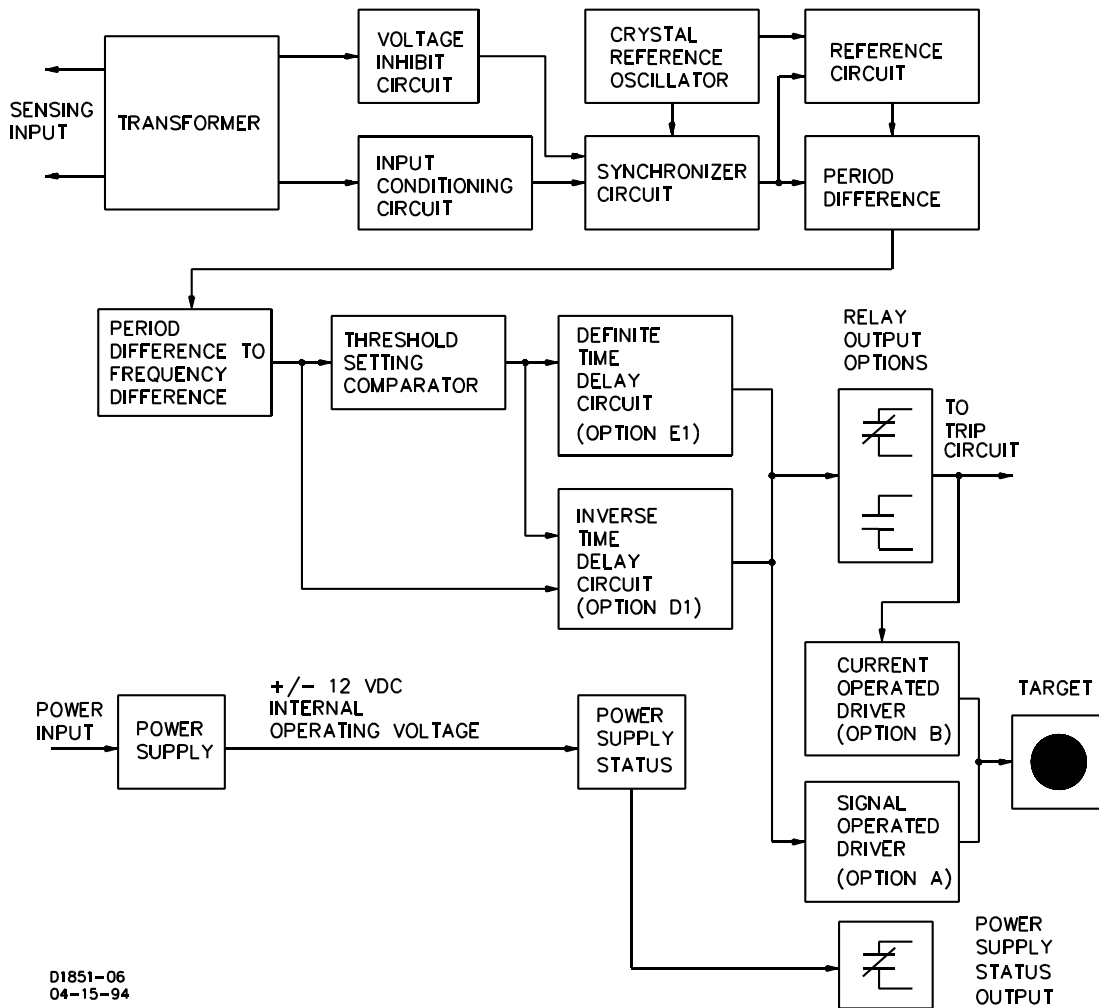

D1851-06
04-15-94

Figure 3-1. Functional Block Diagram

BE1-81 Functional Description

Power Supply

A variety of power supply options allow a wide range of external voltage inputs for relay operation. Relay operating power is developed by the low burden, flyback switching design, solid-state power supply. A nominal plus or minus twelve volts dc is delivered to the internal circuitry. Power supply inputs are not polarity sensitive. A red LED lights to indicate that the power supply is functioning properly. The LED circuit is not provided on styles receiving operating power from the sensing input.

Type W power supplies use a field adjustable link (J4) to select the appropriate input voltage (either 48 Vdc or 125 Vdc). Selection is accomplished by placing the link into the desired position (refer to Figure 3-2). This link is factory pre-set for 125 Vdc.

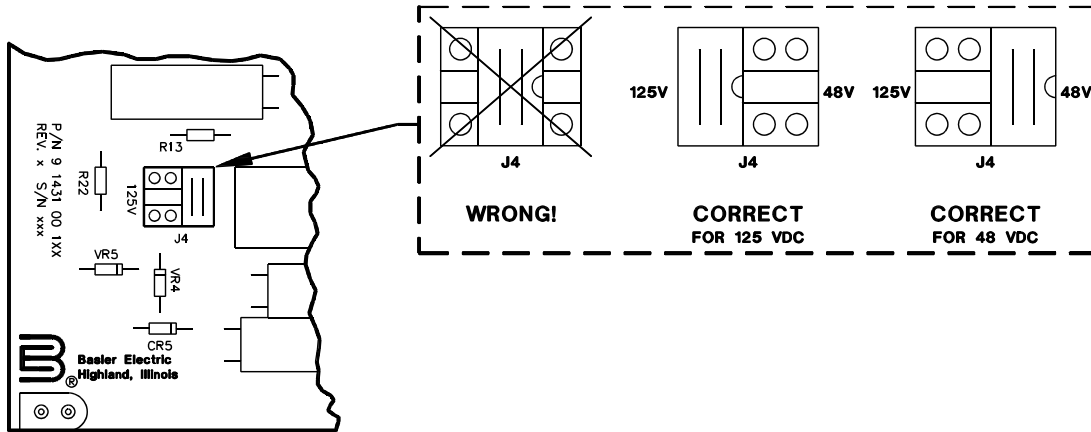

Figure 3-2. J4 Link Positioning

Power Supply Status Contacts

Power supply voltages are monitored on the mother board. Normal supply voltage causes the power supply status relay to be continually energized. However, if at any time the voltage falls below requirements, the relay drops out, and closes the normally closed contacts.

Voltage Inhibit Circuit

This circuit prevents the relay from tripping because of transient underfrequency conditions associated with equipment startup. It inhibits sensing of underfrequency conditions by the synchronizer circuit and output circuitry until the input sensing voltage is greater than 80 Vac.

Input Conditioning Circuit

The input conditioning circuit converts the sensing voltage to a squarewave whose transitions correspond to the zero crossings of the input waveform. The resulting squarewave (after further shaping) is applied to the synchronizer circuit.

Crystal Reference Oscillator

This four megahertz, crystal-controlled oscillator provides an accurate reference for the synchronizer circuit and the frequency reference circuit.

BE1-81 Functional Description

Synchronizer Circuit

This circuit synchronizes the squarewave (representative of the input waveform) with the crystal reference oscillator to generate a synchronized zero crossing pulse. The zero crossing pulse resets the system timing. Each time this zero crossing pulse occurs, a new frequency comparison is initiated.

Reference Circuit

This circuit generates a reference signal each 16.667 millisecond (60 hertz nominal system frequency) or 20.000 ms (50 hertz nominal system frequency) after a synchronized zero crossing pulse. This signal is generated by counting pulses from the reference oscillator. When the proper count is reached, an output signal is applied to the period difference circuit.

Period Difference Circuit

This circuit initiates a train of pulses beginning with the occurrence of the reference signal and ending when the synchronized zero crossing pulse occurs. The time span between these two signals is the difference in period between the sensing input waveform and the nominal system frequency. Each pulse in the pulse train represents a one microsecond difference in period.

Period Difference To Frequency Difference Circuit

This circuit converts the pulses received from the period difference circuit to one pulse for each 0.05 hertz difference from the nominal frequency. This is accomplished by a variable scale divider which compensates for the inverse relationship between period and frequency.

Threshold Setting Comparator

This circuit counts the number of pulses coming from the frequency difference circuit and compares it with the front panel control setting. When the frequency decreases beyond the difference established by the front control, an output pulse is applied to the appropriate timing circuit.

Definite Time Delay Circuit (Timing Option E1)

The definite time delay circuit counts the number of consecutive cycles of the underfrequency waveform after the threshold setting comparator output pulse occurs. When the number of underfrequency cycles equals the front panel time delay setting, a pulse is generated to the output trip circuit. It is recommended that the time delay control be set for a minimum of three cycles delay to reduce the possibility of a trip signal caused by transient-generated underfrequency conditions.

Inverse Time Delay Circuit (Timing Option D1)

The inverse time delay circuit uses the magnitude of the underfrequency condition to determine the time delay. A set of pulses, representative of the magnitude of the underfrequency condition, is applied to an RC network to generate an inverse time delay. A front panel dial permits adjustment of the time curve over the applicable 60 hertz or 50 hertz system range. An LED on the front panel indicates that the relay pickup setting has been exceeded.

Relay Output

Either normally closed or normally open relay output contacts may be selected. An optional set of auxiliary relay contacts may be specified when the relay auxiliary output option is selected. The relay contacts remain in the energized condition as long as the sensed input is below pickup.

BE1-81 Functional Description

Internally Operated Target Driver

Output from the time delay circuit is applied to this circuit to drive the target indicator. The indicator is tripped regardless of the current level in the trip circuit.

Current Operated Target Driver

This circuit will operate when a minimum dc current of 0.2 amperes flow in the output trip circuit. A special reed relay in series with the output contact provides the signal to the target indicator.

Target Indicator

The target trip indicator is visible at the front panel. The target is magnetically latched and must be reset manually after the fault condition has been cleared.

SECTION 4

INSTALLATION

GENERAL

When not shipped as part of a control or switchgear panel, the relays are shipped in sturdy cartons to prevent damage during transit. Immediately upon receipt of a relay, check the model and style number against the requisition and packing list to see that they agree. Visually inspect the relay for damage that may have occurred during shipment. If there is evidence of damage, immediately file a claim with the carrier and notify the Regional Sales Office, or contact the Sales Representative at Basler Electric, Highland, Illinois.

In the event the relay is not to be installed immediately, store the relay in its original shipping carton in a moisture and dust-free environment. When relay is to be placed in service, it is recommended that the operational test procedure (Section 5) be performed prior to installation.

RELAY OPERATING PRECAUTIONS

Before installation or operation of the relay, note the following precautions:

1. A minimum of 0.2 A in the output circuit is required to ensure operation of current operated targets.
2. Do not touch target indicator vanes. Always reset targets by use of the target reset lever.
3. The relay is a solid-state device. If a wiring insulation test is required, remove the connecting plugs and withdraw the cradle from its case.
4. When the connecting plugs are removed, the relay is disconnected from the operating circuit and will not provide system protection. Always be sure that external operating (monitored) conditions are stable before removing a relay for inspection, test, or service.
5. Be sure the relay case is hard wired to earth ground using the ground terminal on the rear of the unit. It is recommended to use a separate ground lead to the ground bus for each relay.

DIELECTRIC TEST

In accordance with IEC 255-5 and ANSI/IEEE C37.90-1978, one-minute dielectric (high potential) tests up to 1500 Vac (45-65 hertz) may be performed. This device employs decoupling capacitors to ground from terminals 3 and 4. Accordingly, a leakage current is to be expected at these terminals.

RELAY MOUNTING

Because the relay is of solid state design, it does not have to be mounted vertically. Any convenient mounting angle may be chosen. Figures 4-1 through 4-12 provide relay outline dimensions and panel drilling diagrams.

BE1-81 Installation

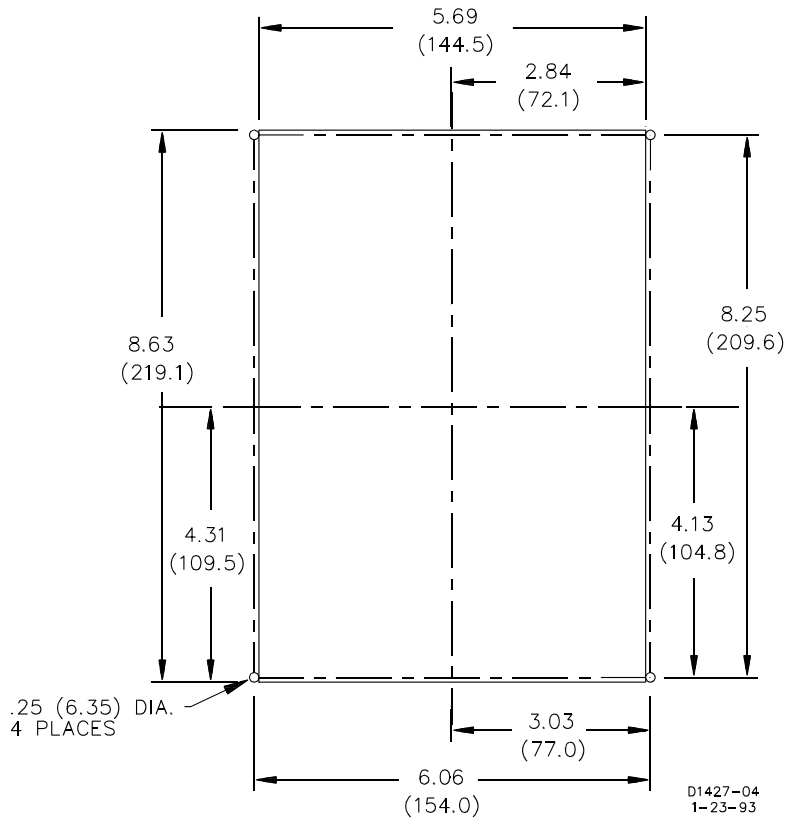

Figure 4-1. S1 Case, Panel Drilling Diagram, Semi-Flush Mounting

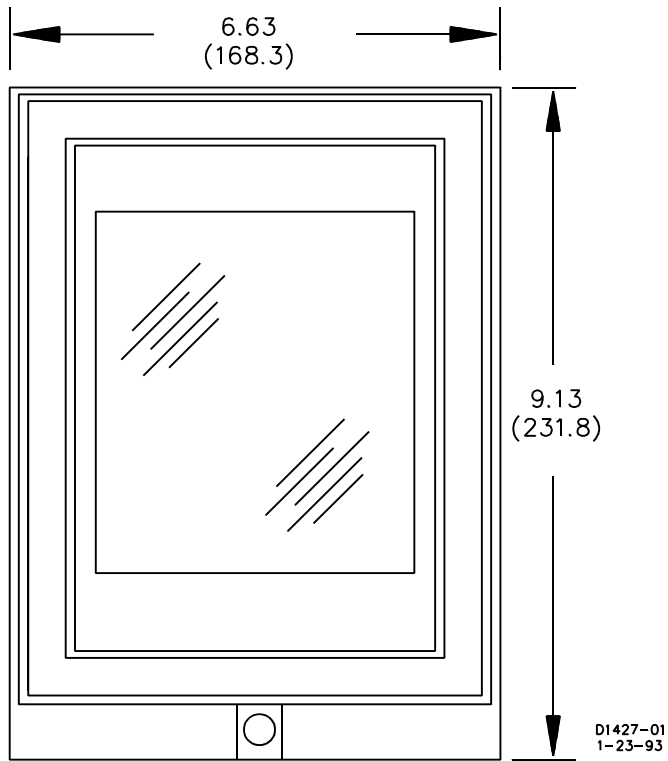

Figure 4-2. S1 Case, Outline Dimensions, Front View

BE1-81 Installation

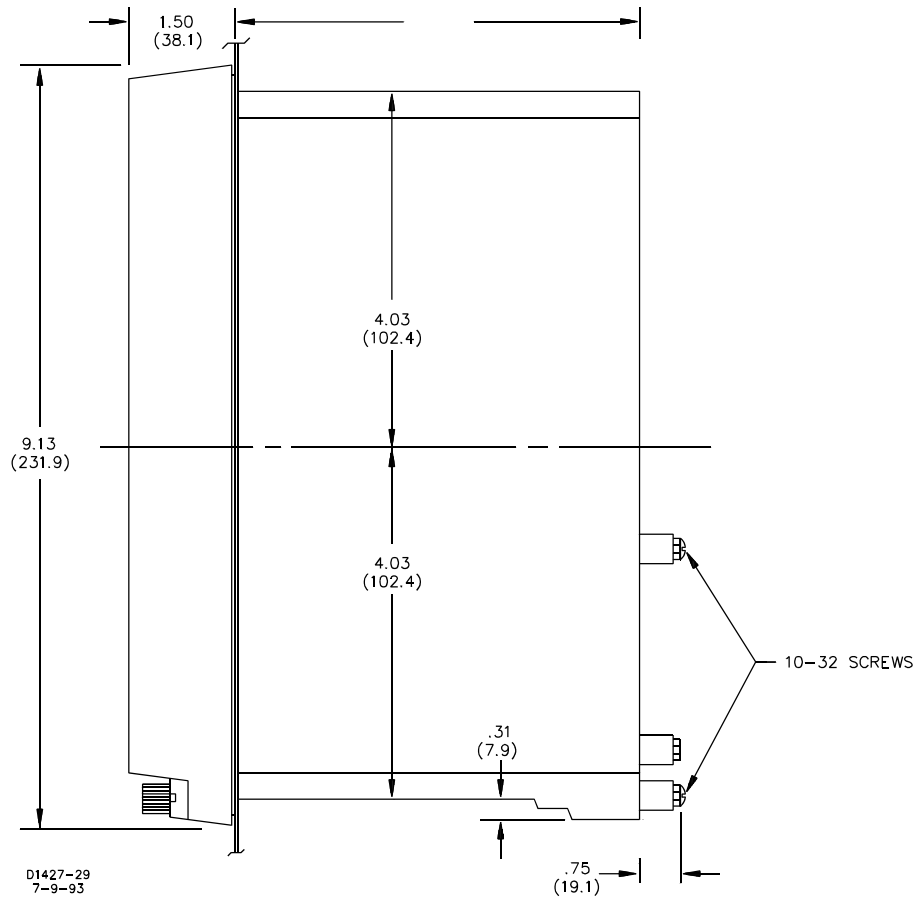

Figure 4-3. S1 Case, Single-Ended, Semi-Flush Mounting, Side View

BE1-81 Installation

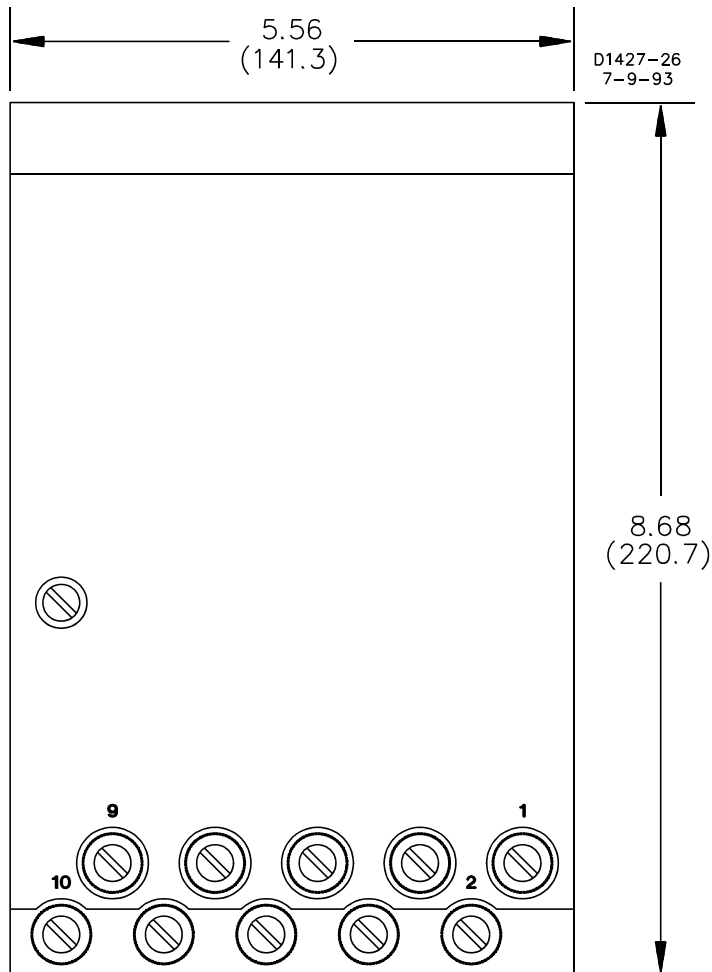

Figure 4-4. S1 Case, Single-Ended, Semi-Flush Mounting, Outline Dimensions, Rear View

BE1-81 Installation

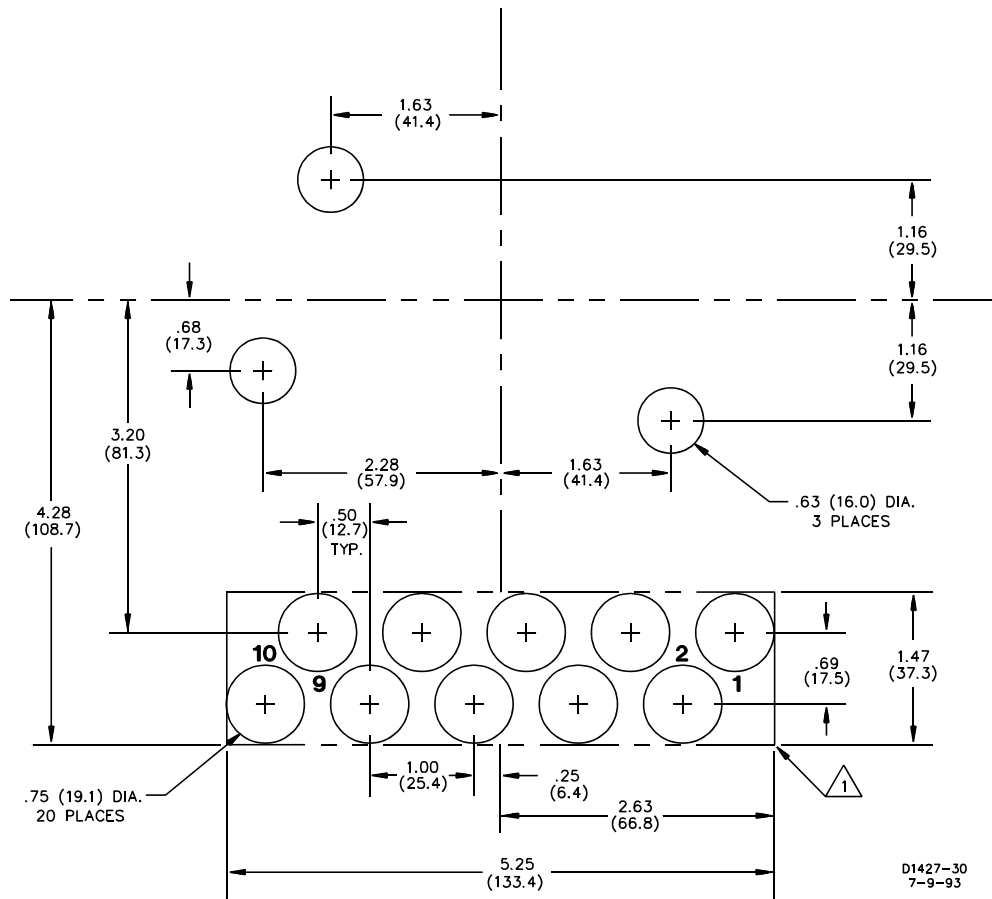

Figure 4-5. S1 Case, Single-Ended, Projection Mounting, Panel Drilling Diagram, Rear View

BE1-81 Installation

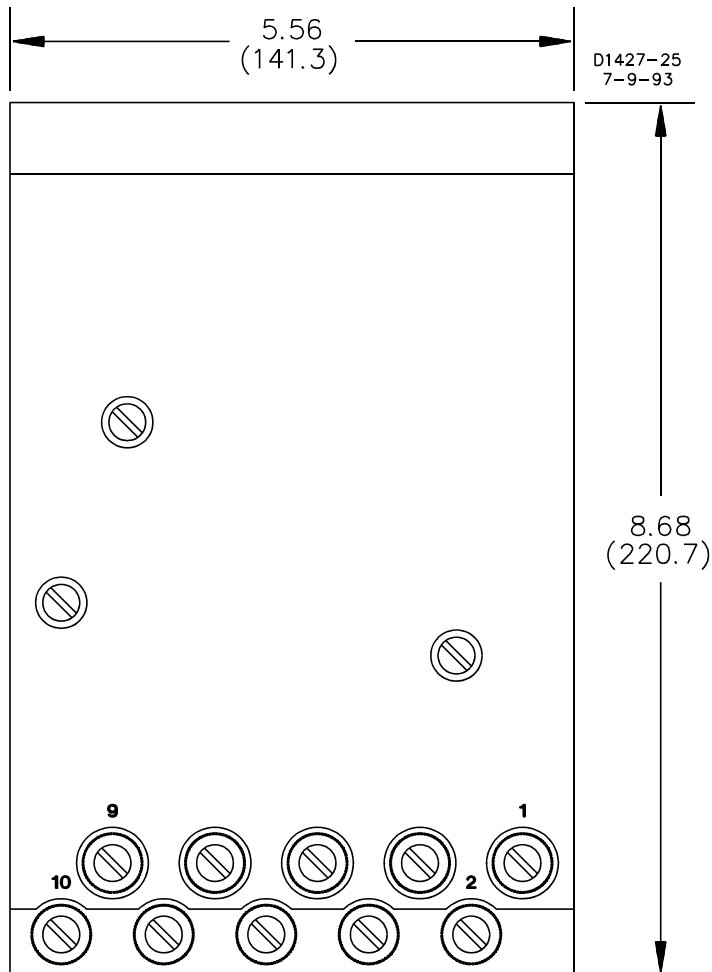

Figure 4-6. S1 Case, Single-Ended, Projection Mounting, Rear View

BE1-81 Installation

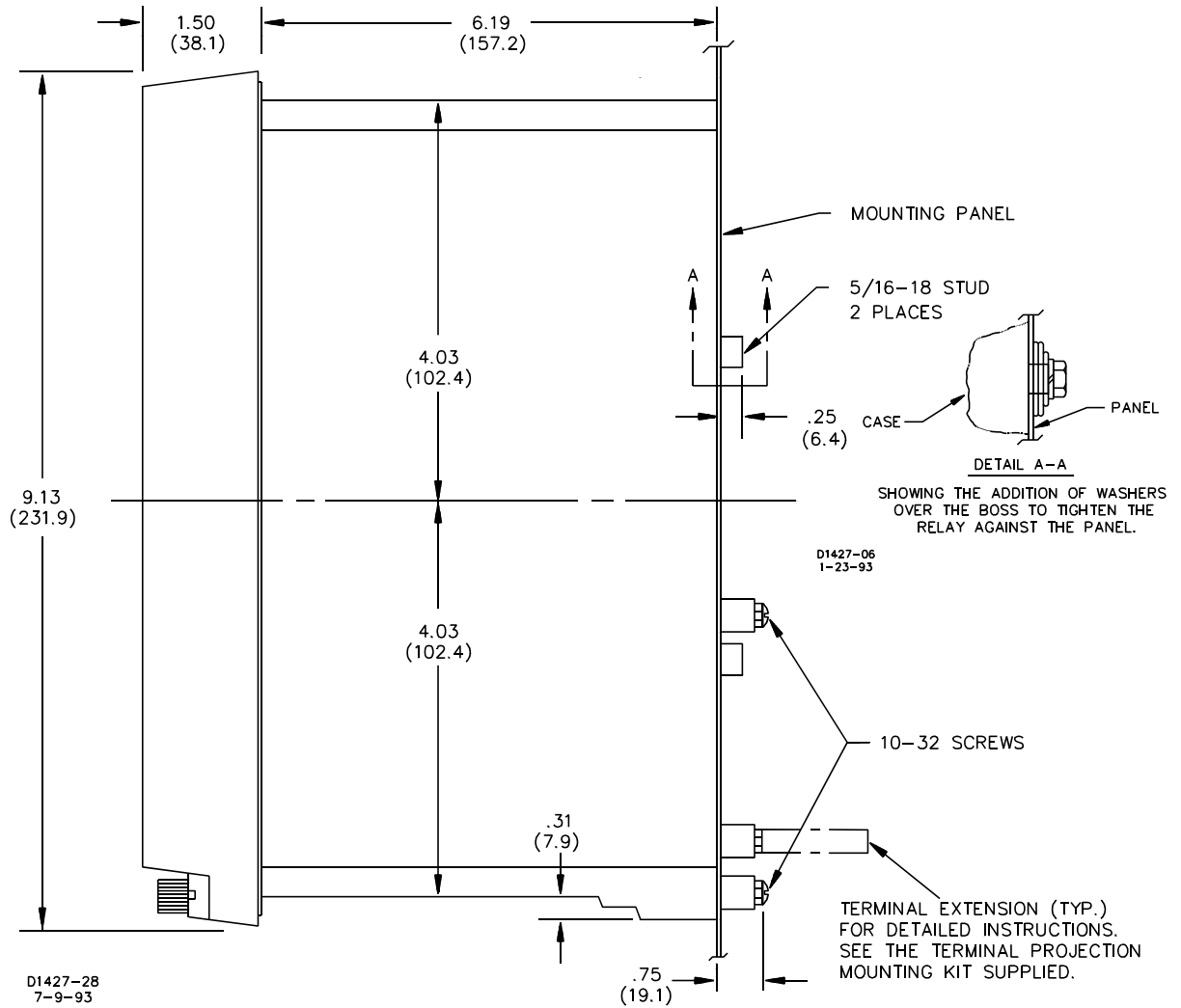

Figure 4-7. S1 Case, Single-Ended, Projection Mounting, Side View

BE1-81 Installation

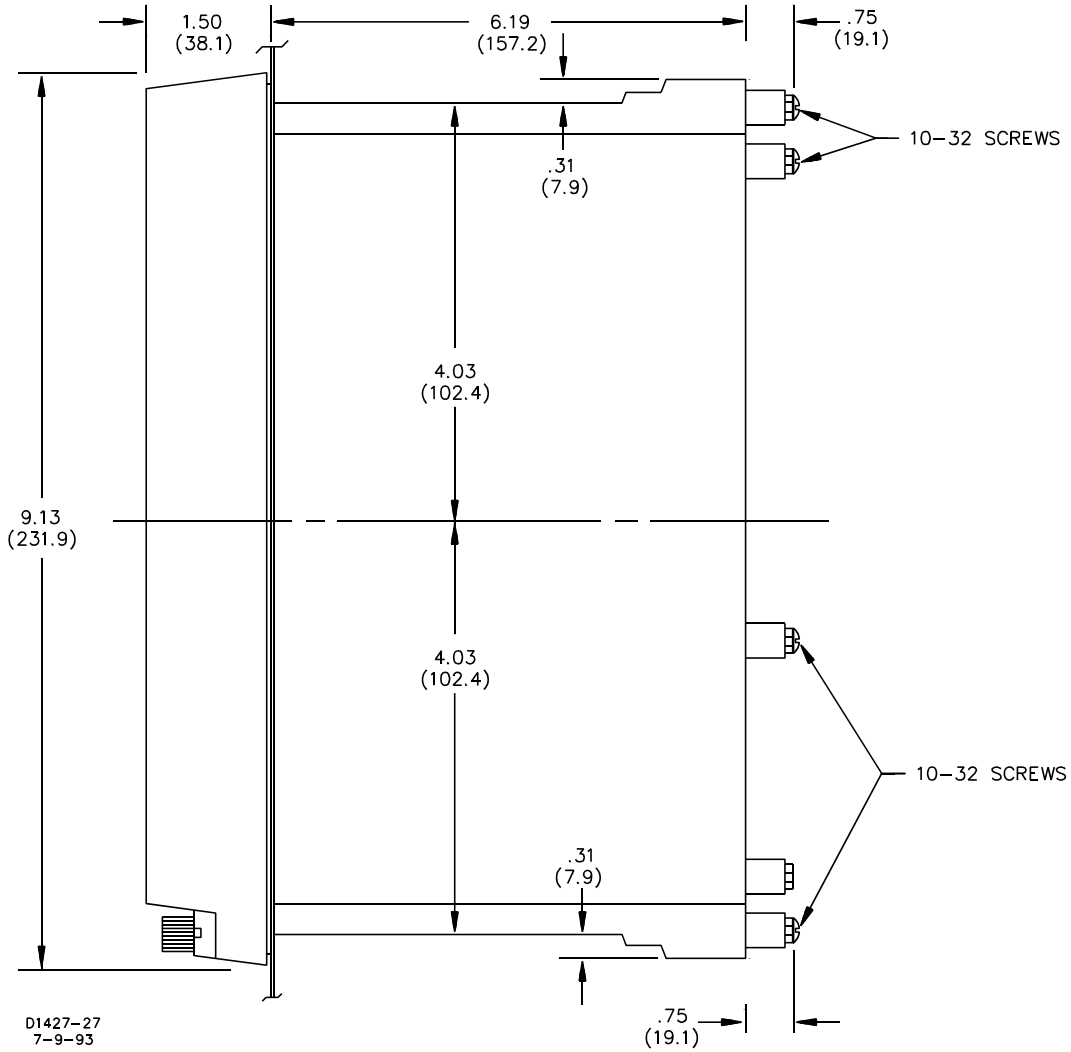

Figure 4-8. S1 Case, Double-Ended, Semi-Flush Mounting, Side View

BE1-81 Installation

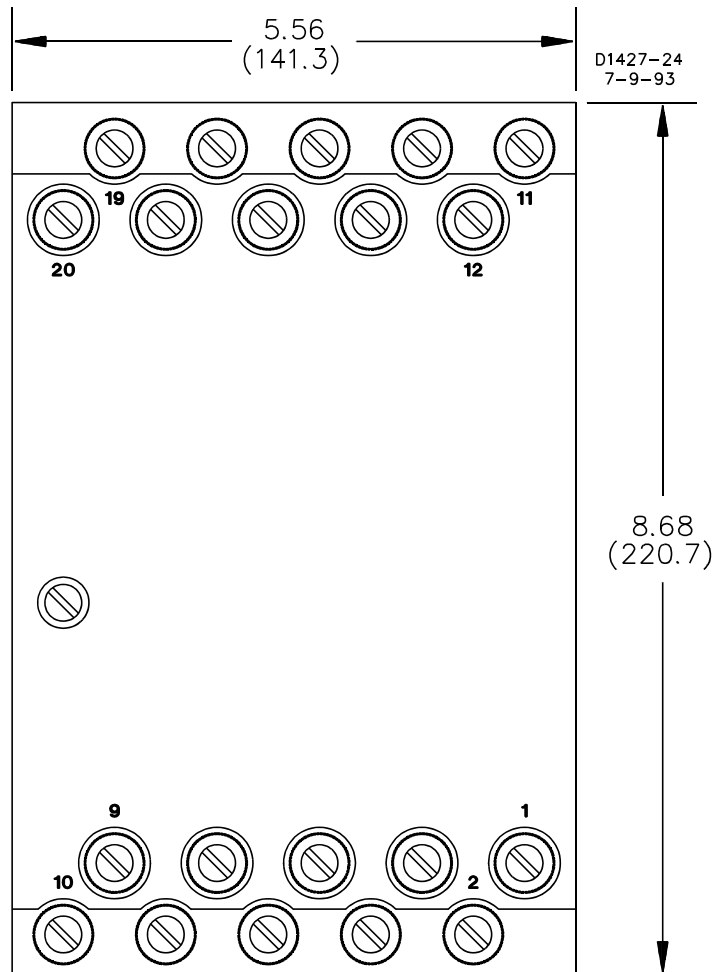

Figure 4-9. S1 Case, Double-Ended, Semi-Flush Mounting, Outline Dimensions, Rear View

BE1-81 Installation

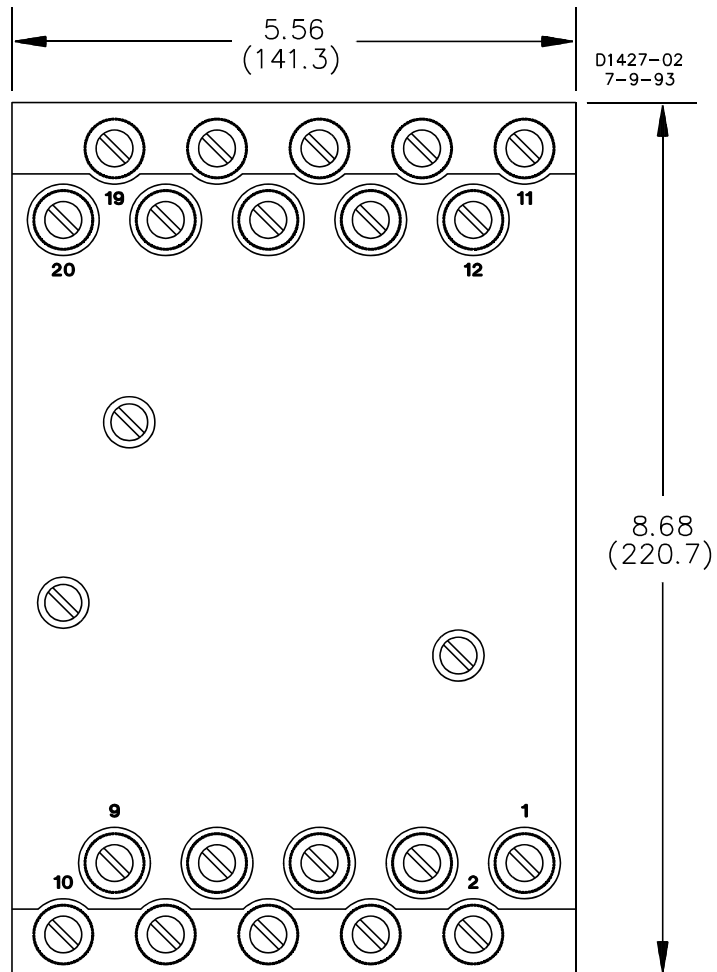

Figure 4-11. S1 Case, Double-Ended, Projection Mounting, Rear View

BE1-81 Installation

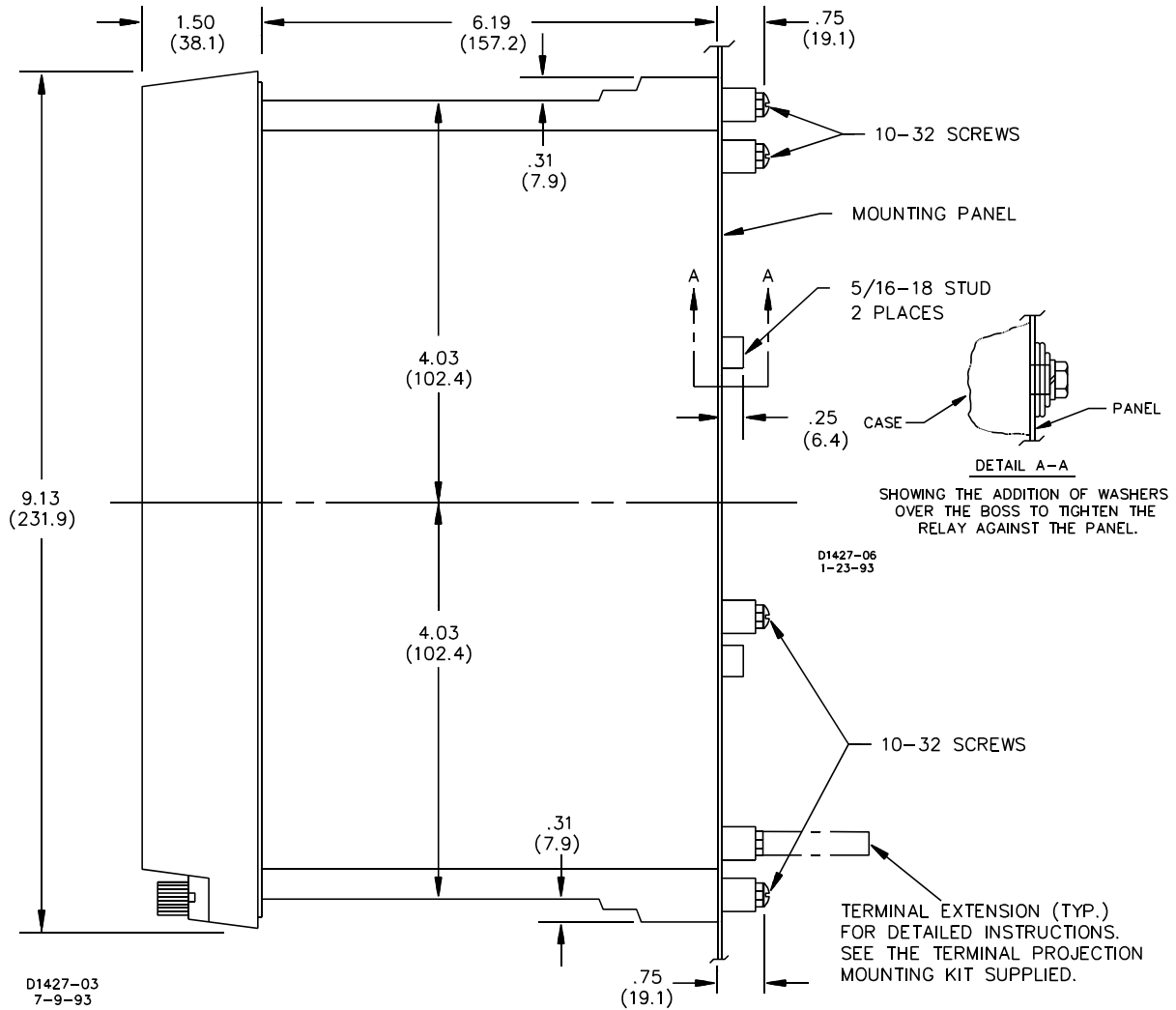

Figure 4-12. S1 Case, Double-Ended, Projection Mounting, Side View

CONNECTIONS

NOTE

Be sure the relay case is hard-wired to earth ground with no smaller than 12 AWG copper wire attached to the ground terminal on the rear of the relay case. When the relay is configured in a system with other protective devices, it is recommended to use a separate lead to the ground bus from each relay.

Incorrect wiring may result in damage to the relay. Except as noted previously, connections should be made with minimum wire size of 14 AWG. Typical AC circuit connections are shown in Figure 4-13, and typical control circuit connections in Figure 4-14. Internal connections are shown in Figures 4-15 and 4-16.

Terminals 3 and 4 are external relay power supply voltage inputs and are not polarity sensitive. When the sensing input power supply (Option 1-2) is specified, the power supply is wired directly from the sensing input terminals by the factory. Terminals 6 and 7 are the frequency sensing inputs.

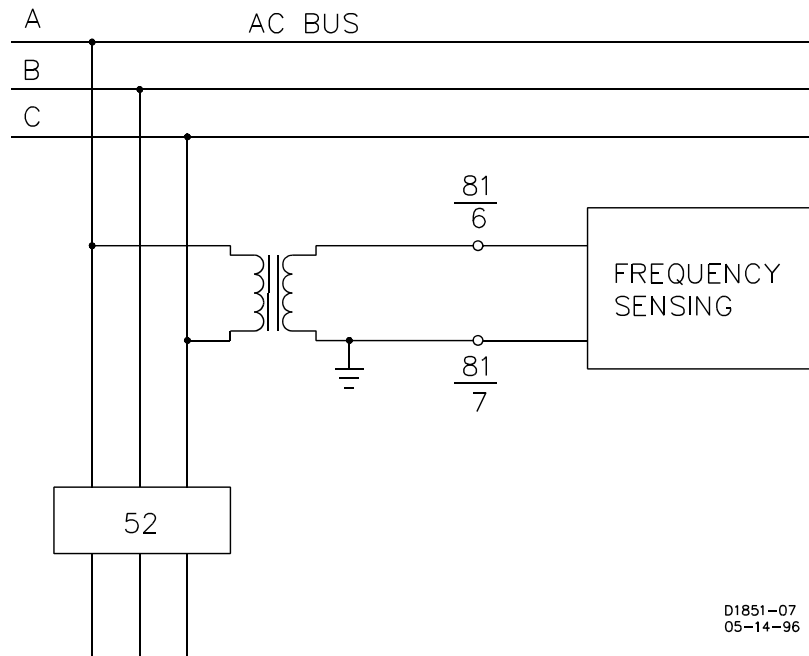

D1851-07
05-14-96

Figure 4-13. AC Sensing Input Connections

BE1-81 Installation

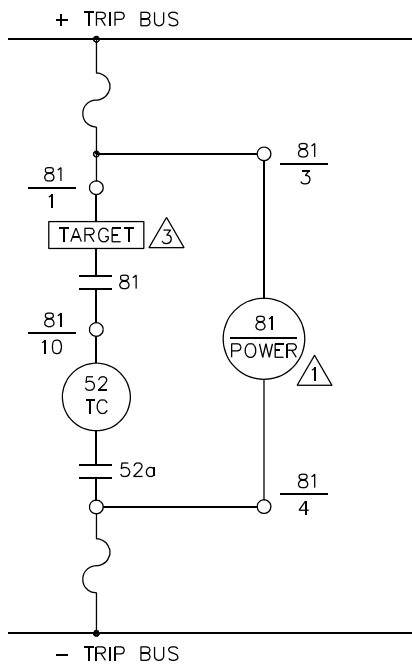

D1851-08
05-14-96

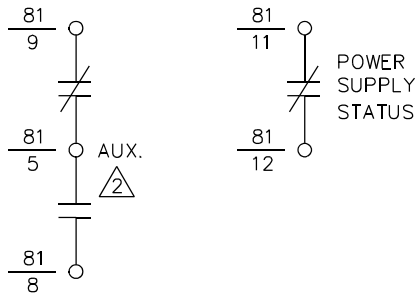

LEGEND:

- 81 DIGITAL UNDERFREQUENCY RELAY
- 52 POWER CIRCUIT BREAKER
- ~ FUSE
- TC TRIP COIL
- 52a BREAKER AUXILIARY CONTACT
- △1 EXTERNAL POWER NOT REQUIRED WHEN OPTION 1 IS 2.
- △2 OPTIONAL AUXILIARY SINGLE-POLE, DOUBLE-THROW OUTPUT SHOWN.
- △3 OPTIONAL INTERNALLY OPERATED OR CURRENT OPERATED TARGET PROVIDED AS REQUIRED BY STYLE NUMBER.

Figure 4-14. DC Control Connections

BE1-81 Installation

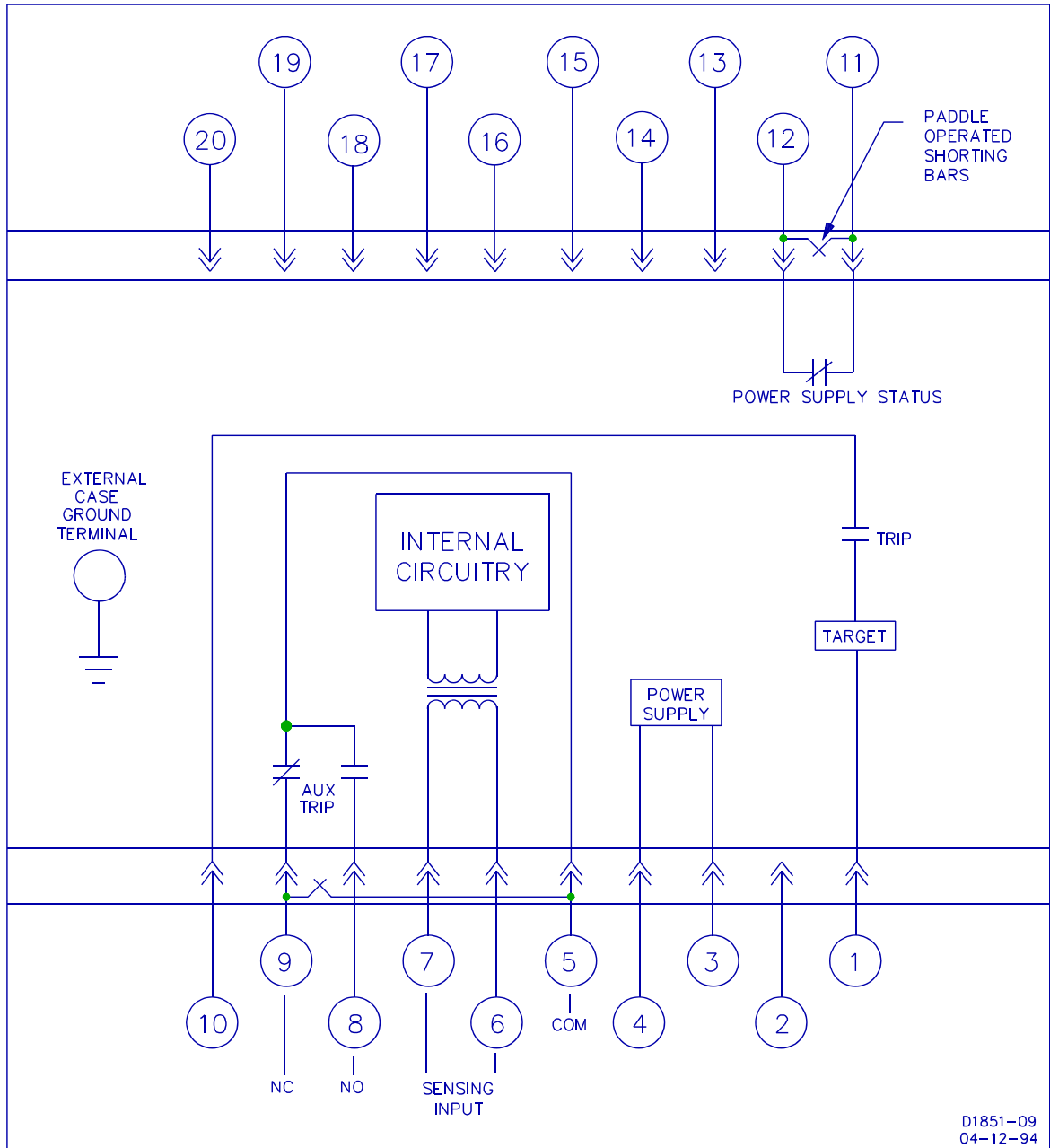

Figure 4-15. Internal Connections, Style Number T?E ?1? A0S5?

BE1-81 Installation

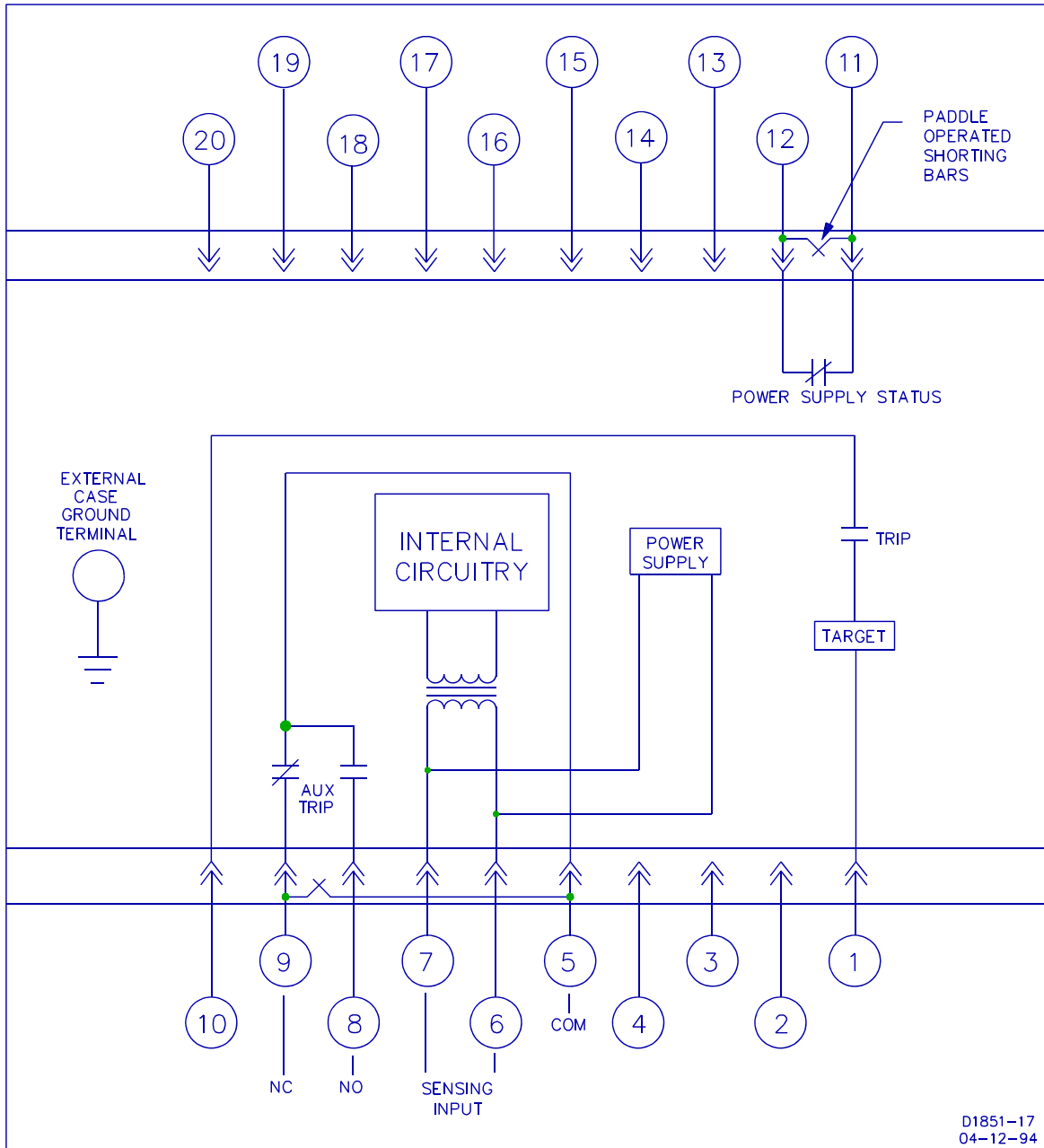

Figure 4-16. Internal Connections, Style Number T?E ?1C A2S5?

SECTION 5

TESTING

GENERAL

The test setups and procedures contained in this section are suggested for use in verifying or setting the desired pickup frequency threshold, as well as the time delay parameters, for both the definite and inverse time delay style of relay. Accuracy of the measurements in these procedures is dependent upon the stability of the test frequency sources, and the resolution of the frequency and time measuring test equipment. Functional tests performed with test equipment with an overall accuracy of less than the accuracy of the relay may be useful to the extent that they verify relay operation and approximate relay characteristics. However, tests performed under these conditions will not verify or produce calibrations any better than the test equipment accuracy; as a result, tolerances may be outside of those specified.

TEST SETUP

Figure 5-1 illustrates a test setup using a commercially available frequency test set having frequency and time generating accuracies exceeding those of the underfrequency relay.

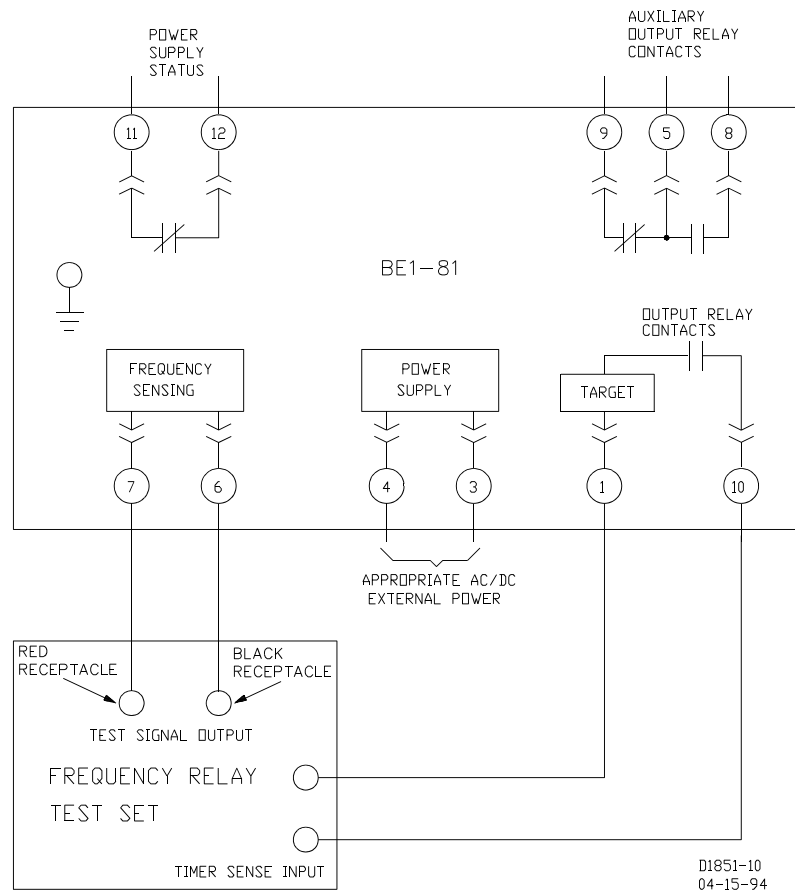

Figure 5-1. Test Setup

BE1-81 Testing

DEFINITE TIME DELAY (OPTION E1) TEST PROCEDURE

To verify/set underfrequency 50 hertz (Style T2) or 60 hertz (Style T1) relays equipped with definite time delay, perform the following steps.

- Step 1. Connect the relay as shown in Figure 5-1.
- Step 2. Apply appropriate ac or dc voltage to terminals 3 and 4 for relay styles equipped with external power supply. Apply 120 Vac, 50 hertz or 60 hertz as applicable, at terminals 6 and 7 for relay styles equipped with sensing input power supply (option 1-2).
- Step 3. Set test frequency select switch to the 50/60 hertz position as applicable.
- Step 4. Set relay front panel TRIP FREQUENCY Hz BELOW (50 or 60) thumbwheel switches for the desired underfrequency pickup point.
- Step 5. Set front panel DELAY CYCLES thumbwheel switches for a 03 cycle delay.
- Step 6. Adjust variable test frequency source to a frequency above the threshold frequency set in Step 4.
- Step 7. Set test frequency select switch to the variable position and slowly adjust variable test frequency source output down toward the pickup threshold until the relay operates. Check that target indicator, if applicable, has tripped. (Current operated targets require a minimum of 0.2 amperes dc in the trip circuit for proper operation.)
- Step 8. Read the trip frequency as indicated by the frequency source, or by an external frequency measuring device. The pickup point should be within 0.035 hertz of the selected pickup frequency set in Step 4 for the 50 hertz (T2) relays, or 0.030 hertz for the 60 hertz (T1) relays, or within the accuracy of the test set, whichever is greater. Return test frequency select switch to the 50/60 hertz position. Reset the target indicator (if supplied).
- Step 9. Repeat Steps 6 through 8 several times to verify threshold settings.

NOTE

With the trip frequency set at the desired pickup threshold, and with the test variable frequency source output adjusted to the trip frequency, verify/set the desired definite delay timing of the relay as outlined in the steps below.

- Step 10. Set test frequency select switch to the 50/60 hertz position as applicable.
- Step 11. Set front panel DELAY CYCLES thumbwheel switches for the desired delay in cycles.
- Step 12. Switch the test frequency select switch to the variable position. Verify that the relay trips and that the target indicator operates.
- Step 13. Read the delay time as indicated by the counter. The desired delay time in seconds, resulting from a sudden decrease in frequency below any pickup threshold frequency setting, should be within a 0.020 second tolerance for the 60 hertz (T1) relay or 0.030 second tolerance for the 50 hertz (T2) relay. Using the 60 hertz (T1) relay as an example, any cycles delay time setting may be calculated as follows:

$$\text{Delay time (seconds)} = \frac{\text{DELAY CYCLES Thumbwheel Setting} + 1 \text{ Cycle}}{\text{Applied Trip Frequency}}$$

BE1-81 Testing

For example:

DELAY CYCLES setting = 39
TRIP FREQUENCY hertz below setting = 3.00
Applied Trip Frequency = 57 hertz:

$$TD = \frac{39 + 1}{57}$$

$$TD = \frac{40}{57}$$

TD = 0.701 second, ±0.020 second of calculated delay time.

NOTE

The delay time accuracy should be as specified above or within the accuracy of the test equipment, whichever is greater.

Step 14. Repeat Steps 10 through 13 several times to verify relay time delay setting.

INVERSE TIME DELAY (OPTION D1 TEST PROCEDURE)

To verify/set underfrequency 50 hertz (Style T2) or 60 hertz (Style T1) relays equipped with inverse time delay, perform the following steps.

- Step 1. Connect the relay as shown in Figure 5-1.
- Step 2. Apply appropriate ac or dc voltage to terminals 3 and 4 for relay styles equipped with external power supply. Apply 120 Vac, 50 hertz or 60 hertz as applicable, at terminals 6 and 7 for relay styles equipped with sensing input power supply (option 1-2).
- Step 3. Set test frequency select switch to 50 or 60 hertz position.
- Step 4. Set relay front panel TRIP FREQUENCY Hz BELOW (50 or 60) thumbwheel switches for the desired underfrequency pickup point.
- Step 5. Set front panel TRIP TIME ADJUST control at 0 position.
- Step 6. Adjust the variable test frequency source to a frequency above the threshold frequency set in Step 4.
- Step 7. Set the test frequency select switch to the variable position and slowly adjust the test variable frequency down toward pickup threshold until the front panel TIMING LED lights, indicating that the relay pickup point has been exceeded.

NOTE

The timing required between lighting of the TIMING LED and contact closure will be long. As the frequency is decreased below the threshold setting, the time required for the output to change states is reduced.

BE1-81 Testing

- Step 8. Read the trip frequency as indicated by the frequency source, or by an external frequency measuring device. The pickup point should be within 0.035 hertz of the selected pickup frequency set in Step 4 for the 50 hertz (T2) relays or 0.030 hertz for the 60 hertz (T1) relays, or within the test set accuracy, whichever is greater. Be sure the target indicator has tripped. Return the test frequency select switch to the 50 or 60 hertz position. Reset target (if supplied).
- Step 9. Repeat Steps 6 through 8 several times to verify the relay threshold setting.
- Step 10. The steps below may be used to verify/set the inverse time delay.

NOTE

The front panel TRIP TIME ADJUST control is continuously variable and the time dial settings are therefore approximations. To set the time dial for the desired delay characteristics on or between the plotted curves for the inverse time delay, perform the following procedures.

- Step 11. Set test frequency select switch to the 50 or 60 hertz position, as applicable.
- Step 12. Set front panel TRIP TIME ADJUST control to the desired position.
- Step 13. Set front panel TRIP FREQUENCY thumbwheel switches at 1.00.
- Step 14. Adjust the variable frequency source for either 48.0 hertz (T2) or 58.0 hertz (T1) output.
- Step 15. Switch test frequency select switch to the variable position.
- Step 16. Read the trip delay time indicated by the counter. Record the delay time and compare it to the applicable delay curve shown in Section 1 to determine if the delay time is within the specified 15 percent tolerance.
- Step 17. Using the 60 hertz 0 TIME curve in Section 1 as an example, the time delay recorded in Step 16 for a 60 hertz relay should be 0.230 seconds ± 15 percent. To read this time on the curve, first subtract the input test frequency of 58.0 hertz from the nominal 60 hertz, which gives 2.0 hertz below pickup. Then subtract the front panel TRIP FREQUENCY thumbwheel setting (in this case 1.00) from the 2.0 hertz, leaving a normalized 1.0 hertz below pickup. Look along the 0 TIME curve (lower curve) until curve intersects the vertical 1.0 HERTZ BELOW PICKUP grid line. At the intersection read 0.230 seconds (± 15 percent) delay time on the TRIP TIME (SECONDS) scale.
- Step 18. Adjust TRIP TIME ADJUST control as necessary for the above tolerance.
- Step 19. Set the test frequency select switch to the 50 hertz or 60 hertz position, as applicable.
- Step 20. Adjust the variable frequency source for either a 47.0 hertz (T2) or 57.0 hertz (T1) output.
- Step 21. Switch the test frequency select switch to the variable position.
- Step 22. Read the trip time delay indicated by the counter. Record the delay time and compare it to the applicable delay curve to determine if the delay time is within the specified ± 15 percent tolerance.

BE1-81 Testing

- Step 23. Again using the 60 hertz 0 TIME curve as an example, the time delay recorded in Step 22 should be 0.135 seconds \pm 15 percent. Here again, subtract test frequency (57 hertz) from nominal (60 hertz) to arrive at hertz below pickup (3.0 hertz). Subtract front panel TRIP FREQUENCY setting (1.00) from hertz below pickup (3.0) to get normalized (2.0) hertz below pickup point. Move to the left along the 0 TIME curve until the vertical HERTZ BELOW PICKUP (2 hertz) and curve intersect. Read the corresponding delay on the TRIP TIME (SECONDS) axis.
- Step 24. Progressively decrease test variable oscillator frequency in 1 hertz steps to 46 hertz for the 50 hertz (T2), or to 56 hertz for the 60 hertz (T1). Record the resultant time delays as provided in the previous steps.
- Step 25. Using the delay times recorded in Steps 16, 22, and 24, plot these points on the appropriate time curve (50 or 60 hertz) for future reference. Connection of these points should be a curve of the same shape as the desired curve within \pm 15 percent.

This page intentionally left blank.

SECTION 6

MAINTENANCE

GENERAL

BE1-81 Digital Underfrequency Relays require no preventive maintenance other than a periodic operational test (refer to Section 5 for operational test procedure). If the relay fails to function properly, and in-house repair is contemplated, consult the Service Manual (publication number 9 1064 00 620). If factory repair is desired, contact the Customer Service Department of the Power Systems Group, Basler Electric, for a return authorization number prior to shipping.

IN-HOUSE REPAIR

In-house replacement of individual components may be difficult and should not be attempted unless appropriate equipment and qualified personnel are available.

CAUTION

Substitution of printed circuit boards or individual components does not necessarily mean the relay will operate properly. Always test the relay before placing it in operation.

If in-house repair is to be attempted, component values may be obtained from the schematics or the parts list of the Service Manual. Replacement parts may be purchased locally. The quality of replacement parts must be at least equal to that of the original components.

Where special components are involved, Basler Electric part numbers may be obtained from the number stamped on the component or assembly, the schematic, or parts list. These parts may be ordered directly from Basler Electric. When complete boards or assemblies are needed, the following information is required.

1. Relay model and style number
2. Relay serial number or date code
3. Board or assembly
 - a) Part number
 - b) Serial number
 - c) Revision letter
4. The name of the board or assembly

STORAGE

This protective relay contains aluminum electrolytic capacitors which generally have a life expectancy in excess of 10 years at storage temperatures less than 40°C. Typically, the life expectancy of the capacitor is cut in half for every 10°C rise in temperature. Storage life can be extended if, at one-year intervals, power is applied to the relay for a period of thirty minutes.

TEST PLUG

Test plugs (Basler part number 10095 or G.E. part number XLA12A1) provide a quick, easy method of testing relays without removing them from their case. Test plugs are simply substituted for the connection plugs. This provides access to the external stud connections as well as to the internal circuitry.

Test plugs consist of black and red phenolic moldings with twenty electrically separated contact fingers connected to ten coaxial binding posts. Fingers on the black side are connected to the inner binding posts (black thumb nuts) and tap into the relay internal circuitry. Fingers on the red side of the test plug are connected to the outer binding posts (red thumb nuts) and also connect to the relay case terminals.

When testing circuits connected to the bottom set of case terminals, the test plug is inserted with the numbers 1 through 10 facing up. Similarly, when using the test plug in the upper part of the relay, the numbers 11 through 20 are faceup. It is impossible, due to the construction of the test plug, to insert it with the wrong orientation.

SECTION 7

MANUAL CHANGE INFORMATION

SUMMARY AND CROSS REFERENCE GUIDE

This section contains information concerning the previous editions of the manual. The substantive changes to date are summarized in the Table 7-1.

Table 7-1. Changes

Revision	Change	ECA/Date
A	Revised the entire manual to conform with the current instructional manual style and relay configuration.	14138/04-18-96
B	Added Case Size to Section 1, <i>Specifications</i> . Corrected Table 2-1, Callout letters <i>A</i> and <i>F</i> . Changed mounting illustrations in Section 4, <i>Installation</i> , to make all illustrations more uniform in symbol size. Added ground connection to Figure 4-13, and changed the title to <i>AC Sensing Input Connections</i> . Changed Figure 4-14 title to <i>DC Control Connections</i> .	15574/05-15-96

This page intentionally left blank.

 **Basler Electric**
ROUTE 143, BOX 269
HIGHLAND, IL 62249 USA
<http://www.basler.com>, info@basler.com

PHONE +1 618-654-2341

FAX +1 618-654-2351