

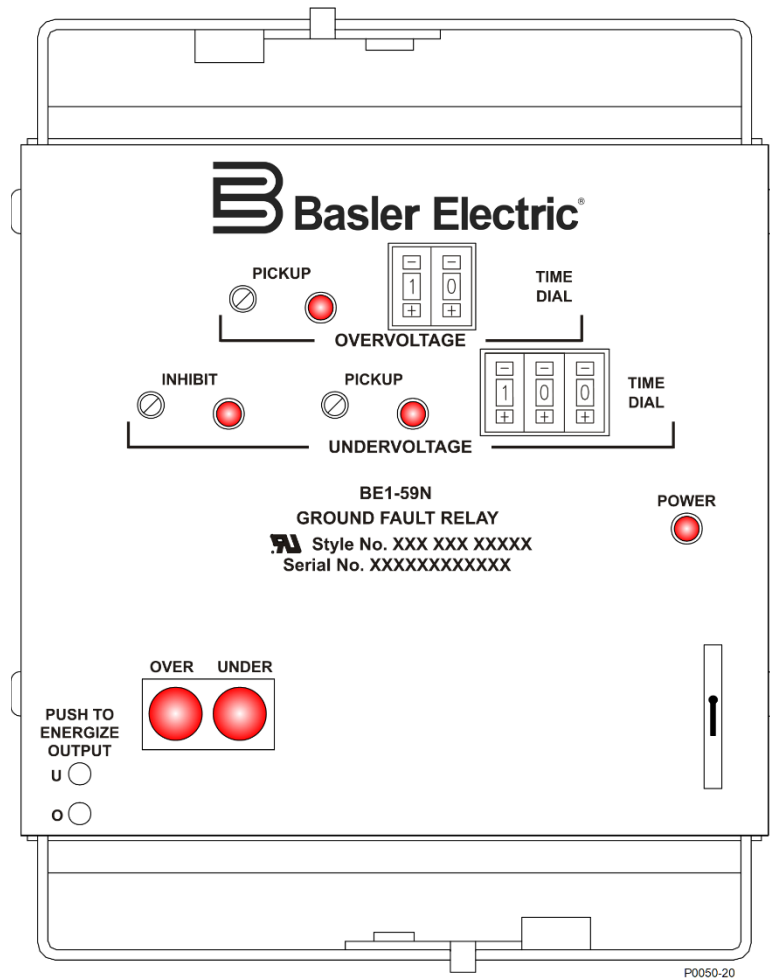



# BE1-59N

## Ground Fault Overvoltage Relay

*Instruction Manual*



 **WARNING:** California's Proposition 65 requires special warnings for products that may contain chemicals known to the state of California to cause cancer, birth defects or other reproductive harm. Please note that by posting this Proposition 65 warning, we are notifying you that one or more of the Proposition 65 listed chemicals may be present in products we sell to you. For more information about the specific chemicals found in this product, please visit <https://www.basler.com/Prop65>.

# Preface

This instruction manual provides information about the installation and operation of the BE1-59N relay. To accomplish this, the following information is provided:

- General information and specifications
- Controls and indicators
- Functional description
- Installation
- Testing

## ***Conventions Used in this Manual***

---

Important safety and procedural information is emphasized and presented in this manual through warning, caution, and note boxes. Each type is illustrated and defined as follows.

### **Warning!**

Warning boxes call attention to conditions or actions that may cause personal injury or death.

### **Caution**

Caution boxes call attention to operating conditions that may lead to equipment or property damage.

### **Note**

Note boxes emphasize important information pertaining to installation or operation.



12570 State Route 143  
Highland IL 62249-1074 USA

[www.basler.com](http://www.basler.com)  
[info@basler.com](mailto:info@basler.com)

Tel: +1 618.654.2341  
Fax: +1 618.654.2351

© 2023 by Basler Electric  
All rights reserved  
First printing: November 1986

### Warning!

READ THIS MANUAL. Read this manual before installing, operating, or maintaining this equipment. Note all warnings, cautions, and notes in this manual as well as on the product. Keep this manual with the product for reference. Only qualified personnel should install, operate, or service this system. Failure to follow warning and cautionary labels may result in personal injury or property damage. Exercise caution at all times.

Basler Electric does not assume any responsibility to compliance or noncompliance with national code, local code, or any other applicable code. This manual serves as reference material that must be well understood prior to installation, operation, or maintenance.

For terms of service relating to this product and software, see the *Commercial Terms of Products and Services* document available at [www.basler.com/terms](http://www.basler.com/terms).

This publication contains confidential information of Basler Electric Company, an Illinois corporation. It is loaned for confidential use, subject to return on request, and with the mutual understanding that it will not be used in any manner detrimental to the interests of Basler Electric Company and used strictly for the purpose intended.

It is not the intention of this manual to cover all details and variations in equipment, nor does this manual provide data for every possible contingency regarding installation or operation. The availability and design of all features and options are subject to modification without notice. Over time, improvements and revisions may be made to this publication. Before performing any of the following procedures, contact Basler Electric for the latest revision of this manual.

The English-language version of this manual serves as the only approved manual version.

# Revision History

A historical summary of the changes made to this instruction manual is provided below. Revisions are listed in reverse chronological order.

## Instruction Manual Revision History

Manual Revision and Date	Change
P, Jun 2023	<ul style="list-style-type: none"> <li>Minor formatting corrections and text edits.</li> </ul>
O	<ul style="list-style-type: none"> <li>This revision letter not used.</li> </ul>
N, Jul 2022	<ul style="list-style-type: none"> <li>Added a note about EMI suppression in the Installation section.</li> </ul>
M, Dec 2021	<ul style="list-style-type: none"> <li>Adjusted style chart to reflect obsolescence of current-operated targets.</li> <li>Corrected Locator D description in Table 2-1.</li> <li>Updated manual to new style.</li> </ul>
L, Jan 2019	<ul style="list-style-type: none"> <li>Added California Proposition 65 warning.</li> <li>Added three ground points in Figure 4-9.</li> <li>Corrected Steps 8 and 9 in Section 5, <i>Testing</i>.</li> </ul>
K, Oct 2013	<ul style="list-style-type: none"> <li>Added instantaneous timing characteristic for 50-Hz relays.</li> </ul>
J, Jan 2013	<ul style="list-style-type: none"> <li>Updated case and cover drawings in Section 4.</li> </ul>
I	<ul style="list-style-type: none"> <li>This revision letter not used.</li> </ul>
H, Apr 2009	<ul style="list-style-type: none"> <li>Corrected misalignment of data columns below Figure 1-4.</li> <li>Updated Storage statement in Section 4, <i>Installation</i>.</li> </ul>
G, Sep 2007	<ul style="list-style-type: none"> <li>Updated Output Contact ratings in Section 1.</li> <li>Moved content of Section 6, <i>Manual Change Information</i> to Manual <i>Introduction</i>.</li> <li>Updated front panel illustrations to show laser graphics.</li> <li>Moved Testing content of Section 4, <i>Installation</i> to Section 5, <i>Testing</i>.</li> <li>Added manual part number and revision to all footers.</li> <li>Updated power supply burden data in Section 1.</li> <li>Updated Target Indicator description in Section 3.</li> <li>Added GOST-R to Section 1, General Information.</li> </ul>
F, Apr 2002	<ul style="list-style-type: none"> <li>Revised the power supply information in Sections 1 and 3.</li> </ul>
E, Dec 2001	<ul style="list-style-type: none"> <li>Updated power supply information in the style chart on page 1-3 and in the example on page 1-2.</li> <li>Updated pickup voltage ranges and accuracies on page 1-4.</li> <li>Updated power supply description paragraphs on page 3-3.</li> <li>Updated unit case covers on pages 4-9 and 4-10.</li> <li>Updated drawings of front cover to show the new pushbutton switches instead of the thumbwheel switches.</li> </ul>
D, Jan 1993	<ul style="list-style-type: none"> <li>New style chart (new option 1-2 and expanded option 1-1).</li> <li>Restructured the entire manual to conform to manual updates.</li> </ul>
C	<ul style="list-style-type: none"> <li>Accuracy specification for the Definite Timing Characteristic was clarified and upgraded on page 1-4.</li> <li>Output contact specifications were updated.</li> </ul>
B	<ul style="list-style-type: none"> <li>Incorporated new timing option F7 in the manual.</li> <li>K was clarified for the various options on page 2-3.</li> </ul>

---

<b>Manual Revision and Date</b>	<b>Change</b>
A	<ul style="list-style-type: none"><li>• Accuracy specification for the Inverse Timing Characteristic was clarified and upgraded on page 1-4.</li></ul>
—, Nov 1986	<ul style="list-style-type: none"><li>• Initial release</li></ul>

# Contents

General Information .....	1-1
Controls and Indicators .....	2-1
Functional Description.....	3-1
Installation.....	4-1
Testing.....	5-1



# 1 • General Information

The available fault current for single-phase-to-ground faults is very limited for ungrounded systems and systems, which are grounded through a high resistance. This current limiting reduces the possibility of extensive equipment damage, and eliminates the need for a neutral breaker by reducing the fault current below the level required to sustain an arc. However, it remains important to detect and isolate single-phase-to-ground faults in order to prevent their evolution into more dangerous faults such as phase-to-phase-to-ground and three-phase-to-ground faults. Sensitive voltage relays can be used to detect ground faults where the fault current is very small. The BE1-59N Ground Fault Overvoltage Relay is especially suited to this task.

## Application

### High Resistance Grounding

A common method of grounding an ac generator is to connect a distribution transformer between the neutral of the generator and the station ground. The distribution transformer's primary voltage rating is equal to, or greater than, the generators rated line-to-neutral voltage. The distribution transformer secondary is rated at 200/240 Vac or 100/120 Vac, and a resistor is connected across the secondary winding. When reflected through the transformer, the resistor is effectively a high resistance.

$$R_p = R_s \times N^2$$

Where:  $R_p$  is the effective primary resistance

$R_s$  is the actual value of the secondary resistor

$N$  is the turns ratio of the distribution transformer

To determine resistor sizing:

- Determine the thermal limit  $P$  (in watts) of the voltage transformers.
- Use  $\frac{(V_{sec})^2}{V_{pri}} = R$  to determine resistance in ohms, where  $V_{sec} = 120 \times 3 = 360V$ . This assumes a 120V VT secondary in a worst-case condition.
- Size the watt rating of the resistor for 1/3 of the VT thermal limit to keep the resistor from excessive heating. A smaller watt rating can be used if tripping for a ground condition.

Available single-phase-to-ground fault current at the generator terminals is greatly reduced by the high effective resistance of the distribution transformer and secondary resistor. The distribution transformer provides isolation for the protection scheme and reduces the voltage to a convenient level.

The BE1-59N Ground Fault Overvoltage Relay is connected across the secondary resistor to detect the increase in voltage across the distribution transformer caused by a ground fault in the generator stator windings. A ground fault at the generator terminals will result in rated line-to-neutral voltage across the transformer primary, while ground faults near the neutral will result in lower voltages. The overvoltage relay setpoint must be higher than any neutral voltage caused by normal unbalances in order to avoid nuisance trips. This will allow a certain percentage of the stator windings to go unprotected by the overvoltage relay. The overvoltage relay function typically protects 90 to 95% of the generator stator windings.

The BE1-59N Ground Fault Overvoltage Relay monitors the fundamental frequency (50 or 60 Hz) voltage, which accompanies a ground fault, but is insensitive to the third harmonic voltage present during normal operation. One hundred percent protection of the generator stator windings is obtainable with the optional overlapping undervoltage element. The under voltage element is tuned to the third harmonic voltage which is present in the generator neutral under normal conditions. The undervoltage element detects the reduction of the normal third harmonic voltage, which accompanies a ground fault near the neutral point of the generator.

An undervoltage inhibit feature is included with the third harmonic undervoltage element. This feature supervises the operation of the ground fault relay to prevent operation during startup and shutdown by monitoring the generator terminal voltage.

### Ungrounded Systems

The BE1-59N Ground Fault Overvoltage Relay is used to detect ground faults on ungrounded three-phase-three-wire systems. The relay is connected as shown in Figure 1-1. A set of voltage transformers are wired with a grounded wye primary and a broken delta secondary. The BE1-59N is connected across the broken delta. It is often necessary to connect a resistor across the broken delta to avoid ferroresonance.

Grounded wye/broken delta voltage transformers act as a zero sequence filters by summing the three phase voltages. Under normal conditions, this sum is zero. When a ground fault occurs, the BE1-59N Ground Fault Overvoltage Relay will detect the presence of the secondary zero sequence voltage ( $3V_0$ ).

The BE1-59N Ground Fault Overvoltage Relay greatly reduces the risk of equipment damage by detecting and isolating the first ground on an ungrounded system.

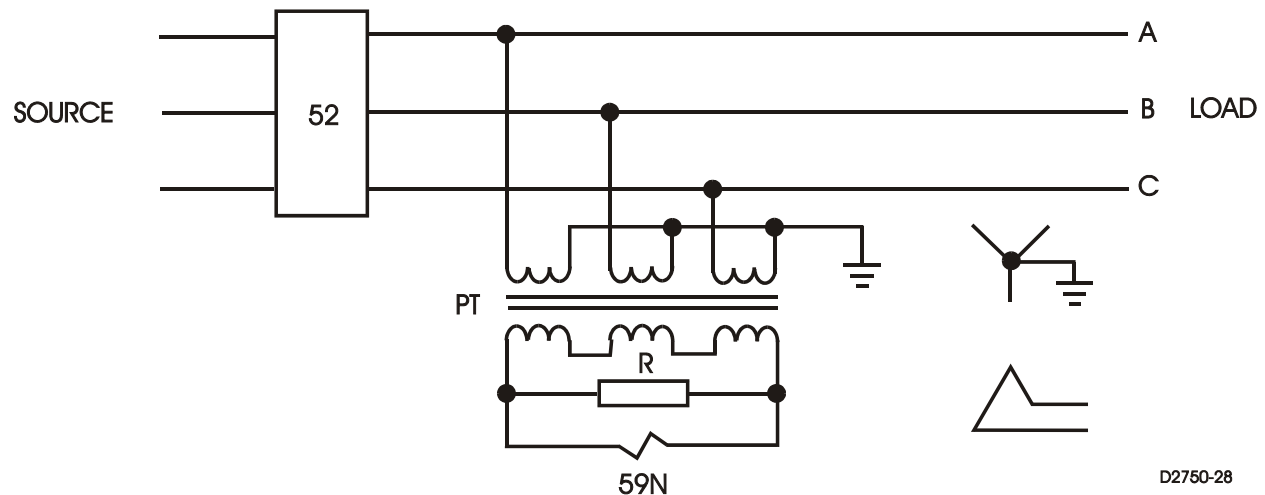

Figure 1-1. Ungrounded 3-Phase, 3-Wire System

### Model and Style Number

BE1-59N electrical characteristics and operational features are defined by a combination of letters and numbers that make up the style number. Model number BE1-59N designates the relay as a Basler Electric Ground Fault Overvoltage Protective Relay. The model number, together with the style number, describes the options included in a specific device and appears on the front panel, draw-out cradle, and inside the case assembly.

The style number identification chart for the BE1-59N relay is illustrated in Figure 1-2.

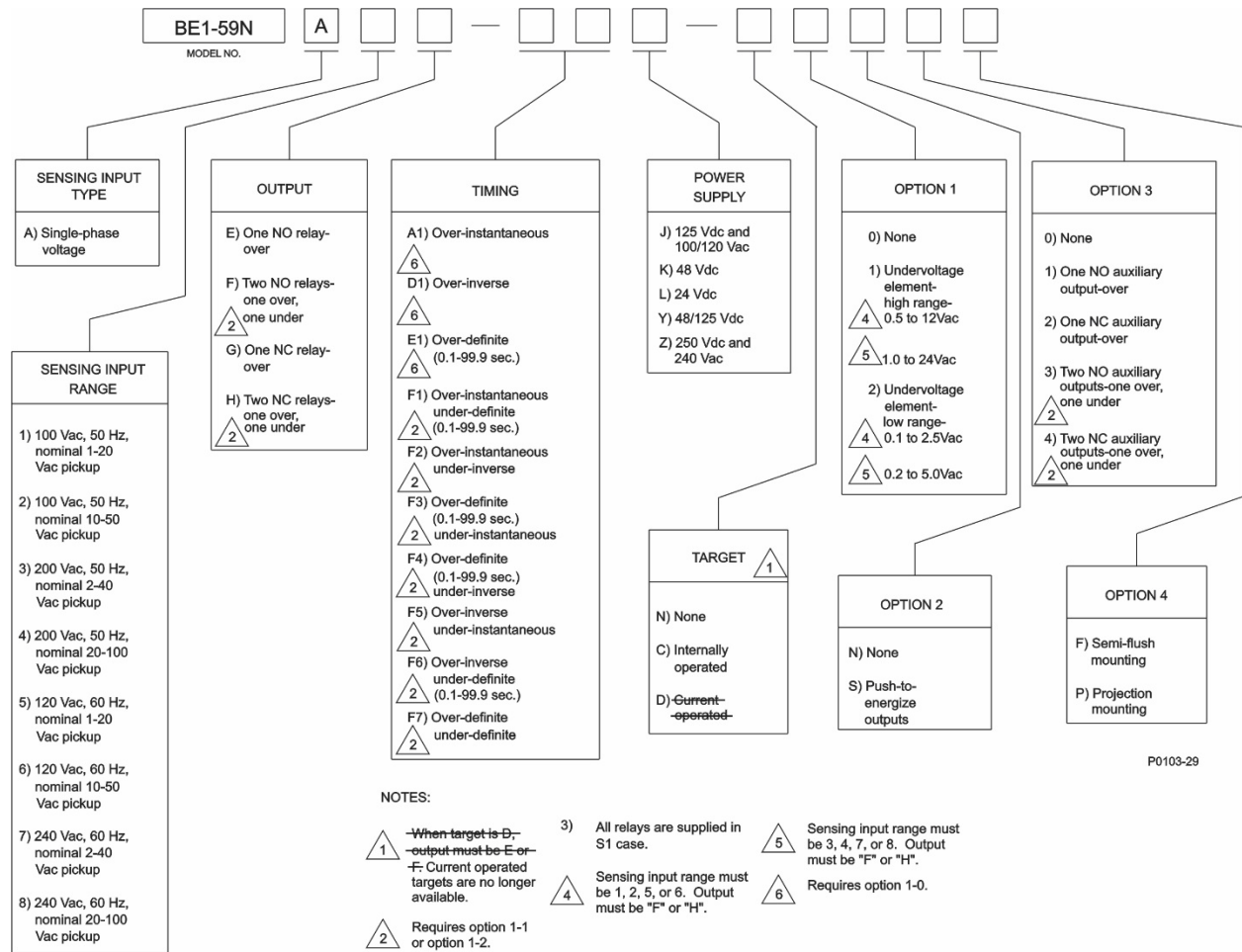

Figure 1-2. BE1-59N Style Identification Chart

**Style Number Example**

If a BE1-59N relay has a style number of **A5F-F6J-C2S3F**, the relay has the following features:

- A** -----Single-phase voltage sensing input
- 5** -----120 Vac, 60 Hz nominal sensing voltage input with 1 to 20 Vac pickup range
- F** -----Two output relays with normally open (NO) contacts (one overvoltage and one undervoltage)
- F6**-----Inverse time delay for overvoltage and definite time delay for undervoltage
- J** -----Relay control power is 125 Vdc or 120 Vac, nominal
- C** -----Two internally operated target indicators (one per function)
- 2** -----Undervoltage element range 0.1 to 2.5 Vac (low range with sensing input 5)
- S** -----Push-to-energize outputs
- 3** -----Two normally-open auxiliary output relays (one per function)
- F** -----Semi-flush mounting case

## Specifications

---

BE1-59N electrical and physical specifications are listed in the following paragraphs.

### Voltage Sensing Inputs

Maximum continuous rating: 360 Vac for 100/120 Vac input, 480 Vac for 200/240 Vac input, with a maximum burden of 2 VA for each input.

### Undervoltage Sensing Input Range

High Range: 0.5 to 12 Vac (sensing input range 1, 2, 5, or 6) or 1.0 to 24 Vac (sensing input range 3, 4, 7, or 8).

Low Range: 0.1 to 2.5 Vac (sensing input range 1, 2, 5, or 6) or 0.2 to 5.0 Vac (sensing input range 3, 4, 7, or 8).

#### Pickup Accuracy

1 to 24 Vac range:  $\pm 2\%$  or 20 millivolts

All other ranges:  $\pm 2\%$  or 10 millivolts

### Overvoltage Sensing Input Range

Ranges selectable by unit type for 50 or 60 Hz operation: 1 to 20 Vac, 10 to 50 Vac, 2 to 40 Vac, 20 to 100 Vac.

#### Pickup Accuracy

120 Vac (sensing input range 1, 2, 5, or 6):  $\pm 2\%$  or 100 millivolts, whichever is greater

240 Vac (sensing input range 3, 4, 7, or 8):  $\pm 2\%$  or 200 millivolts, whichever is greater

### Dropout

98% of pickup within 7 cycles.

### Timing Characteristics

Instantaneous: Less than 70 milliseconds (60-Hz relays) or less than 84 milliseconds (50-Hz relays) for a voltage level that exceeds the pickup setting by 5% or 1 volt, whichever is greater

Definite: Adjustable from 00.1 to 99.9 seconds, in steps of 0.1 seconds. Accuracy is within 2% or 100 milliseconds, whichever is greater. (A setting of 00.0 provides instantaneous timing.)

Inverse: Response time decreases as the difference between the monitored voltage and the setpoint increases. The inverse time characteristics switch is adjustable from 01 to 99 in 01 increments. Each position corresponds to a specific curve except 00, which is instantaneous.

Accuracy is within  $\pm 5\%$  or 25 milliseconds (whichever is greater) of the indicated time for any combination of the time dial and within  $\pm 2\%$  of the voltage magnitude or 100 millivolts (for the 120 Vac sensing range) or 200 millivolts (for the 240 Vac sensing range) (whichever is greater) from the actual pickup value. Inverse time is repeatable within  $\pm 2\%$  or 25 milliseconds (whichever is greater) for any time dial or pickup setting. The characteristic curves are defined in Figures 1-3 and 1-4.

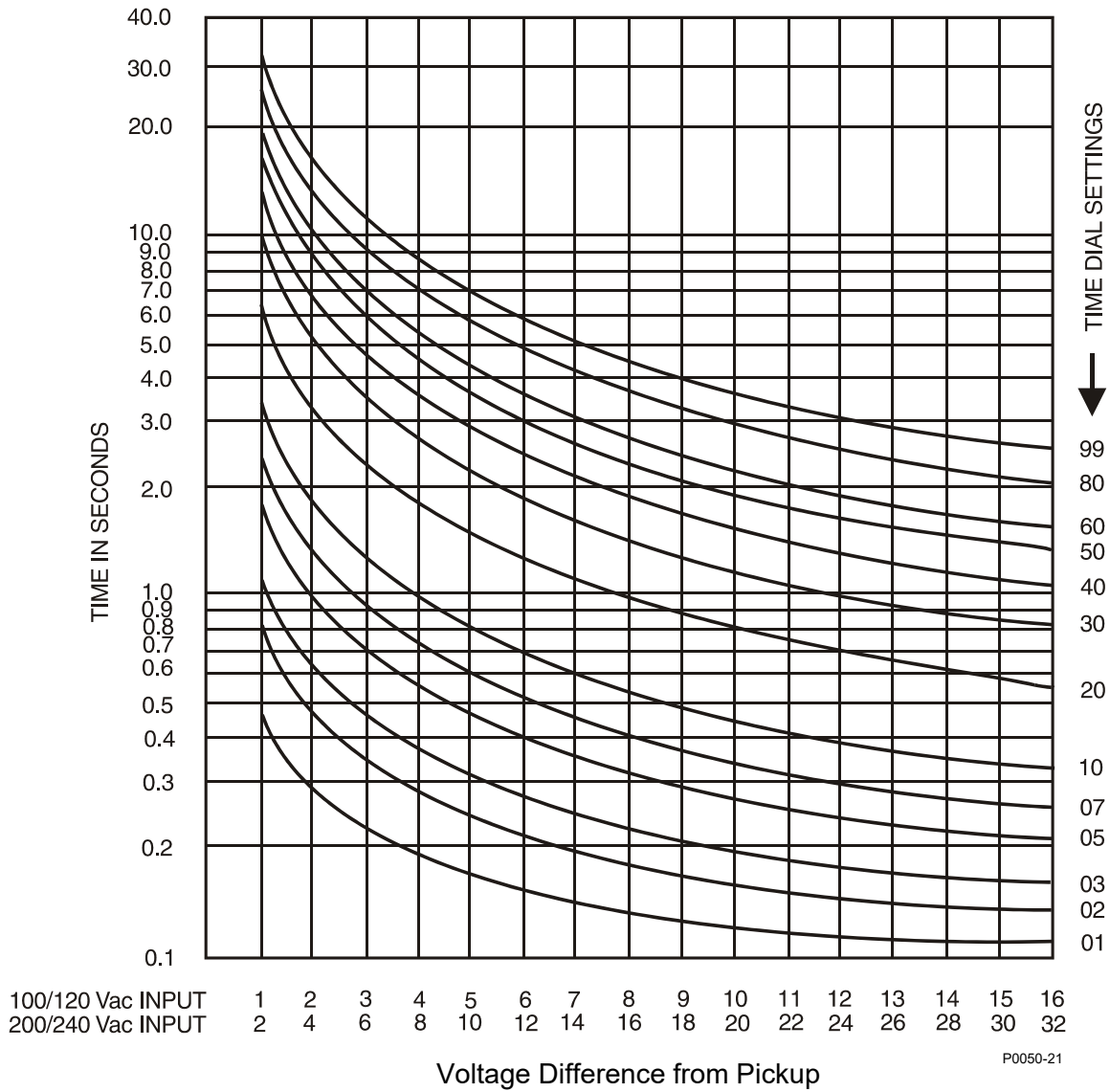
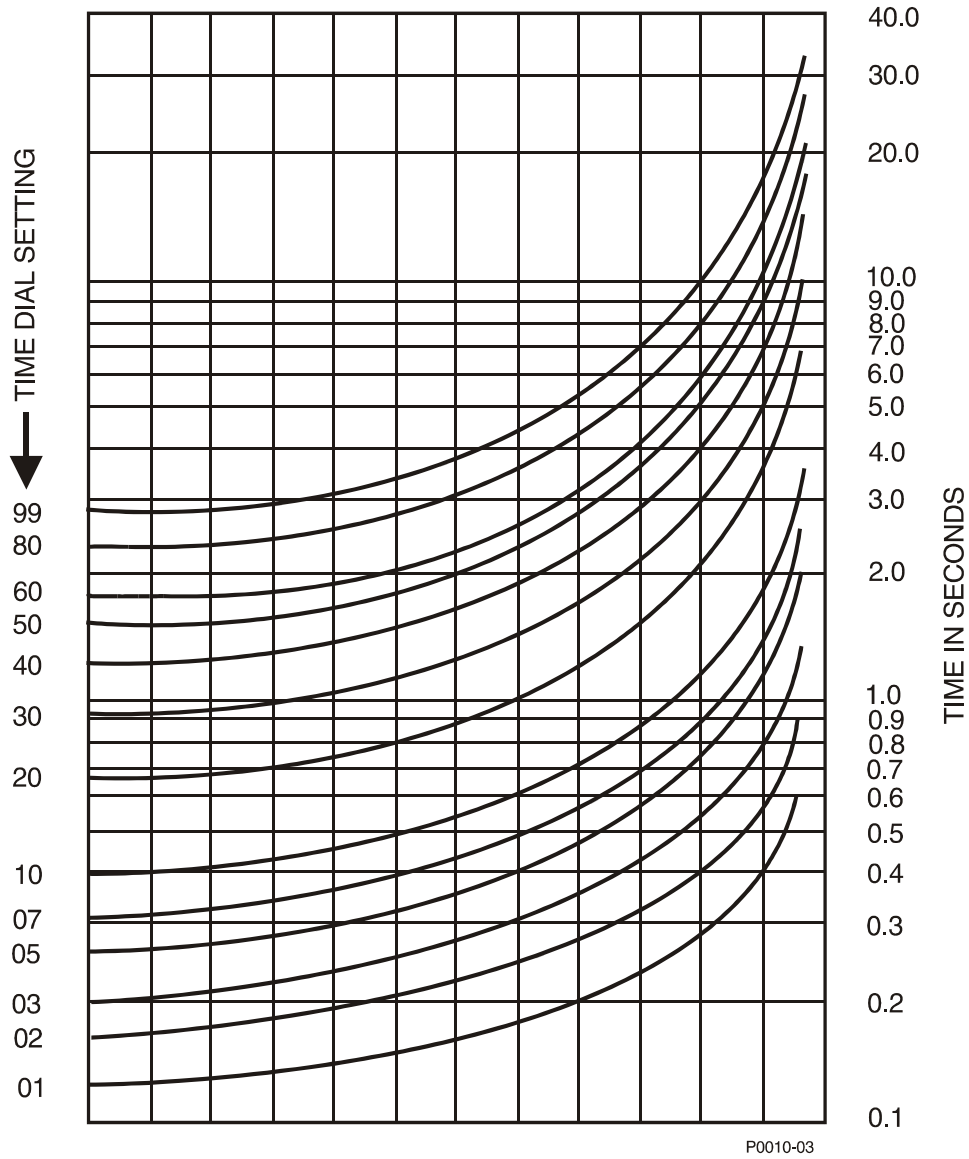

Figure 1-3. Overvoltage Inverse Time Curves



<b>SCALE A</b>	2.4	2.2	2.0	1.8	1.6	1.4	1.2	1.0	0.8	0.6	0.4	0.2
<b>SCALE B</b>	4.8	4.4	4.0	3.6	3.2	2.8	2.4	2.0	1.6	1.2	0.8	0.4
<b>SCALE C</b>	12	11	10	9	8	7	6	5	4	3	2	1
<b>SCALE D</b>	24	22	20	18	16	14	12	10	8	6	4	2

Voltage Difference from Pickup

**Figure 1-4. Undervoltage Inverse Time Curves**

**Output Contacts**

**Resistive Ratings**

- 120 Vac: Make, break, and carry 7 Aac continuously
- 250 Vdc: Make and carry 30 Adc for 0.2 s, carry 7 Adc continuously, break 0.3 Adc
- 500 Vdc: Make and carry 15 Adc for 0.2 s, carry 7 Adc continuously, break 0.3 Adc

**Inductive Ratings**

120 Vac, 125 Vdc, 250 Vdc: Break 0.3 A (L/R = 0.04)

**Power Supply**

Power supply types and specifications are listed in Table 1-1.

**Table 1-1. Power Supply Ratings**

Type	Nominal Input Voltage	Input Voltage Range	Burden at Nominal
K (midrange)	48 Vdc	24 to 150 Vdc	3.4 W
J (midrange)	125 Vdc	24 to 150 Vdc	3.6 W
	120 Vac	90 to 132 Vac	22.1 VA
L (low range)	24 Vdc	12 to 32 Vdc *	3.5 W
Y (midrange)	48 Vdc	24 to 150 Vdc	3.4 W
	125 Vdc	24 to 150 Vdc	3.6 W
Z (high range)	250 Vdc	68 to 280 Vdc	3.7 W
	240 Vac	90 to 270 Vac	37.6 VA

\* Type L power supply initially requires 14 Vdc to begin operating. Once operating, the input voltage may be reduced to 12 Vdc and operation will continue.

**Target Indicators**

Electronically latched, manually reset target indicators are optionally available to indicate closure of the trip output contacts. Either internally operated or current operated targets may be specified. Internally operated targets should be selected when normally closed (NC) output contacts are specified.

**Current Operated Targets**

Minimum Rating:	200 mA flowing through the trip circuit
Continuous Rating:	3 A
1 Second Rating:	30 A
2 Minute Rating:	7 A

**Type Tests**

Shock:	Withstands 15 G in each of three mutually perpendicular planes without structural damage or performance degradation.
Vibration:	Withstands 2 G in each of three mutually perpendicular planes, swept over the range of 10 to 500 Hz for a total of six sweeps, 15 minutes each sweep, without structural damage or degradation of performance.
Dielectric Strength:	Tested in accordance with IEC 255-5 and IEEE C37.90: 2,000 Vac applied for 1 min
Radio Frequency Interference:	Field tested using a five watt, hand-held transceiver operating at random frequencies centered around 144 MHz and 440 MHz, with the antenna located six inches from the relay in both horizontal and vertical planes.
Surge Withstand Capability:	Qualified to IEEE C37.90.1-1989, <i>Standard Surge Withstand Capability (SWC) Tests for Protective Relays and Relay Systems</i> .

**Physical**

## Temperature

Operating Range: -40 to 70°C (-40 to 158°F)

Storage Range: -65 to 100°C (-85 to 212°F)

Weight: 13.6 lb (6.17 kg)

Case Size: S1 (See Section 4 for panel cutting/drilling dimensions.)

**Agency Recognition/Certification**

## UL Recognition:

UL recognized per Standard 508, File E97033

NOTE: Output contacts are not UL recognized for voltages greater than 250 volts.

## 2 • Controls and Indicators

All BE1-59N controls and indicators are located on the front panel. The controls and indicators are shown in Figure 2-1 and described in Table 2-1. Figure 2-1 illustrates a relay with the maximum number of controls and indicators. Your relay may not have all of the controls and indicators shown and described here.

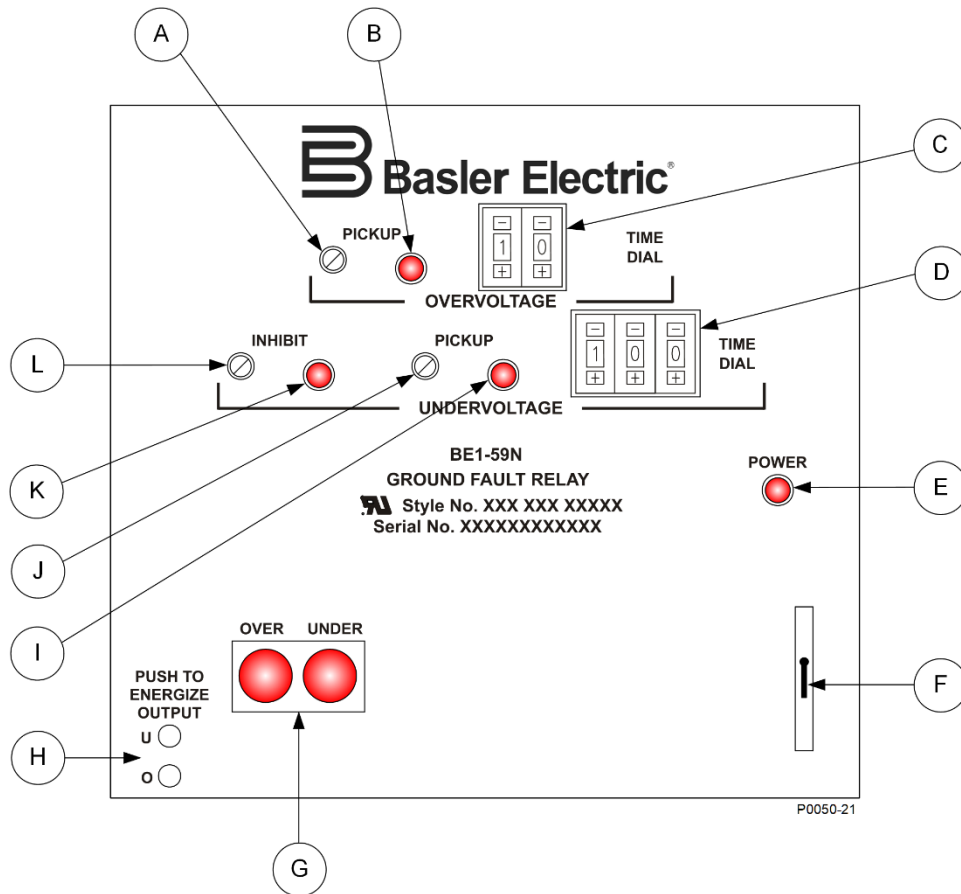

Figure 2-1. BE1-59N Controls and Indicators

Table 2-1. Control and Indicator Descriptions

Locator	Description
A	<i>Overvoltage Pickup Adjustment.</i> A multiturn potentiometer that sets the overvoltage comparator threshold voltage. Continuously adjustable over the range indicated by the style chart.
B	<i>Overvoltage Pickup LED.</i> A red LED that illuminates when overvoltage exceeds the pickup setting.
C	<i>Overvoltage Time Dial.</i> Pushbutton switch that selects the desired overvoltage output delay, either definite time (from 00.1 to 99.9 seconds) or, inverse time (characteristic curves 01 through 99). A setting of 00 is instantaneous in either case.

Locator	Description
D	<i>Undervoltage Time Dial.</i> Pushbutton switch that selects the desired undervoltage output delay, either definite time (from 00.1 to 99.9 seconds) or, inverse time (characteristic curves 01 through 99). A setting of 00 is instantaneous in either case.
E	<i>Power Indicator.</i> This red LED lights when operating power is applied to the relay.
F	<i>Target Reset Switch.</i> This switch is operated to reset the target indicators.
G	<i>Target Indicators.</i> The electronically latched red target indicators illuminate when the corresponding output relay energizes. To ensure proper operation of current-operated targets, the current flowing through the trip circuit must be 200 mA or higher. Target indicators are reset by operating the target reset switch (locator F).
H	<i>Output Test Pushbuttons.</i> These pushbuttons allow manual actuation of the output relays. Output relay actuation is achieved by inserting a nonconductive rod through the front panel access holes.
I	<i>Undervoltage Pickup LED.</i> A red LED that illuminates when undervoltage exceeds the pickup setting.
J	<i>Undervoltage Pickup Adjustment.</i> A multiturn potentiometer that sets the undervoltage comparator threshold voltage. Continuously adjustable over the range indicated by the style chart.
K	<i>Inhibit LED.</i> A red LED that illuminates when the monitored generator voltage is under the inhibit set point.
L	<i>Inhibit Pickup Adjustment.</i> Multiturn potentiometer that sets the inhibit comparator threshold so that whenever generator voltage falls below the set point, the (optional) undervoltage measuring circuitry is inhibited from operation.

## 3 • Functional Description

BE1-59N relay functions are illustrated in Figure 3-1 and described in the following paragraphs.

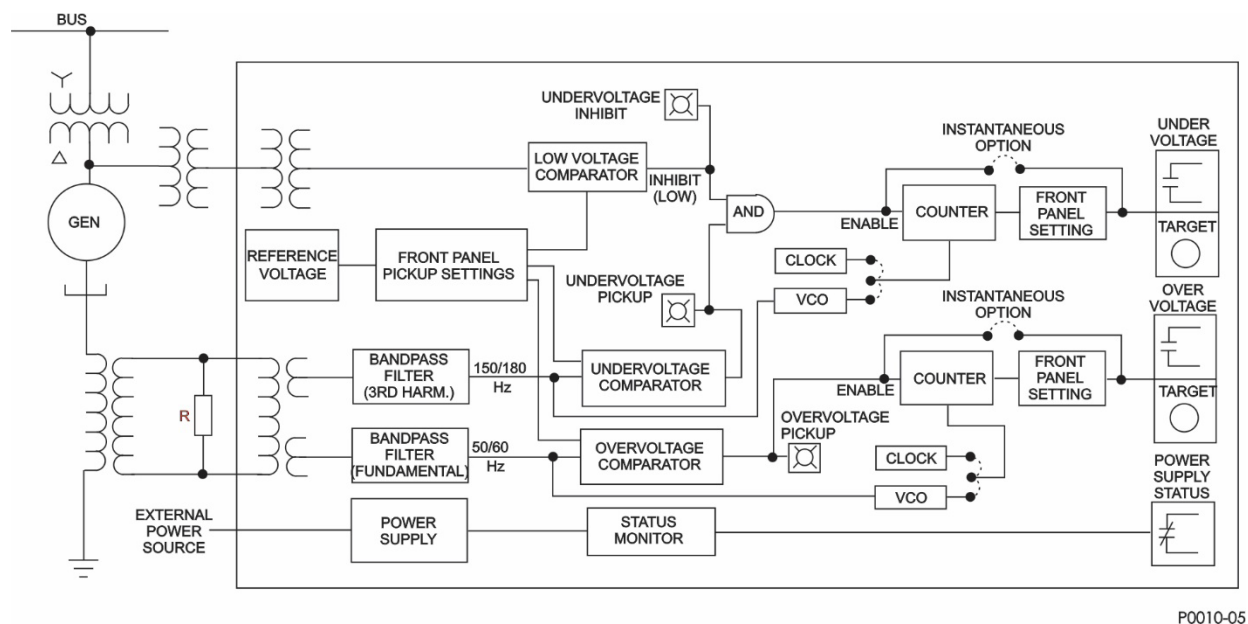

Figure 3-1. Function Block Diagram

### Inputs

The relay senses the level of voltage developed across a resistor connected in the neutral-grounding transformer secondary. The relay may also be used with ungrounded systems with voltage transformers connected in a wye/broken delta configuration. These connections are shown in Section 4.

Internal transformers provide further isolation and step down for the relay logic circuits.

### Filters

A band-pass filter provides peak sensitivity at 50 or 60 Hz for the overvoltage input, with third harmonic rejection of 40 dB minimum. If an undervoltage element is specified, an additional filter with peak sensitivity at the third harmonic is included. The filter provides 40 dB rejection of the fundamental.

### Overvoltage Comparator

The overvoltage comparator circuit receives a sensing voltage from the band-pass filter and a reference voltage from the front panel setting. The comparator determines within five cycles if the fundamental frequency (50 or 60 hertz) is less than or greater than the reference setting. When the input exceeds the setting, the resulting comparator output enables the timing circuit if definite or inverse time delay is specified, and the OVERVOLTAGE PICKUP LED illuminates. If instantaneous timing is used, the comparator output immediately energizes the overvoltage relay and, if present, the overvoltage auxiliary relay.

### Definite Time Delay (Optional)

An output signal from the comparator circuit enables a counting circuit to be incremented by an internal clock. When the counting circuit reaches a count, which matches the number entered on the TIME DIAL,

the output relay and auxiliary relay, if present, are energized. However, if the sensed input voltage falls below the pickup setting before the timer completes its cycle, the timer resets within 2.0 cycles.

The definite time delay is adjustable from 00.1 to 99.9 seconds in 0.1-second increments. Front panel mounted switches determine the delay. Position 00.0 is instantaneous.

### ***Inverse Time Delay (Optional)***

---

The inverse time delay circuit is identical to the definite time delay circuit except that a voltage-controlled oscillator (VCO) is substituted for the clock signal. The VCO, in turn, is controlled by a voltage derived from the sensed input. Because the frequency of the oscillator is kept proportional to the sensed input voltage, the desired inverse time delay is produced.

The inverse time characteristic curve switch is adjustable from 01 to 99 in 01 increments. Each position corresponds to a specific curve setting except 00, which is instantaneous. Refer to Figure 1-3 to see the inverse time characteristic curve.

### ***Reference Voltage Circuit***

---

A constant voltage source provides a reference voltage to the potentiometers on the front panel. The potentiometers, in turn, provide reference voltages to all the comparator circuits and establish the threshold for each circuit.

### ***Undervoltage Element (Optional)***

---

#### **Undervoltage Operation**

The undervoltage option is sensitive to the third harmonic voltage (150 Hz or 180 hertz) at generator neutral, and provides 40 dB rejection of the fundamental frequency (50 or 60 hertz). The undervoltage measuring element determines within five cycles if the third harmonic voltage is less than or greater than the reference setting. If the measured third harmonic voltage is less than the reference setting, the undervoltage pickup LED will illuminate, and the delay timer is triggered. When the timer completes its cycle, a signal is generated to energize the undervoltage output relay and, if selected, the undervoltage auxiliary relay. However, if the voltage level swings above the reference setting before the delay timer has cycled, the output contacts reset within 7.0 cycles.

In the event that both trip conditions (undervoltage and overvoltage) are present, the undervoltage response is inhibited.

The third harmonic pickup setting (i.e., UNDERVOLTAGE PICKUP) is a front panel mounted potentiometer, continuously adjustable on the high range from 0.5 to 12 Vac (sensing input range 1, 2, 5, or 6) or 1.0 to 24 Vac (Sensing input range 3, 4, 7, or 8). On the low range, it is adjustable from 0.1 to 2.5 Vac (sensing input range 1, 2, 5, or 6) or 0.2 to 5.0 Vac (Sensing input range 3, 4, 7, or 8). The time delays available are instantaneous, definite, or inverse time. (Instantaneous is defined as no intentional time delay. The timing circuits are analogous to those previously described.)

#### **Undervoltage Inhibit**

When the undervoltage measuring element is selected, an undervoltage inhibit circuit is included to monitor the generator terminal voltage. This circuit inhibits operation of the 150/180 hertz measuring element if the generator terminal voltage is less than the undervoltage inhibit setting. The panel mounted undervoltage inhibit potentiometer is continuously adjustable from 40 to 120 Vac for 100/120 Vac sensing input, and 80 to 240 Vac for the 200/240 Vac input.

### ***Outputs***

---

Defined by the style number, the output relays may have either a normally open (NO) or normally closed (NC) configuration. The normally open output contacts option is required when current operated targets are desired.

In addition, auxiliary output contacts (1 for Over, 1 for Under) may be provided which are specified by style number as NO or NC.

### ***Push-To-Energize Output Pushbuttons***

---

Small pushbutton switches may be provided as an option to allow testing the primary output contacts and (if present) the auxiliary output contact. To prevent accidental operation, the pushbuttons are recessed behind the front panel and are depressed by inserting a thin, non-conducting rod through an access hole in the front panel.

### ***Power Supply Status Output***

---

The power supply status relay has a set of normally closed contacts and energizes when operating power is applied to the BE1-59N. If relay operating power is lost or either side of the power supply output (+12 Vdc or -12 Vdc) fails, the power supply status relay de-energizes and closes the power supply status output contacts.

### ***Power Supply***

---

Operating power for the relay circuitry is supplied by a wide range, electrically isolated, low-burden power supply. Power supply operating power is not polarity sensitive. The front panel power LED and power supply status output indicate when the power supply is operating. Power supply specifications are listed in Table 1-1.

### ***Target Indicators***

---

Target indicators are optional components selected when a relay is ordered. The electronically latched and reset targets consist of red LED indicators located on the relay front panel. A latched target is reset by operating the target reset switch on the front panel. If relay operating power is lost, any illuminated (latched) targets are extinguished. When relay operating power is restored, the previously latched targets are restored to their latched state.

A relay can be equipped with either internally operated targets or current operated targets.

#### **Internally Operated Targets**

The relay trip outputs are directly applied to drive the appropriate target indicator. Each indicator is illuminated regardless of the current level in the trip circuit.

#### **Current Operated Targets**

A current operated target is triggered by closure of the corresponding output contact and the presence of at least 200 milliamperes of current flowing in the trip circuit.

<b>Note</b>
Prior to September 2007, BE1-59N target indicators consisted of magnetically latched, disc indicators. These mechanically latched target indicators have been replaced by the electronically latched LED targets in use today.



## 4 • Installation

BE1-59N relays are shipped in sturdy cartons to prevent damage during transit. Upon receipt of a relay, check the model and style number against the requisition and packing list to see that they agree. Inspect the relay for shipping damage. If there is evidence of damage, file a claim with the carrier, and notify your sales representative or Basler Electric.

If the relay will not be installed immediately, store it in its original shipping carton in a moisture- and dust-free environment. Before placing the relay in service, it is recommended that the test procedures of Section 5, *Testing* be performed.

### ***Relay Operating Guidelines and Precautions***

---

Before installing or operating the relay, note the following guidelines and precautions.

- For proper current operated target operation, a minimum current of 200 milliamperes must flow through the output trip circuit.
- If a wiring insulation test is required, remove the connection plugs and withdraw the relay from its case.

#### **Caution**

When the connection plugs are removed, the relay is disconnected from the operating circuit and will not provide system protection. Always be sure that external operating (monitored) conditions are stable before removing a relay for inspection, test, or service.

#### **Note**

Be sure that the relay is hard-wired to earth ground with no smaller than 12 AWG copper wire attached to the ground terminal on the rear of the case. When the relay is configured in a system with other devices, it is recommended to use a separate lead to the ground bus from each device.

It is recommended in all applications where contact outputs drive relay coils that a reverse biased diode be implemented in parallel with the relay coil for EMI suppression.

### ***MOUNTING***

---

Because the relay is of solid-state design, it does not have to be mounted vertically. Any convenient mounting angle may be chosen. Relay outline dimensions and panel drilling diagrams are illustrated in Figures 4-1 through 4-7.

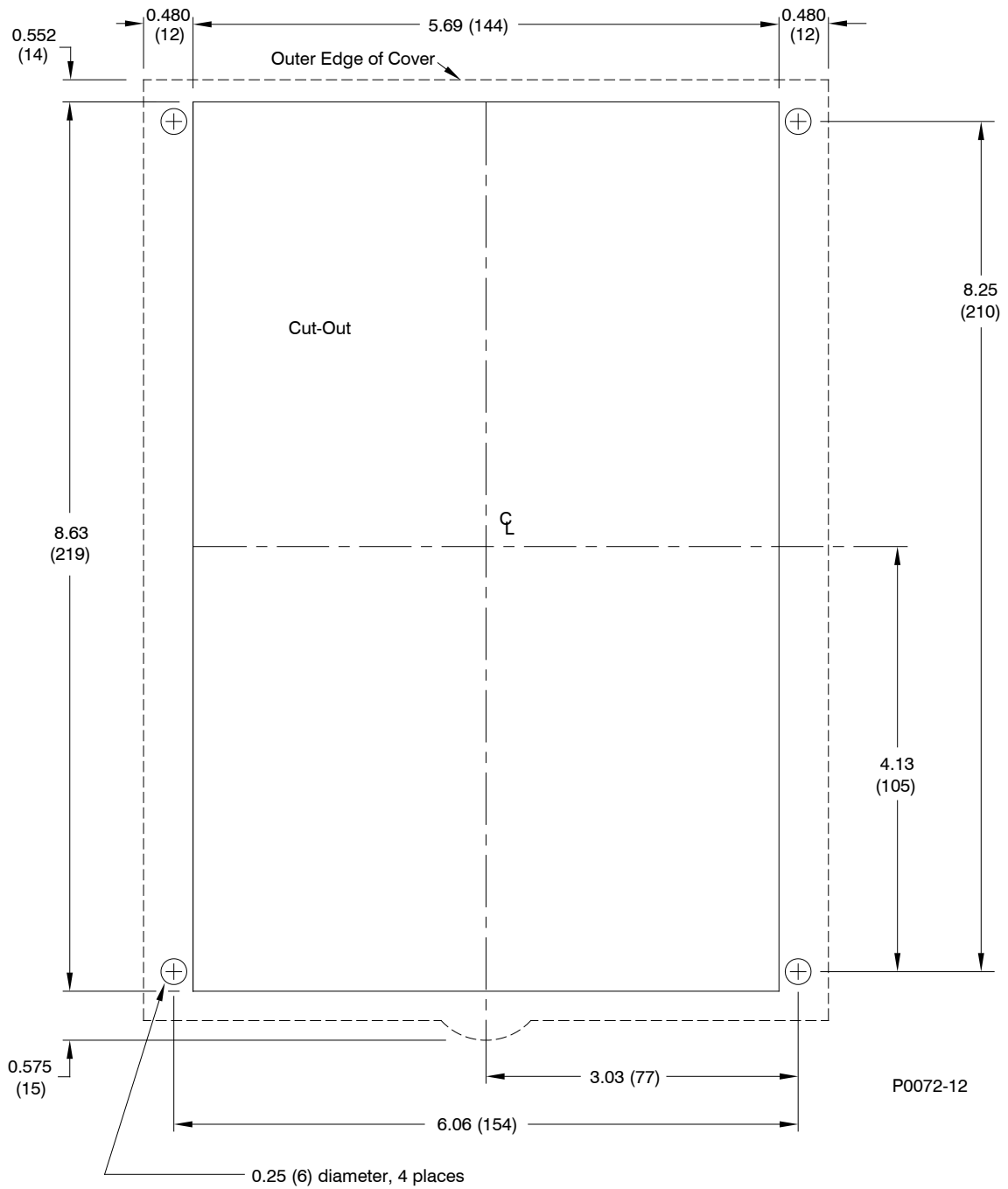

Figure 4-1. Panel Cutting/Drilling, Semi-Flush, S1 Case

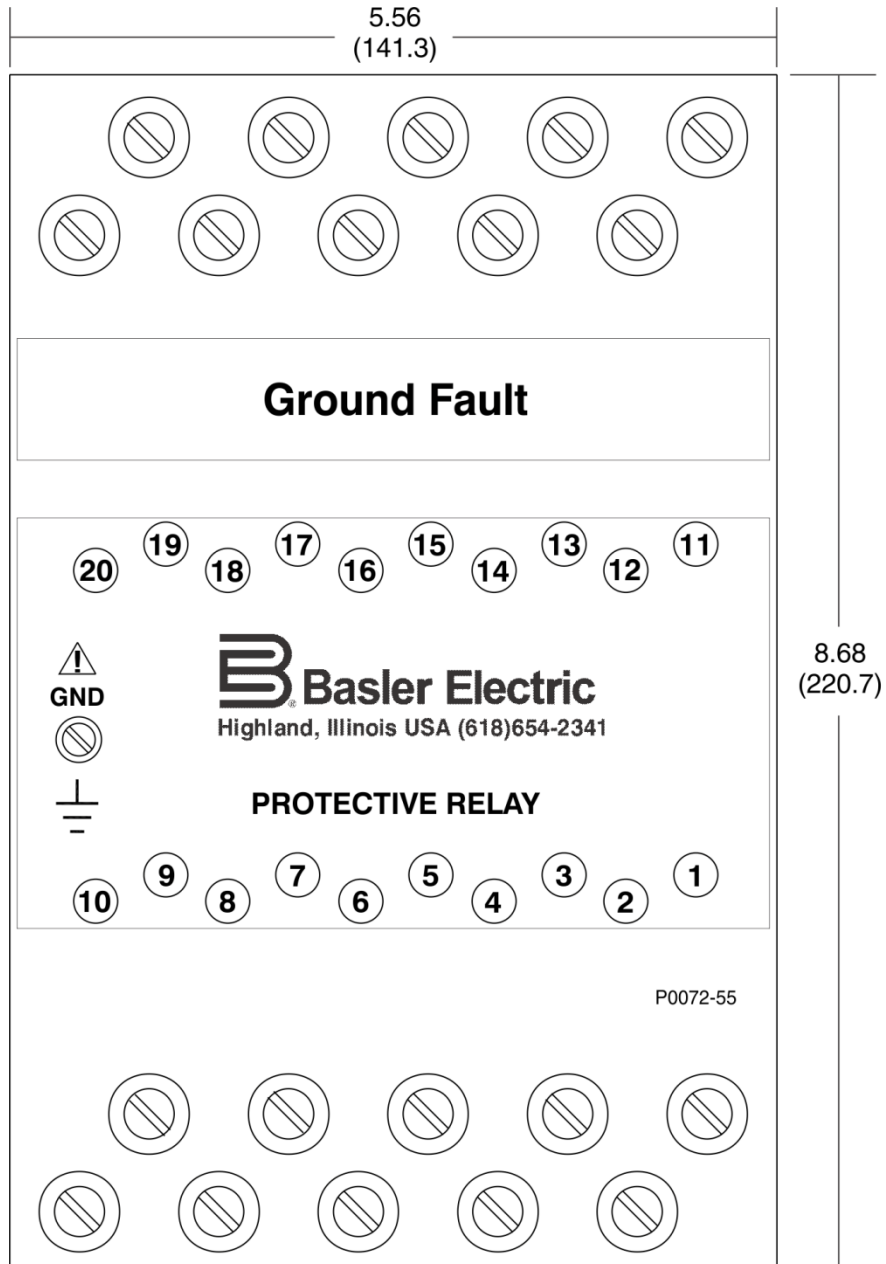

Figure 4-2. S1 Case Dimensions, Rear View, Double Ended, Semi-Flush Mount

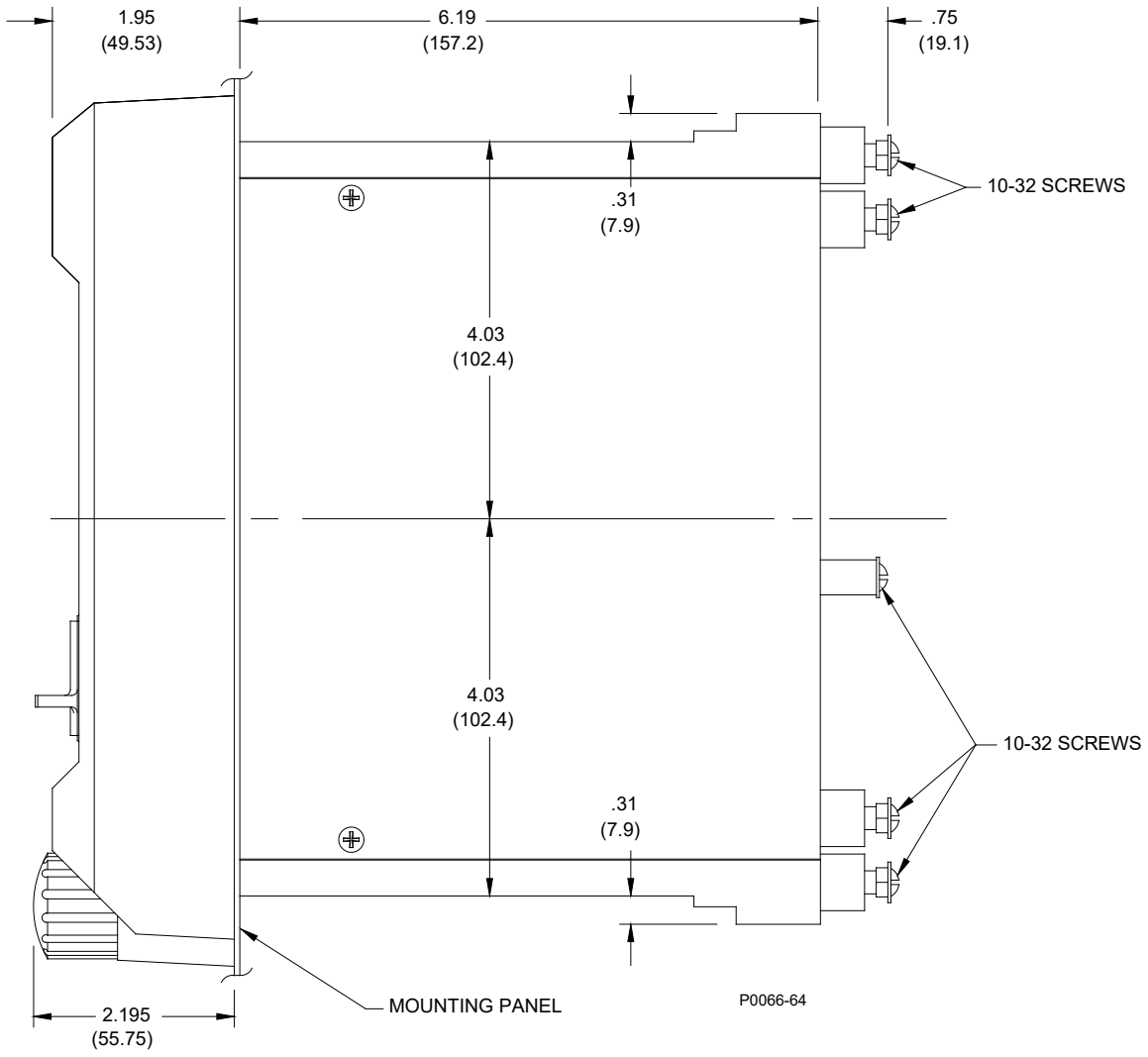

Figure 4-3. S1 Case Dimensions, Side View, Double Ended, Semi-Flush Mount

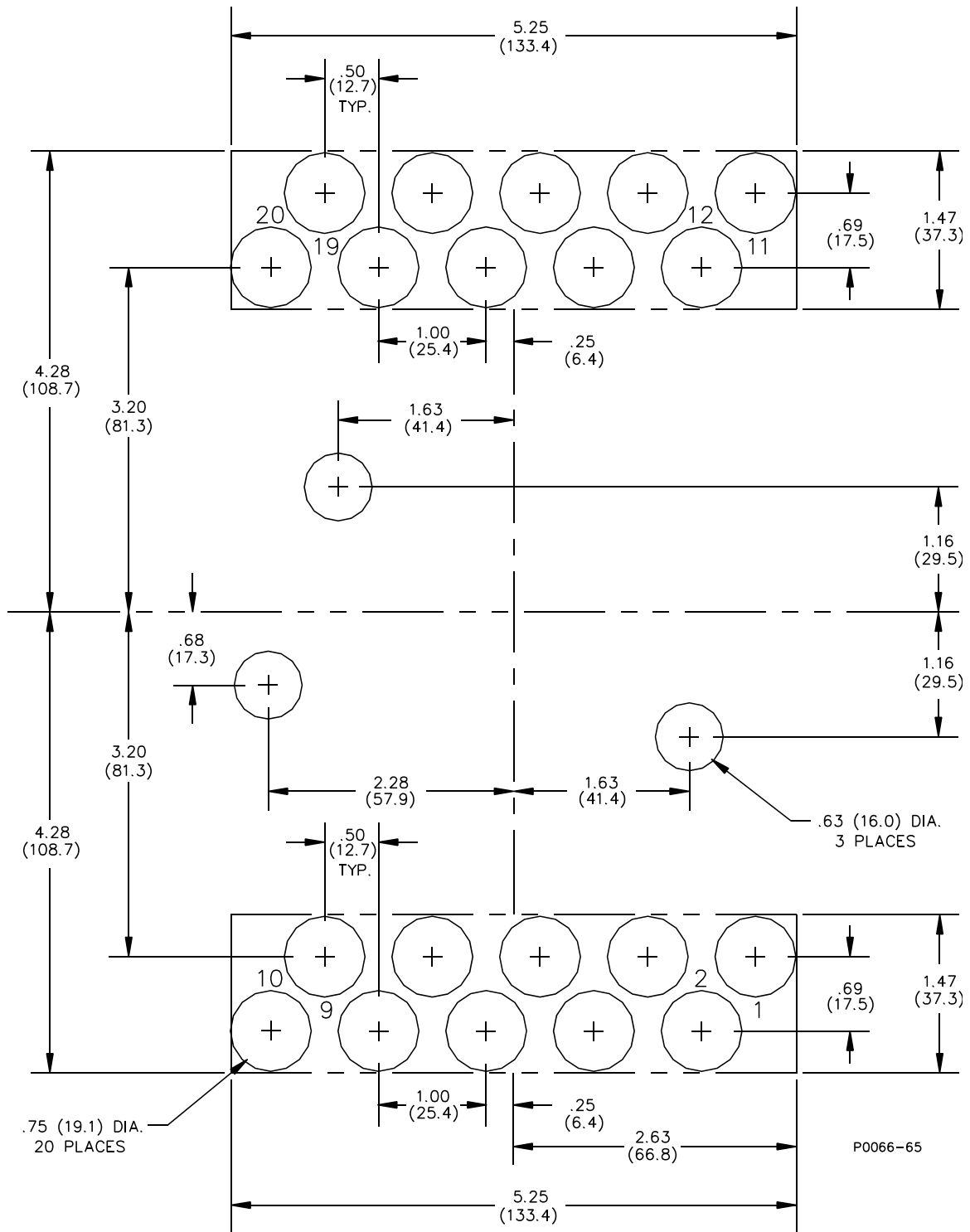

Figure 4-4. Panel Cutting/Drilling, Double Ended, Projection Mount

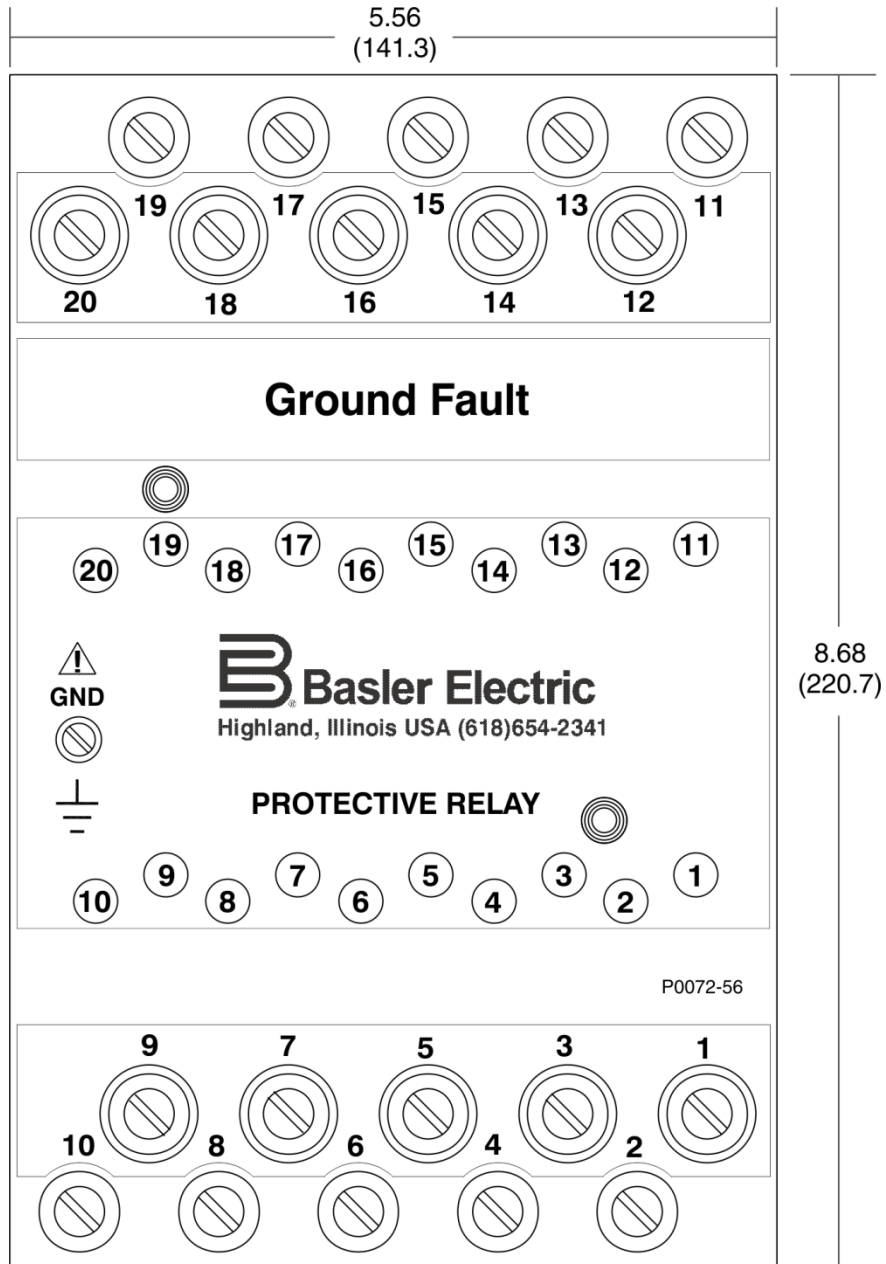
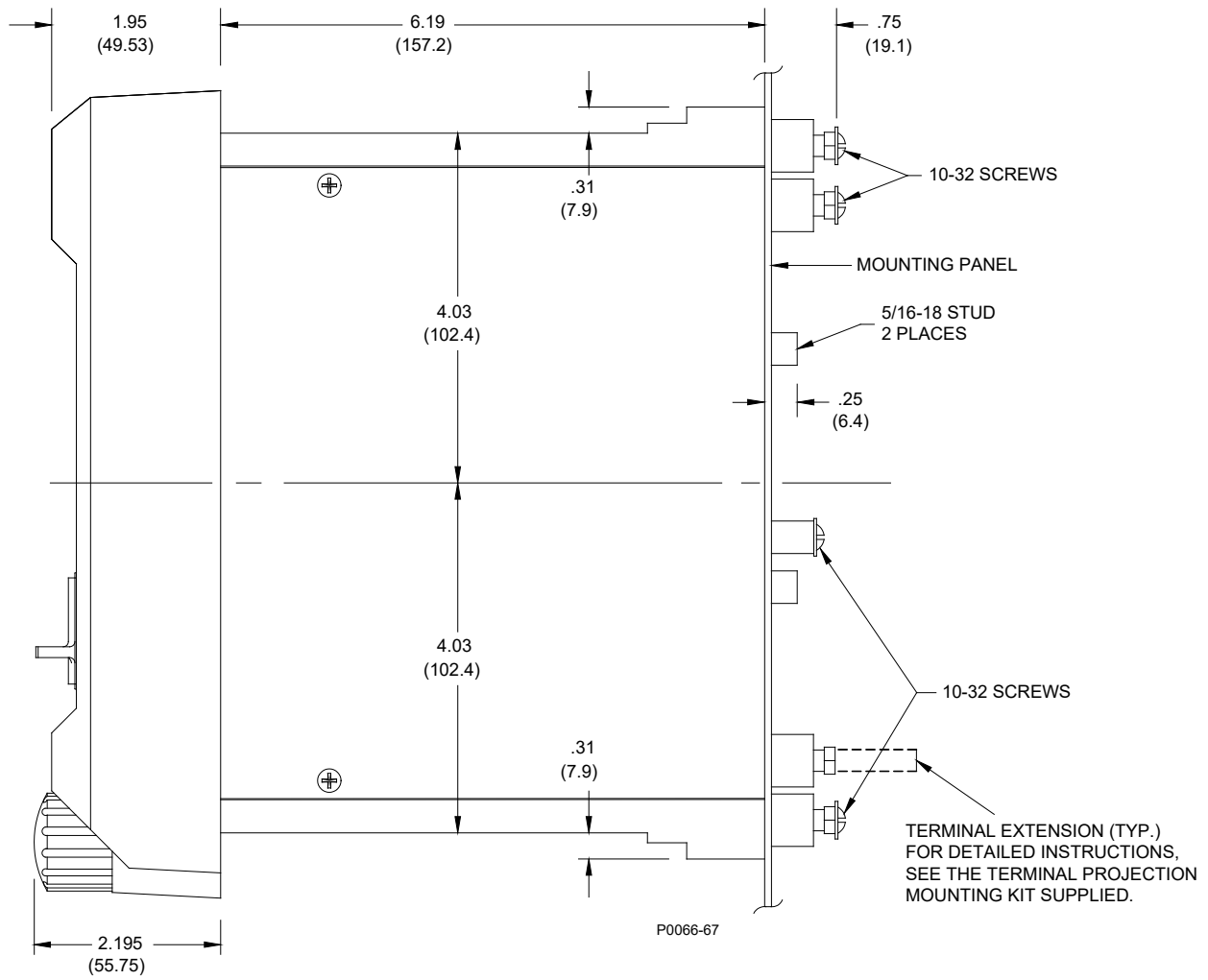
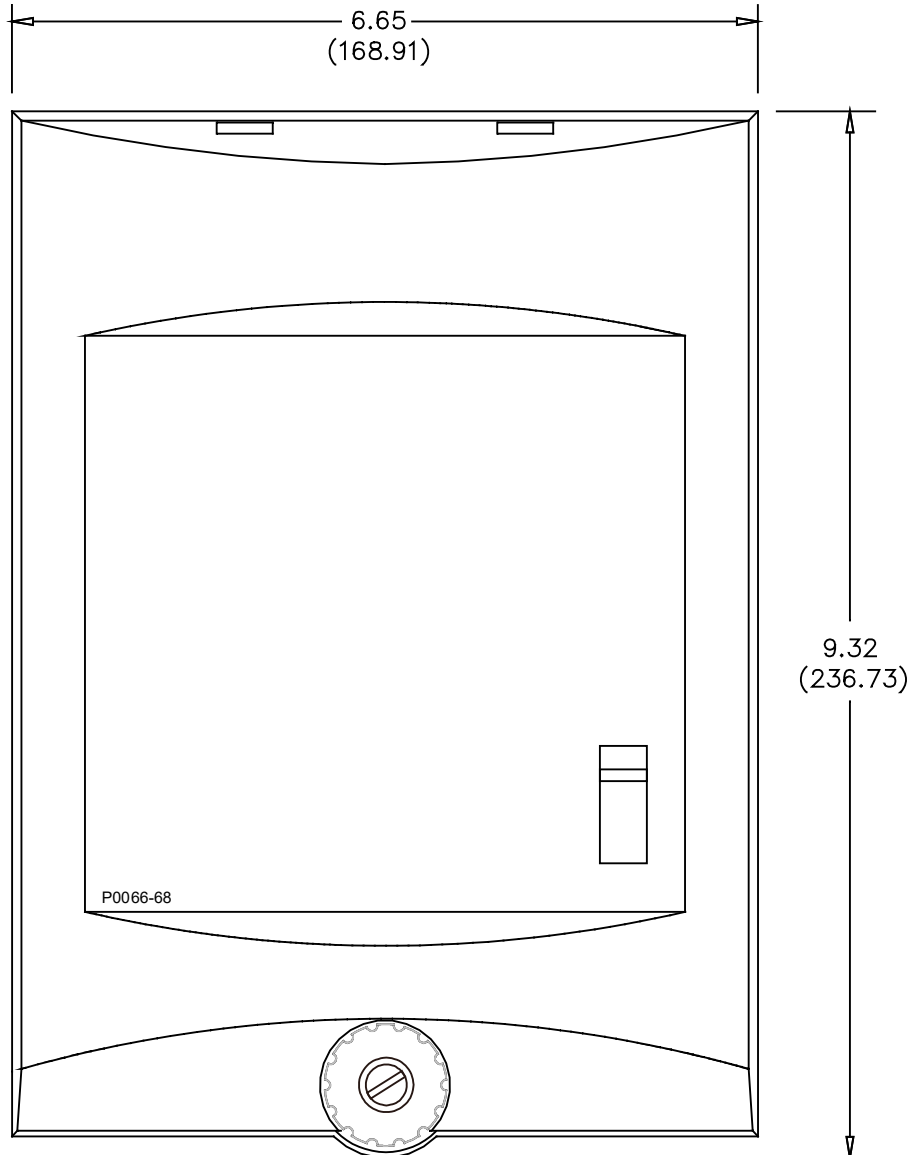

Figure 4-5. S1 Case Dimensions, Rear View, Double Ended, Projection Mount



**Figure 4-6. S1 Case Dimensions, Side View, Double Ended, Projection Mount**



**Figure 4-7. S1 Case Cover Dimensions, Front View**

## **Connections**

Be sure to check the model and style number of a relay before connecting and energizing the relay. Incorrect wiring may result in damage to the relay. Except where noted, connections should be made with wire no smaller than 14 AWG.

Typical external connections are shown in Figures 4-8 and 4-9. Typical internal connections are shown in Figure 4-10.

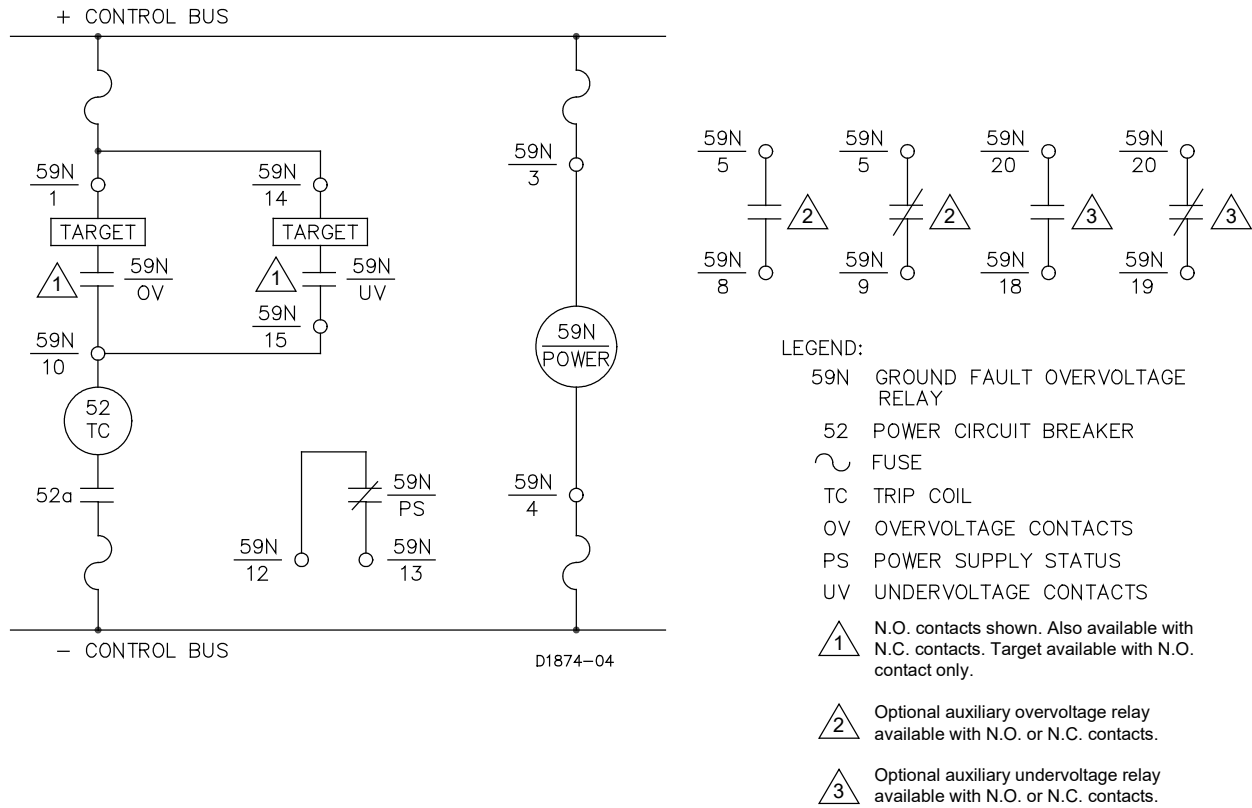
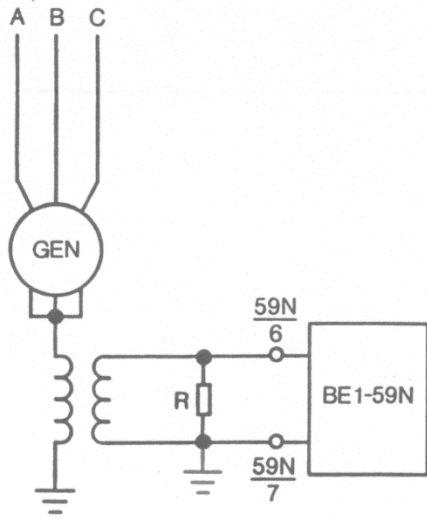
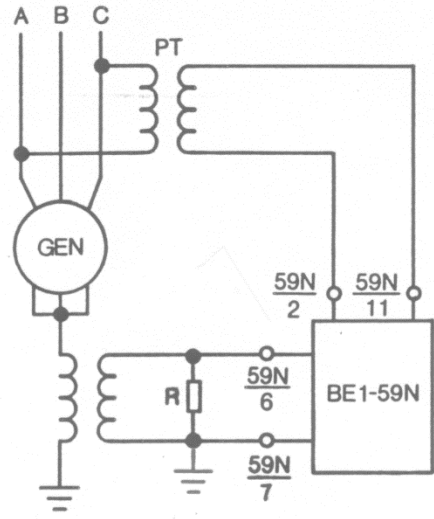

Figure 4-8. Control Circuit Diagram



GROUND FAULT OVERVOLTAGE



OVERLAPPING GROUND FAULT  
(UNDervOLTAGE AND OVERVOLTAGE)

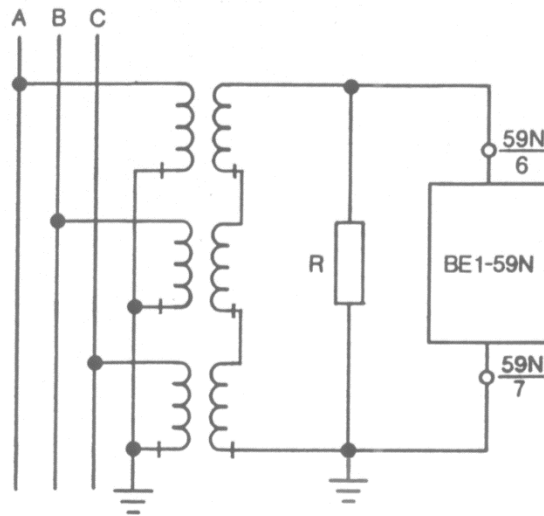

UNGROUND SYSTEM

P0087-71

Figure 4-9. Sensing Input Connections

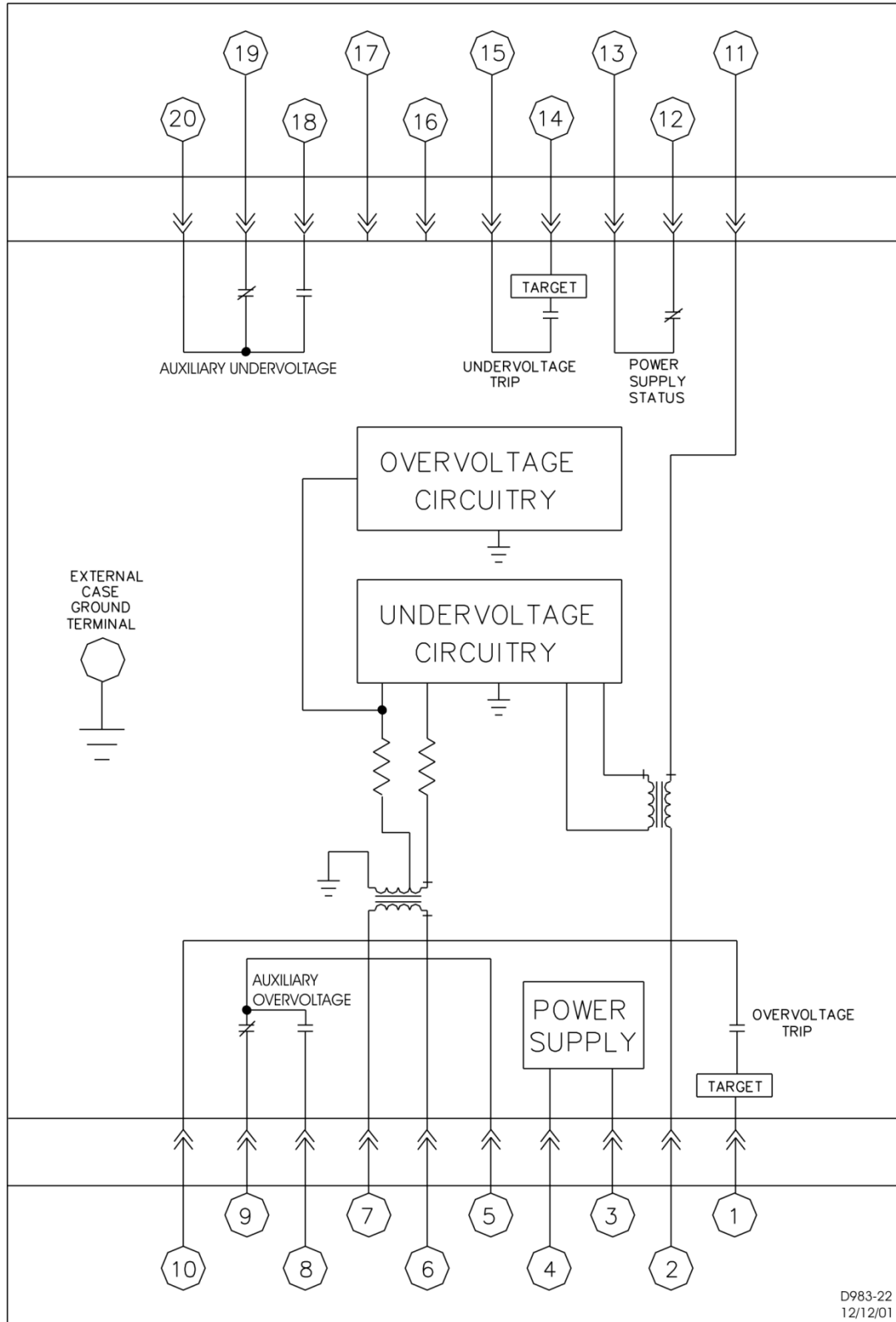

Figure 4-10. Typical Internal Connection Diagram with Optional, Normally-Open Output Contacts

---

## ***Maintenance***

---

BE1-59N relays require no preventative maintenance other than a periodic operational check. If the relay fails to function properly, contact Technical Sales Support at Basler Electric to coordinate repairs.

## ***Storage***

---

This device contains long-life aluminum electrolytic capacitors. For devices that are not in service (spares in storage), the life of these capacitors can be maximized by energizing the device for 30 minutes once per year.

## 5 • Functional Description

The following procedures verify proper relay operation and calibration.

Results obtained from these procedures may not fall within specified tolerances. When evaluating results, consider three prominent factors:

- Test equipment accuracy
- Testing method
- External test set components tolerance level

### Operational Test

Step 1. Perform test setup (Figure 5-1) and apply power to the relay. Verify that the POWER LED is ON, and that the power supply status contact is open.

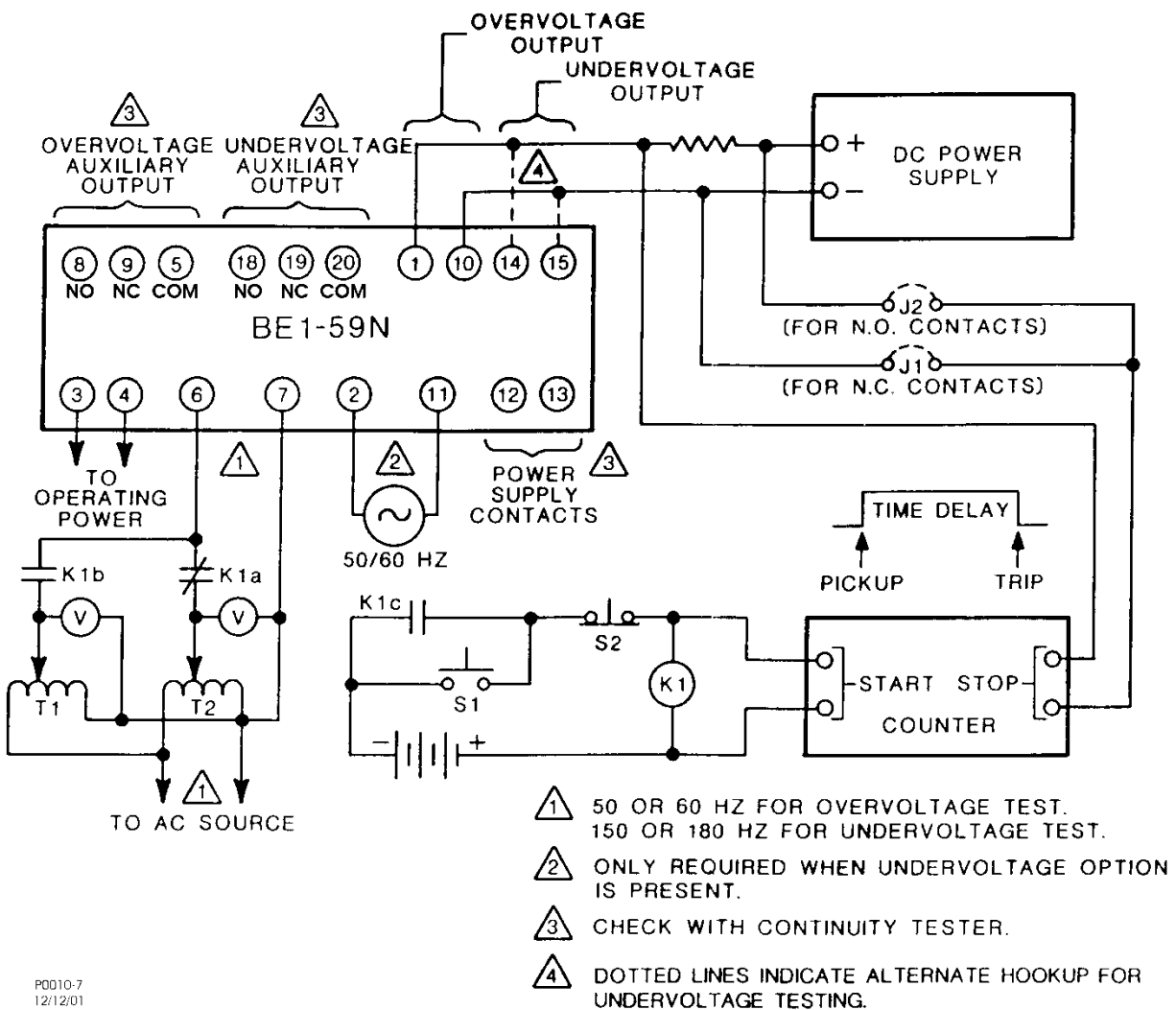

P0010-7  
12/12/01

Figure 5-1. Typical Test Setup

- Step 2. Set all TIME DIALS (if any) to the zero position.
- Step 3. Connect an ac voltage source (50 or 60 Hz, depending upon input option) to input terminals 6 and 7. Adjust this voltage to equal the desired overvoltage pickup level.
- Step 4. Rotate the front panel OVERVOLTAGE PICKUP potentiometer fully clockwise (20 turns). You may discern a light clicking sound as the potentiometer reaches its clockwise limit. Slowly turn CCW until the associated LED just illuminates. Interrupt and then reclose sensing power to terminals 6 and 7, noting the time between application of power and trip of overvoltage relay. Time must be less than 70 milliseconds (60 Hz) or 84 milliseconds (50 Hz) for a voltage level that exceeds the pickup setting by 1 volt or 5% of the setting, whichever is greater.

<b>Note</b>
Step 5 applies only to relays with overvoltage definite time delay.

- Step 5. Open the sensing input and reset the target indicator. Set the OVERVOLTAGE TIME DIAL for the desired delay. Close the sensing input and verify that the relay trips according to the setting. Accuracy is  $\pm 2\%$  or 100 ms, whichever is greater.
- Step 6. Connect a 50/60 Hz source to relay terminals 6 and 7 as shown in Figure 5-1. Note that this setup allows rapid switching from a voltage that is approximately one-half of pickup to a voltage ( $\Delta V$ ) that is higher than pickup. The switching also provides a means of precisely verifying the time between the voltage step change and the resulting output response.

<b>Note</b>
Steps 6 through 12 apply only to relays with overvoltage inverse time delay.

- Step 7. Set the OVERVOLTAGE TIME DIAL to the desired characteristic curve. (Reference Figure 1-3.)
- Step 8. Adjust T1 to the desired pickup voltage.
- Step 9. Adjust T2 to the sum of the desired pickup voltage and  $\Delta V$ .
- Step 10. Press and release S2 (of Figure 5-1) to assure that K1 is de-energized. Reset the timer. Press S1. The timer recorded by the counter should be within 5% or 25 milliseconds (whichever is greater) of the time given in Figure 1-3 for the particular  $\Delta V$  of the test.
- Step 11. By changing  $\Delta V$ , steps 9 and 10 may be repeated to verify any segment of the characteristic curve that is of interest.

<b>Note</b>
If the Undervoltage option is included, proceed with the following steps. Otherwise, the Operational Test is concluded.

- Step 12. Connect 100 Vac at 50/60 Hz to terminals 2 and 11. Set the UNDERVOLTAGE INHIBIT potentiometer to the maximum CCW position. INHIBIT LED should be OFF.
- Step 13. Connect a 150 or 180 Hz voltage source (i.e., 3 times specified frequency) to input terminals 6 and 7. Adjust this voltage to the desired undervoltage threshold level. Rotate the UNDERVOLTAGE PICKUP potentiometer fully counterclockwise (20 turns). You may discern a light clicking sound as the potentiometer reaches its counterclockwise limit. Reset targets.

- Step 14. Rotate the UNDERVOLTAGE PICKUP potentiometer slowly CW until the UNDERVOLTAGE LED just illuminates. At this time, the undervoltage relay(s) and undervoltage auxiliary relay (if so equipped) should be energized, and undervoltage target tripped.
- Step 15. Adjust the UNDERVOLTAGE INHIBIT potentiometer so that the INHIBIT LED just illuminates. At this time, the UNDERVOLTAGE LED should extinguish, and the undervoltage relay(s) should de-energize. To disable the inhibit function for the remainder of the test procedure, rotate the UNDERVOLTAGE INHIBIT potentiometer fully clockwise (20 turns). You may discern a light clicking sound as the potentiometer reaches its clockwise limit.

Note
Steps 16 through 18 apply only to relays with undervoltage definite time delay. If not so equipped, proceed to the note following step 18.

- Step 16. Adjust the 150 or 180 Hz voltage (at terminals 6 and 7) to above pickup (i.e., UNDERVOLTAGE LED OFF).
- Step 17. Set the UNDERVOLTAGE TIME DIAL for any convenient delay. Reset targets (if present).
- Step 18. Reduce the sensing input below pickup (or disconnect it) while noting the time lapse before the undervoltage relay(s) trip. Check that response time is the TIME DIAL setting  $\pm 525$  milliseconds.

Note
The remaining steps of this procedure apply only to relays with undervoltage inverse time delay. For all other relays, the operational test is concluded.

- Step 19. Connect a 150/180 Hz source to relay terminals 6 and 7 as shown in Figure 5-1. Note that this setup allows rapid switching from a voltage that is approximately twice pickup to a voltage that is  $\Delta V$  lower than pickup. The switching also provides a means of precisely verifying the time between the voltage step change and the resulting output response.
- Step 20. Set the UNDERVOLTAGE TIME DIAL to the desired characteristic curve. (Reference Figure 1-4.)
- Step 21. Adjust the voltage output of T2 to twice that of T1.
- Step 22. Decrease the voltage of T1 by an amount that represents any  $\Delta V$  of interest.
- Step 23. Press and release S2 (of Figure 5-1) to assure that K1 is de-energized. Reset the timer. Press S1. The time recorded by the counter should be within 5% or 25 milliseconds (whichever is greater) of the time given in Figure 1-4.
- Step 24. By changing  $\Delta V$ , steps 22 and 23 may be repeated to verify any segment of the characteristic curve that is of interest.





