

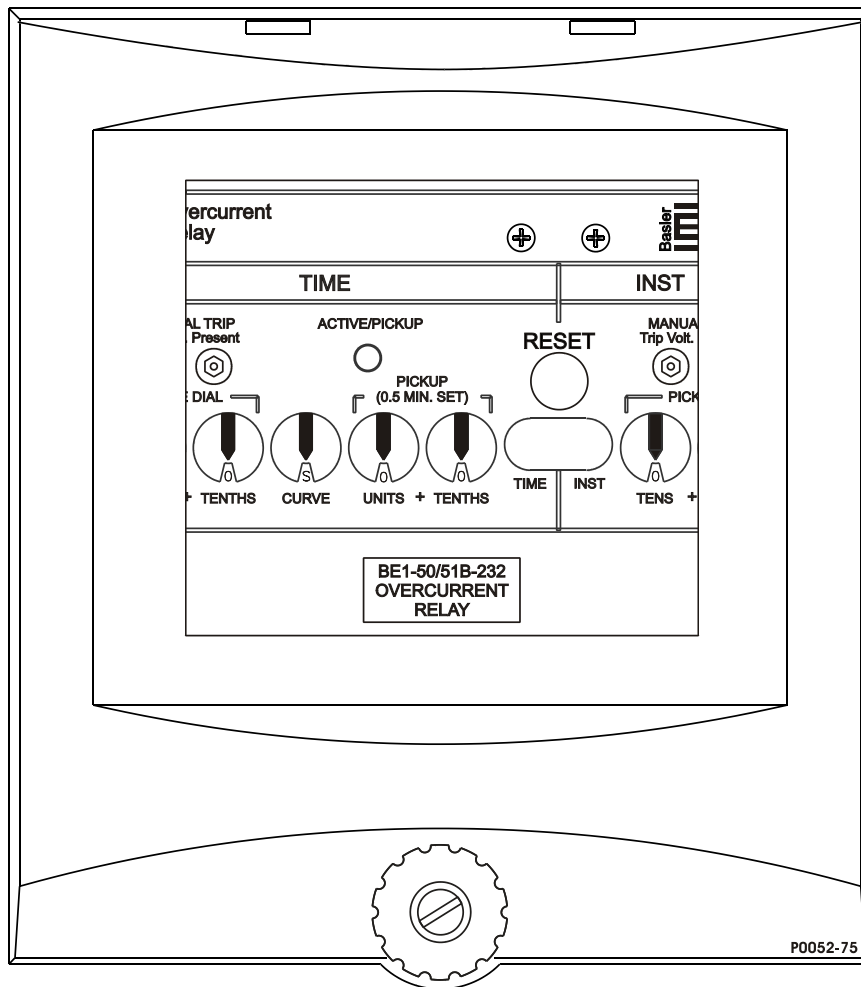



BE1-50/51B-232

Overcurrent Relay

Instruction Manual



 **WARNING:** California's Proposition 65 requires special warnings for products that may contain chemicals known to the state of California to cause cancer, birth defects or other reproductive harm. Please note that by posting this Proposition 65 warning, we are notifying you that one or more of the Proposition 65 listed chemicals may be present in products we sell to you. For more information about the specific chemicals found in this product, please visit <https://www.basler.com/Prop65>.

Preface

This instruction manual provides information about the installation and operation of the BE1-50/51B-232. To accomplish this, the following information is provided:

- General information and specifications
- Controls and indicators
- Functional description
- Installation and maintenance
- Testing

Conventions Used in this Manual

Important safety and procedural information is emphasized and presented in this manual through warning, caution, and note boxes. Each type is illustrated and defined as follows.

Warning!

Warning boxes call attention to conditions or actions that may cause personal injury or death.

Caution

Caution boxes call attention to operating conditions that may lead to equipment or property damage.

Note

Note boxes emphasize important information pertaining to installation or operation.



12570 State Route 143
Highland IL 62249-1074 USA

www.basler.com

info@basler.com

Tel: +1 618.654.2341

Fax: +1 618.654.2351

© 2025 by Basler Electric

All rights reserved

First printing: January 2007

Warning!

READ THIS MANUAL. Read this manual before installing, operating, or maintaining this equipment. Note all warnings, cautions, and notes in this manual as well as on the product. Keep this manual with the product for reference. Only qualified personnel should install, operate, or service this system. Failure to follow warning and cautionary labels may result in personal injury or property damage. Exercise caution at all times.

Basler Electric does not assume any responsibility to compliance or noncompliance with national code, local code, or any other applicable code. This manual serves as reference material that must be well understood prior to installation, operation, or maintenance.

For terms of service relating to this product and software, see the *Commercial Terms of Products and Services* document available at www.basler.com/terms.

This publication contains confidential information of Basler Electric Company, an Illinois corporation. It is loaned for confidential use, subject to return on request, and with the mutual understanding that it will not be used in any manner detrimental to the interests of Basler Electric Company and used strictly for the purpose intended.

It is not the intention of this manual to cover all details and variations in equipment, nor does this manual provide data for every possible contingency regarding installation or operation. The availability and design of all features and options are subject to modification without notice. Over time, improvements and revisions may be made to this publication. Before performing any of the following procedures, contact Basler Electric for the latest revision of this manual.

The English-language version of this manual serves as the only approved manual version.

Revision History

A historical summary of the changes made to this instruction manual is provided below. Revisions are listed in reverse chronological order.

Instruction Manual Revision History

Manual Revision and Date	Change
E, Mar 2025	<ul style="list-style-type: none"> Updated China RoHS table.
D, Nov 2024	<ul style="list-style-type: none"> Updated manual to reflect changes to main board. Target-operating current selection jumpers were added. Updated burden data.
C, Feb 2024	<ul style="list-style-type: none"> Added China RoHS compliance. Minor text edits.
B, Dec 2008	<ul style="list-style-type: none"> Updated <i>Storage</i> statement in Section 4. Modified Figure 5-2, <i>Target Operational Test Setup</i>. In Section 5, <i>Testing</i>, removed list of required tools and removed steps about disconnecting and re-connecting relay terminal wires. Modified <i>Target Test</i> so that TIME and INST targets can be verified independently from each other. Minor text edits throughout manual.
A, Mar 2008	<ul style="list-style-type: none"> Updated front panel drawings to show new target reset button.
—, Jan 2007	<ul style="list-style-type: none"> Initial release



Contents

Introduction	1-1
Controls and Indicators	2-1
Functional Description.....	3-1
Installation.....	4-1
Testing.....	5-1
Specifications.....	6-1
Time Characteristic Curves	7-1



1 • Introduction

BE1-50/51B-232 protective relays are direct replacements for General Electric IAC relays. BE1-50/51B-232 protective relays are enclosed in an S1 case. The BE1-50/51B-232 has a 5-ampere current sensing input. Compatible IAC model numbers are listed in Table 1-1.

Table 1-1. GE IAC Relays Suitable for Direct Replacement

IAC Model Number	Curve Type
12IAC51A***A	Inverse
12IAC51B***A	Inverse with Instantaneous
12IAC53A***A	Very Inverse
12IAC53B***A	Very Inverse with Instantaneous
12IAC55A***A	Short Time
12IAC55B***A	Short Time with Instantaneous
12IAC66A***A	Long Time
12IAC66B***A	Long Time with Instantaneous
12IAC77A***A	Extremely Inverse
12IAC77B***A	Extremely Inverse with Instantaneous

* Any digit covering all pickup ranges except 50-Hz models.

Basler Electric BE1-50/51B-232 protective relays are self-powered, microprocessor-based, non-directional phase or ground relays that monitor the magnitude of a single-phase ac current to provide accurate instantaneous and time overcurrent protection for 60-Hz power systems. Each model covers 15 popular time characteristics, a wide range of pickup settings, and field selectable instantaneous or integrating reset.

Features

A wide range of pickup settings and front panel selectable time characteristics permit applications involving coordination with fuses, reclosers, cold load pickup, motor starting, and fixed time requirements. Also, an integrating reset function is available to simulate the disk reset of electromechanical relays.

BE1-50/51B-232 overcurrent relays have the following standard features.

- Independent time and instantaneous elements
- A secure method to manually trip the breaker at the relay front panel
- Direct reading front panel controls
- Minimum pickup setting for safety during installation
- Time characteristics extend to a pickup multiple of 40
- Rugged draw-out construction with steel case
- Gravity-latching targets retain indication without power
- Built-in accuracy eliminates internal adjustments
- Minimum transient overreach
- Field-selectable characteristic curve selection similar to either GE-IAC- or ABB-type curves
- Field-selectable instantaneous or integrating reset
- Field-selectable 0.0, 0.1, 0.2, or 0.3 second fixed instantaneous delay

Internal switches provide for selecting instantaneous element delays of 0.0, 0.1, 0.2, or 0.3 second, characteristic curve group selection for either GE-IAC- or ABB-type curves, and instantaneous or integrating reset characteristics. Switch location and description is provided in Section 2.

Advantages

BE1-50/51B-232 overcurrent relays have many advantages over other overcurrent relays. The primary advantages are:

- Time characteristics are defined by equations and graphs
- Field-selectable time characteristics
- Very low burden extends the linear range of the CTs
- Self-powered from the sensed current
- Continuous automatic calibration

BE1-50/51B-232 overcurrent relays may be tested without removing the relay from the case. Shorting contacts are provided for all current inputs when the connection plugs or relay chassis is removed from the relay case.

2 • Controls and Indicators

Figure 2-1 illustrates the front panel controls and indicators of the BE1-50/51B-232. Figure 2-2 illustrates the location of switch SW3, J1, and J2. Both illustrations have lettered call-outs that correspond to the control and indicator descriptions provided in Table 2-1.

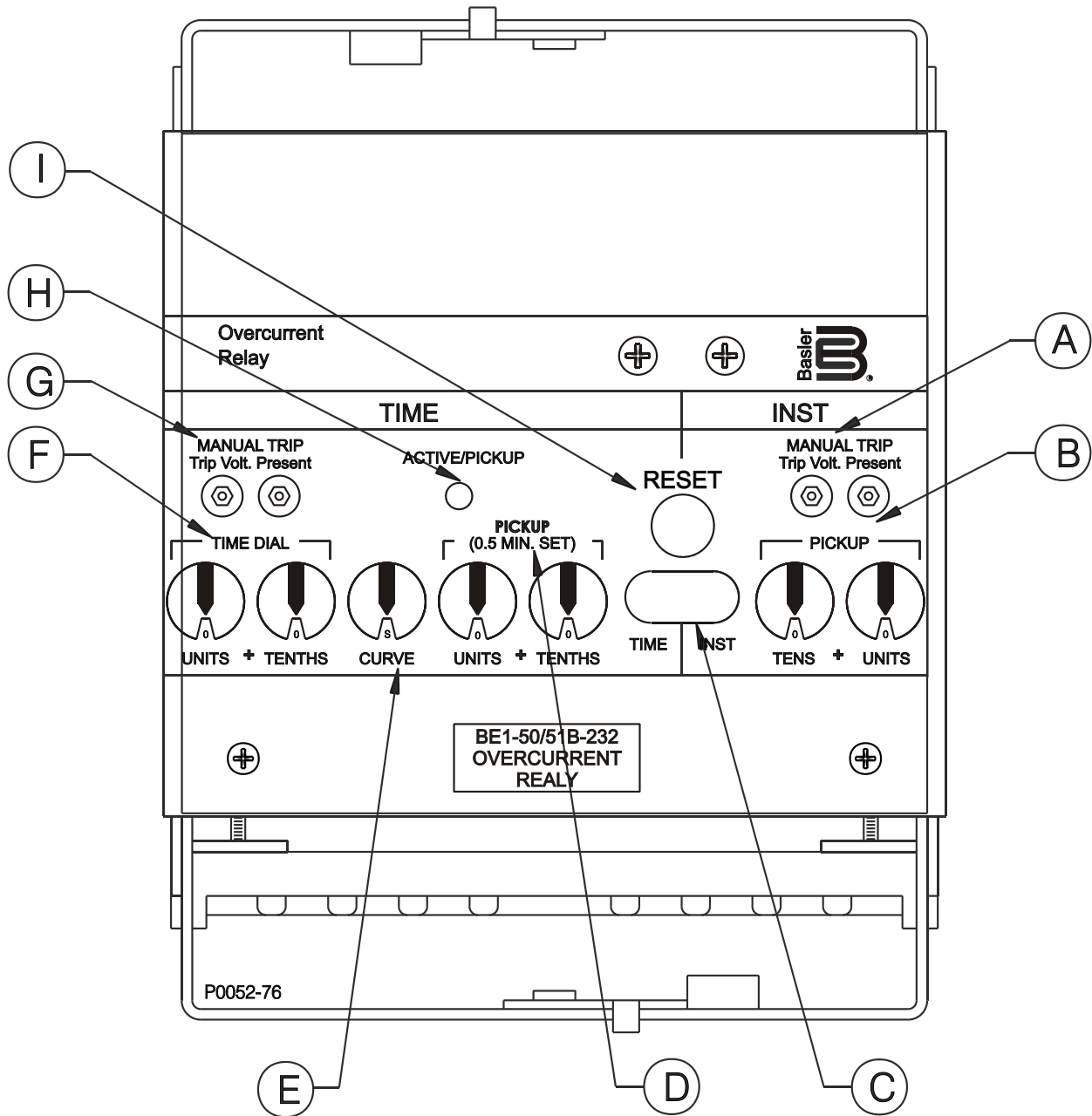

Figure 2-1. Front Panel Controls and Indicators

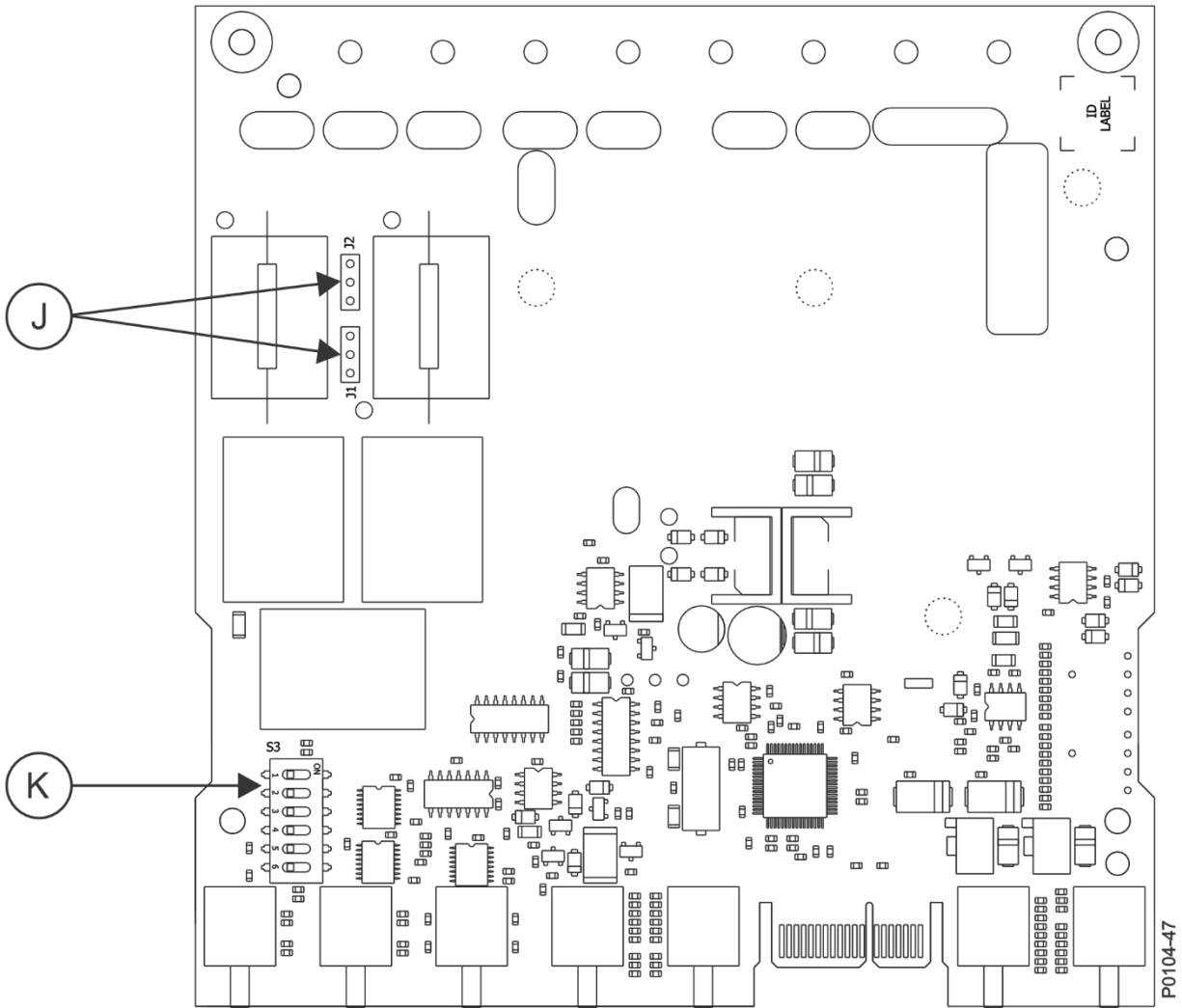

Figure 2-2. Location of Jumpers and Switch

Table 2-1. BE1-50/51B-232 Controls and Indicators (Refer to Figures 2-1 and 2-2)

Locator	Control or Indicator	Function
A	INST MANUAL TRIP Test Points	When shorted, the test points (jacks) provide a secure means to manually trip the controlled breaker. Jacks accept a standard 0.08-inch diameter phone tip plug.
B	INST PICKUP Selectors	Two switches (TENS and UNITS) to select pickup current in amperes. Changing switch selectors while the relay is in service may cause tripping.
C	Targets	Red target indicators latch when the trip circuit current is greater than 0.2 amperes. One target each for TIME and INST.
D	TIME PICKUP Selectors	Two switches (UNITS and TENTHS) to select pickup current in amperes. Changing switch selectors while the relay is in service may cause tripping.
E	CURVE Selector	Ten-position selector switch to select one of nine inverse functions or one fixed time function.

F	TIME DIAL Selectors	Two selector switches (UNITS and TENTHS) to select the desired characteristic curve. A setting of 0.0 results in instantaneous operation without any intentional delay. A setting of 9.9 corresponds to the typical time provided by an electromechanical relay at its maximum dial setting.
G	TIME MANUAL TRIP Test Points	When shorted, the test points provide a secure means to manually trip the controlled breaker. Jacks accept a standard 0.08-inch diameter phone tip plug.
H	ACTIVE/PICKUP LED	Red LED indicates sensed current has exceeded the TIME PICKUP setting. LED turns from red to green when sensed current falls below 95% of pickup setting. When the LED is green, the relay is active but has not picked up.
I	Target RESET Button	Linkage extends through back of front cover to reset both gravity-latched target indicators.
J	Target Operating Current Jumpers	Two user-adjustable jumpers control the range of trip circuit current required to operate the time overcurrent (51) and instantaneous overcurrent (50) target indicators. Jumper J1 sets the minimum current range for the 51 target indicator, and J2 sets the minimum current range for the 50 target indicator. Two jumper positions are possible: across pins 1 and 2 or across pins 2 and 3. Installing a jumper across pins 1 and 2 gives a minimum operating current of 0.9 to 2.25 A. Installing a jumper across pins 2 and 3 gives a minimum operating current of 80 to 200 mA.
K	SW3-1	SW3-1 provides an additional instantaneous delay of 0.2 second when closed (ON). Closing both SW3-1 and SW3-2 provides an additional instantaneous delay of 0.3 second.
	SW3-2	SW3-2 provides an additional instantaneous delay of 0.1 second when closed (ON). Closing both SW3-2 and SW3-1 provides an additional instantaneous delay of 0.3 second.
	SW3-3	SW3-3 provides selection of GE-IAC-type curves or ABB-type curves. Closing switch SW3-3 (ON) selects GE-IAC-type curves (refer to Table 1-3). Opening switch SW3-3 (OFF) selects ABB-type curves (refer to Table 1-2).
	SW3-4	SW3-4 provides selection of either instantaneous or integrating reset characteristics. Closing SW3-4 (ON) selects integrating reset characteristics. Opening SW3-4 (OFF) selects instantaneous reset characteristics.
	SW3-5	Not used.
	SW3-6	Not used.



3 • Functional Description

BE1-50/51B-232 Overcurrent Relays are microprocessor-based non-directional relays that measure ac current to provide secure and reliable instantaneous and time overcurrent protection for power systems.

Functional Description

Sensing Input

Single-phase ac current from system current transformers (CT) is brought into the Overcurrent Relay at terminals 5 and 6. Refer to Figure 3-1 to follow the functional description. The input current is applied to internal power and signal CTs.

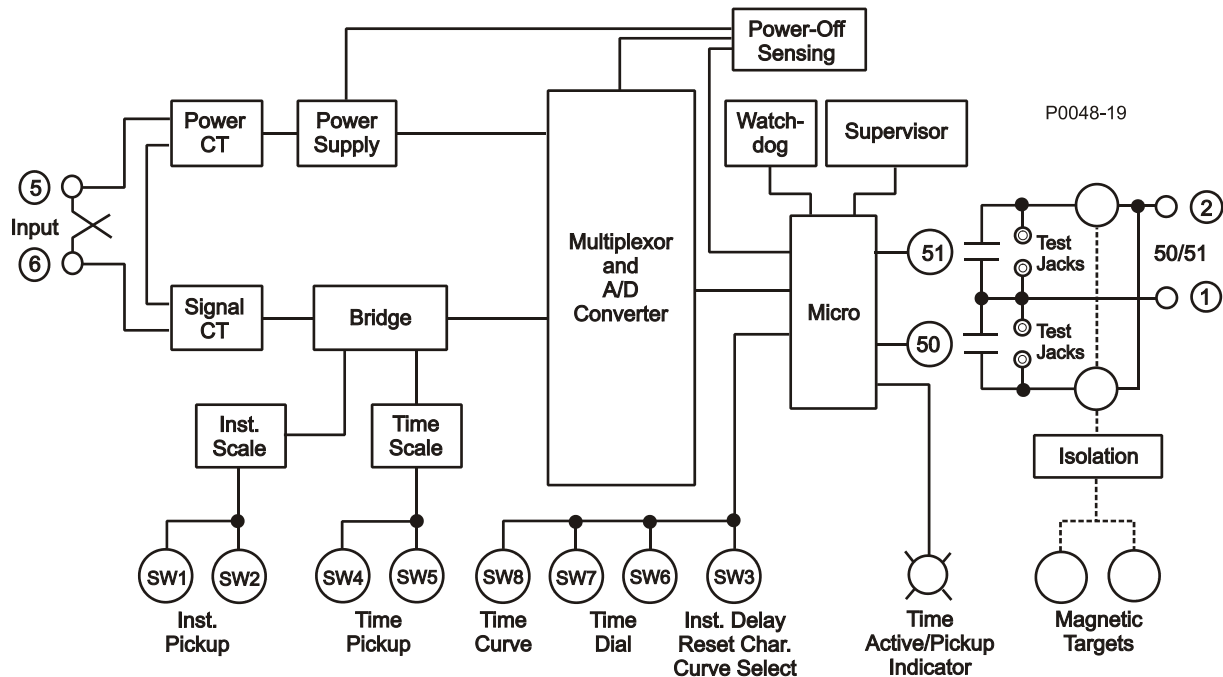

Figure 3-1. Functional Block Diagram

Power Supply

Current from the power CT is rectified, filtered, and supplied to all relay internal circuitry for operating power. A precision +5 Vdc supply also serves as a reference for automatic calibration.

Instantaneous Signal

Current from the signal CT is rectified and applied to the instantaneous scaling resistors controlled by the INST PICKUP selector switches. The analog voltage of the instantaneous input signal developed across the scaling resistors is filtered and applied to the multiplexor (MUX).

Time Signal

Current from the signal CT is also rectified and applied to the time scaling resistors controlled by the TIME PICKUP selector switches. The analog voltage of the time input signal is also filtered and applied to the multiplexor.

Microprocessor

Operating power from the power supply is applied to the microprocessor supervisor circuit. When the microprocessor is active and executing code, the ACTIVE/PICKUP LED is green. When the input current falls below an acceptable level, the supervisor circuit interrupts the microprocessor, halts further operation, and turns OFF the ACTIVE/PICKUP LED. A microprocessor watchdog feature resets the microprocessor program when the program flow is interrupted.

Information from the TIME DIAL selector switches, the TIME CURVE selector switch, INST DELAY switches, and RESET CHAR switch is also applied to the microprocessor. The microprocessor uses these inputs to set the operating parameters.

When the microprocessor is ready for analog information from the multiplexor, microprocessor control signals cause the multiplexor to route the desired input through to the output. The output is converted from an analog value to a digital value and applied to the microprocessor.

The microprocessor performs the program operations based on the inputs and the internal software program. When the sensed current exceeds the TIME PICKUP setting, the ACTIVE/PICKUP LED turns from green to red. The 50/51 contact is closed in accordance with the TIME characteristic equation or if the sensed current exceeds the INST PICKUP setting.

Power-Off Sensing

Power-off sensing circuits measure the voltage across a capacitor at power-down and at power-up. These circuits determine how long power has been removed based on the difference voltage and the circuit RC time constant. This provides information for the integrating reset function even when power has been entirely removed.

Outputs

Instantaneous and Timed

System circuit breakers controlled by the output contacts can be manually tripped by applying a short across the TIME or INST MANUAL TRIP front panel test points. Current flow in the trip circuit is indicated by the operation of the target. The targets will not operate without adequate operating power for the relay.

Warning!

Trip circuit voltage is present at the front panel test points. When shorting the test points, use insulated jumpers to avoid contact with these voltages.

Target Indicators

Gravity-latched, manually-reset, current-operated target indicators are provided for the time overcurrent (51) trip output and the instantaneous overcurrent A (50) trip output. The level of trip circuit current required to operate each target is individually controlled by a circuit board jumper. The minimum operating current range can be set for 80 to 200 milliamperes or 0.9 to 2.25 amperes. See Section 2, *Controls and Indicators* for jumper locations and function assignments.

4 • Installation

When not shipped as part of a control or switchgear panel, the relays are shipped in sturdy cartons to prevent damage during transit. Immediately upon receipt of a relay, check the model and part number against the requisition and packing list to see that they agree. Visually inspect the relay for damage that may have occurred during shipment. If there is evidence of damage, immediately file a claim with the carrier and notify the Regional Sales Office, or contact the Sales Representative at Basler Electric, Highland, Illinois.

Proper operation of the relay may be confirmed by performing the operational test procedure of Section 5. If the relay won't be installed immediately, store the relay in its original shipping carton in a moisture- and dust-free environment.

Mounting

Relay outline dimensions and panel drilling diagrams are shown in Figures 4-1 through 4-4. Dimensions in parentheses are in millimeters.

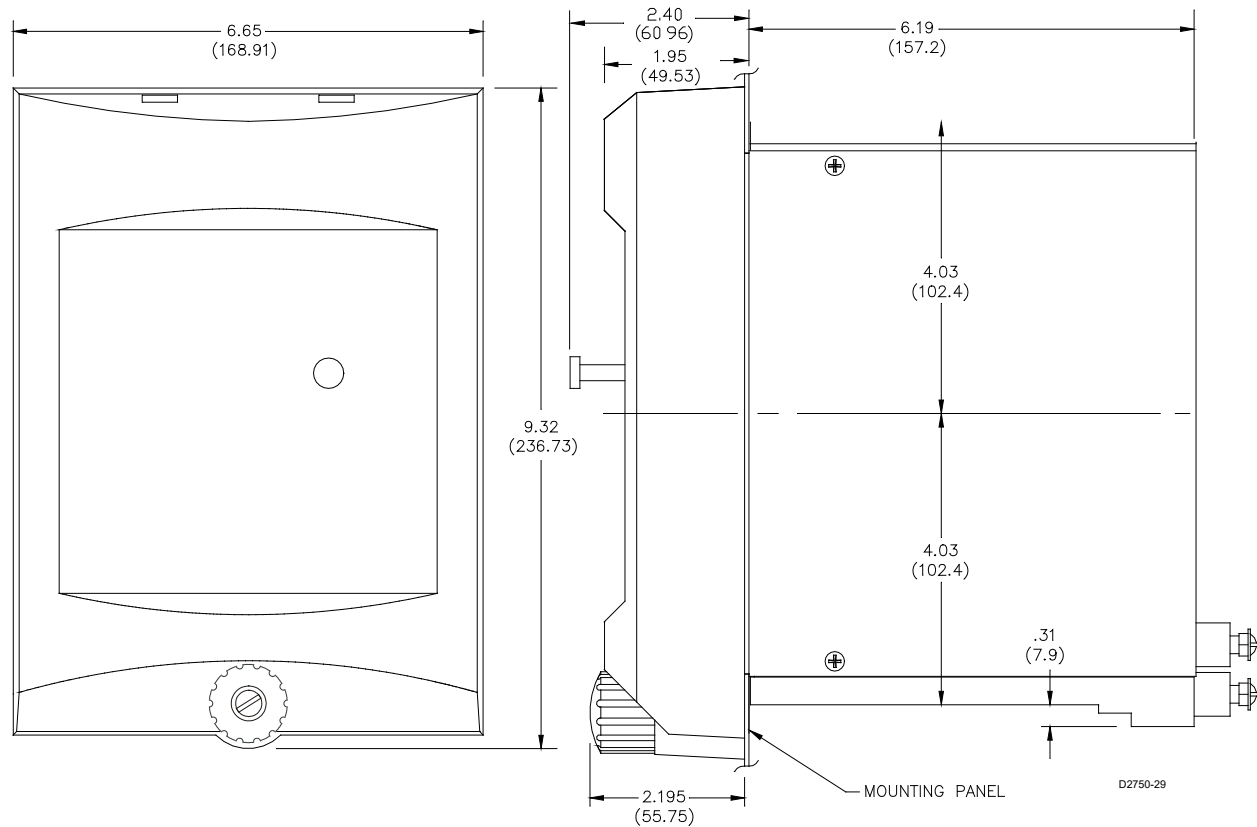

Figure 4-1. Outline Dimensions for S1 Case, Semi-Flush Mounting

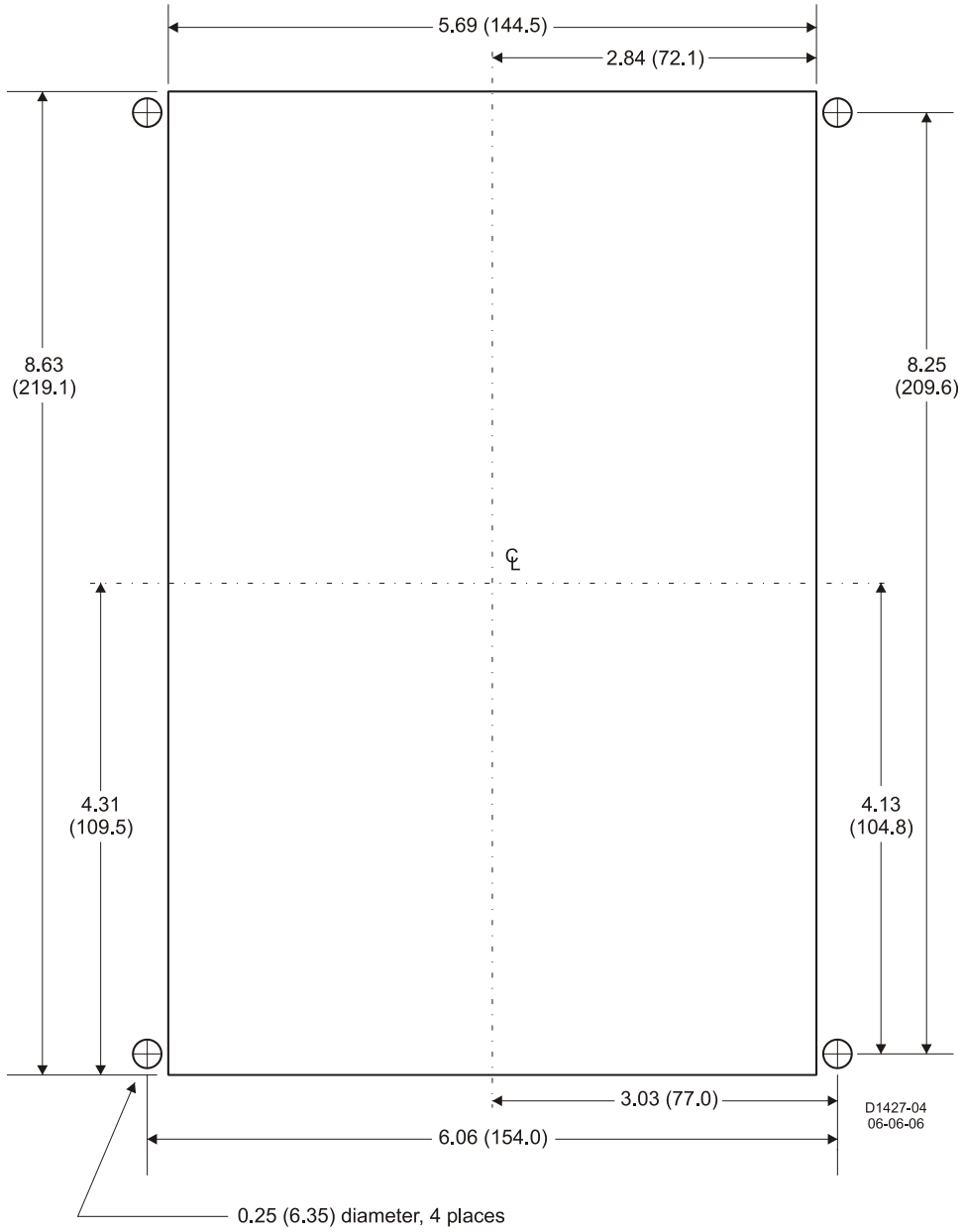

Figure 4-2. Panel Drilling Diagram for S1 Case, Semi-Flush Mounting

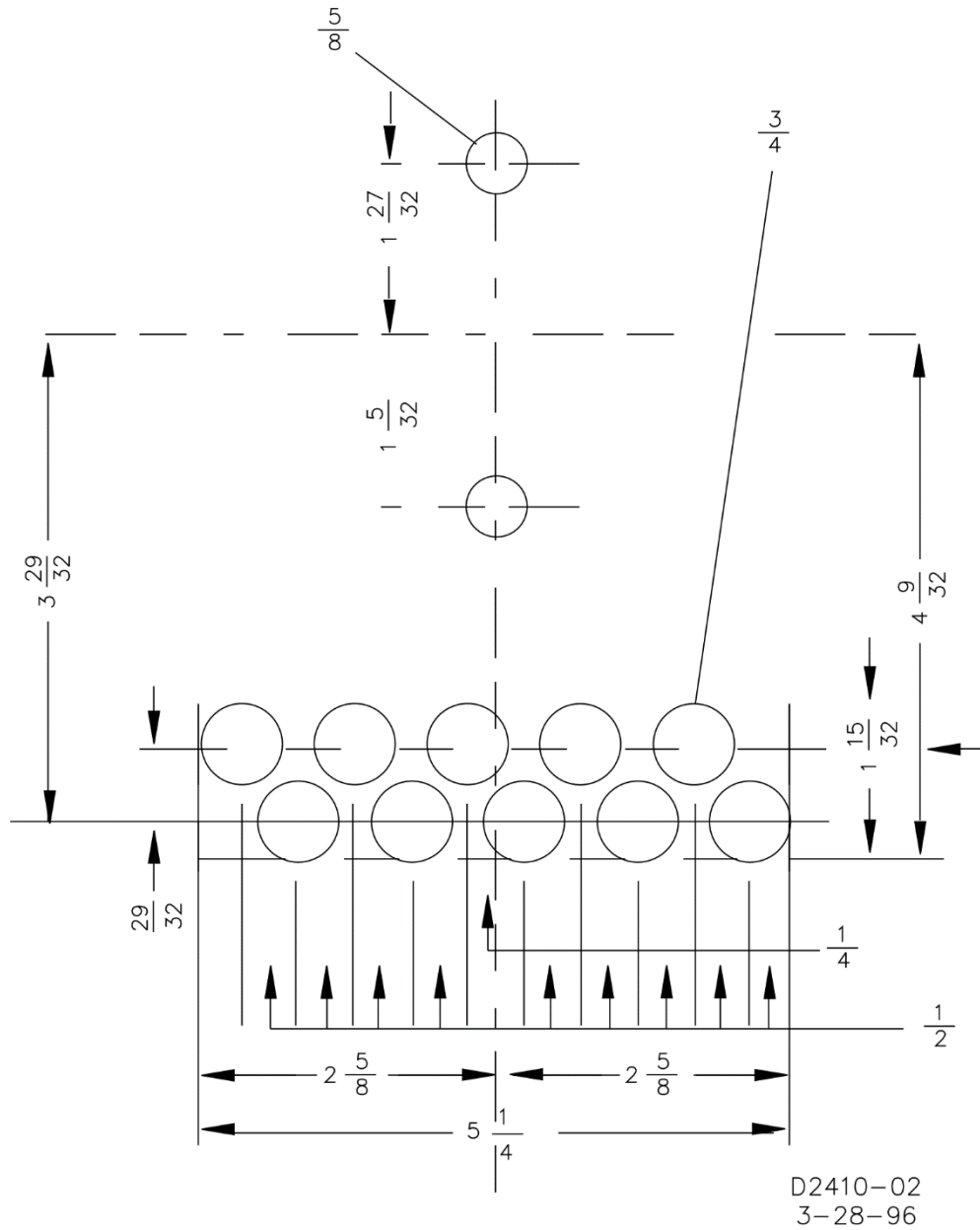
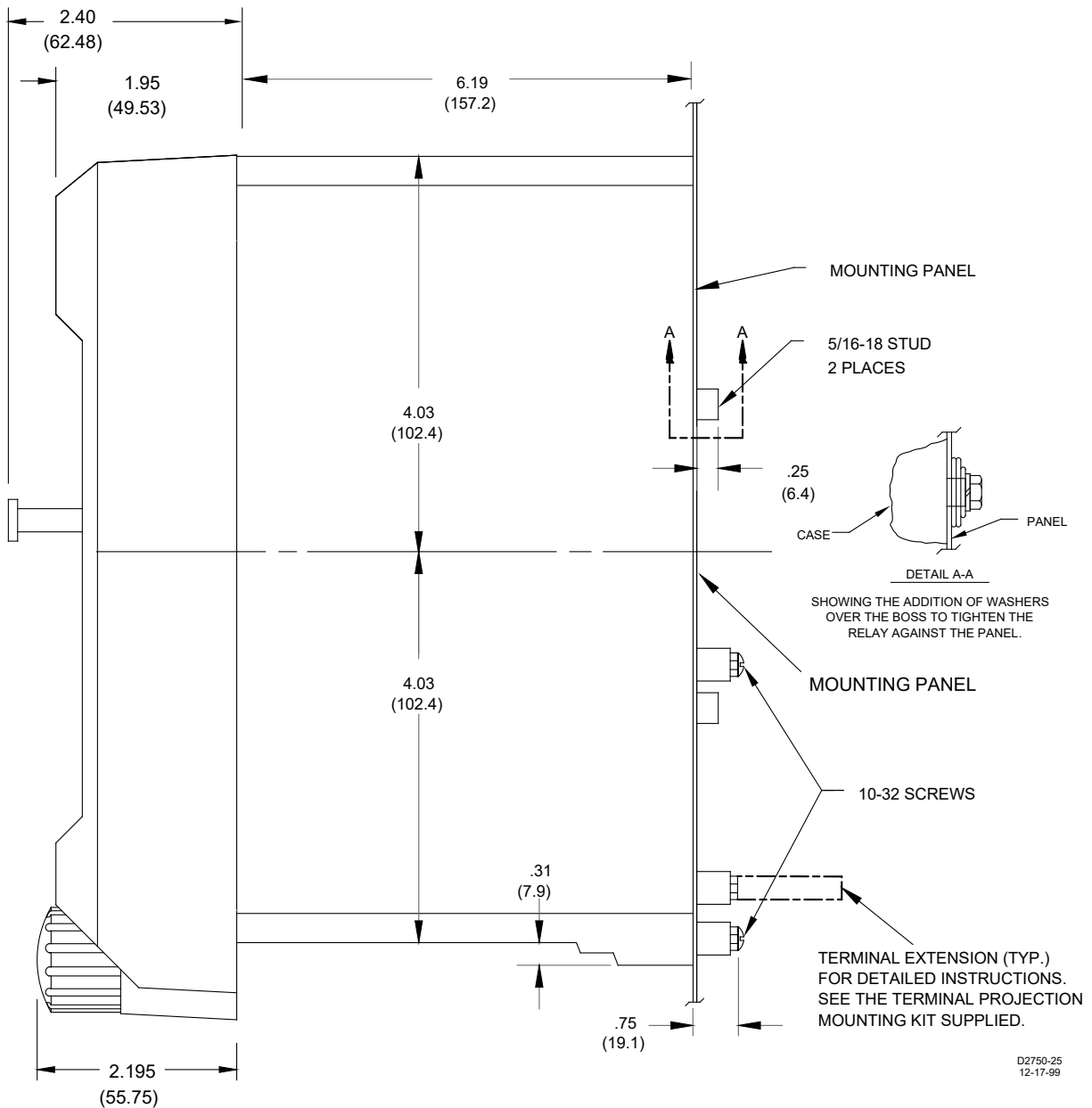

Figure 4-3. Panel Drilling Diagram for S1 Case, Projection Mounting



NOTE: PROJECTION MOUNT USES WASHERS OVER THE BOSSES AS SHOWN IN THIS ILLUSTRATION.

Figure 4-4. Panel Drilling Diagram for S1 Case, Side View, Projection Mounting

Factory Settings

Factory settings for the internal switches of SW3 are as follows:

- SW3-1 — OFF (0.0 additional fixed delay for the instantaneous element)
- SW3-2 — OFF (0.0 additional fixed delay for the instantaneous element)
- SW3-3 — ON (General Electric IAC type characteristic curves)
- SW3-4 — ON (Integrating reset characteristics)
- SW3-5 — Not used
- SW3-6 — Not used
- J1 pins 2-3 — 50-A minimum target operating current of 80 to 200 mA
- J2 pins 2-3 — 51 minimum target operating current of 80 to 200 mA

Application Coordination

In a typical application coordination scheme, a BE1-50/51B-232 is being used to provide primary protection for a radial distribution feeder. An electromechanical overcurrent relay with extremely inverse timing provides protection for the transformer and bus. To improve coordination with the electromechanical relay, the BE1 relay with integrating reset characteristic has the time characteristic curve E (extremely inverse) selected (SW3-3 set to OFF) and the TIME DIAL set to 2.0. The feeder reclosing relay is set for two reclose attempts at 3 and 15 seconds after the initial trip. If a permanent fault occurs (magnitude ten times pickup), calculate the feeder breaker trip time for each of the three operations. Refer to Section 6 for characteristic curve constants.

From the time characteristic curve equation.

$$\begin{aligned}
 T_{\text{Trip}} &= \frac{AD}{M^N - C} + BD + K \\
 &= \frac{7.7624 \times 2}{10^{2.0938} - 1} + (0.02758 \times 2) + 0.028 \\
 &= \frac{15.5248}{124.10806 - 1} + 0.05516 + 0.028 \\
 &= 0.209 \text{ seconds}
 \end{aligned}$$

From the reset characteristic curve equation.

$$\begin{aligned}
 T_{\text{Reset}} &= \frac{RD}{M^2 - 1} \\
 &= \frac{7.75 \times 2}{0^2 - 1} = -15.5 \text{ seconds}
 \end{aligned}$$

$M = 0$ if current goes to zero.

Negative result indicates reset time.

Results: Full trip = 0.209 seconds and full reset = 15.5 seconds if current goes to zero.

In Figure 4-1,

$T_A = 0.209$ seconds (relay was at reset).

$T_B = \text{value} < T_A$ because rewind has not gone to zero.

$T_C = \text{value} < T_A$ because rewind has not gone to zero.

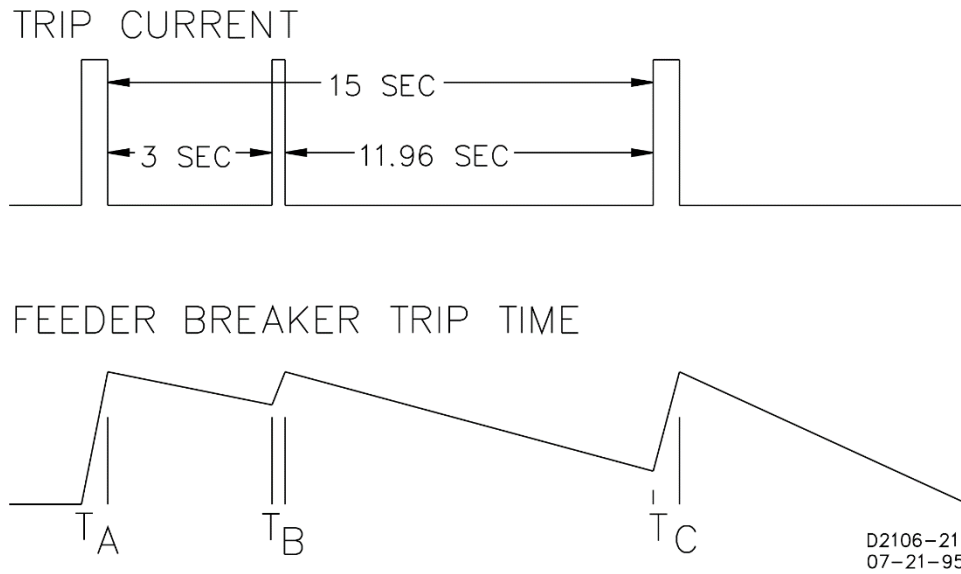

Figure 4-5. Coordination Timing Diagram

Equation for time to trip during rewind (before relay is reset).

$$T_{\text{Trip This Occurrence}} = \frac{(\text{Full Trip})(\text{Rewind Time})}{\text{Full Rewind}}$$

Second Operation

$$T_B = \frac{(0.209)(3)}{15.5}$$

$$T_B = 0.040 \text{ seconds}$$

Third Operation

$$T_C = \frac{(0.209)(11.96)}{15.5}$$

$$T_C = 0.161 \text{ seconds}$$

Connections

Typical ac input and dc control connections are shown in Figures 4-6 and 4-7. Refer to the block diagram in Section 3 for relay internal connections.

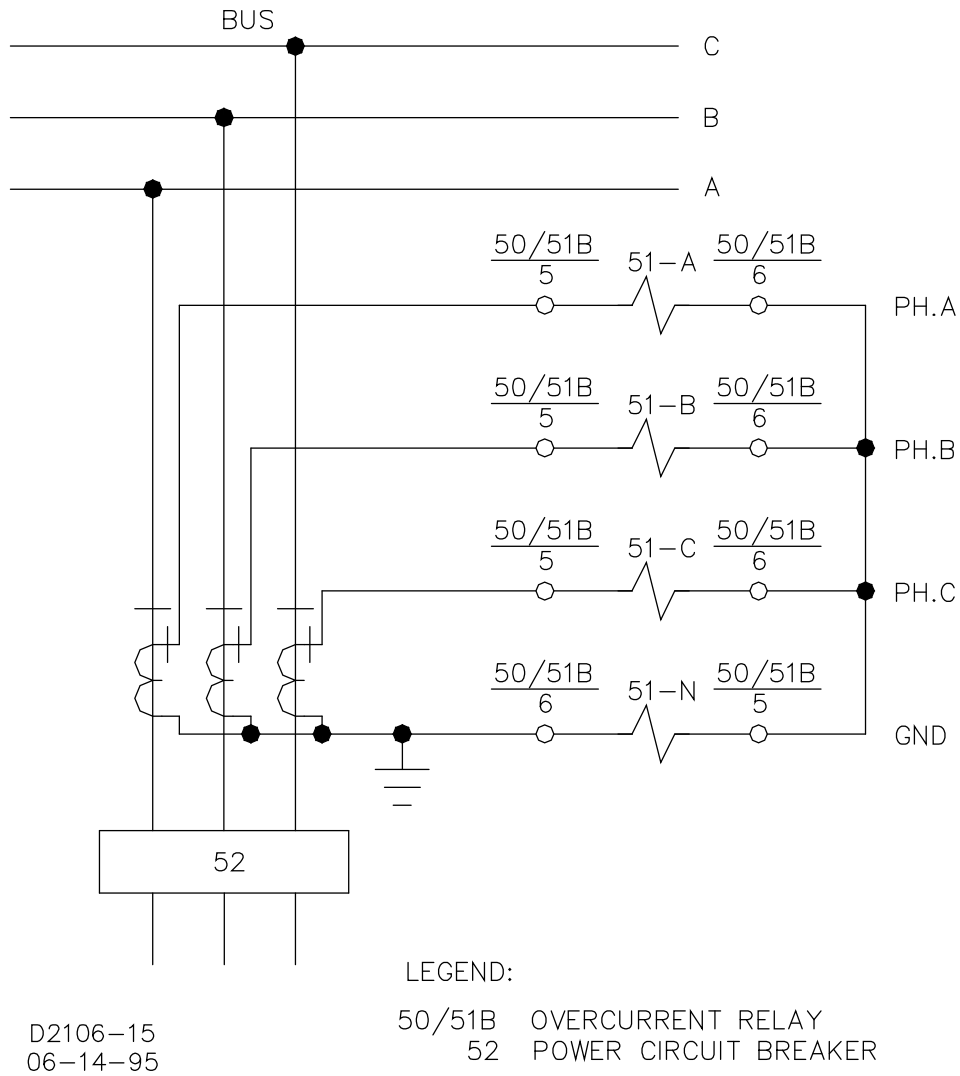

Figure 4-6. AC Input Connections

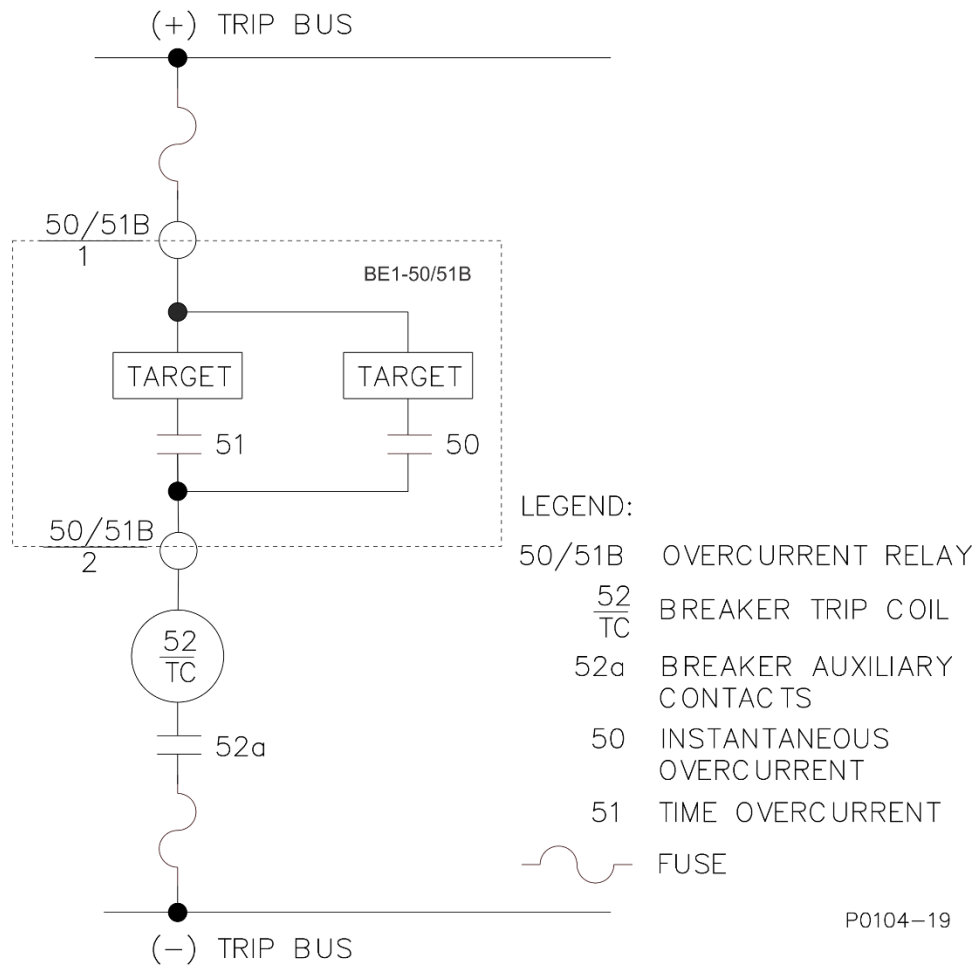

Figure 4-7. DC Control Connections

Maintenance

BE1-50/51B-232 overcurrent relays require no preventive maintenance. However, periodic checks should be performed according to scheduled practices. A recommended periodic test is provided in Section 5. If the relay fails to function properly, contact the Technical Sales Support Department of Basler Electric.

Storage

This device contains long-life aluminum electrolytic capacitors. For devices that are not in service (spares in storage), the life of these capacitors can be maximized by energizing the device for 30 minutes once per year.

5 • Testing

Dielectric testing, operational testing, and periodic testing are described in the following paragraphs.

Dielectric Test

In accordance with IEC 255-5 and IEEE C37.90-1989, one-minute dielectric (high potential) tests may be performed as follows:

All circuits to cradle 2,828 Vdc or 2,000 Vac

Input to output circuits 2,828 Vdc or 2,000 Vac

Output contacts are surge protected.

Operational Test Procedure

The following procedures verify operation of relays BE1-50/51B-232. The test setup of Figures 5-1 and 5-2 are intended primarily as an illustration of the principles involved. Other test setups known to be capable of testing with the stated and implied tolerances (including equipment specifically designed for testing relays) may be used.

Test Equipment Required

- Current source with a range from 0 to 20 Aac (sensing input current)
- AC or DC power source (target operation)
- Timer or counter

Caution

To ensure proper timing during testing, before each test, remove the current from the unit for R times D seconds (refer to Section 6, *Specifications, Integrating Reset* for R and D definitions).

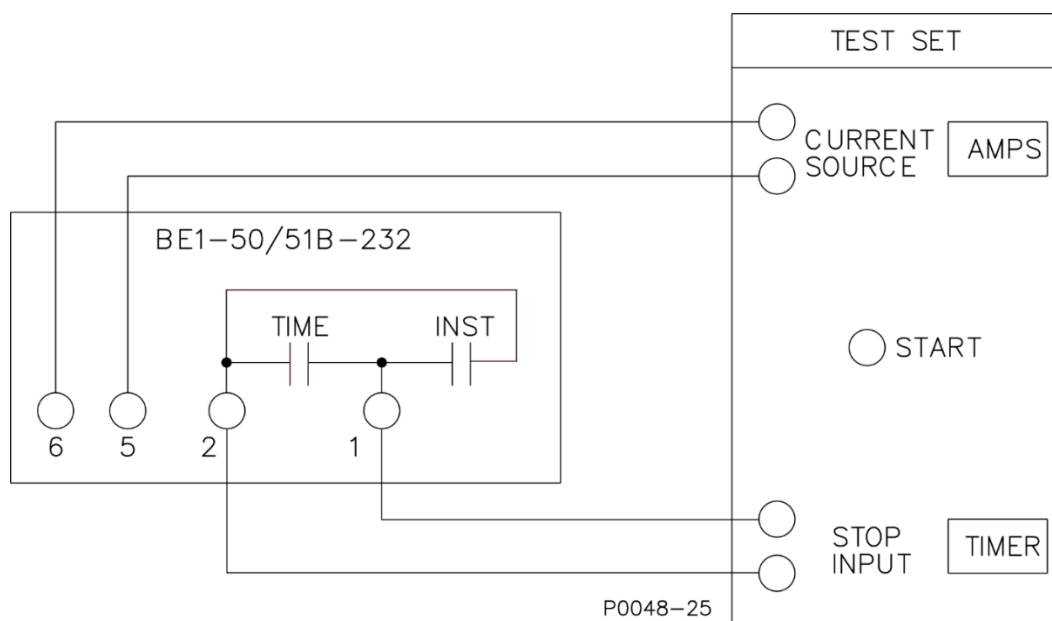

Figure 5-1. Pickup and Timing Test Setup

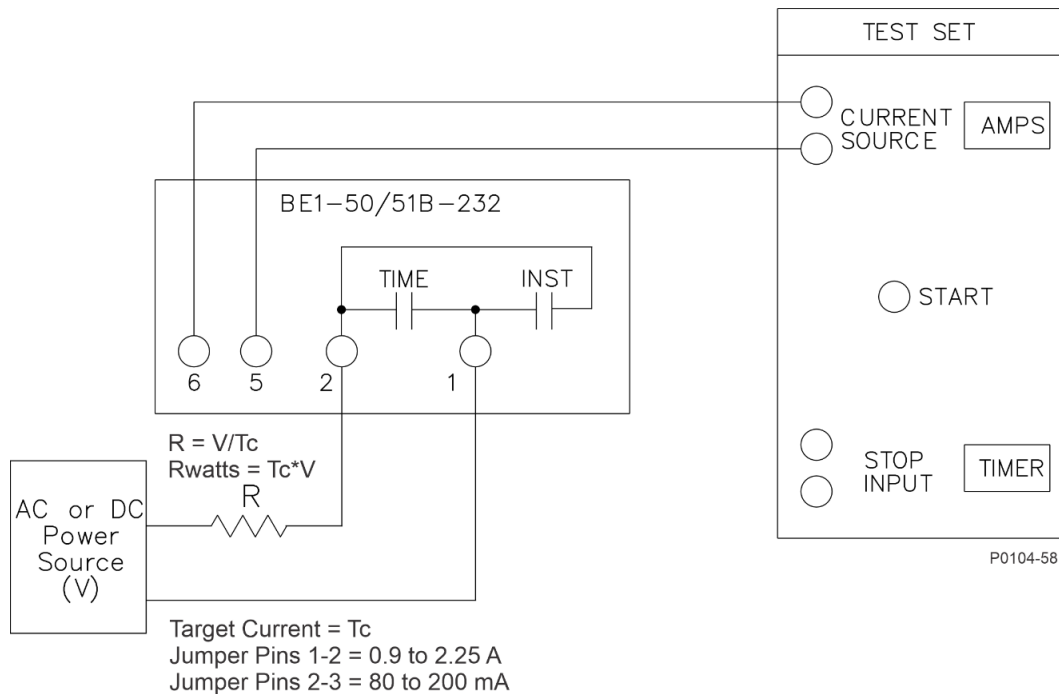

Figure 5-2. Target Operational Test Setup

Note

When testing TIME overcurrent functions, INST PICKUP settings of 00 will affect the calibration of the TIME functions. TIME PICKUP settings of 00 also affect INST functions.

Test Procedure

The following tests are performed to verify functionality of the BE1-50/51B-232 overcurrent relay. The TIME and INST output contact terminals are strapped together. Therefore, it is necessary to disconnect specific wires during the TIME and INST pickup tests. This verifies the proper functionality of the TIME and INST elements.

Note

Observe all applicable electrostatic discharge (ESD) precautions when handling the relay draw-out assembly.

TIME Pickup Test

Perform preliminary setup:

- Connect test setup as shown in Figure 5-1.
- Ensure that SW3 switches are set: SW3-1 to OFF, SW3-2 to OFF, SW3-3 to ON, and SW3-4 to ON.
- Set TIME DIAL to 0.0.
- Set CURVE to S.
- Set TIME PICKUP to 0.5.
- Set INST PICKUP to 90.

- Step 1. Slowly increase current to terminals 5 and 6. PICKUP LED should turn RED at a maximum input current of 0.550 ampere.
- Step 2. Decrease input current until PICKUP LED turns GREEN then OFF.
- Step 3. Set TIME PICKUP to 2.2.
- Step 4. Slowly increase current to terminals 5 and 6. PICKUP LED should change from GREEN to RED at an input current of 2.131 to 2.269 amperes.
- Step 5. Decrease input current until PICKUP LED turns OFF.

INST Pickup Test

Perform preliminary setup:

- Connect test setup as shown in Figure 5-1.
- Ensure that SW3 switches are set: SW3-1 to OFF, SW3-2 to OFF, SW3-3 to ON, and SW3-4 ON.
- Set TIME DIAL to 0.0.
- Set CURVE to S.
- Set TIME PICKUP to 15.9.
- Set INST PICKUP to 01.

- Step 1. Slowly increase current to terminals 5 and 6. INST contacts should close at an input current of 0.955 to 1.045 amperes.
- Step 2. Decrease input current until INST output contacts open.
- Step 3. Set INST PICKUP to 08.
- Step 4. Slowly increase current to terminals 5 and 6. INST contacts should close at an input current of 7.815 to 8.185 amperes.
- Step 5. Decrease input current until INST output contacts open.

Time Dial Test

Perform preliminary setup:

- Connect test setup as shown in Figure 5-1.
- Ensure that SW3 switches are set: SW3-1 to OFF, SW3-2 to OFF, SW3-3 to ON, and SW3-4 ON.
- Set TIME DIAL to 4.5.
- Set CURVE to S.
- Set TIME PICKUP to 1.0.
- Set INST PICKUP to 90.

- Step 1. Prepare to apply 1.5 amperes input current to terminals 5 and 6 and record the elapsed time from when current is applied until TIME output contacts close.
- Step 2. Apply the current (step from 0 to 1.5 amperes) and record the elapsed time. Elapsed time should be 0.345 to 0.424 seconds. (This tolerance is greater than $\pm 2\%$ because it is the accumulation of both pickup and timing tolerances.)
- Step 3. Remove input current.

Target Test

Perform preliminary setup:

- Connect test setup as shown in Figure 5-2.
- Ensure that SW3 switches are set: SW3-1 to OFF, SW3-2 to OFF, SW3-3 to ON, and SW3-4 ON.
- Set TIME DIAL to 4.5.
- Set CURVE to S.
- Set TIME PICKUP to 1.0.
- Set INST PICKUP to 90.

- Step 1. Apply 5 Aac to terminals 5 and 6 to trip the 51 relay output.
- Step 2. Slowly increase the power source to provide target current and verify that the Time target operates at the level of current determined by the Target Operating Current Jumpers.

The Target Operating Current Jumpers are located on the circuit board and identified as J1 and J2. J1 sets the minimum current range for the 51 target, and J2 sets the minimum current range for the 50 target. A jumper installed across pins 1 and 2 gives a minimum operating current of 0.9 to 2.25 A. A jumper installed across pins 2 and 3 gives a minimum operating current of 80 to 200 mA.

- Step 3. Remove the target and sensing current and reset the target.
- Step 4. Set TIME PICKUP to 15.9 and INST PICKUP to 01.
- Step 5. Apply 5 Aac to terminals 5 and 6 to trip the 50 relay output.
- Step 6. Remove the target and sensing current and reset the target.
- Step 7. Remove input current and reset target.

Manual Trip Test

Perform preliminary setup:

- Connect test setup as shown in Figure 5-2.
- Ensure that SW3 switches are set: SW3-1 to OFF, SW3-2 to OFF, SW3-3 to ON, and SW3-4 ON.
- Set TIME DIAL to 4.5.
- Set CURVE to S.
- Set TIME PICKUP to 1.0.
- Set INST PICKUP to 01.

Warning!

Trip circuit voltage is present at the front panel test points. When shorting the test points, use insulated jumpers to avoid contact with these voltages.

- Step 1. Set power source to provide a target current of 1.0 A or 100 mA according to J1 and J2 positions.
- Step 2. Apply 0.9 ampere input current to terminals 5 and 6. (0.9 ampere provides input power but stays below pickup.)
- Step 3. Connect a jumper between TIME MANUAL TRIP test points. Check that TIME target operates.
- Step 4. Connect a jumper between INST MANUAL TRIP test points. Check that INST target operates.
- Step 5. Reset targets.

Integrating Reset Test

Perform preliminary setup:

- Connect test setup as shown in Figure 5-1.
- Ensure that SW3 switches are set: SW3-1 to OFF, SW3-2 to OFF, SW3-3 to ON, and SW3-4 ON.
- Set TIME DIAL to 9.9.
- Set CURVE to V.
- Set TIME PICKUP to 1.0.
- Set INST PICKUP to 90.

- Step 1. Set power source to provide a target current of 1.0 ampere.
- Step 2. Read all of Step 3 before beginning Step 3.

Step 3. Apply 4.0 amperes input current to terminals 5 and 6. After the unit trips, remove the input current for 29 ± 0.25 seconds, then reapply the 4.0 amperes input current. Record the elapsed time from the re-application of input current to the output retrip.

Result: Elapsed time should be 2.08 ± 0.4 seconds.

Setting the Relay

Select the desired relay settings before putting the relay into service. Changing pickup current settings while the relay is in service may cause tripping.

Periodic Tests

General

All relays should be tested periodically to identify and correct any problems that are found.

Single-phase relays such as the BE1-50/51B-232 are normally used in groups of four (three phase and ground) on the protected circuit. This relay scheme allows each unit to be withdrawn one at a time for testing purposes without losing protection. Only three are required at any one time to sense all types of faults on a grounded wye system. Refer to Figures 5-1 and 5-2 for recommended test setups.

Periodic Test

Periodic testing should consist of the following procedures.

Step 1. Verify that the instantaneous pickup is within $\pm 2\%$ of the value set on the dials. Pickup occurs when the INST output contacts close.

Step 2. Verify that the time pickup is within $\pm 2\%$ of the value set on the dials. Pickup occurs when the LED turns GREEN then RED.

Step 3. Verify that the time to trip for the curve and time dial settings at a multiple of six is the same as the time given on the characteristic curve. Refer to Section 7 for the characteristic curves.

Step 4. Verify that the time to trip for the instantaneous element at a pickup multiple of 2 is not greater than the time given on the instantaneous characteristic curve. Refer to Section 6 for the instantaneous characteristic curve.

Step 5. Verify that the targets operate with one ac ampere of trip current in the trip circuits and that they can be reset using the RESET BUTTON.



6 • Specifications

BE1-50/51B-232 electrical and physical specifications are listed in the following paragraphs.

Current Sensing Input

Continuous Current 14 Aac
One Second Rating 400 Aac

Time Overcurrent (51) Element

Setting the TIME PICKUP control at the minimum pickup setting places the relay in the most sensitive state and may be used as a safety setting.

Pickup

Setting Range 0.5 to 15.9 Aac
Setting Increment 0.1 Aac
Accuracy ±2%, ±25 milliamperes at or above 0.5 ampere setting

Dropout

Dropout occurs at 95% of pickup value.

Timing Range

0.0 to 9.9 seconds in 0.1 second steps

Timing Accuracy

The timing accuracy is the sum of ±1 cycle and ±2% for the range of 2 to 40 times tap and is for a given measured multiple of tap. The timing accuracy is the sum of ±2 cycles and ±2% for the range of 1.3 to 2 times tap and is for a given measured multiple of tap.

Curve Characteristics

Nine inverse time functions and one fixed time function can be selected by the front-panel Curve switch. Characteristic curves for the inverse and definite time functions are defined by the following equation.

$$T_T = \frac{AD}{M^N - C} + BD + K$$

Where:

- T_T = time to trip in seconds
- D = time dial setting
- M = multiple of pickup setting
- A, B, C, N, K = constants for the particular curve

Time characteristic curve constants are listed in Tables 6-1 and 6-2. Constants have been selected to conform to the characteristics of electromechanical relays over a range of pickup multiples from 1.3 to 40. Values of the constants are provided for use in computer relay setting software.

Table 6-1. Time Characteristic Curve Constants with SW3-3 Open (Off)

Curve Type *		Figure Number †	Constants					
BE1	Similar To		A	B	C	N	K	R
S	ABB CO-2	7-1	0.2663	0.03393	1.000	1.2969	0.028	0.500
L	ABB CO-5	7-2	5.6143	2.18592	1.000	1.000	0.028	15.750
D	ABB CO-6	7-3	0.4797	0.21359	1.000	1.5625	0.028	0.875
M	ABB CO-7	7-4	0.3022	0.12840	1.000	0.5000	0.028	1.750
I	ABB CO-8	7-5	8.9341	0.17966	1.000	2.0938	0.028	9.000
V	ABB CO-9	7-6	5.4678	0.10814	1.000	2.0469	0.028	5.500
E	ABB CO-11	7-7	7.7624	0.02758	1.000	2.0938	0.028	7.750
B	BS142-B ‡	7-8	1.4636	0.00000	1.000	1.0469	0.028	3.250
C	BS142-C ‡	7-9	8.2506	0.00000	1.000	2.0469	0.028	8.000
F	None §	N/A	0.0000	1.00000	0.000	0.0000	0.000	1.000

Table 6-2. Time Characteristic Curve Constants with SW3-3 Closed (On)

Curve Type *		Figure Number †	Constants					
BE1	Similar To		A	B	C	N	K	R
S	GE IAC 55	7-10	0.0286	0.0208	1.000	0.9844	0.028	0.0940
L	GE IAC 66	7-11	2.3955	0.00002	1.000	0.3125	0.028	7.8001
D	ABB CO-6	7-3	0.4797	0.21359	1.000	1.5625	0.028	0.8750
M	ABB CO-7	7-4	0.3022	0.12840	1.000	0.5000	0.028	1.7500
I	GE IAC 51	7-12	0.2747	0.1042	1.000	0.4375	0.028	0.8868
V	GE IAC 53	7-13	4.4309	0.0991	1.000	1.9531	0.028	5.8231
E	GE IAC 77	7-14	4.9883	0.0129	1.000	2.0469	0.028	4.7742
B	BS142-B ‡	7-8	1.4636	0.00000	1.000	1.0469	0.028	3.2500
C	BS142-C ‡	7-9	8.2506	0.00000	1.000	2.0469	0.028	8.0000
F	None §	N/A	0.0000	1.00000	0.000	0.0000	0.000	1.0000

Notes for Tables 6-1 and 6-2

* BE1 Curve Types: S: Short Inverse V: Very Inverse
 L: Long Inverse E: Extremely Inverse
 D: Definite Time B: BS142 Very Inverse
 M: Moderately Inverse C: BS142 Extremely Inverse
 I: Inverse F: Fixed Time Delay

† Figure numbers refer to the characteristic curves located in the *Time Characteristic Curves* chapter.

‡ Curves B and C are defined in British Standard BS142 and IEC Standard IEC 255-4.

§ Fixed time delay, adjustable from 0.1 to 9.9 seconds.

Integrating Reset

Reset begins when the current drops below 95% of pickup. Integrating reset simulates the disk reset of electromechanical relays. BE1-50/51B-232 relays provide the integrating reset function even when input current falls to zero.

Integrating reset characteristics are defined by the following equation and shown in Figure 6-1. Equation constants are provided in Tables 6-1 or 6-2.

Integrating Reset Equation:

$$T_R = \frac{RD}{M^2 - 1}$$

Where:

- T_R = Time to reset in seconds
- R = Constant for the particular curve
- D = TIME DIAL setting
- M = Current in multiples of PICKUP setting during reset

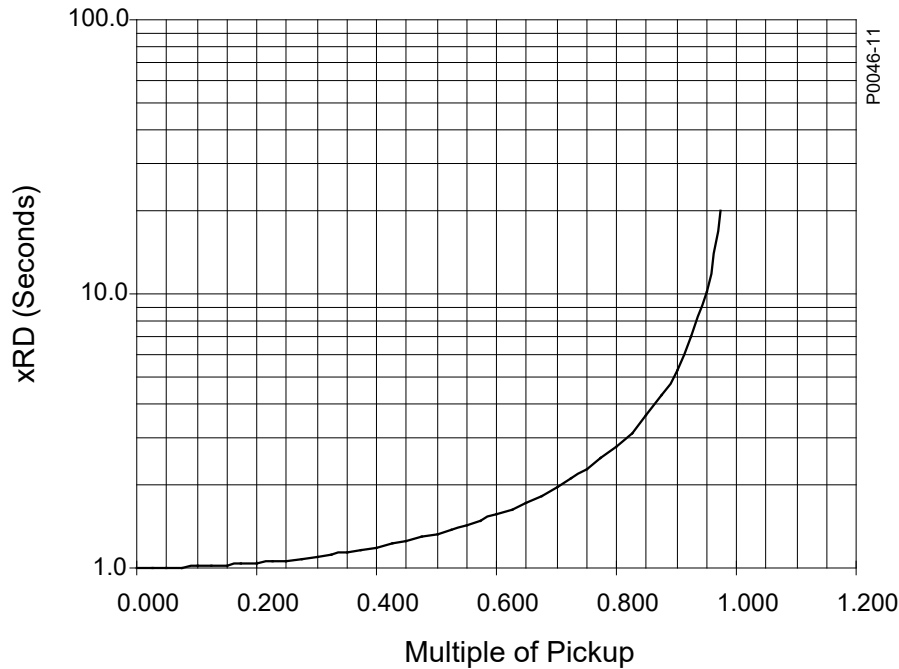

Vertical axis xRD (Seconds) is applicable for all curves and is derived from multiplying the constant R for the curve selected times D (the Time Dial setting).

Figure 6-1. Integrating Reset Characteristic Curve

Instantaneous Overcurrent (50) Element

Setting the INST PICKUP control to the minimum pickup setting places the relay in the most sensitive state and may be used as a safety setting.

Pickup

- Setting Range 1 to 99 Aac
- Setting Increment 1 Aac
- Accuracy ±2%, ±25 milliamperes at or above 1.0 ampere setting

Dropout

Dropout occurs at 95% of pickup value.

Curve Characteristics

Instantaneous characteristic curves are similar to standard electromechanical instantaneous units. However, the time to trip for applications where the initial current through the relay is less than 0.4 ampere may be slightly longer. This may occur on a very lightly loaded circuit or when the relay is providing ground protection and is connected to measure neutral current. Figure 6-2 shows the instantaneous characteristic curves for maximum time to trip.

An additional fixed delay of 0.1, 0.2, or 0.3 second may be added with internal switches SW3-1 and SW3-2. This delay applies to both phase and ground applications. Closing switch SW3-1 provides an additional delay of 0.2 second. Closing switch SW3-2 provides an additional delay of 0.1 second. Closing

both SW3-1 and SW3-2 provides an additional delay of 0.3 second. Section 2 illustrates the location of SW3.

The instantaneous element in BE1-50/51B-232 relays may be set lower than the instantaneous element in ABB relays and still have the same reach. This is because the BE1-50/51B-232 instantaneous element effectively eliminates the fault current transient overreach components. When calculating BE1-50/51B-232 relay instantaneous element settings, calculate the symmetrical value without any adder for transient overreach.

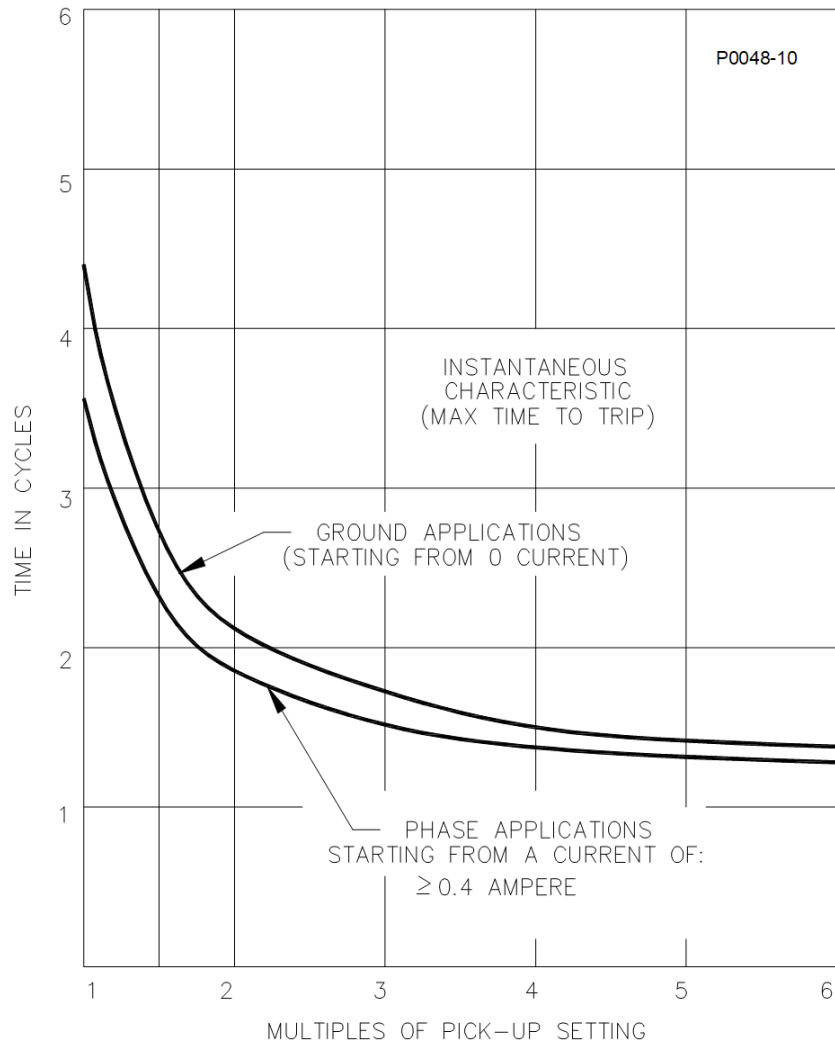

Figure 6-2. Instantaneous Characteristic Curves

Burden

Burden is non-linear. Figure 6-3 illustrates the device burden.

At 0.5 amperes $Z = 4.4 \Omega$

At 5.0 amperes $Z = 0.2 \Omega$

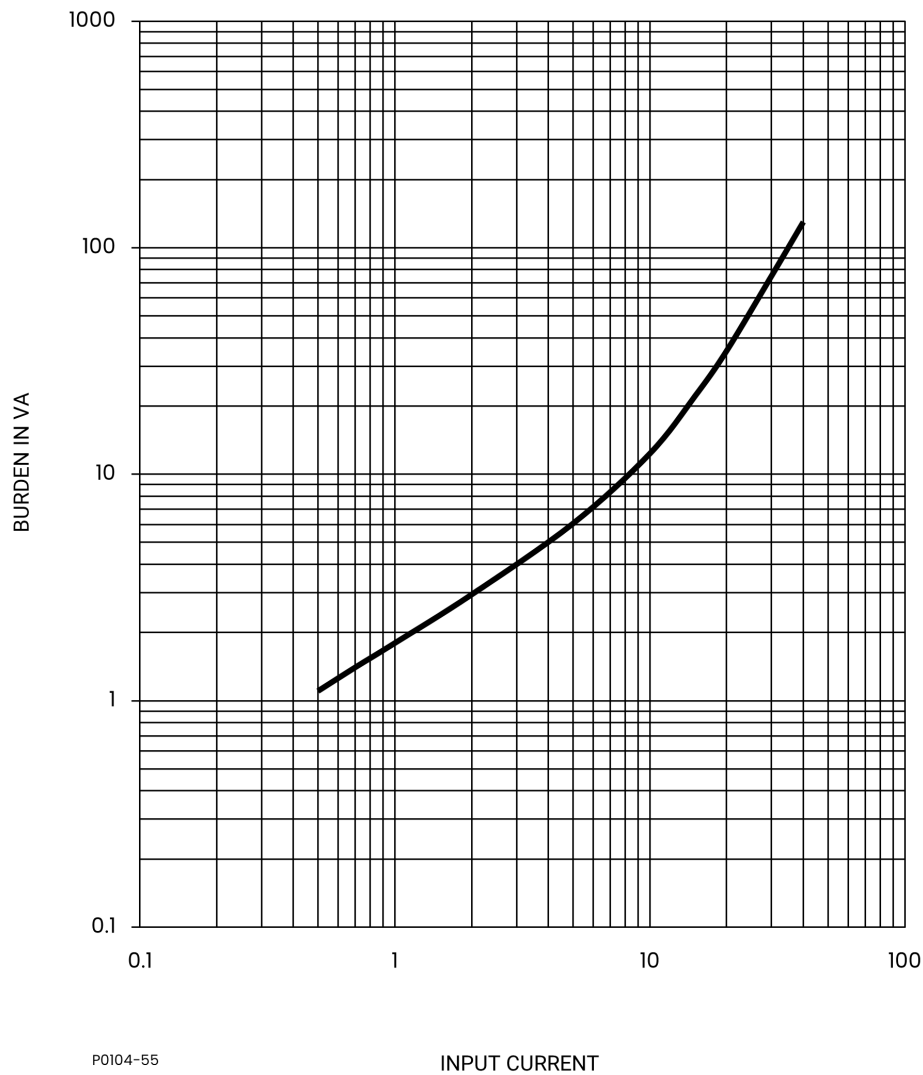

Figure 6-3. Burden Characteristics

Frequency Response

A change of ± 5 Hz from the nominal 60 Hz current causes $<0.5\%$ change in the current required for pickup.

Transient Response

$<10\%$ overreach with system time constants up to 40 ms.

Harmonic Response

Figure 6-4 shows that a relay set for 1-ampere pickup would pick up at 0.96 amperes with a current containing 40% seventh harmonic. This corresponds to a 10:1 rejection ratio. Other conditions may be evaluated in the same manner.

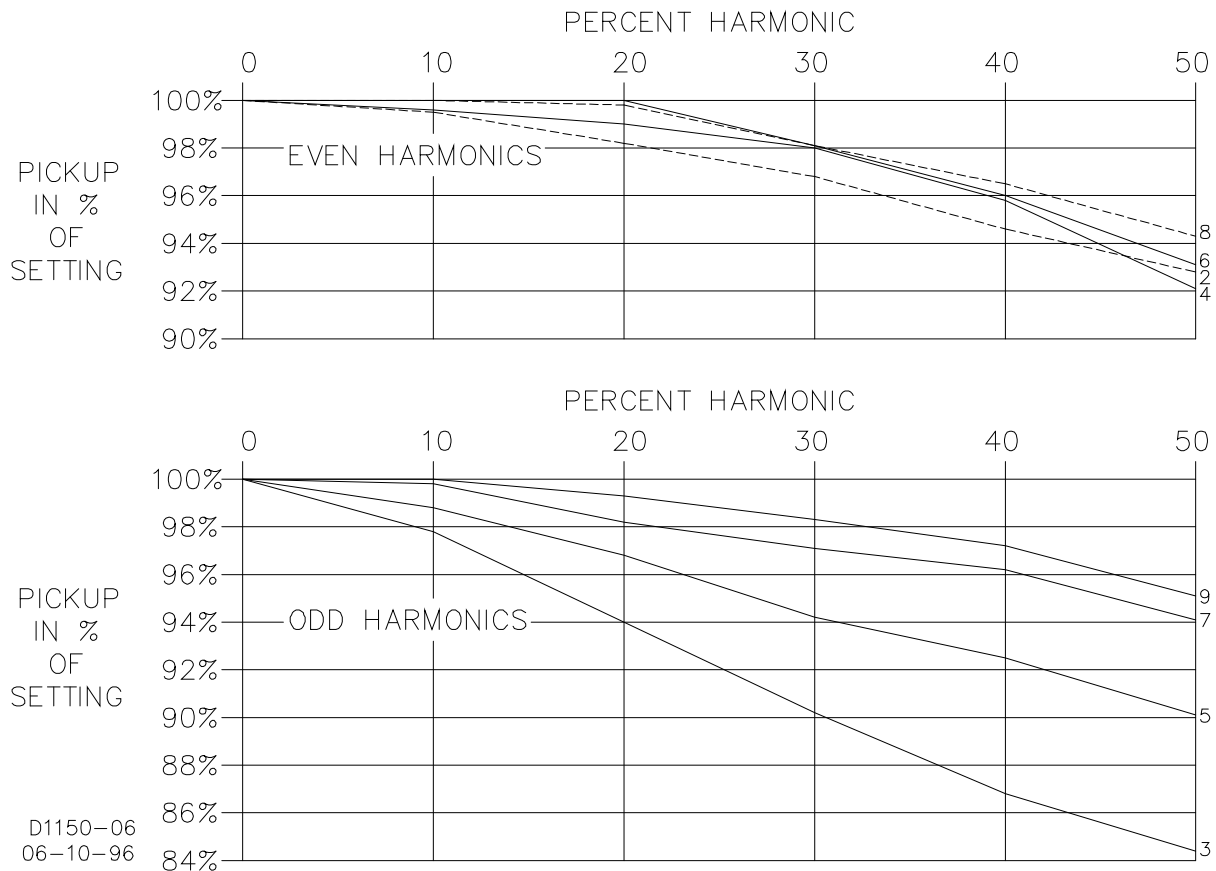

Figure 6-4. Harmonic Rejection

Target Indicators

Gravity latched, manually-reset targets indicate that current of 0.2 amperes or greater was present in the trip circuit. Target coil resistance is less than 0.1 ohms and operate time is less than one millisecond. See *Output Contacts* for maximum current rating. The level of trip circuit current required to operate each target is individually controlled by a circuit board jumper. See Section 2, *Controls and Indicators* for jumper locations and function assignments.

Target Operate Current

Jumper Position—Pins 1 and 2.....Must operate ≥ 2.25 A; must not operate < 900 mA. *

Jumper Position—Pins 2 and 3.....Must operate ≥ 200 mA; must not operate < 80 mA. *

* See *Output Contacts* for the maximum acceptable levels of trip circuit currents.

Output Contacts

Output contacts are surge protected and rated as follows.

Resistive Ratings

120/240 Vac: Make 30 amperes for 0.2 seconds, carry 7 amperes for 2 minutes, 3 amperes continuously, and break 5 amperes.

125/250 Vdc: Make 30 amperes for 0.2 seconds, carry 7 amperes for 2 minutes, 3 amperes continuously, and break 0.3 ampere.

Inductive Ratings

120/240 Vac, 125/250 Vdc: Make and carry 30 amperes for 0.2 seconds, carry 7 amperes for 2 minutes, 3 amperes continuously, and break 0.3 ampere. (L/R = 0.04).

Type Tests

Isolation	IEEE C37.90-2005
Transient Surge	IEEE C37.90.1-2004
Radiated Interference	IEEE C37.90.2-2004
Electrostatic Discharge	IEEE C37.90.3-2006
Vibration	IEC 255-21-1
Shock and Bump	IEC 255-21-2

Environment

Operating Temperature	-40°C to 70°C (-40°F to 158°F)
Storage Temperature	-50°C to 70°C (-58°F to 158°F).

China RoHS

The following table serves as the declaration of hazardous substances for China in accordance with PRC standard SJ/T 11364-2014. The EFUP (Environment Friendly Use Period) for this product is 40 years.

PRODUCT: BE1-50/51B										
零件名称 Part Name	有害物质 Hazardous Substances									
	铅 Lead (Pb)	汞 Mercury (Hg)	镉 Cadmium (Cd)	六价铬 Hexavalent Chromium (Cr ⁶⁺)	多溴联苯 Polybrominated Biphenyls (PBB)	多溴二苯醚 Polybrominated Diphenyl Ethers (PBDE)	邻苯二甲 酸二丁酯 Dibutyl Phthalate (DBP)	邻苯二甲 酸丁苄酯 Benzyl butyl phthalate (BBP)	邻苯二甲 酸二酯 Bis(2- ethylhexyl) phthalate (BEHP)	邻苯二甲 酸二异丁 酯 Diisobutyl phthalate (DIBP)
金属零件 Metal parts	X	O	X	O	O	O	O	O	O	O
聚合物 Polymers	O	O	O	O	O	X	O	O	O	O
电子产品 Electronics	X	O	X	O	O	O	O	O	O	O
电缆和互连 配件 Cables & interconnect accessories	X	O	O	O	O	O	O	O	O	O
绝缘材料 Insulation material	O	O	O	O	O	O	O	O	O	O

本表格依据 SJ/T11364 的规定编制。

O: 表示该有害物质在该部件所有均质材料中的含量均在 GB/T 26572 规定的限量要求以下。

X: 表示该有害物质至少在该部件的某一均质材料中的含量超出 GB/T 26572 规定的限量要求。

This form was prepared according to the provisions of standard SJ/T11364.

O: Indicates that the hazardous substance content in all homogenous materials of this part is below the limit specified in standard GB/T 26252.

X: Indicates that the hazardous substance content in at least one of the homogenous materials of this part exceeds the limit specified in standard GB/T 26572.

Physical

Case Size:	S1 (Refer to Section 4, <i>Installation</i> for case dimensions.)
Weight:	6.1 lb (2.77 kg)



7 • Time Characteristic Curves

Figures 7-1 through 7-14 illustrate the time characteristic curves that are programmed into the nonvolatile memory of this relay.

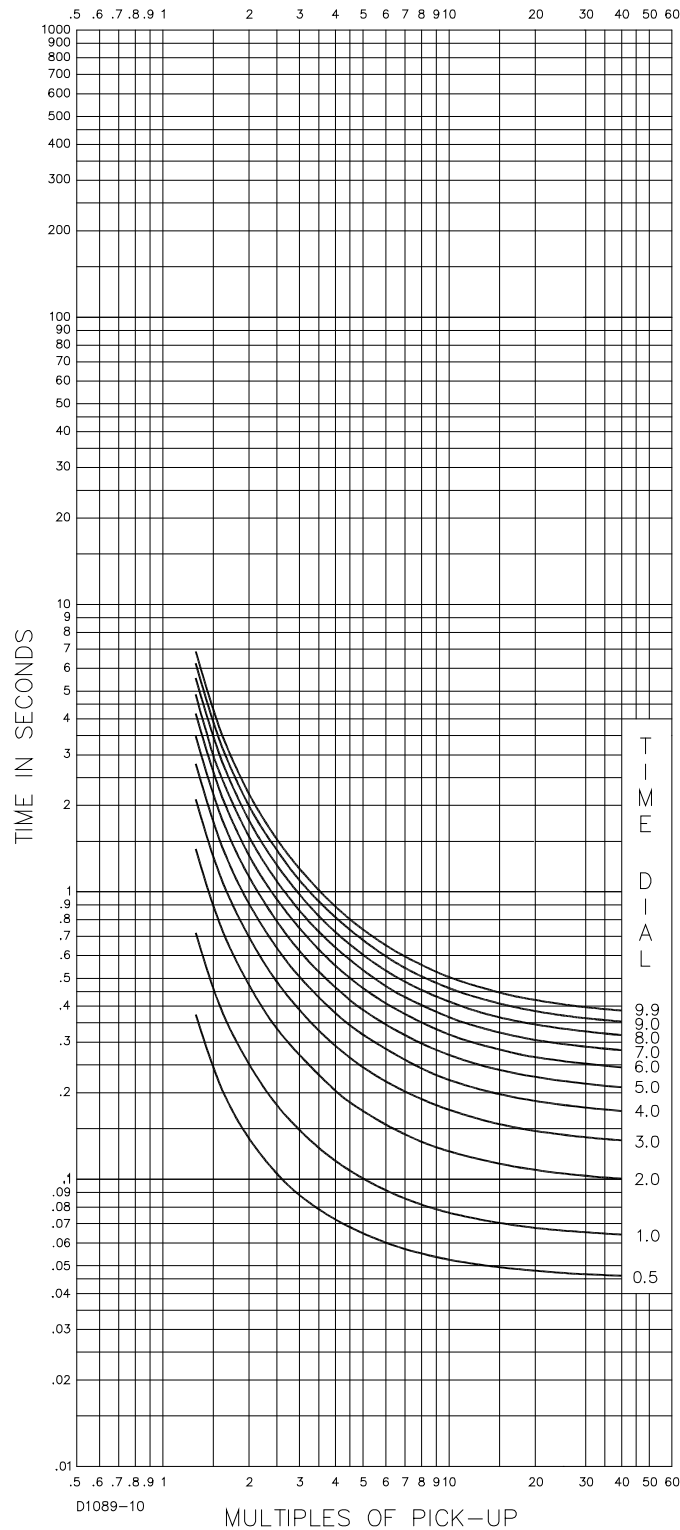

Figure 7-1. Time Characteristic Curve, S-Short Inverse (SW3-3 OFF, Similar to ABB CO-2)

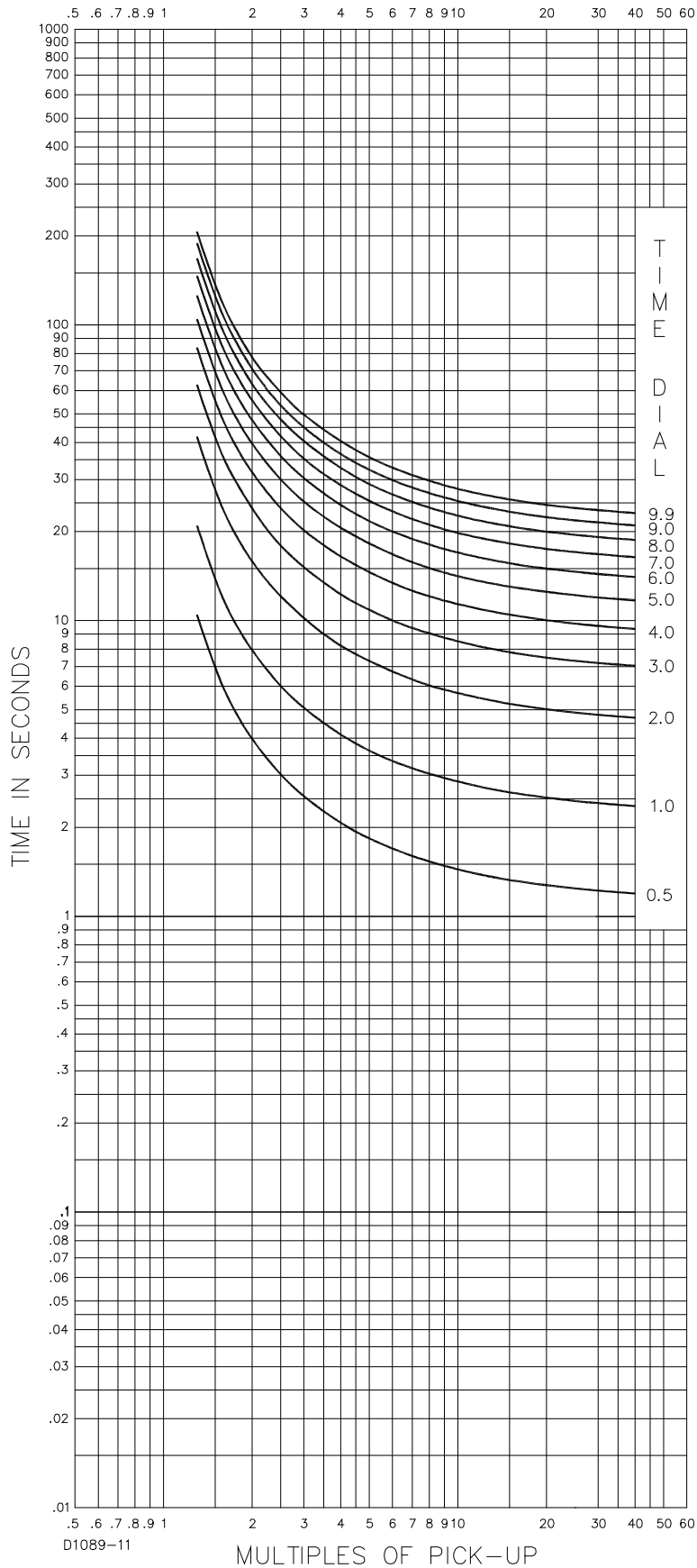

Figure 7-2. Time Characteristic Curve, L-Long Inverse (SW3-3 OFF, Similar to ABB CO-5)

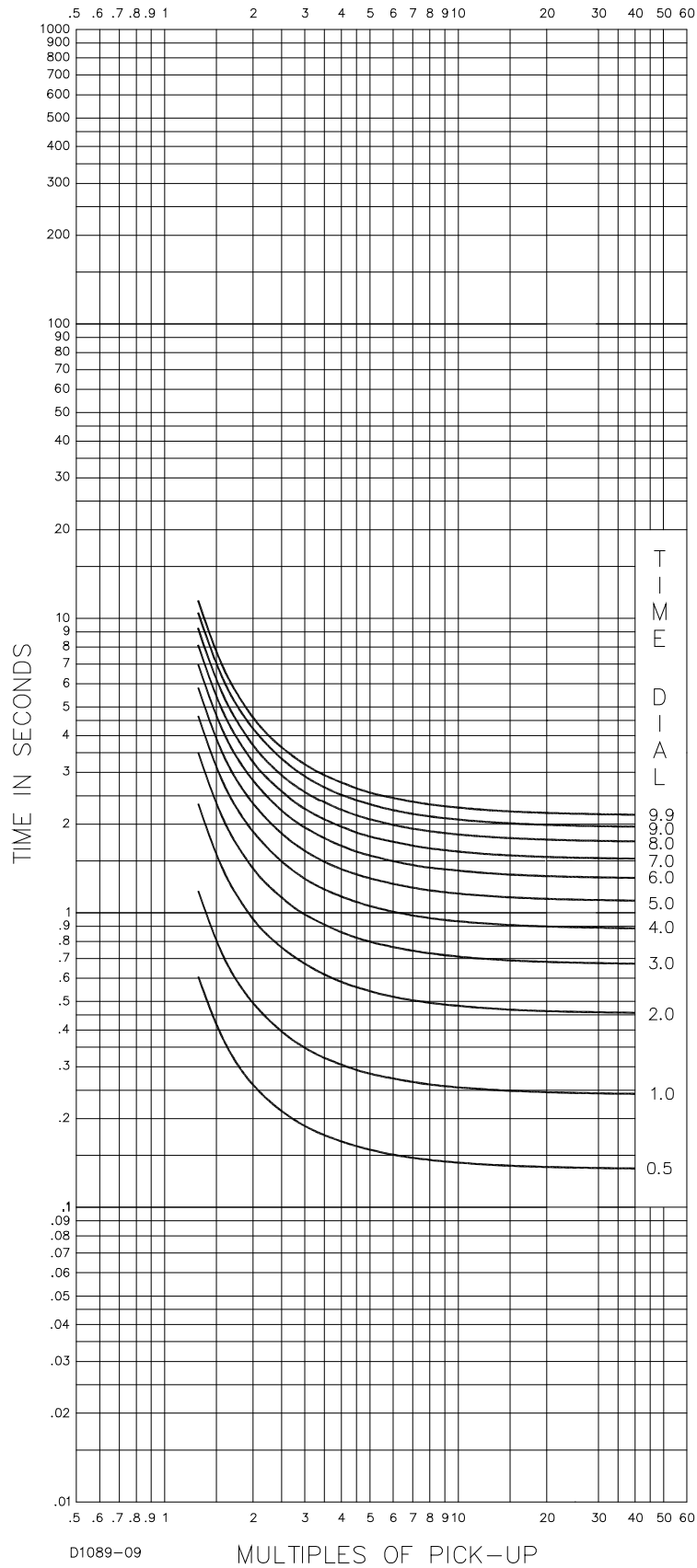

Figure 7-3. Time Characteristic Curve, D-Definite Time (Similar to ABB CO-6)

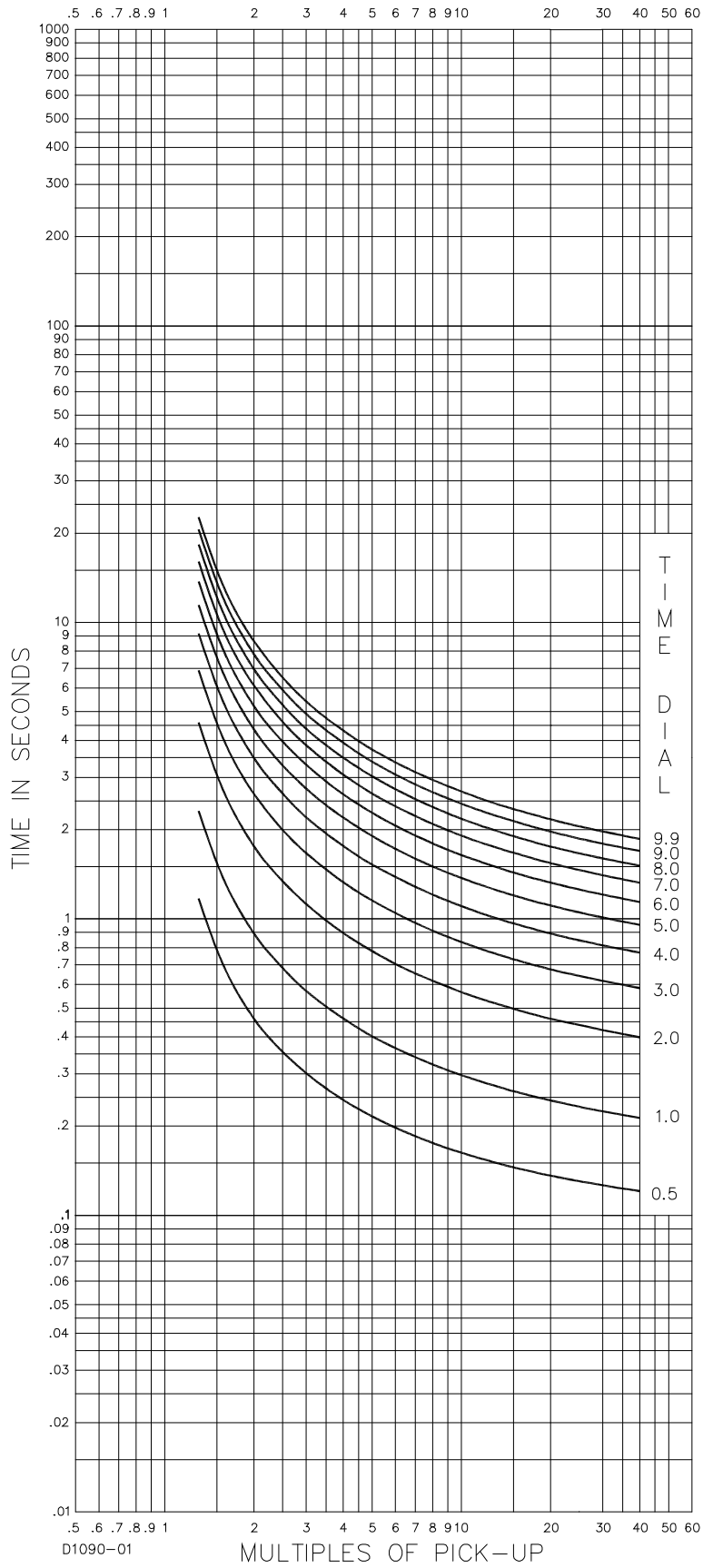

Figure 7-4. Time Characteristic Curve, M-Moderately Inverse (Similar to ABB CO-7)

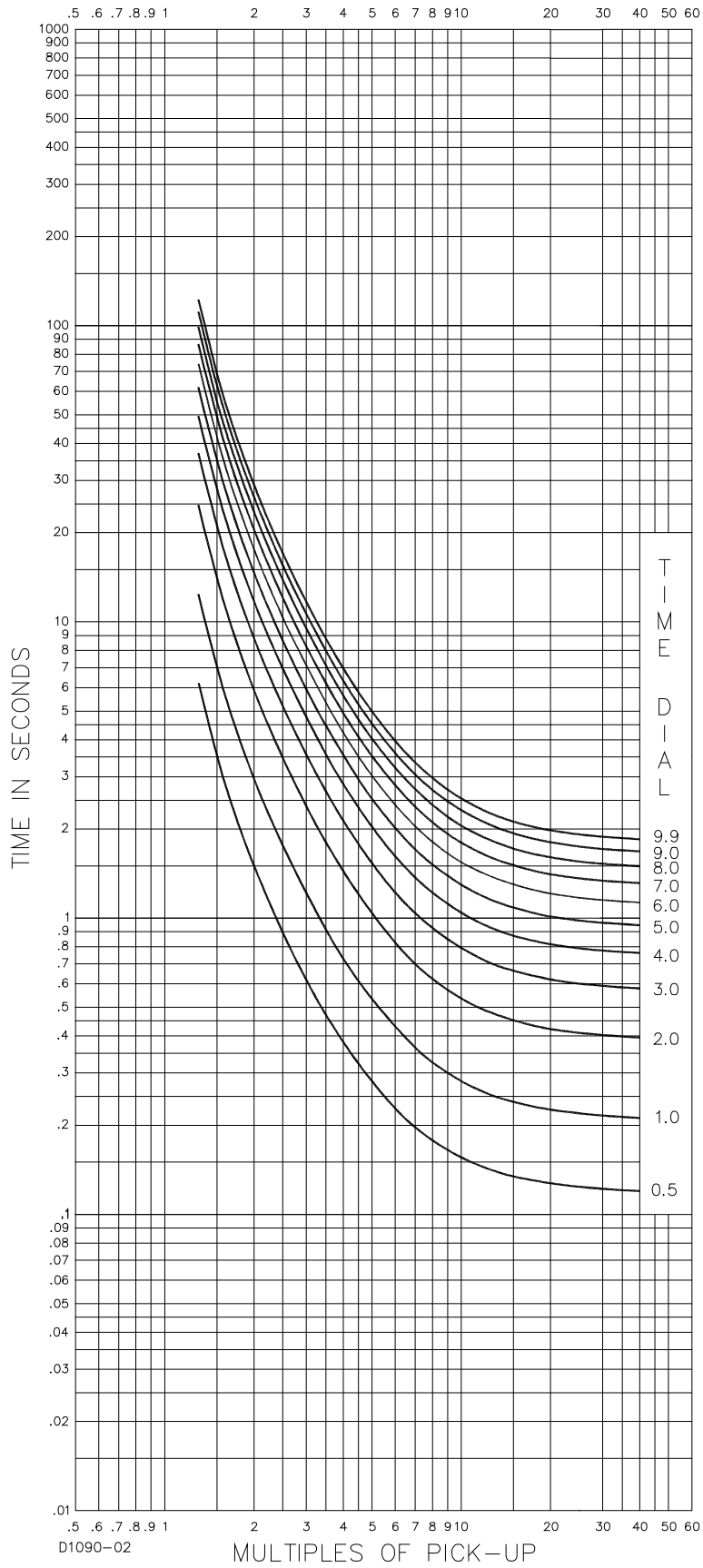

Figure 7-5. Time Characteristic Curve, I-Inverse (SW3-3 OFF, Similar to ABB CO-8)

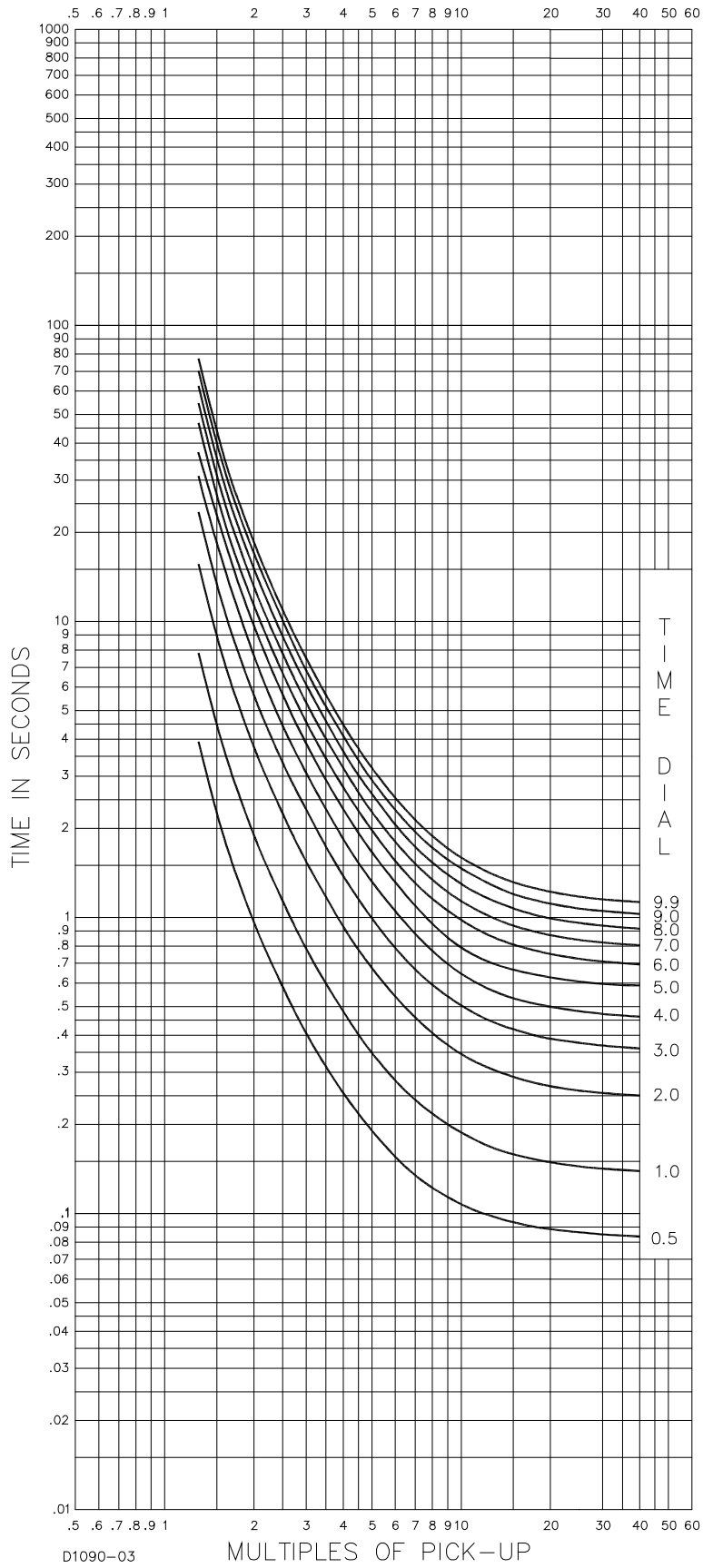

Figure 7-6. Time Characteristic Curve, V-Very Inverse (SW3-3 OFF, Similar to ABB CO-9)

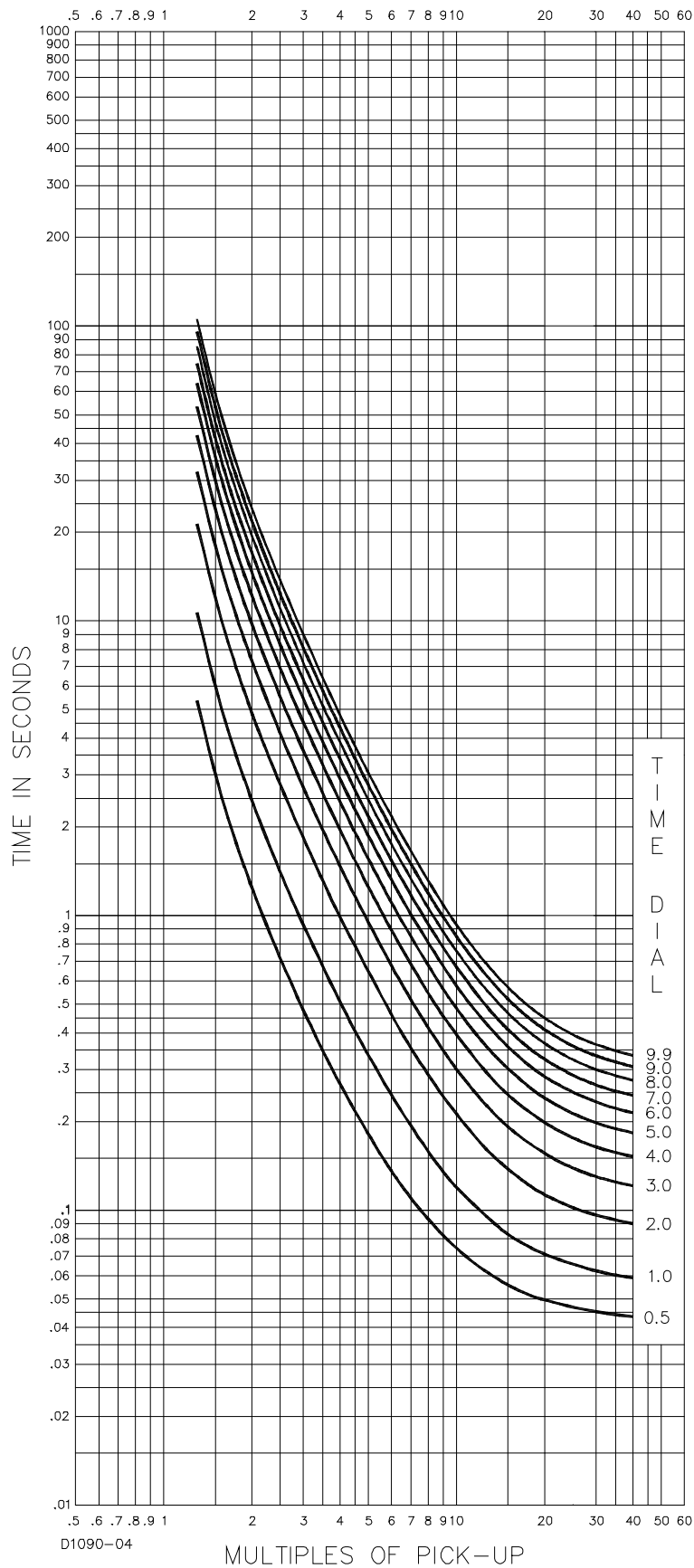

Figure 7-7. Time Characteristic Curve, E-Extremely Inverse (SW3-3 OFF, Similar to ABB CO-11)

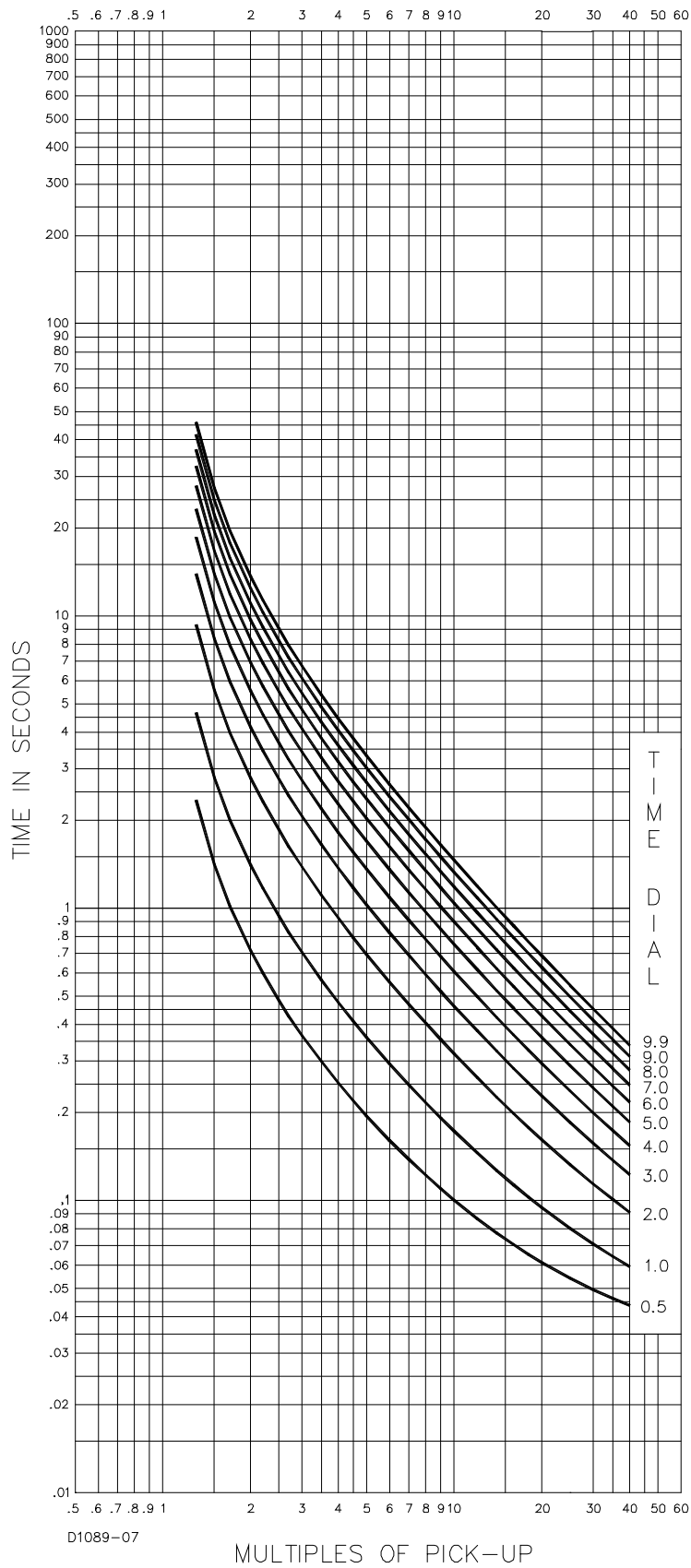

Figure 7-8. Time Characteristic Curve, BS142-B (BS142 Very Inverse)

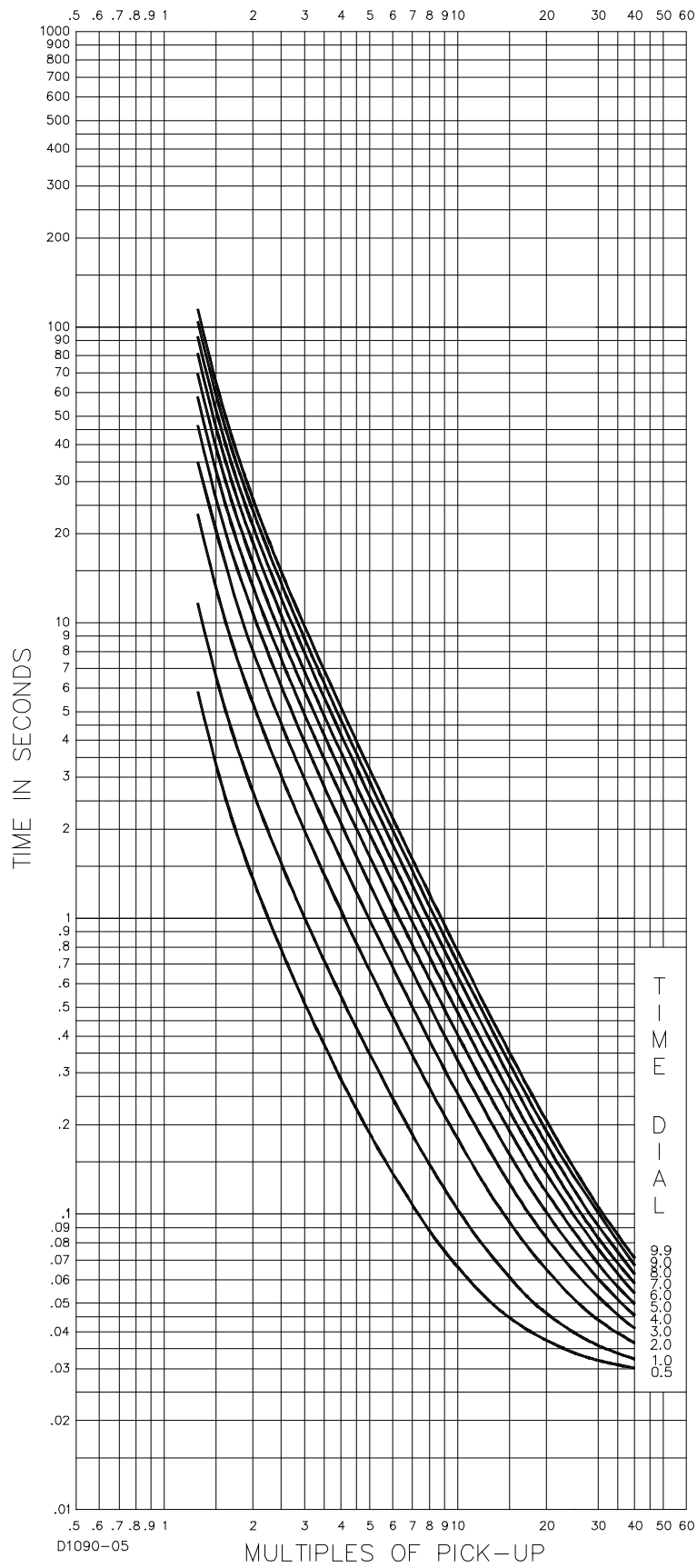

Figure 7-9. Time Characteristic Curve, BS142-C (BS142 Extremely Inverse)

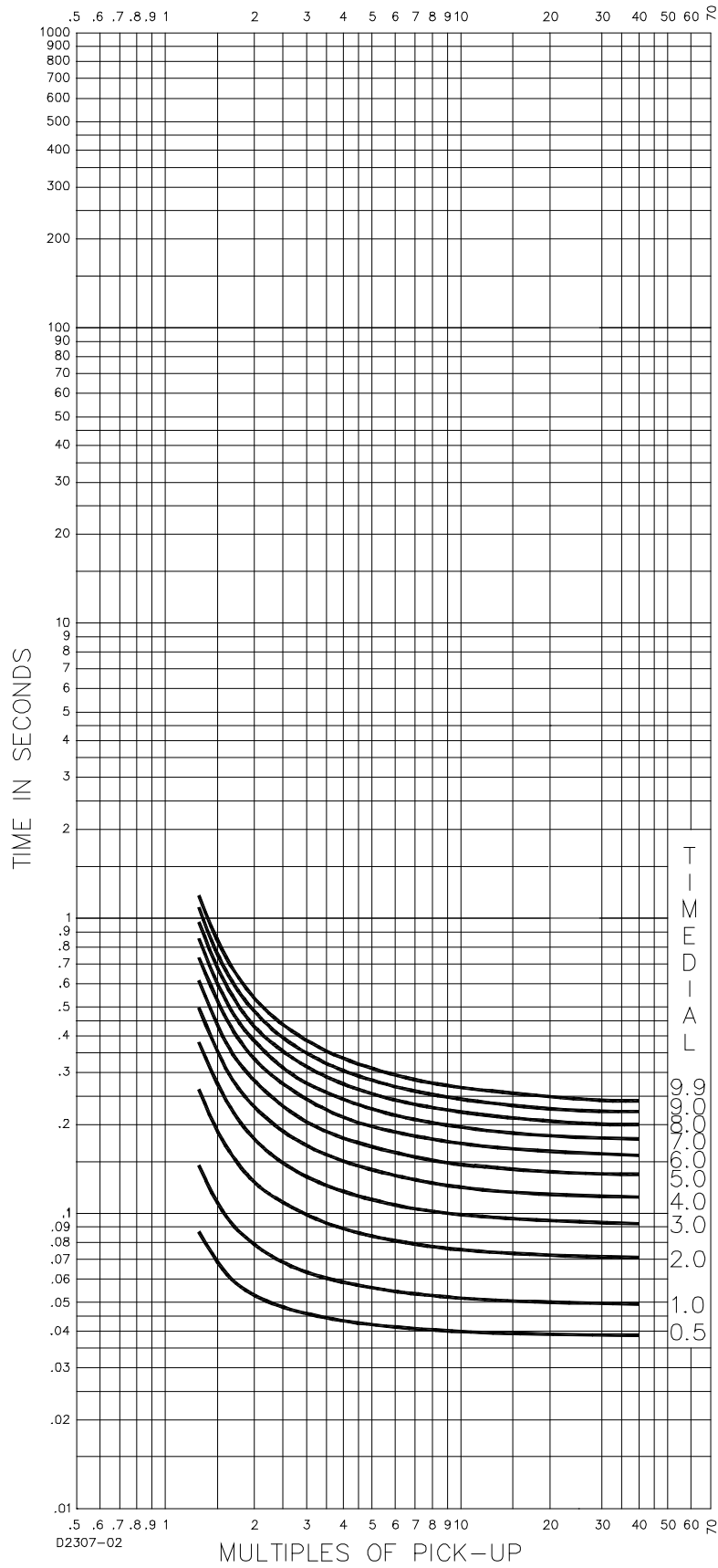

Figure 7-10. Time Characteristic Curve, S2-Short Inverse (SW3-3 ON, Similar to GE IAC 55)

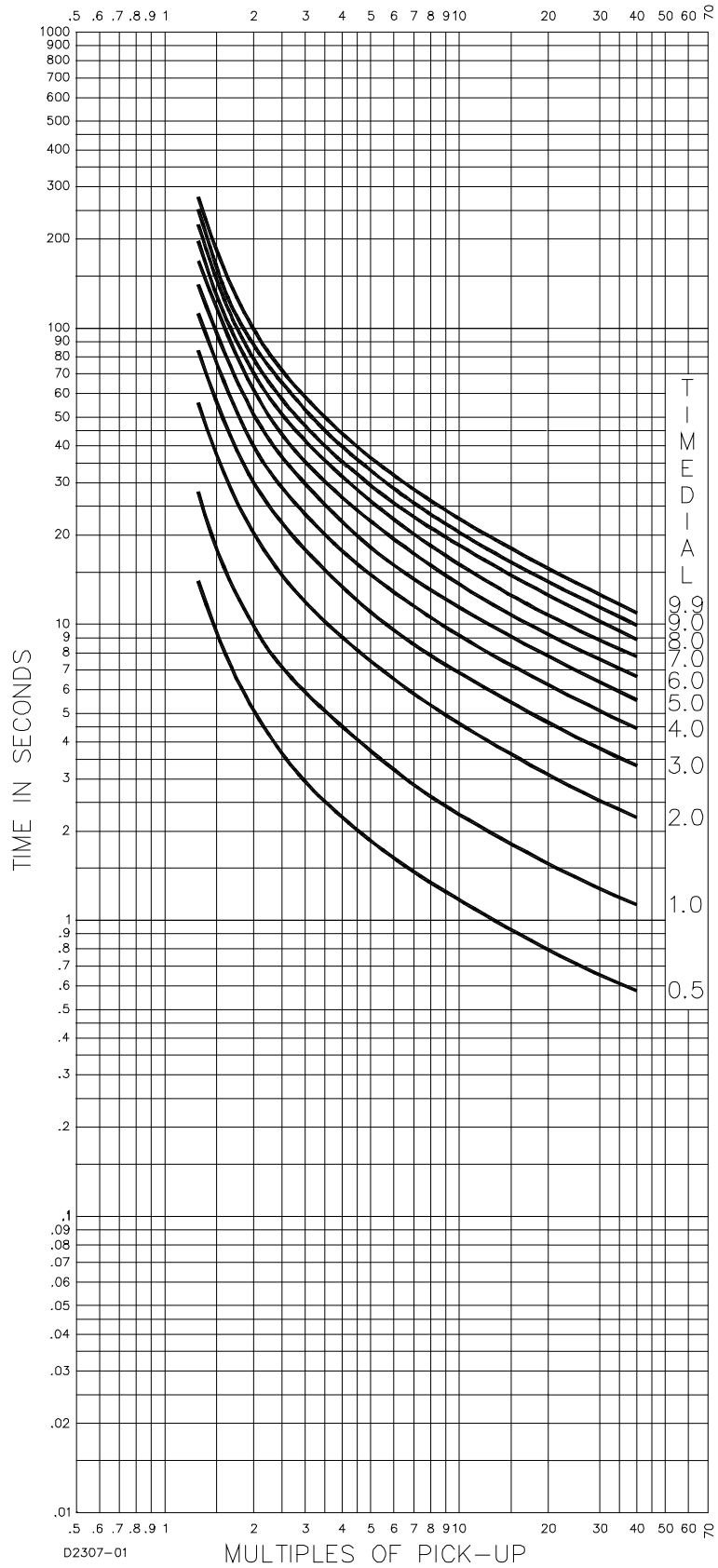

Figure 7-11. Time Characteristic Curve, L2-Long Inverse (SW3-3 ON, Similar to GE IAC 66)

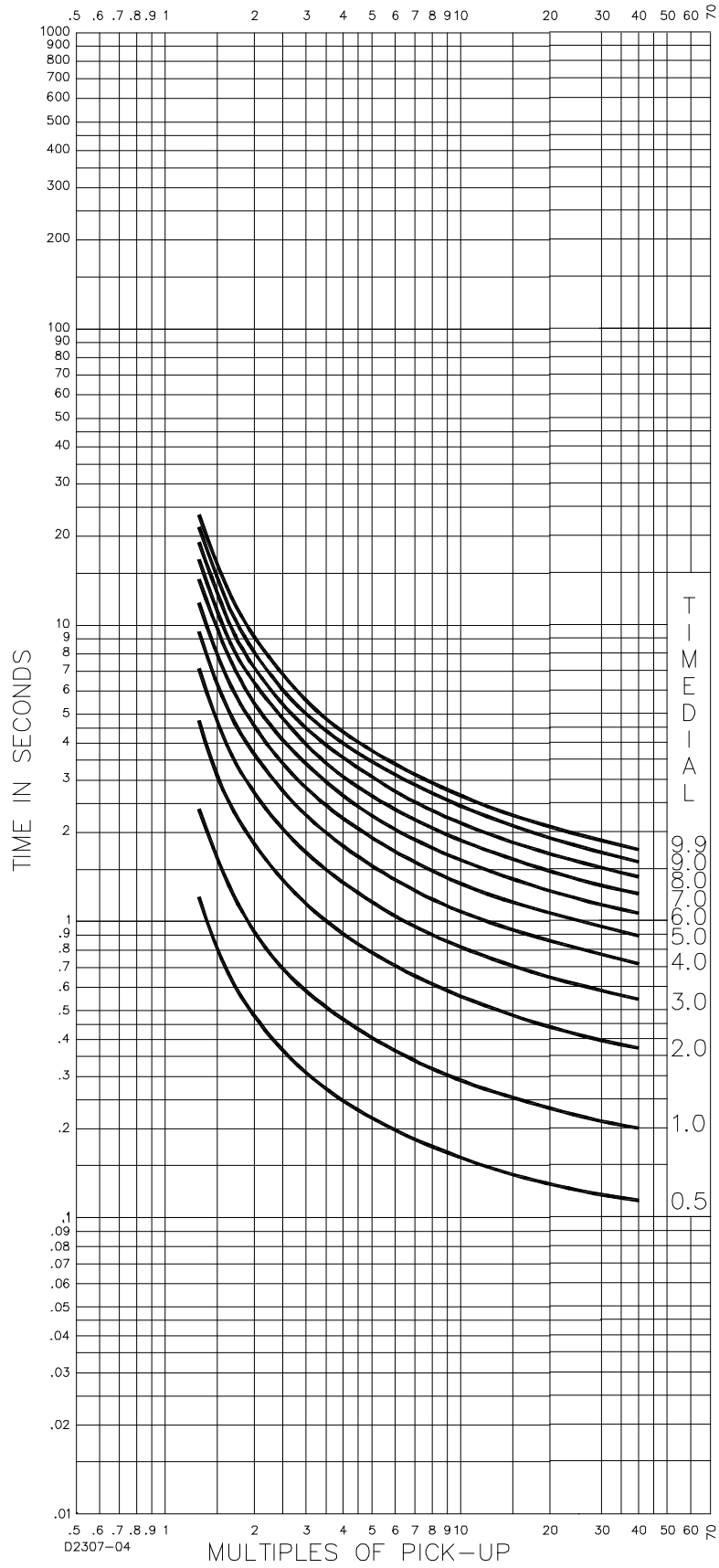

Figure 7-12. Time Characteristic Curve, I2-Inverse (SW3-3 ON, Similar to GE IAC 51)

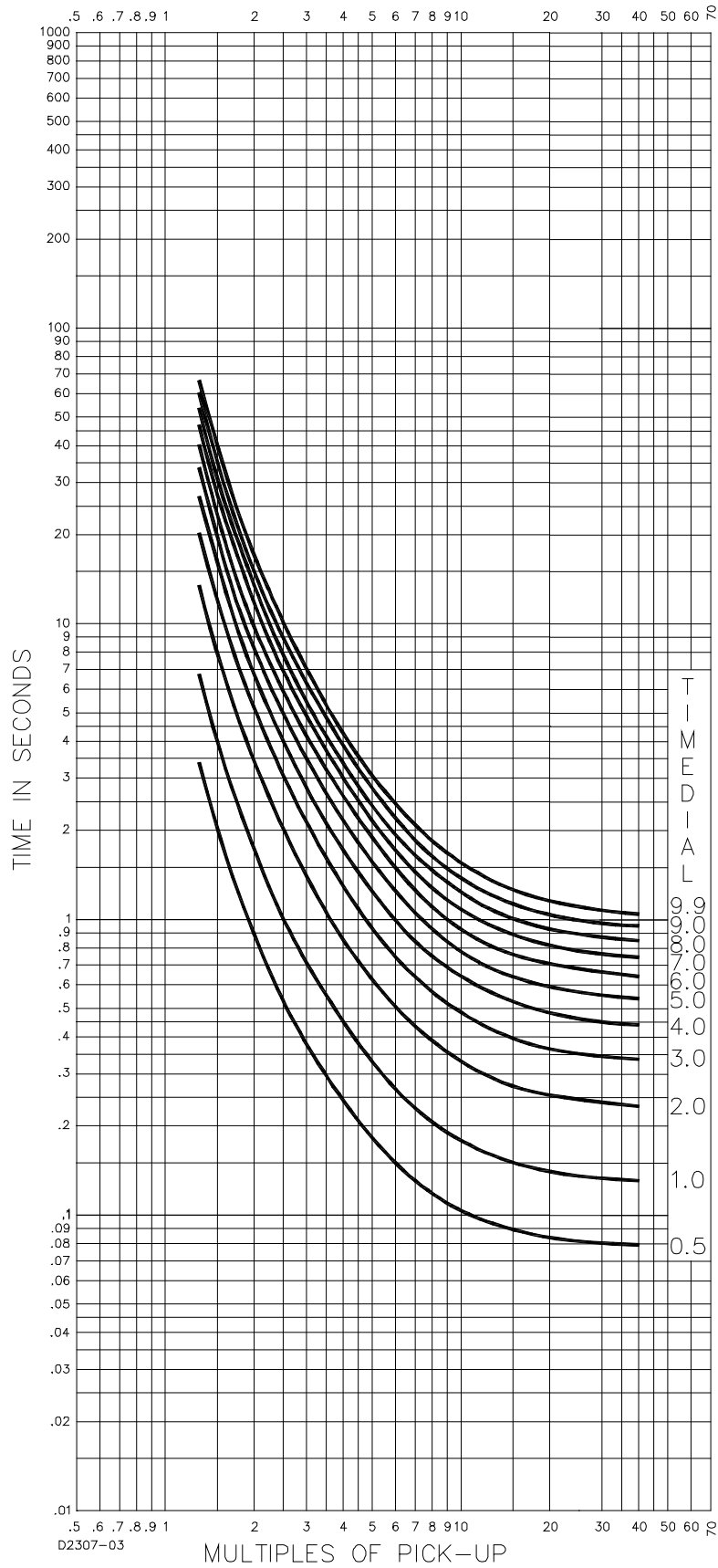

Figure 7-13. Time Characteristic Curve, V2-Very Inverse (SW3-3 ON, Similar to GE IAC 53)

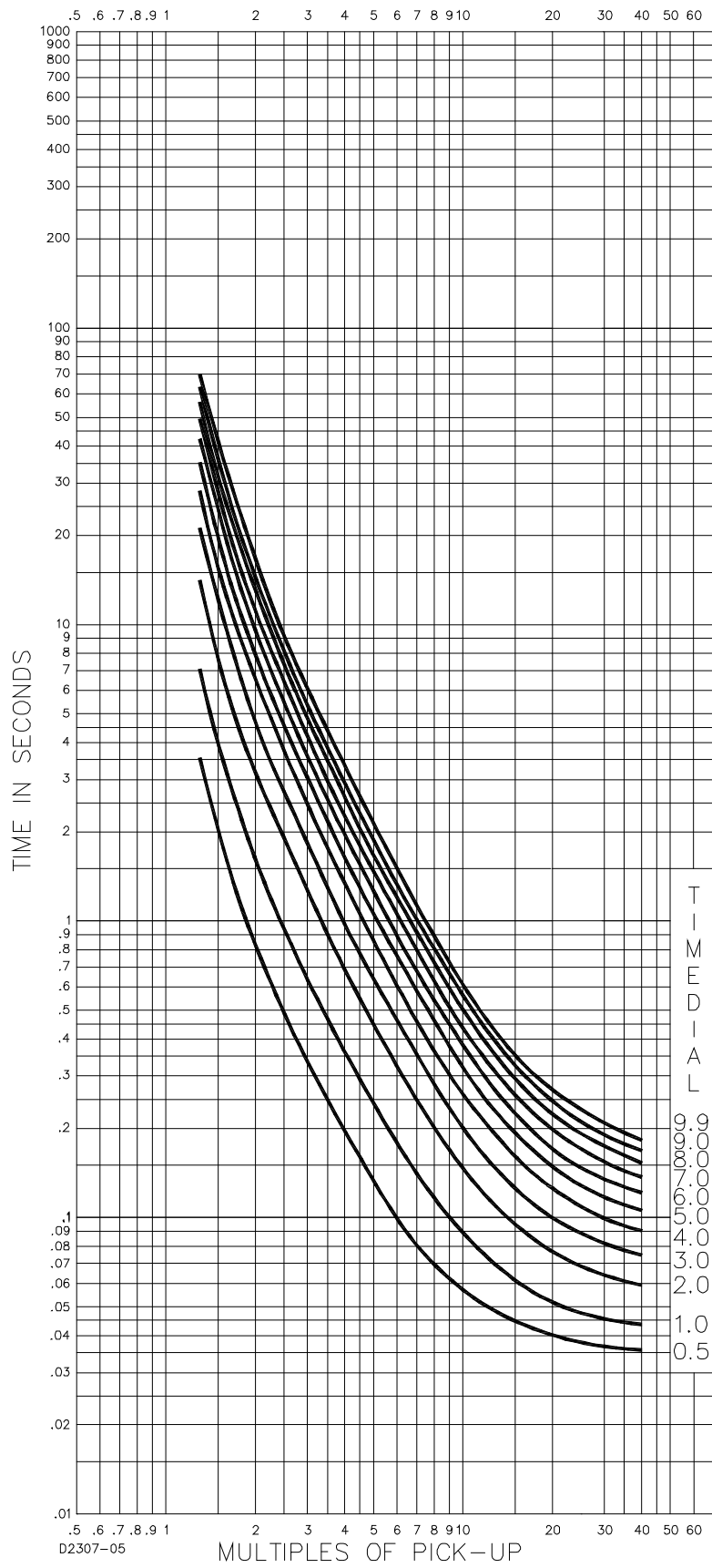

Figure 7-14. Time Characteristic Curve, E2-Extremely Inverse (SW3-3 ON, Similar to GE IAC 77)



Highland, Illinois USA
Tel: +1 618.654.2341
Fax: +1 618.654.2351
email: info@basler.com

Suzhou, P.R. China
Tel: +86 512.8227.2888
Fax: +86 512.8227.2887
email: chinainfo@basler.com