

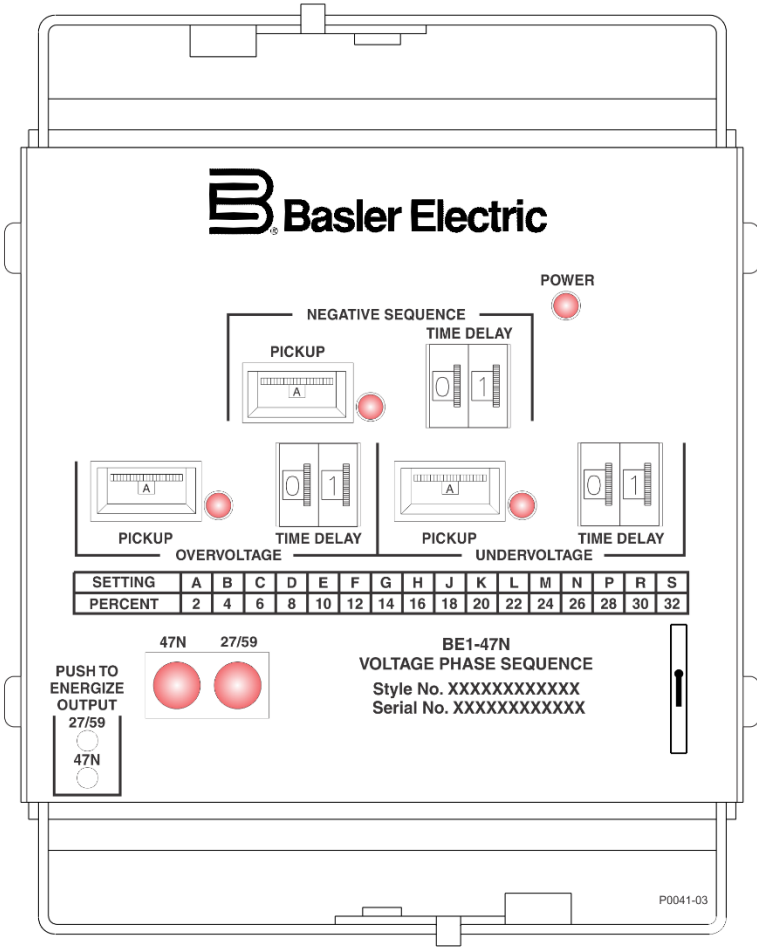



# BE1-47N

## Voltage Phase Sequence Relay

Instruction Manual



 **WARNING:** California's Proposition 65 requires special warnings for products that may contain chemicals known to the state of California to cause cancer, birth defects or other reproductive harm. Please note that by posting this Proposition 65 warning, we are notifying you that one or more of the Proposition 65 listed chemicals may be present in products we sell to you. For more information about the specific chemicals found in this product, please visit <https://www.basler.com/Prop65>.

# Preface

This instruction manual provides information about the installation and operation of the BE1-47N. To accomplish this, the following information is provided:

- General information and specifications
- Controls and indicators
- Functional description
- Installation
- Testing

## ***Conventions Used in this Manual***

---

Important safety and procedural information is emphasized and presented in this manual through warning, caution, and note boxes. Each type is illustrated and defined as follows.

### **Warning!**

Warning boxes call attention to conditions or actions that may cause personal injury or death.

### **Caution**

Caution boxes call attention to operating conditions that may lead to equipment or property damage.

### **Note**

Note boxes emphasize important information pertaining to installation or operation.



12570 State Route 143  
Highland IL 62249-1074 USA

[www.basler.com](http://www.basler.com)

[info@basler.com](mailto:info@basler.com)

Tel: +1 618.654.2341

Fax: +1 618.654.2351

© 2022 by Basler Electric

All rights reserved

First printing: September 1985

### Warning!

READ THIS MANUAL. Read this manual before installing, operating, or maintaining this equipment. Note all warnings, cautions, and notes in this manual as well as on the product. Keep this manual with the product for reference. Only qualified personnel should install, operate, or service this system. Failure to follow warning and cautionary labels may result in personal injury or property damage. Exercise caution at all times.

Basler Electric does not assume any responsibility to compliance or noncompliance with national code, local code, or any other applicable code. This manual serves as reference material that must be well understood prior to installation, operation, or maintenance.

For terms of service relating to this product and software, see the *Commercial Terms of Products and Services* document available at [www.basler.com/terms](http://www.basler.com/terms).

This publication contains confidential information of Basler Electric Company, an Illinois corporation. It is loaned for confidential use, subject to return on request, and with the mutual understanding that it will not be used in any manner detrimental to the interests of Basler Electric Company and used strictly for the purpose intended.

It is not the intention of this manual to cover all details and variations in equipment, nor does this manual provide data for every possible contingency regarding installation or operation. The availability and design of all features and options are subject to modification without notice. Over time, improvements and revisions may be made to this publication. Before performing any of the following procedures, contact Basler Electric for the latest revision of this manual.

The English-language version of this manual serves as the only approved manual version.

# Revision History

A historical summary of the changes made to this instruction manual is provided below. Revisions are listed in reverse chronological order.

## Instruction Manual Revision History

Manual Revision and Date	Change
P, May 2022	<ul style="list-style-type: none"> <li>Added a note about EMI suppression in the <i>Installation</i> chapter</li> </ul>
O	<ul style="list-style-type: none"> <li>This revision letter not used</li> </ul>
N, Dec 2021	<ul style="list-style-type: none"> <li>Adjusted style chart to reflect obsolescence of current-operated targets</li> </ul>
M, Oct 2020	<ul style="list-style-type: none"> <li>Changed undervoltage dropout from 98% of pickup to 102% of pickup</li> </ul>
L2, Apr 2019	<ul style="list-style-type: none"> <li>Adjusted wording of California Proposition 65 warning statement</li> </ul>
L1, Nov 2018	<ul style="list-style-type: none"> <li>Added California Proposition 65 warning statement</li> </ul>
L, Jan 2018	<ul style="list-style-type: none"> <li>In Table 1, locator F added note about power supply status output</li> <li>Updated pickup and accuracy specifications for negative sequence voltage</li> </ul>
K, Mar 2016	<ul style="list-style-type: none"> <li>Minor improvements to installation drawings</li> <li>Removed GOST-R certification</li> <li>Minor edits throughout manual</li> </ul>
J, Mar 2012	<ul style="list-style-type: none"> <li>Updated GOST-R certification statement</li> <li>Standardized case and cover drawings</li> <li>Updated storage recommendation statement</li> </ul>
I	<ul style="list-style-type: none"> <li>This revision letter not used</li> </ul>
H, Sep 2007	<ul style="list-style-type: none"> <li>Added manual part number and revision letter to all page footers</li> <li>Updated power supply burden data</li> <li>Updated target indicator description</li> </ul>
G, Jul 2006	<ul style="list-style-type: none"> <li>Moved content of <i>Manual Change Information</i> chapter to the manual preface</li> <li>Moved content of the <i>Maintenance</i> chapter to the <i>Installation</i> chapter</li> <li>Corrected target options shown in style chart (added option N [None])</li> <li>Corrected/clarified output contact specifications</li> <li>Added GOST-R certification statement</li> <li>Updated all front panel illustrations to show laser-cut overlay</li> </ul>
F, Feb 2001	<ul style="list-style-type: none"> <li>Updated the S1 case drawings</li> <li>Updated the style chart</li> </ul>
E, D, C, B, A, —	<ul style="list-style-type: none"> <li>Information for these manual versions not available</li> </ul>



# Contents

Introduction .....	1-1
Controls and Indicators .....	2-1
Functional Description.....	3-1
Installation.....	4-1
Testing .....	5-1
Specifications.....	6-1



# 1 • Introduction

BE1-47N Voltage Phase Sequence Relays respond to negative sequence voltage ( $V_2$ ) which results from a fault or misconnection on a balanced, three-phase system.

## ***Application***

---

BE1-47N relays are designed to protect equipment from damage caused by phase failure, reverse phase sequence, phase unbalance, undervoltage, or overvoltage.

The relay detects reverse phase connection of lines, transformers, motors, generators, and synchronous condensers and is often applied in automatic transfer schemes to assure connection of proper phase rotation as well as voltage conditions. When used in a motor application, the relay provides protection by preventing motor startup during open-phase or reverse-phase conditions and by tripping the motor off line for phase unbalance, undervoltage, or overvoltage conditions.

Negative sequence voltage is the result of any unequal phase condition on the source. This can be due to unequal single-phase loads on the system or unequal transformer impedances between phases. A 1 to 2% level can normally be expected in an industrial supply. Any significant increase above this level can indicate a power service problem and could lead to serious plant problems. The BE1-47N has the ability to detect negative sequence voltage levels of this magnitude.

Undervoltage and voltage balance relays have traditionally been applied to protect induction motors from operating with one phase open. These relays may not reliably detect this condition due to the back-EMF of the motor on the open phase. However, an induction motor with a starting current of 6 per unit generates a negative sequence voltage of 16% if fully loaded when a fuse opens. The negative sequence voltage will be somewhat reduced if the motor is not fully loaded. The sensitivity of the BE1-47N and its insensitivity to frequency allow reliable protection to be applied to motors.

Motor losses and current unbalance increase with the negative-sequence voltage level. The increased loss due to negative sequence voltage is not a function of motor load but is independent. A machine operating with 3.5% negative sequence voltage will have its losses increased by 25%. An open fuse on a power factor correction capacitor bank can result in a significant increase in negative sequence voltage. The effect of this condition can be costly.

BE1-47N relays can be applied to protect motor buses from an open phase. It can also be applied to protect critical individual motors, static, and non-rotating loads from the effects of negative sequence voltage.

A choice of time delay characteristics allows the relay to respond in the desired manner for a wide variety of transient and fault conditions.

BE1-47N relays may also be used to provide overvoltage and undervoltage protection. A separate time delay is utilized to prevent shutdown of equipment during minor voltage dips and to permit sequential operation when the relay is being used in a supervisory capacity.

## **Phase Rotation Sensitivity**

Relays that use phase-to-phase voltage to determine negative sequence are sensitive to phase rotation. BE1-47N relays are phase rotation sensitive. Unless otherwise noted, all connections shown in this manual assume ABC rotation.

## ***Model and Style Number***

---

BE1-47N electrical characteristics and operational features are defined by a combination of letters and numbers that make up the style number. Model number BE1-47N designates the relay as a Basler Electric Voltage Phase Sequence Relay. The model number, together with the style number, describes the options included in a specific device and appears on the front panel, draw-out cradle, and inside the case assembly.

The style number identification chart for the BE1-47N relay is illustrated in Figure 1-1.

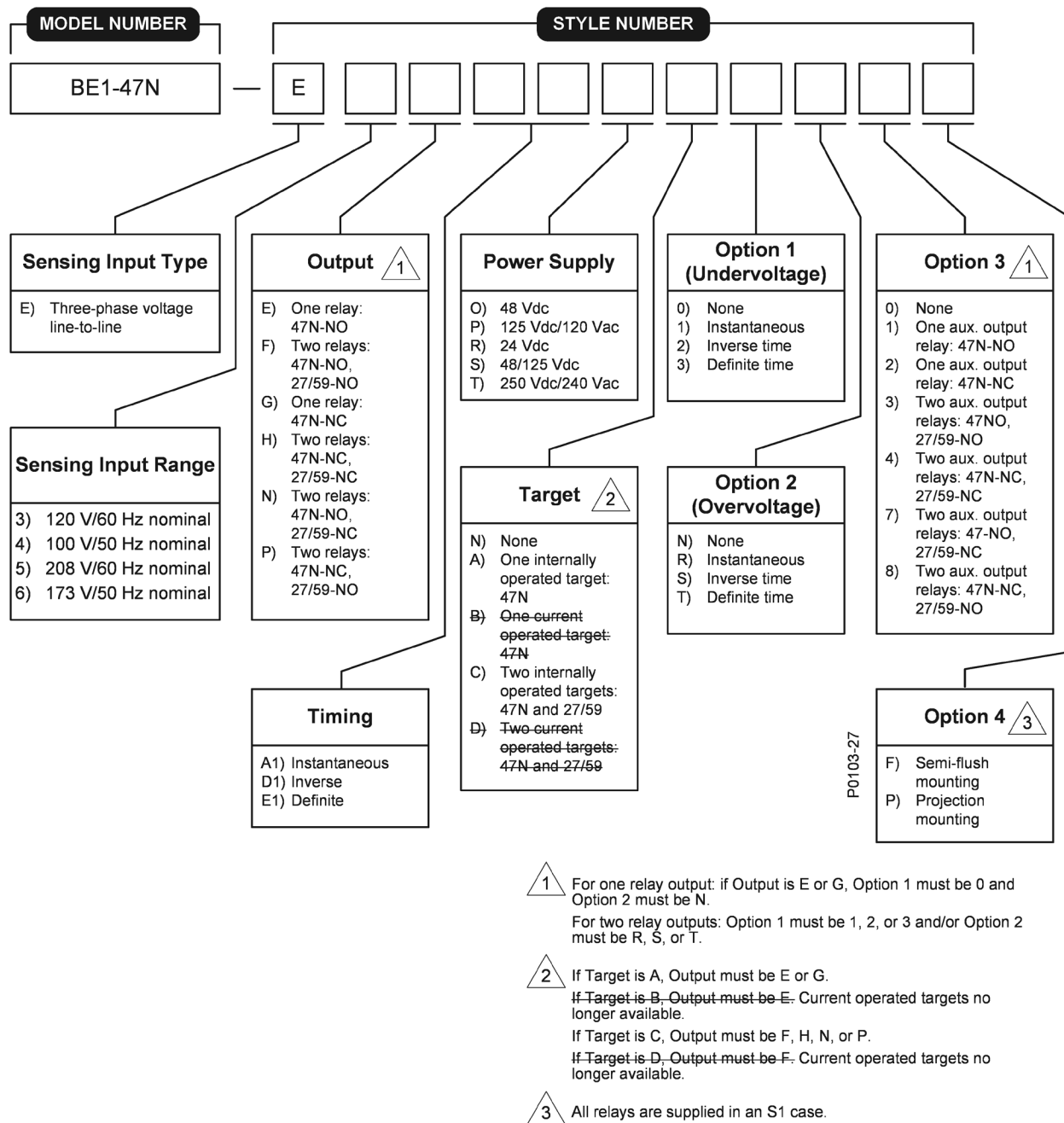

Figure 1-1. BE1-47N Style Identification Chart

### Style Number Example

If a BE1-47N relay has a style number of **E3FE1PA1R0F**, the relay has the following features:

- E** Three-phase, line-to-line voltage sensing
- 3** 120 Vac, 60 Hz nominal sensing voltage input
- F** Two output relays with normally open (NO) contacts
- E1** Timing characteristic uses definite time delays
- P** Relay control power is 125 Vdc or 120 Vac, nominal

- A** One internally operated target indicator
- 1** Instantaneous undervoltage element
- R** Instantaneous overvoltage element
- 0** No auxiliary output relay
- F** Semi-flush mounting case



## 2 • Controls and Indicators

All BE1-47N controls and indicators are located on the front panel. The controls and indicators are shown in Figure 2-1 and described in Table 2-1. Figure 2-1 illustrates a relay with the maximum number of controls and indicators. Your relay may not have all of the controls and indicators shown and described here.

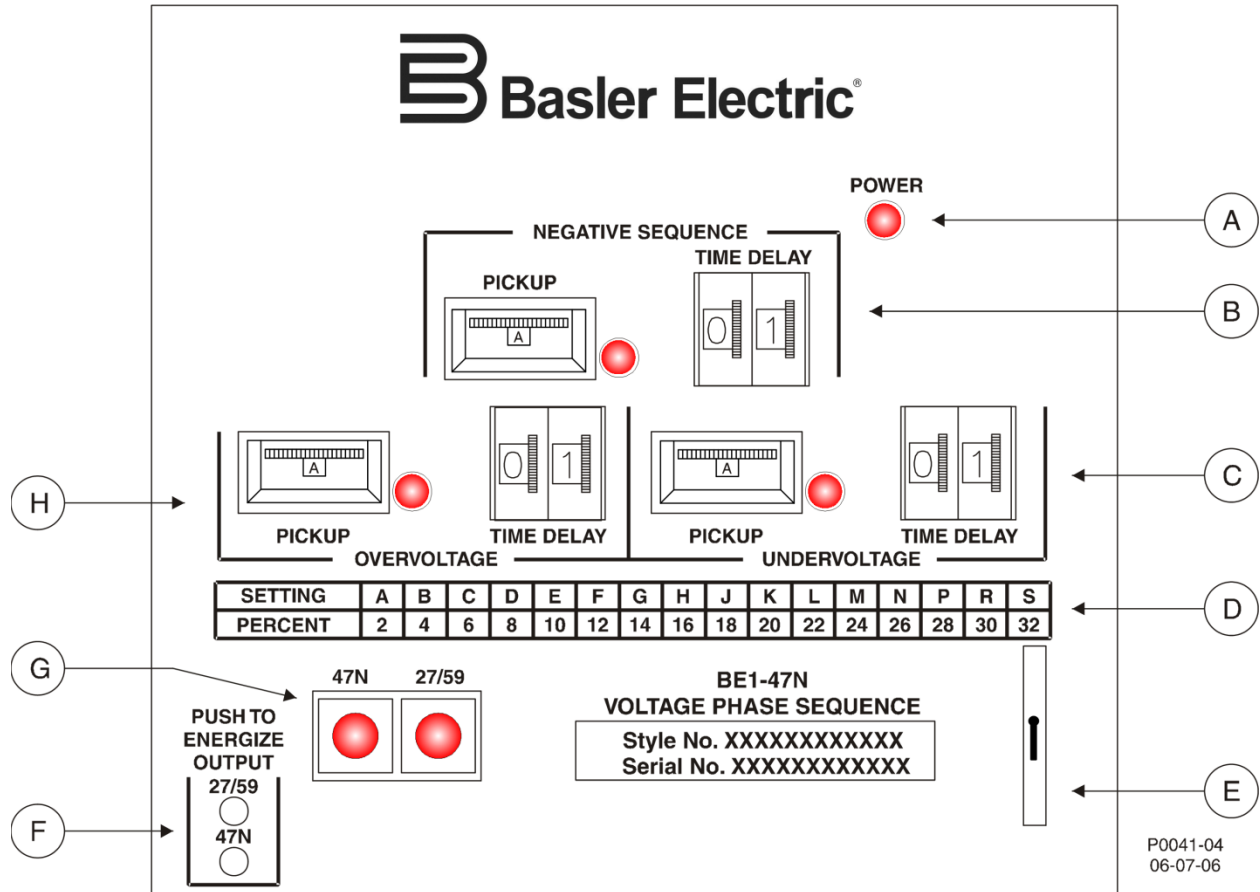

Figure 2-1. BE1-47N Controls and Indicators

Table 2-1. Control and Indicator Descriptions

Locator	Description
A	<b>Power Indicator.</b> This red LED lights when operating power is applied to the relay.
B	<b>Negative Sequence Voltage Controls and Indicator.</b> These elements consist of a pickup thumbwheel switch, a time delay thumbwheel switch, and a pickup indicator. The 16-position pickup switch adjusts the negative sequence voltage pickup setpoint. Switch positions A through S correspond to setpoints ranging from 2 to 32% of the nominal voltage, in 2% increments. The front panel setting chart (locator D) lists the setpoint for each switch position. Relays with definite or inverse timing have a time delay switch that sets the duration of timing for negative sequence voltage protection. Instantaneous timing is not user-adjustable, so relays with instantaneous timing do not have a time delay switch. The red pickup LED lights when the level of negative sequence voltage exceeds the setting of the negative sequence voltage pickup switch.

Locator	Description
C	<p><i>Undervoltage Controls and Indicator.</i> These elements consist of a pickup thumbwheel switch, a time delay thumbwheel switch, and a pickup indicator. Undervoltage elements are present only if option 1 of the relay style number is 1, 2, or 3.</p> <p>The 16-position pickup switch adjusts the undervoltage pickup setpoint. Switch positions A through S correspond to setpoints ranging from 2 to 32% below the nominal (single-phase) voltage, in 2% increments. The front panel setting chart (locator D) lists the setpoint for each switch position.</p> <p>Relays with definite or inverse timing have a time delay switch that sets the duration of timing for undervoltage protection. Instantaneous timing is not user-adjustable, so relays with instantaneous timing do not have an undervoltage time delay switch.</p> <p>The red pickup LED lights when the level of (single-phase) voltage decreases below the setting of the undervoltage pickup switch.</p>
D	<p><i>Setting Chart.</i> To aid in setting pickup levels, this chart lists the percent difference (from nominal) setting for each lettered position of the negative sequence voltage, overvoltage, and undervoltage pickup setting switches.</p>
E	<p><i>Target Reset Switch.</i> This switch is operated to reset the target indicators.</p>
F	<p><i>Output Test Pushbuttons.</i> These pushbuttons allow manual actuation of the output relays. Output relay actuation is achieved by inserting a nonconductive rod through the front panel access holes. Note: the power supply status output contact is not affected.</p>
G	<p><i>Target Indicators.</i> The electronically latched red target indicators illuminate when the corresponding output relay energizes. To ensure proper operation of current-operated targets, the current flowing through the trip circuit must be 200 mA or higher. Target indicators are reset by operating the target reset switch (locator E).</p>
H	<p><i>Overvoltage Controls and Indicator.</i> These elements consist of a pickup thumbwheel switch, a time delay thumbwheel switch, and a pickup indicator. Overvoltage elements are present only if option 2 of the relay style number is R, S, or T.</p> <p>The 16-position pickup switch adjusts the overvoltage pickup setpoint. Switch positions A through S correspond to setpoints ranging from 2 to 32% above the nominal (single-phase) voltage, in 2% increments. The front panel setting chart (locator D) lists the setpoint for each switch position.</p> <p>Relays with definite or inverse timing have a time delay switch that sets the duration of timing for overvoltage protection. Instantaneous timing is not user-adjustable, so relays with instantaneous timing do not have an overvoltage time delay switch.</p> <p>The red pickup LED lights when the level of (single-phase) voltage increases above the setting of the overvoltage pickup switch.</p>

## 3 • Functional Description

BE1-47N relay functions are illustrated in Figure 3-1 and described in the following paragraphs.

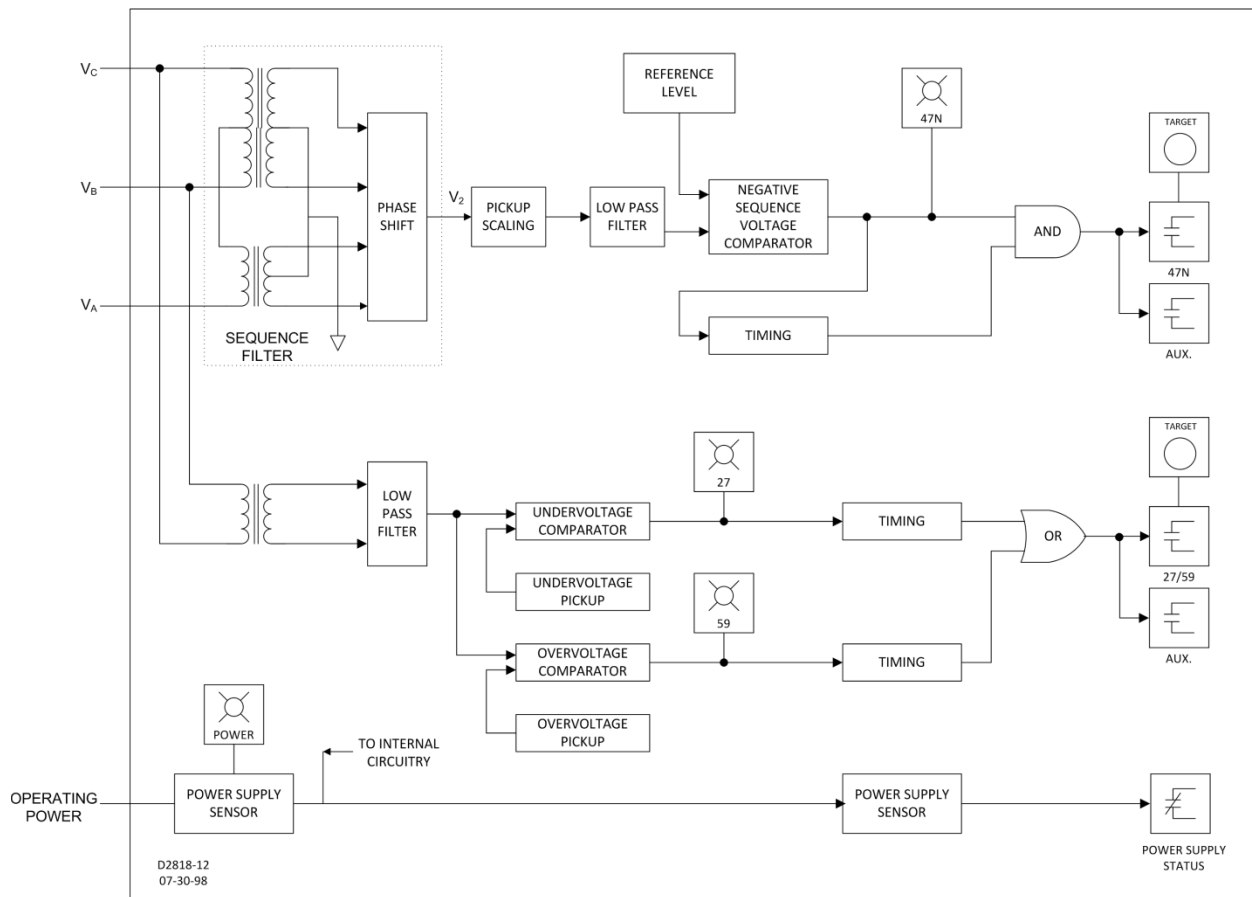

Figure 3-1. Function Block Diagram

### Voltage Sensing

One of two nominal voltage levels may be specified for a system frequency of 50 hertz or 60 hertz. Voltage sensing input options are summarized in Table 3-1.

Table 3-1. Voltage Sensing Input Options

Sensing Input Option	Nominal Voltage	Frequency
3	120 Vac	60 Hz
4	100 Vac	50 Hz
5	208 Vac	60 Hz
6	173 Vac	50 Hz

Three-phase system voltage is supplied to internal potential transformers (PTs). These PTs are an integral part of the sequence filter and provide isolation, step-down scaling, and phasor summation to eliminate the zero-sequence component of the sensed voltages.

### Phase Shifting

The respective secondary voltages are phase shifted  $\pm 45^\circ$  each, with respect to signal ground and then summed to nullify the positive sequence component.

## Pickup Scaling

The resolved negative sequence voltage ( $V_2$ ) ac signal is then applied to the pickup scaling network (switch S1 and its associated resistors). The pickup network establishes per-unit (PU) values of negative sequence voltage for the comparison and timing functions.

## Low-Pass Filter

The sensing circuits for negative sequence voltage, overvoltage, and undervoltage are designed to operate on the fundamental frequencies of 50 or 60 hertz. The low-pass filter passes the fundamental frequencies and attenuates the higher frequencies.

## Negative Sequence Voltage Comparator

The proportionate negative sequence ( $V_2$ ) signal is compared to a reference level. When the level of the per-unit negative sequence voltage exceeds the reference level, the pickup indicator lights and timing is initiated.

## Overvoltage/Undervoltage Comparator

Optional single-phase overvoltage and undervoltage circuits operate on the voltage magnitude. The single-phase ac signal is low-pass filtered and passed to the respective comparator where it is compared to the pickup settings for each circuit. If either pickup setting has been exceeded (overvoltage or undervoltage), the appropriate LED lights and timing is initiated.

## Timing

One of three timing characteristics is available for each of the three protection functions: definite, inverse, or instantaneous. The timing characteristic may be independently selected for each protection function. Table 3-2 identifies the timing style selections for negative sequence voltage, undervoltage, and overvoltage protection.

**Table 3-2. Timing Characteristic Style Number Selections**

Protection Function	Timing Characteristic		
	Instantaneous	Inverse	Definite
Undervoltage (27)	xxx-xxx-x1xxx	xxx-xxx-x2xxx	xxx-xxx-x3xxx
Negative Sequence Voltage (47N)	xxx-A1x-xxxxx	xxx-D1x-xxxxx	xxx-E1x-xxxxx
Overvoltage (59)	xxx-xxx-xxRxx	xxx-xxx-xxSxx	xxx-xxx-xxTxx

Definite timing is adjustable from 0.1 to 9.9 seconds in increments of 0.1 seconds.

The response time of instantaneous timing is less than 50 milliseconds. When the timing characteristic for a protection function is definite or inverse and the time delay setting is 00, instantaneous timing is achieved.

Inverse timing is adjustable from 01 to 99 in increments of 1 (see Figures 3-2 through 3-4 for the inverse time characteristic curves). When evaluating inverse curves for overvoltage or undervoltage protection, note that timing is based on the percent difference from the system's nominal voltage. For example, refer to Figure 3-4. If the monitored voltage is at a level of 18% below system nominal, the portion of the curves below 18% (e.g., 13%, 8%, etc.) has no effect on the timing characteristic. In other words, the timing curve beginning is dependent upon the monitored voltage percent difference from the system's nominal voltage. Inverse timing characteristics preceding this defined point are nonexistent.

MULTIPLES OF PICK-UP SETTING

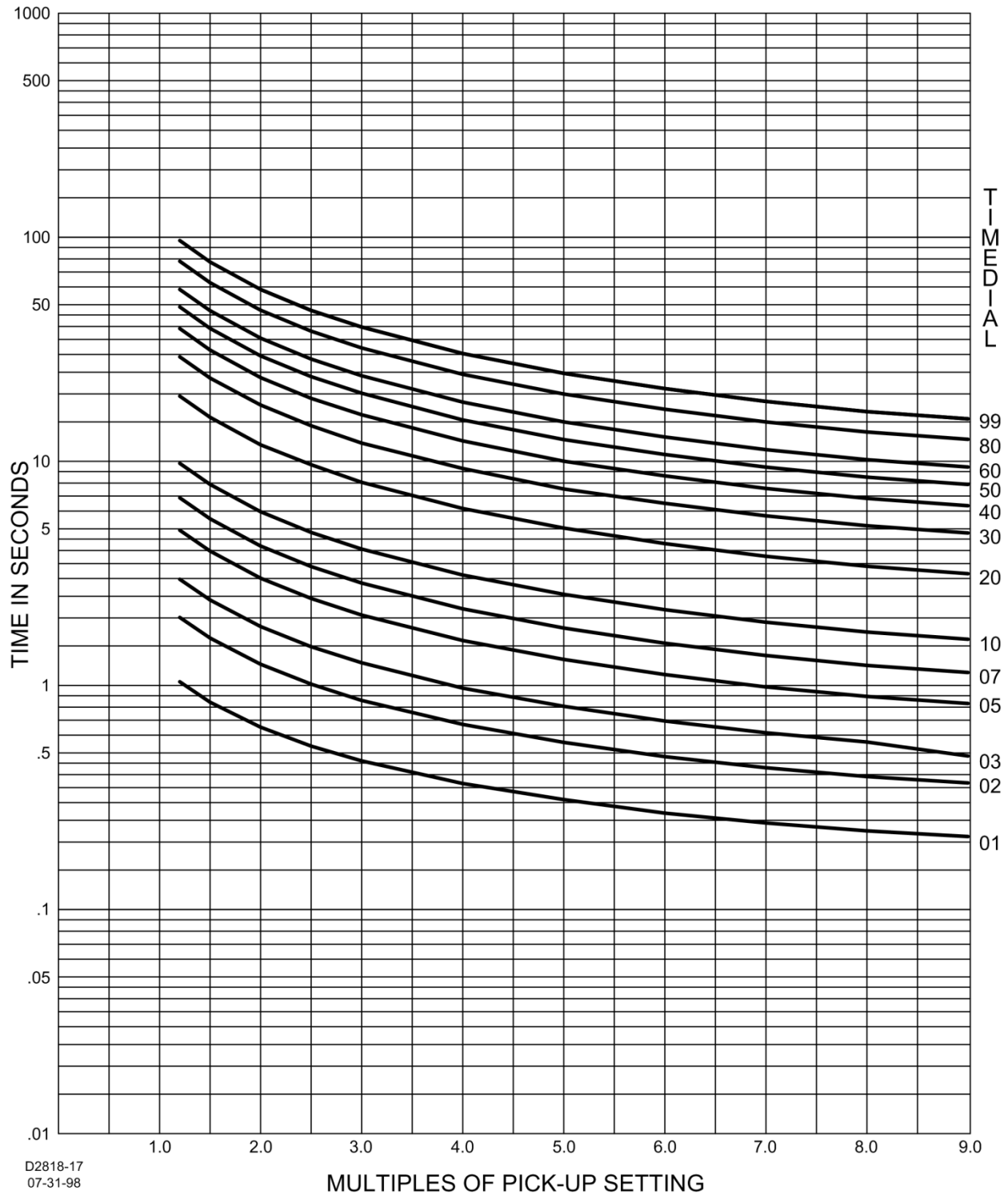

Figure 3-2. Negative Sequence Voltage Inverse Time Characteristic Curves

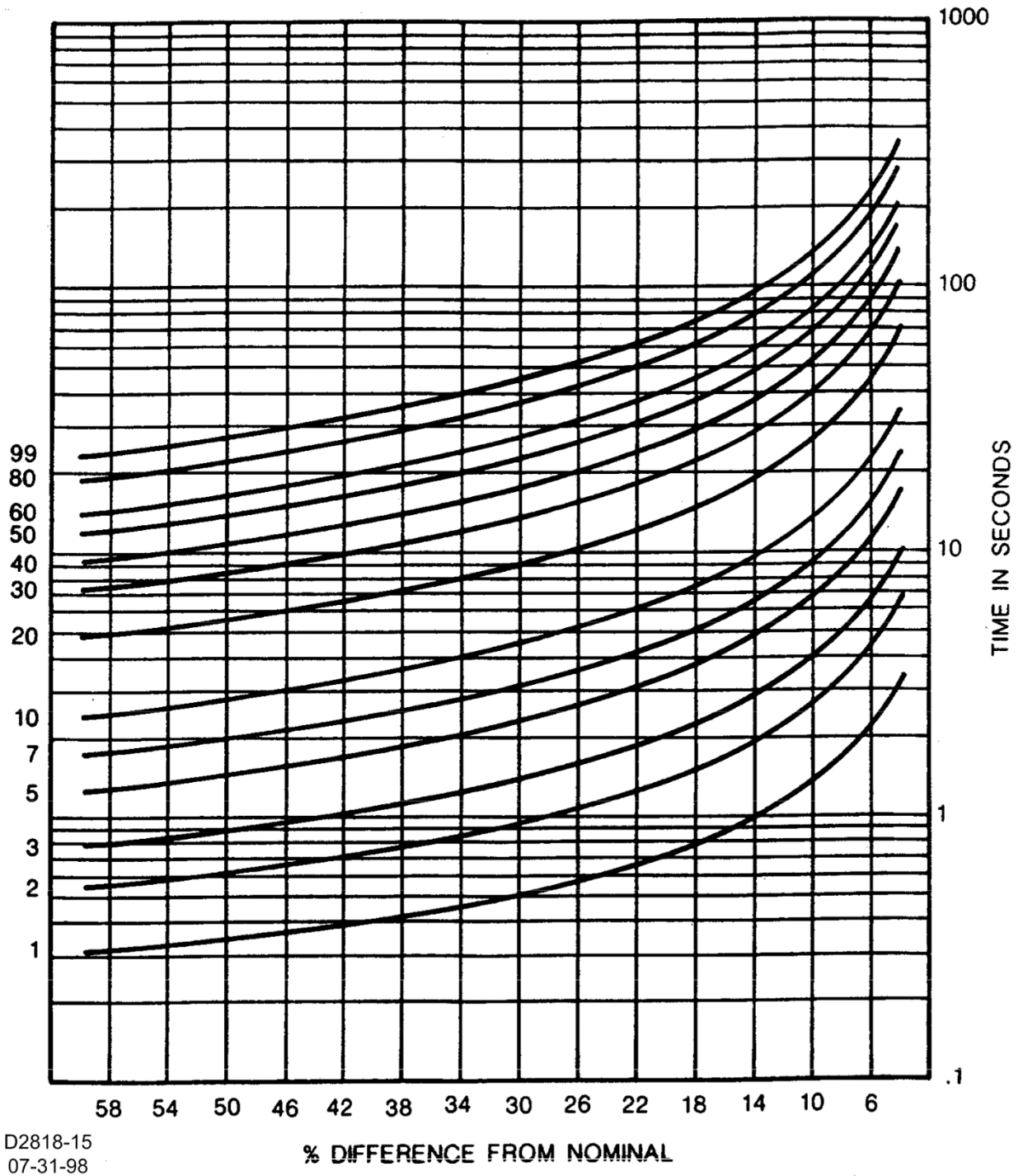

Figure 3-3. Undervoltage Inverse Time Characteristic Curves

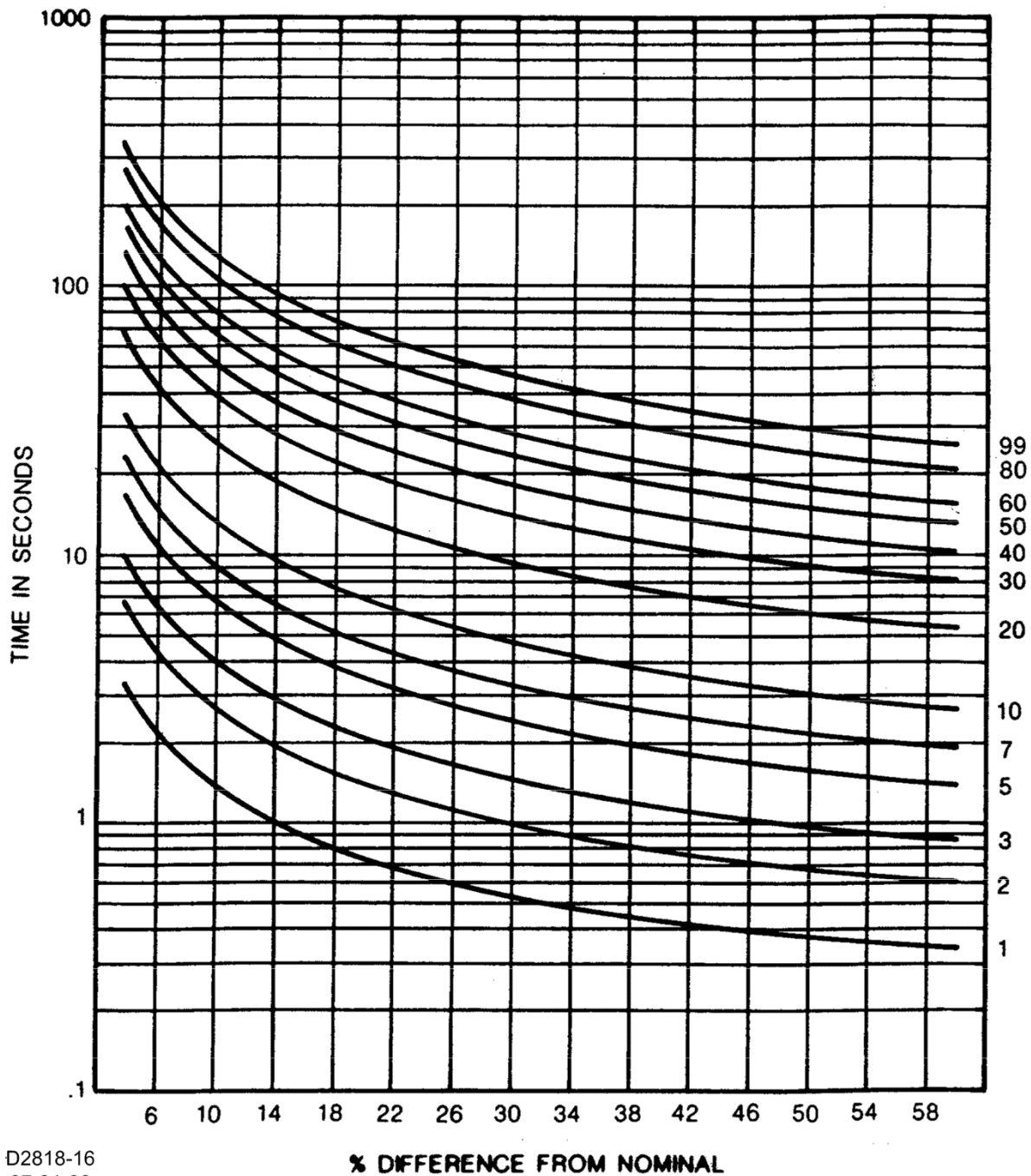

Figure 3-4. Overvoltage Inverse Time Characteristic Curves

## Outputs

BE1-47N outputs consist of the main, tripping output relays, auxiliary output relays, and a power supply status output relay.

### Main Outputs

Output relays, rated for tripping duty, are provided for each protection function. Normally open (NO) or normally closed (NC) relay contacts may be specified for each protection function. Table 3-3 lists the possible output relay configurations.

**Table 3-3. Main Output Contact Configurations**

Output Option	Protection Function	Output Configuration	
		NO	NC
E	47N	•	
F	47N	•	
	27/59	•	
G	47N		•
H	47N		•
	27/59		•
N	47N	•	
	27/59		•
P	47N		•
	27/59	•	

### Auxiliary Outputs

Auxiliary output relays that operate at the same time as the main output relays are also available (style chart option 3). Table 3-4 lists the possible auxiliary output relay configurations.

**Table 3-4. Auxiliary Output Contact Configurations**

Style Chart Option 3	Protection Function	Output Configuration	
		NO	NC
0	N/A		
1	47N	•	
2	47N		•
3	47N	•	
	27/59	•	
4	47N		•
	27/59		•
7	47N	•	
	27/59		•
8	47N	•	
	27/59		•

### Power Supply Status Output

The power supply status relay has a set of normally closed contacts and energizes when operating power is applied to the BE1-47N. If relay operating power is lost or either side of the power supply output (+12 Vdc or -12 Vdc) fails, the power supply status relay de-energizes and closes the power supply status output contacts.

### Indicators

LEDs indicate power supply status and protection function pickup.

The power LED lights when operating power is applied to the relay and the relay power supply is operating normally.

One LED is provided for each protection function. An LED lights when the function's setpoint is exceeded and the protection function is timing toward a trip.

## ***Power Supply***

---

Operating power for the relay circuitry is supplied by a wide range, electrically isolated, low-burden power supply. Power supply operating power is not polarity sensitive. The front panel power LED and power supply status output indicate when the power supply is operating. Power supply specifications are listed in the *Specifications* chapter.

## ***Target Indicators***

---

Target indicators are optional components selected when a relay is ordered. The electronically latched and reset targets consist of red LED indicators located on the relay front panel. A latched target is reset by operating the target reset switch on the front panel. If relay operating power is lost, any illuminated (latched) targets are extinguished. When relay operating power is restored, the previously latched targets are restored to their latched state.

A relay can be equipped with either internally operated targets or current operated targets.

### *Internally Operated Targets*

The relay trip outputs are directly applied to drive the appropriate target indicator. Each indicator is illuminated regardless of the current level in the trip circuit.

### *Current Operated Targets*

A current operated target is triggered by closure of the corresponding output contact and the presence of at least 200 milliamperes of current flowing in the trip circuit.

<b>Note</b>
Prior to September 2007, BE1-47N target indicators consisted of magnetically latched, disc indicators. These mechanically latched target indicators have been replaced by the electronically latched LED targets in use today.



## 4 • Installation

BE1-47N relays are shipped in sturdy cartons to prevent damage during transit. Upon receipt of a relay, check the model and style number against the requisition and packing list to see that they agree. Inspect the relay for shipping damage. If there is evidence of damage, file a claim with the carrier, and notify your sales representative or Basler Electric.

If the relay will not be installed immediately, store it in its original shipping carton in a moisture- and dust-free environment. Before placing the relay in service, it is recommended that the test procedures of the *Testing* chapter be performed.

### **Relay Operating Guidelines and Precautions**

---

Before installing or operating the relay, note the following guidelines and precautions.

- For proper current operated target operation, a minimum current of 200 milliamperes must flow through the output trip circuit.
- If a wiring insulation test is required, remove the connection plugs and withdraw the relay from its case.

#### **Caution**

When the connection plugs are removed, the relay is disconnected from the operating circuit and will not provide system protection. Always be sure that external operating (monitored) conditions are stable before removing a relay for inspection, test, or service.

#### **Notes**

Be sure that the relay is hard-wired to earth ground with no smaller than 12 AWG copper wire attached to the ground terminal on the rear of the case. When the relay is configured in a system with other devices, it is recommended to use a separate lead to the ground bus from each device.

It is recommended in all applications where contact outputs drive relay coils that a reverse biased diode be implemented in parallel with the relay coil for EMI suppression.

### **Mounting**

---

Because the relay is of solid-state design, it does not have to be mounted vertically. Any convenient mounting angle may be chosen.

Relay outline dimensions and panel drilling diagrams are shown in Figures 4-1 through 4-7. Dimensions are shown in inches with millimeters in parenthesis.

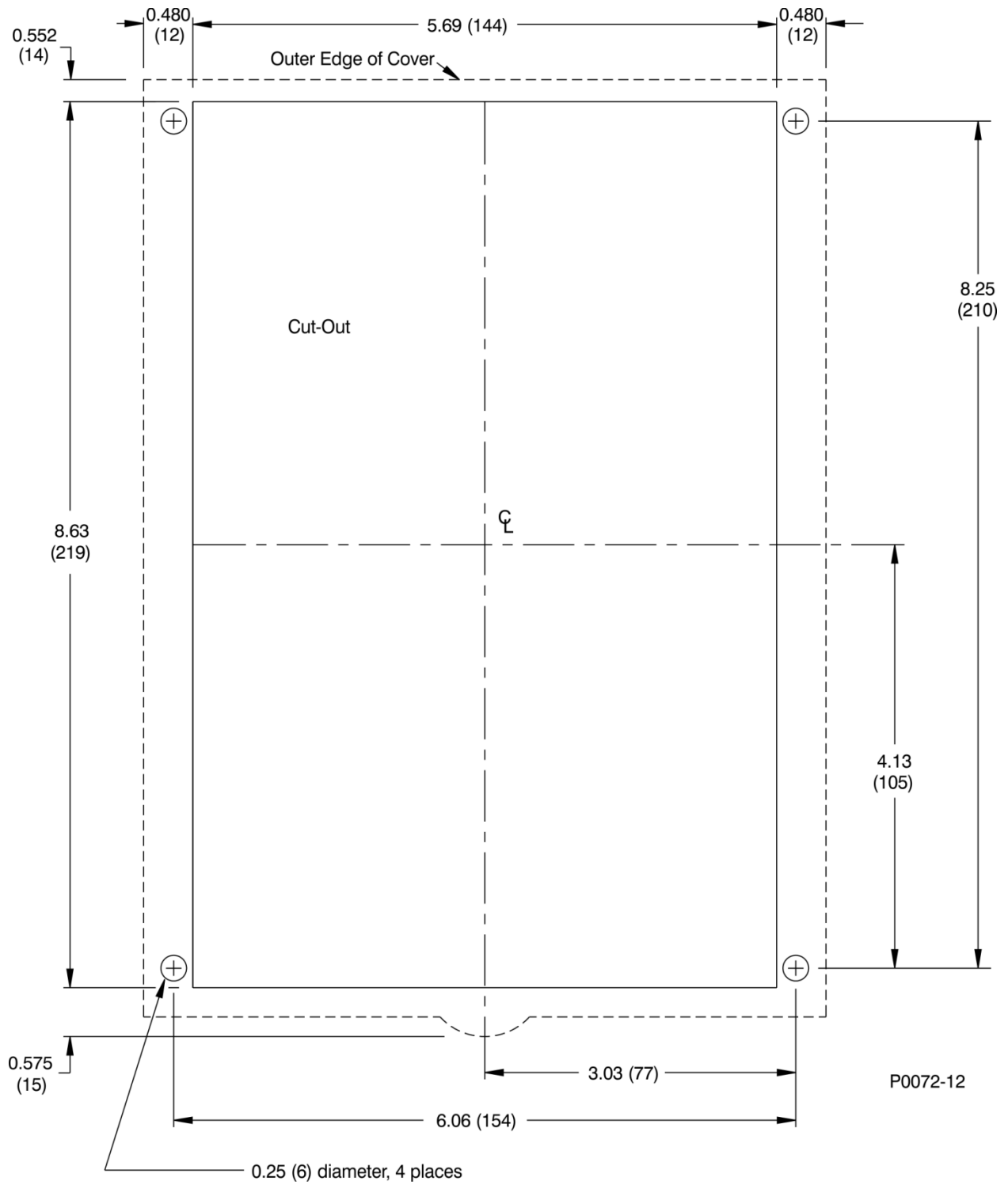

Figure 4-1. Panel Cutting/Drilling, Semi-Flush, S1 Case

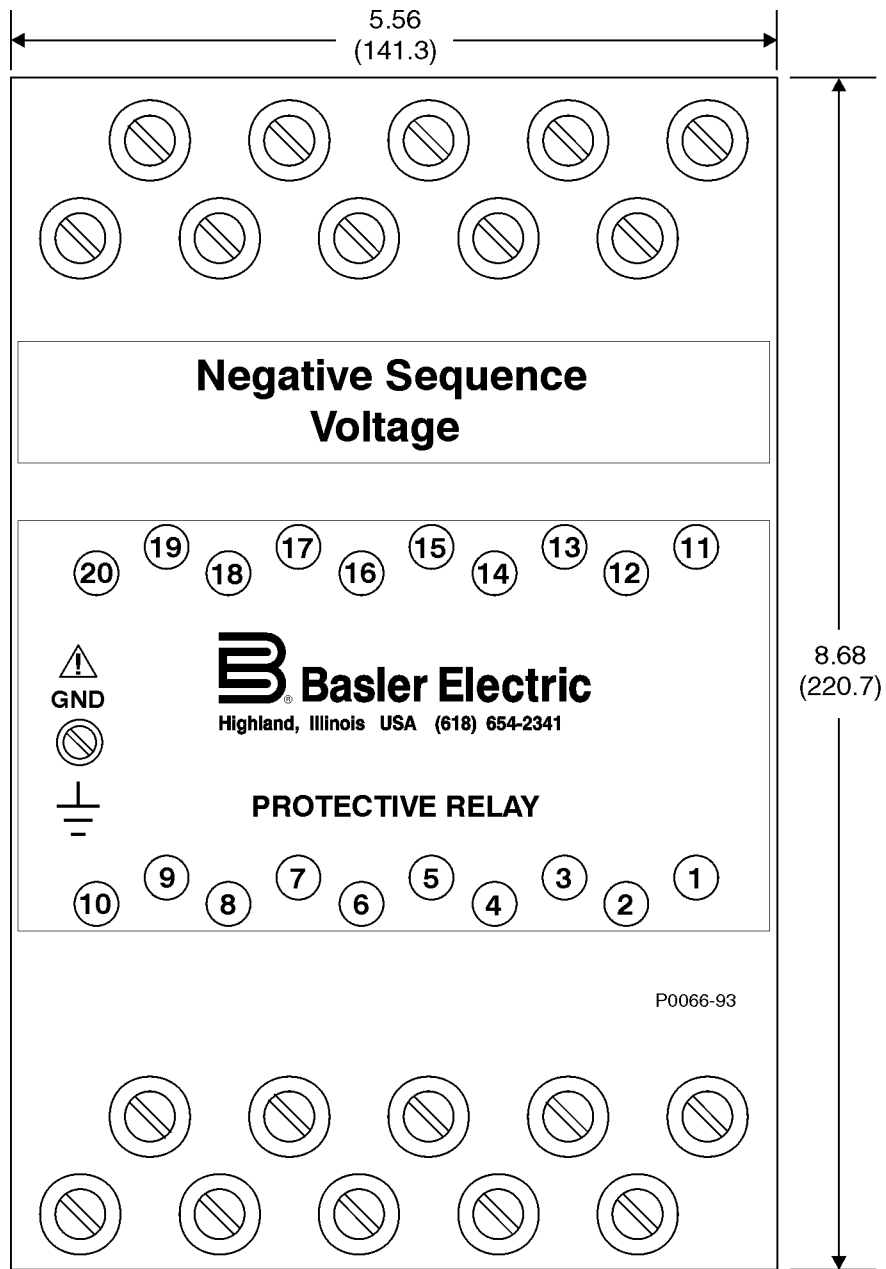

Figure 4-2. S1 Case Dimensions, Rear View, Double Ended, Semi-Flush Mount

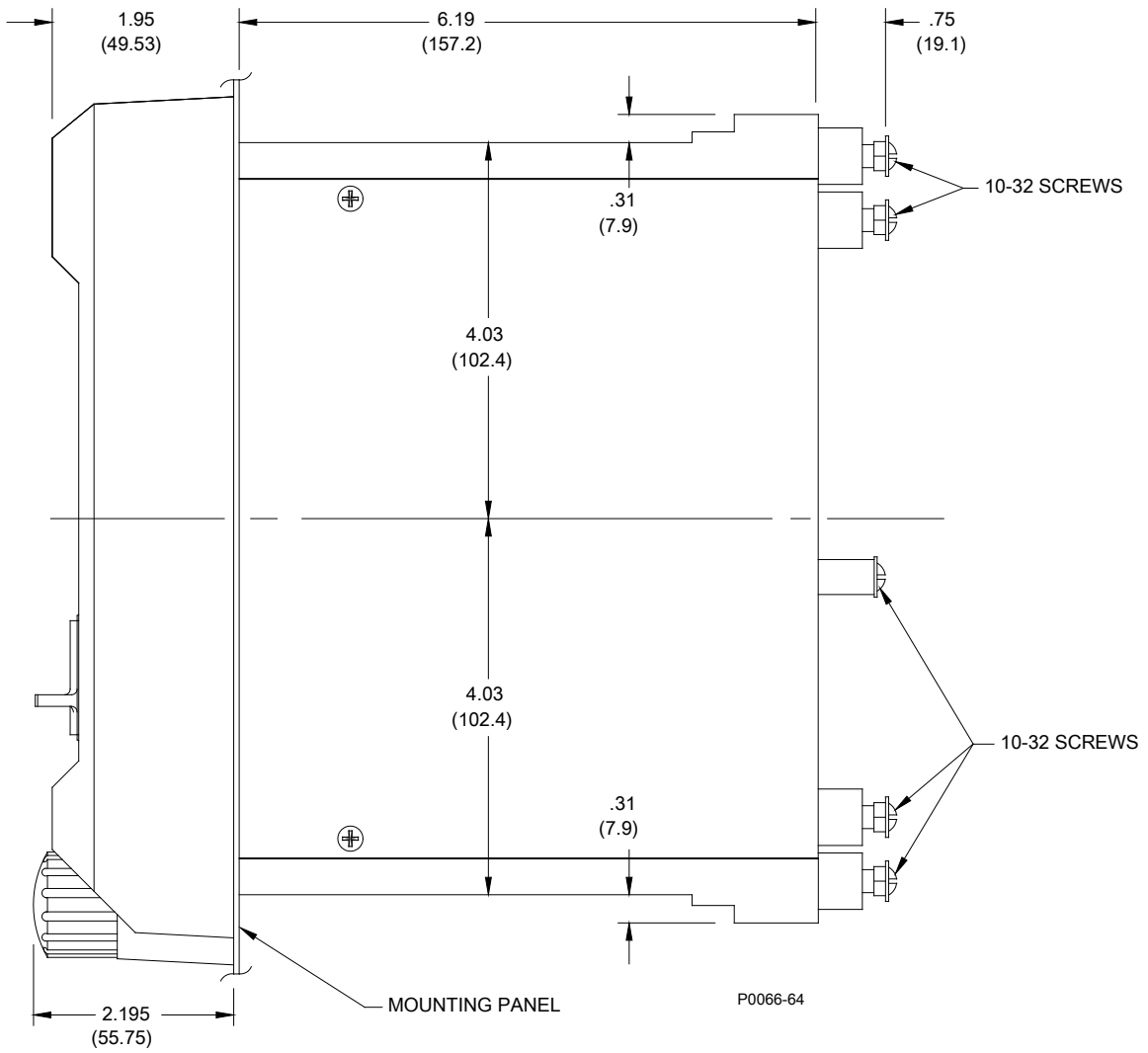

Figure 4-3. S1 Case Dimensions, Side View, Double Ended, Semi-Flush Mount

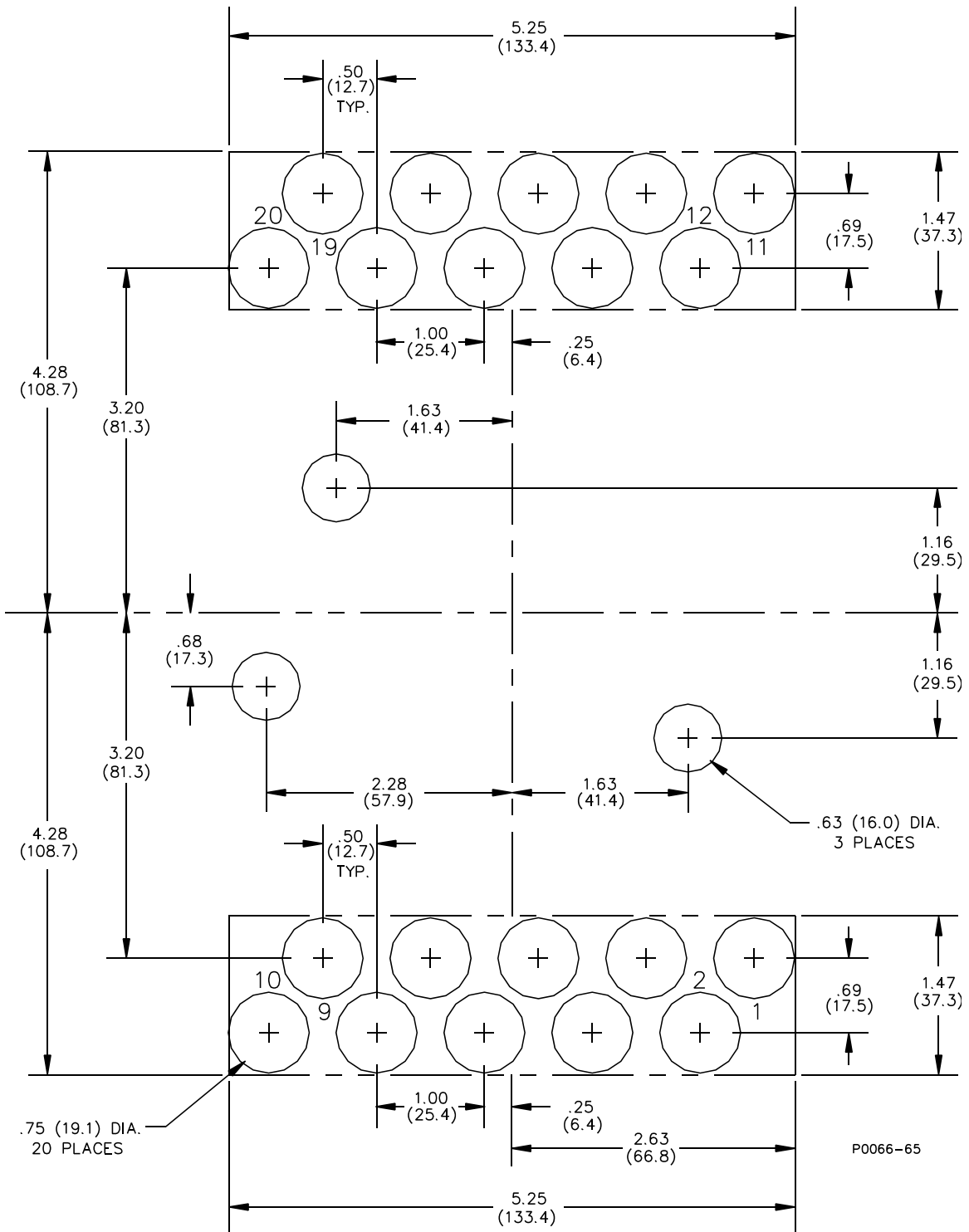

Figure 4-4. Panel Cutting/Drilling, Double Ended, Projection Mount S1 Case

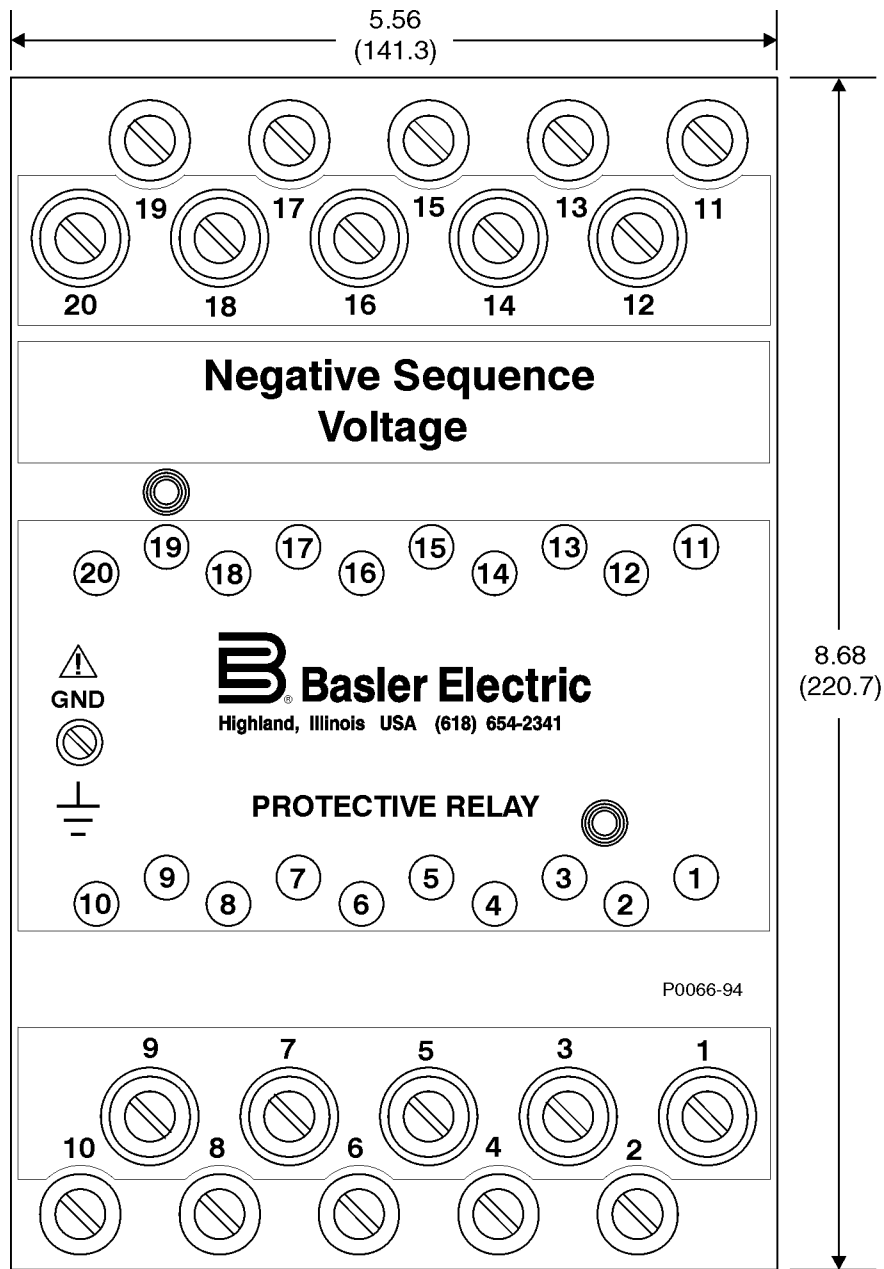

Figure 4-5. S1 Case Dimensions, Rear View, Double Ended, Projection Mount

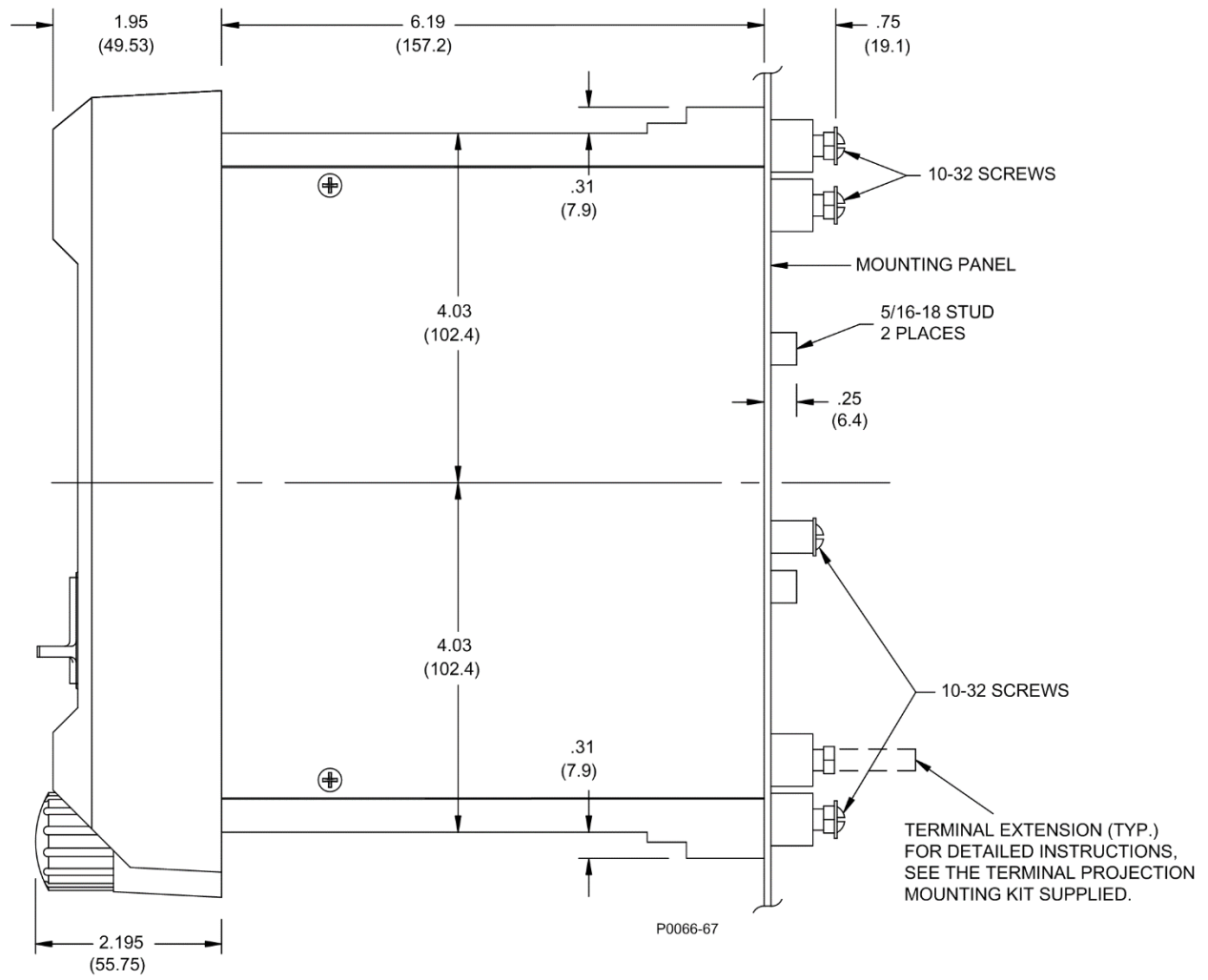

Figure 4-6. S1 Case Dimensions, Side View, Double Ended, Projection Mount

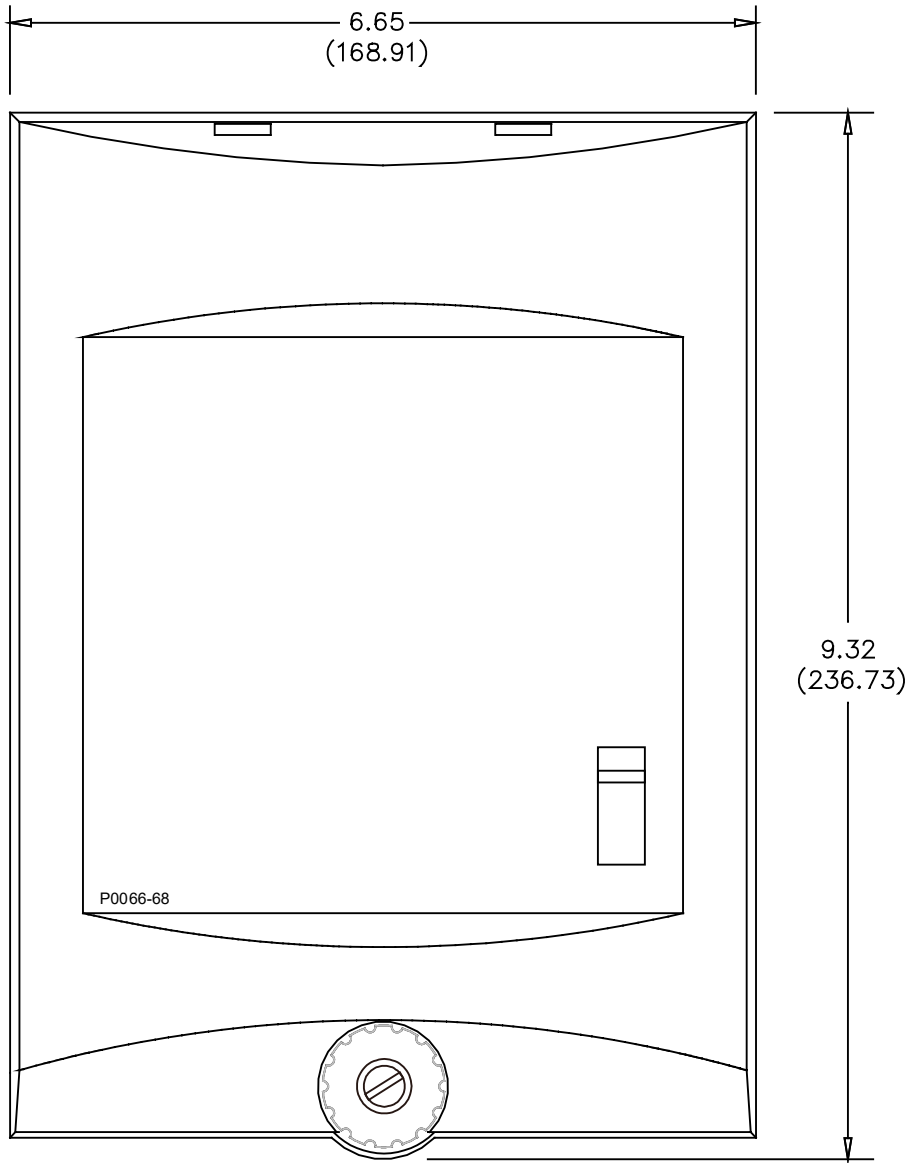

Figure 4-7. S1 Case Cover Dimensions, Front View

## Connections

Be sure to check the model and style number of a relay before connecting and energizing the relay. Incorrect wiring may result in damage to the relay. Except where noted, connections should be made with wire no smaller than 14 AWG.

Typical external connections are shown in Figures 4-8 and 4-9. Typical internal connections are shown in Figure 4-10.

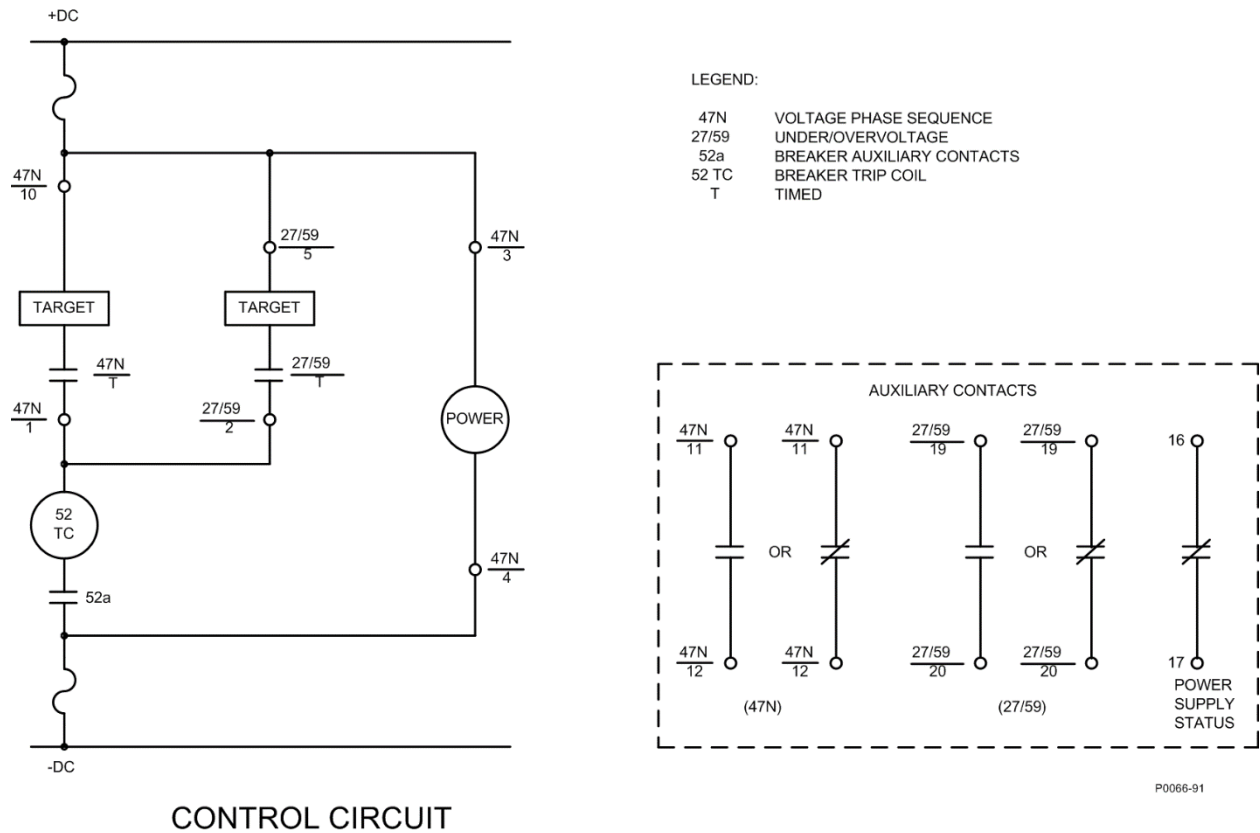

Figure 4-8. Control Circuit Diagram

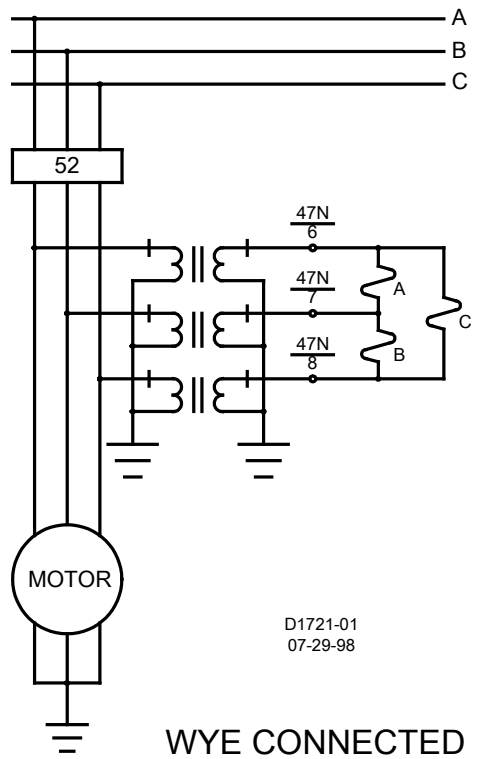
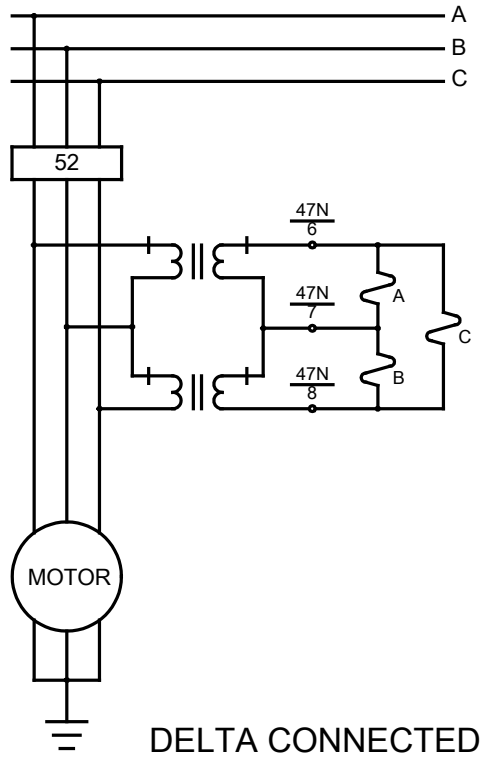

Figure 4-9. Sensing Input Connection

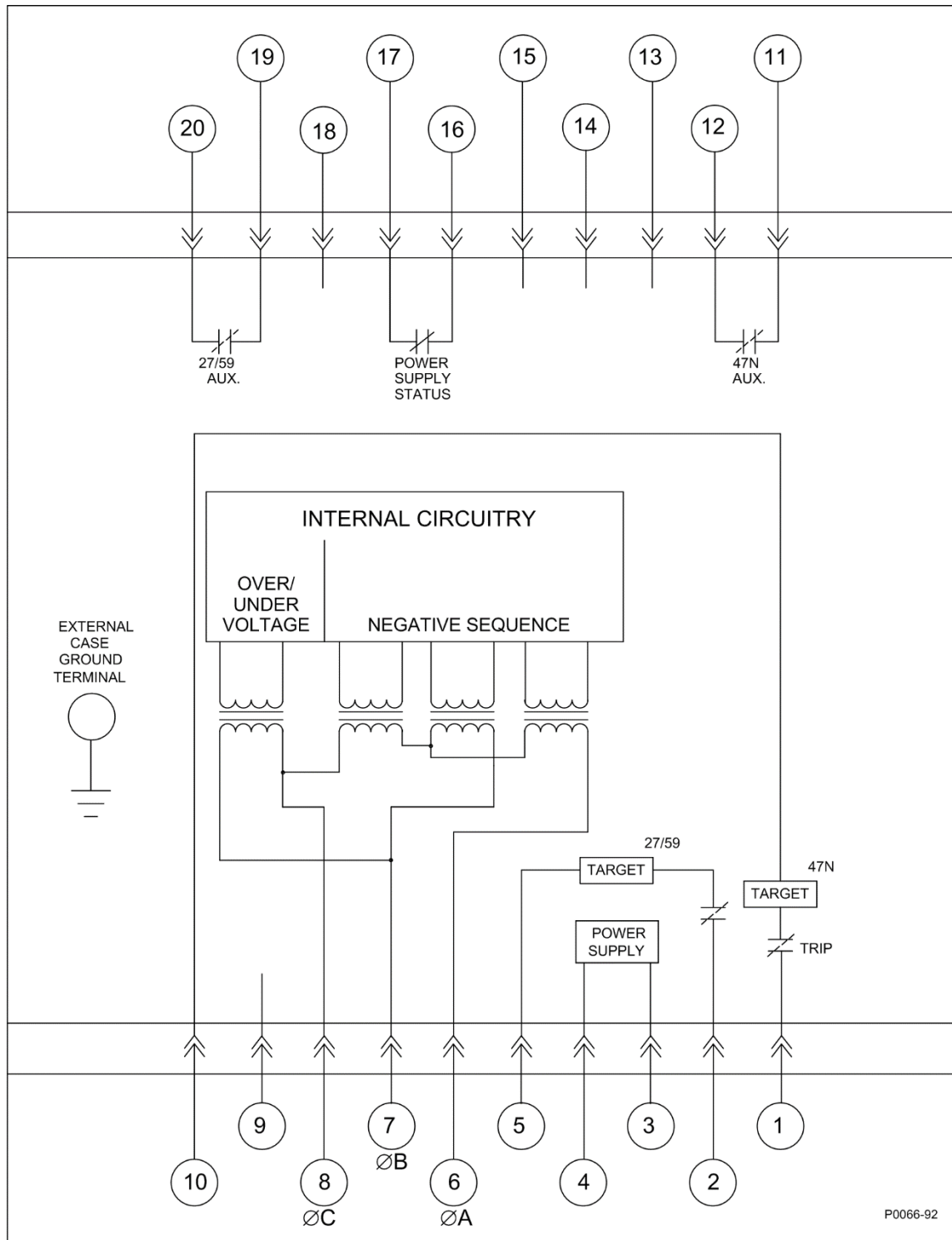

Figure 4-10. Typical Internal Connection Diagram

---

## ***Maintenance***

---

BE1-47N relays require no preventative maintenance other than a periodic operational check. If the relay fails to function properly, contact Technical Sales Support at Basler Electric to coordinate repairs.

## ***Storage***

---

This device contains long-life electrolytic capacitors. For devices that are not in service (spares in storage), the life of these capacitors can be maximized by energizing the device for 30 minutes once per year.

## 5 • Testing

The following procedures verify proper relay operation and calibration.

Results obtained from these procedures may not fall within specified tolerances. When evaluating results, consider three prominent factors:

- Test equipment accuracy
- Testing method
- External test set components tolerance level

### Operational Tests

Operational tests include pickup and dropout of negative sequence voltage protection, overvoltage protection, and undervoltage protection.

#### Negative Sequence Voltage Pickup and Dropout

BE1-47N accuracy verification requires a simultaneous test of the three phases. Such a comprehensive test involves careful monitoring of all phase voltages and phase angles, and the calculation of the negative sequence voltage values. However, it is possible to obtain confirmation of the essential integrity of the relay without resorting to methods that are more suited to a laboratory.

Accordingly, the following single-phase verification test is offered as an adequate accuracy and calibration test that is easy to set up and perform.

1. Adjust the Negative Sequence Pickup switch to the K (20%) position.
2. As shown in Figure 5-1, short-circuit or jumper case terminals 7 (B-phase) and 8 (C-phase).
3. Using Table 5-1 as a guide, apply voltage, at nominal frequency, to case terminal 6 (A-phase) and 7 (phases B and C). The Negative Sequence Pickup LED should light.

**Table 5-1. Negative-Sequence Test Voltage**

Sensing Input Range	Voltage Input
3) 120 Vac, 60 Hz	41.57 Vac ±2.08 Vac, 60 Hz
4) 100 Vac, 50 Hz	34.64 Vac ±1.73 Vac, 50 Hz
5) 208 Vac, 60 Hz	72.05 Vac ±3.60 Vac, 60 Hz
6) 173 Vac, 50 Hz	59.93 Vac ±3.00 Vac, 50 Hz

4. Vary the input to verify the setting.
5. Lower the input voltage until the pickup LED turns off. Record the input voltage. Dropout should be within 2% of the pickup value (i.e., input voltage at time of pickup, LED on).

Further pickup settings may be verified at this time. The following formulas determine the input voltages, based on sensing range, which will cause the pickup LED to light.

$$V_2 = \frac{1}{3} \left[ V_A + \alpha^2 V_B + \alpha V_C \right] \quad \text{where } \alpha = \angle 120^\circ$$

**Equation 5-1**

For line-to-line voltage:

$$V_{2LL} = \frac{1}{3} \left[ V_{AB} + \alpha^2 V_{BC} + \alpha V_{CA} \right]$$

**Equation 5-2**

If  $V_{BC} = 0$  Vac (Short phase B to Phase C)

Then  $V_{AB} = V_{AC} = -V_{CA}$  OR  $V_{CA} = -V_{AB} \angle 0^\circ = V_{AB} \angle 180^\circ$

Substituting into Equation 5-2:

$$\begin{aligned} V_{2LL} &= \frac{1}{3} [V_{AB} + \alpha^2(0) + \alpha(V_{AB} \angle 180^\circ)] \\ &= \frac{1}{3} V_{AB} [(1 \angle 0^\circ) + (1 \angle 120^\circ \times 1 \angle 180^\circ)] \\ &= \frac{1}{3} V_{AB} [(1 \angle 0^\circ) + (1 \angle 300^\circ)] \\ &= \frac{1}{3} [V_{AB} (\sqrt{3} \angle -30^\circ)] \\ &= \frac{V_{AB}}{\sqrt{3}} \angle -30^\circ \end{aligned}$$

$$V_{2PU} = \frac{V_{2LL}}{V_N} = \frac{V_{AB} \angle -30^\circ}{V_N \sqrt{3}}$$

**Equation 5-3**

Solving for  $V_{AB}$ :

$$\text{Magnitude } V_{AB} = V_{2PU} \times \sqrt{3} \times V_N$$

Where  $V_N = 120$  V for sensing input range 3 or 208 V for sensing input range 5

Example:

20%  $V_2 = 0.2$  per unit  $V_2 = 0.2$  per unit  $V_2$  (with phase B shorted to phase C)

For 120 V nominal,  $V_N = 120$

$$V_{AB} = (0.2)(\sqrt{3})(120)$$

$V_{AB} = 41.569$  Vac when phase input B is shorted to C

6. Test the other phases by repeating the previous steps while shorting different phase pairs.

### Overvoltage Pickup and Dropout

1. Adjust the Overvoltage Pickup switch to the E (10%) position.
2. Apply 1.10 times the nominal input voltage (110%) across case terminals 7 (B-phase) and 8 (C-phase). The Overvoltage Pickup LED should light.
3. Vary the input voltage to confirm the pickup value.
4. Lower the input voltage until the Overvoltage Pickup LED turns off. Record the input value. Dropout should be within 2.0% of the pickup value (i.e., input voltage at time of pickup, LED on).

## Undervoltage Pickup and Dropout

1. Adjust the Undervoltage Pickup switch to the E (10%) position.
2. Apply 0.90 times the nominal input voltage (90%) across case terminals 7 (B-phase) and 8 (C-phase). The Undervoltage Pickup LED should light.
3. Vary the input voltage to confirm the pickup value.
4. Raise the input voltage until the Undervoltage Pickup LED turns off. Record the input value. Dropout should be within 2.0% of the pickup value (i.e., input voltage at time of pickup, LED on).

## Verification Tests

Verification tests consist of definite time verification and inverse time verification.

### Definite Time Verification

The definite time circuitry for the negative sequence voltage (47N), overvoltage (59), and undervoltage (27) functions operates similarly and can be tested using the same philosophy. In order to reduce the amount of redundant procedural steps, only the overvoltage function is addressed here.

1. Connect the test setup as indicated in Figure 5-2.
2. Adjust the Overvoltage Time Delay switch to 33.
3. Adjust the Overvoltage Pickup switch to the A (2%) position.
4. Connect the voltage source to case terminals 7 (A-phase) and 8 (C-phase) and adjust the voltage source to 1.20 times the nominal input value (120%).
5. Close switch S1 to initiate the timer. The Overvoltage Pickup LED will light and the timer should time out at 3.3 seconds  $\pm 5\%$ .

### Inverse Time Verification

Due to the similarities in inverse timing for the functions of this relay, only the negative sequence function is addressed here. The remaining functions can be verified using the same test philosophy.

1. Connect the test setup as indicated in Figure 5-1.
2. Adjust the Negative Sequence Pickup switch to the B (4%) position. Adjust the Negative Sequence Time Delay switch to 10.
3. Short or jumper case terminals 7 (B-phase) and 8 (C-phase).
4. Using Table 5-2 as a guide, apply voltage at case terminals 6 (A-phase) and 7 (C-phase). Note that the input voltage values are two times the actual pickup value.

**Table 5-2. Inverse Time Test Voltage**

Sensing Input Range	Voltage Input
3) 120 Vac, 60 Hz	16.628 Vac $\pm 0.17$ Vac, 60 Hz
4) 100 Vac, 50 Hz	13.856 Vac $\pm 0.14$ Vac, 50 Hz
5) 208 Vac, 60 Hz	28.80 Vac $\pm 0.29$ Vac, 60 Hz
6) 173 Vac, 50 Hz	24.00 Vac $\pm 0.24$ Vac, 50 Hz

5. Measure and record the interval from initiate to contact closure at case terminals 1 and 10. The 47N inverse time should be 5.96  $\pm 0.298$  seconds.

Further points on the inverse time curves may be verified using the same philosophy. Input voltage values for pickup may be obtained using the equations mentioned previously.

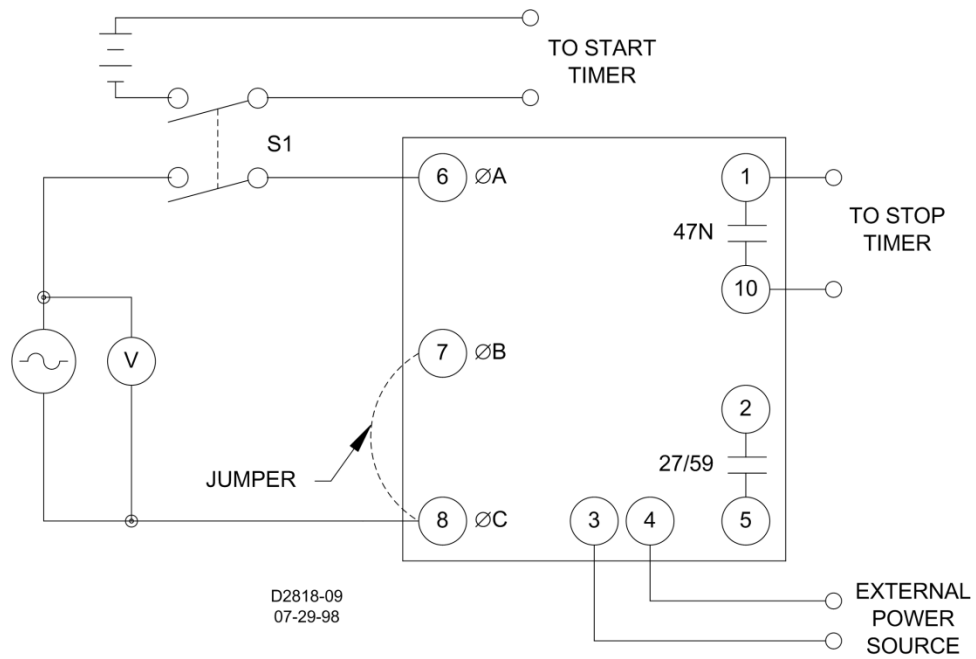

Figure 5-1. Test Circuit Diagram (47N)

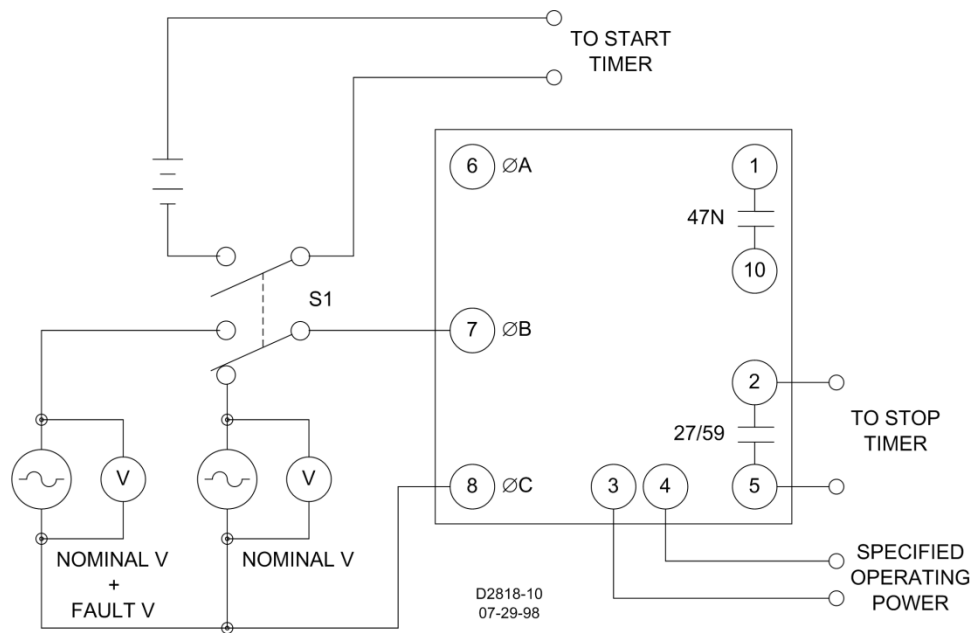

Figure 5-2. Test Circuit Diagram (27, 59)



## Negative Sequence Voltage

---

### Pickup

Setting Range ..... 2 to 32% of nominal voltage  
 Increment ..... 2%  
 Accuracy.....  $\pm 1\%$  of nominal voltage

### Dropout

98% of pickup

### Time Delay

#### Definite

Setting Range ..... 0.1 to 9.9 s  
 Increment ..... 0.1 s  
 Accuracy.....  $\pm 5\%$  or  $\pm 50$  ms of the time setting

#### Inverse

Setting Range ..... 01 to 99  
 Increment ..... 1  
 Accuracy.....  $\pm 5\%$  or  $\pm 50$  ms of the indicated time of the selected time dial curve illustrated in the *Functional Description* chapter

#### Instantaneous

Delay ..... < 50 ms

## Undervoltage

---

### Pickup

Pickup Setting Range..... 2 to 32% of nominal  
 Pickup Increment ..... 2%  
 Pickup Accuracy.....  $\pm 1\%$  of the pickup setting

### Dropout

102% of pickup

### Time Delay

#### Definite

Setting Range ..... 0.1 to 9.9 s  
 Increment ..... 0.1 s  
 Accuracy.....  $\pm 5\%$  of the time setting

#### Inverse

Setting Range ..... 01 to 99  
 Increment ..... 1  
 Accuracy.....  $\pm 5\%$  or  $\pm 50$  ms of the indicated time of the selected time dial curve illustrated in the *Functional Description* chapter

#### Instantaneous

Delay ..... < 50 ms

## Overvoltage

---

### Pickup

Pickup Setting Range.....	2 to 32% of nominal
Pickup Increment .....	2%
Pickup Accuracy.....	±1% of the pickup setting

### Dropout

98% of pickup

### Time Delay

#### Definite

Setting Range .....	0.1 to 9.9 s
Increment .....	0.1 s
Accuracy.....	±5% of the time setting

#### Inverse

Setting Range .....	01 to 99
Increment .....	1
Accuracy.....	±5% or ±50 ms of the indicated time of the selected time dial curve illustrated in the <i>Functional Description</i> chapter

#### Instantaneous

Delay .....	< 50 ms
-------------	---------

## Output Contacts

---

### Resistive Ratings

120 Vac .....	Make, break, and carry 7 Aac continuously
250 Vdc .....	Make and carry 30 Adc for 0.2 s, carry 7 Adc continuously, break 0.3 Adc
500 Vdc .....	Make and carry 15 Adc for 0.2 s, carry 7 Adc continuously, break 0.3 Adc

### Inductive Ratings

120 Vac, 125 Vdc, 250 Vdc.....	Break 0.3 A (L/R = 0.04)
--------------------------------	--------------------------

## Type Tests

---

Shock .....	Withstands 15 G in each of three mutually perpendicular planes without structural damage or performance degradation.
Vibration .....	Withstands 2 G in each of three mutually perpendicular planes, swept over the range of 10 to 500 Hz for a total of six sweeps, 15 minutes each sweep, without structural damage or degradation of performance.
Dielectric Strength.....	Tested in accordance with IEC 255-5 and IEEE C37.90. All circuits to ground: 2,121 Vdc applied for 1 min Input to output circuits: 1,500 Vac or 2,121 Vdc applied for 1 min
Radio Frequency Interference .....	Maintains proper operation when tested for interference in accordance with IEEE C37.90.2-1987, <i>Standard Withstand Capability of Relay Systems to Radiated Electromagnetic Interference from Transceivers</i> .

---

Surge Withstand Capability.....	Qualified to IEEE C37.90.1-1989, <i>Standard Surge Withstand Capability (SWC) Tests for Protective Relays and Relay Systems.</i>
Fast Transient .....	Qualified to IEEE C37.90.1-1989
Impulse.....	Qualified to IEC 255-5

## ***Physical***

---

### **Temperature**

Operating Range .....	-40 to 70°C (-40 to 158°F)
Storage Range .....	-65 to 100°C (-85 to 212°F)

### **Weight**

14 lb (6.35 kg)

### **Case Size**

S1 (Refer to the *Installation* chapter for case dimensions.)

## ***UL Recognition***

---

UL recognized per Standard 508, File E97033.

Note: Output contacts are not UL recognized for voltages greater than 250 volts.



 **Basler Electric®**  
**www.basler.com**

12570 Route 143  
Highland IL 62249-1074 USA  
Tel: +1 618.654.2341  
Fax: +1 618.654.2351  
email: [info@basler.com](mailto:info@basler.com)

No. 59 Heshun Road Loufeng District (N)  
Suzhou Industrial Park  
215122 Suzhou  
P.R. CHINA  
Tel: +86 512.8227.2888  
Fax: +86 512.8227.2887  
email: [chinainfo@basler.com](mailto:chinainfo@basler.com)

111 North Bridge Road  
15-06 Peninsula Plaza  
Singapore 179098  
Tel: +65 68.44.6445  
Fax: +65 68.44.8902  
email: [singaporeinfo@basler.com](mailto:singaporeinfo@basler.com)