

INSTRUCTION MANUAL

FOR

LOW PROFILE SYNC-CHECK RECLOSING RELAY

BE1-25/79TR

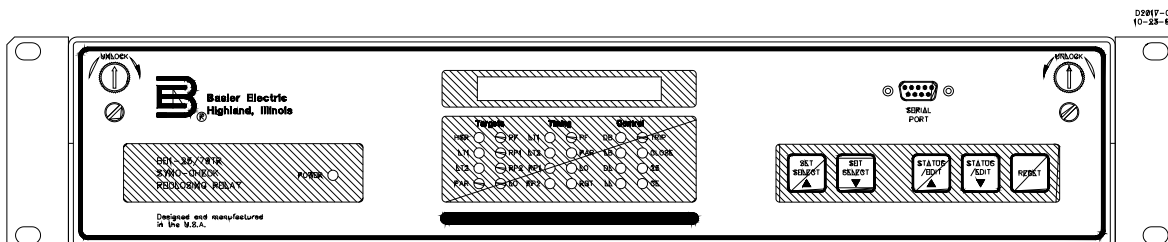

Publication: 9278700990

Revision: C 08/17

INTRODUCTION

This manual provides information concerning the operation of BE1-25/79TR Sync-Check Reclosing Relays. To accomplish this, the following information is provided.

- General Information
- Functional Description
- Installation Information
- Calibration and Testing Procedures

WARNING!

To avoid personal injury or equipment damage, only qualified personnel should perform the procedures presented in this manual.

NOTE

Be sure the relay is hard-wired to earth ground with no smaller than 12 AWG copper wire attached to the ground terminal on the rear of the relay case. When the relay is configured in a system with other protective devices, it is recommended to use a separate lead to the ground bus from each relay.



12570 State Route 143
Highland IL 62249-1074 USA

www.basler.com

Info@basler.com

Tel: +1 618.654.2341

Fax: +1 618.654.2351

© 2017 by Basler Electric

All rights reserved

First printing: October 1994

WARNING!

READ THIS MANUAL. Read this manual before installing, operating, or maintaining the BE1-25/79TR. Note all warnings, cautions, and notes in this manual as well as on the product. Keep this manual with the product for reference. Only qualified personnel should install, operate, or service this system. Failure to follow warning and cautionary labels may result in personal injury or property damage. Exercise caution at all times.

Basler Electric does not assume any responsibility to compliance or noncompliance with national code, local code, or any other applicable code. This manual serves as reference material that must be well understood prior to installation, operation, or maintenance.

For terms of service relating to this product and software, see the Commercial Terms of Products and Services document available at www.basler.com/terms.

This publication contains confidential information of Basler Electric Company, an Illinois corporation. It is loaned for confidential use, subject to return on request, and with the mutual understanding that it will not be used in any manner detrimental to the interests of Basler Electric Company and used strictly for the purpose intended.

It is not the intention of this manual to cover all details and variations in equipment, nor does this manual provide data for every possible contingency regarding installation or operation. The availability and design of all features and options are subject to modification without notice. Over time, improvements and revisions may be made to this publication. Before performing any of the following procedures, contact Basler Electric for the latest revision of this manual.

The English-language version of this manual serves as the only approved manual version.

CONTENTS

Section 1	GENERAL INFORMATION	1-1
	Description	1-1
	Capabilities	1-1
	Reclosing	1-1
	Sync-Check	1-1
	Voltage Monitor	1-1
	Tripping	1-1
	Control Inputs	1-2
	Enable Inputs	1-2
	Timers	1-2
	Indicators	1-2
	Communications	1-2
	Timing Functions	1-3
	Control Inputs	1-3
	Reclosing	1-3
	Tripping	1-4
	Outputs	1-5
	Control	1-5
	Alarm	1-5
	Application	1-5
	General	1-5
	Reclosing Example	1-6
	Bus D or Transformer T1 Faults and Clears	1-9
	Bus D or Transformer T1 Faults and Fails to Clears	1-9
	Bus E or Transformer T2 Faults and Fails to Clears	1-9
	Model Numbers	1-10
	Specifications	1-11
Section 2	CONTROLS AND INDICATORS	2-1
Section 3	FUNCTIONAL DESCRIPTION	3-1
	General	3-1
	Block Diagram Analysis	3-1
	Output/Magnetics Board	3-1
	Input/Logic Board	3-1
	Power Supply	3-1
	Modes of Operation	3-3
	Settings Mode	3-3
	Status Mode	3-4
	Reclosing Functional Description	3-5
	High Speed Reclose	3-5
	Parallel	3-5
	Restore Power	3-5
	Line Test	3-5
	Sync-Check Function Description	3-6
	Sync-Check	3-6
	Voltage Difference	3-7

CONTENTS - Continued

Section 3

FUNCTIONAL DESCRIPTION - Continued

Voltage Monitor	3-7
Slip Frequency Difference	3-9
Tripping Function, Power Fail	3-9
Control Functions	3-9
Counter Enable	3-9
Drive to Lockout	3-9
Drive to Reset	3-9
Timing Functions	3-9
Master Timer	3-9
Reset Timers	3-10
Lockout Timer	3-10
Reclose Timers	3-10
HSR Timer	3-10
Sync-Check Timer	3-10
PF Timer	3-10
Close TD Timer	3-10
Loss Of Potential Timer	3-10
Selection Functions	3-11
HSR Sync	3-11
Start 52b	3-11
Communications	3-11
General	3-11
RS232-C Format	3-11
Serial Port Connections and Configurations	3-12
Serial Communication	3-13
Starting Communication	3-13
Main Menu and Activities	3-14

Section 4

INSTALLATION

4-1

General	4-1
Operation Precautions	4-1
Dielectric Test	4-1
Mounting	4-2
General	4-2
Installing Escutcheon Plates	4-4
Connections	4-5

Section 5

TESTING

5-1

General	5-1
Testing	5-1
Preliminary Setup Procedures	5-1
Time, Date, Settings, and Save	5-6
Timers	5-6
Control Inputs	5-8
Voltage Monitor	5-10
Voltage Difference Inhibit	5-10

CONTENTS - Continued

Section 5	TESTING - Continued	
	Sync LB and LL Inhibit	5-10
	Phase Accept	5-10
	Slip Frequency Difference	5-11
	Programmable Outputs	5-11
	Calibration	5-12
	Self Test	5-13
	Loading Factory Default Settings	5-15
Section 6	MAINTENANCE	6-1
	General	6-1
	In-House Repair	6-1
	Storage	6-1
Section 7	CHANGE INFORMATION	7-1

SECTION 1

GENERAL INFORMATION

DESCRIPTION

BE1-25/79TR Sync-Check Reclosing Relays are microprocessor based relays that provide automatic reclosing for transmission line systems, utility interties, and distribution systems with cogeneration. BE1-25/79TR relays provide one or two shot reclosing capabilities with sync-check and voltage monitoring functions. To provide the required and perhaps changing characteristics for your specific system, the BE1-25/79TR relays are field programmable via contact sensing inputs. Relay timing is programmed using the relay front panel mounted switches and visual display or remotely using communication ports mounted on the front and rear panels. Communication through the front and rear ports requires a remote computer with modem software. These capabilities are required to fully automate your transmission line system.

CAPABILITIES

BE1-25/79TR relays are similar in principle to mechanical repeat cycle timers where various operations are permitted as the cam is rotated. The capabilities of this relay are equivalent to and exceed mechanical relays used in automated transmission line systems. BE1-25/79TR relays have the following capabilities.

Reclosing

- One or two shots.
- High speed reclose (in cycles) and high speed reclose with sync-check supervision.
- Parallel (live line/live bus) and parallel with sync-check and voltage monitor.
- Restore power (live line and dead bus).
- Line test (dead line and live bus).

Sync-Check

- Checks phase angle between line and bus.
- Phase window setting.
- Slip frequency window setting.
- Independent of reclosing sequence.

Voltage Monitor

- Live line.
- Dead line.
- Live bus.
- Dead bus.
- Delta voltage.

Tripping

- Trip breaker when both line and bus are dead (power fail condition).
- Trip function enabled by power fail (PF) external contact sensing input.

BE1-25/79TR General Information

Control Inputs (External Contact Sensing Inputs)

- CE - Master timer enable(enables or freeze all timers).
- DTL - Drive to lockout.
- DTR - Drive to reset.
- PF - Power fail tripping enable/disable.
- BLK - Block high speed reclose for three-phase faults.

Enable Inputs (External Contact Sensing Inputs)

- LT1 - Line test one.
- LT2 - Line test two.
- RP1 - Restore power one.
- RP2 - Restore power two.
- PAR - Parallel.
- 52b - Breaker b seal.
- HSR - High speed reclose.

Timers

- MASTER - Window for reclosing sequence.
- RST1, RST2 - Reset timers.
- LO - Lockout timer for failed reclose.
- LT1, LT2, RP1, RP2, PAR - Reclose timers.
- HSR - High speed reclose timer.
- SYNC - Sync-check timer.
- PF - Dead line and bus condition timer.
- LOP - Loss of potential with closed breaker.

Indicators

There are five indicator types or categories and all are mounted on the front panel.

- Visual Display - Twelve character display to monitor function, status, and settings.
- Targets - Eight red LEDs.
- Control - Four yellow LEDs.
- Timing - Seven green LEDs.
- Status - One green and four yellow LEDs.

Communications

Communication through front or rear panel mounted RS 232-C connectors requires a remote computer with modem software in a VT-100 compatible terminal mode. Communication allows a remote or local user to view current internal relay parameters (parameters in this case refer to the operational status of specific components such as RAM, ROM, power supply, voltage magnitudes and sync check parameters), select relay settings, review and reset event record reports data, and view both summary and detailed reports. Figure 1-1 shows the menu driven flow diagram paths and the required keystrokes to enter and exit each screen. Main activities (screens) are:

- Diagnostics (password protected)
- Programmable outputs
- Review/edit settings (password protected)
- Review/reset maintenance values
- Reports

BE1-25/79TR General Information

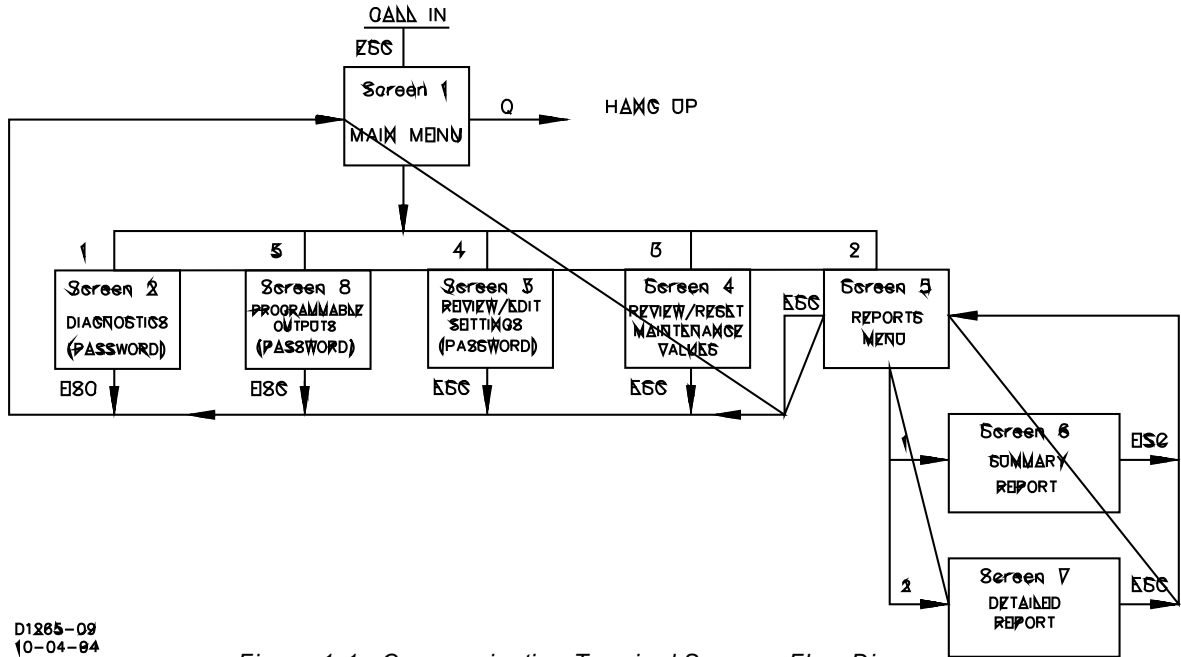

Figure 1-1. Communication Terminal Screens Flow Diagram

TIMING FUNCTIONS

Control Inputs

Some control inputs (external contact sensing inputs) are associated with both control and timing and may be used to enable or disable relay functions. An open CE contact sensing input freezes all timers. When the CE input is closed, the timers resume timing. When PF contact sensing input is closed (enabled), the breaker is closed (52b open), and both bus and line voltages are dead, PF timing is initiated. When BLK contact sensing input is closed, high speed reclosing attempts are blocked. When the DTL or DTR input is closed, the relay is driven to lockout (DTL) or reset (DTR).

Reclosing

Timing for reclosing begins when either the breaker opens (52b closes) with an initiate contact input (LT1, LT2, RP1, RP2, or PAR) closed or the high speed reclose (HSR) input closes momentarily (refer to Figure 1-2 for timing relationships). Either of these conditions cause the master timer and all reclose timers to begin timing. The setting START 52b allows the master timer and reclose timers to start timing only on 52b closing without an additional initiate contact input closed.

Master timing defines a period of time (window) that a reclose output may be given. One or more reclosings may be initiated if reclose timers time out during the master timing window. Timer durations are established by programming the relay using the front panel mounted switches and visual display.

Reclose action occurs when the conditions for reclose are satisfied and the particular reclose timer times out. Conditions associated with each reclose timer are established during setup. They include live or dead

conditions on the line and bus and also the status of the breaker. PAR reclose timer also includes conditions for delta voltage and phase angle across the open breaker.

BE1-25/79TR General Information

A failed reclose can be detected when the breaker does not open (52b stays closed) after the breaker operate time (CLOSE TD setting) and the Lockout Timer time delay expire (see Figure 1-3). If 52b does not open (indicating a unsuccessful reclose) before the Lockout Timer expires, the relay will go to lockout. At that time, the breaker must be closed manually.

After the master timer expires, the status of the breaker (52b contact) is checked. If the breaker remains closed for the time established for RST1 timer, then the relay is reset.

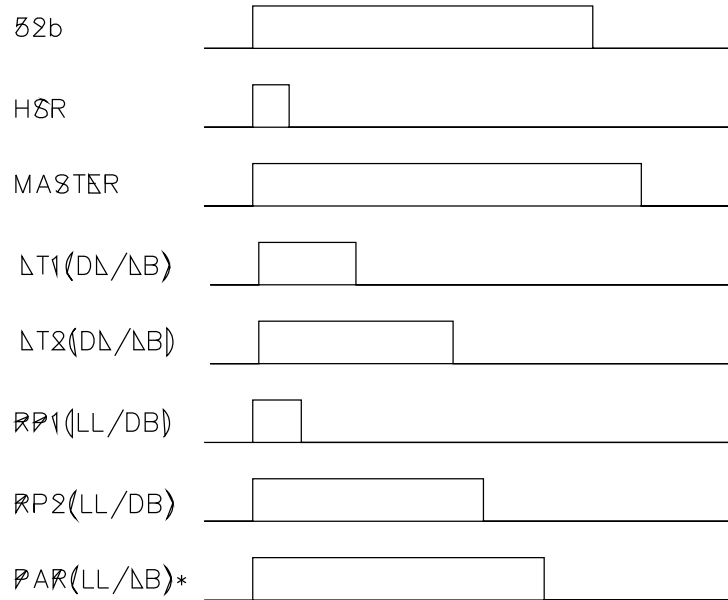

* Synchronizing provisions with phase angle and $\Delta\Delta/\Delta B$ voltages.

Figure 1-2. PAR (LL/LB) Reclosing Timing Chart ^{D1485-10}₇₋₃₋₉₅

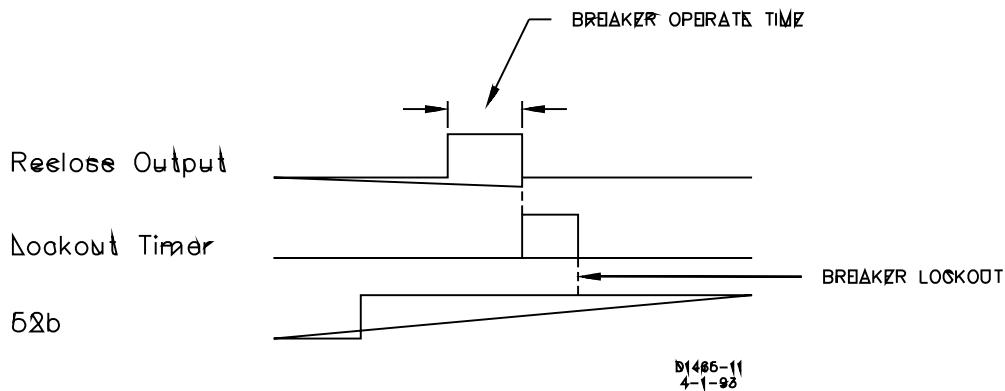

Figure 1-3. Failed Reclose Lockout Timing Chart ^{D1485-11}₄₋₁₋₉₃

Tripping

Power Fail timing is initiated when both line and bus are dead, PF contact sensing input is closed (enabled), and the breaker is closed. If these conditions remain after the PF timer expires, a trip output is issued. If the breaker is opened externally with a dead line and dead bus condition, all enabled timers will be frozen until the breaker is closed manually or until any voltage potential is reapplied.

OUTPUTS

Control

Form A output contacts (CLOSE) provide for closing of the breaker during the reclose sequence. The maximum duration for the CLOSE output is determined by the CLOSE TD setting adjustable from 1 to 999 seconds in one setting increments.

Form A output contacts (TRIP) are provided to trip the breaker for a dead line and dead bus condition when the power fail feature is selected.

Form A output contacts (SYNC) are provided for sync-check/voltage monitor functions. When the phase angle and voltage are within the limits set for permitting a reclosure and the sync time delay setting (adjustable from 1 to 999 cycles in one cycle increments) expires, the sync output contacts close. This output may be used to supervise other devices in the station and is independent of the master timer.

N.O. or N.C. selectable memory output contacts are provided for LT1, LT2, RP1, and RP2. When a reclose occurs, the associated relay is energized and latched. The relay remains latched until the reclosing sequence returns to reset. These outputs are used in logic schemes requiring more than one BE1-25/79TR to test the bus. These four outputs may be redefined to indicate live or dead voltage monitor conditions.

Alarm

Three Form A programmable output contacts (PROG1, PROG2, and PROG3) are provided to indicate system voltage conditions, loss of potential, Lockout, reclosing in progress, parallel and high speed reclosing targets.

Form B output contacts are provided for a relay trouble alarm (RT ALM). RT ALM contacts are held open unless there is a power supply failure or an internal microprocessor failure.

APPLICATION

General

BE1-25/79TR relays are suitable for use in any automatic transmission reclosing system. BE1-25/79TR relays could also be used in distribution applications even though the full capabilities of the relay would not be used.

Parallel with sync-check supervision is a high speed function suitable for blocking high speed reclosing on out-of-step conditions. This application can be used on transmission lines connected to generation systems. By delaying the reclosing on one end until the other end has energized the line, the phase angle of the voltages can be compared. If the angle exceeds a phase window value, the high speed reclosing (and paralleling) can be blocked.

BE1-25/79TR relays can be programmed to operate with the breaker open for a live line/live bus condition and the parallel function disabled.

With a dead line and dead bus condition, the power failure function can be used to trip the breaker and freeze any reclose timing in progress.

Added versatility for the relay is provided by the counter enable input. This contact sensing input interrupts and freezes the reclose timers any time this input is opened regardless of voltage monitor conditions.

BE1-25/79TR General Information

Reclosing Example

Automated reclosing applications can be as simple or complex as your particular station requires. All connections between BE1-25/79TR relays, monitoring inputs, and contact sensing inputs are not shown in our example.

Our example, Figures 1-4 illustrates a typical three transformer looped station automated reclosing application. In this example, four BE1-25/79TR relays are used. BE1-25/79TR relay number 1 is connected across breaker 52-1 (Line 1 potential transformer (PT) feeds the relay line input and bus D PT feeds the relay bus input). BE1-25/79TR relay number 2 is connected in a similar manner for breaker 52-2. BE1-25/79TR relay number 3 is connected to motor operated switch 89-4 with bus D PT feeding the line input and bus E PT feeding the bus input. BE1-25/79TR relay number 4 is connected in a similar manner for motor operated switch 89-5, Bus F, and Bus E. When reclosing 89-4 and 89-5, 89-4 is set to close first. Figures 1-5 through 1-8 illustrate connections for the four BE1-25/79TR relays in our example application.

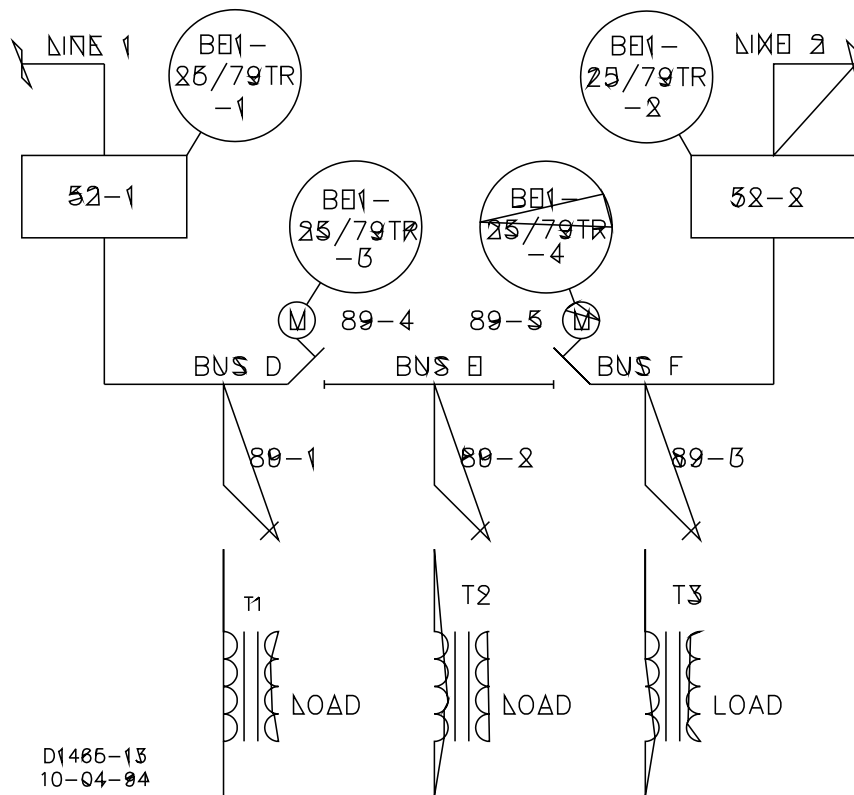

Figure 1-4. Loop Station Application Example

Legend (for Figures 1-5 through 1-8)

43/A-Auto/Manual Switch	43C/ON-Carrier Switch ON
52b-Breaker Position	86-Lockout Relay
94-Aux Tripping Relay	BLK- Block High Speed Reclose
CE-Master Timer Enable	F/FCC-Power Fail Feature Cut-Out
H/FCC-High Speed Feature Cut-Out	HRC- High Speed Reclose Cancel
HRI-High Speed Reclose Initiate	HSR-High Speed Reclose Enable
LT1-First Line Test Enable	P/FCC-Parallel Feature Cut-Out
PAR-Parallel Enable	PF-Power Failure Enable
R/FCC-Restore Feature Cut-Out	RP1-First Restore Power Enable
T/FCC-Test Feature Cut-Out	

BE1-25/79TR General Information

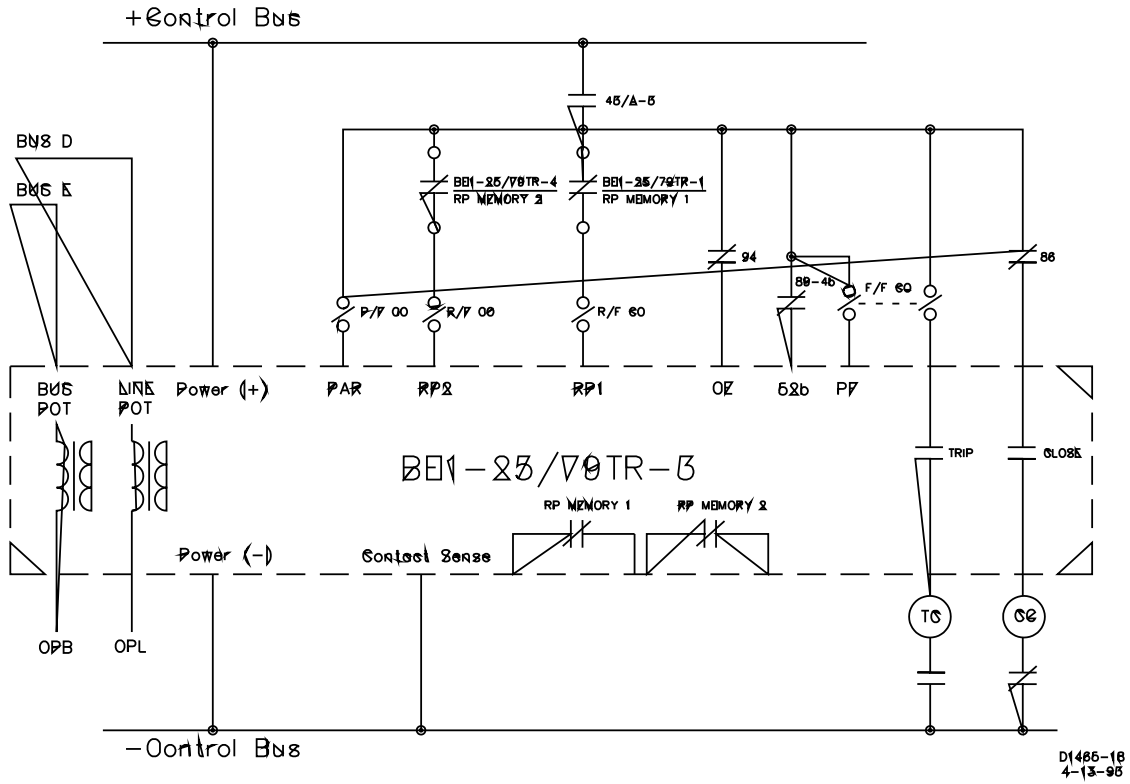

Figure 1-7. Application Example BE1-25/79TR, Relay 3

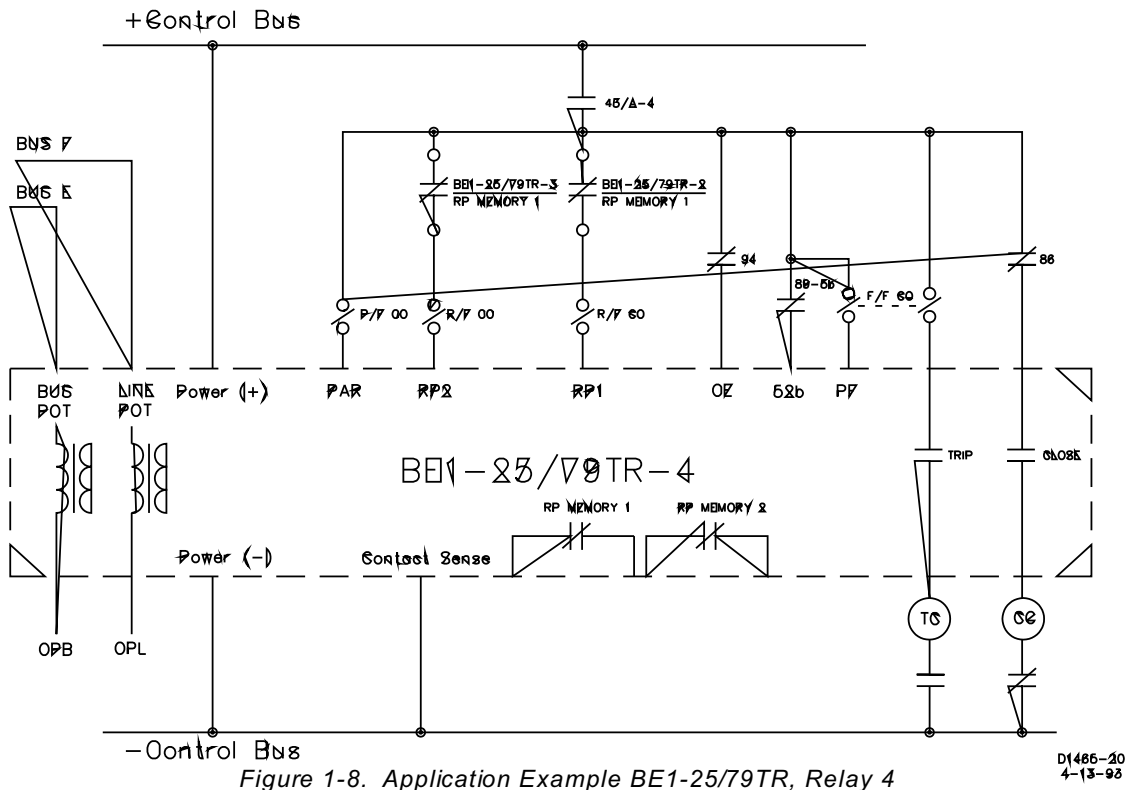

Figure 1-8. Application Example BE1-25/79TR, Relay 4

BE1-25/79TR General Information

Bus D or Transformer T1 Faults and Clears

When a bus D or T1 fault occurs, both power circuit breakers and both motor operated switches trip open. Lines one and two are live and RP1 functions on BE1-25/79TR-1 and -2 relays are enabled through the normally closed contacts of RP memory 1 relays. Both BE1-25/79TR-1 and -2 relays receive the 52b inputs and both BE1-25/79TR-1 and -2 relays provide reclose output pulses to the power circuit breakers. Both breakers close.

BE1-25/79TR-3 and -4 relays for the motor operated switches now have live line and dead bus inputs, RP1 enables, and 52b inputs from the Form B contacts on the motor operated switches. Motor operated switch 89-5 BE1-25/79TR-4 relay also has the parallel input enabled. RP1 timer on the relay for 89-4 times out and the relay provides a reclose pulse for 89-4. 89-4 recloses. When the RP1 timer and sync-check supervision (parallel) allows, the BE1-25/79TR-4 relay for 89-5 parallels and provides the reclose pulse for 89-5. 89-5 successfully recloses. All reset timers in all four BE1-25/79TR relays expire and all four relays reset.

Bus D or Transformer T1 Faults and Fails To Clear

When a bus D or T1 fault occurs, both power circuit breakers and both motor operated switches trip open. Lines one and two are live and RP1 functions on BE1-25/79TR-1 and -2 relays are enabled through the normally closed contacts of RP memory 1 relays. Both BE1-25/79TR-1 and -2 relays receive the 52b inputs and both BE1-25/79TR-1 and -2 relays provide reclose output pulses to the power circuit breakers. Both breakers close. Breaker 52-1 closes into a fault and both breakers open. Lockout timer on BE1-25/79TR-1 relay expires because the breaker is still open after the reclose pulse and the relay drives to lockout. BE1-25/79TR-3 relay 52b input is present but the line potential input is not live. When the master timer expires, the relay drives to lockout. During this time, RP2 timer in BE1-25/79TR-2 is enabled by the input through the RP memory 1, normally closed contacts of BE1-25/79TR-4 relay (motor operated switch 89-5). RP2 timer times out and breaker 52-2 successfully recloses.

RP1 timer in BE1-25/79TR-4 relay for the motor operated switch 89-5 is not enabled because RP memory 1 normally closed contacts are open. RP2 input is enabled through the RP memory 1, normally closed contacts of BE1-25/79TR-3 relay (motor operated switch 89-4). RP2 times out and the relay provides a reclose pulse for 89-5. 89-5 successfully recloses and energizes bus E. Because bus E was dead before the reclose pulse, parallel function was not enabled. Reset timers in BE1-25/79TR-2 and -4 relays expire and both relays reset.

Bus E or Transformer T2 Faults and Fails To Clear

When a bus E or T2 fault occurs, both power circuit breakers and both motor operated switches trip open and all the customers served by the loop station loose power. Lines one and two are live and restore power functions on BE1-25/79TR-1 and -2 relays are enabled. Both BE1-25/79TR relays receive the 52b inputs and both BE1-25/79TR relays provide reclose output pulses to the power circuit breakers. Both breakers close. Customers served by buses D and F have power quickly restored.

Now for bus E. BE1-25/79TR-3 and -4 relays for the motor operated switches now have live line and dead bus inputs, RP1 enables, and 52b inputs from the Form B contacts on the motor operated switches. RP1 timer on the relay for 89-4 times out and the relay provides a reclose pulse for 89-4. 89-4 recloses into a fault on bus E and 89-4 opens. BE1-25/79TR-3 relay for 89-4 drives to lockout because the 52b input is still present and the lockout timer expires. BE1-25/79TR-4 relay for 89-5 has the 52b input present but RP1 can not be enabled because BE1-25/79TR-2, RP memory 1 normally closed contacts are open. RP2 can not be enabled because BE1-25/79TR-3, RP memory 1 normally closed contacts are open. BE1-25/79TR-4 drives to lockout, and only customers on bus E loose service.

BE1-25/79TR General Information

MODEL NUMBERS

Model number variation in BE1-25/79TR Sync-Check Reclosing Relays are specified by the last three digits in the part number. Table 1-1 provides model number, type of relay, mounting style, operating power supply voltage, and communications capability.

Table 1-1. Part Number Cross Reference

Part Number	Description
9278700100	Three-phase, 120 Vac/125 Vdc, Horizontal Mount
9278700101	Three-phase, 48 Vdc, Horizontal Mount
9278700102	Three-phase, 120 Vac/125 Vdc, Vertical Mount
9278700103	Three-phase, 48 Vdc, Vertical Mount
9278700104	Single-phase, 120 Vac/125 Vdc, Horizontal Mount
9278700105	Single-phase, 48 Vdc, Horizontal Mount
9278700106	Single-phase, 120 Vac/125 Vdc, Vertical Mount
9278700107	Single-phase, 48 Vdc, Vertical Mount
9278700200	Three-phase, 120 Vac/125 Vdc, Horizontal Mount Relay (9 2787 00 100) with LPTR Test Box (9 2787 08 100)

SPECIFICATIONS

Power Supply Inputs

(Range)	48 Vdc (24 to 60 Vdc), 125 Vdc (62 to 150 Vdc), or 120 Vac (90 to 132 Vac, 50/60 Hz).
(Burden)	Burden at 60 Hz, 120 Vac is 26 VA, and burden at 125 Vdc is 14 watts. Burden at 50 Hz, 110 Vac is 25 VA.

Voltage and Phase Sensing Inputs

(Range)	Nominally rated at 60 Hz with a range of 55 to 65 Hz and 1 to 135 Vac. Nominally rated at 50 Hz with a range of 45 to 55 Hz and 1 to 120 Vac. Maximum continuous voltage rating is 160% of nominal.
(Burden)	Maximum burden of 1 VA per phase to 125% of nominal voltage.
(Configuration)	Bus and line voltage sensing inputs are isolated. Two inputs are required. One for line potential and one for bus potential.

Phase Angle

(Selection Accuracy)	$\pm 1.0^\circ$ for a nominal input frequency of 50/60 Hz, with an input range of 10 to 135 volts at 25° C.
(Setpoint Accuracy)	$\pm 1.0^\circ$ from a reference measurement at 25° C, at nominal input frequency and levels, over the specified operating range of temperature and input voltages.

Voltage Difference

(Range)	Continuously adjustable over the range of 1 to 135 Vac.
(Accuracy)	$\pm 5.0\%$ or ± 1.0 V whichever is greater.

Line and Bus Voltage Monitor

(Range)	Continuously adjustable over the range of 10 to 135 Vac.
(Accuracy)	$\pm 5.0\%$ or ± 1.0 V whichever is greater.

Contact Sensing Inputs

User-supplied contacts with a minimum rating of 0.05 A at 250 Vdc are required at all contact sensing inputs.

Non-isolated sensing requires an externally applied dc sensing voltage equal to the nominal voltage of the relay power supply input.

Contact recognition is adjustable from 8 to 200 milliseconds in 4 millisecond increments (actual setting times 4 milliseconds).

Line Test 1 (LT1).
 Line Test 2 (LT2).
 Restore Power 1 (RP1).
 Restore Power 2 (RP2).
 Parallel Enable (PAR).
 Power Failure Enable (PF).
 52b = or breaker b seal.
 Counter Enable (CE).

BE1-25/79TR General Information

Contact Sensing Inputs - Continued

High Speed Enable (HSR).
 Block High Speed Reclose (BLK) for 3 phase faults.
 Drive to Lockout (DTL).
 Drive to Reset (DTR).

Serial Port Communications Front and rear panel mounted RS 232-C connectors (9-pin, D subminiature female) for setting, testing, and data collection.

Time Delays Refer to Table 1-2. Timing tolerance for HSR and SYNC timers is $\pm 5\%$ or two cycles, whichever is greater. All other timer tolerances are $\pm 5\%$ or 50 milliseconds, whichever is greater.

Table 1-2. Time Delay Ranges

Number of Delays	Function	Range
2	Line Test (LT1, LT2)	1-999 seconds
2	Restore Power (RP1, RP2)	1-999 seconds
1*	Parallel (PAR)	1-999 seconds
1	Sync-Check (SYNC)	1-999 cycles
1	High Speed Reclose (HSR)	1-999 cycles
1**	Power Fail (PF)	1-99 seconds
2	Reset Time (RST1, RST2)	1-999 seconds
1	Lockout Time (LO)	1-999 seconds
1***	Master Time (MASTER)	1-999 seconds
1	Close Output (CLOSE TD)	1-999 seconds
1	Loss of Potential (LOP TD)	0.01-9.99 seconds

* If the breaker is intended to operate open (parallel disabled) then the relay will go to reset after the master timer times out and RST2 timer expires. The bus and line will both be energized with the PAR input open.

** The power failure function is a tripping function and will not start the master timer.

*** Master timer used is similar in principle to the mechanical repeat cycle (R.C.) timer in which various operations are permitted as the cam rotates. If lockout has not been reached in the preset time allotted, the master timer will time out and determine whether to go to lockout or reset depending upon the state of the breaker and if the bus and line are Live with PAR input disabled.

Outputs All outputs are MOV protected.

(Isolated) Trip, close, sync-check, relay trouble alarm (RT ALM) and memory.

Trip One tripping contact with N.O. configuration.
 Close One closing contact with N.O. configuration.
 Sync The sync-check (PAR) function with voltage measuring circuits has one output relay with a N.O. configuration.
 Memory There are four memory output relays, each with selectable N.O. or N.C. contacts for line test or restore power.

BE1-25/79TR General Information

Outputs - Continued

RT ALM One N.C. output relay that closes for internal microprocessor failure or power supply failure.

PROG There are three N.O. programmable outputs available to indicate voltage monitor conditions, targets and alarms.

(Rating) Output contacts are rated as follows:

Trip Contacts

Make and carry for tripping duty: 30 A per IEEE C37.90
Continuous: 7 A
Break resistive or inductive: 0.3 A at 250 Vdc

Auxiliary and Alarm Contacts

Make and carry: 3 A
Break resistive or inductive: 0.3 A at 250 Vdc

Indicators

(Targets) Eight LED's (red) on the front panel status display. The targets are:

- High Speed Reclose (HSR).
- Power Failure (PF).
- Line Test 1 (LT1).
- Line Test 2 (LT2).
- Restore Power 1 (RP1).
- Restore Power 2 (RP2).
- Parallel (PAR).
- Lockout (LO).

(Timing) Seven timing LED's (green) are used to indicate when a function is timing. The LED's are:

- Line test 1 (LT1).
- Line test 2 (LT2).
- Restore Power 1 (RP1).
- Restore Power 2 (RP2).
- Parallel (PAR).
- Power Failure (PF).
- Lockout (LO).

(Status) One LED (green) and four LED's (yellow) indicate relay status. The green LED (RST) indicates the relay is in reset. The four yellow LED's indicate the bus and line status. They are:

- Dead Bus (DB).
- Live Bus (LB).
- Dead Line (DL).
- Live Line (LL).

BE1-25/79TR General Information

Indicators - Continued

- (Control) Four LED's (yellow) indicate relay control status.
- Trip.
 - Close.
 - 25 (Sync-Check Function).
 - Counter Enable (CE).

Clock Battery

Life Expectancy
10 years (estimated)

Part Number
Basler 26560

Isolation

All terminals have MOV suppressors except the communication, line, and bus terminals. Maximum applied voltage must be no greater than 300 volts where MOV suppressors are used. 1500 Vac at 60 hertz for one minute may be applied across line and bus input terminals, between circuit groups, and between circuit groups and chassis ground in accordance with IEC 255-5 and ANSI/IEEE C37.90-1989 (Dielectric Test).

Surge Withstand Capability

Qualified to ANSI/IEEE C37.90.1-1989 Standard Surge Withstand Capability (SWC) Tests for Protective Relays and Relay Systems.

Fast Transient

All inputs and outputs except for communication ports are qualified to ANSI/IEEE C37.90.1-1989.

Radio Frequency Interference (RFI)

Field tested using a five watt, hand held transceiver operating at random frequencies centered around 144 MHz and 440 MHz, with the antenna allocated six inches from the relay in both horizontal and vertical planes.

Temperature

Operating Range
-40°C (-40°F) to 70°C (158°F).

Storage Range
-65°C (-85°F) to 100°C (212°F).

Impulse Test

Qualified to IEC 255-5.

Weight

13.7 pounds maximum.

Case Size

Horizontal mount. 3.50 inches (2 rack units) high x 19 inches wide.
Vertical mount. 3.50 inches wide x 19 inches high.
Required depth for mounting the relay is adjustable to either 7.37 or 8.37 inches by adjusting mounting flange location.

SECTION 2

CONTROLS AND INDICATORS

Figures 2-1 and 2-2 illustrate the horizontal BE1-25/79TR Sync-Check Reclosing Relay front and rear views.

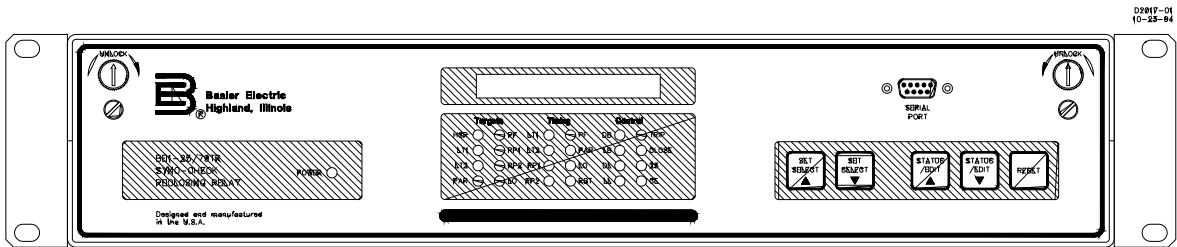

Figure 2-1. BE1-25/79TR Sync-Check Reclosing Relay, Front View

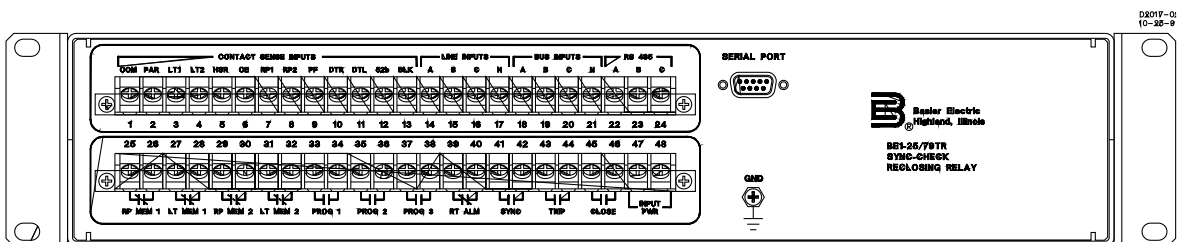

Figure 2-2. BE1-25/79TR Sync-Check Reclosing Relay, Rear View

BE1-25/79TR Controls and Indicators

Table 2-1. BE1-25/79TR, Control Panel, Controls and Indicators (Refer to Figure 2-3).

Locator	Control or Indicator	Function
A	Display	One line, twelve character display to monitor function status and settings.
B	Targets LED's	Eight LED's (red). Seven LED's (HSR, PF, LT1, RP1, LT2, RP2, and PAR indicate associated reclosing output contacts have closed. One LED (LO) indicates relay is in lockout mode.
C	Timing LED's	Eight LED's (green). Seven LED's (LT1, PF, LT2, PAR, RP1, LO, and RP2 indicate associated timer is timing. One LED (RST) indicates relay is in reset mode.
D	Status and Control LED's	Eight LED's (yellow) indicate bus and line status and relay control functions.
E	Settings Select Up	Selects front panel display SETTINGS mode to show all settable parameters and scrolls up through the available settings.
F	Settings Select Down	Selects front panel display SETTINGS mode to show all settable parameters and scrolls down through the available settings.
G	Status/EDIT Up	Scrolls up the status parameters in the STATUS mode and raises the setting displayed on the front panel display while in the SETTINGS mode. Selects yes for specific decision presented on the front panel.
H	Status/EDIT Down	Scrolls down the status parameters in the STATUS mode and lowers the setting displayed on front panel display while in the SETTINGS mode. Selects no for specific decisions presented on the front panel display.
I	Reset Switch	Selects Status mode or Resets Targets display.
J	Port (Connector)	Front panel mounted receptacle for connecting RS 232 communications link.

BE1-25/79TR Controls and Indicators

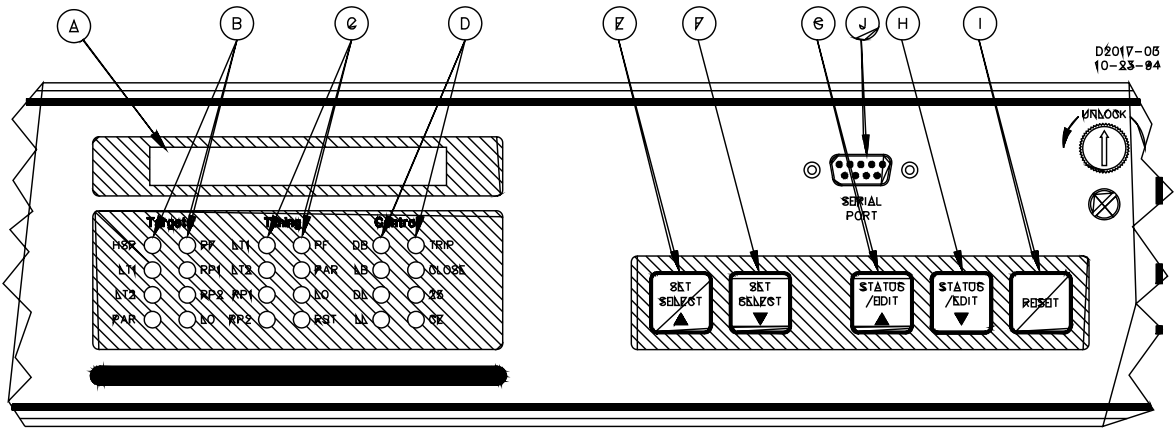
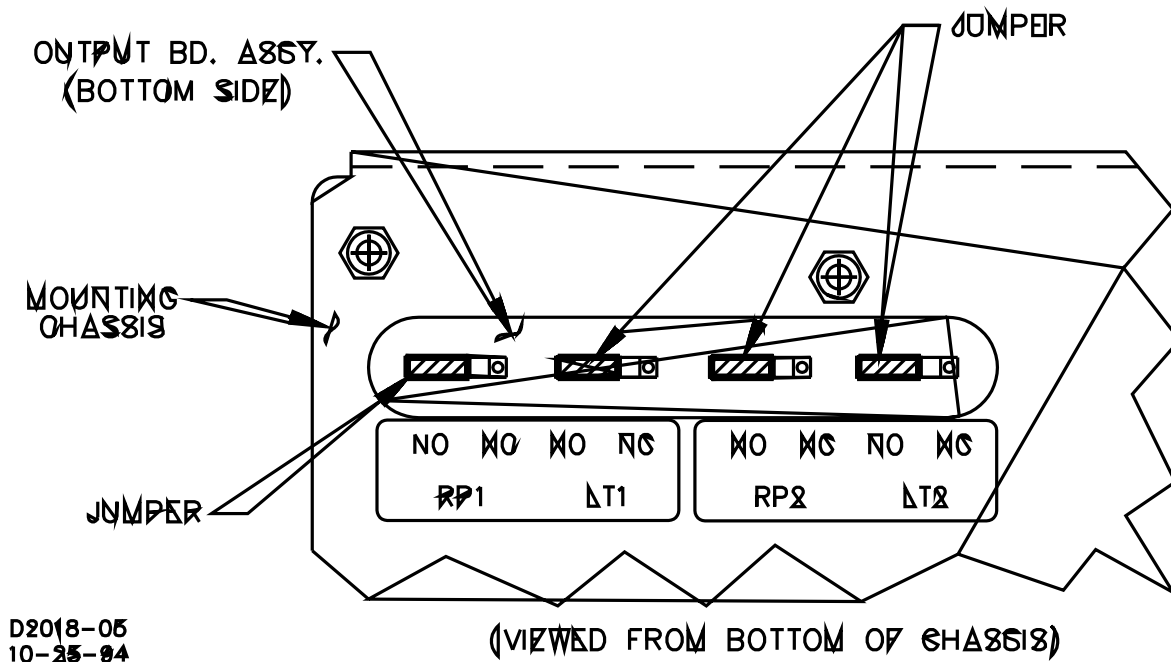

Figure 2-3. Location of Controls and Indicators (Control Panel)

SELECTABLE N.O. OR N.C. OUTPUT CONTACTS

To change the configuration of the RP1, LT1, RP2 and LT1 memory output contacts, turn the two outside locking screws located on the front panel to the unlock position. Grasp the center pull handle and withdraw the electronics from the case. Flip over the electronics to view the bottom of the mounting chassis.

The four memory outputs (RP1, LT1, RP2 and LT2) may be configured to be N.O. (normally open) or N.C. (normally closed) by moving one of the four header jumpers located in the rear left corner (viewed from the bottom) of the relay mounting chassis as shown in Figure 2-4. Reinstallation is reverse of removal.



D2018-05
10-25-94

Figure 2-4. Selectable Output Contacts

BE1-25/79TR Controls and Indicators

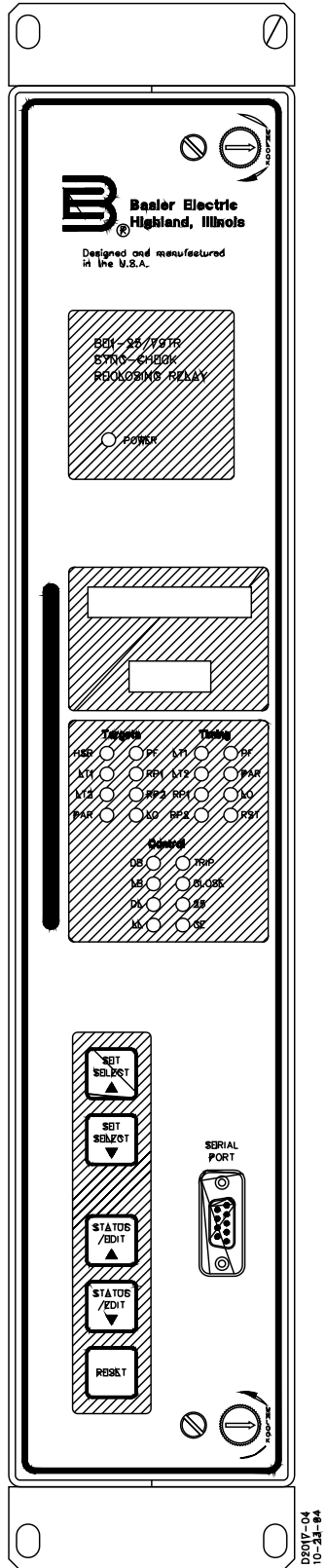

Figure 2-5. Vertical BE1-25/79TR Sync-Check Reclosing Relay, Front View

BE1-25/79TR Controls and Indicators

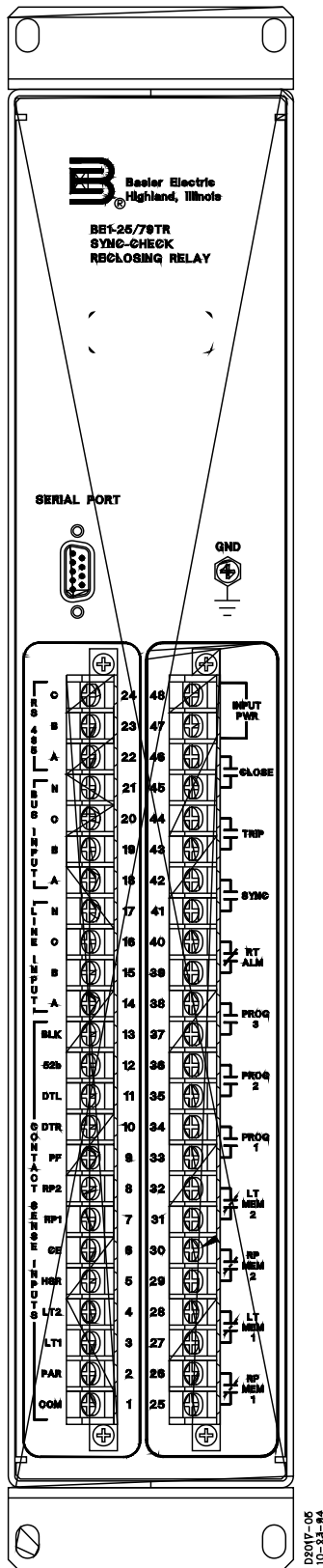
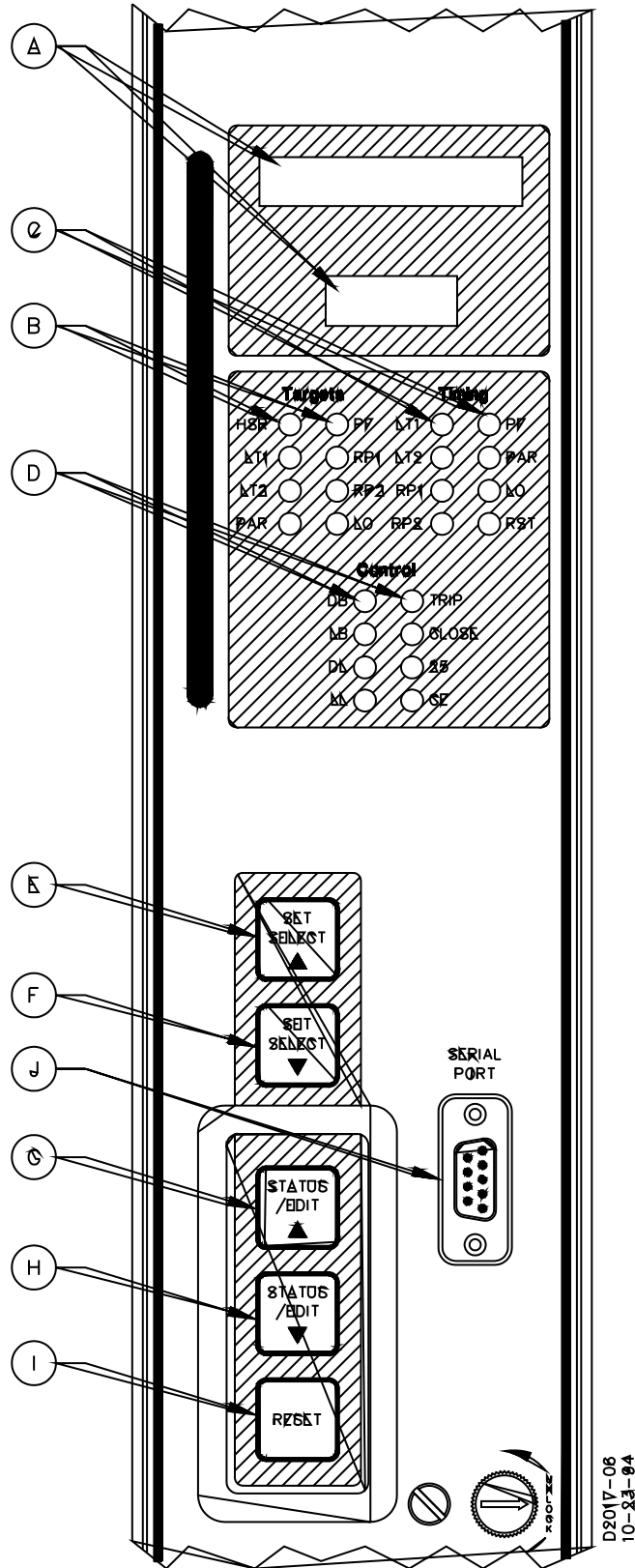

Figure 2-6. Vertical BE1-25/79TR Sync-Check Reclosing Relay, Rear View

BE1-25/79TR Controls and Indicators



D2017-06
10-23-04

Figure 2-7. Front Panel, Vertical Mount Relay

SECTION 3

FUNCTIONAL DESCRIPTION

GENERAL

BE1-25/79TR Sync-Check Reclosing Relays are microprocessor based, solid state devices utilizing digital circuitry to provide breaker control of transmission line systems. Breaker position, bus voltage, and line voltage are monitored to determine proper closing on faulted systems.

BLOCK DIAGRAM ANALYSIS

Refer to Figure 3-1 to follow the BE1-25/79TR block diagram analysis as described in the following paragraphs.

Output/Magnetics Board

Input transformers located on the output/magnetics board isolate the relay from the system and step down the voltages to the levels the internal circuits require. Data, address, and control signals from the input/logic board are processed and used by the output/magnetics board to energize appropriate output relays.

Input/Logic Board

Before any relay output can occur, there must be initiating signals from external contacts. Contact sensing circuitry allows the relay to monitor circuit breaker status (52b) and other input conditions selected by the user. All contact sensing inputs are non-isolated and require an external dc source voltage equal to the input voltage of the relay.

Opto-electronic isolation protects the internal circuitry and changes the contact sensing input voltage to the level required by the microprocessor circuits.

Analog signals from the output/magnetics board are converted to digital signals by an analog to digital convertor (ADC) internal to the on-board microprocessor. The microprocessor uses a four sample per cycle algorithm to calculate voltage magnitudes. Phase angle and slip frequency is measured from analog circuitry that uses zero cross detection methods. All digital input signals from the contact sensing are processed by the on-board microprocessor. Output signals from the input/logic board are sent to the output/magnetics board, the front panel display, and front panel status LED's.

Front and rear panel RS 232-C connectors provide communication ports for communications between a remote computer (rear panel connector) or local computer (front panel connector) and the microprocessor.

Five front panel switches are provided to access different modes of operation when sensed by the microprocessor. A data bus, address bus, and control bus are connected between the input/logic board and output/magnetics board and are used to send data to and from the various modules.

Power Supply

The power supply permits matching the required input voltage to an existing power source. The power supply is a low burden, switching regulator type power supply which delivers a nominal positive and negative 15 Vdc, positive 5 Vdc, and 5 Vdc isolated to internal circuitry.

BE1-25/79TR Functional Description

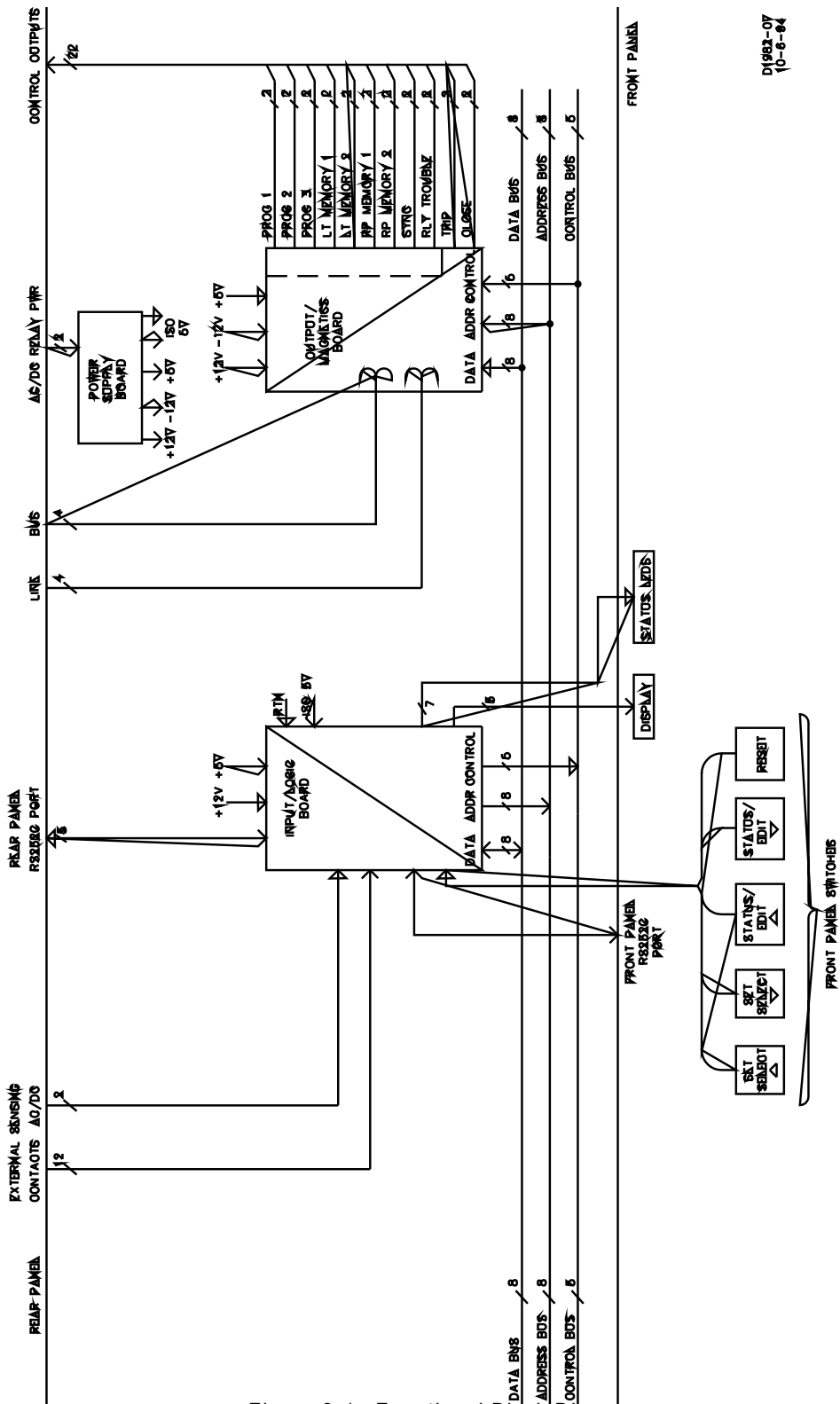

D1982-07
10-6-84

Figure 3-1. Functional Block Diagram

BE1-25/79TR Functional Description

MODES OF OPERATION

BE1-25/79TR Sync-Check Reclosing Relays have two primary modes of operation. They are the status mode and settings mode. These modes are selected by momentarily pushing the front panel Settings Select Up/Settings Select Down or the Reset switches.

Settings Mode

To program a setting or a parameter, select the settings mode by momentarily pushing the Settings Select switches (either up or down). The front panel CE LED will flash to indicate the settings mode has been entered. The CE LED continues to flash while in the settings mode. All reclose and voltage monitor functions are disabled except for some of the active function LED's. The LED's (LL, LB, DL, and DB) indicate existing voltage conditions.

To select a setting or parameter, momentarily push (either up or down) the front panel Settings Select switches. Each time the switch is operated, another parameter is selected as the display scrolls through the available settable parameters. These parameters are as follows.

Front Panel Display	Description	Range
Address	Remote address for future use	1-254
K-BAUD	Communication Baud Rate	0.3, 0.6, 1.2, 2.4, 4.8, 9.6,
MASTER TD	Master Time Delay	1-999 seconds
RST1 TD	Reset 1 Time Delay	1-999 seconds
RST2 TD	Reset 2 Time Delay	1-999 seconds
HSR TD	High Speed Reclose Time Delay	1-999 cycles
LT1 TD	Line Test 1 Time Delay	1-999 seconds
LT2 TD	Line Test 2 Time Delay	1-999 seconds
RP1 TD	Restore Power 1 Time Delay	1-999 seconds
RP2 TD	Restore Power 2 Time Delay	1-999 seconds
PAR TD	Parallel Time Delay	1-999 seconds
SYNC TD	Sync Time Delay	1-999 cycles
PF TD	Power Fail Time Delay	1-99 seconds
LO TD	Lockout Time Delay	1-999 seconds
DEAD BUS	Dead Bus Voltage condition	10-135 volts
DEAD LINE	Dead Line Voltage condition	10-135 volts
LIVE BUS	Live Bus Voltage condition	10-135 volts
LIVE LINE	Live Line Voltage condition	10-135 volts
PHASE W	Phase Window	1-180 degrees
DELTA V	Delta Voltage Window	1-135 volts
FSLIP W	Slip Frequency Window	0.05-1.00 hertz
CLOSE TD	Close Output Time Delay	1-999 seconds
HSR-SYNC	High Speed Reclose with Sync-Check	YES-NO
START52B	Start Master Timer with only 52b	YES-NO
BKR RECG	52b Contact Sensing Input Recognition Time	2-50 (x4 msec)
LOP TD	Loss of potential Time Delay	0-999 (x10 msec)
TST MODE	Test mode Entry	Yes-No
YEAR	Year clock setting	00-99 years
MONTH	Month clock setting	01-12 months
DAY	Day clock setting	01-31 days
HOUR	Hour clock setting	00-23 hours
MINUTE	Minute clock setting	00-59 minutes
SECOND	Second clock setting	00-59 seconds

BE1-25/79TR Functional Description

Front Panel Display	Description	Range
SYS FREQ	Calibration Frequency	60 or 50 set only in Cal Mode
CAL MODE	Calibration Mode Entry	Yes-No

To program a parameter, operate the Settings Select switches until the parameter is displayed. Momentarily operating the Status/EDIT Up or Status/EDIT Down switch steps the display one digit. Holding the Status/EDIT Up or Status/EDIT Down switch will increase the rate of change for the display.

To save the new programmed settings and leave the Settings mode, operate the Reset switch. The display will read SAVE SETUP. If the Status/EDIT Up switch is pushed, all parameter settings that have been changed will be saved. If the Status/EDIT Down is pushed, the changed settings will not be saved.

CAUTION

This product contains one or more nonvolatile memory devices. Nonvolatile memory is used to store information (such as settings) that needs to be preserved when the product is power-cycled or otherwise restarted. Established nonvolatile memory technologies have a physical limit on the number of times they can be erased and written. In this product, the limit is 1,000,000 erase/write cycles. During product application, consideration should be given to communications, logic, and other factors that may cause frequent/repeated writes of settings or other information that is retained by the product. Applications that result in such frequent/repeated writes may reduce the useable product life and result in loss of information and/or product inoperability.

To test the front panel LEDs and the output relays, operate the Settings Select switches until TST MODE NO appears in the display. The test mode is entered by pushing both the Status/EDIT Up and the Reset switches at the same time. When both switches are pushed at the same time, the display changes to TEST MODE. The test routine can be exercised by pushing the Status/EDIT Down switch for each step or holding the switch while the test routine cycles through the LEDs and output relays. To exit the test mode, operate the Reset switch.

Status Mode

Status mode is entered after power-up, when the front panel Reset switch is operated or when the switches are left unchanged for over 1 minute. After entering status mode, the state of the controlled breaker is monitored. RST1 timer times if the breaker is closed. If the breaker stays closed for the duration of RST1 the relay goes to reset with the RST LED on. If the breaker is open with LL, LB, and PAR open (disabled), the RST2 timer times down. If this condition exists for the duration of RST2, the relay goes to reset with the breaker open. If the breaker is open under any other conditions the relay will go to lockout with the LO LED lit.

Operating the Status/EDIT Up or Status/EDIT Down again will step the display through different active parameters. Holding the Status/EDIT Up or Status/EDIT Down will scroll the display through the parameters. The displays are:

- Line voltage level
- Bus voltage level
- Voltage difference level
- Phase angle difference level
- Frequency difference (FSLIP) level
- Timers (enabled timers displaced will decrement)
- Voltage monitor settings (LL, LB, DL, DB, ΔV , Phase Window, and FSLIP Window)
- Date
- Time

BE1-25/79TR Functional Description

The decimal point in the display indicates that these are active parameters in volts, degrees, hertz, or seconds that change depending on system conditions. All voltage monitor settings except the FSLIP window setting do NOT have a decimal point. All other functions displayed in the status mode have a decimal point except the HSR timer (setting is in cycles) and SYNC timer (setting is in cycles). If conditions are below one volt or phase angle difference is less than one degree, UNDR or 0 (zero) is displayed for an under range condition. If the voltages are greater than 150 Vac, OVER is displayed for an over range condition. The default mode for the status display is the MASTER display.

RECLOSING FUNCTIONAL DESCRIPTION

High Speed Reclose

There is one high speed reclose (pilot) function with a time delay of 1 to 999 cycles, and is designated HSR (refer to Figure 5-3). HSR is a momentary input and is latched internally. This function is initiated during carrier tripping when the breaker is closed. For example, a breaker with a three cycle tripping time and the HSR delay time set to 25 cycles will give 22 cycles dead time on the line for deionization of arc gases. This does not take into consideration the breaker closing time. If the breaker has a 12 cycle reclosing time, the reclosing must be initiated with the HSR delay time set to 13 cycles ($25 - 12 = 13$). This function is disabled if a momentary closure of the BLK input is sensed after the momentary HSR input has been sensed.

An adjustable breaker recognition time (BKR RECG) of 8 to 200 milliseconds is available to compensate for breakers with contact bounce and slower recognition. This setting is adjustable from 2 to 50 (8 to 200 milliseconds) where the actual recognition time is the setting multiplied times 4 milliseconds.

An optional HSR-SYNC enable condition may be enabled in the settings mode to allow the sync output to supervise the HSR.

In summary, high speed reclosing has an adjustable delay of 1 to 999 cycles and is affected by two contact sensing inputs (HSR and BLK) and one programmable logic setting (HSR-SYNC).

Parallel (LL-LB Reclose)

There is one reclose with sync-check and voltage monitoring and is designated (PAR). The parallel function is enabled with a cutout switch external to the relay through contact sensing input PAR. If the breaker is intended to operate open, this function would be disabled. The parallel function has a time delay of 1 to 999 seconds. This function is initiated with the PAR input when the breaker is open, and both the bus and line are live. When parallel reclose and sync-check with voltage monitoring is desired, the PAR input and 52b input must be present, bus and line must be live, difference voltage must be less than the delta voltage setting, phase angle difference must be less than the phase window setting, and the slip frequency must be less than the slip frequency window setting. After the parallel time delay has expired, the close output is energized.

Restore Power (LL-DB Reclose)

There are two restore power functions available to energize a dead bus. These functions are designated RP1 and RP2 with either or both used in application. Both restore power timers have a time delay of 1 to 999 seconds. The restore power functions are enabled with cutout switches located external to the relay through contact sensing inputs RP1 and RP2. In order for reclose power output contacts (RP1 or RP2) to close, the appropriate restore power input and 52b input must be present, the line must be live, the bus must be dead, and the restore power timer must expire.

Line Test (DL-LB Reclose)

Two line test functions are available. The functions are designated LT1 and LT2, with either or both used in application. The line test timers have a time delay of 1 to 999 seconds. The line test functions are

BE1-25/79TR Functional Description

enabled with cutout switches located external to the relay through contact sensing inputs LT1 and LT2. In order for line test output contacts (LT1 or LT2) to close, the appropriate line test input and 52b input must be present, the line must be dead, the bus must be live, and the line test timer must expire.

SYNC-CHECK FUNCTION DESCRIPTION

Sync-Check

Sync-check function measures the phase angle between single-phase line and bus voltages. If the measured angle is less than the front panel phase angle window setting, voltage difference is less than the voltage setting, and the time period defined by the sync time delay has expired, then the sync output contact closes and front panel 25 LED lights. The allowable phase angle window is adjustable over the range of 1 to 180 degrees. A phase angle window set greater than 180 degrees disables the phase angle limit. The sync time delay is adjustable over the range of 1 to 999 cycles. The sync-check function is independent of the master timer and can provide independent synchronism reclosing (refer to Figure 3-2). Available parameters (refer to Figure 3-3) are:

Phase Window

- Condition adjustable from 1 to 180 degrees.
- Blocks closing when the phase angle difference between the bus and line are greater than plus or minus this setting.
- Indicated by front panel LED's (LL and LB) when LED's are flashing ON and OFF.

Slip Frequency Window

- Condition adjustable between .05 to 1.00 Hz.
- Blocks closing when frequency difference between bus and line is greater than plus or minus this setting.
- Indicated by front panel LED's (LL and LB) when LED's are flashing ON and OFF.

NOTE: For 3 phase line and 3 phase bus type relays, only phase B is used for phase window and slip frequency window check.

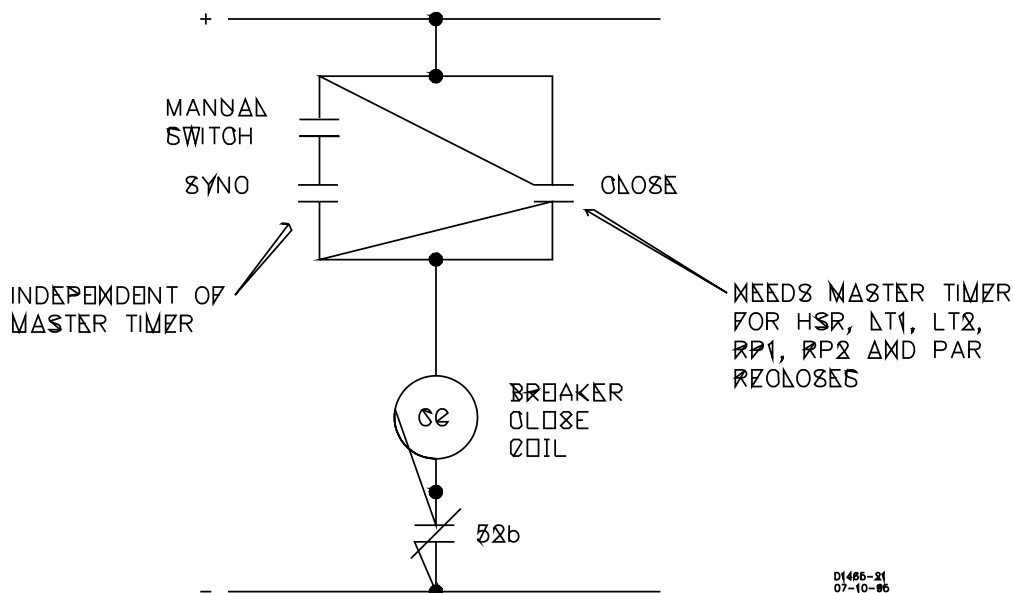

Figure 3-2. Independent Synchronism Reclosing

BE1-25/79TR Functional Description

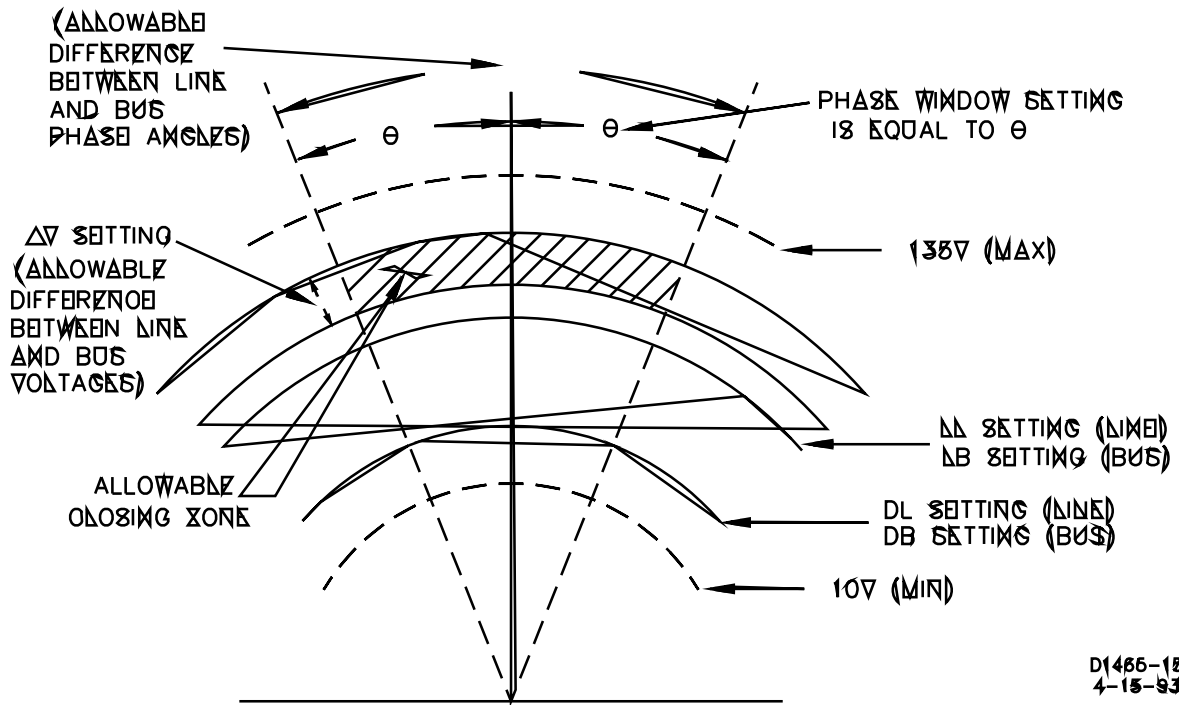

Figure 3-3. Allowable Closing Zone

Voltage Difference

Voltage difference (delta voltage) is typically used to reduce the amount of possible system shock or transients when closing a breaker. Delta voltage compares the magnitude of the voltage between the line and bus against a selected limit. If the delta voltage is less than the set limit, the BE1-25/79TR relay generates an enable signal for the sync-check logic. This function narrows the phasor voltage across the breaker contacts (as compared to a simple sync-check acting alone). Figure 3-2 shows the allowable closing zone obtained by combining voltage difference, phase angle difference, and line and bus live/dead voltage limits. Available parameters are:

Delta (Δ) V

- Condition Adjustable from 1 to 135 Vac.
- Blocks closing when difference between the magnitude of the bus and line potentials is greater than this setting.
- Indicated by front panel LED's (LL and LB) when LED's are flashing ON and OFF.

NOTE: For 3 phase line and 3 phase bus type relays, only phase B is used for voltage difference check.

Voltage Monitor

Voltage monitoring checks the voltage magnitude difference between the two inputs (line and bus). This can be used to prevent the closure of a generator breaker if the voltage difference is too great (even if the phase angle and voltage level monitoring circuits indicate that proper closing conditions are present).

Parameters for determining live or dead conditions are set at the front panel. Line and bus conditions are indicated by front panel LEDs. Available parameters (refer to Figures 3-3 and 3-4) are:

BE1-25/79TR Functional Description

Live Line (LL)

- Condition adjustable from 10 to 135 Vac.
- Enabled when line voltage is greater than setting.
- Indicated by front panel LED when LED is ON.

Dead Line (DL)

- Condition adjustable from 10 to 135 Vac.
- Enabled when line voltage is less than setting.
- Indicated by front panel LED when LED is ON.

Live Bus (LB)

- Condition adjustable from 10 to 135 Vac.
- Enabled when bus voltage is greater than setting.
- Indicated by front panel LED when LED is ON.

Dead Bus (DB)

- Condition adjustable from 10 to 135 Vac.
- Enabled when bus voltage is less than setting.
- Indicated by front panel LED when LED is ON.

NOTE: For 3 phase line and 3 phase bus type relays, all three phase A, B & C must be in the same band for a live or dead condition to exist.

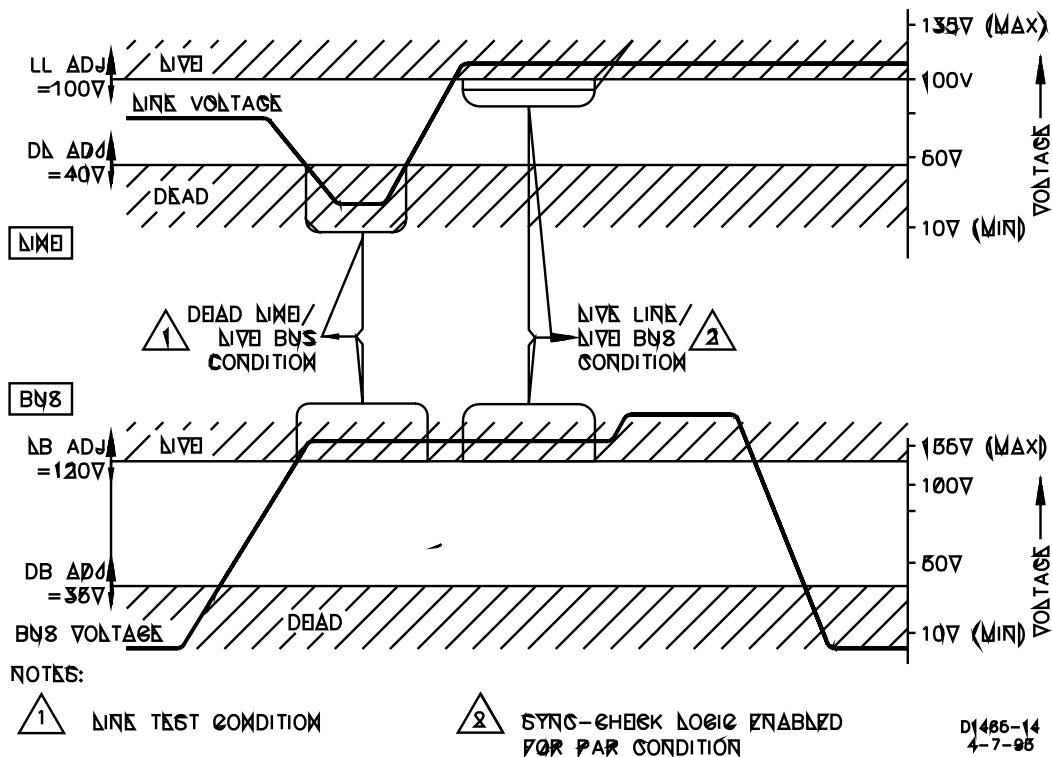

Figure 3-4. Voltage Monitor Parameters

BE1-25/79TR Functional Description

Slip Frequency Difference

For better control of closing angles, differences in the frequency of the bus and line can be limited when the line input is an oncoming generator. The phase angle window must be set to greater than 180 degrees to enable the slip frequency function only (the phase window is disabled). With the phase angle window set to greater than 180 degrees, the phase angle inhibit will be disabled.

TRIPPING FUNCTION, POWER FAIL

There is one power fail (PF) function to trip the breaker in the event of a dead line, dead bus condition. This function is enabled with a cutout switch mounted external to the relay through contact sensing input PF. The power fail timer has a time delay of 1 to 99 seconds. This function is initiated when the PF contact sensing input is enabled (closed), the breaker is closed, and both the line and bus are dead.

CONTROL FUNCTIONS

Counter Enable

One input, counter enable (CE), freezes all timers in their current state when the input is opened regardless of the voltage monitor conditions. The front panel CE LED lights when the CE input is open. When the CE input is closed, the timers resume timing. The timers also freeze when the CE contact sensing input is closed, both bus and line are dead, and the breaker is opened.

Drive to Lockout

One input, drive to lockout (DTL), forces the relay into lockout regardless of voltage conditions and breaker status.

Drive to Reset

The input, drive to reset (DTR), forces the relay into reset mode, the reset LED (RST) lights, and all target LED's and memory outputs are turned off.

TIMING FUNCTIONS

Master Timer

The master timer allows the maximum window of time for a reclosing sequence and has a range of 1 to 999 seconds. When an abnormal condition occurs that requires reclose action (breaker opens and reclose timer is enabled or HSR input is momentarily closed regardless of the state of the breaker), the master timer will start counting down in seconds from its initial setting value along with all of the reclose timers (LT1, LT2, RP1, RP2, and PAR). When the master timer coincides with a time out of one of the reclose timers, a close pulse is initiated if all proper conditions exist for that reclose timer. The close pulse duration (CLOSE TD) is programmable in the settings mode. The target LED for the successful reclose function lights and the memory output is latched if the reclose function is LT1, LT2, RP1, or RP2. The master timer continues counting down after reclose is attempted. Other reclose action may be taken as subsequent reclose time delays time out if their requirements are met. After the master timer times out, the state of the breaker is examined. If the breaker is closed the RST1 timer starts timing down. If the breaker stays closed for the duration of the RST1 time delay, the relay goes to reset. If the breaker is open after the master timer times out the relays goes to lockout except if a Live Line/Live Bus condition exists with the PAR input open (disabled). In this case the RST2 timer will start timing down. If the Live Line/Live Bus with open PAR exists for the duration of RST2, the relay goes to reset with the breaker

BE1-25/79TR Functional Description

open. In all other conditions with the breaker open the relay goes to lockout after the master timer has timed out. At this point the breaker must be closed manually.

Reset Timers

There are two reset timers available, (RST1 and RST2). Both reset timers have a range of 1-999 seconds. If the breaker described in the master timer paragraph remains closed for the duration of RST1, then the RST1 timer will reset and the reset (RST) LED lights. If the breaker described in the master timer paragraph remains open for the duration of RST2 with live line/live bus and PAR input open (disabled), then the RST2 timer will reset and the reset (RST) LED lights. RST1 timer only times during a closed breaker condition after the master timer times out and RST2 timer only times during an open breaker condition with live line/live bus and PAR open after the master timer times out.

Lockout Timer

There is one lockout timer (LO). The lockout timer has a range of 1 to 999 seconds. If the breaker did not close after the duration of the close pulse, the lockout timer will start timing down. The breaker may close by the subsequent timing (such as a second line test or restore power), but if not, and the lockout timer expires, the relay will go to lockout. The lockout (LO) LED will light, indicating an unsuccessful reclose. At this point the breaker must be closed manually.

Reclose Timers

There are five reclose timers (LT1, LT2, RP1, RP2, and PAR). The reclose timers have a range of 1 to 999 seconds. If the master timer is enabled due to conditions described in the master timer paragraph, all five reclose timers will start timing down and the associated timing LED's will light. When a reclose timer times out, the live or dead conditions of the bus and line, status of the breaker, and enable input for that timed out reclose timer will determine if a reclose output is given.

HSR Timer

There is one high speed timer (HSR). The HSR has a range of 1-999 cycles. When a momentary HSR input is received, the HSR timer starts timing down in cycles along with the master timer and reclose timers which count down in seconds. If the breaker is open and no BLK input has been received, a reclose output will be given.

Sync-Check Timer

There is one sync-check timer (SYNC). The sync timer has a range of 1 to 999 cycles. The sync timer is enabled when the breaker is open, the line and bus are both live, the difference voltage is less than the ΔV setting, the phase angle is less than the phase window setting, and the slip frequency is less than the FSslip window setting. The sync timer is completely independent of the reclosing sequence and the master timer.

PF Timer

There is one power fail timer (PF). The power fail timer has a range of 1-99 seconds. If a dead bus and dead line condition exists, the breaker is closed, and PF input is closed (enabled), the PF timer starts counting down and the PF timing LED lights. If, when the PF timer time outs, all of the conditions above are met, the trip output will close to trip the breaker. If the breaker opens, all timing freezes. During this mode, the reset (RST) LED remains lit if the relay was in reset prior to the above conditions.

Close TD Timer

This timer determines the maximum time the close output will stay closed when a reclose attempt is made. This timer is set according to the breaker operate time needed for a successful reclose. The close TD timer has a range of 1 to 999 seconds.

Loss Of Potential Timer

There is one loss of potential timer (LOP). The range is 0.01 to 9.99 seconds. This timer is used to inhibit a line test (LT1 or LT2) or restore power (RP1 or RP2) reclose if the bus or line potential goes dead and

BE1-25/79TR Functional Description

the breaker remains closed (no 52b input) for the duration of the LOP TD. The making of the 52b input prior to the expiration of the LOP timer inhibits the LOP blocking function. A setting of 0 inhibits this function from preventing the reclose.

SELECTION FUNCTIONS

HSR Sync

This selection is used to supervise the high speed reclose (HSR) with the Sync-check function. When set to YES or enabled, this selection will not allow a high speed reclose to occur unless the sync-check conditions are met with SYNC output closed.

Start 52b

This selection allows the master timer to start timing along with all the reclose timers (LT1, LT2, RP1, RP2, and PAR) whenever the breaker opens (52b closes). When set to YES or enabled, the only condition required to start the master timer and reclose timers is the closing of the 52b contact sense input. With this selection, the reclose initiate contact sense inputs (LT1, LT2, RP1, RP2, PAR, or HSR) are not required to start a reclosing sequence.

COMMUNICATIONS

General

Communications interface is provided on the relay front and rear panels. Each communications interface is compatible with standard RS-232 connectors and software. Communications protocol is compatible with readily available modem software that emulate a dumb terminal.

RS 232-C Format

Configure external terminals or computers with the following settings or parameters:

- Baud rate 300,600,1200,2400, 4800, 9600, or 19200
- Data bits Eight
- Stop bits Two
- Parity None
- Terminal emulation DECVT-100 compatible
- Software flow control (XON, XOFF) ON
- Carriage return (CR) translation . Carriage return only.
- Line feed (LF) OFF
- Line wrap OFF

Serial Port Connections and Configurations

Front and rear serial communication ports are RS 232-C female DB-9 connectors used to communicate with data terminal equipment (i.e. - computer or terminal) or data communications equipment (i.e. - modem). Because communication intelligence resides inside the relay, no special commands or software is needed to retrieve and transmit data other than a few keystrokes from the external terminal or computer. Off-the-shelf modem software such as *Procomm V2.4* can be used to communicate with the relay.

Computers with Windows can use Windows Terminal application to communicate with the relay. To setup the Terminal application, choose terminal in the accessories group. Pull down the Settings menu and select Terminal Emulation (refer to Figure 3-5). After you have chosen Terminal Emulation, a dialog box similar to Figure 3-6 should appear. Select DEC VT-100 and OK the selection.

Pull down the Settings menu again and select Terminal Preferences and a dialog box similar to Figure 3-7 should appear. Next specify the communications settings. From the Settings menu, choose Communications and a dialog box similar to Figure 3-8 should appear. Choose settings as shown.

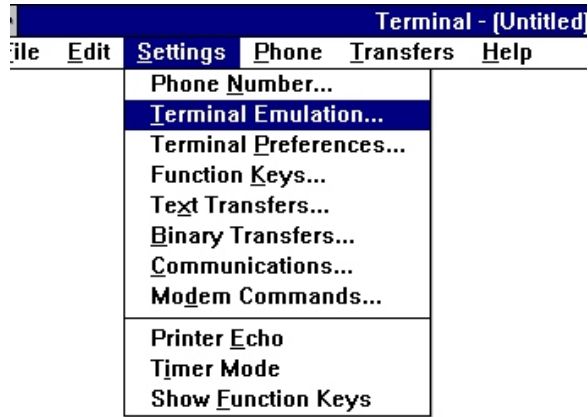

Figure 3-5. Settings Menu

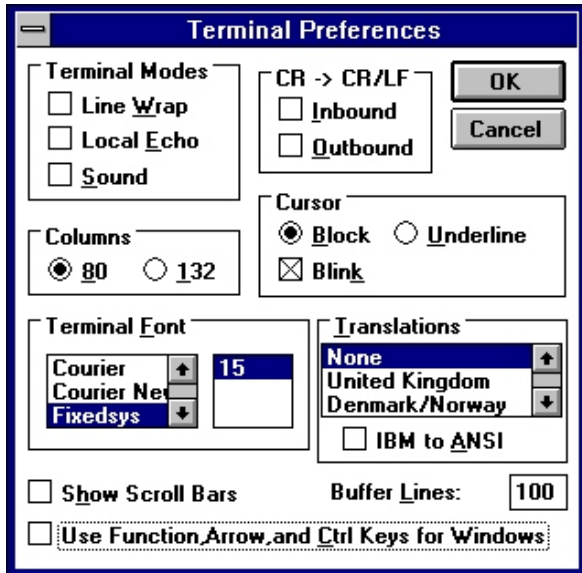
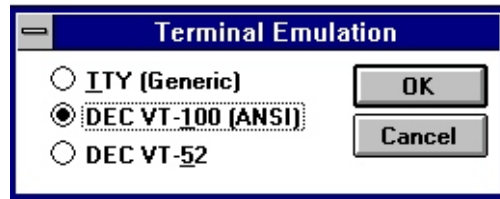

Figure 3-7

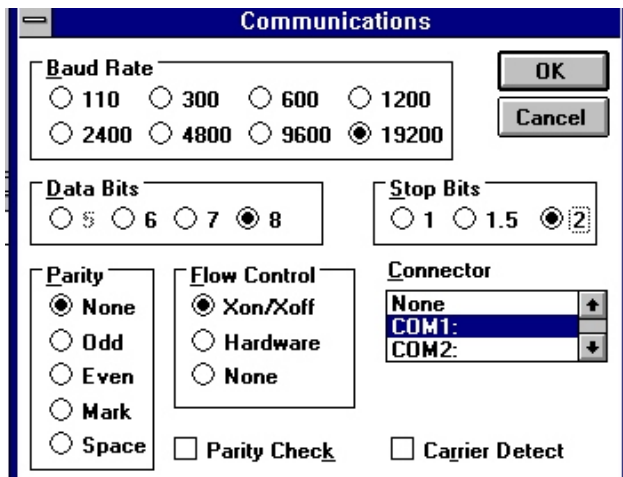

Figure 3-8. Communications Settings

To initially prepare the relay for communications, set the front panel baud rate using front panel switches in the settings mode. The K-BAUD setting must be selected by using the settings select switch. Once the K-BAUD setting is selected, the desired baud rate is set using the settings raise/lower switch. The rear port baud rate can only be set from the review/edit settings screen using an external terminal or computer. The same baud rate selected for the relay must also be selected on the external terminal or computer.

BE1-25/79TR Functional Description

Serial Communication

Front and rear serial port communication cannot take place at the same time. Priority is given to the front panel port.

If communication is in progress but no keys on the terminal are typed for five minutes, communication is stopped. A fixed timeout of five minutes in the relay software allows switching devices such as the SEL PRTU or RFL 9660 switch to regain communication at the rear port in case the front port is left unattended or connected.

If rear port communication is taking place when the front port is connected, there are two ways to stop rear port communication and allow front port communication.

- 1.) Keystroke ESC (to enter the main menu) must be typed on the front (local) terminal/computer.
- 2.) Keystroke Q (to exit the main menu) must be typed on the rear (remote) terminal/computer.

An XON (Ctrl-Q) may be needed at the front port to start communications if the rear port had recently received an XOFF (Ctrl-S). To allow rear port communication to continue, the front port must exit from the main menu with the Q keystroke or allow the five minute timeout to stop communication.

Use built-in functions in the modem software to print screen data or capture data to a file. No special commands are needed to retrieve data other than a few keystrokes to select the desired screen. Each screen is displayed by transmitting a series of information strings. The information can be raw data, such as the text that comprise column titles or escape sequences. Escape sequences are interpreted by the VT-100 compatible terminal to perform various functions such as clearing the screen, positioning the cursor, set screen attributes, etc. Lines on a screen can be displayed in any order. In fact, screen information is displayed in a totally random fashion (bottom lines can be transmitted prior to top lines, right most data can be displayed prior to left most data). XON (Ctrl-Q) and XOFF (Ctrl-S) can freeze data on the remote terminal or computer screen as the screen is being updated.

Starting Communication

With a computer or terminal connected to the relay and the modem software operating, begin communication by pressing the ESC key (refer to Figure 3-9 for screen flow diagram and keystroke sequence). Screen 1, MAIN MENU, appears on the monitor when communication begins. From this point on, the communication is menu driven. Select the desired main activity (screen number) to continue or Q to exit. Movement is made within the screens with standard arrow keys → ← ↑ ↓. To refresh the screen with the latest data, use **Ctrl-R**.

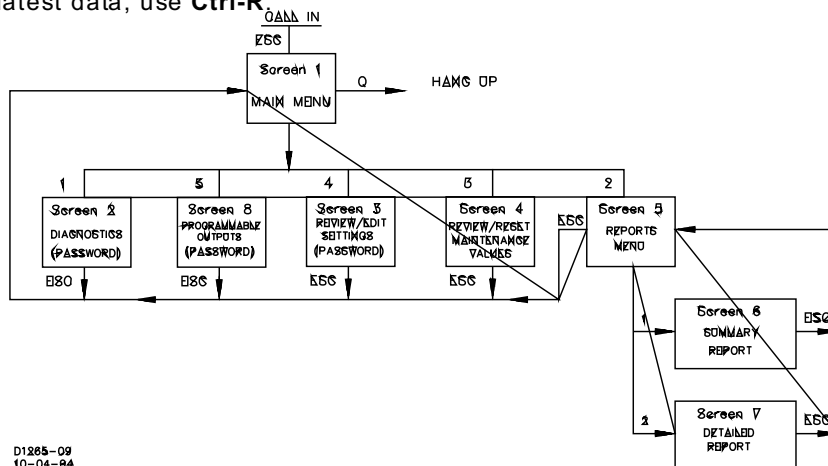

Figure 3-9. Communication Terminal Screens Flow Diagram

BE1-25/79TR Functional Description

Main Menu and Activities

There is one main menu and four main activities: diagnostics, review/edit settings, review/reset maintenance values, and reports menu. Diagnostics and review/edit settings activities are password protected to prevent accidental changes to the operating parameters.

Main Menu (Figure 3-10)

This main menu screen allows you to select the desired activity. The choices are:

1. DIAGNOSTICS - Observe the status of the power supply, A/D converter, RAM, ROM, EEPROM CAL numbers, SYS FREQ setting, LINE voltage magnitude, BUS voltage magnitude, voltage difference, phase angle difference and frequency slip difference. This selection requires the DIAGNOSTIC PASSWORD for entrance to the screen.

2. REPORTS MENU - Two types of report forms are available from this menu. A detailed report form or a summary report form. Reports are available for each record stored in the relay. Each record includes one or more events.

3. RESET MAINTENANCE VALUES - This screen provides a means for the user maintenance personnel to reset the number of breaker operations associated with breaker maintenance and the events stored for record report storage. Passwords, Line#, Station#, Breaker# and Relay ID are also defined in this screen for report generating and entry/exit into other screens.

4. REVIEW / EDIT SETTINGS - Define, review, or change relay operational settings. This selection requires the EDIT SETTINGS PASSWORD for entrance to the screen.

5. PROGRAMMABLE OUTPUTS - Define conditions for three programmable outputs. This selection requires the EDIT SETTINGS PASSWORD for entrance to the screen.

Q.EXIT - This will cause access to the relay to be terminated.

```
RELAY ID: XXXXXXXXXXXXXXXXXXXXXXXX
DATE mm/dd/yy                TIME hh:mm:ss
BASLER ELECTRIC BE1-25/79TR TRANSMISSION RECLOSING RELAY
SELECT ACTIVITY:
1  DIAGNOSTICS
2  REPORTS MENU
3  REVIEW / RESET MAINTENANCE VALUES
4  REVIEW / EDIT SETTINGS
5  PROGRAMMABLE OUTPUTS
Q  EXIT
PRESS KEY FOR DESIRED ACTION

MODEL # xxxxxxxx xxxxxxxxxxxx    SERIAL # xxxxxxxxxxxx
VER  xx.xx-xx.xx mm/dd/yy
```

Figure 3-10. Main Menu Screen

BE1-25/79TR Functional Description

RELAY ID is a special 24 character label entered in the review/reset maintenance screen to identify this relay from other devices. DATE and TIME are the current date and time as reported from the relay. The MODEL # is a set of characters/numbers that identifies the options for this model of relay. The SERIAL # is the serial number of the relay. The VER is the version control number used to identify hardware and software version of the relay.

Diagnostics (Figures 3-11 & 3-12)

This activity screen provides a view of diagnostic elements within the relay to determine if all internal parameters are operating correctly.

The DIAGNOSTIC password is required (defined in the review/reset maintenance screen) to enter this screen.

RELAY ID is a special 24 character label entered in the review / reset maintenance screen to identify this relay from other devices. DATE and TIME are the current date and time as reported from the relay.

The internal parameters are checked at power up and during normal operation. If no problems are found then OK is displayed after each parameter. If a problem is found, then ERROR is displayed after that parameter and the relay should be taken out of service until the problem is corrected. The **SYS FREQ** parameter indicates whether the unit is calibrated for 50 or 60 hertz. The lower five parameters are real time values displayed on the front panel of the relay. To update this screen after initial entry and to see the present values, press the keystroke **CNTL-R**.

RELAY ID: XXXXXXXXXXXXXXXXXXXXXXXXX	DATE mm/dd/yy	TIME hh:mm:ss
DIAGNOSTICS		
PARAMETER	STATUS	
RAM	OK / ERROR	
ROM	OK / ERROR	
A/D CONVERTER	OK / ERROR	
EEPROM	OK / ERROR	
PT CAL NUMBERS	OK / ERROR	
POWER SUPPLY	OK / ERROR	
SYS FREQ	60/50	
LINE V	xxx.x	
BUS V	xxx.x	
DIFF V	xxx.x	
P ANGLE	xxx.x	
F SLIP	xx.xx	
PRESS 'ESC' TO RETURN TO MAIN MENU		

Figure 3-11. Diagnostics Screen - Single Phase

BE1-25/79TR Functional Description

RELAY ID: XXXXXXXXXXXXXXXXXXXXXXXXX		
DATE mm/dd/yy		TIME hh:mm:ss
DIAGNOSTICS		
PARAMETER	STATUS	
RAM	OK / ERROR	
ROM	OK / ERROR	
A/D CONVERTER	OK / ERROR	
EEPROM	OK / ERROR	
PT CAL NUMBERS	OK / ERROR	
POWER SUPPLY	OK / ERROR	
SYS FREQ	60/50	
LINE V (a b c)	xxx.x	xxx.x xxx.x
BUS V (a b c)	xxx.x	xxx.x xxx.x
DIFF V (b)	xxx.x	
P ANGLE (b)	xxx.x	
F SLIP (b)	xx.xx	
PRESS 'ESC' TO RETURN TO MAIN MENU		

Figure 3-12. Diagnostics Screen - Three Phase

BE1-25/79TR Functional Description

Review/Edit Settings (Figure 3-13)

This activity screen provides a review and edit of the front panel settings from a remote terminal.

The EDIT SETTINGS password is required (defined in the review/reset maintenance screen) to enter this screen.

RELAY ID is a special 24 character label entered in the review/reset maintenance screen to identify this relay from other devices. DATE and TIME are the current date and time as reported from the relay. The settings on this screen are the same settings that can be set from the front panel of the relay except for the BAUD RATE - REAR setting which is only settable from this screen.

After making the setting change, the user must press ESC and answer DO YOU WANT TO SAVE NEW SETTINGS: (Y/N)? with Y before the selection is actually saved and set in the settings table.

RELAY ID: XXXXXXXXXXXXXXXXXXXXXXXXX							
DATE mm/dd/yy				TIME hh:mm:ss			
REVIEW / EDIT SETTINGS							
FUNCTION	EXIST	NEW		FUNCTION	EXIST	NEW	
MASTER TD	100	nnn	SEC	PHASE W	20	nnn	DEGREES
RST 1 TD	10	nnn	SEC	DELTA V	1.00	n.nn	VOLTS
RST 2 TD	15	nnn	SEC	F SLIP W	00.25	nn.nn	HERTZ
HSR TD	50	nnn	CYCLES	CLOSE TD	2	nn	SEC
LT1 TD	25	nnn	SEC	HSR-SYNC	0	n	0=N,1=Y
LT2 TD	30	nnn	SEC	BKR RECG	4	nn	x4 MSEC
RP1 TD	35	nnn	SEC	LOP TD	100	xxx	x10 MSEC
RP2 TD	40	nnn	SEC	YEAR	93	nn	
PAR TD	60	nnn	SEC	MONTH	2	nn	
SYNC TD	10	nnn	CYCLES	DAY	17	nn	
PF TD	5	nnn	SEC	HOUR	45	nn	
LO TD	5	nnn	SEC	MINUTE	30	nn	
DEAD BUS	20	nnn	VOLTS	SECOND	25	nn	
DEAD LINE	20	nnn	VOLTS	START 52B	0	n	0=N, 1=Y
LIVE BUS	70	nnn	VOLTS	BAUD RATE	19200	nnnnn	FRONT
LIVE LINE	70	nnn	VOLTS	BAUD RATE	19200	nnnnn	REAR

LOP TD RANGE = MIN 0 MAX 999 X 10 MSEC 0 = INHIBIT
 PRESS 'ESC' TO RETURN TO MAIN MENU

Figure 3-13. Review/Edit Settings Screen

BE1-25/79TR Functional Description

Review/Reset Maintenance Values (Figure 3-14)

This activity screen provides a review and reset of the number of breaker operations that affect breaker maintenance and events/records needed for report generation.

RELAY ID is a special 24 character label entered in this screen to identify this relay from other devices. DATE and TIME are the current date and time as reported from the relay.

RESET EVENTS marks a special record that displays RESET BY USER in the summary report and displays the system conditions on the detailed report screen that existed when the events were reset. All events are cleared and the record counter is set equal to 01.

RESET BKR OP COUNT clears the counter for the number of breaker operations that occur each time the breaker closes. The present breaker operation count is displayed after PRESENT BKR OP COUNT =. No alarm setting is available for a particular number of these counts. This parameter is only to be used for monitoring and scheduling breaker maintenance.

EDIT SETTINGS PASSWORD and DIAGNOSTICS PASSWORD are 8 character or less passwords required to enter the REVIEW/EDIT SETTINGS screen, PROGRAMMABLE OUTPUTS screen, and DIAGNOSTICS screen. The EDIT SETTINGS PASSWORD is used for both the REVIEW/EDIT SETTINGS screen and PROGRAMMABLE OUTPUTS screen. These passwords can only be changed after the existing password has been typed and return (enter) has been pressed. After the correct password has been typed, <enter new password> will be displayed under the EXIST column. If an incorrect password is typed, then <rejected> will be displayed under the EXIST column. If the correct password is typed then a new password may be entered under the NEW column.

RELAY ID: XXXXXXXXXXXXXXXXXXXXXXXX		
DATE mm/dd/yy		TIME hh:mm:ss
REVIEW / RESET MAINTENANCE VALUES		
RESET EVENTS	y/n	
RESET BKR OP COUNT	y/n	
PRESENT BKR OP COUNT =	xxxxx	
	EXIST	NEW
EDIT SETTINGS PASSWORD	xxxxxxx	nnnnnnnn
DIAGNOSTICS PASSWORD	xxxxxxx	nnnnnnnn
STATION NAME	XXXXXXXXXXXXXXXXXXXX	nnnnnnnnnnnnnnnnnnnnnn
LINE NAME	XXXXXXXXXXXXXXXXXXXX	nnnnnnnnnnnnnnnnnnnnnn
BREAKER #	xxxxx	nnnnn
RELAY ID		nnnnnnnnnnnnnnnnnnnnnn
PRESS 'ESC' TO RETURN TO MAIN MENU		

Figure 3-14. Review/Reset Maintenance Values Screen

BE1-25/79TR Functional Description

After a new password is typed and return (enter) is pressed, <reenter password> will be displayed under the EXIST column. The new password must be typed in a second time for verification. If the new password typed in the second time matches the first time, then <new password accepted> will be displayed under the EXIST column. Permissible password characters are 0 to 9, A to Z, and underscore (_). A blank or return may be used to get around using the password by typing return (enter) when a new password is entered. This results in displaying < null > under the NEW column.

NOTE

The factory setting password for both the diagnostic screen and review/edit settings screen is **TR**.

NOTE

Existing passwords may be viewed without typing in the existing password by applying power to the relay with the STATUS RESET front panel switch held down until STATUS MODE is seen on the front panel display. Doing this allows the passwords to be seen and edited the first time the REVIEW/RESET MAINTENANCE VALUES screen is entered. The next time the REVIEW/RESET MAINTENANCE VALUES screen is entered the passwords are not displayed.

STATION NAME and LINE NAME are labels (20 characters or less) entered in this screen to be displayed during report generation from the summary report or detailed report. Permissible non/password characters are 0 to 9, A to Z, underscore (_), period (.), backward slash (\), forward slash (/), and dash (-).

BREAKER # is a five digit number entered in this screen to be displayed on the report screens.

The RELAY ID is a label (24 characters or less) entered in this screen and displayed on other screens. It is intended to be a unique identifier for the relay. There is no EXIST setting for the RELAY ID because the RELAY ID at the top of the screen will act as the EXIST setting when RELAY ID is edited. Permissible non/password characters are 0 to 9, A to Z, underscore (_), period (.), backward slash (\), forward slash (/), and dash (-).

After making the reset selection, the user must press ESC and answer DO YOU WANT TO SAVE NEW SETTINGS: (Y/N)? with Y before the selection is actually reset or the new labels are stored to the relay.

BE1-25/79TR Functional Description

Reports Menu (Figure 3-15)

This activity screen selects one of two possible reports that will display the stored events in the relay.

RELAY ID is a special 24 character label entered in the review/reset maintenance settings screen to identify this relay from other devices. DATE and TIME are the current date and time as reported from the relay.

The SUMMARY REPORT displays a screen that shows the input type name, input direction, and time associated for each event for a selected record.

The DETAILED REPORT displays a screen that shows the system status, input conditions, output conditions and timer status for each event for a selected record.

RELAY ID: XXXXXXXXXXXXXXXXXXXXXXXXX	
DATE mm/dd/yy	TIME hh:mm:ss
REPORTS MENU	
SELECT ACTIVITY	
1	SUMMARY REPORT
2	DETAILED REPORT
PRESS KEY FOR DESIRED ACTION	
PRESS 'ESC' TO RETURN TO MAIN MENU	

Figure 3-15. Reports Menu ScreenSummary Report (Figure 3-16)

BE1-25/79TR Functional Description

This activity screen displays a summary report of each record beginning with the most recent record.

Records are numbered 1 to 99. When record #99 occurs the next following record will be record #1.

Each record contains a number of events. An event is stored every time that a control input changes, a system change occurs, an output change occurs, or a mode changes. A record starts when an event is stored and the record continues gathering events until the relay reaches RESET MODE or LOCKOUT MODE.

The EVENT NAME will be one of the following:

Control Inputs	System Change	Output Change	Mode Change
52B	LIVE LINE	CLOSE	RESET MODE
BLOCK HIGH SPEED	DEAD LINE	TRIP	LOCKOUT MODE
DRIVE TO LOCKOUT	LINE - - -	OUTPUT SYNC	TRIGGER
DRIVE TO RESET	LIVE BUS	LT1 MEMORY	RESET BY USER
POWER FAILURE	DEAD BUS	LT2 MEMORY	LOSS OF POTENTIAL
LINE TEST 1	BUS - - -	RP1 MEMORY	
LINE TEST 2	SYSTEM SYNC	RP2 MEMORY	
RESTORE POWER 1	SYSTEM UNSYNC	RELAY TROUBLE	
RESTORE POWER 2			
PARALLEL			
H I G H S P E E D			
RECLOSE			
CONTROL ENABLE			

RESET MODE and LOCKOUT MODE are represented on the front panel of the relay when the Reset LED or Lockout LED are lit. TRIGGER occurs when T is typed in this screen or the DETAILED REPORT screen. LOSS OF POTENTIAL occurs when either the bus or line goes dead while the breaker is closed for the duration of the LOP TD. RESET BY USER occurs when the RESET EVENT parameter is set in the REVIEW/RESET MAINTENANCE VALUES screen. LOSS OF POTENTIAL occurs when either the bus or line goes dead while the breaker is closed for the duration of the LOP TD.

DIRECTION (used only when a control input changes) indicates the changed input state with a 0 (normal state) or 1 (off normal state).

A maximum of 100 events can be stored in the relay. The total number of records depends on the number of events that each record contains. For example, if each record holds 10 events then only the last 10 records are stored.

Keystrokes **P** (previous record), **N** (next record), or **G XX** (go to record number XX) selects the desired record number.

Keystroke **T** is used to trigger an event to give a snapshot of the present conditions.

Cursor arrow keystroke up-arrow (↑) scrolls the events up one event or down-arrow (↓) scrolls the events down one event. When more than seven events are present in one record, right-arrow (→) scrolls the events down seven events or left-arrow (←) scrolls the events up seven events.

DATE and TIME are displayed at the top of the screen to indicate when the last (most recent) event in the record occurred.

The HH:MM:SS.SH under the TIME column indicate the hours, minutes, seconds and second hundredths when the event occurred.

The screen is automatically updated when a new event occurs. XON (Ctrl-Q) can be used to freeze the screen and XOFF (Ctrl-S) will restart the screen update. Ctrl-R can be used to refresh the screen with the latest data.

BE1-25/79TR Functional Description

BE1-25/79TR SUMMARY REPORT		
DATE: XX/XX/XX		TIME: XX:XX:XX
STATION: XXXXXXXXXXXXXXXXXXXXX		RECORD NUMBER: XX
LINE: XXXXXXXXXXXXXXXXXXXXX		RELAY SERIAL # XXXXXXXXXX
BREAKER # XXXXX		
TIME	DIRECTION	EVENT NAME
HH:MM:SS.SH		RESET MODE
HH:MM:SS.SH	0	52 B
HH:MM:SS.SH		TRIGGER
HH:MM:SS.SH	0	LINE TEST 1
HH:MM:SS.SH	1	LINE TEST 1
HH:MM:SS.SH		LOSS OF POTENTIAL
PRESS 'P' FOR PREVIOUS OR 'N' FOR NEXT RECORD AND ARROW KEYS TO SCROLL		
PRESS 'T' TO TRIGGER AN EVENT AND 'G' FOLLOWED WITH xx TO GO TO A RECORD		
PRESS 'ESC' TO RETURN TO REPORTS MENU		

Figure 3-16. Summary Report Screen

Detailed Report (Figure 3-17)

This activity screen provides a detailed report of each record beginning with the most recent record. Records are numbered 1 to 99. When record #99 occurs the next following record will be record #1. Each record contains a number of events. An event is stored every time that a control input changes, a system change occurs, an output change occurs, or a mode changes. A record starts when an event is stored and the record continues gathering events until the relay reaches RESET MODE or LOCKOUT MODE. RESET MODE and LOCKOUT MODE are represented on the relay front panel when the Reset LED or Lockout LED are lit. TRIGGER occurs when T is typed in this screen or in the SUMMARY REPORT screen to give the status of the inputs and system parameters at a desired time.

A maximum of 100 events can be stored in the relay. The total number of records depends on the number of events that each record contains. For example, if each record holds 10 events then only the last 10 records are stored.

A 1 indicates that the system parameter (BUS, LINE, SYNC), inputs (52b, DTL, DTR, BLK, HSR, LT1, LT2, RP1, RP2, PAR, PF, CE), outputs (CLOSE, TRIP, SYNC, LT1 MEMORY, LT2 MEMORY, RP1 MEMORY, RP2 MEMORY, TRBLE) or timers (LT1, LT2, RP1, RP2, PAR, PF, LO, RST1, RST2, SYNC) are in an off normal state (active). A 0 indicates that the system parameter, input, output, or timer is in

BE1-25/79TR Functional Description

a normal state (inactive). A - (dash) indicates that the system parameter (BUS or LINE) is in between dead and live. It is not dead and not live.

Under SYSTEM heading in Figure 3-17, BUS, LINE, and SYNC in the most recent event (top line) have a 0 indicating that the bus and line are live (hot). Therefore, conditions for synchronization are present where the voltage difference is less than the DIFF V setting, the phase difference is less than the P ANGLE setting, and the slip frequency is less than the F SLIP setting. Any other conditions will result in an off normal state and will be indicated with a 1 in the SYSTEM SYNC column.

Under INPUTS in Figure 3-17, an input with a 0 indicates the contact sensing input is open. If the input is a 1, it indicates that the contact sensing input is closed.

Under OUTPUTS in Figure 3-17, an output with a 0 indicates that the output relay is not energized. If the output is a 1, it indicates that the output relay is energized. Numbers 1, 2, 3, and 4 are used under the OUTPUTS, MEM column to distinguish between the four memory outputs. 1 = LT1 memory, 2 = LT2 memory, 3 = RP1 memory, and 4 = RP2 memory. The most recent change in the OUTPUTS, MEM column will be displayed.

Under TIMERS in Figure 3-16, a timer with a 0 indicates that the timer is not running. If the timer is a 1, it indicates that the timer is enabled and running.

Keystrokes **P** (previous record), **N** (next record), or **G XX** (go to record number XX) selects the desired record number.

Keystroke **T** is used to trigger an event to give a snapshot of the present conditions.

Cursor arrow keystroke up-arrow (↑) scrolls the events up one event or down-arrow (↓) scrolls the events down one event. When more than seven events are present in one record, right-arrow (→) scrolls the events down seven events or left-arrow (←) scrolls the events up seven events.

DATE and TIME are displayed at the top of the screen to indicate when the most recent event in the record occurred.

The HH:MM:SS.SH under the TIME column indicate the hours, minutes, seconds and second hundredths when the event occurred.

The screen is automatically updated when a new event occurs. XON (Ctrl-Q) can be used to freeze the screen and XOFF (Ctrl-S) will restart the screen update. Ctrl-R can be used to refresh the screen with the latest data.

BE1-25/79TR Functional Description

BE1-25/79TR DETAILED REPORT																																						
DATE: XX/XX/XX												TIME: XX:XX:XX																										
STATION: XXXXXXXXXXXXXXXXXXXXX												RECORD NUMBER: XX																										
LINE: XXXXXXXXXXXXXXXXXXXXX												RELAY SERIAL #																										
BREAKER # XXXXX												XXXXXXXXXX																										
-----TIME-- SYSTEM- -----INPUTS----- --OUTPUTS-- -----TIMERS-----																																						
H	M	S		B	L	S		5	D	D	B	H	L	L	R	R	P	P	C		C	T	S	M	T		L	L	R	R	P	P	L	R	R	S		
R	I	E		U	I	Y		2	T	T	L	S	T	T	P	P	A	F	E		L	R	Y	E	R		T	T	P	P	A	F	O	S	S	Y		
N	C		S	N	N		b	L	R	K	R	1	2	1	2	R					O	I	N	M	B		1	2	1	2	R				T	T	N	
				E	C																S	P	C	L												1	2	C
																					E			E														
HH:MM:SS.SH		0	0	0		0	0	0	0	0	0	0	0	0	0	0	0	0	0		0	0	0	0	0		0	0	0	0	0	0	0	0	0	0	0	0
HH:MM:SS.SH		1	1	0		1	0	0	0	0	0	0	0	0	0	0	0	0	0		0	0	0	0	0		0	0	0	0	0	0	0	0	0	0	0	0
HH:MM:SS.SH		1	0	0		0	1	0	0	0	0	0	0	0	0	0	0	0	0		0	0	0	0	0		0	0	0	0	0	0	0	0	0	0	0	0
HH:MM:SS.SH		1	1	0		0	0	1	0	0	0	0	0	0	0	0	0	0	0		0	0	0	0	0		0	0	0	0	0	0	0	0	0	0	0	0
HH:MM:SS.SH		1	-	0		0	0	0	0	0	0	0	0	0	0	0	0	0	0		0	0	0	0	0		0	0	0	0	0	0	0	0	0	0	0	0
HH:MM:SS.SH		1	1	0		0	0	0	0	0	0	0	0	0	0	0	0	0	0		0	0	0	0	0		0	0	0	0	0	0	0	0	0	0	0	0
HH:MM:SS.SH		1	1	1		0	0	0	0	0	0	0	0	0	0	0	0	0	0		0	0	0	0	0		0	0	0	0	0	0	0	0	0	0	0	0
..... more																																						
PRESS 'P' FOR PREVIOUS OR 'N' FOR NEXT RECORD AND ARROW KEYS TO SCROLL																																						
PRESS 'T' TO TRIGGER AN EVENT AND 'G' FOLLOWED WITH xx TO GO TO A RECORD																																						
PRESS 'ESC' TO RETURN TO REPORTS MENU																																						

Figure 3-17. Detailed Report Screen

BE1-25/79TR Functional Description

Programmable Outputs (Figure 3-18)

The purpose of this screen is to select the system conditions for the programmable outputs.

The initial default settings for all selections is NO. A parameter may be selected to operate either Programmable Output 1, Programmable Output 2, Programmable Output 3 or NONE when the condition exists. The LOSS OF POTENTIAL function is indicated when a potential goes dead while the breaker is closed. The LOCKOUT, PARALLEL MEMORY, and HIGH SPEED MEMORY functions are indications from the front panel target LEDs. The DEAD BUS-DEAD LINE, DEAD BUS-LIVE LINE, LIVE BUS-DEAD LINE, AND LIVE BUS-LIVE LINE FUNCTIONS are indications of the existing bus and line potentials. The RECLOSING IN PROGRESS function is indicated whenever the relay is not in RESET and is not in LOCKOUT.

When **ESC** is pressed after a settings change, a statement requesting verification of the setting changes is shown. A **Y** will incorporate all changes made to this screen into the setting table. An **N** will remove all changed settings from the NEW column.

Movement within the screen is controlled by the UP and DOWN arrow keys.

RELAY ID: XXXXXXXXXXXXXXXXXXXXXXXXX			
DATE: mm/dd/yy		TIME: hh:mm:ss	
PROGRAMMABLE OUTPUT CONTACTS			
1 = PROG 1 2 = PROG 2 3 = PROG 3 N = NONE			
	EXIST	NEW	
LOSS OF POTENTIAL	1/2/3/N	1/2/3/N	
LOCKOUT	1/2/3/N	1/2/3/N	
PARALLEL MEMORY	1/2/3/N	1/2/3/N	
HIGH SPEED MEMORY	1/2/3/N	1/2/3/N	
DEAD BUS - DEAD LINE	1/2/3/N	1/2/3/N	
DEAD BUS - LIVE LINE	1/2/3/N	1/2/3/N	
LIVE BUS - DEAD LINE	1/2/3/N	1/2/3/N	
LIVE BUS - LIVE LINE	1/2/3/N	1/2/3/N	
RECLOSING IN PROGRESS	1/2/3/N	1/2/3/N	
PRESS 'ESC' TO RETURN TO MAIN MENU			

Figure 3-18. Programmable Outputs Screen

SECTION 4

INSTALLATION

GENERAL

When not shipped as part of a control or switchgear panel, BE1-25/79TR Sync-Check Reclosing Relays are shipped in sturdy cartons to prevent damage during transit. Immediately upon receipt, check the model and style number against the requisition and packing list to see that they agree. Visually inspect it for damage that may have occurred during shipment. If there is evident damage, immediately file a claim with the carrier and contact a sales representative at Basler Electric, Highland, Illinois.

In the event the unit is not to be installed immediately, store it in its original shipping carton in a moisture and dust free environment. It is strongly recommended that a confidence test (described later in this section) always be performed prior to installation.

OPERATING PRECAUTIONS

Before installation or operation, observe the following precautions.

1. Always be sure that external operating (monitored) conditions are stable before removing a relay for inspection, testing, or servicing.
2. BE1-25/79TR Sync-Check Reclosing Relays are solid-state devices and have been type tested in accordance with the requirements defined in the following paragraph, Dielectric Test. If a wiring insulation test is required on the switchgear or panel assembly of which this unit is a part, observe the following paragraph, Dielectric Test.
3. Be sure that the relay chassis is hard wired to earth ground using the chassis ground terminal on the rear of the relay.
4. When the relay is in service, the controls should be protected by the cover supplied. This limits access to the control settings.

DIELECTRIC TEST

Relays have been type tested in accordance with the requirements of IEC 255-5 and ANSI/IEEE C37.90.1-1989. One-minute dielectric (high potential) tests of the assembled switchgear or control panel wiring may be performed at voltage levels up to 1500 Vac (45-65 Hz). Note the following:

1. Decoupling capacitors (0.001 μ F) are employed on the voltage input terminals to chassis ground. Accordingly, a leakage current of approximately 5.6 mA per terminal point is to be expected when high potting at 1500 Vac, 60 Hz.
2. Varistors are connected across the following terminals:
 - Power supply
 - Contact sensing inputs
 - Relay output contacts.

Only communication terminals, and the line and bus input terminals do **NOT** have varistors installed.

BE1-25/79TR Installation

MOUNTING

General

BE1-25/79TR Sync-Check Reclosing Relays are designed to be either rack- or panel-mounted. Overall dimensions are shown in Figure 4-1. Alternatively, the unit may be panel mounted at any convenient angle, using the cutout dimensions of Figure 4-2 as a guide. When panel mounting the relay, an optional escutcheon plate can be installed to cover variations in panel cutouts. Figure 4-3 shows the mounting flanges removed and the escutcheon plate installed. Figure 4-4 shows the mounting flange and alternate location that requires less mounting depth. Specific relays by part number are available for mounting vertically.

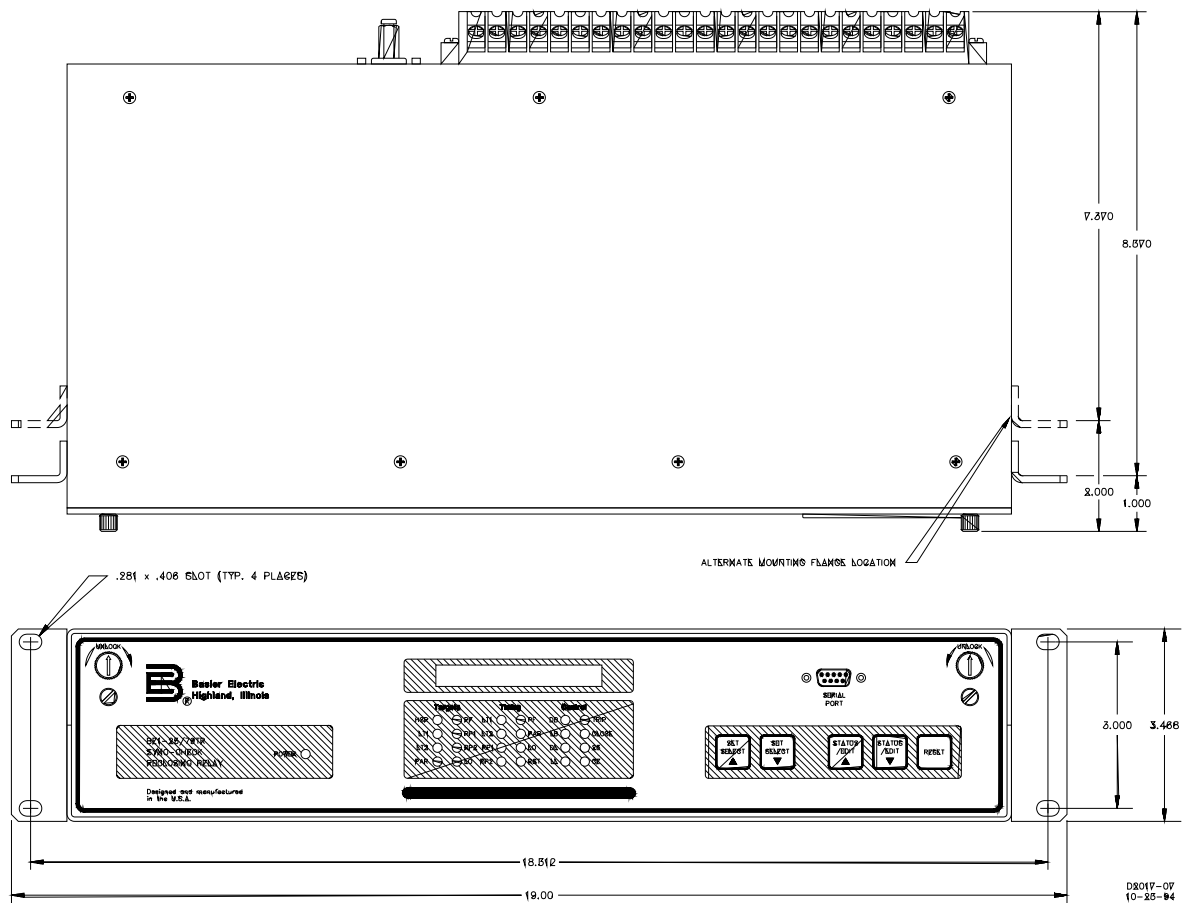

Figure 4-1. Outline Dimensions (Rack Mounting)

BE1-25/79TR Installation

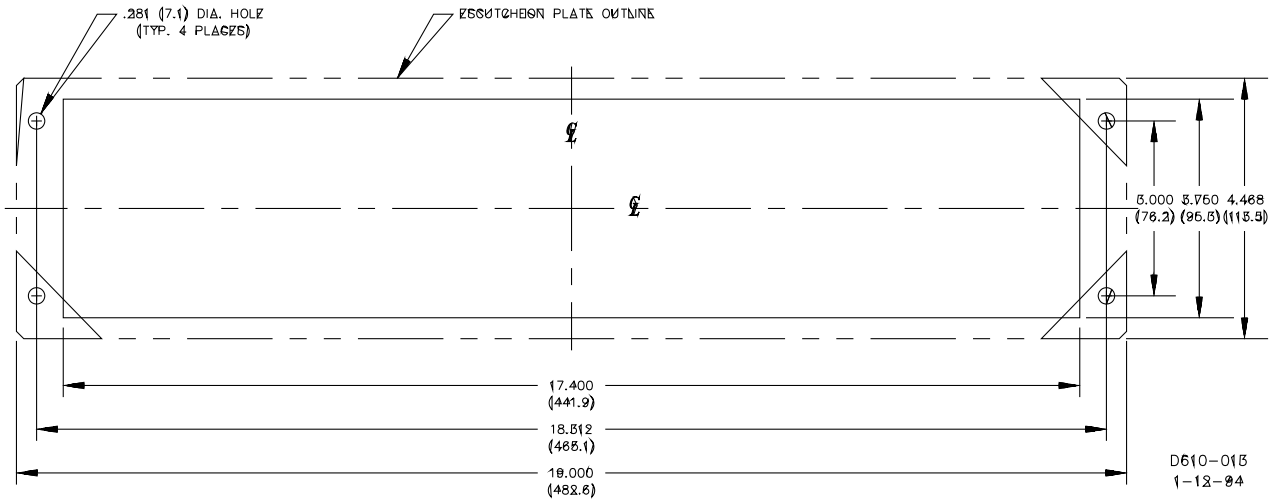
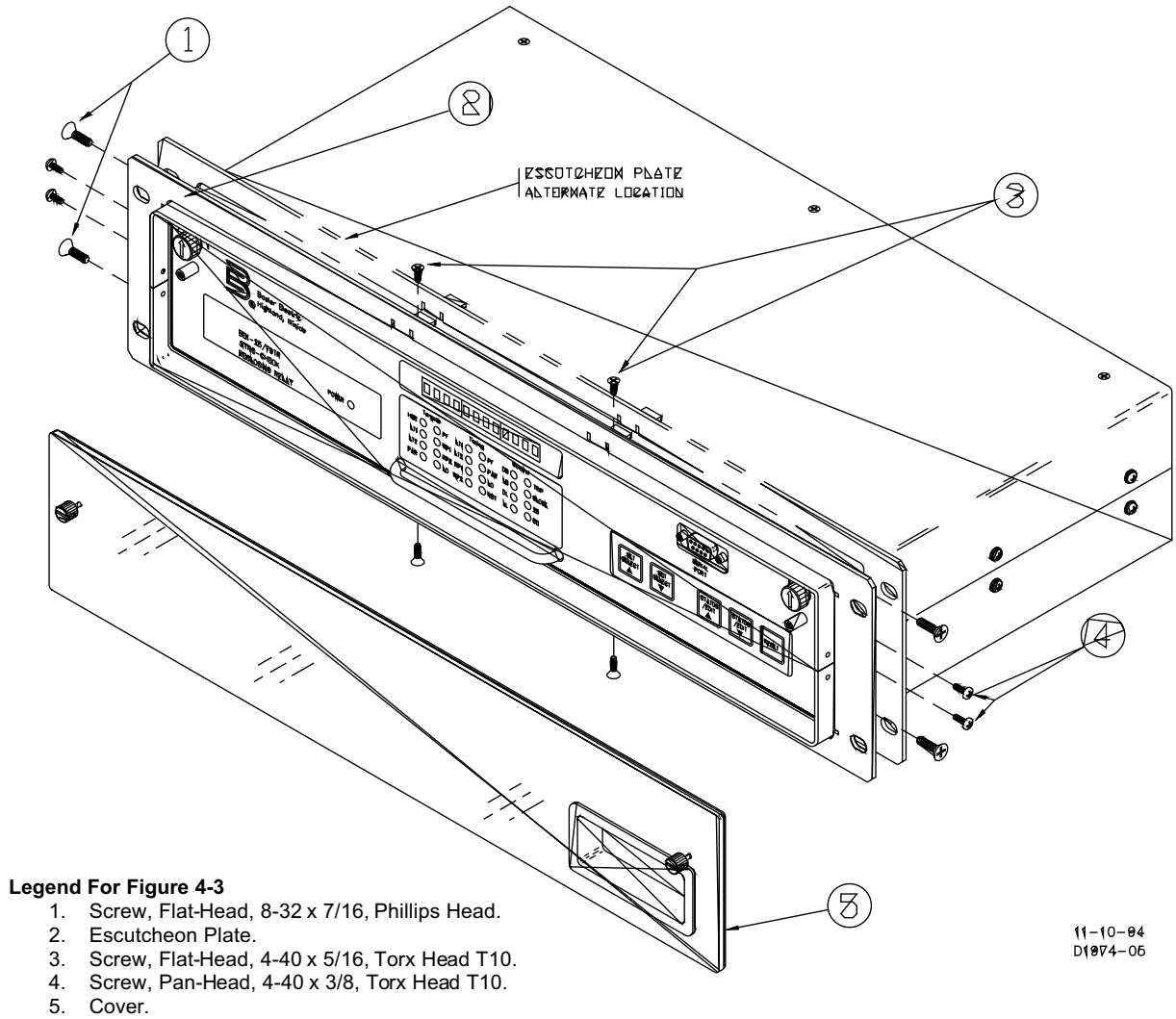

Figure 4-2. Cutout Dimensions (for Non-Rack Mounting)



Legend For Figure 4-3

1. Screw, Flat-Head, 8-32 x 7/16, Phillips Head.
2. Escutcheon Plate.
3. Screw, Flat-Head, 4-40 x 5/16, Torx Head T10.
4. Screw, Pan-Head, 4-40 x 3/8, Torx Head T10.
5. Cover.

Figure 4-3. Escutcheon Plate Mounting

BE1-25/79TR Installation

Installing Escutcheon Plates

To install the escutcheon plate kit (Basler part number, 9 2720 13 100) you must first remove the mounting flanges by removing the four screws (1) from the relay (two from each side). To allow the escutcheon plate to slide onto the relay, remove the four screws (4) from the relay (two from each side).

To install the escutcheon plate in the standard location, it is also necessary to remove four screws (3), two each from the relay top and bottom. Position the escutcheon plate at the standard location and reinstall the attaching hardware.

When installing the escutcheon plate at the alternate location (requires less space behind the mounting panel), position the escutcheon plate in the alternate location and install the four screws (3) that are provided with the optional escutcheon plate kit. Refer to Figure 4-3 or 4-4 for the alternate location side view. Reinstall four screws (4). Reinstall the four screws (1) through the escutcheon plate into the relay at the alternate location.

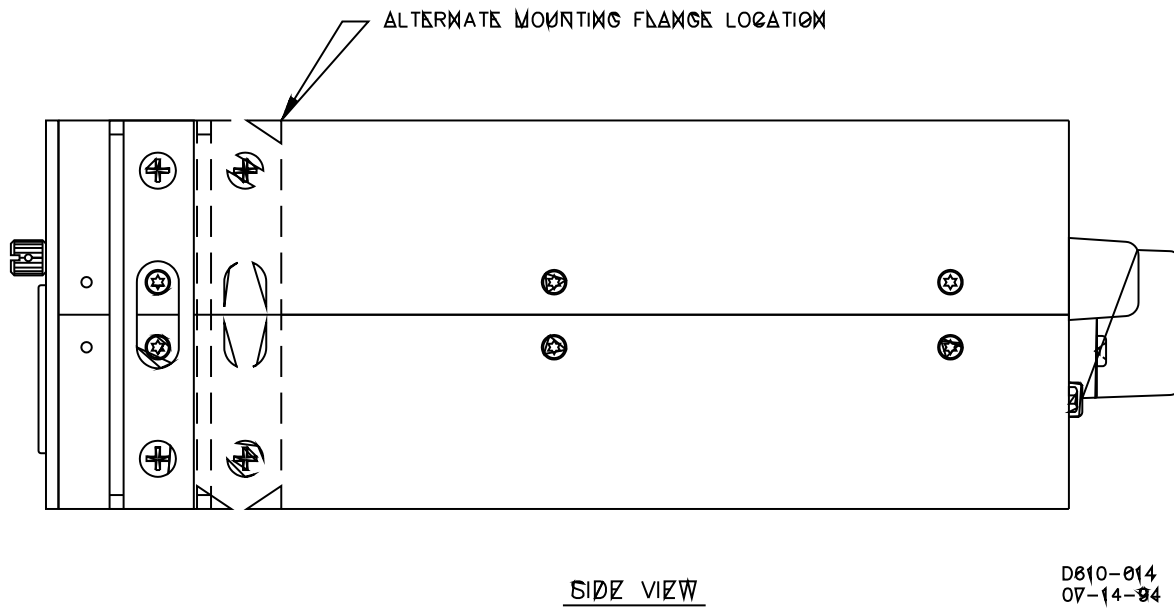

Figure 4-4. BE1-25/79TR Alternate Mounting Location

CONNECTIONS

It is important to provide a ground connection for chassis ground. Terminals of BE1-25/79TR Sync-Check Reclosing Relays are identified in Figure 4-5 (Typical External Connections). All terminals are suitable for use with wire sizes of 14 AWG or smaller. Typical connection diagrams are shown in Figures 4-6 and 4-7. Figure 4-8 shows a typical connection diagram, for BE1-25/79TR Sync-Check Reclosing Relay assigned to loop station line circuit breaker. Figures 4-9 and 4-10 provide the connections (pinout diagrams) for RS 232-C terminals. Incorrect wiring may result in damage to the unit.

NOTE

Be sure the relay is hard-wired to earth ground with no smaller than 12 AWG copper wire attached to the ground terminal on the rear of the relay case. When the relay is configured in a system with other protective devices, it is recommended to use a separate lead to the ground bus from each relay.

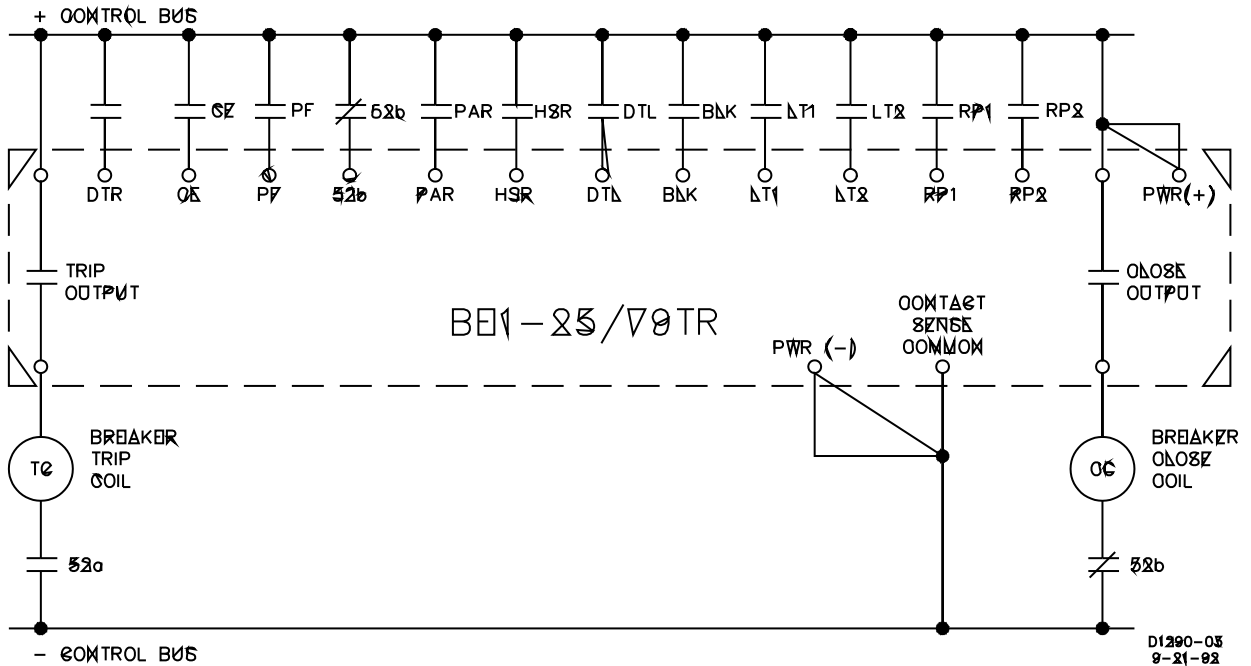
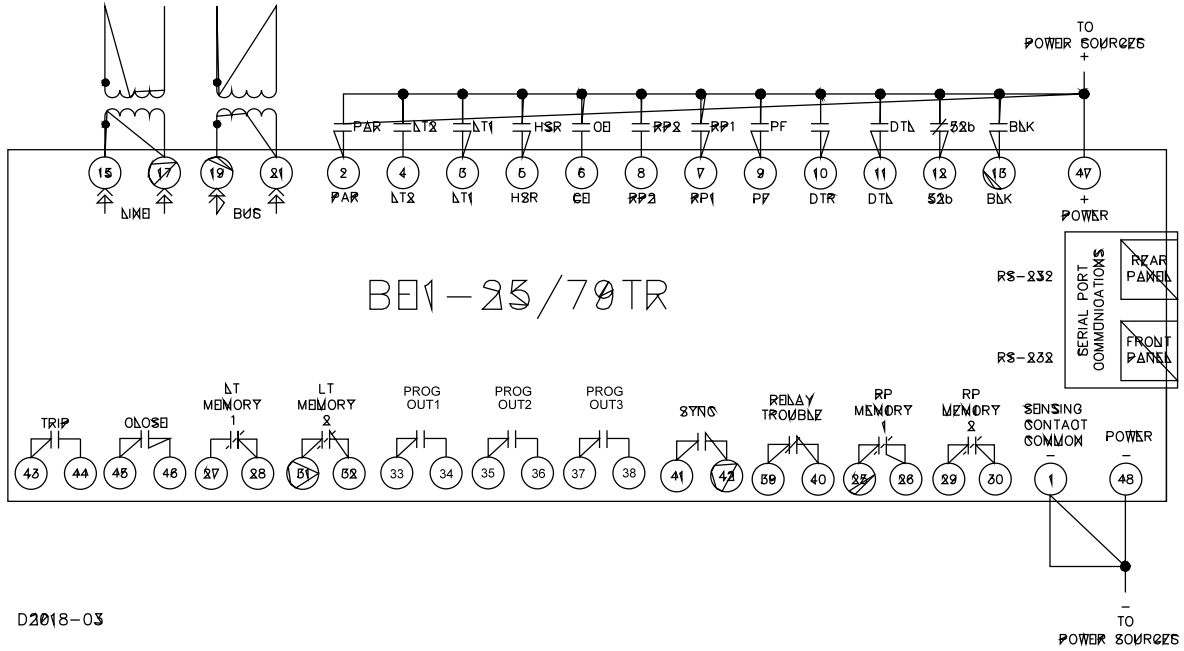

Figure 4-5. Typical External Connections

BE1-25/79TR Installation



D2018-03

Figure 4-6. Typical Connection Diagram - Single Phase

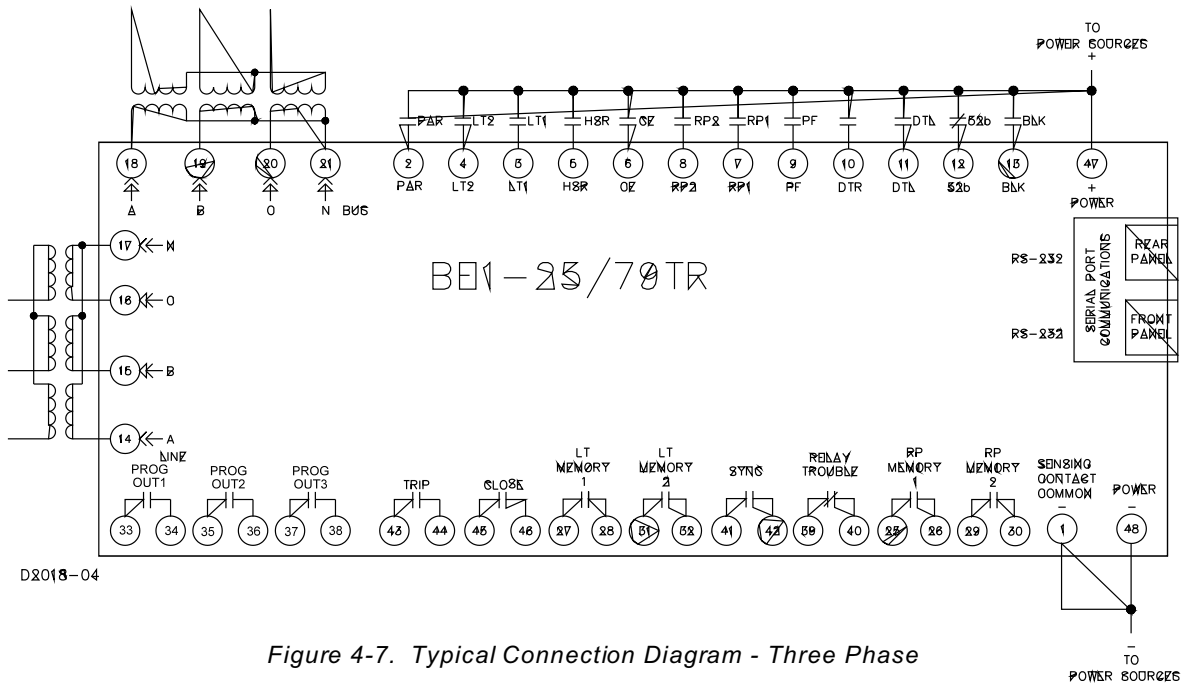

D2018-04

Figure 4-7. Typical Connection Diagram - Three Phase

BE1-25/79TR Installation

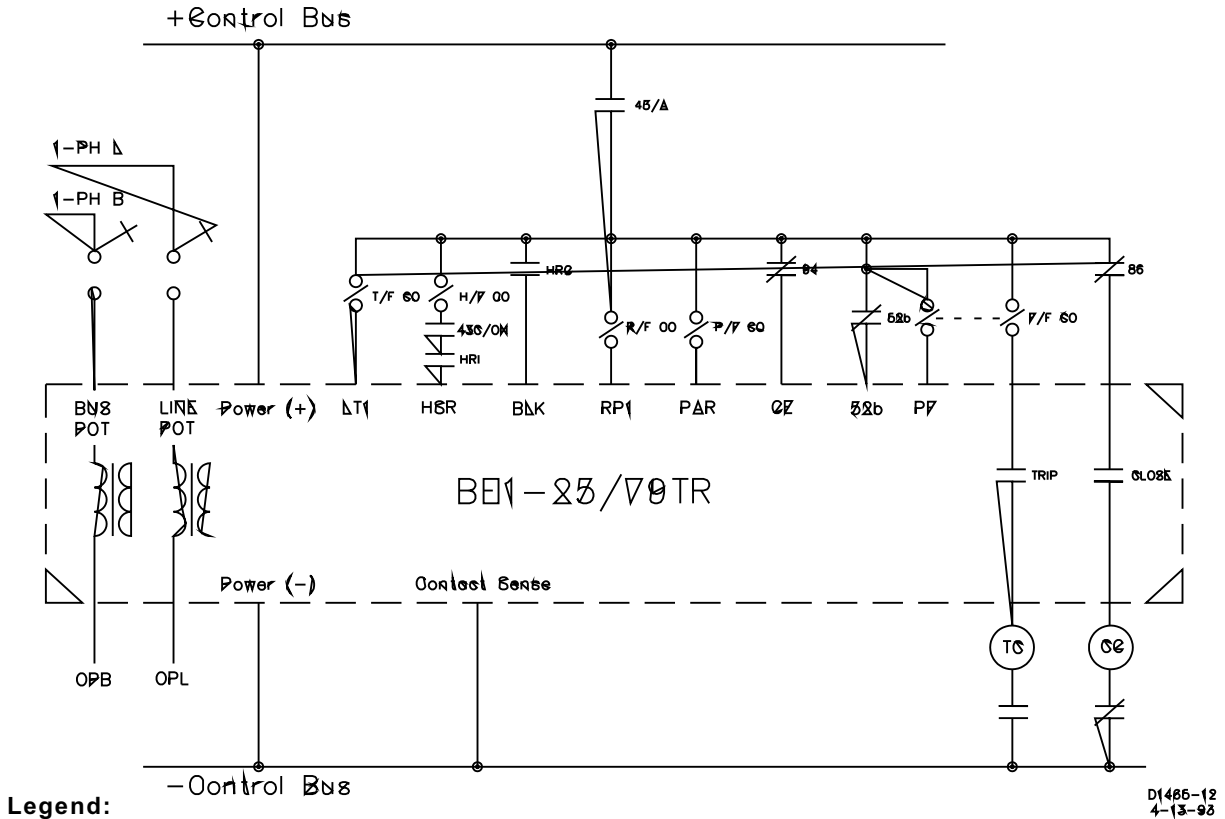
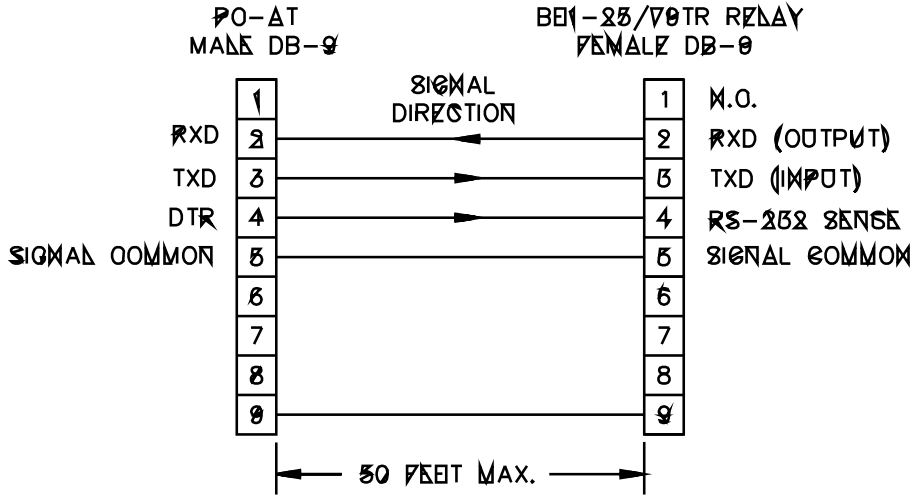
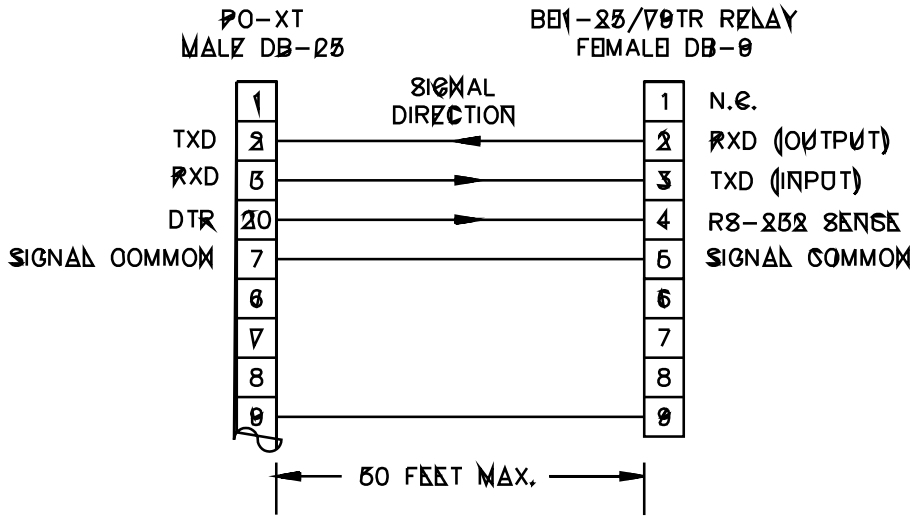

Figure 4-8. Typical Connection Diagram, for BE1-25/79TR
Sync-Check Reclosing Relay Assigned To Loop Station Line Circuit Breaker

BE1-25/79TR Installation



PO-AT TO BE1-25/79TR RELAY



PO-XT TO BE1-25/79TR RELAY

D688-005
2-9-84

Figure 4-9. RS 232 Interconnection Diagram For IBM Type Computers

BE1-25/79TR Installation

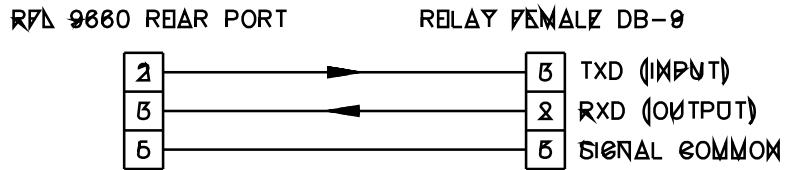

RFL 9660 PROTECTIVE RELAY SWITCH TO BE1-25/79TR RELAY

D1615-15
2-9-84

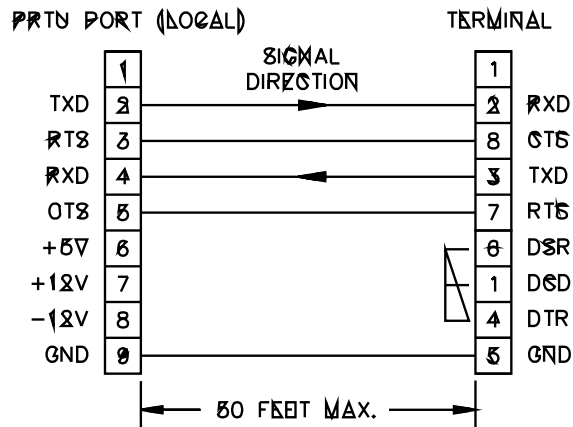

PROTECTIVE RELAY TERMINAL UNIT (PRTU) TO DATA TERMINAL EQUIPMENT (DTE)

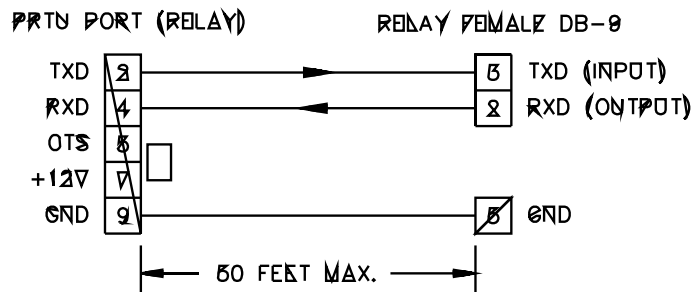

PROTECTIVE RELAY TERMINAL UNIT (PRTU) TO BE1-25/79TR RELAY

D1545-15
2-9-84

Figure 4-10. RS 232 Interconnection Diagram For Protective Relay Terminals

SECTION 5

TESTING

GENERAL

A BE1-25/79TR Test Simulator (shown in Figure 5-1) makes testing BE1-25/79TR relays much easier. All contact sensing inputs and enable inputs are simulated by toggle switches that are easily accessible on the front panel. Appropriate LEDs provide BE1-25/79TR relay functional indications. Additionally, the test procedures in this section use the Test Simulator switch and LED names. A Test Simulator schematic diagram is provided in Figures 5-2 and 5-3.

TESTING

Testing BE1-25/79TR relays requires that they be isolated from the controlled system. A bench-test setup that would be appropriate is illustrated in Figure 5-4.

The test is divided into eight different functional areas. The functional areas are:

- Time, Date, Settings, and Save.
- Timers.
- Control Inputs.
- Voltage Monitor.
- Voltage Difference Inhibit.
- Sync LB and LL Inhibit.
- Phase Accept.
- Slip Frequency Difference.

The tests are organized so that testing may be started at any functional area. All test measurements have a tolerance of $\pm 5\%$.

Preliminary Setup Procedures

- Step 1. Connect the test circuit as shown in Figure 5-4. (Connect the appropriate contact sense input voltage to terminals 19 and 20 on the test set.)
- Step 2. Close the simulated breaker by operating the test set MANUAL CLOSE switch (the test set 52a LED should light)
- Step 3. Open all input switches on the test set.
- Step 4. Apply nominal power supply voltage to the power input terminals and the contact sensing input on the test set.

The Power LED on the relay should light.

BE1-25/79TR Testing

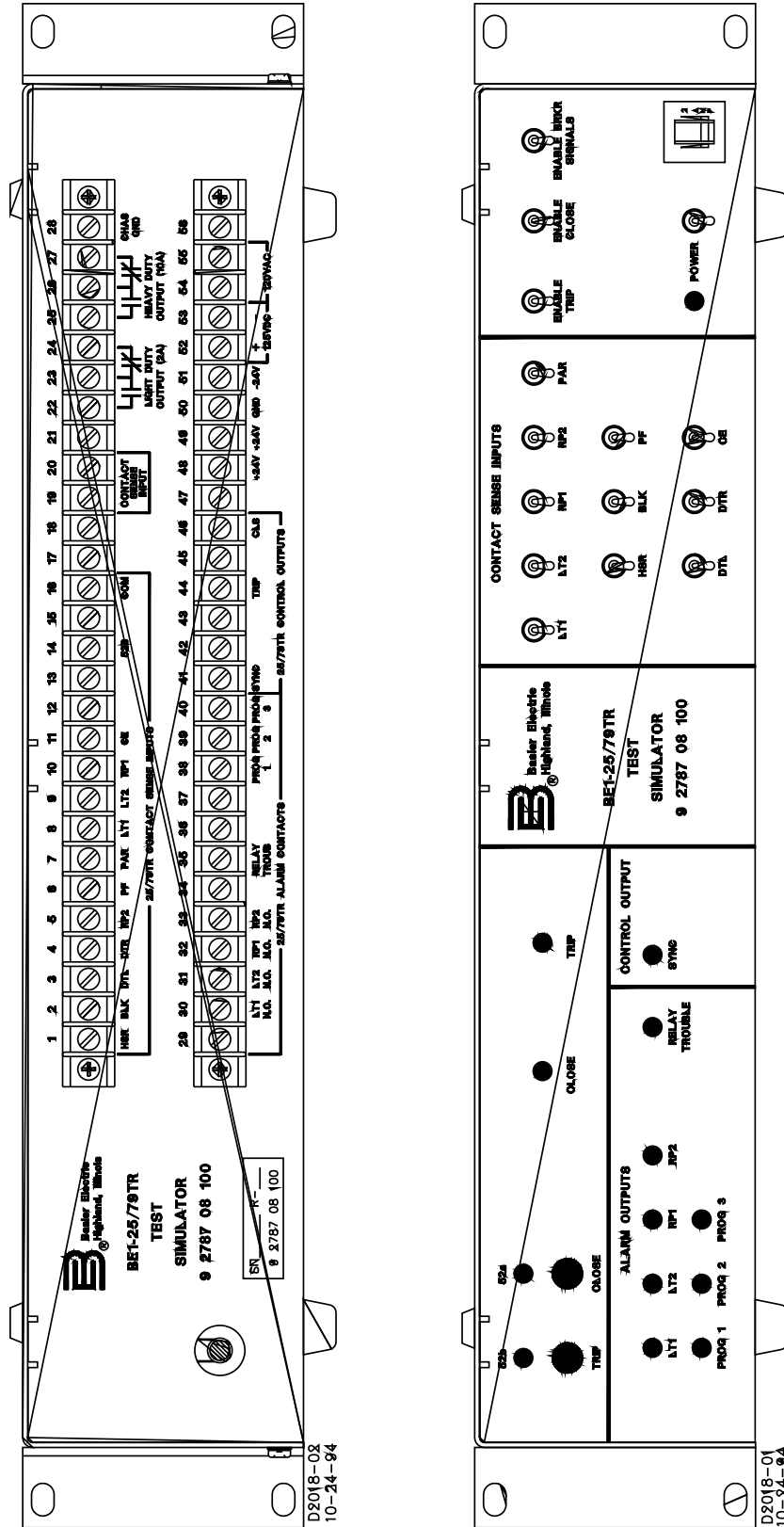

Figure 5-1. BE1-25/79TR Test Simulator

BE1-25/79TR Testing

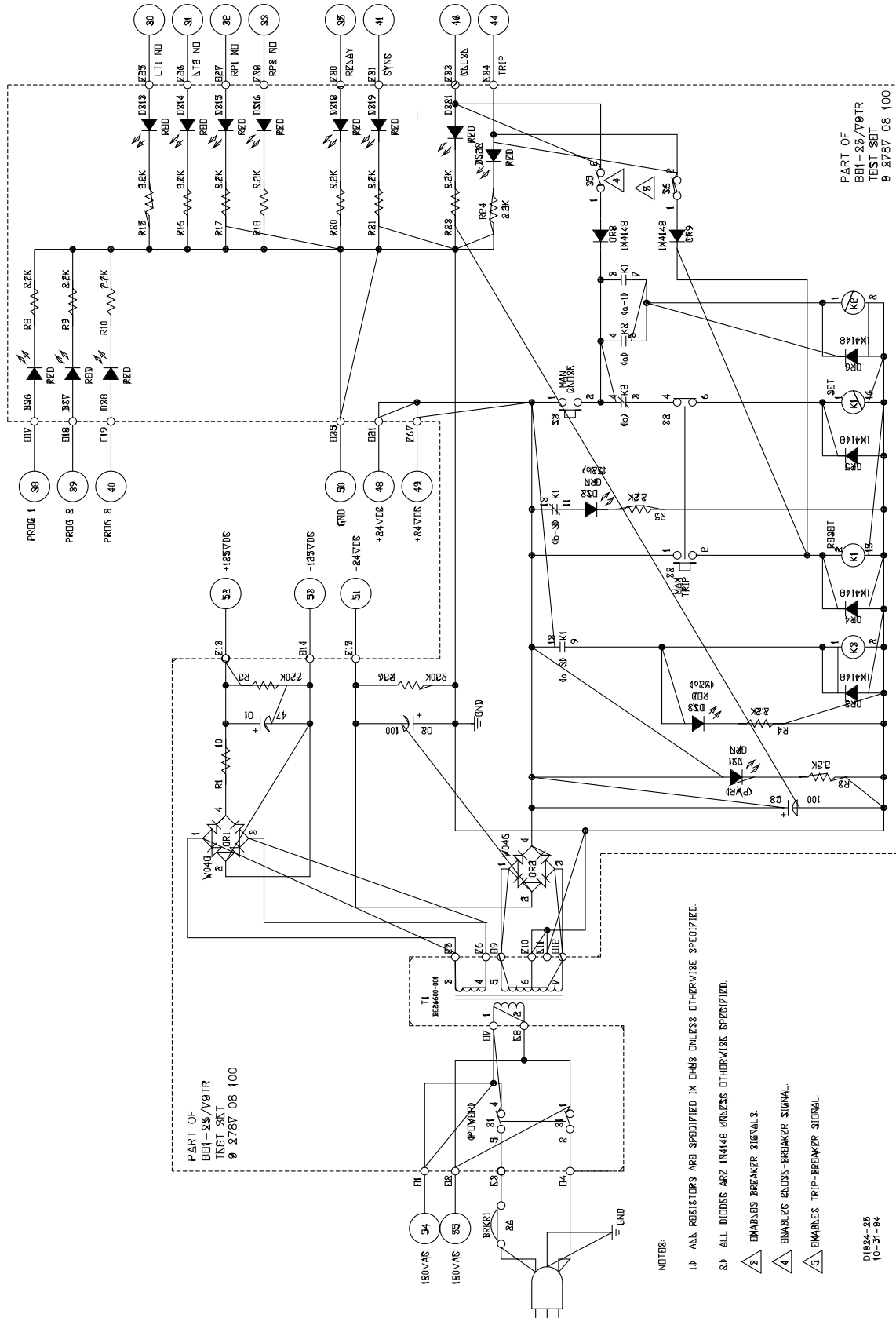

Figure 5-2. BE1-25/79TR Test Simulator, Schematic Diagram (Sheet 1 of 2)

BE1-25/79TR Testing

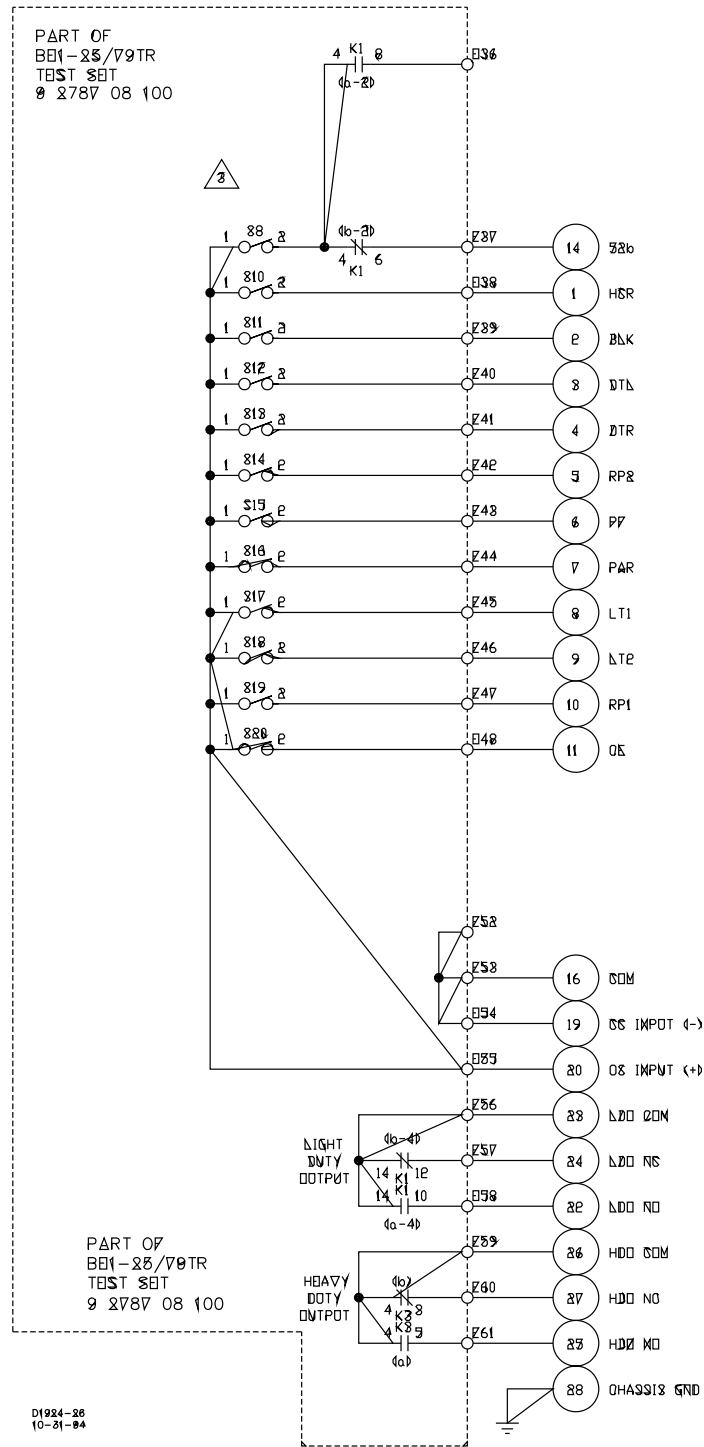

Figure 5-3. BE1-25/79TR Test Simulator, Schematic Diagram (Sheet 2 of 2)

BE1-25/79TR Testing

D1082-11
10-24-84

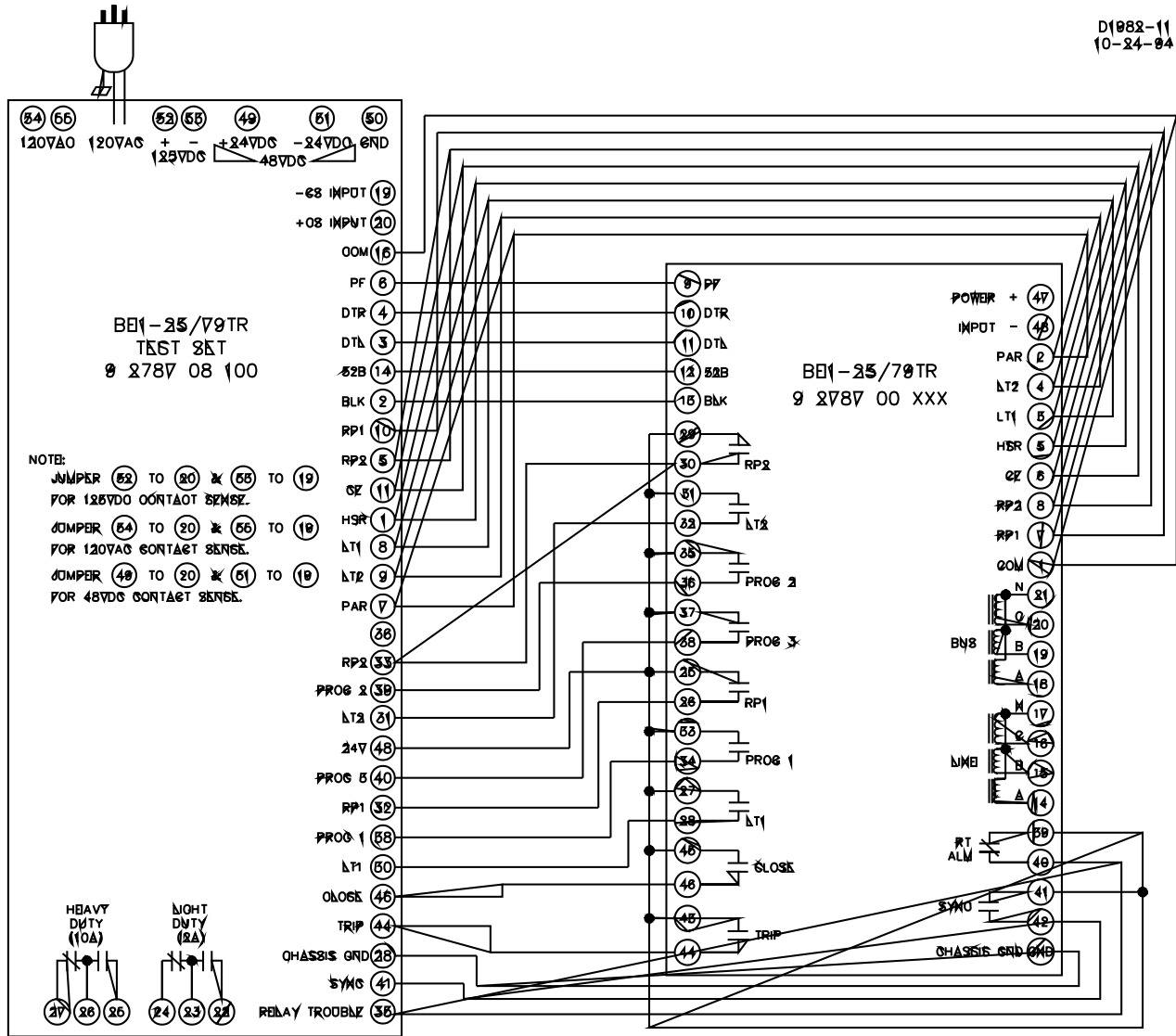

Figure 5-4. Test Setup Diagram

BE1-25/79TR Testing

Time, Date, Settings, and Save

- Step 1. Perform the preliminary setup procedures.
- Step 2. Use the relay Set Select and Status/EDIT switches to set the current time and date.
- Step 3. Load the desired timer and voltage settings.
- Step 4. Operate the Reset switch up so that SAVE SETUP? is displayed.
- Step 5. Operate (up) the Status/EDIT Up switch again so that SAVING SET is displayed.
- Step 6. Verify that all information is held during a loss of input power by removing and then applying input power.
- Step 7. Operate the Status/EDIT switch to view settings and verify that they are retained.

Timers

- Step 1. Perform the preliminary setup procedures.

LT1 Timer

- Step 2. Close the CE (counter enable), switch on the test set. Enable breaker, enable close and enable trip.
- Step 3. Set the line voltage at a dead level and the bus voltage at a live level.
- Step 4. Close the LT1 switch and operate the MANUAL TRIP switch on the test set.

Observe LT1 timer counts down, the test set breaker closes and the LT1 target LED lights.

LT2 Timer

- Step 5. Open the test set LT1 switch and close the LT2 switch.
- Step 6. Operate the MANUAL TRIP switch and observe that the test set breaker closes and the LT2 target LED lights after the LT2 timer counts down.
- Step 7. Operate the Reset switch and observe that both LT1 and LT2 target LEDs extinguish.

RST1 Timer

- Step 8. Trip the test set breaker.
- Step 9. After the LT2 timer expires and the test set breaker closes, trip the breaker.
- Step 10. Wait for the LO target LED to light (indicates lockout).
- Step 11. Operate the MANUAL CLOSE switch on the test set and verify that the time from when the test breaker closes until the relay LT2 contacts open equals the desired reset time.
- Step 12. Open the LT2 switch on the test set.

RP1 Timer

BE1-25/79TR Testing

Step 13. Set the line voltage at a live level and the bus voltage at a dead level.

Step 14. Close the RP1 switch on the test set and trip the test set breaker.

Observe that the test set breaker closes and the RP1 target LED lights after the RP1 timer counts down.

RP2 Timer

Step 15. Open the test set RP1 switch and close the RP2 switch.

Step 16. Trip the test set breaker and observe that after the RP2 timer counts down, the test set breaker closes and the RP2 target LED lights.

Step 17. Verify that the RP targets extinguish when the Reset switch is operated.

Step 18. Open the RP2 switch on the test set.

PAR Timer

Step 19. Set the line and bus voltages at live levels, in phase, at system frequency.

Step 20. Close the PAR switch on the test set and trip the breaker.

Verify that the time from when the sync contacts close until the test set breaker closes equals the desired parallel time delay.

Step 21. Open the PAR switch.

Verify that the PAR target LED extinguishes when the Reset switch is operated.

HSR Timer

Step 22. Trip the test set breaker and momentarily close the HSR switch on the test set.

After the HSR timer counts down, the test set breaker should close and the HSR target LED should be ON. If high speed reclosing is being supervised by the sync function (HSR-SYNC YES in the settings mode) then a high speed reclosure may not be initiated until sync contact closure occurs.

Step 23. Operate the Reset switch and observe that the HSR target LED extinguishes.

Sync-Check Timer

Step 24. Trip the test set breaker.

After the sync time delay expires, the sync contacts should close and the relay 25 LED should be ON.

Close breaker.

BE1-25/79TR Testing

Close Timer

Step 25. Open ENABLE CLOSE switch on the test set.

Step 26. Close test set PAR switch.

Step 27. Trip the test set breaker.

Verify that after the PAR time delay expires, the relay close contacts close for the time duration programmed.

Step 28. Close the test set breaker and reset relay targets.

LO Timer

Step 29. Trip the test set breaker.

After the PAR timer expires, the close contacts should close for the duration programmed.

Verify that the LO timer starts counting down when the close contacts open. After the LO timer has timed out, verify that the LO and PAR target LEDs are ON.

Step 30. Close the test set breaker and ENABLE CLOSE switch, open the test set PAR switch, and reset the relay targets.

LOP Timer

Step 31. Use SET SELECT and Status/EDIT switches to set LOP timer to 100. Save setup using Status/EDIT and RESET switches.

Step 32. Set line voltage at a live level and bus voltage at a dead level. Close RP1 and trip test set breaker. Observe that reclose does not occur. Reclose breaker and open RP1.

Control Inputs

PF Timer

Step 1. Perform the preliminary setup procedures. Set the line and bus voltages to dead levels.

Step 2. Close the test set PF switch.

Verify that the PF timer starts counting down when the PF switch is closed and the test set breaker opens when the PF timer has expired.

Step 3. Open the test set PF switch and close the test set breaker.

BLK Reclosing

Step 4. Set the line and bus voltages at live levels and in phase at system frequency.

Step 5. Close the BLK switch on the test set.

BE1-25/79TR Testing

Step 6. Trip the test set breaker and momentarily close the test set HSR switch.

A high speed reclosure should NOT occur.

Step 7. Open the test set BLK switch and close the test set breaker.

CE

Step 8. Close the test set PAR switch.

Step 9. Operate the relay Status/EDIT switch until the MASTER TIMER is displayed.

Step 10. Trip the test set breaker and observe that the master timer starts counting down.

Step 11. Open the CE switch on the test set.

Observe that the master timer stops counting down.

Step 12. Close the CE switch and verify that the master timer resumes counting.

Step 13. Open the test set PAR switch.

DTL

Step 14. With the test set breaker closed and the relay RST LED ON, close the DTL switch on the test set.

Observe that the RST LED extinguishes and the LO LED lights.

Step 15. Open the test set DTL switch.

Verify that after the RST1 timer expires, the relay LO LED extinguishes and RST LED lights.

DTR

Step 16. Open the test set ENABLE CLOSE switch.

Step 17. Close the test set PAR switch.

Step 18. Trip the test set breaker.

Observe that after the PAR timer expires, the PAR target LED lights, and after the LO timer expires, the LO target LED lights.

Step 19. Open the test set PAR switch.

Step 20. Momentarily close the test set DTR switch.

Verify that the PAR and LO target LED's extinguish and the RST LED lights.

Step 21. Close the test set ENABLE CLOSE switch and breaker.

BE1-25/79TR Testing

Voltage Monitor

- Step 1. Perform the preliminary setup procedures.
- Step 2. Vary the bus and line voltage and observe that the DB, DL, LB, and LL LEDs light and extinguish at the proper levels and that the relay Status display shows the correct voltages for each condition. The displayed voltage should be within 5% of the applied voltage.

Voltage Difference Inhibit

- Step 1. Perform the preliminary setup procedures.
- Step 2. Apply sufficiently high, identical voltages to the line and bus inputs so that the relay LL and LB LEDs are ON.
- Step 3. Increase or decrease one of the input voltages until the LL and LB LEDs start flashing.

The difference between the bus and line voltages should equal, $\pm 5\%$, the DELTA V setting of the relay.
- Step 4. Trip the test set breaker and verify that closure of the sync contacts does NOT occur.

Sync LB and LL Inhibit

- Step 1. Perform the preliminary setup procedures.
- Step 2. Apply voltages that are lower than the relay LL and LB settings.

The relay LL and LB LEDs should NOT be ON.
- Step 3. Trip the test set breaker and verify that no sync contact closure occurs.

Phase Accept

- Step 1. Perform the preliminary setup procedures.
- Step 2. Apply identical line and bus voltages that are high enough to light the relay LL and LB LEDs.
- Step 3. Trip the test set breaker.
- Step 4. Adjust the phase angle of the line input to a leading value greater than the relay phase window setting.

Observe that the LL and LB LEDs flash ON and OFF.
- Step 5. Reduce the line voltage phase angle until the relay voltage LEDs stop flashing.

After the sync time delay expires, the relay 25 LED should be ON and the sync contacts should be closed. The measured phase angle should be ± 1 degree of the relay phase window setting.
- Step 6. Operate the relay Status/EDIT switch until the phase angle is displayed.

The displayed phase angle should be ± 1 degree of the measured phase angle.
- Step 7. Close the test set breaker and observe that the sync contacts open.

BE1-25/79TR Testing

Step 8. Trip the test set breaker and wait for the sync contacts to close.

Step 9. Increase the phase angle until the sync contacts open.

The measured phase angle should be $\pm 1\%$ of the phase window setting and the displayed phase angle on the relay should be $\pm 1\%$ of the measured phase angle.

Step 10. Repeat the above step for a lagging phase angle.

Slip Frequency Difference

Step 1. Perform the preliminary setup procedures.

Step 2. Set the line and bus voltages at live levels, in phase, at system frequency. Set the phase angle window > 180 degrees to disable the phase window.

Step 3. Lower the frequency of the line voltage until the LB and LL LEDs start flashing.

The line voltage frequency should be equal to system frequency minus the relay slip frequency difference setting, $\pm .05$ Hz.

Step 4. Operate the relay Status/EDIT switch until F SLIP is displayed.

The displayed frequency should be equal to the relay slip frequency difference setting, ± 0.05 Hz.

Step 5. Return the line frequency to system frequency.

Step 6. Raise the line frequency until the LB and LL LEDs start flashing.

The frequency of the line voltage should be equal to system frequency plus the relay slip frequency difference setting, $\pm .05$ Hz. The displayed frequency on the relay should be equal to the relay slip frequency difference setting, $\pm .05$ Hz.

Programmable Outputs

Step 1. Connect unit to computer as explained under COMMUNICATIONS in Section 3. Press ESC to get to Main Menu. Press 5 then Password (TR default). Press Enter to get to Programmable Outputs Menu.

Step 2. Select the following:

Loss of Potential	1	Parallel Memory	3
Lockout	2	Others	N

Press ESC then Y to save changes.

Step 3. Apply bus and line voltage at a live level. Close the test set breaker. Lower line or bus voltage to dead level. Verify that PROG 1 closes after LOP TD times out.

Step 4. Apply live level voltage to bus and line. Close PAR switch. Trip breaker and verify that after PAR times out, breaker closes and PROG 3 closes.

Step 5. Close DTL and verify PROG 2 closes.

CALIBRATION

To calibrate the relay, perform the following steps.

- Step 1. Perform the preliminary setup procedures.
- Step 2. Operate the Settings Select UP or DOWN switch and observe SETTINGS MDE indicated on display.
- Step 3. Operate the Settings Select UP or DOWN switch until CAL MODE NO is indicated on display.
- Step 4. Operate the Status/EDIT Up switch and observe CAL MODE YES indicated on display.
- Step 5. Operate the Reset switch while holding the Status/EDIT Up and observe Sel Sys Freq indicated on display.
- Step 6. To select 50 Hz or 60 Hz operation, operate Settings Select UP or DOWN switch:
 - UP for 60 Hz?
 - DOWNfor 50 Hz?
- Step 7. Verify the selection of system frequency by operating Status/EDIT Up switch and observe that the following is displayed.

60 Hertz

- Cal Mode 3 ph and Apply 110V if relay is 3 phase.
- Cal Mode 1 ph and Apply 110V if relay is 1 phase.

50 Hertz

- Cal Mode 3 ph and Apply 100V if relay is 3 phase.
- Cal Mode 1 ph and Apply 100V if relay is 1 phase.

- Step 8. Apply specified voltage to bus and line inputs then operate the Settings Select UP for at least one second.
- Step 9. Observe the results.

If a good calibration was achieved, the display will flash the following different displays.

If single phase type relay:

- Phase Cal
- Line 1 Ph
- Cal OK Line
- Bus 1 Ph
- Cal OK Bus

followed by: 1 Ph Rng Done.

BE1-25/79TR Testing

Step 9 - Continued

If three phase type relay:

- Phase Cal
- Line 3 Ph
- Cal OK Ln A
- Cal OK Ln B
- Cal OK Ln C
- Bus 3 Ph
- Cal OK Bus A
- Cal OK Bus B
- Cal OK Bus C

followed by: 3 Ph Rng Done.

If calibration was not achieved, the display will indicate if the input voltage for the bus or line was too high or too low. Repeat Step 8 and observe the results.

If calibration was achieved, CAL MODE NO is displayed.

To exit the calibration mode, operate the Reset switch.

SELF TEST

To execute the self diagnostic program (TEST), perform the following steps.

- Step 1. Perform the preliminary setup procedures.
- Step 2. Operate Set Select UP or DOWN switch and observe SETTINGS MDE indicated on display.
- Step 3. Operate Set Select UP or DOWN switch until TST MODE NO is indicated on display.
- Step 4. Operate Status/Edit Up switch and observe TST MODE YES indicated on display.
- Step 5. Press the Reset switch while holding the Status/EDIT Up switch.
- Step 6. Close the following listed contact sensing inputs and observe that the associated front panel LED is turned ON. Close Enable Breaker Signals switch.

Contact Sensing Input	Front Panel LED
HSR	HSR (Target)
LT1	LT1 (Target)
LT2	LT2 (Target)
PAR	PAR (Target)
PF	PF (Target)
RP1	RP1 (Target)
RP2	RP2 (Target)
CE	CE (Control)
DTL	LO
52b	DL
BLK	LL
DTR	25

BE1-25/79TR Testing

Step 7. Verify that all contact sensing inputs are open. Operate the Status/EDIT Down switch.

Observe that the relay completes the pre-programmed test sequence. The sequence of events (tests) is as follows:

- HSR Target LED ON
- LT1 Target LED ON
- LT2 Target LED ON
- PAR Target LED ON
- PF Target LED ON
- RP1 Target LED ON
- RP2 Target LED ON
- LO Target LED ON
- LT1 Timing LED ON
- LT2 Timing LED ON
- RP1 Timing LED ON
- RP2 Timing LED ON
- PF Timing LED ON
- PAR Timing LED ON
- LO Timing LED ON
- RST Timing LED ON
- DB Control LED ON
- LB Control LED ON
- DL Control LED ON
- LL Control LED ON
- TRIP Control LED ON
- CLOSE Control LED ON
- 25 Control LED ON
- CE Control LED ON
- CLOSE contacts close
- TRIP contacts close
- N.O. PROG 1 contacts close.
- N.O. PROG 2 contacts close.
- N.O. PROG 3 contacts close.
- LT1 contact closes.
- LT2 contact closes.
- RP1 contact closes.
- RP2 contact closes.
- Normally closed RT ALM contacts opens.
- SYNC contacts close
- Allows Step 6 to be performed.

Step 8. To terminate the test, operate the Reset switch.

LOADING FACTORY DEFAULT SETTINGS

Factory default settings are primarily used during factory testing.

Factor Default Settings

Factory default settings are:

MASTER TD	35	SEC
RST 1 TD	5	SEC
RST 2 TD	10	SEC
HSR TD	99	CYCLES
LT1 TD	5	SEC
LT2 TD	10	SEC
RP1 TD	15	SEC
RP2 TD	20	SEC
PAR TD	25	SEC
SYNC TD	300	CYCLES
PF TD	10	SEC
LO TD	4	SEC
DEAD BUS	30	VOLTS
DEAD LINE	30	VOLTS
LIVE BUS	80	VOLTS
LIVE LINE	80	VOLTS
PHASE W	5	DEGREES
DELTA V	20	VOLTS
F SLIP W	0.50	HERTZ
CLOSE TD	2	SEC
HSR-SYNC	0	0=N,1=Y
START 52B	0	0=N,1=Y
BKR RECG	2	x4 MSEC
LOP TD	0	x10 MSEC
ADDRESS	125	
BAUD RATE	19200	FRONT
BAUD RATE	19200	REAR

Load Default Settings

- Step 1. Operate the Set Select UP or DOWN switch and observe that SETTINGS MDE is indicated on the display.
- Step 2. Operate the Set Select UP or DOWN switch until TST MODE NO is displayed on the display.
- Step 3. Operate Status/EDIT Down switch while holding Status/EDIT Up switch.
- Step 4. Observe that LOAD DEF S? is displayed on the display.
- Step 5. Operate Reset switch and observe that LOADED DEFS is displayed on the display.
- Step 6. To save the settings, operate the Status/EDIT Up switch and observe SAVING SET is displayed on the display.

Loading factory default settings procedures is complete.

SECTION 6

MAINTENANCE

GENERAL

BE1-25/79TR Sync-Check Reclosing Relays require no preventive maintenance other than clock battery replacement (estimated 10 year life).

CAUTION

Always test the relay before placing it in operation.

CLOCK BATTERY

The clock battery has an estimated lifespan of 10 years. Replace the battery with Basler part number 26560. Consult the appropriate local agency or ordinance for proper disposal of spent batteries.

REPAIRS

In-house repair of the BE 1-25/79TR relay is not recommended. If the relay fails to function properly, contact Basler Electric.

STORAGE

This protective relay contains aluminum electrolytic capacitors which generally have a life expectancy in excess of 10 years at storage temperatures less than 40°C. Typically, the life expectancy of the capacitor is cut in half for every 10°C rise in temperature. Storage life can be extended if, at one-year intervals, power is applied to the relay for a period of thirty minutes.

SECTION 7

MANUAL CHANGE INFORMATION

SUMMARY AND CROSS REFERENCE GUIDE

This section contains information concerning the previous editions of the manual. The substantive changes to date are summarized in the Table 7-1.

Table 7-1. Changes

Revision	Summary of Changes	Date
A	Changed <i>Specifications</i> to reflect MOV installation and testing. Corrected the rated power supply voltage from plus or minus 12 Vdc to plus or minus 15 Vdc. Added cutout dimensions and drawings and information for the escutcheon plate. Added Section 7, Manual Change Information.	May 1995
B	Clarified the independent sync function throughout Section 1 and Section 3. Added start 52b and reclosing in progress functions -- appended <i>Specifications</i> , corrected <i>Factory Default Settings</i> , added <i>Selection Functions</i> , and updated Sections 1 and 3. Added complete description of front panel display features and the respective parameters to <i>Settings Mode</i> . Added Figure 3-2. Corrected Figure 1-2.	July 1995
C	Added caution statement about nonvolatile memory. Added voltage range for 48 Vdc control power. Clarified output contact ratings. Added information about clock battery. Added note about earth ground requirement.	August 2017



12570 State Route 143
Highland IL 62249-1074 USA
Tel: +1 618.654.2341
Fax: +1 618.654.2351
email: info@basler.com

No. 59 Heshun Road Loufeng District (N)
Suzhou Industrial Park
215122 Suzhou
P.R. CHINA
Tel: +86 512.8227.2888
Fax: +86 512.8227.2887
email: chinainfo@basler.com

111 North Bridge Road
15-06 Peninsula Plaza
Singapore 179098
Tel: +65 68.44.6445
Fax: +65 68.44.8902
email: singaporeinfo@basler.com