

INTRODUCTION

The APM 2000 Paralleling Module (part number 9147300100) is designed for use with the Basler APR63-5, APR125-5, and XR2002 voltage regulators. The APM 2000 is designed for the standard paralleling schemes, known as reactive droop compensation and reactive differential compensation. An externally connected unit/parallel mode switch (S1) prevents unwanted voltage droop caused by the regulator's working on the generator output and not on the bus load.

The APM 2000 operates in conjunction with an external parallel current transformer. The APM 2000 then provides the droop signal necessary to tow or more generators to share reactive loads and reduce circulating currents between them.

The voltage regulator and Paralleling Module must be connected into the generating system as shown in the interconnection diagrams.

ELECTRICAL SPECIFICATIONS

CT Input

Nominal Rating:	1 Aac or 5 Aac
Range	
1 A Input:	0.7 to 1.0 Aac
5 A Input:	3.5 to 5.0 Aac
Burden:	5 VA

Generator Voltage Drop

5% for 0.8 power factor load at 70% of nominal CT current rating

UL Recognition

Standard 508, file number E75380

CSA Recognition

Standard CAN/CSA-C22.2, number 14-M91, CSA file number LR23131

PHYSICAL SPECIFICATIONS

Temperature

Operating:	-55 to 70°C (-67 to 158°F)
Storage:	-65 to 85°C (-85 to 185°F)

Weight

590 g (1.3 lb)

INSTALLATION

Mounting

The rugged construction of the APM 2000 Paralleling Module permits mounting directly on the engine or genset. It can also be mounted directly on the switchgear or control panel. The APM 2000 may be mounted in any position without affecting its operation. For mounting, see Figure 1.

INTERCONNECTION

Current Sensing Input (Terminal C, 5A/1A)

Generator line current is sensed by either a 1 A or a 5 A (5 VA) secondary current transformer installed on the generator B-phase output lead. The CT secondary should deliver from 0.7 to 1 Aac for the 1 A tap or from 3.5 to 5 Aac for the 5 A tap when the generator is at rated load and power factor. The CT develops a voltage signal across adjustable resistor R1 in the Paralleling Module that is proportional in amplitude and phase to the generator line current. This voltage is applied to the voltage regulator sensing circuit. The result signal that is applied to the voltage regulator sensing circuit is the vector sum of the generator ac voltage and the voltage developed by the APM 2000.

Paralleling Signal Sensing Output (Terminals 6 and 7)

When a resistive load (at unity power factor) is applied to the generator, the voltage that appears across R1 (and transformer T1) leads the sensing voltage by 90 degrees. Since the vector sum of these two voltages is nearly the same as the original sensing voltage, almost no change will occur in the generator output voltage.

When an inductive load (lagging power factor) is applied to the generator, the voltage across R1 becomes more in-phase with the sensing voltage and the combined vectors of the two voltages result in a larger voltage being applied to the voltage regulator sensing circuit. Since the action of the regulator is to maintain a constant voltage at its sensing terminals, the voltage regulator reacts by decreasing generator voltage.

When a capacitive load (leading power factor) is applied to the generator, the voltage across R1 becomes out-of-phase with the sensing voltage and the combined vectors of the two voltages result in a smaller voltage being applied to the voltage regulator sensing circuit. Since the action of the regulator is to maintain a constant voltage at its sensing terminals, the voltage regulator reacts by increasing generator voltage.

PARALLEL COMPENSATION

When two generators are operating in parallel (Figures 2 and 3) the field excitation on one generator becomes excessive, causing a circulating current to flow between generators. The current appears as an inductive load to the generator (lagging power factor) with excessive field current and as a capacitive load to the other (leading power factor). The reactive droop compensation circuit in the APM 2000 will cause the voltage regulator to decrease its field excitation on the generator with the lagging power factor load in order to minimize the circulating currents between the generators.

This type of circuit is called reactive droop compensation. It allows two or more paralleled generators to proportionally share inductive loads by causing a decrease or droop in the generator system voltage.

Publication 9147300990	Revision H	Instructions	Date 09/12	Copyright 2012
----------------------------------	----------------------	---------------------	----------------------	--------------------------

The APM 2000 also provides the secondary circuit isolation for reactive differential compensation operation (Figures 4 and 5). Reactive differential compensation allows two or more paralleled generators in an isolated system to share inductive, reactive loads with no decrease or droop in the generator system output voltage. This is accomplished by the action and circuitry described previously for reactive droop compensation and by the cross connecting of the CT secondary leads. The figures show the finish of the first CT connected to the start of the second CT, etc. until all CTs are connected in series. The final step is to connect the finish of the last CT to the start of the first CT. This forms a closed, series loop that interconnects the CTs of all generators to be paralleled. The signals from the interconnected CTs cancel each other when the line currents are proportional and in-phase and no drop in system voltage occurs.

Reactive differential compensation can be used only if the regulators are identical and if the regulators on all the generators operating on a common bus are cross connected into the closed series loop. Generators of different kW ratings may be operated with reactive differential compensation if parallel CTs are selected that give approximately the same secondary current of each generator's rated load.

In reactive differential compensation applications of more than two generators, an external Unit-Parallel switch should be placed across terminals 1A and C and set to the Unit position when not operating on the load bus. If it is not, a voltage drop will be introduced into the system. This is because the unloaded generator parallel CT is not supplying its compensating signal, but allowing a voltage drop to occur across it. This drop will also cause the voltage of the incoming generator to fluctuate prior to paralleling. This fluctuation can be eliminated by utilizing an auxiliary contact on the main generator circuit as a Unit-Parallel switch. This auxiliary contact will be closed when the main generator circuit breaker closes. When this auxiliary contact is closed, the Unit-Parallel switch is not needed.

OPERATION

Before paralleling, the following test should be performed to confirm that the correct polarity and phase relationship exists between the voltage regulator, parallel current transformer, and paralleling module. Repeat this test for all systems that are to be paralleled.

If reactive differential compensation is used, the interconnection loop between the generators should be left open until completing these tests. (See Figures 4 and 5.)

Note

Meggers and high-potential test equipment should be used with extreme care. Incorrect use of such equipment could damage components contained in the device.

1. Adjust R1 (APM 2000) to the maximum resistance position (fully clockwise).
2. Set the Unit-Parallel switch to Unit or place a jumper across terminals C and 1A.
3. With the generator operating at rated speed and voltage, apply a lagging power factor load. (Unity power factor load cannot be used for this test.) Record the generator voltage.
4. With the load still applied, place the Unit-Parallel switch in the Parallel position and record the generator voltage.
5. Verify that the voltage obtained with the Unit-Parallel switch set to Parallel is less than the voltage obtained with the switch set to Unit.
6. If a higher voltage was obtained with the Unit-Parallel switch set to Parallel, stop the system and verify that the CT and sensing leads are connected to the correct generator lines. If all connections are proper and correct, interchange the parallel CT secondary leads.
7. If step 6 was required, repeat steps 1 through 4 to ensure that the system voltage droop is obtained.

Note

During single-unit operation, the Unit-Parallel switch shorts terminals C and 1A to prevent any droop signal from being injected into the regulating system. The system may be operated with the Unit-Parallel switch in the Parallel position if the voltage droop that results from the load is not objectionable.

REPLACEMENT PARTS

Table 1 lists the APM 2000 components and assemblies that have maintenance significance. When ordering parts from Basler Electric, specify the APM 2000 part number 9147300100, component reference designation, components part number, and component description.

Table 1. Replacement Parts

Ref. Des.	P/N	Qty.	Description
R1	14885	1	Resistor, variable, 6 Ω, 12.5 W
S1*	02660	1	Switch
T1	BE19289-001	1	Transformer

* Unit-Parallel switch S1 is not supplied with the APM 2000 and must be ordered separately.

Publication 9147300990	Revision H	<h1>Instructions</h1>	Date 09/12	Copyright 2012
----------------------------------	----------------------	-----------------------	----------------------	--------------------------

FIGURES

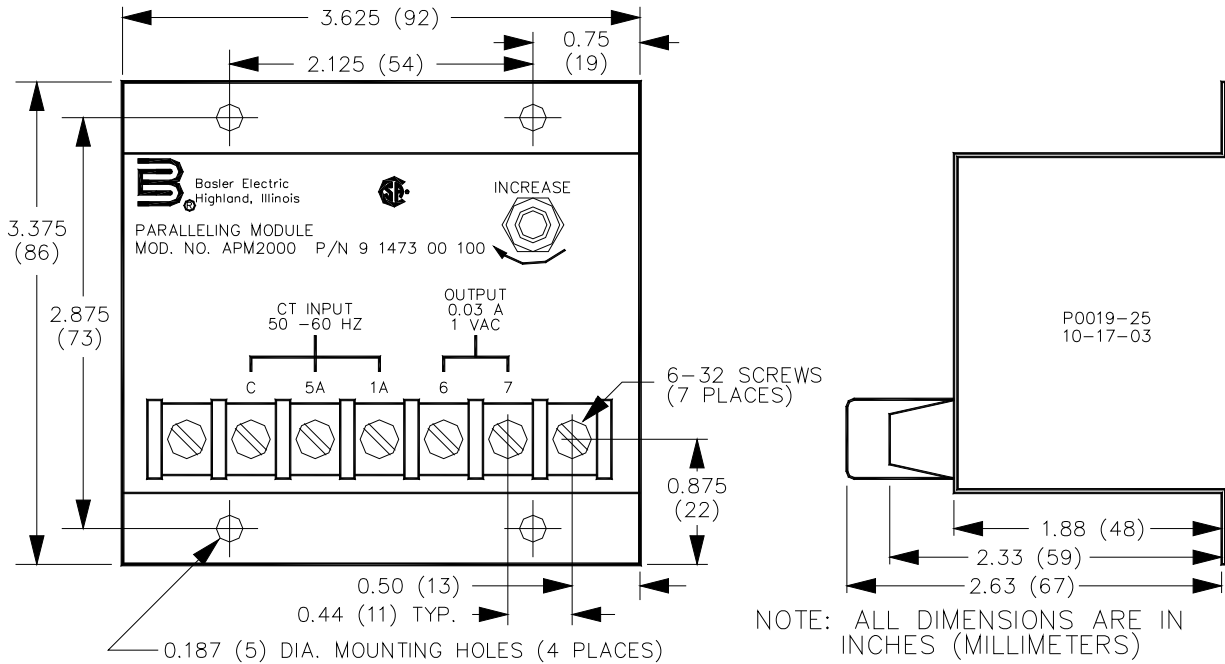
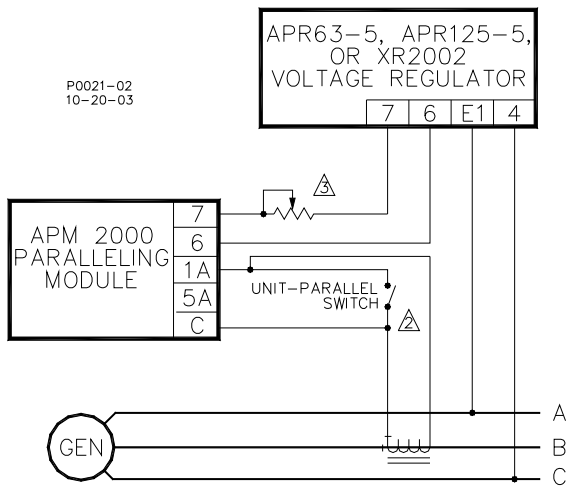

Figure 1. APM 2000 Mounting Dimensions



NOTES:

- 1. Generator phase rotation is ABC.
- ⚠ Open for parallel operation, closed for single-unit operation.
- ⚠ Voltage adjust rheostat supplied with regulator.
- ⚠ Terminal "4" for APR, terminal "E3" for XR2002.

Figure 2. Interconnection, 1 A Sensing

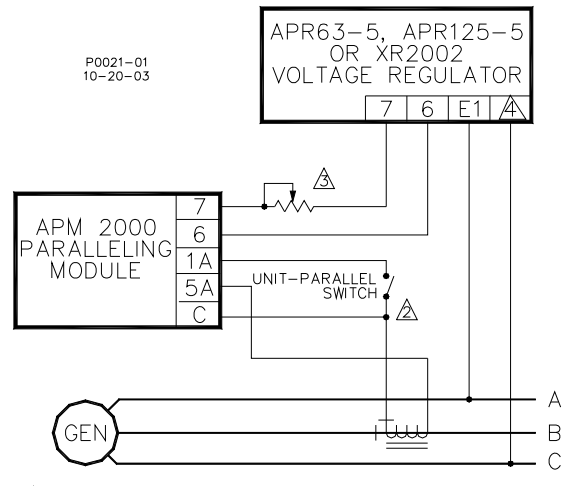

NOTES:

- 1. Generator phase rotation is ABC.
- ⚠ Open for parallel operation, closed for single-unit operation.
- ⚠ Voltage Adjust rheostat supplied with regulator.
- ⚠ Terminal "4" for APR 2000, terminal "E3" for XR 2002.

Figure 3. Interconnection, 5 A Sensing

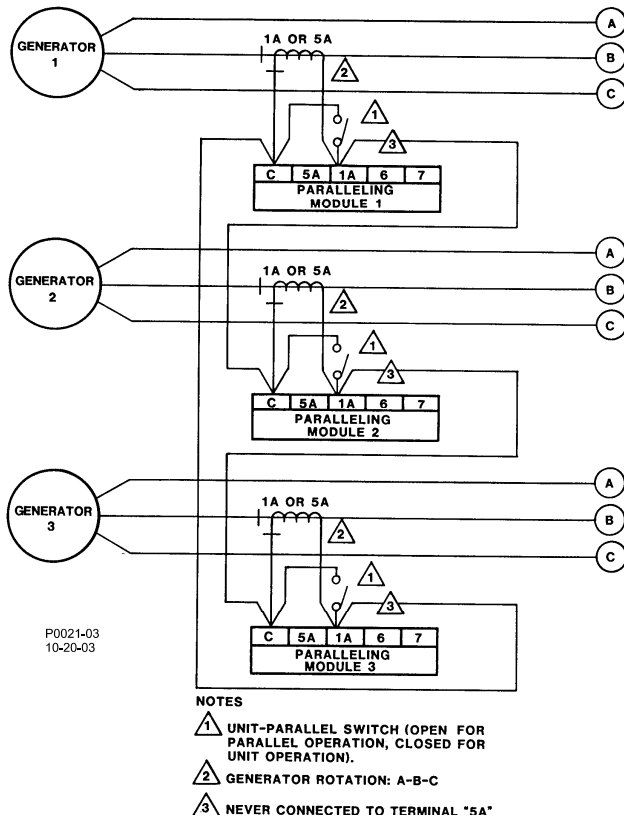

Figure 4. Reactive Differential Compensation, CT Interconnection, 1 A Sensing

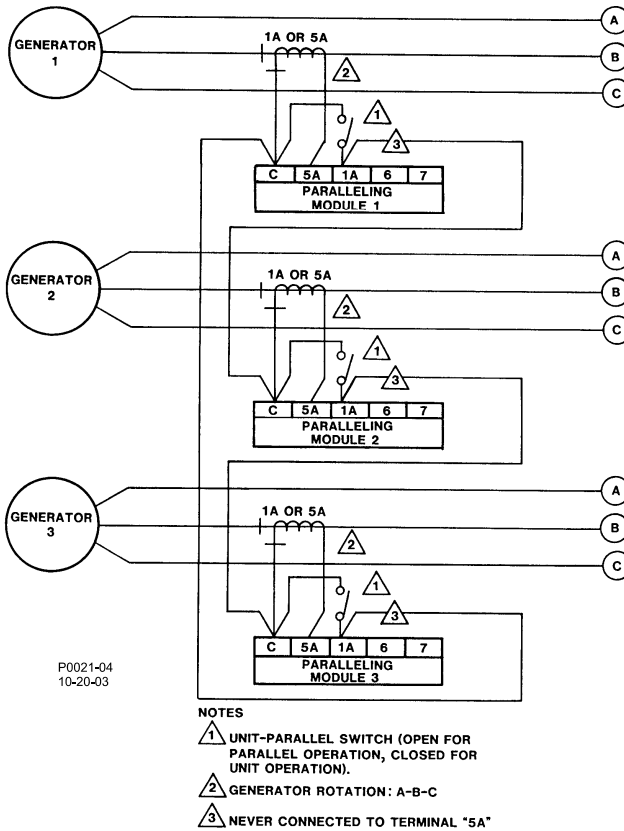

Figure 5. Reactive Differential Compensation, CT Interconnection, 5 A Sensing