

# Protection Considerations for Installation of Distributed Energy Resources

Gerald Johnson  
Basler Electric Company  
Highland, Illinois, USA

## I. General Information

Electric utility distribution systems must work with a variety of non-utility generation sources in today's political and policy-driven environment. Renewable sources such as photovoltaic and wind technologies have caused a dramatic increase in inverter-based systems. In addition, typical synchronous systems such as small hydro, diesel, methane, and natural-gas-powered generator systems are still being installed. Some wind-powered systems are connected at the distribution level, but most, based on economies of scale, have been connected to electric utility transmission systems. These generation sources, usually referred to as distributed energy resources (DER), have both positive and negative effects on the utility feeder. This publication addresses issues often encountered by utility engineers and DER consultants or developers when negotiating intertie protection requirements between the DER and electric utility. The subject matter is intended to be tutorial in nature. It is based on experience gained while working with customers to establish proper protection for given intertie applications as well as ongoing involvement with the IEEE working groups developing the 1547 series of standards.

### A. Frequently Used Terms

Frequently used terms found throughout this publication (defined below) are derived from *IEEE 1547-2003 (Reaffirmed 2008) Standard for Interconnecting Distributed Resources with Electric Power Systems* and others in the 1547 series, as well as the 2030 series of Smart Grid Standards.

- EPS - Electric Power System: Facilities that deliver electric power to a load

Copyright 2015 IEEE. Personal use of this material is permitted. However, permission to reprint/republish this material for advertising or promotional purposes or for creating new collective works for resale or redistribution to servers or lists, or to reuse any copyrighted component of this work in other works, must be obtained from the IEEE.

- Local EPS - Local Electric Power System: An EPS contained entirely within a single location or group of locations.
- Area EPS - Area Electric Power System: The facilities and equipment owned and operated by an electric distribution company and used to transmit electricity to ultimate usage points such as homes and industries.
- PCC - Point of Common Coupling: A circuit breaker between an area EPS and a DER that parallels the DER or Local EPS to the area EPS.
- Island - A condition in which a portion of an area EPS is energized solely by one or more Local EPSs through the associated PCCs while that portion of the area EPS is electrically separated from the rest of the area EPS.

### B. Introduction to DER

Parallel operation of DER at most utilities has become a part of their distribution operations program where the DER owner and the utility share a mutual interest in successful operation. The safety, security, protection, power quality, etc., are essential to proper operation on both sides of the intertie point.

A request from a developer for parallel operation of DER with most area EPS providers goes through a screening process and, depending on generator size, is reviewed by protective relaying engineers and possibly distribution planning engineers. Also, the majority of area EPS providers have procedures on their web sites explaining the process for those interested in parallel operation. Most area EPS procedures and requirements harmonize with IEEE 1547, but may not necessarily use the same sensitivities or time delays for over/undervoltage or over/underfrequency protection.

The safety of the area EPS personnel, who operate and maintain the distribution system, is

first and foremost. If an unknown source of DER is connected to a circuit or the interconnected facility is not following operating practices agreed to in their contract, an area EPS lineman may come in contact with energized conductors. The safety of the area EPS personnel is ultimately the responsibility of the area EPS provider. This should be reflected in negotiations with the DER owner or developer. The challenges posed by parallel generation do not diminish significantly with reduction in generator size.

For more details, consult *IEEE 1547.2-2008 IEEE Application Guide for IEEE Std 1547™*, *IEEE Standard for Interconnecting Distributed Resources with Electric Power Systems*, and *IEEE 1547.7-2013 Guide to Conducting Distribution Impact Studies for Distributed Resource Interconnection*.

### C. Types of DER

Three types of DER, described in the following paragraphs, are peak shaving, net energy metering, and export energy.

Peak shaving is a method of reducing the purchased power by adding a DER at a facility to shave or reduce the load demand seen by the area EPS during peaks. Typically the area EPS requires a reverse power relay (32) at the intertie point to prevent any power flow from the DER into the area EPS.

With net energy metering at the intertie point, the area EPS can monitor energy flow into or out of a facility. The customer is either billed or reimbursed by the area EPS based on the net power consumed or produced over a given period of time. Net metering is used in single-phase residential photovoltaic installations as well as larger three-phase facilities that have a net energy metering agreement.

An Export Energy DER requires a sales agreement between the area EPS and the DER based on the EPS tariff provisions. The area EPS contracts with the DER or local EPS to purchase energy.

### D. Radial Distribution Feeder

DERs are applied to distribution systems. The majority are connected to radial distribution lines or feeders, although many of the protection principles can be carried over to loop systems as well.

AC power systems are configured for many different voltage levels with no international standards. While voltage levels may vary, the levels considered in this publication fall into the distribution category. Typical voltage classifications are as follows:

- Distribution: 34.5 kV and lower
- Sub transmission: 34.5 to 138 kV
- Transmission: 115 kV and higher

The Transmission category can also be subdivided into the levels shown below:

- High Voltage (HV): 115 to 230 kV
- Extra-high Voltage (EHV): 345 to 765 kV
- Ultra-high Voltage (UHV): 1000 kV and higher

Power lines can also be classified as either radial (feeders) or as loop lines.

Radial lines, or feeders, have a positive-sequence source at only one terminal. Induction motors are not generally considered to be sources. Typical feeders are distribution lines supplying power to non-synchronous loads. Thus, for line faults, current is from the source end only. For ground faults on the line, current can flow from both ends if they are both grounded. Tripping the positive-sequence source de-energizes the fault. However, if there is zero-sequence mutual coupling from adjacent lines, the ground sources must also be tripped to clear the fault.

Loop lines have positive-sequence sources from two or more terminals. These are generally transmission lines, but may include distribution lines. Fault current contribution is from all sources, thus all sources must be tripped to clear both line and ground faults.

### E. Types of Generation

A generator's rotation speed is controlled to match the utility's frequency of 60 Hz. The prime mover (steam turbine, diesel engine, gas turbine, or hydro) supplies the mechanical power to keep the generator moving. Synchronous machines have excitation systems and are capable of supplying load as an independent source with voltage and frequency control. Induction machines get their excitation from the system and generally cannot operate independent of the area EPS. Some induction generator installations utilize switched capacitor banks for voltage and var support. Induction

generators with switched capacitor banks may need to be treated and relayed as a synchronous generator. Either type of generator may be single-phase or three-phase.

Power inverters change dc to ac electronically. The dc source could be batteries, dc generators rotated by wind farms or other prime movers, fuel cells, or photovoltaic panels. Line commutated inverters need an external source of reactive power to operate and normally shut down when the utility tie opens. Self-commutated inverters can continue to supply power independently and do not require a source from the utility. These inverters should be tripped when the utility tie opens.

The most substantial growth in DER is related to new technology in inverter-based photovoltaic systems. Many thousands of single-phase and three-phase systems are being installed across the US with no end in sight. This is the prevalent form of green power today and for the near future. Inverter technology continues to push the envelope as related to voltage regulation and islanding protection, while providing megawatts of power as long as the sun shines. To take full advantage of the real benefits of solar technology, small, cost effective, reliable, battery storage systems must become a reality.

Power converters change non-60 Hz generation into 60 Hz power. The ac source could be micro-turbines generating 400 Hz. These static power converters can synchronize to the 60 Hz utility system faster than a synchronous generator where the excitation must be controlled to match voltage and frequency of the utility. Static power converters are also known as isochronous generators.

## F. Types of Generator Connection

When generators are relatively large (greater than 10 MVA) they are typically connected to the utility transmission system at 69 kV or above as shown in Figure 1. These installations cannot be placed on the distribution system because the distribution line may not be able to handle current capacity required to support 10 MVA.

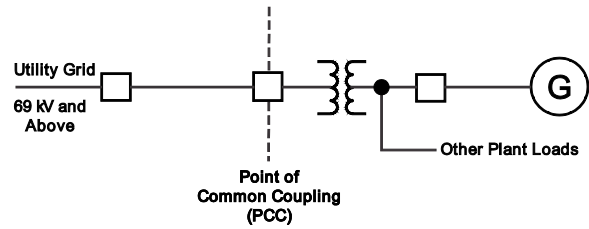

Figure 1: Large Generator - Transmission Tie

These transmission-type interconnections are common on industrial systems where steam is used as part of the process and excess steam is used for power generation. Excess generation can be sold back to the utility if the contract with the utility allows it. Because of the size of these units and their connection to the transmission grid, they are normally operated as if they were part of the utility grid. The utility system dispatcher talks directly to the plant operator with respect to generator loading.

Protective relays are selected as if this were a utility generator connected to the transmission grid. It is normal for a full complement of relays to protect the generator and the transmission grid. Settings are closely coordinated with the utility.

Installations of this type are not covered in the Intertie Standard, IEEE 1547-2003.

Smaller generators can be connected to the utility distribution system at 7 to 13 kV as shown in Figure 2 or as high as 34.5 kV depending on the area EPS distribution voltage level. These lines can handle the load of smaller generators so distribution lines are run to commercial and residential customers, making the connection more convenient. Distribution lines are typically radial, which means they have a source at one end only. If the utility breaker opens, the whole line is de-energized. The lines in a transmission system are normally networked, providing source from both ends of the line. As demand for more renewable energy has grown, demand for inverter-based photovoltaics has grown as well. As mentioned earlier, the traditional definitions of distribution and transmission, especially related to operation, are changing to accommodate the mandated increases in renewables.

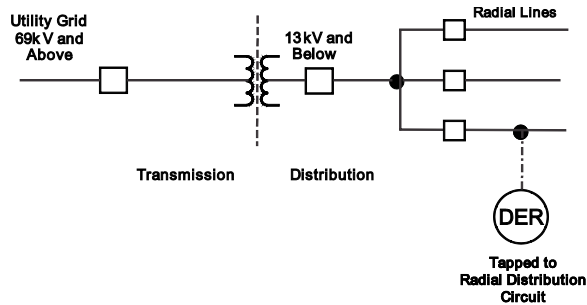

Figure 2: Small Generator - Distribution Tie

## II. Requirements

### A. IEEE Standard 1547-2003 for Interconnecting Distributed Resources with Electric Power Systems

The following resources are provided as a guide for proper protection of a DER interconnected to the utility.

*Subjects included in IEEE 1547-2003:*

- DER shall cease to energize the utility for faults on the utility.
- If stiffness ratio is 10 or less, DER shall have suitable fault protection.
  - Phase - 51/27C, 51/27R, 67, or 21
  - Ground (grounded systems) - 67N or 51N
  - Ground (ungrounded systems) - 59N
- If the DER and utility feeder become islanded unintentionally, the DER shall cease to energize the feeder within two seconds.
  - DER capacity of less than one third minimum feeder load
  - Reverse power relay (32) trips DER at PCC
  - Over/undervoltage and/or over/underfrequency trips the DER
  - Transfer trip
- Additional requirements
  - Synchronizing
  - Power Quality
  - Testing
  - Commissioning

*Subjects not included in IEEE 1547-2003:*

- How the inertia should be operated
- How to protect the generator

- Capacity greater than 10 MVA
- Closed transitions of less than 100 ms

### B. Evolving 1547 Standards

The area EPS is obligated to connect a DER if it meets the area EPS guidelines. Safety, security, protection, power quality, continuity of service, etc. are the responsibility of the area EPS and are factors in the screening process of DER applicants. In some parts of the US, there are state mandated requirements to have at least 33% of generation assets from renewable power. A large portion of this is from photovoltaic sources on the distribution system. This mandate places a lot of pressure on the screening processes, the personnel responsible for approving these projects, and the standards used to implement these projects.

As an example, one area EPS provider has 22 kV distribution circuits with 15 MW of solar generation connected. The 22 kV feeder is being operated as a transmission line. As such, any unwanted trip results in the loss of 15 MW that has to be immediately replaced. Following the existing IEEE1547-2003 standard, voltage dips caused by remote faults and frequency variations during fault clearing could result in many misoperations. In a growing number of installations, it was becoming obvious that changes had to be made to the existing IEEE 1547-2003 standard.

In the original 2003 standard, there is no accommodation for the DER to actively regulate voltage at the PCC. Subsequent amendments allow the DER to actively regulate voltage at the PCC based on specific coordination and approvals between the DER and EPS operators.

The voltage and frequency windows of operation in the original standard were not designed to accommodate ride-through for transient voltage and frequency conditions. Tables 1 and 2 of the original standard that defined default trip thresholds and time delays were amended to include not only default clearing time, but also adjustable clearing time. Under mutual agreement between the EPS and DER operators, other static or dynamic voltage, frequency, and clearing time trip settings shall be permitted. Clearing time is the time between the start of the abnormal condition and the DER ceasing to energize the area EPS.

After much input from the industry in regards to voltage regulation, specifically targeting sensitivity and time delays for over/undervoltage and over/underfrequency tripping, a working group in SCC21 was formed to amend IEEE 1547-2003. The result was IEEE 1547a-2014 which was approved in 2014 and includes amendments to change the voltage and frequency ride-through (sensitivity and time delay) and changes to voltage regulation. Also added to the amendment, is the flexibility to go beyond the recommended settings for voltage and frequency under mutual agreement between the EPS and DER operators.

With var capability from inverters associated with photovoltaic systems, the area EPS can provide voltage support. *IEEE 1547a-2014, IEEE Standard for Interconnecting Distributed Resources with Electric Power Systems Amendment 1* includes changes that allow voltage regulation by the DER under mutual agreement between the area EPS and DER operators.

As a result of IEEE 1547a Amendment 1, *IEEE Standard 1547.1 Standard Conformance Test Procedures for Equipment Interconnecting Distributed Resources with Electric Power Systems* had to be amended. P1547.1a is in the balloting process at the time of this writing and adds test procedures to prove conformance to the changes included in IEEE 1547a Amendment 1.

Additionally, it was approved in 2014 to open the original IEEE 1547-2003 document as P1547 and is in the process of full review which will likely include 1547a Amendment 1. For those regularly involved in interconnection of DER, review of the amendments and document changes is strongly recommended. Progress, meeting schedules, and locations are posted on <http://grouper.ieee.org/groups/scc21/>.

### C. Typical Area EPS Feeder Operations

Utility feeders have always been designed as radial circuits with the only source being the substation breaker. When a DER is added, it becomes a potential source of power that was never intended for radial operation, which creates challenges for protection philosophy and coordination.

The area EPS must answer to its local regulatory agency or public service commission by maintaining voltage to approximately  $\pm 10\%$ ,

maintaining frequency to approximately  $\pm 0.1$  Hz, limit voltage dips, sags, swells, flicker, and harmonics, and minimize interference with communications equipment.

The utility must detect and remove faults promptly to minimize damage to equipment and voltage distortions. Outage times must be minimized by reclosing the feeder breaker after the fault is cleared, which takes place as fast as one third of a second. The DER must be clear of the line when the utility recloses or damage to the DER may result.

The utility must provide a safe, de-energized condition when dead line work is done or when a line is on the ground. Since every DER is a potential source of power that could re-energize the line, safety concerns must be addressed by the utility and DER owner.

### D. Reconnection of DER to Area EPS

After an area EPS disturbance, no DER reconnection may take place until the utility voltage is within Range B of ANSI C84.1-2011, and frequency is within the range of 59.3 Hz to 60.5 Hz. The DER interconnection system shall include an adjustable delay of up to five minutes or a fixed delay of five minutes after the area EPS steady state voltage and frequency are restored to the ranges listed in Range B of ANSI C84.1-2011.

### E. Other Protection Requirements

Intertie applications cover only the requirements to protect the PCC. However, there may be transformers and generators with protection requirements as well. The functions needed to protect those components are listed below according to *IEEE C37.2-2008 IEEE Standard for Electrical Power System Device Function Numbers, Acronyms, and Contact Designations*.

These are the device codes used in most protection diagrams:

- 21 - Impedance-based distance
- 24 - Generator or transformer overexcitation
- 25 - Synchronism check
- 25A - Automatic synchronizer
- 27 - Undervoltage
- 32 - Reverse power or overpower
- 40Q - Loss of excitation
- 46 - Current unbalance
- 47 - Voltage unbalance

- 50 - Instantaneous overcurrent
- 51 - Inverse time overcurrent
- 51/27C - Voltage control overcurrent
- 51/27R - Voltage restraint overcurrent
- 59N - Neutral overvoltage
- 59 - Overvoltage
- 60 - Voltage balance
- 78 - Out of step
- 81 - Over/underfrequency
- 87 - Differential

### III. General Protection

#### A. General Protection Requirements-Connecting DER to the Area EPS

A typical DER connection to a radial distribution feeder is shown in Figure 3.

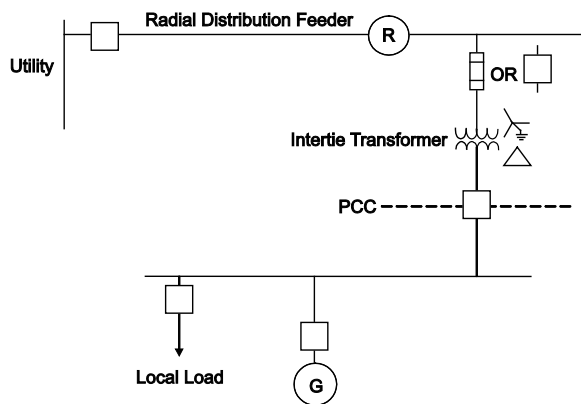

Figure 3: Typical DER Connection to Radial Distribution Feeder

DER protection requirements vary depending on the size and type of DER and area EPS protection requirements. Intertie protection prevents the utility system and connected generators from damaging each other. Protection is normally applied at the interconnection point. Some techniques for intertie protection are as described below.

**Phase and ground fault protection** – Protective devices are required for detecting faults in the DER and possibly the distribution feeder. The DER should coordinate with relays on the distribution feeder.

**Overvoltage (59) and undervoltage (27)** – The DER must operate within established distribution levels. Relays must isolate the DER when the voltage is outside these levels. Undervoltage relays are generally time delayed to prevent

unnecessary tripping of the DER from external faults. The delay time is a function of the difference between measured voltage and nominal voltage. Faster clearing times are required as the voltage level diverges from the nominal level. These levels and clearing times are defined in the applicable standards. Inverse time undervoltage relays or relays with multiple undervoltage elements can be used. Instantaneous overvoltage relays are acceptable. See Table 1 in IEEE 1547a for details.

**Overfrequency and underfrequency (81O/U)** – Over and underfrequency relays are applied to separate the DER from the utility system for frequency levels outside of prescribed limits. These relays are time delayed. The length of the time delay depends on the difference between the detected frequency or rate-of-change-of-frequency and the nominal level. See Table 2 from IEEE 1547a for reference.

**Anti-islanding** – Anti-islanding protection is used to prevent the DER from being connected to a de-energized utility feeder. If the DER is not removed from the system, the DER may be unable to maintain the required power quality to the power system customers. Over/undervoltage (59/27) and over/underfrequency (81O/U) relays provide basic anti-islanding protection. Where the DER rating closely matches the distribution load, there may not be sufficient change in the voltage or frequency for these relays to operate. In this case, pilot tripping (transfer trip) may be necessary to ensure the DER is prevented from islanding.

**Directional overcurrent (67)** – Directional overcurrent relays may be required to detect faults in the interconnection transformer or on the utility distribution line.

**Directional power (32)** – Directional power relays may be required for anti-islanding. Where power export is not allowed, the directional power may be set to look either forward or reverse. When set to detect power export (reverse power), the relay may be set to trip at any reverse power level above zero. When set to detect power import (forward power), the relay may be set to trip at a level below the minimum expected power import level.

**Special interconnection protection** – If the DER is large enough to affect the stability of the power system, out-of-step (78) or loss of synchronism protection may be required.

Inadvertent energization of utility system by DER – The DER should not be able to energize a dead utility system. When connecting to a live utility system, the DER must properly synchronize to the utility to ensure the DER will not be damaged. A synchronism check relay (25) or, depending on generator size, an automatic synchronizer (25A) is used to ensure proper connection to a live utility system.

### B. Intertie Protection for Small DERs

The determination of small DERs may vary depending on the particular system to which it is attached. For the purpose of this discussion, it is assumed that a small DER will not export power and, if islanded, will not be able to support the minimum utility feeder load. Therefore, overvoltage (59), undervoltage (27), vector jump (78V), overfrequency (81O), underfrequency (81U), and rate of change of frequency (81 ROCOF) elements may be sufficient to trip for a fault or island condition. A generator is typically determined to be small based on the DER to minimum circuit load ratio. Over and undervoltage relays and over and underfrequency relays are set to respond to abnormal voltages and frequencies with clearing times determined by the applicable standards (e.g. IEEE standard 1547a). Table 1 shows an example of a typical requirement for response to abnormal voltages.

Table 1—Interconnection system default response to abnormal voltages

Default settings <sup>a</sup>		
Voltage range (% of base voltage <sup>b</sup> )	Clearing time (s)	Clearing time: adjustable up to and including (s)
$V < 45$	0.16	0.16
$45 \leq V < 60$	1	11
$60 \leq V < 88$	2	21
$110 \leq V < 120$	1	13
$V \geq 120$	0.16	0.16

<sup>a</sup> Under mutual agreement between the EPS and DR operators, other static or dynamic voltage and clearing time trip settings shall be permitted.  
<sup>b</sup> Base voltages are the nominal system voltages stated in ANSI C84.1-2011, Table 1.

Figure 4 shows basic intertie protection for a small DER. In the case of loss of the utility, the intertie protection must separate the DER from the system within two seconds or prior to any area EPS reclose. This will ensure the DER is not energized from the utility in an out-of-synchronism condition.

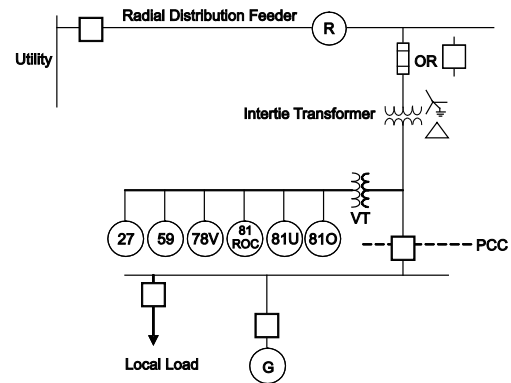

Figure 4: Basic Intertie Protection for Small DERs

### C. Intertie Protection for Medium to Large DERs

Large DERs employ the same relays as small DERs. In addition, these large DER facilities may require protection to isolate the DER for faults occurring either in the DER itself or on the distribution system. DER protective devices are generally required to coordinate with protective relays on the distribution system, unless otherwise agreed.

Non-directional overcurrent relays (51) are generally used on the low side of the interconnecting transformer to detect bus and feeder faults at the customer facility.

With generation added to the customer facility, the non-directional overcurrent protection will still detect these bus and feeder faults. However, they may not be sensitive enough to detect the DER's current contribution to faults in the interconnecting transformer or on the utility distribution line. Directional overcurrent protection (67) should be set to detect faults on the high side of the interconnecting transformer and out onto the utility feeder.

Directional power relays (32) may be added for anti-islanding protection. One way to do this is by detecting power export (reverse power flow toward the utility) and setting the relay to trip for power flow less than a minimum load level that may be on the utility feeder.

A directional power relay may also be used to detect power import (forward power flow toward the DER). Set the relay to trip for power flow less than a minimum power import level.

Phase current imbalance protection (46) and phase voltage imbalance detection (47) may

also be added if the sensitivity of over and undervoltage (59/27) elements is not sufficient to trip the intertie breaker. This prevents equipment damage due to negative sequence voltages or currents.

Directional negative sequence overcurrent (67Q) relays or voltage controlled overcurrent relays (51V) may also be used to provide increased sensitivity for imbalance faults on the utility feeder.

Figure 5 illustrates basic intertie protection for medium-sized DERs.

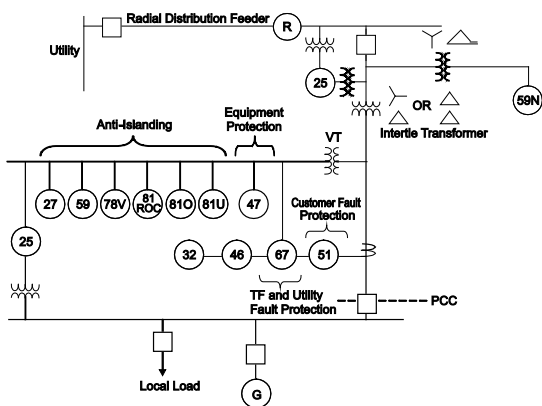

Figure 5: Basic Intertie Protection for Medium-Sized DERs

#### D. Automatic Transfer Schemes

Typically, if the area EPS source is lost, the facility (Data Center, Hospital, Banking Institutions, Food Market Chains, etc.) detects the loss of source and starts an emergency generator to restore power to critical loads. When the area EPS source is restored, and a predetermined amount of time has passed insuring the area EPS source is stable, a closed transition is initiated. A closed transition is a momentary paralleling of the facility generator with the area EPS. A closed transition time of 6 cycles (100 ms) or less is not considered a parallel condition and therefore is not covered by IEEE 1547-2003. However, it is listed under 1.3, Limitations, in the standard as follows: “This standard does not apply to automatic transfer schemes in which load is transferred between the DER and the EPS in a momentary make-before-break operation provided the duration of paralleling the sources is less than 100 ms, except as noted in 4.1.4.”

Depending on the size of the generator, some area EPS providers may require reverse power protection (32) in the event transfer does not occur in 6 cycles (100 ms).

#### E. DER on Spot and Grid Networks

Small parallel distributed generation connected to a secondary distribution network generally requires study to ensure the DER does not degrade the reliability, power quality, safety, or operation of the network system. Typically an intertie relay is required at the PCC to provide basic intertie protection such as over and undervoltage (59/27), over and underfrequency (81O/U), and phase imbalance protection (47). A circuit breaker with a 2.2 PU voltage rating shall be installed for disconnecting the generator during faults or abnormal conditions.

#### F. Synchronizing

Synchronizing is the act of matching, within allowable limits, the voltage magnitude, phase angle, and frequency of a DER with an area EPS prior to closing the DER breaker. Closely matching these three values prior to closing the paralleling breaker minimizes transients caused by bringing the DER generator on line. Phase rotation is usually checked during installation of the generator and breaker and, presumably, remains that way. However, in the case of portable generation, it becomes necessary to verify proper phase rotation before closing the breaker. This is accomplished with a negative sequence voltage (47) relay in series with the synch check (25) relay.

##### Typical Synchronizing Requirements

The following resources are provided to aid in proper synchronizing of a DER to the utility.

- IEEE Std. 1547.2-2008 IEEE Application Guide for IEEE Std 1547 IEEE Standard for Interconnecting Distributed Resources With Electric Power Systems page 110
- Synchronizing (IEEE Std 1547-2003 4.1.3)
- “Get in Step with Synchronizing”, Basler Electric
- “Generator Protection Application Guide”, August 2014, Basler Electric

The DER shall parallel with the utility without causing a voltage fluctuation at the PCC greater

than  $\pm 5\%$  of the prevailing voltage level of the utility at the PCC. It shall meet the flicker requirements of IEEE Std 1547-2003 4.3.2

## IV. Challenges and Solutions

### A. Islanding

Adding DER to utility feeder lines creates several challenges. If the DER is small and the utility feeder breaker trips, the voltage and frequency of the utility feeder will decline and the DER can be easily tripped off line with local intertie protection. There doesn't have to be a fault on the feeder for this to happen; it could be a bus fault, load shedding operation, or operator error at the utility substation. The problem occurs when the minimum feeder load is equal to or less than the total DER output which allows the DER to carry the load without the utility. This is called unwanted islanding and must be avoided.

Islanding is possible with one or more generators, given that the total DER is about equal to the load. Power quality (voltage, frequency, and harmonics) may not be maintained by the islanded generators within the levels required by the utility's regulating body. As a result, if damage occurs to area EPS customer's equipment, the area EPS is held responsible.

Automatic reclosing is used to restore power to customers after a feeder breaker trips at the utility substation. Reclosing on an islanded synchronous generator may cause damage to the generator. Having islanded synchronous generators requires synchronizing to reconnect the generator, load, and the utility. Closing the feeder breaker requires monitoring the phase angle and voltage across the intertie breaker. An automatic synchronizer (25A) must be able to control voltage and frequency of the DER. Reclosing on an inverter-based DER or induction-based DER island will not cause damage, but unwanted islanding must be avoided.

As shown in Figure 6, islanding protection usually consists of over/undervoltage (59/27), over/underfrequency (81O/U), and reverse power (32) relays. When the utility breaker opens, voltage and frequency decreases if generation is less than load or increases if generation is greater than load. The over/undervoltage and over/underfrequency

relays detect the event and trip the PCC, preventing an island condition. Also, the intertie breaker is tripped if a sudden change in magnitude and direction of power occurs, preventing an unwanted island condition.

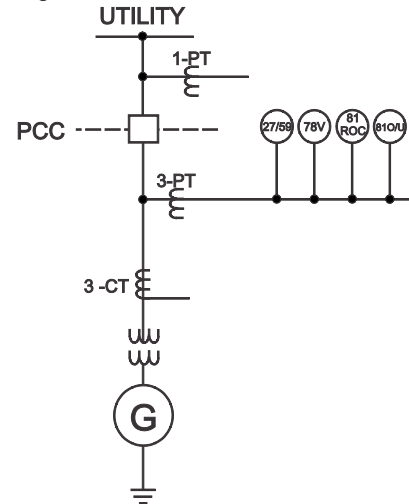

Figure 6: Islanding Protection

Another possible solution to islanding is shown in Figure 7. When the feeder breaker opens, transfer trip can be used to send a signal to the DER to trip the tie breaker. Equipment cost is high and dedicated communication channels are required for transfer trip configurations. One major disadvantage for the utility is that the ability to reconfigure the feeder is lost. Utilities often transfer loads from one feeder to the next to balance loads or while work is being done on a breaker in the substation. If this is the case, the transfer trip needs to be reconfigured to another feeder each time, which is not practical. If the DER is located adjacent to the utility substation, a direct trip can be sent to the DER with a contact over metallic cable, if the voltage drops are not excessive. Many other technologies that make direct transfer trip impractical are being used. These include broadband radio, high frequency radio, cell service, and possibly synchrophasors. There are also methods for applying three-phase faults to the system *after* the substation breaker opens, forcing the intertie protection (67 or 21) to trip the intertie breakers.

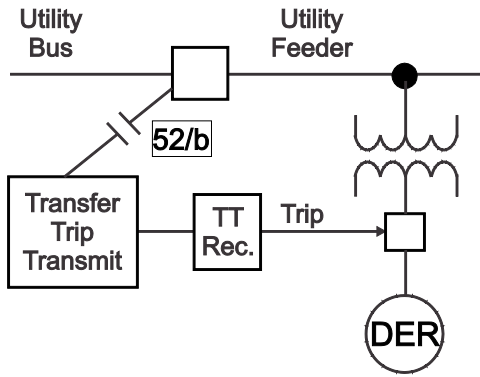

Figure 7: Complications - Transfer Trip

There are cases where intentional islands are beneficial, but a formal agreement between the area EPS operator and the DER or local EPS must be established. For more information on intentional islands, consult *IEEE Standard 1547.4-2011 Guide for Design, Operation, and Integration of Distributed Resource Island Systems with Electric Power Systems*.

Synchronism check (25) is required to prevent the DER from connecting to the power system out-of-synch. It may be applied at the primary-side transformer breaker, the secondary-side transformer breaker, or both.

## B. Fault Current

The vast majority of utility feeders have been designed as four-wire radial systems with one source at the utility breaker. Relay systems have been designed and coordinated around these principles.

When DER is added to the feeder in one or more locations, the DER can supply part of the fault current as shown in Figure 8. It can either change the relay coordination at the substation or cause additional fault current to appear at the fault. As the size of the DER increases, so does the likelihood of problems.

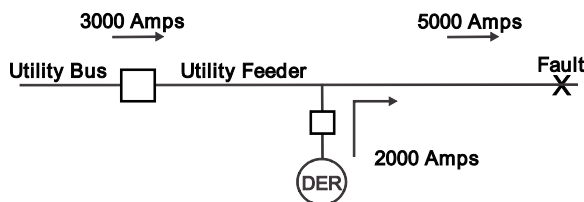

Figure 8: Complications - Fault Current

Another potential problem (Figure 9) is an uncleared external fault. Ideally, a fault on the

feeder is sensed by the relay back at the utility substation and the utility breaker is tripped. Then, the generator breaker is tripped by over/underfrequency (81O/U) and/or over/undervoltage (59/27) relays for anti-islanding protection.

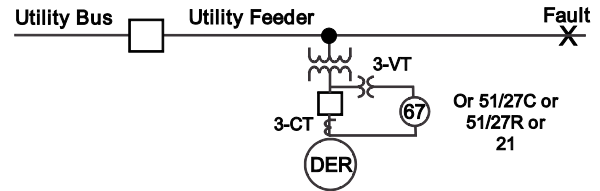

Figure 9: Complications - Fault Current

If, for some reason, the fault is not cleared in the normal manner, the intertie protection at the PCC should sense the un-cleared external fault and trip the PCC.

This can be done with the following protection elements:

- 51 – time overcurrent
- 67 – directional overcurrent
- 51/27C – Voltage controlled overcurrent
- 51/27R – Voltage restraint overcurrent
- 21 – Distance

## C. Transformer Connection

Almost every installation has an intertie transformer to match the voltage between the DER and the utility. The transformer connection can be wye, grounded wye, or delta on primary or secondary windings. There is no perfect combination that yields the best situation for all parties; they all have drawbacks.

Most utility feeders are three-phase, four-wire, multi-grounded systems. The transformer at the utility bus has a solidly grounded neutral and all distribution transformers on the feeder have a grounded neutral. Three-phase loads are connected either phase-phase or phase-neutral. Single-phase loads are connected phase-neutral.

As shown in Figure 10, the primary winding of the DER transformer is ungrounded (delta or ungrounded wye primary). When a fault occurs on the feeder and the utility breaker trips to clear the fault, the ground source (which is the substation transformer at the utility substation) is disconnected. If the DER stays on, the ground fault will not be detected because the feeder is

now ungrounded and the healthy phases could see as much as 173% overvoltage.

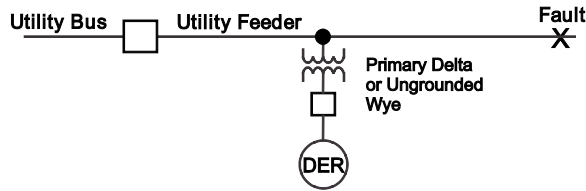

Figure 10: Complications – Ungrounded Primary

Figure 11 shows the normal phasors for a three-phase, four-wire, grounded feeder. Single-phase loads are connected phase-neutral while three-phase loads are connected phase-phase or phase-ground. During an A-phase fault, the  $V_{ag}$  collapses but  $V_{bg}$  and  $V_{cg}$  are near normal. Connected loads either receive low voltage or normal voltage. When the substation breaker trips, the voltage goes to zero and the connected loads never receive overvoltage.

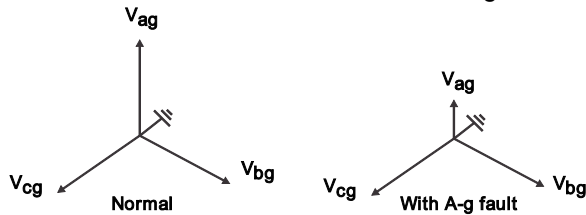

Figure 11: Phasors without Islanded DER

The phasor diagrams, shown in Figure 12, reflect the ground voltages present when a DER is islanded from the utility. If the utility breaker opens and an ungrounded DER stays on, the normally grounded feeder neutral becomes ungrounded. The phasors retain their normal symmetry but are displaced to ground level. A fault from A-ground now causes A-ground loads to drop to nearly zero volts and B-neutral or C-neutral connected loads to jump as high as 173% of normal voltage.

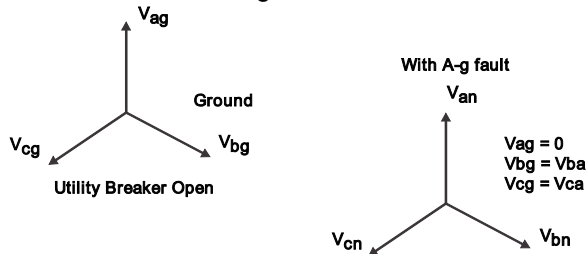

Figure 12: DG Islanded with Ungrounded Primary

Once the utility breaker is open, the utility customer's equipment will be damaged by the

high voltage. Therefore, a relay should be placed on the intertie to protect against this condition.

One solution is to monitor the broken delta voltage on the primary winding of the transformer, shown in Figure 13. This requires three, three-phase PTs wired in broken delta to measure the  $3V_0$ . A resistor is added across the output to prevent ferroresonance. The 59N coil (neutral overvoltage) monitors the broken delta voltage ( $3V_0$ ). When voltage is normal on the feeder, the  $3V_0$  voltage across the 59N relay is very low.

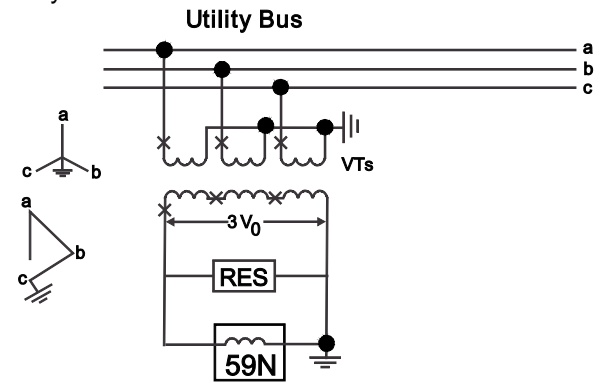

Figure 13: 59N for Ungrounded Primary

When a phase-ground fault occurs, the faulted phase voltage collapses, and the  $3V_0$  voltage across the 59N increases to as high as full secondary phase-ground voltage.

With proper programming, a multifunction relay with a four-wire connection calculates the  $3V_0$ , operates a 59N element, and trips the intertie breaker. This eliminates the need for the external broken delta transformer.

In Figure 14, the intertie transformer has a grounded primary which causes it to supply a portion of the ground fault current, much like a grounding transformer.

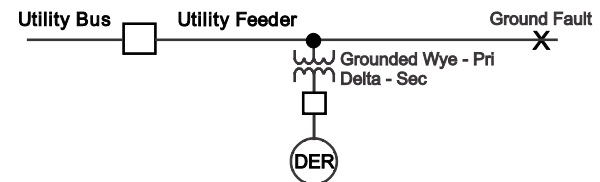

Figure 14: Complications - Grounded Primary

With the DER breaker open, if the intertie transformer is still connected to the feeder, it can supply ground current with zero sequence

currents circulating in the delta secondary winding.

If the intertie transformer is grounded on the utility side, ground current can be supplied to a fault on the distribution feeder by the intertie transformer. Utility feeder phase fault protection at the intertie is provided by instantaneous and time overcurrent relays (50/51) on the primary winding of the intertie transformer. Ground fault protection at the intertie is provided by a time overcurrent relay (51N) in the neutral of the intertie transformer.

The ground source provided by the intertie transformer may cause undesirable relay operation at the utility substation breaker (B) or at the recloser (R) on the feeder from faults on the distribution feeder or adjacent feeders. Directional overcurrent relays may be applied to the utility feeder breakers to ensure proper relay operation for faults on the feeder. Figure 15 shows interconnection protection for a DER connected through a transformer with the primary winding grounded. The current reversal is shown for faults on the utility feeder and for ground faults on adjacent feeders.

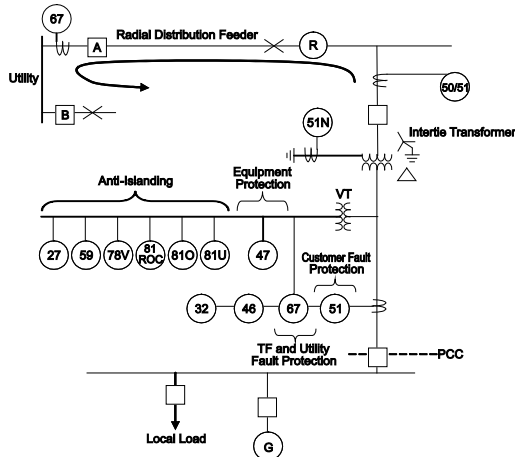

Figure 15: Basic Intertie Protection for Medium-Sized DERs. Transformer Primary Grounded

Unbalanced loads are common on utility feeders, especially during switching and operation of lateral fuses and reclosers. With a grounded intertie transformer, the neutral current that would normally return to the neutral bushing of the substation transformer is instead split with the intertie transformer. The circulating current in the delta winding of the intertie transformer can reduce its load-carrying capacity.

If the primary and secondary windings of the intertie transformer are grounded, as shown in Figure 16, the utility detects unwanted ground fault currents for faults on the DER secondary. This may disrupt coordination among relays at the utility.

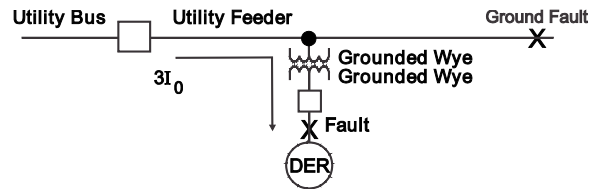

Figure 16: Complications - Grounded Primary and Secondary

## V. Summary

DER installations on distribution feeders are a popular alternative for renewable power assets. As the national standards continue to evolve based on input from their users, informative, uniform requirements provide continuous opportunities for advancement of DER technology. To ensure the safe, reliable operation of distribution systems, the area EPS requires the flexibility to meet specific application's needs.

DER installations will continue to present protection challenges for ensuring safe and reliable power system operation. However, continuing improvement of uniform standards and effective screening processes will help overcome these challenges.

## VI. References

1. IEEE 1547a-2014 IEEE Standard for Interconnecting Distributed Resources with Electric Power Systems Amendment 1
2. IEEE 1547.2-2008 IEEE Application Guide for IEEE Std 1547™, IEEE Standard for Interconnecting Distributed Resources with Electric Power Systems
3. IEEE 1547.7-2013 Guide to Conducting Distribution Impact Studies for Distributed Resource Interconnection.
4. ANSI C84.1-2011 For Electric Power Systems and Equipment— Voltage Ratings (60 Hertz)

5. "*Protective Relaying Principles and Applications – Second Edition*", J. Lewis Blackburn, Copyright 1998 by Marcel Dekker, Inc.
6. "*Generator Protection Application Guide*", August 2014 Basler Electric Company
7. "*Intertie Requirements for DERs Connected to Radial Distribution Feeders*", Gerard L. Gustafson, Basler Electric Company, Presented before the 31st Annual Western Protective Relay Conference, Spokane, Washington, October 16-21, 2004
8. *IEEE C37.2-2008 IEEE Standard for Electrical Power System Device Function Numbers Acronyms, and Contact Designations.*
9. *ANSI C84.1-2011 Electric Power Systems and Equipment—Voltage Ratings (60 Hertz)*
10. Basler PCPC Training School Segment 35, Protection of DG, October 2014

## VII. Vita

Gerald Johnson is the Applications Engineering Supervisor for Basler Electric Company and is based in Richmond, Virginia. Prior to joining Basler in 1999, Gerald spent 29 years in the system protection organization of Dominion VA Power, including 12 years as Director of System Protection Engineering. Gerald is a graduate of Virginia Commonwealth University and is a registered professional engineer in the state of Virginia. He is a senior member of IEEE, a member of the Power System Relaying Committee, a member of IEEE SCC21 Standards Coordinating Committee, and a member of the Texas A&M and Georgia Tech Planning Committees.



Highland, Illinois USA  
Tel: +1 618.654.2341  
Fax: +1 618.654.2351  
email: [info@basler.com](mailto:info@basler.com)

Suzhou, P.R. China  
Tel: +86 512.8227.2888  
Fax: +86 512.8227.2887  
email: [chinainfo@basler.com](mailto:chinainfo@basler.com)