

# New Methods for Detecting Unintentional Islanding for a Distributed-Generation Inverter

Daniel Ransom, PE – Basler Electric Company  
Parsa Mirmobin – Access Energy

## Abstract

Since the first adoption of IEEE Standard 1547 and UL Standard 1741, many connection schemes have been developed for tying a distributed-generation (DG) inverter to the Electric Power System (EPS). Unintentional islanding is not allowed. Quickly removing the DG inverter from the power system keeps the public safe, keeps line personnel safe, avoids EPS damage, and avoids damage to the distributed-generation inverter. Recently, there are new methods to detect islanding that are faster and more reliable.

It is a challenge to detect an islanded condition quickly and reliably. Traditionally, voltage and frequency-limit elements have been used to disconnect the DG for an islanded condition. In this case study, protection elements for impedance (21), power-flow-controlled frequency rate of change (81ROC), and vector jump (78V) are used to detect an islanded condition and disconnect the DG inverter. These elements operate with greater speed and reliability than traditional methods.

This paper presents initial islanding testing for an inverter driven by a high-speed, magnetic-levitation generator powered by waste heat from industrial processes.

## I. The DG System

The distributed-generation (DG) system in this paper uses heat as the fuel source [1]. The heat stream is waste heat that is a byproduct of industrial processes. Heat streams recovered by the unit produce as much as 125 kW of electrical power from the integrated power module (IPM). The IPM is the heart of the system, combining a high-speed, permanent-magnet (PM) generator

with an expansion turbine supported. The turbine is supported on magnetic-levitation bearings.

The system employs a thermal cycle known as the Organic Rankine Cycle (ORC) [2]. DG output power is configurable from 380–480 Vac at 50/60 Hz.

## c) Description of Operation

The power-generation system is connected to a heat source (evaporator), to a condensing source (condenser), and to the electric grid (Fig 1). The working fluid navigates through the unit in a seven-step process that is common to most ORC power-generation systems. The process follows these steps:

Starting at the receiver, the working fluid is in liquid form at the condensing pressure and temperature.

The working fluid enters the pump where the pressure is raised to the evaporating pressure.

The working fluid passes through a heat exchanger (economizer) where it receives heat from fluid leaving the IPM125 expander module, thus improving overall system efficiency.

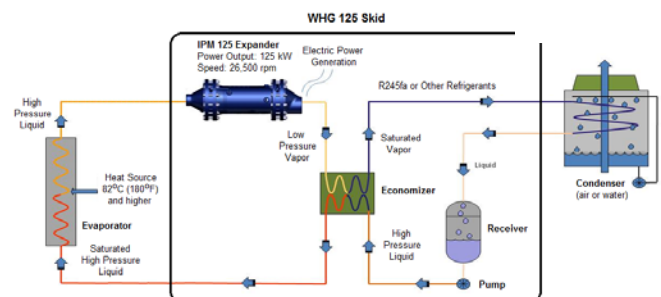

Figure 1. Process diagram shows the flow for the working fluid in the ORC unit

The working fluid is now a warmer, high-pressure liquid. The fluid then enters the evaporator, where it is exposed to the waste heat via a heat exchanger, evaporating the fluid to a high-pressure vapor.

The working fluid (now a vapor) enters the turbine (IPM). Driven by the pressure, the turbine/generator and associated power electronics convert the energy to electrical power that is connected to the power grid at 50 or 60 Hz.

The working fluid still has considerable heat, some of which is transferred to the pumped liquid via the economizer. Preheating the liquid phase of the working fluid results in less heat being required to vaporize the working fluid prior to entering the IPM. This heat transfer also cools the fluid on its way to the condenser requiring less energy for heat extraction rejection.

The working fluid (still a vapor) then enters the condenser where heat is removed, returning the fluid to a liquid. Air-cooled and liquid-cooled condensers can be used. The low-pressure, liquid working fluid drains back to the receiver to complete the cycle.

#### d) Integrated Power Module IPM

A cross section of the IPM is Fig 2. Shown are the generator, expansion turbine, main magnetic bearings, and the backup magnetic bearings. The turbine generator is connected to a power-electronics (PE) package that converts the variable frequency and variable voltage IPM output power. The conversion produces an output for power-grid connectivity with a frequency at 50 Hz or 60 Hz, and a three-phase output voltage from 380 Vac to 480 Vac. Typically, the IPM produces full power at an operating speed of 26,500 rpm; it can produce usable output at a reduced power level to as low as 15,000 rpm. A wide generator operating speed is important because the energy available from many waste-heat sources can vary considerably throughout the day, and on a day-to-day basis.

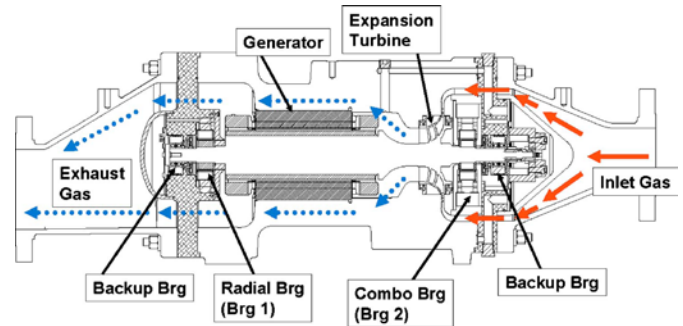

Fig. 2. IPM Cross-section

#### e) Permanent Magnet Generator

Permanent-magnet (PM) generators consist of two basic parts. A stator coil, powered by an alternating current, creates an electric field. A rotor made of special magnetic material rotates within that field. PM generators employ the latest technology in high-strength rare-earth magnetic materials to achieve a large power density and high efficiency. When compared with other motor types, the large power density leads directly to minimum physical size at all power levels. High efficiency yields a significant improvement in overall system efficiency.

#### f) Magnetic-Levitation Bearings

Active magnetic bearings are a non-contact rotor support system replacing conventional mechanical bearings that physically interface with the shaft. Mechanical bearings require some form of lubrication and periodic maintenance. In active magnetic bearings, non-contact sensors monitor shaft position and feed this information to a control system, which regulates current to an actuator to adjust rotor position and provide damping. Active bearing systems, while more complex than passive types, provide much greater support stiffness and are tunable for optimizing system response. In addition, current sensors and speed sensors provide for monitoring and diagnostics.

Magnetic bearings do not require lubrication and the rotating assembly turns with essentially no friction. There is no wear. The efficiency and reliability of the system is optimal because there is no contact between the rotating assembly and the bearing.

### a) Power Electronics

The output of the expander/generator is connected to an active/active power-electronics (PE) package. The power-electronics package uses an insulated-gate bipolar transistor (IGBT) rectifier to convert the variable frequency, high-voltage output from the expander-generator to dc. The inverter electronics then converts the dc to 400 V<sub>ac</sub>/480 V<sub>ac</sub> at 50 Hz or 60 Hz for delivery to the power grid. Flexibility and adaptability are provided by digital-control software that implements control algorithms.

The PE module matches its output to the power grid by sampling the grid voltage and frequency, and then changing the output voltage and frequency of the inverter system to match.

The PE module provides the following protections:

- Overcurrent protection on the grid side of the inverter and on the generator side of the inverter

- Undervoltage and overvoltage protection on the dc-link bus

- Over-temperature protection for the IGBT assembly

- Overfrequency protection for the generator side of the inverter

- Underfrequency and overfrequency protection for the grid side of the inverter

- V/Hz out-of-range protection for the grid side of the inverter (backup grid-loss detection)

- Loss-of-phase protection per IEC 61800

- Out-of-regulation speed control for the generator side of the inverter

- Over-temperature protection for inductors in the dc link

## II. UL 1741 testing and results

Despite the built-in PE protection, the interconnection agreement requires additional detection. An intertie-protection system consisting of an external, multifunction protective relay is used for this purpose.

To ensure adequate external protection response, a test setup was configured as shown in Fig 3. Per UL1741, the setup shows a resonant

circuit (Anti-islanding Tuned L-C Circuit) in parallel with the generation system. The protective relay measured voltage and current at the point of common coupling (PCC).

A simulated power-grid loss was provided by means of a circuit breaker that incorporates an auxiliary contact. This contact was used to record the grid loss event on an external oscilloscope and digital recorder, as well as in the protective relay. Response of the system (including the protective relay) was recorded simultaneously. Figure 4 shows the PE output when commanded to stop operation.

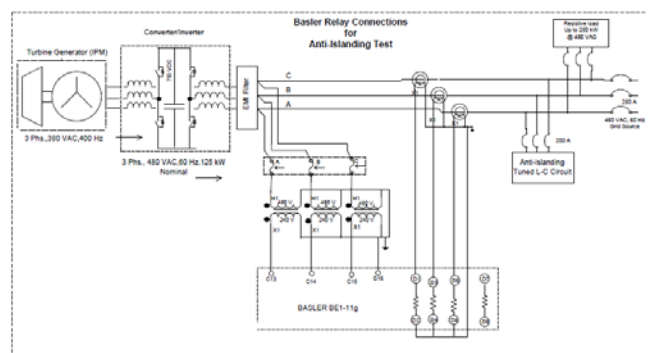

**Fig. 3. Testing Grid Loss—External Protection Relay Test Setup**

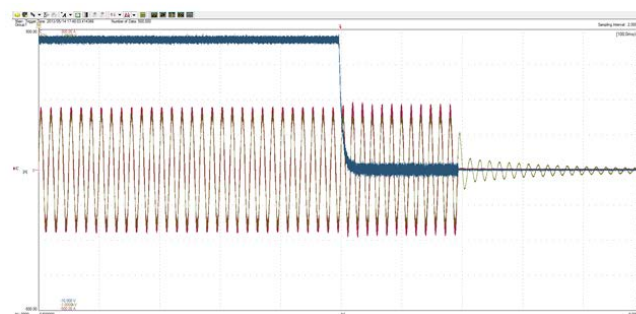

**Fig. 4. DG Output Ceases in 11 Cycles (183 ms)**

## III. Methods of Islanding Detection

It is important to detect the loss of utility power quickly, and to disconnect the DG from the bulk power system. When a fault or abnormal power system event occurs (for example, single phasing or an unexpected load loss) the DG loses the utility-system reference. DG output parameters such as frequency, voltage, and current can

deviate quickly from acceptable levels, especially when the DG is supplying a large amount of power. The electronics in inverter-based DG systems sense these changes in the power system and move rapidly to stop the inverter output.

However, utilities do not often recognize the protections provided by DG inverters. External protection elements, provided by a separate protective relay, are required to monitor the power system. The protective-relay connection is at the point of common coupling (PCC), directly to the utility power grid. (The filtering circuit that is present at the inverter connection in Fig. 3 is for testing only.)

**a) Traditional Methods**

A DG operating with local loads after the loss of parallel operation with the utility is called an “island.” Traditional methods for detecting an island are undervoltage and overvoltage elements (27 and 59), and underfrequency and overfrequency elements (81U and 81O). These protection elements comprise basic “anti-islanding” protection that establishes fundamental operation limits for the DG [3].

**a) Logic Decision to Stop Inverter**

Usually, no single element commands a decision to stop the inverter. A logic output has multiple elements as inputs to stop the inverter. The decision is a combination of elements—a fast-dropping frequency ANDed with a consequent undervoltage, for example. In this manner, protection engineers can configure the islanding detection around the specific operating parameters of the DG/utility-tie connection.

**a) New Anti-Islanding Detection Methods**

Other protection elements can be employed to monitor the utility connection for separation from the DG. These elements include impedance elements 21, frequency rate-of-change elements 81ROC, and vector-jump elements 78V. Power elements 32 assist with monitoring correct power flow and provide tripping for system faults.

**b) Impedance 21 Detection**

An advanced method for detecting islanding uses protection elements that monitor the effective

power-system impedance. An impedance element 21, looking out into the power-utility grid, can detect an islanded condition. Two mho circles provide three zones of operation, as shown in Fig. 5.

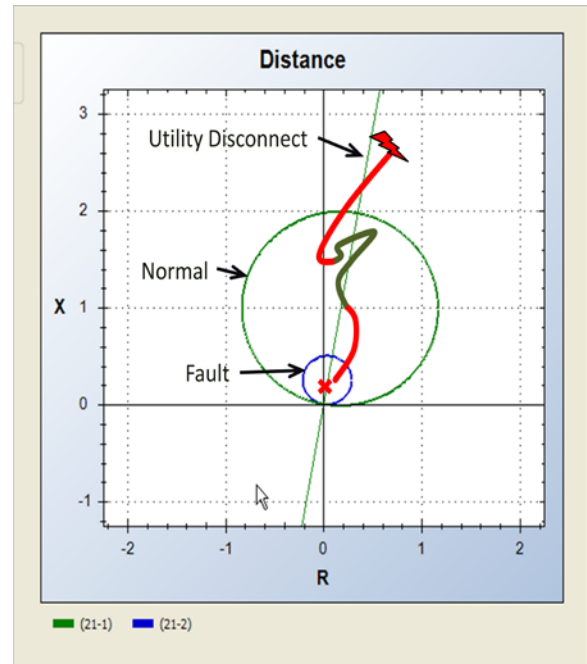
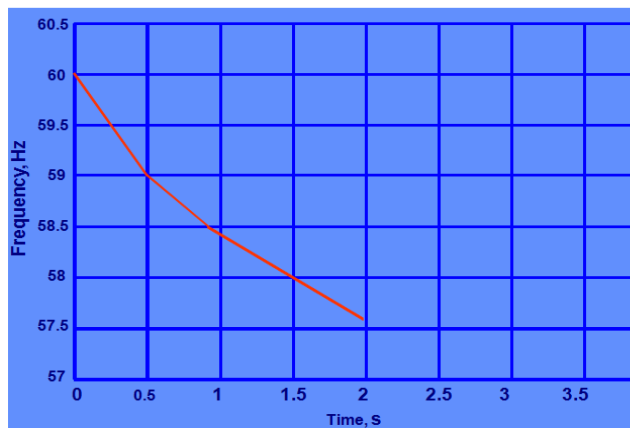

**Fig. 5. Three operation zones: Utility Disconnect, Normal, and Fault**

Normal interconnected operation is in the middle zone. The impedance point (instantaneous Thévenin equivalent) of the voltage/current relationship varies within the middle zone according to varying applied loads. If the utility power system disconnects from the DG, then the impedance point moves into the outer zone. This higher-impedance condition indicates that the connection has opened. The DG has become islanded and the protective relay signals the inverter to shut down. A fault in the DG sends the impedance point on a trajectory into the inner circle, tripping the interconnect circuit breaker.

**b) Frequency Rate-of-Change 81ROC Detection**

A rate-of-change frequency element 81ROC can detect islanding. When disconnected from the grid, the inverter produces a very fast frequency decline (see Fig. 6).



**Fig. 6. Utility loss loads DG—frequency declines quickly**

To add security to this element, the project engineers added supervision with a directional power 32 element. The rate-of-change frequency element is active only when there is a sufficient amount of forward power export into the grid. Fig. 7 shows one method to perform this supervision.

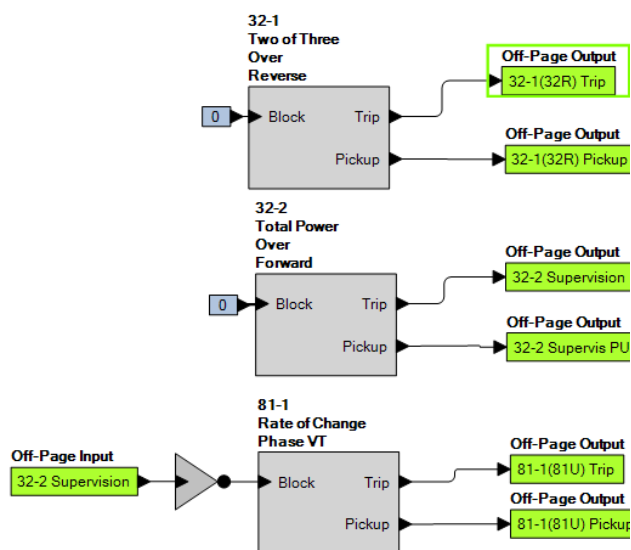

**Fig. 7. Power element 32-2 supervised frequency rate-of-change element 81ROC**

### c) Vector Jump 78V Detection

Another protection element that can detect a sudden power-system disconnect is vector jump 78V. Used extensively outside of North America, the vector-jump element picks up when the voltage phasor changes angular position by a preset amount.

Consider the operating power system as a smoothly rotating flywheel. A sudden disturbance, like the PCC circuit breaker opening, causes a discernible and immediate change in the position of the voltage phasors. The resulting rapid change, or jump, in the smooth, flywheel-like travel of the voltage phasor activates the 78V vector-jump element. This change of phase angle results in an earlier zero crossing of the generator voltage if the generator load decreases. It results in a later zero crossing if the generator load increases. This shift of the zero crossing (vector jump) is expressed in degrees.

Recommended settings are 6 degrees for strong systems. However, weak systems have more instability—a setting of as much as 12 degrees is needed to prevent misoperations from switching heavy loads on weak systems [4].

Once a vector jump is detected, the protective relay sends a signal to stop the inverter, or a signal that adds to inverter-stopping logic. A depiction of vector jump is Fig. 8.

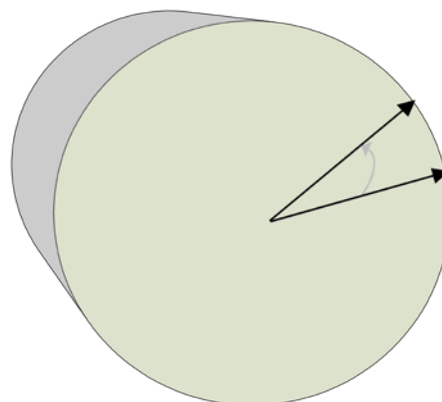

**Fig. 8. Vector jump is a sudden change in the voltage phasor**

## IV. -Islanding Detection Configuration and Settings

For detecting an unintentional island, additional protection elements supplement the basic voltage and frequency elements. These additional elements are power 32, impedance 21, frequency rate of change 81ROC, and vector jump 78V. Logic combinations and level settings for these elements depend upon the parameters of the interconnected DG and the bulk-power system.

This is where the art and science of protective relaying takes effect [5]. Science in the preliminary design configuration stage produces initial logic configuration and settings. Needed for this stage are the Thévenin impedance of the utility system, and the expected fault levels, the interface transformer connection type and grounding method, whether power can be exported to the utility. The art of protective relaying comes at commissioning testing. It is at commissioning that the protection elements are presented with real-world parameters—usually, some adjustments are required.

## V. Fault Detection

The anti-islanding elements are useful for sensing system faults as well. Faults on either side of the PCC reduce and increase voltage, frequency, power and impedance.

### a) Overcurrent 67, 51V Elements

In addition to the anti-islanding elements already discussed, current elements such as directional overcurrent elements 67 and voltage-controlled overcurrent elements 51V can be applied for fast inverter shutdown when a fault occurs. These element pickups are set greater than the level of inverter output current being supplied by the DG to the utility system.

### b) Ground-Fault Protection of DG

Almost every installation will have an interconnecting transformer to match the voltage between the DG and the utility. The transformer connection can be wye, grounded wye, or delta on primary or secondary windings. There is no perfect combination that yields the best situation for all parties—each configuration has advantages and disadvantages. Ground-fault detection depends mostly upon the primary-winding connection of the interconnection transformer. [6]

Most utility feeders are three-phase, four-wire, multi-grounded systems. The transformer at the utility substation has a solidly grounded neutral, and all distribution transformers on the feeder have a grounded neutral.

For a situation where the primary of the DG transformer is ungrounded (delta, or ungrounded-wye primary), when the utility circuit breaker trips

to clear a fault, it disconnects the ground source—the substation transformer at the utility sub. If the DG stays on, it will not sense a ground fault because the feeder is now ungrounded—the unfaulted phases could see as much as 173% overvoltage. Although this is worst case, it is out of utility control once the utility circuit breaker is open. It is the utility customers that will be damaged by this high voltage. Therefore, a protective relay should be placed on the intertie to detect and trip for this condition.

One solution is to monitor a broken-delta voltage from the primary side of the transformer. This protection requires three pts, wye-connected on the DG interconnect transformer primary. Figure 9 shows three-phase PTs wired in broken delta to measure the  $3V_0$ . A resistor is added across the output to prevent ferroresonance.

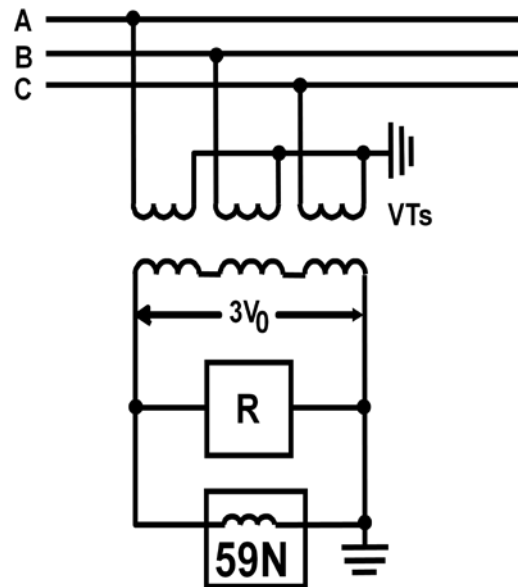

Fig. 9. Detecting a Ground Fault

Suppose that the interconnect transformer has a grounded-wye winding on the DG side (primary side), with a delta-connected secondary. For faults on the utility distribution system, the interconnect transformer acts like a grounding transformer—it supplies a portion of ground-fault current even when the DG circuit breaker is open. This arrangement supplies ground current—shunting operating ground-fault current away from the substation ground-fault detection. For these

grounded-wye primary interconnection transformers, a neutral overcurrent element 51N is used—in some cases a directional ground-overcurrent element 67N is used. For ungrounded interconnection transformers, multiple, single-phase neutral overvoltage and neutral undervoltage elements (59N and 27N) provide protection for ground faults [7].

Problems occur for a grounded-wye/grounded-wye interconnection transformer. If the DG circuit breaker remains closed and there is a ground fault on the DG side, then utility relays will sense more ground current than originally designed. The excess ground current injected by the DG ground fault causes ground-relay miscoordination and possible excess tripping. A 50N or fast 51N detecting 3I0 flowing into the DG is good protection.

### c) Ferroresonance

When the DG and local loads become islanded at this matched or balanced point, damaging ferroresonances can develop in the islanded system. In this case an inverter filter dampens these rogue signals. For systems without adequate filtering a fast, overvoltage element 59 stops inverter operation [8].

## VI. Implementation Testing Results

The planned installation of the magnetic-levitation inverter generators was delayed. Although on-site results are yet to be obtained, testing referenced earlier indicates that the new methods for islanding detection will work well. A follow-on paper will present the real-world results.

## VII. Conclusions

There are new methods for detecting an islanded DG. These methods supplement the traditional islanding-detection methods of undervoltage and overvoltage elements (27 and 59), and underfrequency and overfrequency elements (81U and 81O). New methods include impedance elements 21, frequency rate-of-change elements 81ROC, and vector-jump elements 78V. Power elements 32 assist with monitoring correct power flow and provide tripping for system faults. Impedance elements 21 can detect a loss-of-grid

condition, as well as protect for faults. Rate-of-change frequency 81ROC elements can detect grid disconnect. The vector-jump 78V element can detect grid loss. Detecting ground faults requires correct protection for transformer-utility interconnection.

## VIII. Bibliography

- [1] Hawkins, L., Zhu, L., Blumber, E., et al., 2012. Heat-to-Electricity with High-Speed Magnetic Bearing/Generator System. In: Geothermal Resources Council, Annual Meeting. Reno, NV, USA, 1-3 October 2012
- [2] Yuksek, E., and Mirmobin, P., "High Efficiency Low Temperature ORC System," ASME ORC 2013 Conference, Rotterdam, October, 2013
- [3] Chowdhury, S.P.; Chowdhury, S.; Chui Fen Ten; Crossley, P.A., "Islanding protection of distribution systems with distributed generators — A comprehensive survey report," *Power and Energy Society General Meeting - Conversion and Delivery of Electrical Energy in the 21st Century, 2008 IEEE* , vol., no., pp.1,8, 20-24 July 2008
- [4] Jenkins, N., "Embedded Generation," ISBN 9780852967744, Institution of Electrical Engineers, 2000
- [5] J. Lewis Blackburn, "Protective Relaying: Principles and Applications", 2nd Edition, Marcel Dekker, Inc., 1998.
- [6] Mozina, C.J., "Distributed Generator Interconnect Protection Practices," Transmission and Distribution Conference and Exhibition, 2005/2006 IEEE PES , vol., no., pp.1164,1170, 21-24 May 2006
- [7] Mozina, C.J., "Impact of Distributed Generation," PAC World Magazine, Summer 2008
- [8] Horak, J., "A Review of Ferroresonance," Protective Relay Engineers, 2004 57th Annual Conference for , Texas A&M Univ., vol., no., pp.1,29, 30 Mar-1 Apr 2004

## IX. Vitae

Parsa Mirmobin is the director of System Engineering at Access Energy. He has extensive experience in electrical-system design for aerospace applications and safety-critical system

architecture and protection. Prior to joining Access Energy, he was the Senior Technical Manager at Honeywell Aerospace. Parsa Mirmobin holds several national and international patents and has published a number of technical publications. He has advanced degrees in Engineering/Applied Mathematics from the University of Southampton, United Kingdom.

Dan Ransom has 40 years of industrial and utility electronics experience, including many years in relay protection development and application support. He has extensive experience in consulting engineering for power and communications systems. Dan holds a BSEE from Gonzaga University, Spokane, Washington; he also has a liberal arts degree from Washington State University in Pullman. He is a Senior Member of the IEEE, with membership in the Industry Applications Society (IAS), Power Engineering Society (PES), and Communications Society. He is a Standards Association voting member. To date, he has one US patent. He is a professional electrical engineer in eleven US states. Dan joined Basler Electric in 2010, and is a Principal Application Engineer. He is the protection and communications application engineer for the West region of the USA and Canada.



Highland, Illinois USA  
Tel: +1 618.654.2341  
Fax: +1 618.654.2351  
email: [info@basler.com](mailto:info@basler.com)

Suzhou, P.R. China  
Tel: +86 512.8227.2888  
Fax: +86 512.8227.2887  
email: [chinainfo@basler.com](mailto:chinainfo@basler.com)