

Life Lessons from the Power System

*R. Benjamin Kazimier
Basler Electric Company
Highland, Illinois, USA*

*Gerald Johnson
Basler Electric Company
Highland, Illinois, USA*

I. Introduction

Adhering to the basic tenets of the power system greatly benefits engineers, planners, operators, and consumers of electrical energy. Along the way, while working in power system protection, you will learn a few valuable lessons. Protection, like life in general, is about three major areas: relationships, moderation, and balance. A relay engineer may say that relationships are similar to a synchronizing (25) element or a distance (21) element. The relationship works best when the two sources have voltage and currents that are matched, steady, and healthy. Undervoltage (27), undercurrent (37), overvoltage (59), and instantaneous/inverse overcurrent (50/51) are instances when one applies the moderation principle in which too little or too much of a good thing may be undesirable. The balance and conservation of power is best described by the current differential (87) element, where the current input and current output must match. This paper explores the basic principles of relay protection design and relay protection commissioning, while reflecting upon lessons learned.

II. Relay Protection Design

A. Why protect?

Before discussing relay protection design, it is important to revisit the “why” of protective relaying. A power system that is provided, operated, and maintained effectively is paramount to the success of an industrial or commercial endeavor. Protective relaying is one of the key elements to be considered in the power system design. Overall system protection is accomplished via the coordinated application of protective devices including fuses, circuit

breakers, and relays. Protective relays are devices that monitor power system conditions and operate quickly and accurately to isolate faults or abnormal conditions. It is important to understand that protective relays, by nature, are reactive devices, not in the electrical sense, but in the sense of the antonym of proactive. A protective relay will not prevent a fault from occurring, but it will react to a particular electrical condition and, if properly applied, will prevent or limit damage to the system. Another important concept in protective relaying is the difference between faults and abnormal conditions. Faults are short circuits or arcs (actual system failures). Abnormal conditions are events such as overvoltage, undervoltage, or overexcitation. Abnormal conditions are undesirable events and often lead to faults or equipment failure. Most relays are applied to protect against faults or abnormal conditions. This governs the philosophy of the protection system.

B. Five basic facets

J. Lewis Blackburn described the five basic facets of protective relaying: “Reliability, Selectivity, Speed of Operation, Simplicity, and Economics”. Although these principles were conceived many years ago, the concepts are still valid today.

Reliability

Reliability is comprised of two parts, dependability and security. The IEEE defines dependability as “The facet of reliability that relates to the degree of certainty that a relay or relay system will operate correctly.”(C37.100) Security is “That facet of reliability that relates to the degree of certainty that a relay or relay system will not operate incorrectly.”(C37.100) Reliability may cause much difficulty in the life of a relay engineer because, generally, dependability and security are rather inversely proportional. Blackburn states, “The practical and best answer to both security and dependability is the background experience of the designers, confirmed by field experience.”

Copyright 2015 IEEE. Personal use of this material is permitted. However, permission to reprint/republish this material for advertising or promotional purposes or for creating new collective works for resale or redistribution to servers or lists, or to reuse any copyrighted component of this work in other works, must be obtained from the IEEE.

To that end, the new relay engineers of today must learn from their more experienced peers and others who have come before them to properly understand and implement protection systems. Additionally, for this reason, starting with a blank screen for a protection design is not good practice.

Selectivity

Selectivity is the ability of a relay to recognize a fault or abnormal system condition and to discriminate between those upon which it should and should not operate. For example, the selective nature of time overcurrent coordination allows for protection of a primary zone such as a substation transformer and, at the same time, provides backup zones of protection for the low-side bus and distribution feeders. See Figure 1.

Speed of Operation

At first, speed of operation may not seem like a difficult concept to grasp. High speed can be considered advantageous when it refers to fault duration of the primary zone of protection. The amount of time a fault persists and the amount of damage incurred are directly proportional. Thus, isolating faults as quickly as possible should always be the goal for a protection system, but it should do so without affecting the stability of the power system, i.e. not disrupt selectivity by maintaining coordination with upstream and downstream devices. When considering the speed of operation of a relay or relay element, one must consider the system as a coordinated entity to maintain selectivity. Consider the system shown in Figure 1. Ignore the 50 elements for the first part of the example and focus on the coordination of the primary (feeder time overcurrent (51)) and backup zone. Consider a phase to ground fault at point A on feeder 1. To maintain selectivity, the feeder relay trip time is based on available fault current, relay

minimum pickup setting, characteristic of the inverse time curve, and some margin. At the same time, the backup ground (BUG) 51 on the transformer senses the fault at point A and begins its coordinated response. This response is intentionally slower than the feeder 51, but fast enough to prevent damage to primary components if the feeder 51 does not clear the fault. The operations impact of a backup trip, or overtrip of the backup relay, is loss of the substation, which results in substantially more customers out of service for a much longer period of time (transformer locked out). Therefore, speed of operation must be carefully coordinated to prevent damage and maintain selectivity.

Engineers should also be aware of the impact of what is known as the "ratcheting" effect. To demonstrate this concept, imagine that during a heavy electrical storm, lightning strikes occur on multiple feeders on the same bus that causes the BUG relay (for this example BUG is an electromechanical relay) to begin timing towards a trip. The relay begins to reset because the fault duration is short, but then it prematurely times out because it was not fully reset when the next lightning strike occurred. This causes a trip of the entire station. This phenomenon is known as the ratcheting effect and is based on the timing between and number of lightning strikes in a given period of time and the time required for the electromechanical induction disk to return to the fully reset position. Although rare, this event does occur. Today, many numeric relays provide the user with options for how the 51 elements reset, either instantaneous or integrating. Integrating reset mimics the induction disk, returning to zero like an electromechanical relay, i.e. not instantaneously. To minimize the impact of the ratcheting effect, an engineer should select the instantaneous reset of the 51 element for the BUG relay.

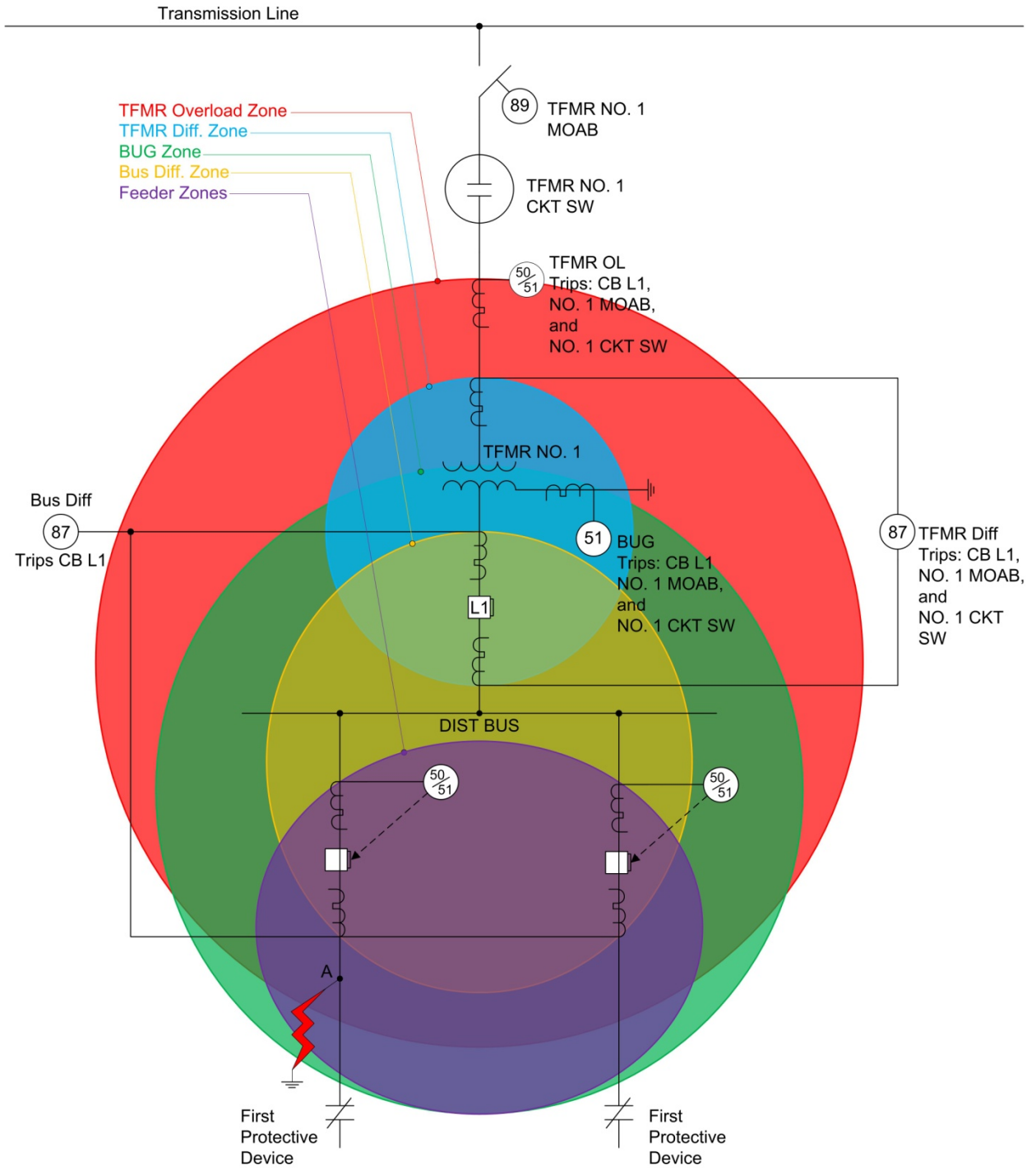

Figure 1: Zones of Protection

Simplicity

Simplicity is defined by Blackburn as the “minimum protective equipment and associated circuitry to achieve the protection objectives.” In modern protective relaying, this tenet is one of the easiest to break. In the past, electromechanical or solid-state protective relays were applied on a per-phase stand-alone basis, single function per phase. Yesterday’s typical relay panel at a facility with on-site generation may have consisted of a combination of instantaneous overcurrent and inverse time overcurrent relays for phases A, B, C, and N, or possibly directional overcurrent relays, depending on the voltage at the interconnection point, a reverse power relay, over- and undervoltage relays, over- and underfrequency relays, and a negative-sequence voltage relay. Depending on the generator status (on or off), automatic reclosing and synchronizing may also be included. The total scheme consisted of the different relays and switches mounted on a panel with somewhat complex point-to-point wiring.

With today’s microprocessor-based relays, all of this can be done with a single protective relay as well as the inclusion of controls such as opening and closing a breaker or reclose on/off, metering that historically was provided as separate Volt / Amp meters, communications, fault recording, and so on. The equipment count is reduced and functionality is greatly increased. Albert Einstein said “Everything should be made as simple as possible, but not simpler.”(Stanford) This is applicable to protective relaying today and, in fact, this notion has never been more relevant. This strategy must be implemented in order to adhere to the aforementioned facets of reliability and selectivity. Underprotected circuits (too few elements) are as detrimental to reliability and selectivity as overly complicated protection schemes (too many elements or logic that is difficult to understand). It may be necessary for the contemporary relay engineer to understand that just because one can put more protection elements on a circuit, it does not necessarily mean that one should. Furthermore, because all of the protective functions can be combined into a single relay, this does not mean that it should be done without including a backup plan. For example, the scheme mentioned above could be deployed in a single relay but, if that relay fails, all of the protection for the circuits involved will

fail. A second relay for backup could be included in the protection design to maintain reliability.

Economics

The designer should consider the cost of installation, operation, and maintenance versus potential losses caused by equipment damage or service interruption. Fortunately, microprocessor-based relays are generally less expensive to apply than single function relays by virtue of the example given in the aforementioned simplicity discussion. It is also noteworthy to consider, as mentioned above, that it may be more economical in the short term to use a single relay without a backup relay; however, the inclusion of the backup relay increases reliability. The cost of deployment for backup protection must be weighed against the need for reliability. Downtime can be very costly depending on the operation, and it is generally unwise to allow a circuit to remain unprotected in the event of a relay failure while a replacement is acquired. This can be mitigated—to a point—by purchasing and maintaining a fleet of spare relays in lieu of backup protection.

C. We’ve always done it that way

When designing a protective relay scheme it is generally agreed that starting with a blank slate is not a good practice. A designer should use tried and true, well-documented schemes with a proven history of field performance. Individuals new to the field need not be overwhelmed. Many valuable resources are available for protection design through various texts, including relay operation manuals (that generally give application examples), industry standards organizations such as the IEEE and, more specifically for relay engineers, the Power Systems Relay Committee (PSRC) within the IEEE. Additionally, the experience of one’s peers cannot be overstated as a valuable resource. With information so readily available, there is no reason for a protection designer to start with a blank screen. Conversely, it is not wise to blindly copy protection schemes verbatim from one project to the next. Similarly, one should challenge the statement, “we have always done it that way”, for some of the same reasons. A potentially unknown error could be replicated many times. One must take the time to understand what protection is being applied, why the protection is being applied, and use the opportunity to either further prove the scheme’s validity or find previously unknown errors or

misapplications. Furthermore, and somewhat surprisingly so, it is still relatively common to apply protection packages that, while valid, are based on technology that is aging, e.g. single function relays. The same protection afforded by single function relays, along with the other benefits of modern relays such as fault recording, sequential events records, and metering, could be achieved with a single relay. Generally, multiple single function relays add up to a more expensive protection package than a single numeric relay and require more complex wiring schemes. Converting a standard design from single function relays to a single numeric relay requires the designer to spend engineering time to specify a device and update the drawings, but the benefit to the end user is extremely valuable, especially as older technology is phased out and replacements become difficult to acquire. While “we have always done it that way” is comfortable for some and may seem economical today since less engineering time is required, there may be a steep penalty in the future if an unknown error causes issues with every iteration of the scheme or a retrofit job is required prematurely because replacement relays are no longer manufactured.

D. Protection design can be challenging

Designing a protection system can be a challenging task. As described above, there are several important concepts to consider. In addition to the five basic tenets, it is important to highlight the peer review process. The example below emphasizes the need for peer reviews throughout a project’s lifecycle, from design to commissioning.

During a recent series of incidents at a power plant, a medium-voltage compressor motor experienced thermal capacity (49TC) operations during restarts. When attempting to troubleshoot the issue, it was suspected that something may

have been wrong with the protective relay because the recorded fault data did not make sense to plant personnel. After viewing these records, the plant personnel concluded that the 49TC operate time was shorter in duration at the time of fault than expected. However, this proved to be invalid for the following reason: one cannot simply look at a snapshot of the current during an actual motor event and relate the trip time to a point on the 49TC curve. The previous heating condition of the motor also must be considered. One might consider the 49TC element for a motor to be like a bucket with a spout at the top (representing current into the motor) that fills the bucket and a drain at the bottom (representing the motor’s rate of cooling); see Figure 2. Imagine that the top valve opens wider when more current is flowing and narrower when less current is flowing. All the while, the bottom valve lets out water based on the rate of cooling of the motor, which is different for stopped and running conditions. The 49TC element observes the current flowing into the motor over time and, based on the programmed cooling time constants (running and stopped), calculates the equivalent heating in the motor. This is continuously determined even when the motor is stopped, so the thermal capacity can be approximated to zero (motor at ambient). This concept was not well understood during troubleshooting. By returning to the basics and reviewing the settings, it was determined that the programmed Full Load Amps (FLA), Service Factor (SF), the running and stopped time cool constants, and the 49TC time dial were programmed incorrectly. This led to the 49TC element being very loosely coordinated, set too low when compared with the actual motor damage curve. See Figure 3. Additionally, because of the 49TC miscoordination, the restart inhibit function was incorrectly set, allowing for restarts that exceeded the programmed thermal capacity.

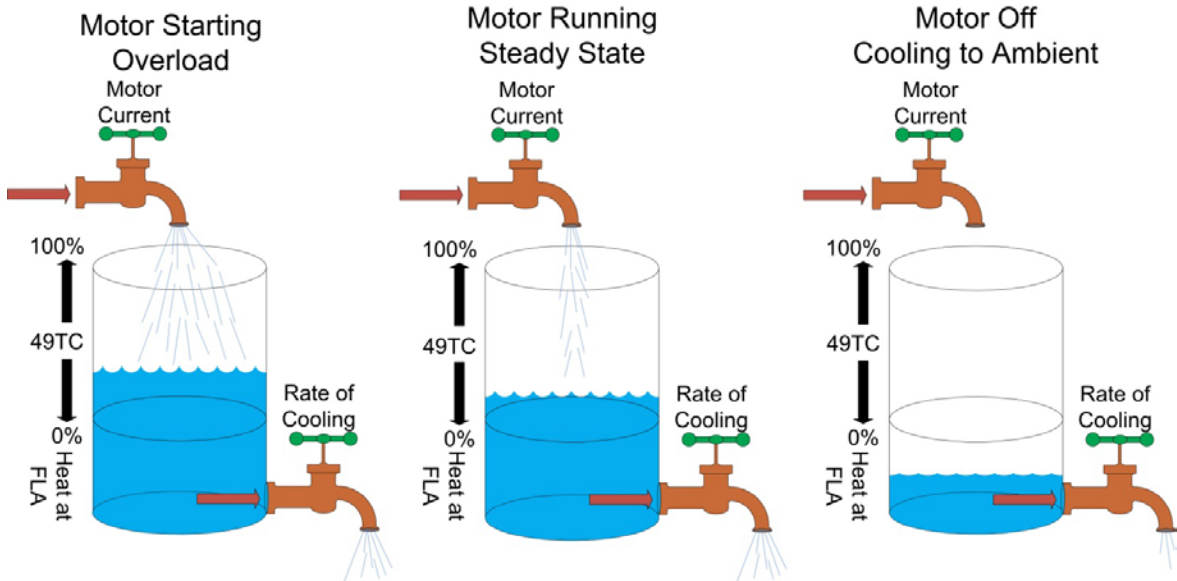

Figure 2: 49TC Explanation

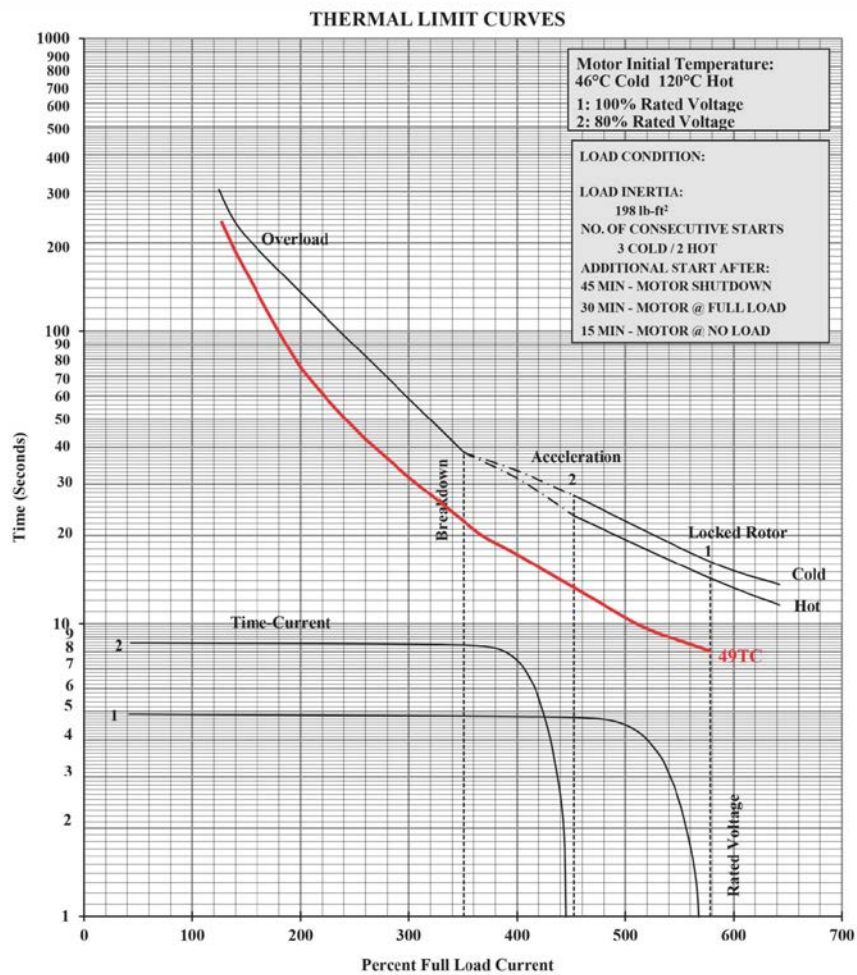

Figure 3: Motor Thermal Limit vs. Programmed 49TC

There are several key lessons to learn from this incident:

- A peer review or correspondence with the relay manufacturer's application group during the protection design process could have prevented the improper 49TC configuration. The engineer attempted to use the FLA and SF settings to manipulate the 49TC curve instead of using the features intended to do so, e.g. Overload Scaling and Time Dial.
- The errors were made three times because the identical settings file was used for each of the three motors.
- While investigating the incidents, plant personnel failed to believe the relay was operating as programmed. It is important to note that if a numeric relay is metering correctly, the relay is most likely working properly as programmed in terms of the protection elements. Because the calculations for protective elements are fixed in the relay firmware, if the currents and voltages are being resolved properly by the relay, it is an acceptable practice to believe the relay is working as programmed. Attempting to determine what has happened after a trip of this nature is a complex task and, because experience has proven that such undesired relay operations are usually the result of a programming error, it is best to review the settings in detail as the first troubleshooting step to see if an issue or inconsistency can be found.
- The engineer who created the settings file was not consulted after the issues arose; therefore, there was no opportunity to help plant personnel with the misoperation issues.
- Following good commissioning steps for this motor protection scheme may have prevented these errors. For example, if during testing and commissioning the technician had cross-checked the settings with the motor nameplates and motor data sheets, a discussion regarding the inconsistencies could have taken place at that time, possibly leading to a satisfactory resolution prior to final deployment.

- After the settings were revised, inputted, and saved to the relays, no further misoperations were observed.

III. Commissioning Relay Protection

Few things in a relay engineer's life are more satisfying than seeing one's design implemented in the field. However, misoperations on a system that one designed might result in one of the most disappointing and stressful days for a relay engineer. The report of a relay misoperation may send a flood of thoughts through the mind of the engineer responsible for the protection portion of the project: are the elements correct for the application, are the settings correct, were the settings modified during testing but not reloaded, or was there a mistake in the programmable logic? The best way to prevent such a scenario is to use a well designed protection system commissioning program. Because more than one commissioning method is acceptable, this section explores the topic in a general sense and provides some recommendations and resources.

A. Test and commission as a system

With regard to the commissioning of protection systems, the IEEE states that "Commissioning tests are intended to ensure that the protection system will operate as designed after field installation. These tests verify the individual components, interactions between components, communications system, and scheme redundancy along with wiring and installation." (C37.233) Because protective relays have advanced, it is important that commissioning procedures are updated as well. In a presentation recently given by the I5 subcommittee of the PSRC, it was suggested that, "The functions performed by relaying systems that use earlier technologies are defined more by the wiring than by the setting of the relay." (I subcommittee) This is contrasted against modern schemes where more functions are put into a single box, wiring is decreased, and programmable logic schemes exist to take the place of physical wiring which is replaced, in a sense, with logical wiring. Today, transistors make up the complexities that were physical wires, lugs, and screw terminals. For the reasons previously stated, one must again challenge the "we have always done it that way" approach when commissioning protection systems. For example, conducting point-to-point

wiring checks is still very important to validate a protection system's operation, but today it tells only a small part of the story depending on the complexity of the relay and the application. To illustrate, suppose that while commissioning a switchgear lineup a technician performs point-to-point wiring checks as a drawing indicates, from the Output 1 terminal of a relay through a terminal block down to the secondary disconnect of the breaker it is intended to operate in the event of a fault. A second technician tests the relay mentioned above by drawing it out from its case and placing it in a case on the test bench. By looking at the settings and programmable logic, the technician determines that Output 2 is mapped to the protective trip functions and tests it accordingly. If this is the extent of the testing on this circuit, there will clearly be an issue. Instead, the protection system should be evaluated and checked as a whole. The drawings should be cross-checked against settings in the relay and the protection design engineer should be consulted to determine what was intended in the relay programming. Furthermore, a final step in the commissioning process, such as installing the relay in the switchgear and initiating a trip to verify that the circuit breaker operates as intended, would further validate or disprove proper operation. This is an example of a functional test, more specifically, a positive functional test.

B. Functional testing

Functional Testing, also called trip checking, is a keystone activity of commissioning. This is not a time to cut corners. The intent is to confirm that the protection and controls function as intended and that there are no unintended consequences. It is important to consider that there are two different types of functional tests to perform, positive and negative, not in the electrical polarity sense, but as further explained. Checking that a design works correctly is called a "positive" test. Verifying that a design does not work *incorrectly* is called a "negative" test.

To demonstrate this concept, consider the simple protection scheme shown in Figure 4. The phase overcurrent elements trip the breaker directly. The ground element trip output has a cutout switch that must be closed to trip the breaker. To test, a phase overcurrent element is operated to make certain that the breaker trips as intended. Note that the relay contact should be forced to close with a test set instead of simply applying a jumper across the contact. A

target should be confirmed after the trip. Next, the ground cutout switch should be opened and an attempt to trip the breaker with the ground element should be performed; the breaker should not trip. With the ground relay trip contact still closed, the ground cutout switch should be closed to confirm that the breaker trips. This proves that the cutout switch prevented tripping of the ground element and no unintended results were observed. These are positive tests.

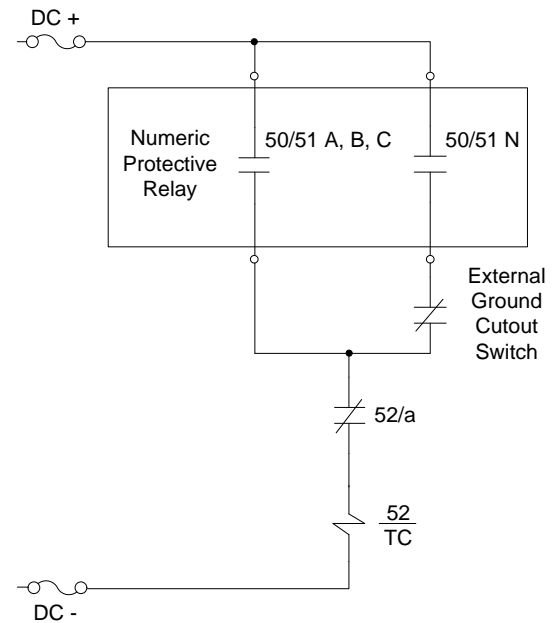

Figure 4: Simple Overcurrent Scheme

Negative tests are more difficult to define. One must look for ways a circuit could operate in some unintended manner and test for that condition. For example, suppose the circuit in Figure 4 needs to be taken out of service for maintenance. The fuses are removed to de-energize the control power to the trip circuit. Imagine that the fuses are located next to other fuses in the panel but were not labeled correctly, and the wrong fuses were removed. While working on the circuit, the breaker could be tripped because the fuses were labeled incorrectly and control power was not removed from the trip circuit. This is an unintended consequence that cannot be discovered by performing a positive functional test to prove the circuit works correctly with everything normal. Note that such an error could be found by point-to-point wiring checks but properly designed negative functional tests serve as cross-checks to the point-to-point checks.

Another example is in reference to Figure 5 where our schematic diagram was intended to be identical to Figure 4, but was accidentally miswired as shown. Instead of cutting out the ground element, the ground cutout switch prevents tripping for all of the elements. If only the positive checks are performed to confirm tripping as described above, where the phase overcurrent element is operated to make certain that the breaker trips as intended (note the ground switch is closed) then, with the ground cutout switch open, an attempt to trip the breaker with the ground element is performed and, as expected, no trip occurs. Next, with the ground relay trip contact still closed, the ground cutout switch is closed and the breaker trips. The circuit appears to work correctly based on this series of tests. If the evaluation is stopped at this point, it will not be discovered that the phase elements are also opened by the ground cutout switch. To make a negative test for this circuit, when the ground cutout switch is open and it is confirmed that the ground element does *not* result in a trip, it should also be confirmed that the phase elements *do* result in a trip. Complete negative testing involves checking every possible combination and permutation in a circuit. While reasonably possible in the sample circuits above, for a more complex scheme it may not be practical to check every possible combination. For more complex circuits, one should concentrate on performing negative tests that are designed to find more obvious errors such as improper wiring or identification. Again, the error described above could have been discovered during point-to-point wiring checks, but when commissioning protection systems, cross-checks are invaluable, especially considering the complexity of some protection schemes and what is at stake if the system is deployed incorrectly. Consider positive and negative functional tests as a kind of peer review to the point-to-point wiring checks.

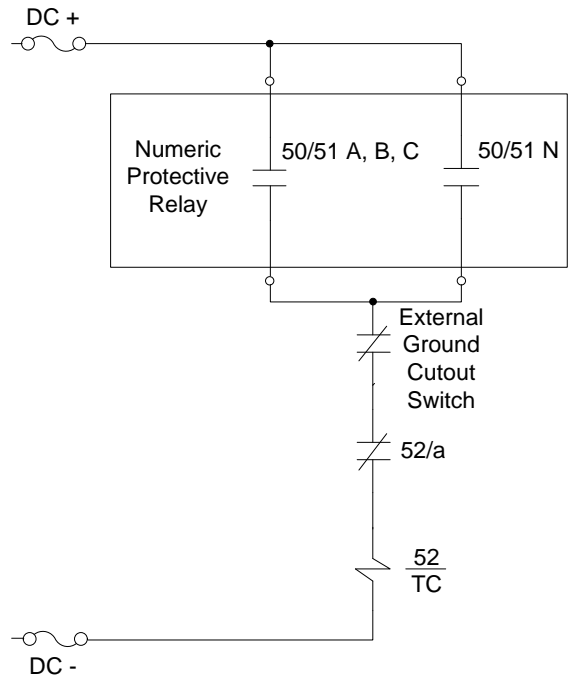

Figure 5: Miswired Simple Overcurrent Scheme

C. In-Service Readings

A recommended final test in the commissioning of a protection system is to perform in-service readings. Most numeric relays display the measured values of current and voltage that are used by the relay for protection. Generally, these values can be compared to other values in the relay in terms of phase angle. Fundamentally, there is nothing wrong with using these displays to perform in-service readings so long as one knows that the relay is, in fact, connected correctly. Using these displays is not different than picking up a new phase angle meter. At some point one must confirm the relay metering display is correct. When the relay is tested, the metering display is checked by inputting known current, voltage, and phase angle from a test set. If the display is correct with a known source, there is no reason to use another instrument for in-service tests. When the test set is connected, pay particular attention to the lead-lag convention of the relay and what quantity the relay uses as a reference. For example, if A-phase current is used as a reference for the phase angle readings, the angle for A phase will be 0 degrees. If B phase is 240 degrees, is that lead or lag? There is no standard; make note of it before final commissioning of the relay. Knowing the lead-lag convention used in the relay helps to determine the phase sequence of

the quantities applied to the relay. Most modern numerical relays can calculate sequence components for use in metering and protective elements. This may not seem important if the sequence components are not being used for protection, but the functionality may be needed in the future. Additionally, proper sequence makes negative-sequence metering correct. Because end users or other personnel may view the relay metering values in service, it is conceivable that one may become alarmed at odd looking readings. Therefore, it is best to verify these metering screens during commissioning and make corrections as necessary to prevent potential issues. Most relays can set the normal phase sequence inside the relay, either ABC or ACB. This setting should be identified on the setting sheets so it can be confirmed in the testing and commissioning phases. This is confirmed during commissioning by reading the metered value of the negative-sequence current. It should be negligible for balanced load conditions. If it is not, check the phase sequence setting and CT wiring.

D. File management

Protective relay settings file management is another area of focus when testing and commissioning relay systems. Because the majority of protection schemes in our modern protection world is in a single box and is only as effective as the programming within, proper handling of the settings files is of utmost importance. During testing, it is common for the test technician to disable or change the settings for particular elements so that another element can be tested. An example of this is disabling a Current Differential element (87) so that a single phase test can be completed on an Instantaneous (50) element. If the 87 is not disabled, it may trip when the single phase 50 test is executed. It is imperative that, at the end of testing, the relay is returned to its in-service settings. There are different ways to do this. For example, one might always download a settings file and save it to a location where it is not altered, perform the testing using a copy "test" file, and reload the original file after the testing is completed. Another may make settings changes in a "live mode" and revert back each setting as tests are completed. A third technician might use a test set that runs automated tests, turning settings off and back on as necessary per the test program. Because these automated test

programs are created by humans, there is always a chance for human error to exist. At the completion of automated tests, it should be verified that the original settings file is reloaded into the relay. Most relay software has a settings compare feature which detects differences between two settings files. Such a feature can be used in all cases to double check that settings left in the relay are identical to how it was intended to be programmed.

E. Commissioning Summary

As mentioned previously, there are many commissioning methods. The most important considerations are to seek out best practices and to find a method, stick with it, and refine as necessary. Literature available to aid in protection system commissioning is becoming more readily available especially with respect to modern numeric relays. Manufacturers now offer commissioning documents and papers on the subject. Many relay user manuals contain testing sections that can be easily modified for use with the in-service settings for a particular element. Other resources include the *ANSI/NETA Standard for Acceptance Testing Specifications for Electrical Power Equipment and Systems* and *C37.233-2009 IEEE Guide for Power System Protection Testing* contains very useful commissioning information including end-to-end testing for line protection, which is extremely beneficial to the entire industry. The IEEE PRSC working group I25 is drafting a report titled *Commissioning of Substation Protection and Control Schemes* which is expected to be published in 2016. With such resources available, protection engineers should seize the moment and use this information to properly design, update, and implement a commissioning strategy that can help ensure the success of a protection project.

IV. Conclusion

When designing and commissioning a protection system, adhering to best practices and following lessons learned gives the project the greatest chance for success. The concept of protection as a set of values (relationships, moderation, and balance) advances the notion that the success of a protection project is also linked to these key areas. Peer reviews require a working relationship with other engineers in the field who can apply their experience to a project. Applying the knowledge of one's peers ensures that a

multitude of lessons learned from different individuals is applied to a project that otherwise would draw from only a single engineer's perspective and personal experiences. Peer reviews can help to reduce mistakes and unforeseen errors on a project. With many in the protection workforce nearing retirement, it is important for new engineers to seek reviews from their more experienced peers. That knowledge transfer helps to make current and future projects successful. The concept of moderation was evidenced in different ways. The method an engineer uses to deploy a reliable system depends on a balance of dependability, security, and economics. Similarly, negative functional tests must be used in moderation and balanced against the time allowed for commissioning. One must choose the negative tests most likely to find issues with the particular design because, for many schemes, the permutations for performing every possible negative test are inconceivable. In the end, as engineers, the goal is to keep reliable and safe electric power available to the grid, hospitals, public utilities, and industrial facilities. Working together with our peers across the industry, applying moderation and balance to protection design projects are the cornerstones to reaching that goal.

V. References

ATS-2013 ANSI/NETA Standard for Acceptance Testing Specifications for Electrical Power Equipment and Systems

"Schematic Representation of Power System Relaying", A report to the Relaying Practices Subcommittee I, Power System Relaying Committee (PSRC), IEEE Power Engineering Society

C37.233-2009 IEEE Guide for Power System Protection Testing

C37.100-1992 IEEE Standard Definitions for Power Switchgear

C37.2-2008 IEEE Standard Electrical Power Systems Device Function Numbers, Acronyms and Contact Designations

"Commissioning Numerical Relays", Basler Electric

"Extending Motor Life with Updated Thermal Model Overload Protection", Basler Electric

Harris, Kevin. "Collected Quotes from Albert Einstein." *Stanford Residential Computing*, 1995.

"Protective Relay Basics", Basler Electric, Power Control and Protection Conference, October 2014

"Protective Relaying Principles and Applications – Second Edition", J. Lewis Blackburn, Copyright 1998 by Marcel Dekker, Inc.

VI. Vita

R. Benjamin Kazimier is a Senior Application Engineer with Basler Electric Company. Before joining Basler Electric, he graduated in 2000 from Ivy Tech State College in Indiana with an Associate of Science in Electronics Technology. After graduating, he entered the cellular communications field. In 2008 he earned a Bachelor's Degree in Electrical Engineering Technology from Purdue University. Ben joined General Electric Company as a power delivery field engineer and reached the position of Lead Customer Service Engineer. His work experience includes design, installation, testing, and commissioning of protective relaying equipment and a diverse range of power system apparatus. He is a member of the IEEE and regularly attends IEEE-PSRC functions and 1547 working group meetings.

Jerry Johnson is Application Engineering Supervisor for Basler Electric Company and is based in Richmond, Virginia. Before joining Basler in 1999, Jerry spent 29 years in the System Protection organization of Dominion VA Power, including 12 years as Director of System Protection Engineering. Jerry is a graduate of Virginia Commonwealth University and is a registered professional engineer in the State of Virginia. He is a senior member of IEEE, a member of the Power System Relaying Committee, a member of IEEE SCC21 Standards Coordinating Committee, and a member of the Texas A&M and Georgia Tech Planning Committees.



Highland, Illinois USA
Tel: +1 618.654.2341
Fax: +1 618.654.2351
email: info@basler.com

Suzhou, P.R. China
Tel: +86 512.8227.2888
Fax: +86 512.8227.2887
email: chinainfo@basler.com