

## GET IN STEP WITH SYNCHRONIZATION

Daniel L. Ransom, PE  
Senior Member IEEE  
Basler Electric Company  
12570 State Route 143  
Highland, Illinois 62249 USA  
danielransom@basler.com

**ABSTRACT**—This paper presents a review of power-system synchronization. When two sources are paralleled, it is crucial to close the interconnecting circuit breaker when both sources are in voltage, frequency, and phase coincidence.

Operators can synchronize manually, or use the latest, state-of-the-art autosynchronizers (device 25A) and sync-check relays (ANSI/IEEE device 25) [1] to automate closing. Generator and bus synchronization share most principles, with some important differences for each type of synchronization. For generation plants, closing manually or applying an automatic synchronizer depends a lot on the plant configuration and operating mode. For bus-line applications, synchronizing depends on power-system stiffness, motor loads, and whether a wye-delta transformer is between the line and bus. Methods for attaining proper sync-check and fast synchronization are discussed.

Index terms—synchronization, sync check, synchronizer, closing, protective relays, voltage, frequency, phase

### I. Introduction

Synchronization is the process of matching the voltage, frequency, and phase angle of a source (a generator) to an existing power system, making it possible to operate these systems in parallel. When paralleled, the synchronized power systems can exchange power and load flows. Sources must have (nearly) identical voltage magnitude, frequency, and phase-angle relationships to parallel two systems safely. Proper synchronization provides the following outcomes:

- Minimum disturbance to the two paralleled systems
- Minimum shock to an oncoming generator (mechanical and electrical)
- Equipment lasts longer; saving money
- Rapid loading of the oncoming generator provides power to loads quickly

When two segments of a grid are disconnected, these segments cannot exchange power and load again until the systems are brought back into synchronization.

### II. History

One of the arguments against alternating current began during the War of Currents in the late 19th century [2]. Early inventors were concerned about connecting together two power systems. At first it was considered too complex; it was too difficult to match the frequency of two ac (alternating current) power systems so that these systems could be paralleled to share growing loads. During the War of Currents George Westinghouse and Thomas Edison became adversaries, with Edison promoting direct current (dc) and Westinghouse endorsing alternating current (ac) as the standard for electric-power distribution.

Three-phase ac power distribution “won” the war because of the ease of converting one ac voltage level to another to distribute electric power. However, the problem of paralleling ac systems was more difficult with ac than with dc. In dc systems only the amplitude needs to be matched. However, in ac systems the magnitude, frequency, and angle of the two systems must be matched to connect the power systems (from different generator sources) in parallel with minimal system disturbance.

Early attempts at paralleling power-system sources were aided by Nicola Tesla’s work on three-phase ac power systems. Rudimentary investigation showed the possibility of paralleling sources. Soon it was apparent that sources must match in voltage amplitude, frequency, and especially in phase angle, to eliminate disturbances in the power system upon paralleling.

### **III. Considerations for Synchronization**

Certain conditions must be met to reach synchronization, where two ac systems can be connected with no harm to both systems and to the connected loads. The oncoming source must match these power-system quantities to those of the existing system:

- Phase sequence
- Voltage amplitude
- Frequency
- Phase angle

#### **A. Phase Sequence**

Phase sequence is very important for proper synchronization. The phase sequence (for example, A-B-C or A-C-B) of the oncoming system must match the order of the phase sequence of the existing power system. The process of matching the sequence is referred to as “phasing,” and the sources are said to be “in phase.”

#### **B. Amplitude, Frequency, and Phase Angle**

The voltage amplitude, frequency and phase angle must be controlled each time a generator is connected to a power system. In practice, reaching the exact point where voltage amplitude, frequency, and phase angle match perfectly, and then closing an intertie circuit breaker at this precise moment is not possible. Instead, systems are paralleled within an acceptable tolerance window for mismatches of these three important quantities.

The term “window” describes the acceptable limits of the real-world mismatch of synchronizing quantities. If an oncoming generator output is within the window for voltage amplitude, frequency, and phase angle, then two power systems can be paralleled with little disturbance. Defining this synchronization window is essential for adjusting (via manual methods or an automatic synchronizer [25A]) the voltage amplitude, frequency, and phase angle of an oncoming generator, and for setting a protective relay to monitor for conditions inside this window (25, sync check) to allow connection of the two systems. See the synchronization window in Fig. 1.

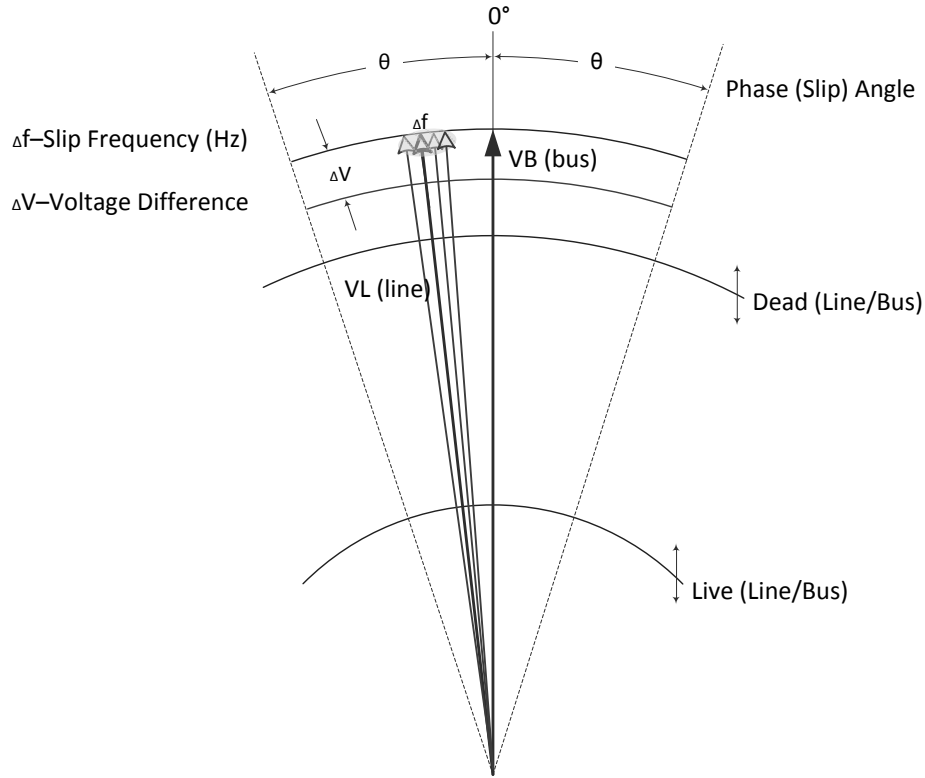

Fig. 1 Synchronization Window

The synchronization window shows the synchronization target, bus voltage  $V_B$  (bus), on the vertical axis. The oncoming generator is  $V_L$  (line), a phasor sweeping clockwise. Settings determine  $\Delta V$ , which is the acceptable difference in voltage amplitude. Settings determine the voltage levels for Dead (DB—dead bus, and DL—dead line) as well as Live (LL—live line, and LB—live bus). Settings also determine the acceptable phase-angle (slip-angle) window,  $\theta$ , in degrees, and the acceptable slip frequency,  $\Delta f$ , in Hz. Slip frequency is the difference between the instantaneous frequencies of both power systems, measured in Hz. A usual setting range for slip frequency is 0.05 Hz to 0.5 Hz. The slip frequency varies instantaneously; the shaded portion of Fig. 1 represents the fast change in the  $V_L$  phasor from the instantaneous slip frequency.

As the oncoming generator output increases, the generator voltage phasor ( $V_L$ ) amplitude increases into an acceptable voltage level dictated by the setting for  $\Delta V$ . The generator speed control advances and retards the angle, denoted by  $\theta$ , of the difference between  $V_L$  and  $V_B$ , until the angle difference falls within the acceptable range. Further, a phase-angle/slip-frequency sync check permits or denies the close command by comparing the instantaneous phase relationship of the two phasors.

An older, less-precise method employed a phase-angle/time approach where a sync-check relay (25) issued a close to the intertie circuit breaker within the window, but without matching phases. This method did not take into account the dynamic, variable nature of the slip frequency (the difference in generator speed, and thus the difference in frequency) which is set by the generator controller. The phase-angle/time approach was valid at one set slip frequency, and intertie circuit-breaker close commands were early or late depending on the rate of change in the slip frequency.

### **C. Live/Live Sync-Check and Dead Closing**

The sync-check function (25) in the purest definition refers only to live-line/live-bus closing (when two sources are active). For any other combination of dead-bus and dead-line closing, a switch is included for the supervisory 25 sync-check relay that bypasses the sync-check function by shorting across the sync-check relay output contacts. This bypass switch closes the sync-check output contacts when there is a need to close the circuit breaker for combinations of dead-bus and dead-line conditions. The switch can be a physical switch, and it can be logical circuitry in the sync-check relay. Often this switch capability for dead closing is called the “voltage monitor.” Settings parameters for voltage levels control the definitions of live and dead, bus and line.

## **IV. Synchronization Methods**

Potential transformers (pts) on the bus side and on the oncoming source (generator) side of the paralleling circuit breaker connect to circuitry (for example: meters, lamps, switches, a protective relay) that indicates and compares the voltage and phase angle relationships of each source. Manual switching, assisted manual switching, and automatic switching are synchronization methods for closing the paralleling (intertie) circuit breaker at the correct moment. Each switching method has related equipment and indicators.

A typical synchronization event begins with applying sufficient excitation to a generator to lock it into synchronous operation. However, the generator is not ready to parallel the power bus to which it will be connected until the criteria for the synchronization window are met. The voltage amplitude and phase angle of the oncoming generator need to be matched to the existing source.

Before switching occurs, operators adjust manual controls, or a synchronizing relay matches the voltage magnitude and the frequency phase angle to place the oncoming generator source within the synchronization window. Then the intertie circuit breaker is closed in the window and the generator is connected in parallel to the bus. There are three methods for synchronizing the source with the bus: manual, assisted-manual, and automatic control.

### **A. Manual Synchronization**

Manual synchronizing is performed by power-plant operating personnel. These personnel control excitation and speed switches to adjust the voltage and frequency of the generator. When the phasors are within the synchronization window an operator closes the intertie circuit breaker to connect the generator to the load bus. This type of synchronizing scheme is simple and economical. Synchronizing meter panels provide information to operators for manual synchronization. Typically, the metering devices include the following:

- Synchroscope
- Indicating lamps (see Fig. 2)
- Separate bus-frequency and generator-frequency meters for matching frequency
- Separate bus and generator ac voltmeters for matching voltage

The synchroscope displays multiple parameters. It shows the slip rate (or slip-frequency rate), revealing whether the generator frequency is running slower or faster than the bus frequency. A dial pointer rotates depending upon the frequency mismatch. The instantaneous position of the pointer indicates the phase-angle difference between the bus and generator voltages. The twelve o'clock position indicates 0-degrees phase-angle coincidence. The goal of synchronizing is to

close the generator/intertie circuit breaker at a 0-degree phase angle to minimize power-flow transients and generator damage when the breaker is closed.

A basic scheme for synchronizing consists of incandescent lamps connected to the same phases on either side of the generator breaker as shown in Figure 2a and 2b.[3] If both the generator and bus voltages are "in phase" there is 0 volts potential difference; the lamps will not be illuminated. This method is known as "dark-lamp" synchronizing.

Another method uses illuminated lamps (called "bright-lamp") along with a dark lamp. By making slight adjustments in the speed of an oncoming generator, the frequency can be equalized so that the synchronizing lamps will light and go out at the slowest possible rate. Because two of the lamps are getting brighter as one lamp is dimming, it is easier to determine the moment for paralleling the sources. In addition, by observing the sequence of lamp brightness, it is possible to know whether the speed of the oncoming source is too fast or too slow.

Although simple, these are a reliable method of synchronization verification. For both methods be sure to have a lamp-test switch to confirm that the lamps are working.

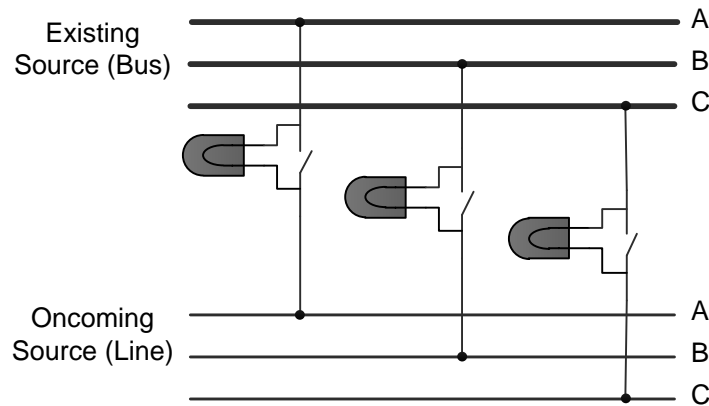

Fig. 2a Dark Lamps

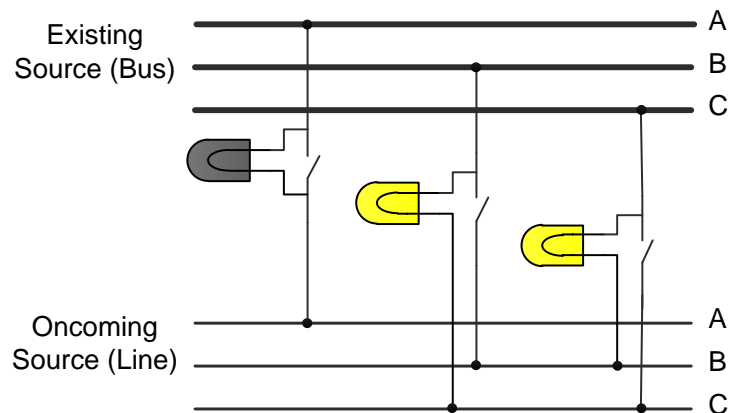

Fig. 2b Two-Bright, One-Dark Lamp

Frequency meters and voltmeters provide a numeric representation of the state of synchronization. When the indicators are connected correctly and are within an acceptable range, then the sources are synchronized.

In practice, for manual synchronization, an operator creates a very slow positive-slip rate by adjusting the generator speed slightly faster than the bus frequency. This positive rate causes the

generator to pick up kW load immediately rather than have the generator operating in a motoring condition when the intertie circuit breaker is closed. Typically, generators are not operated in the underexcited condition (to avoid having the generator consume valuable system VARs (reactive power), and to prevent pulling out of synchronism). Therefore, an operator adjusts the generator voltage slightly greater than the bus voltage, so that a small amount of reactive power is exported from the generator when the circuit breaker is closed. This method also prevents unwanted 32 operations. If closed on the slow side the unit would draw watts (real power) from the system and possibly result in unwanted operation.

### B. Assisted-Manual Synchronization

Adding a supervisory relay, known as a sync-check relay (25), to the manual synchronization process assists with proper synchronization. Manual synchronization with a supervisory relay still requires the operator to control generator voltage and frequency. The supervisory relay enforces a synchronization window for safe conditions that must be in place before the circuit breaker can be closed to parallel the oncoming generator source. The supervisory sync-check relay (25) compares the voltage difference, slip frequency, and phase-angle (slip) differences between the oncoming generator and the station bus. These parameters and some typical ranges are listed in Table 1. (Caution: some relays use an actual-difference–voltage setting, and some relays use a percentage-voltage-difference setting.) The supervisory 25 relay does not allow a circuit breaker close until all of these parameters are satisfied.

Table 1. Typical Sync-Check Parameters

Parameter	Typical Value
Voltage Difference	4–8 V (secondary)
Phase (Slip) Angle	0°–30°
Slip Frequency	0.10 Hz

With modern relays, many set the slip frequency to 0.05 Hz, and the phase (slip) angle to 10° for generator and motor sync check, and at greater parameters for bus-to-bus sync check.

The sync-check relay output contacts are in series with the operator control switch. Circuit breaker closing occurs only when the operator manually closes the switch, and the supervisory relay contacts are closed. Fig. 3 shows the timing of the operator-commanded close and the sync-check-relay close as the voltage phasor approaches 0 degrees.

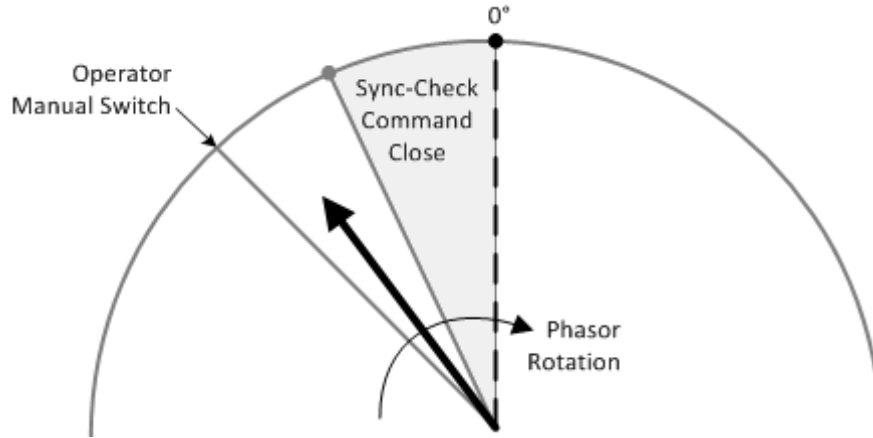

Fig. 3 Assisted-Manual Synchronization with Sync Check

### C. Automatic Synchronization

Manual and assisted-manual paralleling schemes have a shortcoming. These methods require skilled operators at the controls to adjust voltage and frequency to avoid costly damage to equipment caused by improper synchronization. With automatic synchronization, the automatic synchronizer (25A) monitors voltage, frequency, and phase angle. The synchronizer outputs correction signals to a generator governor to achieve voltage matching and frequency matching, and provides the circuit-breaker-close output contact.

Because of the importance of restoring electrical power following an emergency outage, a dedicated automatic synchronizer should be used for each generator, allowing the generators to parallel to each other and to the main bus as quickly as possible. If the automatic synchronizing equipment includes dead-bus switching, one of the generators can pick up the dead bus and start the synchronizing process for the remaining generators. An anticipatory synchronizer is best for this application (see subsection below).

As the prime mover brings the oncoming generator to speed, the generator voltage is applied to the synchronizer. Fig. 4 shows a typical synchronizer block diagram. When the generator input voltage reaches a minimum threshold, the synchronizer begins to sense both the oncoming generator and the existing bus for voltage, frequency and phase angle. The order of operation is the following:

- Compare voltages
- Compare frequency
- Change voltage to match bus
- Change frequency to match bus
- Compare phase angle
- Issue a close command to the intertie circuit breaker (52)

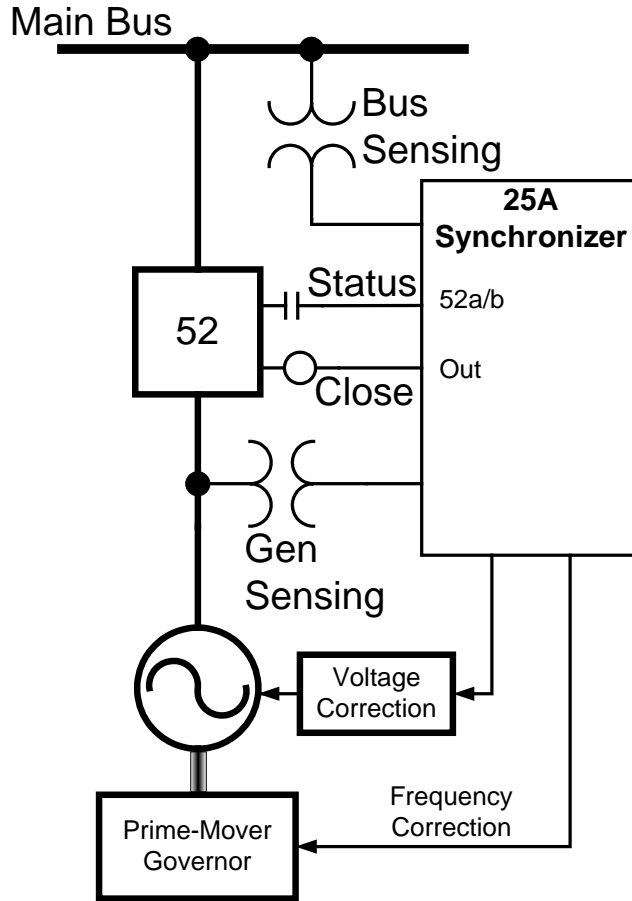

Fig. 4 Synchronizer Connection Diagram

When first applied, the synchronizer senses a large difference between the sources for voltage and frequency. The synchronizer begins to output corrective amplitude voltage signals and corrective frequency signals to the oncoming generator to match it with the bus. The process occurs recursively until the oncoming generator is synchronized with the bus and the synchronizer commands the intertie circuit breaker to close.

The circuit breaker cannot close instantaneously. To achieve circuit-breaker closure exactly at zero degrees, the synchronizer must initiate the breaker-close signal in advance. The circuit-breaker blades close at minimal phase difference. [3]

The autosynchronizer gives the close command while the slip-frequency rate is moving slowly, approaching the zero-degree phase angle. The synchronizer calculates the advance angle, issuing the close command early to compensate for circuit-breaker-closing time. This capability minimizes system transients by closing at zero degrees (at “midnight” on a clock face).

The anticipatory autosynchronizer compensates for the actual breaker closing time plus the output-relay contact-travel time (the time for moving the armature of the physical output relay [6 to 8 ms]). The synchronizer "anticipates" the actual point of synchronism.

The anticipatory synchronizer calculates the advanced angle ( $A_A$ ) that is required to compensate for the circuit-breaker closing time by monitoring the slip-frequency rate and the preset slip-rate value for breaker closing. It also adds the constant of the physical relay contact movement time to complete the calculation. The mathematical relationship is the following:

$$A_A = 360 (T_{CB} + T_R) F_S \quad (1)$$

Where:

$A_A$  is the advance angle, which is the electrical phase angle of the generator with respect to the system bus when the synchronizer initiates a close command

$T_{CB}$  is the circuit-breaker close time. This is the time between the initial application of the close command and the actual contact of the circuit-breaker poles

$T_R$  is the response time of the output relay (6–8 ms)

$F_S$  is the slip frequency

Reducing the advance angle  $AA$  also reduces the absolute value of the slip frequency  $FS$  (which is the maximum permissible speed difference for which a generator is allowed to close onto the bus). Lesser slip frequencies produce less system disturbance and machine damage (known as “softer”).

Larger slip frequencies allow synchronization to be accomplished faster, but there is more system disturbance (“harder”). These considerations should be weighed:

- How fast must the generator be on line?
- How critical is the generator?
- How expensive is repairing/replacing the generator versus the cost of possible outage (down) times?

A proper synchronizer application accounts for these considerations, as well as others that are unique to the system.

## V. The Automatic Synchronizing Process

In the automatic synchronizing process the generator starts, and the synchronizer starts as the generator comes up to speed. As the generator accelerates and approaches the system frequency, the synchronizer commands governor controls for raising and lowering voltage and frequency.

The raise and lower outputs can be set to continuous mode or proportional mode. Continuous mode turns the required logic output on until it is in the synchronization window or overshoots it. Proportional mode toggles the voltage and frequency outputs based upon the calculated error, and on the respective pulse-width and pulse-interval settings. [4]

The voltage monitoring portion of the automatic synchronizer adjusts the voltage regulator to bring the generator terminal voltage within the synchronization window. Next, the phase-monitoring circuitry calculates the advance angle required to close the circuit breaker at a zero-degree phase difference based on the actual slip frequency and on the (preset) circuit-breaker-closing time.

Fig. 5 illustrates the relationship among slip frequency, circuit-breaker-closing time, and the advance angle required prior to closing the circuit breaker at zero degrees.

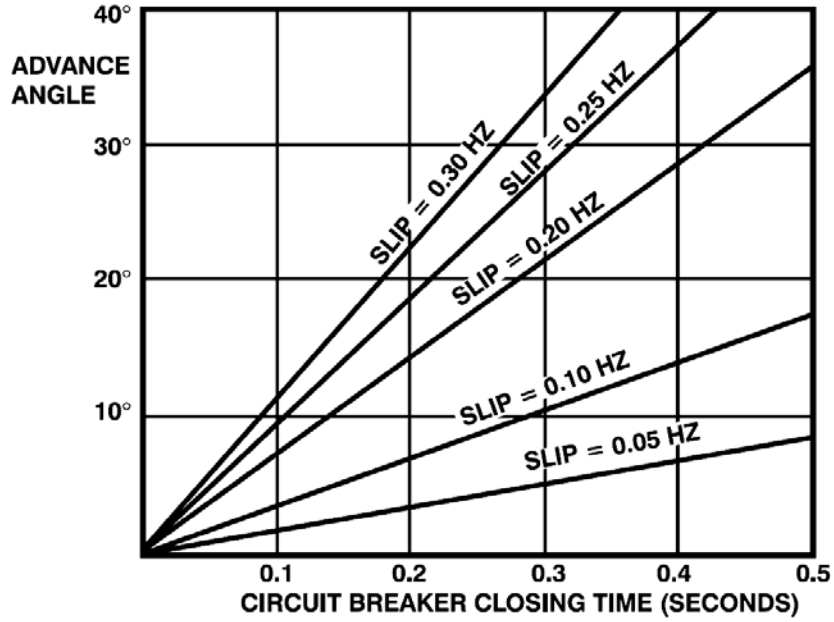

Fig. 5 Sync-Check Closing Quantities

A sync-check relay (25) should be used with the automatic synchronizer (25A) to safeguard the generator circuit breaker from closing out of phase; see Fig. 6. The sync-relay does not allow closing if there is a problem with the synchronization point provided by the automatic synchronizer. [5]

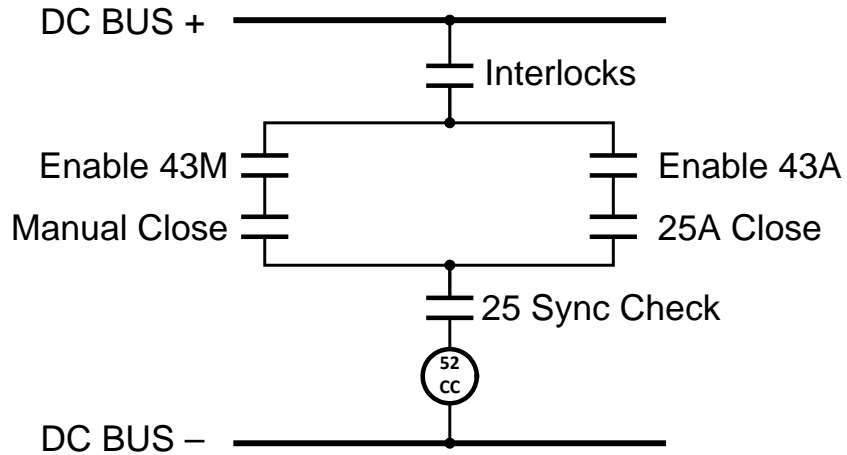

Fig. 6 Supervise Autosynchronizer (25A) with Sync Check (25)

## VI. Applications

Applications for a sync-check relay (25) and an automatic synchronizer (25A) are straightforward. However, experience in the field shows that these applications have circumstances that should be considered.

## A. Sync-Check Applications

The basic sync-check (25) application is shown in Figure 7. A potential transformer (pt) P on the system bus provides bus data to the sync relay. The pt at X provides the line-voltage data on the generator side of the circuit breaker. The sync-check relay (25) monitors these potentials when comparing sources for synchronism check.

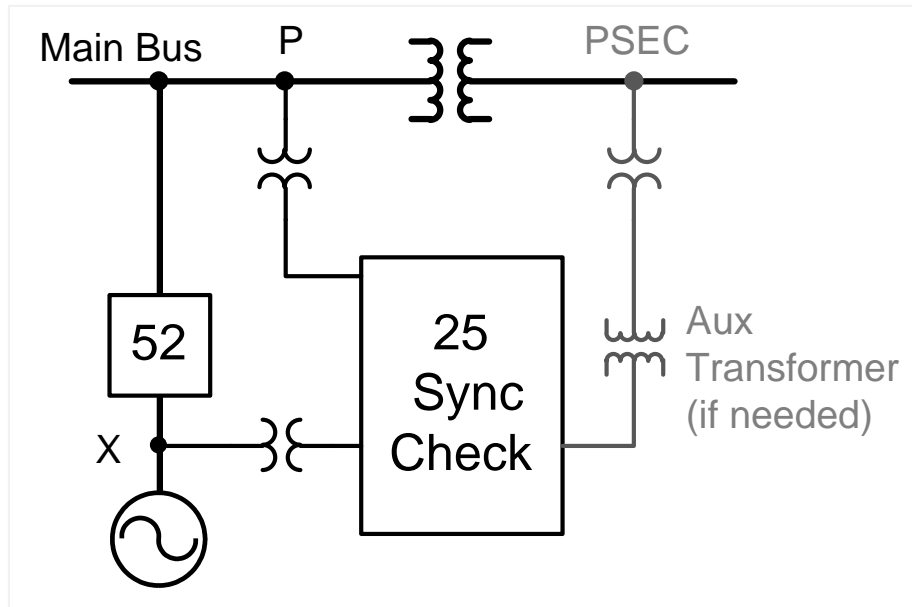

Fig. 7 Typical Sync-Check Connections

It is important to have the same pt connections, or use a method to adjust the relay sync-check inputs. If there is a phase-to-phase connected pt at P, then the pt at PSEC should be a phase-to-phase connection as well. Some modern, numeric (digital) relays offer phase matching as well as voltage matching. Another benefit of modern relays is the enhanced isolation between the sync-check input circuits.

If phase matching and voltage matching are not available in the sync-check relay, then an interposing auxiliary transformer changes phase connection and voltage level. With some sync-check relays this might be necessary when the pt inputs are separated by a wye/delta transformer, as shown at PSEC. Again, a modern, numeric relay can offer phase and voltage matching for this situation.

Today, many generators are impedance grounded to limit damage caused by ground faults. Connecting the pts from phase to ground can give an unreliable voltage level to the sync-check relay because the neutral is offset by the grounding impedance. Phase-to-phase pts should be used for sync-check inputs instead of phase-to-ground signals.[6]

A fast sync-check function makes possible critical applications such as motor-bus transfers. Modern, numeric relays have response time less than one power-system cycle. [7]

## B. Synchronizer Applications

Applying an autosynchronizer depends on the plant and on the operation mode. A standby system requires that the generators are at speed and are closed online quickly. Some applications will tolerate a hard sync in exchange for a fast close (little down time). However, a prime power plant with natural gas generators and/or heat recovery will require a longer time to come online.

In the past an anticipatory automatic synchronizer was expensive to apply to a number of machines on a dedicated, one-to-one basis. A sequencing circuit was used to switch the anticipatory synchronizer from one generator to another. Sequencing a synchronizer adds time to system restoration, as well as complexity to the overall control circuitry.

Today, a dedicated autosynchronizer (25A) is not expensive. By applying a modern protective relay with a built-in synchronizer on a per-machine basis the need for sequencing logic is eliminated. Each synchronizer/governor/generator combination (together with the voltage-regulating equipment) can be optimized for performance and synchronizing speed.

### **C. Breaker-Flashover Protection**

A flashover can occur when a source is synchronizing to an existing power system. As the source voltage on one side of the circuit breaker slips past the bus voltage on the other side of the circuit breaker, there are points where the voltage is 180 degrees out of phase. It is at this point that the voltage difference across the circuit breaker is twice nominal. A destructive flashover can strike if the circuit breaker is not rated sufficiently, or is compromised (there might be a mechanical failure such as an insulating gas leak).

A flashover can damage a generator and the connected generator step-up (GSU) transformer under adverse conditions when voltage stress can be greater than 2 pu. [8] This situation calls for circuit-breaker-flashover detection that initiates breaker-failure protection (50BF) to trip the surrounding breakers to remove the flashover. (Because it is arcing, there is no reason to issue a trip to the already open generator circuit breaker.) Flashover detection monitors phase currents and the 52 close signal, and uses coincidence timers—sensing phase current after the circuit breaker opens.

## **VII. Conclusions**

Power-system operation is improved by applying a thorough understanding of synchronized closing and synchronization. Proper application of the many synchronization methods helps to prevent expensive outages and equipment damage.

Modern sync-check relays (25) match voltage amplitude, frequency, and instantaneous phase angle. Fast sync check makes possible critical main-tie-main applications (such as fast motor bus transfer).

Oncoming generators support power-system loads faster and with less connection disturbance when properly synchronized. These results are achieved by using an anticipatory, automatic synchronizer (25A). This synchronizer issues the close command in advance of the precise synchronization point, adjusting for the circuit-breaker delay, for contact-closure delay, and for varying slip frequency.

Use phase-to-phase pt connections on high-impedance-grounded power systems.

Contingencies should be considered for a failed sync-close attempt. Apply circuit-breaker-failure protection (50BF) when needed to prevent flashover.

## VIII. References

- [1] C37.2, Standard Electrical Power System Device Function Numbers, Acronyms and Contact Designations, IEEE, 2008
- [2] Jonnes, J., "Empires of Light," Random House, 2003, ISBN-10: 0375507396
- [3] Horak, J., "Introduction to Synchronizing," Basler Electric Technical Resource Library, 2005
- [4] Beckwith, T.; "Automatic Synchronizing Considerations and Methods," Western Protective Relay Conference (WPRC), Oct. 1985
- [5] Hartmann, G.; "Automatic Synchronizing for Generation and Tie Lines," Western Protective Relay Conference (WPRC), Oct. 1991
- [6] Thompson, M.J., "Fundamentals And Advancements In Generator Synchronizing Systems," *Protective Relay Engineers, 2012 65th Annual Conference TAMU* , vol., no., pp.203,214, 2-5 April 2012  
doi: 10.1109/CPRE.2012.6201234
- [7] Ransom, D.L.; Chelmecki, C., "Using GOOSE Messages In A Main-Tie-Main Scheme," *Industry Applications Society Annual Meeting (IAS), 2012 IEEE* , vol., no., pp.1,8, 7-11 Oct. 2012  
doi: 10.1109/IAS.2012.6374119
- [8] Wieck, H.; Gutman, I.; Ohnstad, T., "Investigation of Flashover Performance of Snow-Covered Breakers," *Dielectrics and Electrical Insulation, IEEE Transactions on*, vol.14, no.6, pp.1339,1346, December 2007 doi: 10.1109/TDEI.2007.4401216

## IX. Vita

Daniel (Dan) Ransom, P.E., has many years of industrial and utility electronics experience, including protection development and application support. He has been a consulting engineer for power-system protection and for communications systems. Dan is an electrical engineering graduate (BSEE) of Gonzaga University, Spokane, Washington, USA; he also holds a liberal-arts degree from Washington State University in Pullman, WA. He is a Senior Member of the IEEE, with membership in the IAS (Industry Applications), PES (Power & Energy), and Communications societies—he is a working group leader in the Standards Association. To date, he has one US patent. He is a Professional Engineer in numerous USA states. Dan joined Basler Electric in 2010. He is Principal Application Engineer, working in the West region of the United States and Canada.



Highland, Illinois USA  
Tel: +1 618.654.2341  
Fax: +1 618.654.2351  
email: [info@basler.com](mailto:info@basler.com)

Suzhou, P.R. China  
Tel: +86 512.8227.2888  
Fax: +86 512.8227.2887  
email: [chinainfo@basler.com](mailto:chinainfo@basler.com)