

Genset Control and Protection

INTRODUCTION

The purpose of this paper is to examine the fundamental principles of controlling an engine-driven generator set (genset). It will focus on control, protection, load sharing, and integration of the genset into load management and power systems.

NFPA 110 requirements for standby generators and how these requirements can be met with modern electronic genset control devices are presented. In addition, various considerations of paralleled generator sets and implications of paralleling on the engine governor and genset control systems are examined.

TYPICAL GENERATOR SET CONFIGURATION

Generator sets come in a variety of sizes, ratings, and prime mover types and can accept a variety of fuels. Our discussions will focus on the diesel driven genset; however, the concepts can be used for many other types of configurations. We will look at a genset in an emergency standby application that must comply with requirements of the NFPA 110 standard as well as applications where the genset is paralleled to other generators in an island system or paralleled to the utility as distributed generation.

The genset has several main components as noted in Figure 1. The first area of discussion is focused on engine functions and how necessary information is derived to establish appropriate engine protection and control.

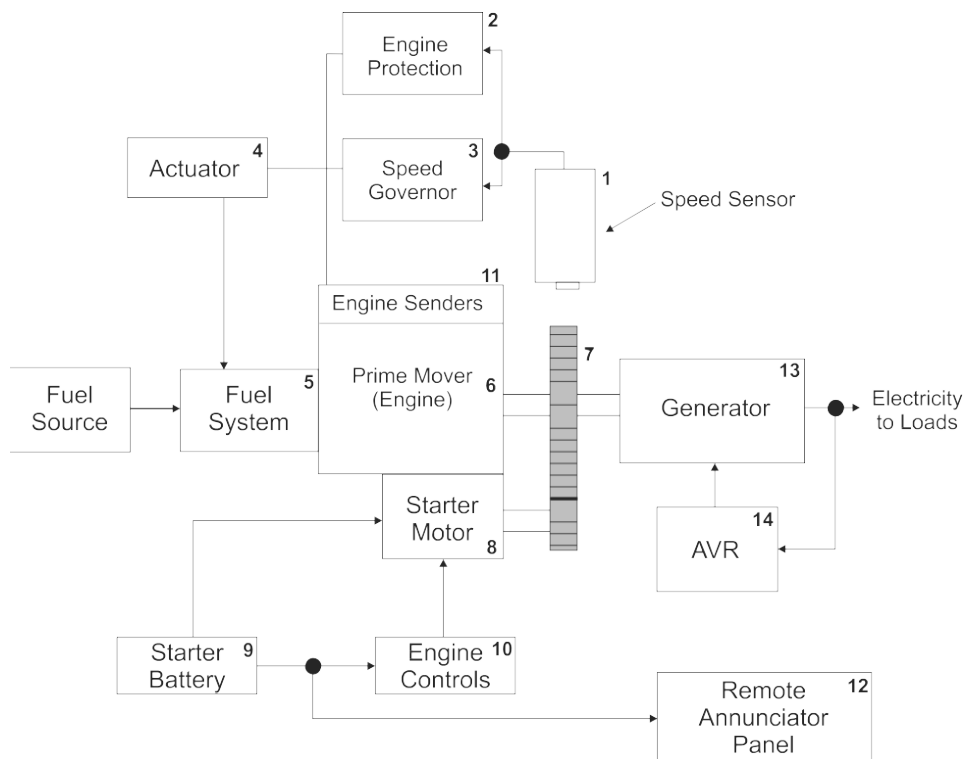

Figure 1: Typical Genset Block Diagram

First, let's examine all of the functional blocks; then we will concentrate on the ones specific to our purposes. Please refer to Figure 1 for the following description.

1. Magnetic Pickup: The magnetic pickup monitors the engine's actual speed by sensing the flywheel teeth.
2. Engine Protection: The engine protection measures engine parameters and ensures the engine is operating within safe operating limits. If the measured parameters exceed the safe ranges, the engine protection will cause an annunciation and shut down the engine when necessary.
3. Speed Governor: The governor determines the actual engine rpm from the magnetic pickup, compares the actual speed of the engine to desired speed, and sends a speed correction signal to the actuator.
4. Governor actuator: The actuator receives the speed correction signal and adjusts the fuel supplied to the engine.
5. Fuel system: The fuel system delivers fuel to the engine, the amount of which is specified by the speed governor.
6. Engine: The engine converts the delivered fuel into mechanical power. Adjustments in the power levels vary the engine speed and/or the amount of electrical power delivered by the genset.
7. Flywheel: The flywheel is coupled directly to the engine and rotates at the same RPM. The magnetic pickup monitors the speed of the flywheel by sensing the passage of flywheel teeth, representing the actual speed of the engine.
8. Starter Motor: The starter motor engages the flywheel and is used to turn the engine at a sufficient speed to start the engine.
9. Starter Battery: The starter battery stores electrical energy to power the starter motor and the necessary engine controls.
10. Engine Controls: Electronic or mechanical controls used to control the engine cranking and protection. On modern engines, the Electronic Control Unit (ECU) is used to control the fuel/air mixture for minimum exhaust emissions.
11. Engine Senders: These devices convert the physical engine parameters (such as oil pressure, coolant temperature and fuel level) into variable resistances for the purposes of metering and protection.
12. Remote Annunciator Panel: The remote annunciator panel provides audible and visual indications of the operational state of the generator set. A remote annunciator panel is a requirement of NFPA 110.
13. Generator: The generator converts the mechanical energy produced by the engine into electrical energy to be provided to the building or utility electrical loads.
14. AVR: The Automatic Voltage Regulator is used to regulate the voltage output of the generator to ensure that the generator's load is provided with the proper voltage level.

DEVELOPING THE VARIOUS ENGINE PARAMETERS



Figure 2: Typical Engine Senders

Magnetic Pickup (mpu)

The magnetic pickup is a variable reluctance sensor which is commonly used as a speed sensor. The mpu senses the flywheel teeth and converts the flywheel teeth movement into an AC voltage signal. An AC cycle is created as each flywheel tooth passes the tip of the mpu.

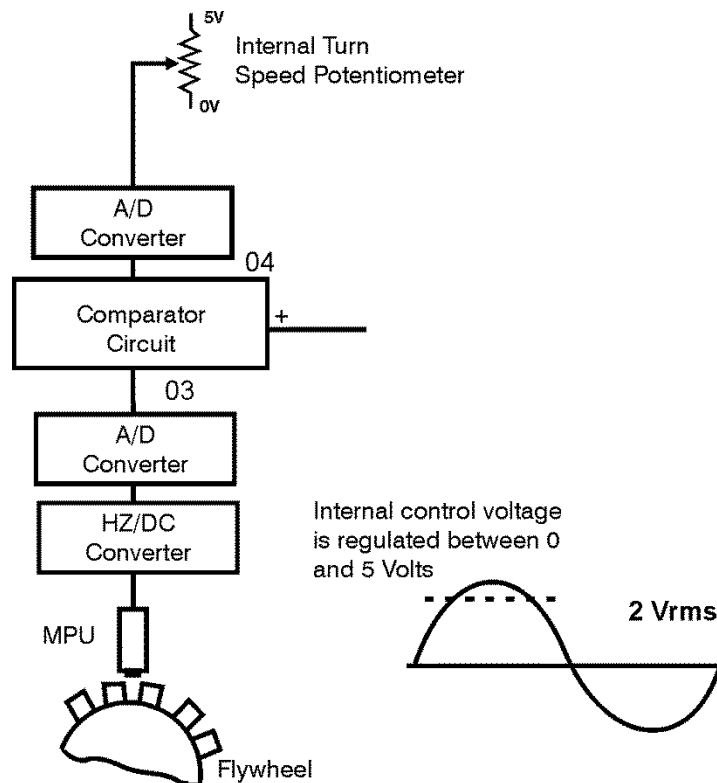

Figure 3: Speed Input to the Comparator

The magnetic pickup consists of a permanent magnet surrounded by a conductor coil like a small generator; thus, there is a magnetic field with north and south poles. As each flywheel tooth cuts through the magnetic field, the magnetic pickup produces an AC voltage cycle. The amplitude of the mpu signal is dependent on the air gap between the mpu and flywheel, the shape and spacing of the flywheel teeth, and the sensitivity of the mpu. The frequency of the mpu signal is determined by the number of flywheel teeth and the speed of the engine.

The governor controller requires a minimum amplitude of 2 Vrms to clear the internal failsafe circuit. The internal failsafe acts as an electronic key to the system, inhibiting fuel flow to the engine until the failsafe receives the 2 Vrms signal. If the engine is running and magnetic pickup voltage decreases below the required level, the fail safe circuit removes power from the actuator, returning the fuel system to minimum. This prevents the engine from operating at potentially unsafe speeds if the signal is too low for the governor to accurately determine engine speed.

The equation for determining the frequency of the Magnetic PickUp output is: $MPU \text{ Hz} = (\text{the number of flywheel teeth} \times \text{engine rpm}) / 60$
This MPU frequency is directly proportional to the engine speed and is used by the governor or engine controller to calculate actual engine speed.

Oil Pressure

The oil pressure sending unit is installed in one of the chambers that circulate lubricating oil throughout the engine. The oil pressure sending unit has a diaphragm that moves based on the pressure of the oil; as the pressure pushes on the diaphragm, the diaphragm moves a wiper on a resistor element, much like turning a knob to move the wiper of a potentiometer. As the resistance varies, the indication of the oil pressure gauge will vary. See Figure 4. The engine controller and/or protection also use this information to provide warnings or shut down the engine if the oil pressure falls below a preset level. This shutdown is intended to prevent engine damage in the absence of sufficient lubricating oil on internal moving parts. The resistance to oil pressure ratio is calibrated by the manufacturer of the sending unit. Oil pressure sending units are available in a variety of maximum pressures and resistance ranges. Therefore, care must be taken to ensure the correct sending unit is used in the system.

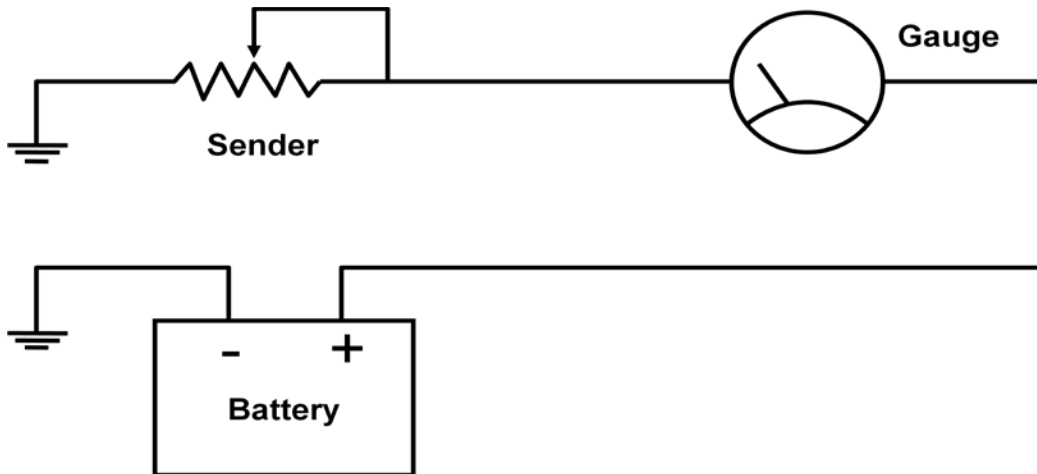

Figure 4: Typical Schematic for engine gauges

Coolant Temperature

The coolant temperature sending unit is installed in the engine water jacket where coolant flows freely. The temperature is converted to resistance via an element that varies changes its internal resistance as a function of temperature. Refer to Figure 4. In the case of a positive temperature coefficient, resistance increases as temperature increases, and resistance decreases as temperature decreases. A sending unit with a negative coefficient responds in the opposite manner: the resistance decreases as temperature increases, and resistance increases as temperature decreases.

Both types of senders are available. Some controllers will allow for either, but care should be exercised to understand the sending unit if a replacement is needed. If the controller does not allow for the sender curve to be programmed (Figure 5), care also must be taken to make sure the replacement sender has the same temperature to resistance characteristic as the original sending unit.

Fuel Sender

Most gensets still use resistive sensors for fuel level measurement, rather than having that information brought into the ECU. The most common form of fuel level sensor is a float attached to a rod that moves a slide up and down on some form of support, changing the electrical resistance as it goes up and down. The controller will then sense the resistance and convert it to a percentage, based on the user's programming.

Programmable Engine Sender Curves

There are many manufacturers of engine senders, and each of them has many sender models with varying characteristics. The differences in the characteristics equate to variations in measurement accuracy for the parameter being measured. Modern genset controllers offer the flexibility to allow the genset assembler to program the characteristics of their engine senders to obtain maximum accuracy. See Figure 5. Because protection for the engine is taken from this input, improvements in protection accuracy also are obtained.

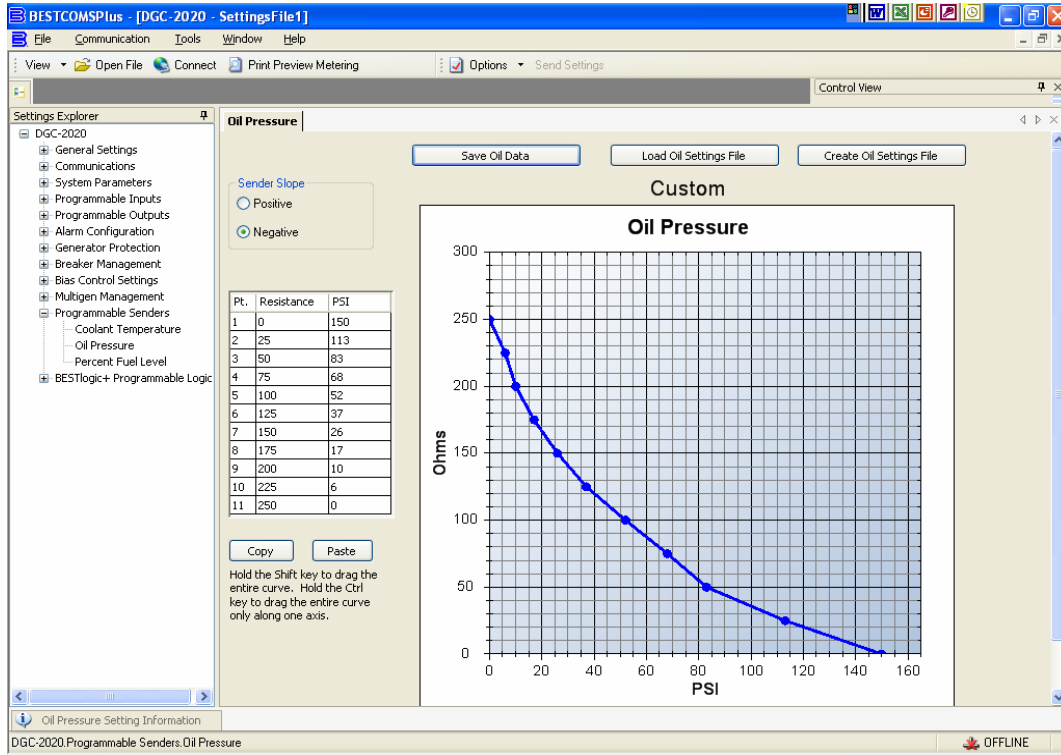

Figure 5: Programmable Sender Curves

ENGINE CONTROL

Starting and stopping the engine

In basic terms, the engine controller is responsible for starting and stopping the genset. A user input (pushbutton, contact input, key switch, or via communications) is given to the genset controller. When the input is recognized by the genset controller, it will energize the fuel solenoid as well as begin the crank cycle. While cranking the genset controller will monitor a signal from the engine, such as the engine speed or oil pressure, to determine that the engine has started at which time it will disengage the starter.

When the engine run input has been removed, a stop input has been given, or a critical parameter is detected outside of its preset operating range, resulting in an engine shutdown, the genset controller deenergizes the fuel solenoid to cut fuel flow and stop the engine.

In order to fully define requirements for cranking, control, and protection for the genset, we must first understand (1) how the genset will be operated, (2) the application requirements, and (3) the power delivery expectations. One way to do this is to classify the generator set by some recognized industry standard or guideline. In emergency standby applications where the generator set provides power to a facility where loss of power could threaten human life, a classification guideline set by the

National Fire Protection Association (NFPA) is applicable. In general, NFPA guidelines offer good practice for standby generator applications whether healthcare related or not.

Depending on the application, satisfying NFPA requirements may be mandatory. The NFPA 110 Standard for Emergency and Standby Power Systems documents many of the requirements for these applications. This paper will address some of the guidelines with regard to the genset controller but is not meant to be all inclusive, as the NFPA 110 Standard addresses many aspects of emergency power supply systems (EPSS).

This focus of this paper is on the engine driven generator as the Emergency Power Supply (EPS). NFPA 110 defines the EPS as, "The source of electric power of required capacity and quality for an emergency power supply system (EPSS), including all of the related electrical and mechanical components of proper size and/or capacity required for generation of the required electrical power at the EPS output terminals".

The function of the EPS is defined as "a source of electrical power of the required capacity, reliability, and quality to loads for a given length of time within a specified time following the loss or failure of the normal power supply".

NFPA 110 can help classify the EPS. The NFPA 110 defines an EPS in three segments: Type, Class and Level.

- *Type*: The type defines the maximum time, in seconds, that the Emergency Power Supply will permit the load terminals of the transfer switch to be without acceptable power.

The types are:

Type U	Basically uninterruptible
Type 10	10 seconds
Type 60	60 seconds
Type 120	120 seconds
Type M1	Manual stationary or nonautomatic - no time limit.

- *Class*: The class defines the minimum time, in hours, for which the Emergency Power Supply is designed to operate at its rated load without being refueled.

The Classes of EPS are listed below:

Class 0.083	083 hours or 5 minutes
Class .25	.25 hours or 15 minutes
Class 2	2 hours
Class 48	48 hours
Class X	Other time, in hours, as required by the application code or user

- *Level*: The NFPA 110 standard recognizes that Emergency Power Systems are utilized in many locations and for many different purposes. The requirement for

one application might not be appropriate for other applications; therefore, the standard recognizes two levels of equipment, installation, performance, maintenance, and testing.

- Level 1 defines the most stringent equipment performance requirements for applications where failure of the equipment to perform could result in loss of human life or serious injuries. All Level 1 equipment shall be permanently installed.
- Level 2 defines equipment performance requirements for applications where failure of the Emergency Power System to perform is less critical to human life and safety and where it is expected that the authority with jurisdiction will exercise its option to allow a higher degree of flexibility than provided by Level 1. Level 2 equipment shall be permanently installed.

Prime Mover Starting Equipment

Starting the engine is most frequently accomplished using an adequately sized electric starter system with a positive shift solenoid to engage the starter motor. The motor cranks the prime mover for a specified time at a speed recommended by the engine manufacturer at the lowest ambient temperature anticipated at the installation site. NFPA 110 can be used as a guideline to determine proper starting equipment.

Cranking Cycles

A complete cranking cycle consists of a crank period of approximately 15 seconds duration followed by a rest period of approximately 15 seconds. See Figure 6. The maximum number of Crank/Rest cycles is three. After the third cycle, an overcrank alarm will be given. Generators of 15kW and lower shall be permitted to use continuous cranking where desired. Upon engine start the crank cycle will cease. Two methods of rpm detection shall be implemented for redundant determination of engine start and crank cycle termination.

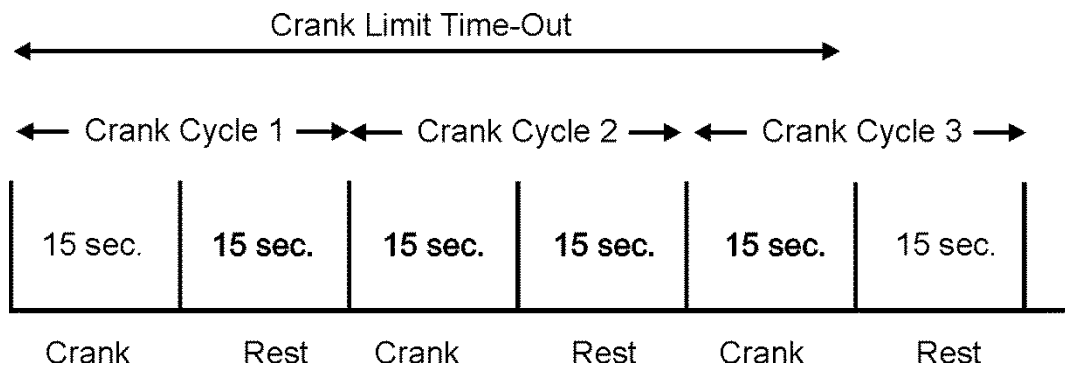

Figure 6: Crank/Rest Cycles

The following table illustrates Level 1 and Level 2 starting requirements.

	Level 1	Level 2
a. Battery Unit	X	X
b. Battery certified	X	O
c. Cycle cranking	X or O	O
d. Cranking limiter time (sec)		
Cycle crank (3 cycles)	75	75
Continuous crank	45	45
e. Float-type battery charger	X	X
1. DC ammeter	X	X
2. DC voltmeter	X	X
f. Recharge time (hr)	24	36
g. Low battery voltage alarm contacts	X	X

LEGEND: X= Required O= Optional

The batteries and charging system are sized to provide sufficient power to the DC system.

CONTROLS / PROTECTION

This section identifies and describes control and protection as specified by NFPA 110. Control panels that meet these requirements are approved for Level 1 and Level 2 installations.

The automatic control and safety panel is to provide automatic restart, run-off-auto switch, shutdowns, alarms and controls. The panel is to be part of the Emergency Power System and possess the following characteristics:

- Cranking control and cycling, as previously described.
- A panel mounted control switch marked "Run - Off - Automatic".
 - Run: Manually initiates the start and run of the prime mover.
 - Off: Stops the prime mover, resets the safeties or both.
 - Automatic allows the prime mover to be started by closing a remote contact and to be stopped by opening the remote contact.
- Controls to shut down and lock out the prime mover under the following conditions:
 - Failing to start after specified cranking time (overcrank).
 - Overspeed.
 - Low lubricating oil pressure.
 - High engine temperature.
 - Operation of remote manual stop station.
- Battery powered individual alarm indication to be annunciated visually at the control panel for pre-alarm and shut downs indicated in the following table. There will be additional contacts or circuits for a common audible alarm that

signals both locally and remotely when any of the specified conditions occur. A lamp test switch shall be provided to test the operation of all alarm and warning lamps.

- Controls must shut down the engine upon removal of the initiating signal or manual emergency shutdown.
- The automatic control and safety panel shall house the ac instruments listed.

Engines equipped with a maintaining shutdown device (air shutdown damper) shall have a set of contacts that monitor the position of the device, with local alarm indication and remote annunciation in accordance with the following table.

Indicator Function (at Battery Voltage)	Level 1			Level 2		
	C.V.	S.	R.A.	C.V.	S.	R.A.
a. Overcrank	X	X	X	X	X	O
b. Low water temp. < 70°F(21°C)	X		X	X		O
c. High engine temp. prealarm	X		X	O		
d. High engine temp.	X	X	X	X	X	O
e. Low lube oil pressure prealarm	X		X	O		
f. Low lube oil pressure	X	X	X	X	X	O
g. Overspeed	X	X	X	X	X	O
h. Low fuel main tank	X		X	O		O
I. EPS supplying the load	X			O		
j. Control switch not in Auto position	X		X	O		
k. High battery voltage	X			O		
l. Low voltage in battery	X			O		
m. Battery charger ac failure	X			O		
n. Lamp test	X			X		
o. Contacts for local and remote common alarm	X		X	X		X
p. Audible alarm silencing switch		X			O	
q. Low starting air pressure	X			O		
r. Low starting hydraulic pressure	X			O		
s. Air shutdown damper when used	X	X	X	X	X	O
t. Remote emergency stop		X			X	

KEY:

C.V= Control panel mounted visual indication.

S= Shutdown of Emergency Power System. (EPS)

R.A= Remote audible

X= Required O= Optional

Additional requirements

1. Item (o) shall be provided, but a separate remote audible signal shall not be required when a regular annunciated worksite is staffed 24 hours a day.
2. Item (b) is not applicable for combustion turbines.
3. Item (q) or (r) applies only were applicable as a starting method.
4. Item (i): EPS ac ammeter shall be permitted for this function.
5. All required C.V. functions indicated in the R.A. column also shall be annunciated by a remote, common audible alarm.
6. Item (h) on gaseous systems shall require a low gas pressure alarm.

Engine protection can be as simple as a switch installed directly in the engine which trips when a certain pressure, temperature or level is reached. This type of protection is not adjustable, and the installer must select the correct switch to ensure proper engine protection.

Another way to protect the engine and provide indication of a desired engine parameter is with a gauge with an internal contact. In this case, there is an adjustable post or stop that is one side of the contact, and the indicating needle of the gauge is the other side of the contact. When the needle makes contact with the post, the circuit is completed and the contact closes. See Figure 7.

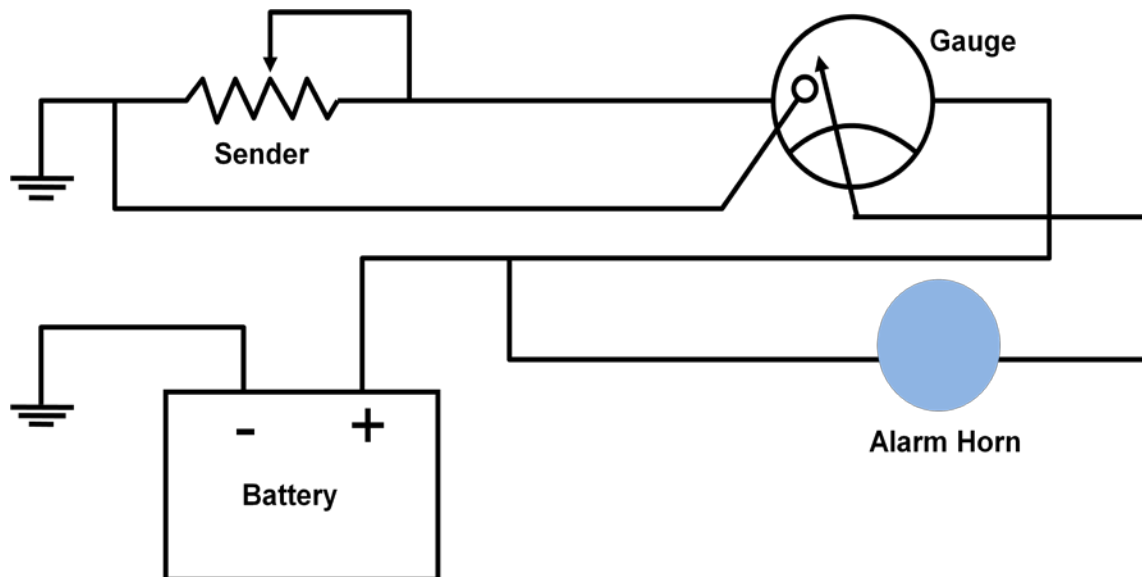

Figure 7: Gauge with an internal switch

In modern electronic engine controls (see Figure 8), the sending unit is connected to the controller and the controller displays the desired parameter. It also provides user definable set points for alarms and pre-alarms which can drive contact outputs to the genset system to facilitate annunciation and/or tripping.



Figure 8: Digital Genset Controller, DGC-2020

To further enhance the protection of the genset, additional inputs are available. By employing temperature sensors in the engine and generator, today's genset controllers provide added protection. RTDs may be placed in the generator windings and bearings to allow protection and provide early warning of winding overheating or potential bearing wear out. Installing thermocouples in the exhaust stream can warn of engine related problems.

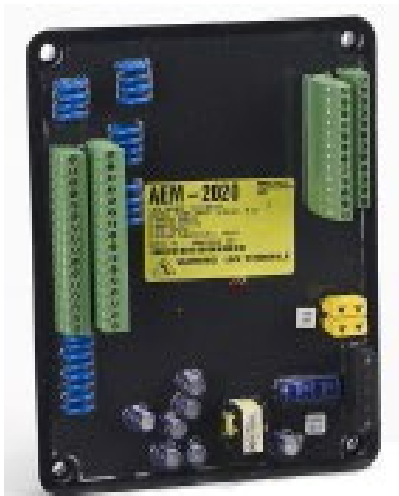

Figure 9: AEM-2020
(Analog Expansion Module)



Figure 10: CEM-2020
(Contact Expansion Module)

A module such as the AEM-2020 (Figure 9) can be connected and used with the DGC- 2020 to assign multiple over and/or under thresholds with time delays for each of the RTD and thermocouple inputs. This module also provides eight (8) additional analog inputs, which allow for monitoring, control, and protection of other parameters throughout the DGC-2020 control scheme. The analog inputs accept a 4-20mA or ± 10 Vdc input from transducers to monitor and protect the genset from conditions such as excessive vibration, temperature, kW, or any other analog parameter.

Because the AEM-2020 can be mounted remotely from the DGC-2020, the assembler can limit the amount of wiring between the RTD, thermocouple, or transducer and the AEM. This minimizes EMI noise issues as well as installation and material costs. Communication is fast and allows the user to program and monitor the various parameters that the AEM-2020 is configured to accept.

If additional inputs and/or outputs are required in the protection and control scheme, devices such as the CEM-2020 (Figure 10) can be added. The CEM-2020 provides ten (10) contact inputs as well as up to 24 form C contact outputs. The additional I/O is configured using the DGC-2020's fully programmable logic. Not only can the additional I/O be used as engine protection via user configurable alarms and pre-alarms, but programmable logic can be designed to perform functions normally performed by external devices. This can result in lower system costs by eliminating external relay control logic or PLCs.

The following figures (11 through 13) illustrate how simple it is to incorporate these modules into the protection and control schemes of the DGC-2020.

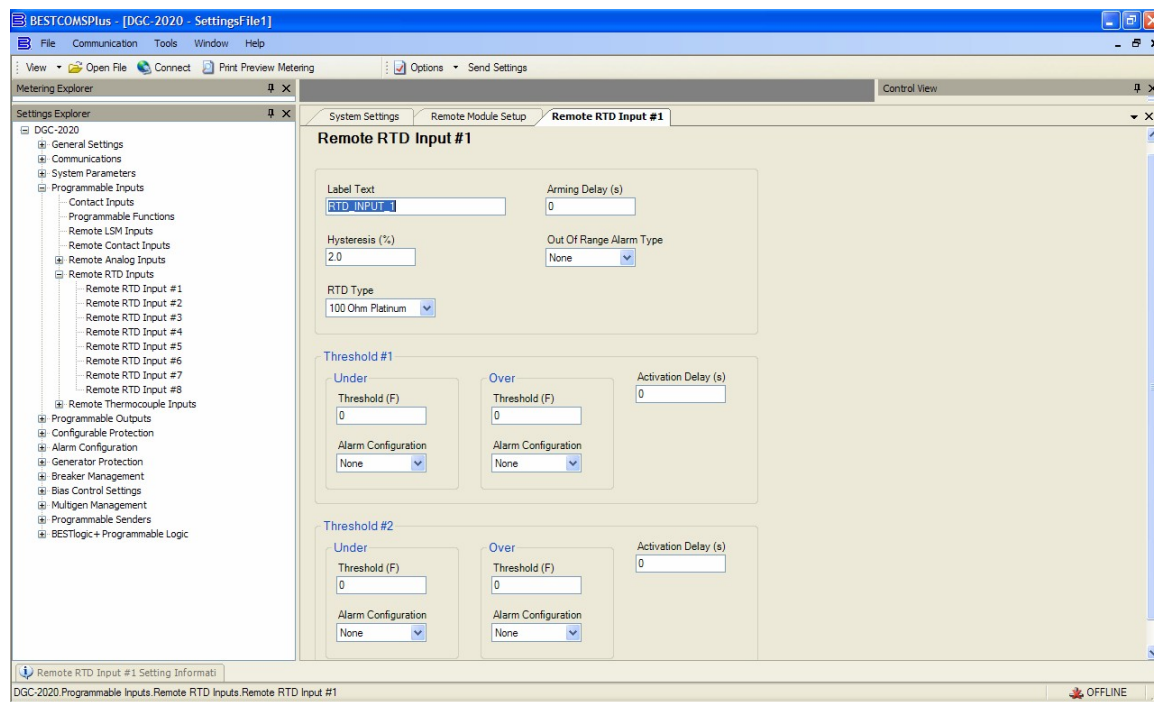

Figure 11: AEM-2020 Configuration Screen

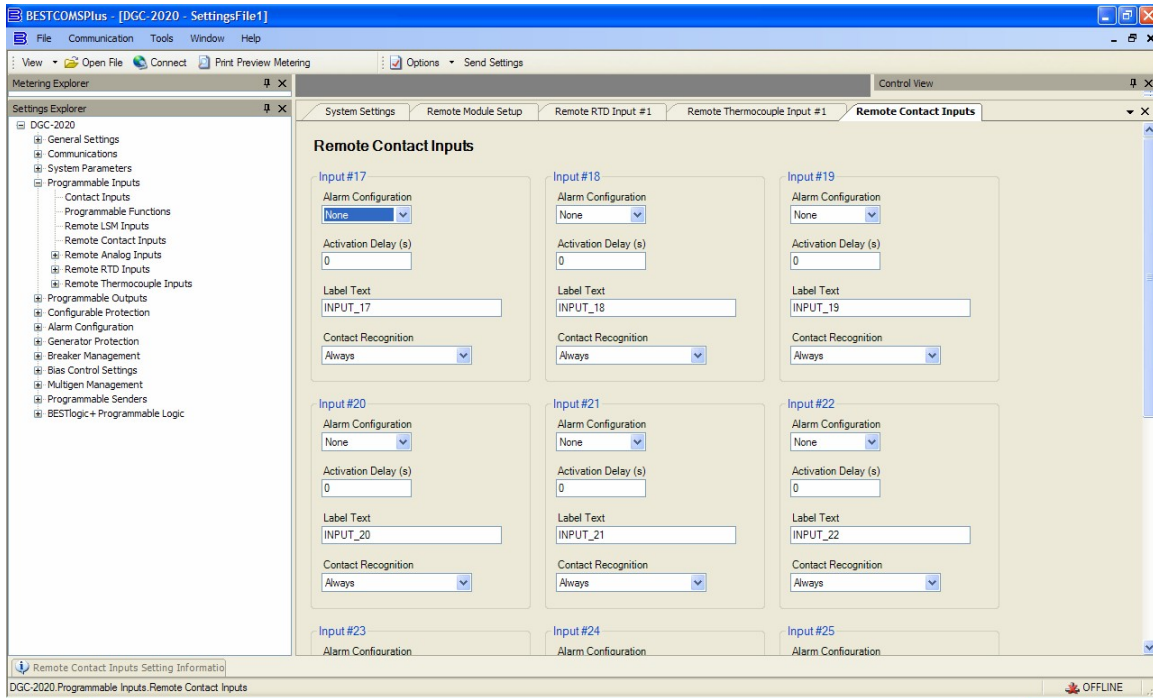

Figure 12: CEM-2020 Configuration Screen

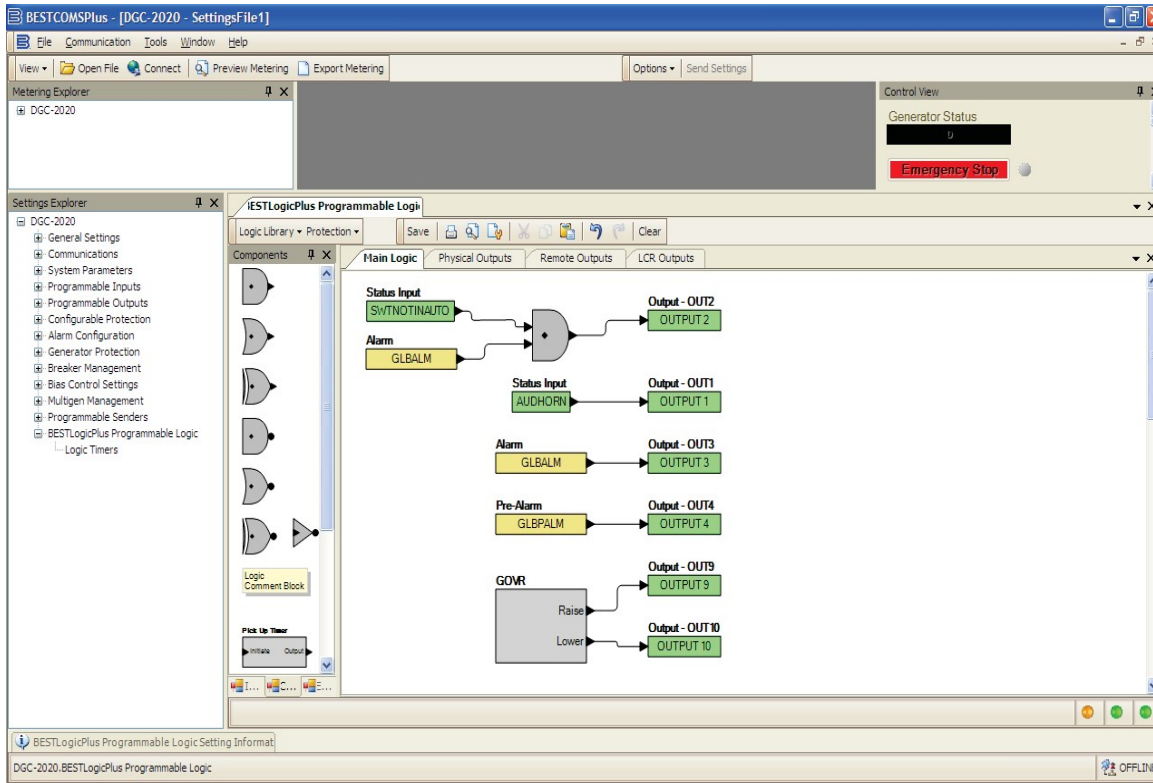

Figure 13: DGC-2020 Programmable Logic

REMOTE CONTROLS AND ALARMS

As part of the NFPA requirements, a common remote audible alarm powered by the storage battery is provided. This remote alarm is located outside the Emergency Power Supply service room at a worksite readily observed by personnel.

An alarm silencing means is provided, and the panel includes repetitive alarm circuitry so that, after the alarm has been silenced, it is reactivated after clearing the fault condition and must be restored to its normal position to be silenced.

In lieu of the above requirement, a manual alarm silencing method to silence the audible alarm after the occurrence of the alarm condition is permitted, provided such means do not inhibit any subsequent alarms from sounding the audible alarm again without further manual action.

It should be noted that the majority of this information came directly from the NFPA 110 standard, and it is not the intent of this document to replace the NFPA standard. The NFPA 110 standard should be referred to when designing an Emergency Power Supply system.

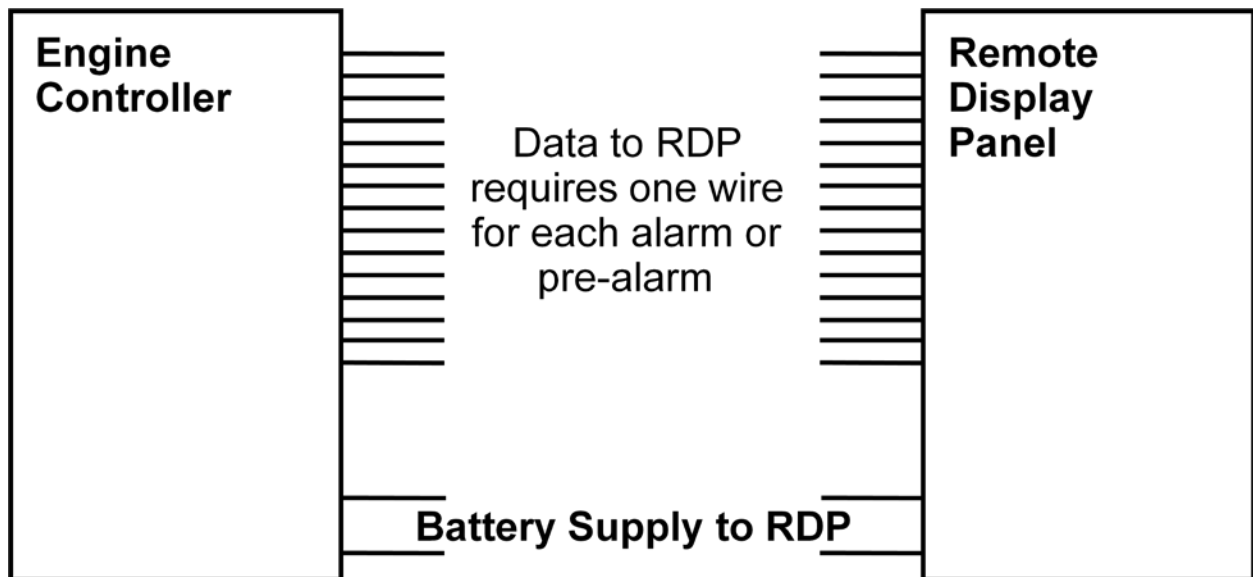

Figure 14: Conventional Remote Display for NFPA 110

There are several methods for meeting the NFPA 110 remote display panel requirements. In conventional remote display technology, the display utilizes a wire connected from the controller to the remote display for each alarm or pre-alarm that must be annunciated to comply with NFPA 110 requirements. When combined with the wires for battery voltage to supply the display, the installer could pull up to 15 wires just for remote annunciation. See Figure 14.

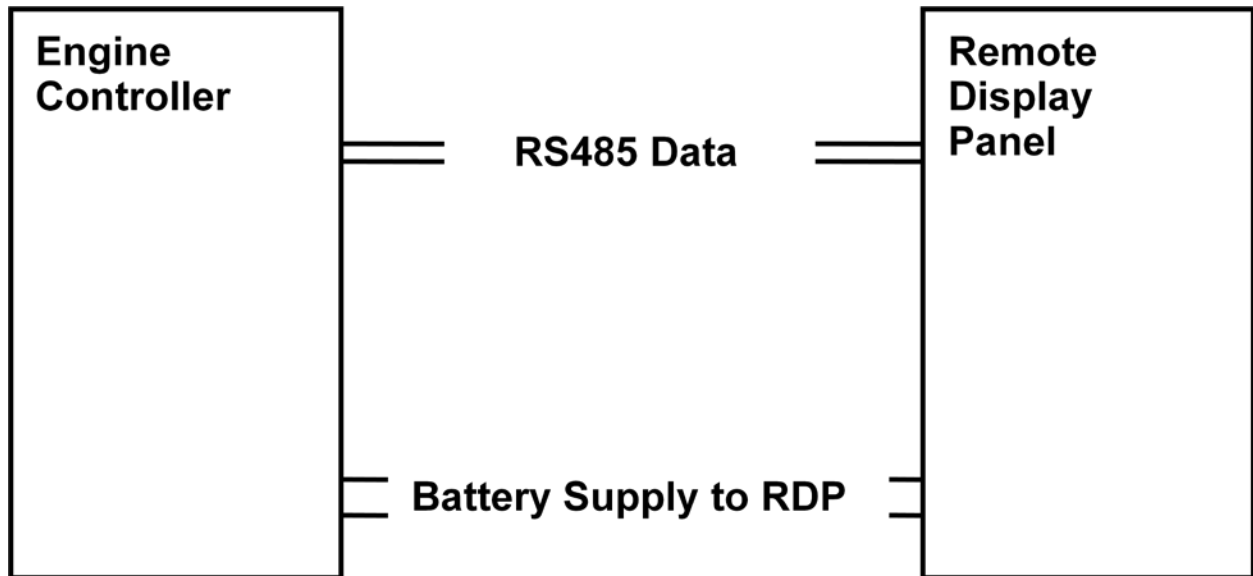

Figure 15: Communications Remote Display for NFPA 110

There is another way to accomplish the same annunciation with only 4 wires. Today's technology allows us to communicate up to 4000 feet from the controller using RS 485 communications (Fig 15). Data can be transmitted via common or custom protocols with only two wires. The remote display panel (Fig 16) translates the data sent from the controller and displays the appropriate messages. This is a significant advantage to the installer who only has to pull four wires instead of 15.



Figure 16: Remote Display Panel

GENSET CONTROLS and SAE J1939 CAN BUS COMMUNICATIONS

Now that the basic functions of the engine controller have been defined, the focus of this paper will shift to modern engine controls that are present on "electronic engines".

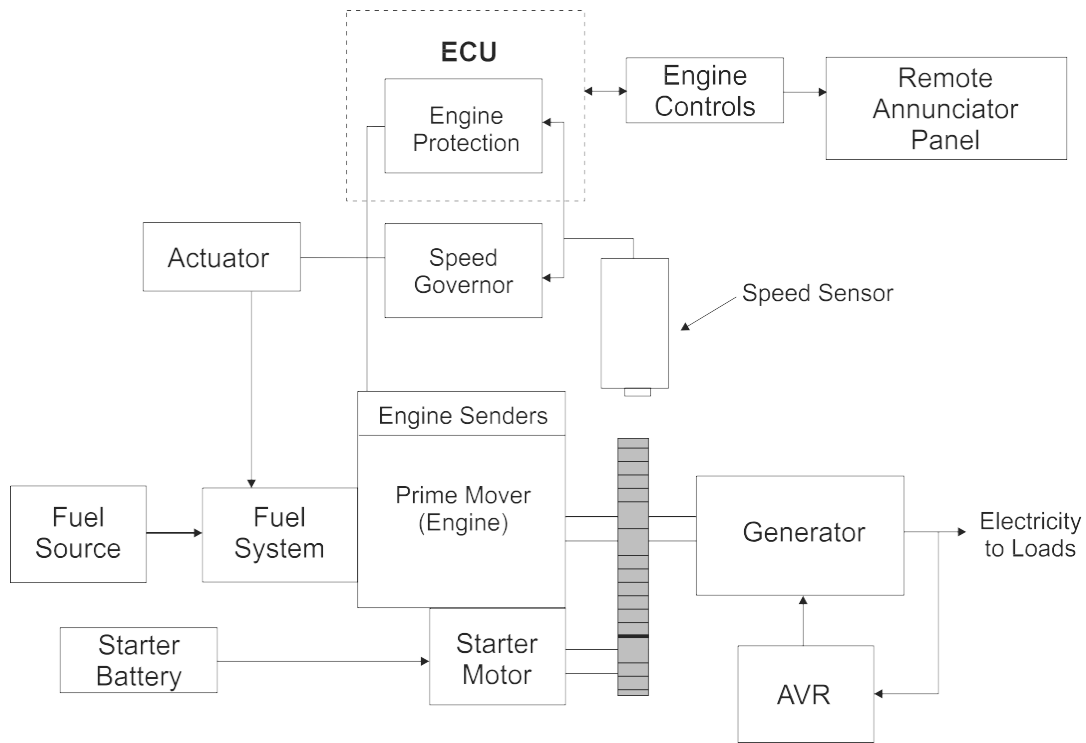

Figure 17: Typical Genset with ECU Equipped Engine

EPA Mandates

Over the years, the EPA has imposed many emission standards to limit the amount of pollutants emitted from diesel engines in an effort to improve air quality. Although these limits on pollutants, such as hydrocarbons (C_xH_2) and nitrogen oxides (NO_x), began with over the road trucks, they are now being imposed on off road diesel engines. Diesel engines used on farm tractors, excavators, logging equipment, boats and gensets are included in these regulations.

Engine manufacturers are able to comply with EPA standards by precisely controlling the amount of fuel and air going into the engine's combustion chambers. They can precisely control the fuel with electronically controlled fuel systems calibrated for the machine. These fuel systems incorporate on board computers called Electronic Control Units (ECU) that monitor many of the engine's fuel and operating parameters to, in turn, limit the quantity of pollutants going into the atmosphere.

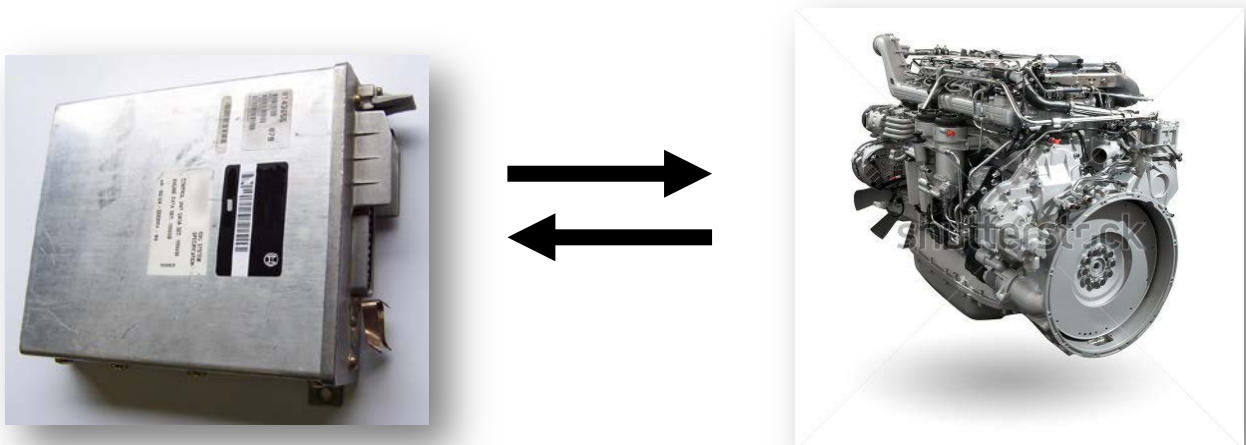

Figure 18: ECU/Engine Communication

Engine manufacturers have developed very sophisticated controls within the engine that monitor every aspect of engine operation including load levels, environmental conditions, and any other parameters that impact emission levels. Because so many sensors and transducers need to monitor all the variable parameters of the engine, a high speed communication network communicating via a common protocol between these modules and the ECU had to be developed.

The Society of Automotive Engineers (SAE) developed a communication protocol to standardize communication among the engine, the truck manufacturers and manufacturers of the transducers. The primary standard used for communications among the devices is SAE J1939. This standard and the data transmitted to and from the ECU is the focus of this section.

SAE J1939

A Control Area Network (CAN) is a standard interface that allows communications among multiple controllers and electronic devices on a common network using the SAE J1939 message protocol. The SAE J1939 defines the message size and type. It standardizes the communications for virtually any machine, although it also provides the manufacturer with the flexibility to include unique proprietary messages. The message configuration is shown in Figure 19.

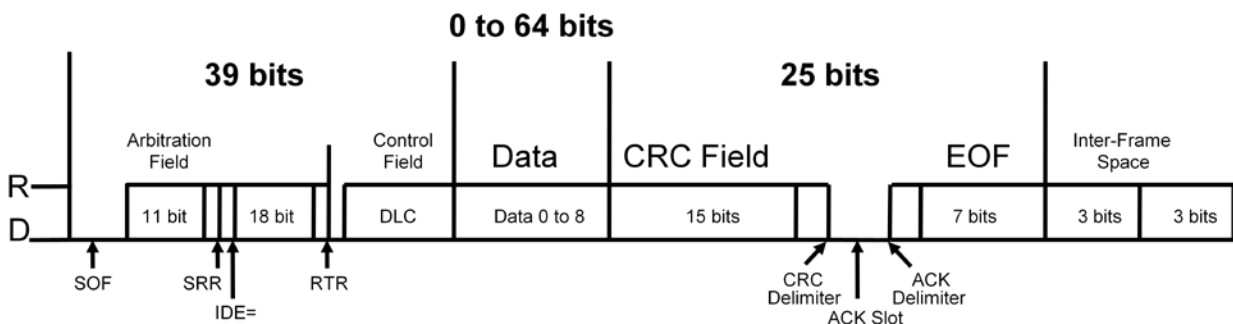

Figure 19: Message Configuration

The CAN interface allows the ECU and the genset controller to communicate with each other. The ECU reports the engine operating information to the genset controller following the J1939 Protocol allowing the genset controller to make full use of the information available from the ECU. In some cases the genset controller can issue commands to start and stop the engine over CAN bus. Sophisticated genset controllers such as the DGC-2020 utilize this information to provide a superior metering and protection scheme compared to what is available on a system using analog senders.

Advantages of ECU Controlled Engines

When an engine equipped with an ECU is received by the genset assembler, all of the information needed to control and protect the engine is resident in the ECU; thus, there is no need to spend time and money mounting and wiring additional sensors. The basic information required by the controller is oil pressure, coolant temperature, and engine speed. With CAN bus communications, this information is available via the ECU and eliminates the need for additional oil pressure senders, coolant temperature senders, and magnetic pickups. This is advantageous to the assembler because it offers increased efficiency and lower installation costs. Only the "plug and play" CAN bus connections are required for the genset controller to properly perform its protection and control functions.

Accuracy of Metering

Many engines equipped with CAN bus have the ability to provide the information in the ECU to a handheld or PC-based diagnostic tool. A service technician can use the diagnostic tool messages to evaluate and troubleshoot the engine. If the information from the ECU is compared to the genset controller, it will be identical provided the genset controller also is using CAN bus to derive its information. But if the genset controller uses separate senders and is not communicating via CAN bus to the ECU, discrepancies in the metering can and probably will occur due to the inconsistencies of the senders. These differences in the metering can lead the technician to believe something is wrong, and additional inefficiencies can be created in the commissioning, troubleshooting, and maintenance of the genset. When the genset controller gets its information from the ECU, it agrees with the diagnostic tool, reducing the possibility of confusion for the technician.

Expanded Display Capability

Because the ECU needs to monitor many engine parameters for emission control purposes, it contains a wealth of information not formerly available on the genset controller. Using communications from the ECU, we can display virtually any information resident in the ECU on the front panel of the genset controller. The following is a list of some of the available parameters:

Throttle Position	Percent of Load	Actual Percent Torque
Injection Control Pressure	Injector Metering Rail Pressure	Trip Fuel
Total Fuel Used	Fuel Temperature	Engine Oil Temperature
Engine Intercooler Temp	Fuel Delivery Pressure	Engine Oil Level
Coolant Pressure	Coolant Level	Fuel Rate
Barometric Pressure	Ambient Air Temperature	Air Inlet Temperature
Boost Pressure	Intake Manifold Temperature	Air Filter Differential Pressure
Exhaust Gas Temperature	Battery Potential	Engine Configuration

Additional Engine Configuration information about the ECU is available through the genset controller. Engine Configuration information includes:

- (10) Engine speed and Torque settings
- Gain (Kp) of the end speed Governor Reference
- Engine Torque
- Max Momentary Engine Overspeed
- Max Momentary Override Time Limit
- (4) Speed Control Range Settings

Diagnostics and Troubleshooting

Diagnostic Trouble Codes (DTCs) are part of the SAE J1939 CAN bus communications protocol. These codes provide detailed information about the type and severity level of a problem. These problems may be as simple as a clogged fuel or air filter, a high cylinder temperature, or something more problematic.

DTCs include coded diagnostic information that includes Suspect Parameter Numbers (SPN), Failure Mode Identifier (FMI), and Occurrence Count (OC) information. All parameters have an SPN that is used to identify the items for which the diagnostic code is being reported. The SPN specifies the parameter that is being reported (“oil pressure”, for example). The FMI defines the condition detected in the subsystem identified by the SPN (“Parameter within valid operating range but low -> most severe”, for example). The problem may not be a failure but a subsystem condition that needs to be reported to the technician or operator. The OC contains the number of times a fault or condition has previously occurred (see Figure 20).

The DTC, FMI and OC information is available on the front panel of the DGC-2020 via the LCD display (see Figure 20).

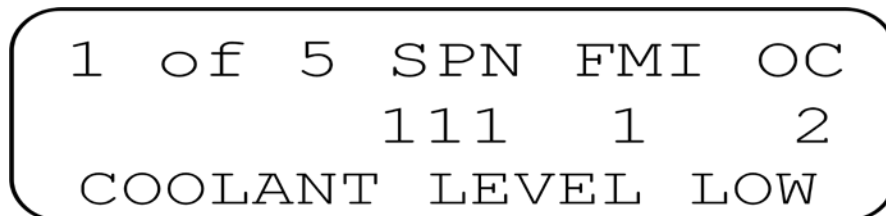

Figure 20: Typical DGC Front Panel DTC Display

The information displayed on the front panel can be cross referenced in the engine manufacturer's manual. The information displayed on the screen in this example means:

- "1 of 5" This refers to the first DTC of five being displayed.
- "SPN 111" This SPN is cross referenced to "Coolant Level".
- "FMI 1" FMI 1 = "Data Valid But Below Normal Operating Range → Severe".
- "OC 2" OC 2 means the SPN- FMI combination has occurred twice before.

“Coolant Level Low” is the descriptive text associated with SPN-FMI combination.

DTC information also is available in the DGC-2020 BESTCOMSPi^{us}® PC software.

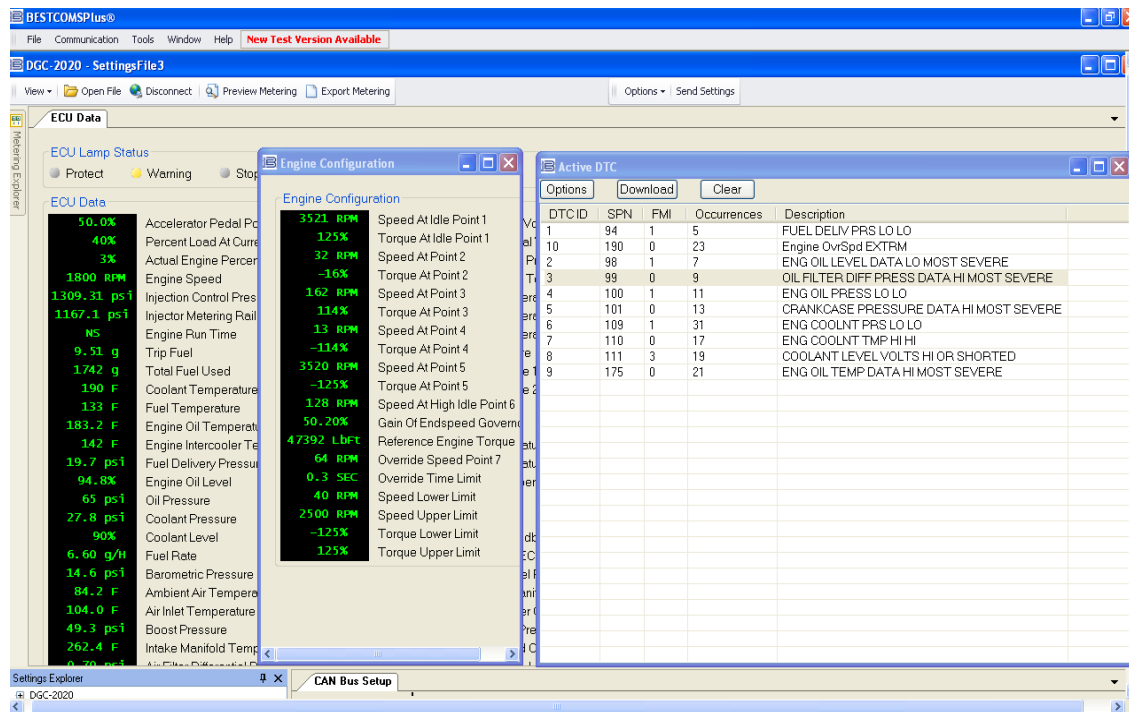

Figure 21: Typical PC Screen Showing DTC Information

Remote Troubleshooting

If there is a problem with a remote genset hundreds of miles from the maintenance firm, a maintenance engineer can call the site and establish communication to a modern genset controller and interrogate the engine before leaving the shop. By using a modem, phone line, or Ethernet connection to communicate with the genset controller, the technician can gather the ECU's diagnostic data before leaving the shop, allowing formulation of a repair plan before making the service trip.

The BESTCOMSPi^{us}® PC software screen shown in Figure 21 illustrates the information available via the J1939 CAN bus Protocol. The PC, working with the genset controller, and ECU equipped engine provides intuitive information for the user. Both Active and Previously Active DTC information is available on the screen. With these, the

technician may be able to develop a history of the engine's performance and problems to develop a repair plan.

Using the DTC example previously discussed, the technician can pull the DTC information via communication with the genset controller to determine there is an issue with coolant level, understanding the failure mode before leaving the shop: *There is a coolant leak on the engine*. The technician will know to take a new hose, extra hose clamps, and enough coolant to refill the radiator to fix the problem. This information could save additional trips to and from the site, which can save maintenance costs and limiting genset down time.

Tier 4i and Tier 4 Final EPA Requirements

Diesel exhaust contains soot and dangerous nitrogen oxide (NO_x), a pollutant created during combustion that contributes to acid rain. In 1996, the EPA began to implement steps to reduce pollutants from diesel driven engine generator sets. In 2015, the campaign will conclude with the implementation of Tier 4 Final. Controllers are affected by standards related to the reporting of new parameters being generated from the engine ECU. The primary concerns are related to with exhaust after treatment systems placed on engines to control exhaust gases and particulate content; the controller must now report status of the exhaust after treatment systems.

There are two types of exhaust after treatment systems: Diesel Particulate Filter (DPF) and Selective Catalytic Reduction (SCR) systems. DPF filters reduce the amount of particulate matter (e.g. soot) held in the exhaust. When the soot increases to a certain level, a regeneration cycle, consisting of operation at elevated exhaust temperatures, must be initiated to burn off the accumulated particulate matter.

In addition to the DPF, the exhaust may be treated in an SCR system prior to being released into the atmosphere. The SCR system injects urea-based diesel exhaust fluid (DEF) into the exhaust stream to initiate a chemical reaction to change nitrogen oxides into less harmful substances, such as water. The DEF is held in tanks that must be refilled periodically.

The genset controller must be capable of receiving the status of the exhaust treatment systems from the engine ECU and alerting the user of system status and when to add DEF, initiate a DPF regeneration cycle, or take other necessary action.



Figure 22: TIER 4i EPA Symbols in the DGC-2020

Remote control

Gensets equipped with modern genset controllers can provide remote monitoring and control for the user. With remote access, a unit can be started, stopped, configured,

synchronized, loaded, unloaded, and troubleshot from anywhere in the world.

The controller can be set up to notify the user of virtually any condition from major trouble to something minor like low fuel. These messages can be sent to a pager, cell phone, email, or to a host PC. The operator can access the controller by dialing in via a phone line or by accessing the genset controller over ethernet to identify the genset's status and/or control its operation. All of this can be done as if the operator is at the front panel of the genset controller.

Genset controllers such as the DGC-2020 offer options for RS-485, Ethernet and on-board modems as methods of remote communication. These options allow for communicating to the genset controller from across the room or around the world. They give users full ability to monitor, control and troubleshoot *from anywhere*.

Governor Control

The governor control is a closed loop system (Figure 23). The governor receives speed information from a speed sensor and drives an actuator controlling fuel flow to the prime mover to maintain constant system speed.

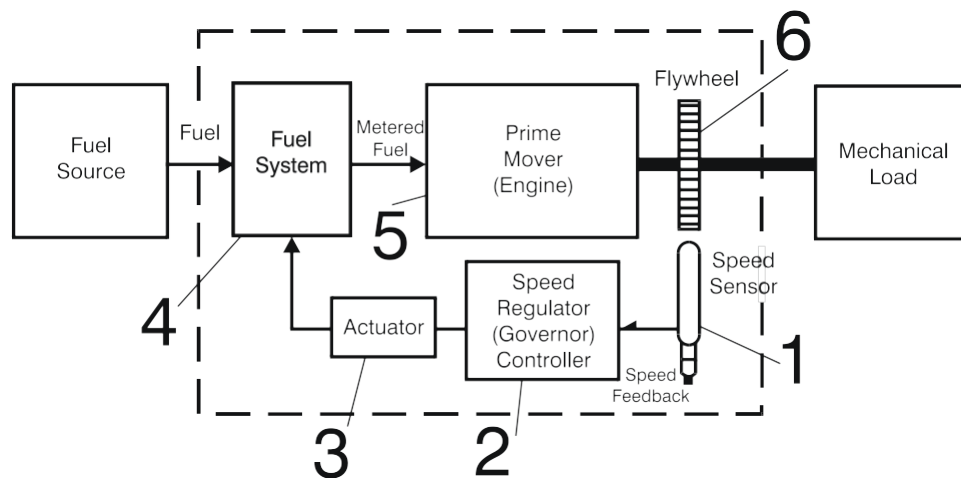

Figure 23: Speed Control Loop

On a reciprocating engine, the governor control system consists of a speed sensor, speed reference, comparator, gain circuit and a driver for the fuel system (Figure 24).

Typically, the speed sensor is a magnetic pickup installed along the edge of the flywheel. The output of the magnetic pickup is an AC voltage generated by the passing flywheel teeth which is proportional in frequency to the engine rpm. The comparator circuit receives this signal and compares the measured engine speed to the speed reference. If the comparator circuit detects that actual speed differs from the reference setting, the comparator generates an error signal that is passed through the gain circuit. The output of the gain circuit is a correction signal which is subsequently conditioned to act as a drive signal for the actuator, moving the actuator to increase or decrease fuel to correct the speed error.

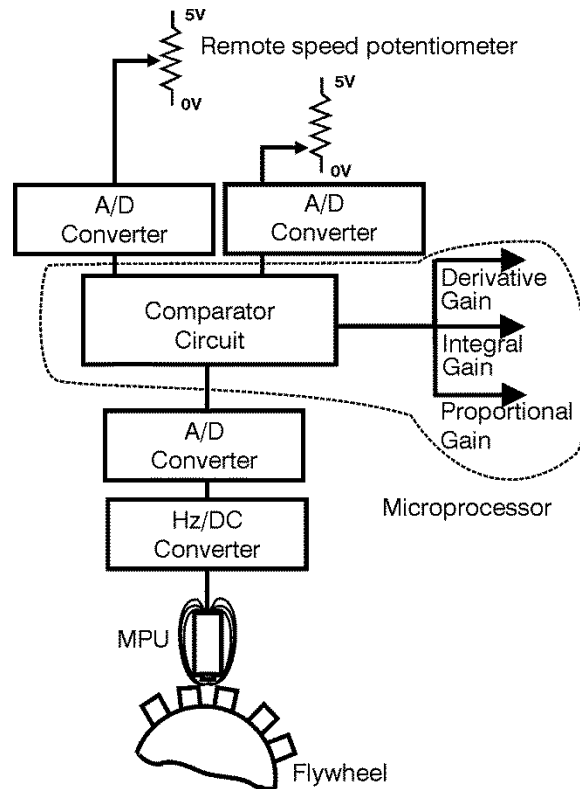

Figure 24: PID Gain Circuits in Governor

The gains are set to optimize engine performance and match the dynamics of the governor to the engine it controls. For instance, if a governor is tuned to respond faster than the engine, the system is unstable and it will hunt. If the governor is tuned more slowly than the engine, system performance may be sluggish and not respond well to changes in engine load.

In an engine system, the actuator controls the amount of fuel delivered to the engine. The actuator can be considered as a valve controlled by current. Actuator drive signals are commonly pulse width modulated waveforms which modify the pulse width to vary the current through the actuator, subsequently modifying the actuator position, to control the amount of fuel delivered to the engine. Narrowing the pulse widths decreases the current and reduces fuel flow. Widening the pulse widths increases the current, increasing fuel flow which, in turn, increases engine speed.

The actuator drive switches very rapidly (Fig 25), changing the average current by varying the ratio of on time to off time; the current through the actuator is proportional to this ratio. When considering the on-off switching of the signal, it might seem that the output of the actuator would be jerky or unstable. However, the average current that results has a much slower response than the typical 200 pulse per second switching signal, resulting in smooth actuator current to create a stable output response.

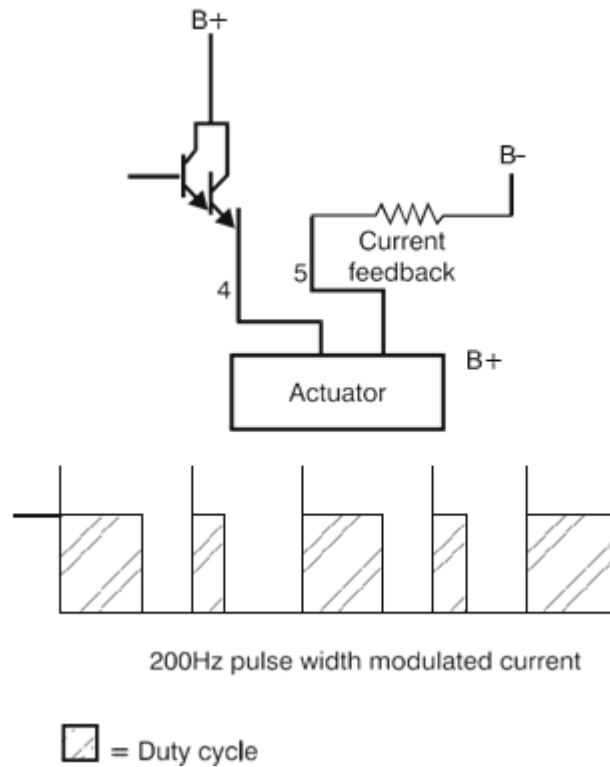

Figure 25: Actuator Drive Output

Similar concepts apply to most other types of prime movers, with differences in the manner of speed sensing and adjustment of fuel flow. For example, in a system employing a hydraulic turbine, speed control is achieved by controlling the flow of water, the pitch of the turbine blades, or a combination of the two. Gas and steam turbines use similar means to control and adjust the flow of fuel to the turbine. In power generation applications, the objective of this control loop is the same regardless of the type of prime mover: adjust the flow of fuel to maintain constant speed.

Paralleling Generators

Sometimes the load covered by a single generator is increased beyond the generator's capacity. For an example, when a new wing is added to a facility, the standby generator may not have the capacity to supply the increased building load. In such a case, the options are (1) replace the generator with a larger one, or (2) add another generator which can be operated in parallel with the first to supply the increased load.

Often, there is a cost advantage where two small generators are lower in cost than a single larger machine. Another benefit of paralleled machines is redundancy in the system. In the event one generator fails to start, critical loads may be supplied by the remaining unit. At times multiple generator systems are designed with N+1 redundancy. If a load requires N generators, N+1 machines are installed. If one fails to start or is out of service, the remaining N generators can supply the entire load.

A diagram of two generators operating in parallel is shown in Figure 26.

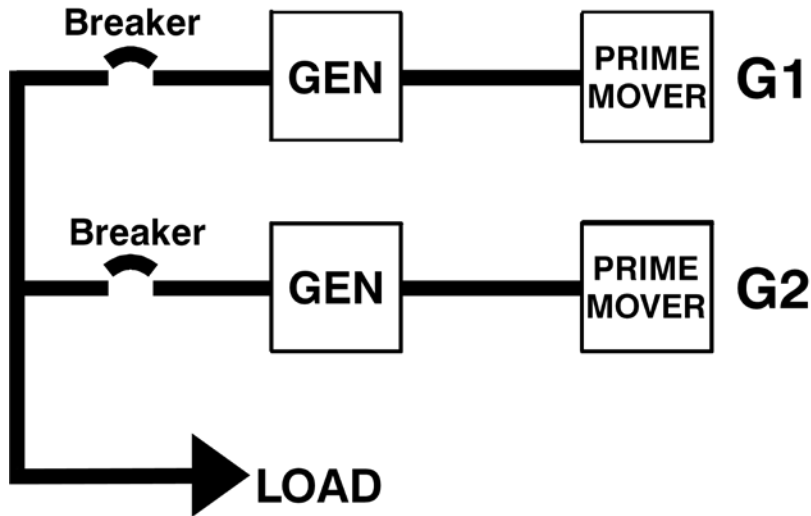

Figure 26: Islanded Generator Bus

The complexity of multiple generator installations increases compared to that of a single machine, creating a number of issues to consider. First, when multiple generators operate in parallel, there must be a means of matching the voltage and phase angle of the machines prior to paralleling. This process is known as synchronization.

A second consideration is that when generators are paralleled, it is necessary to add a mechanism for each governor control to accomplish sharing of load among the machines. If not implemented, when generators are connected to a common bus, each generator's governor will attempt to regulate speed based upon its speed reference and measured speed. In real life, no two governors are set exactly the same. A unit with a speed reference set higher than the average system speed attempts to increase the speed of the machine by increasing fuel to the prime mover. A unit with a slower speed setting than the actual system speed attempts to slow the system by reducing fuel. However, because the machines are locked into synchronism, there is no speed difference between them. The result is unbalanced power flow where the faster machine increases power output, and the slower machine decreases power output. Eventually, the faster machine takes the entire load and may cause power to flow into the slower machine. This flow of power into the slower machine is known as motoring. In the end, the slower machine may go into a reverse power situation and/or an overload condition could occur on the faster machine.

Automatic Synchronizing

An automatic synchronizer (Fig 27) may be added to match generator voltage, speed, and phase angle to a bus automatically without operator intervention. To allow for fully automatic operation, the function of an automatic synchronizer must be a part of the generator control system. In some cases, an automatic synchronizer is added to the control system in the form of a standalone device. However, more sophisticated genset controllers have an integrated synchronizer function which can be enabled and programmed as an integral part of the control system.

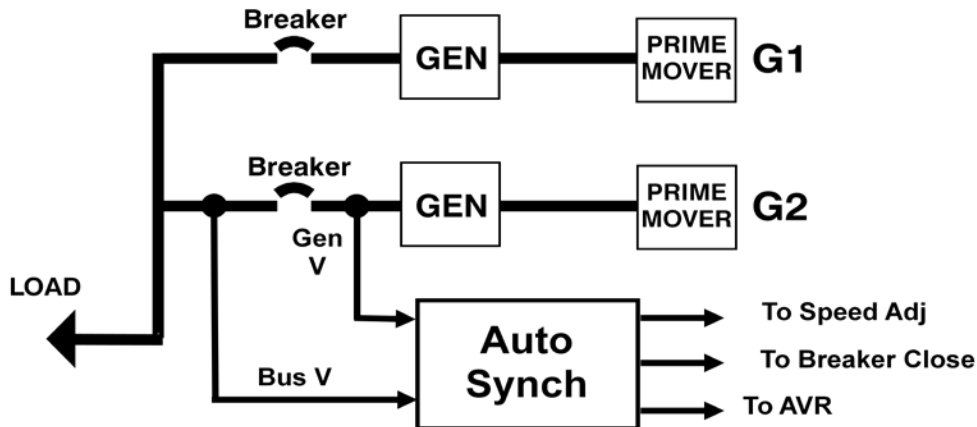

Figure 27: Addition of Auto Synchronizing

The automatic synchronizer carries out four tasks: (1) match generator voltage to bus voltage, (2) match generator frequency to bus frequency, (3) match generator phase angle to bus phase angle, and (4) when these conditions are met, close the generator breaker to connect the generator to the bus. After these tasks are complete, the synchronizer is disabled until the next time a breaker closure to a live bus is required.

Selection of an automatic synchronizer must be made based upon compatibility with the speed governor and excitation control system in order for the synchronizer to do its job effectively. The interface to the governor and voltage regulator may be in the form of analog signals, typically a 4-20mA current or a 0-10Vdc voltage. Another common interface is dry contacts to raise and lower the set point of the governor and voltage regulator. Most modern controllers can accommodate either of these methods. Communication of bias information over CAN bus is a third method of bias control for some governors or engine ECUs and regulators.

The type of synchronizer is selected based upon system considerations and the operator's preferred style of operation. Some prefer a phase lock style of automatic synchronizer, while others may prefer an anticipatory style of operation. Each type has operational advantages. The phase lock style of synchronizer controls the voltage, frequency and phase angle of the generator and drives it into a predetermined voltage and phase angle window. When the generator voltage and phase angle are within the window for a predetermined time delay, a closing signal is given to the generator breaker.

The anticipatory style of synchronizer controls the generator's voltage to drive the generator voltage to match that of the bus. The generator frequency is driven so that a fixed, well controlled slip frequency is achieved relative to the bus. An advanced breaker closing angle is calculated based on the breaker closing time and the slip frequency of the machine. The breaker close signal is given at a precise moment in advance of 0 degrees slip angle, achieving generator breaker closure at 0 degrees slip angle between the generator and bus. This is the point where the machine experiences the least amount of mechanical stress.

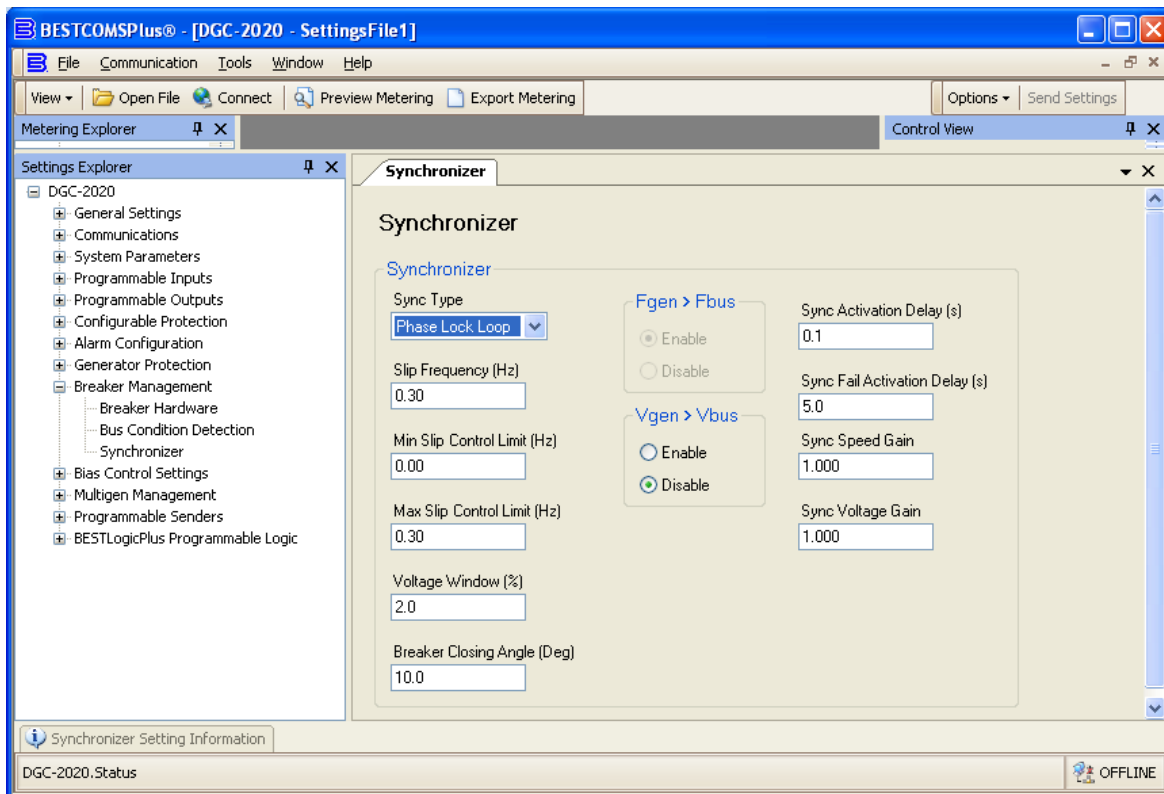

Figure 28: Synchronizer Settings (BESTCOMSPPlus®)

If rapid synchronization is a primary goal, the phase lock style of synchronizer is often chosen. If it is desired to export kW when the breaker first closes, anticipatory synchronization is utilized where the slip frequency is such that the generator speed is slightly faster than the bus speed.

Standby Generators and Mains Failure

A standby generator system is employed when a facility cannot afford to be without power during a utility power outage. A ten (10) second maximum time between loss of utility and standby generation on powering the load is a common requirement in life critical applications. Extremely critical applications may require the use of spinning backup generation. In these systems, a phase lock style automatic synchronizer keeps the generator in synchronism with the utility at all times, but the generator breaker remains open until a utility failure is detected. When a disruption of utility

power occurs, the utility tie breaker is opened and a signal is sent to close the generator breaker, placing the load on the generator. Because the automatic synchronizer has maintained synchronism with the utility, a very fast transition to the backup generation is possible with minimal disturbance to the system.

Other applications may not need to operate as quickly. In these applications, the genset controller can detect that the utility bus voltage has dropped or has been removed and immediately initiate a start command to the generator set. When the generator has been started and is stable, the controller initiates a breaker close command to power the load.

In the same situation with multiple generator sets available, all machines can be set to detect a failed utility bus and start the generators. Inter-genset communications are used to determine which generator is the first to reach stability and close the breaker to support the load. In this case, the inter-genset communications are critical to ensure that only one genset closes to the dead bus and other machines are not closed together out of phase. After the first machine has closed onto the generator bus, the remaining machines can be synchronized to the generator bus as required.

Parallel Operation of Islanded Generators

When multiple generators are tied together on a common bus that is not connected to utility power, where the generators are the only power source, the system is referred to as an "islanded system" (Fig 29).

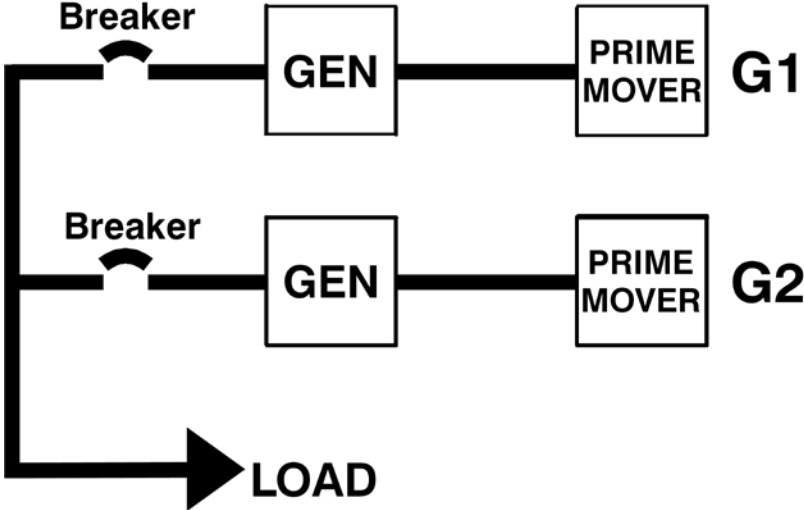

Figure 29: Islanded Generator Bus

As discussed previously, when generators are paralleled, it is necessary to add a mechanism for each governor control to accomplish sharing of load among the generators. If not implemented, when the generators are connected to a common bus, each generator's governor attempts to regulate speed based the speed it measures, and its internal speed reference setting. Because no two governors are exactly the same when the units are paralleled, the system speed is the average

speed of the individual machines. The faster governor raises its output in an attempt to increase speed, whereas the slower governor lowers its output, attempting to reduce speed. The result is that one unit takes the entire load and may begin motoring the other unit.

In load sharing systems, a Load Share Control mechanism is added to the system which provides positive or negative speed bias to the system governor to achieve load sharing between the machines. To measure real power (Fig 30), the speed governor can use the sensed voltage and current from the generator and the governor actuator position to adjust the speed set point in proportion to the load. One common load sharing mechanism is to reduce speed of a generator system with increasing real power load. This type of operation is known as speed droop. Speed droop has been employed for many years in power generation applications.

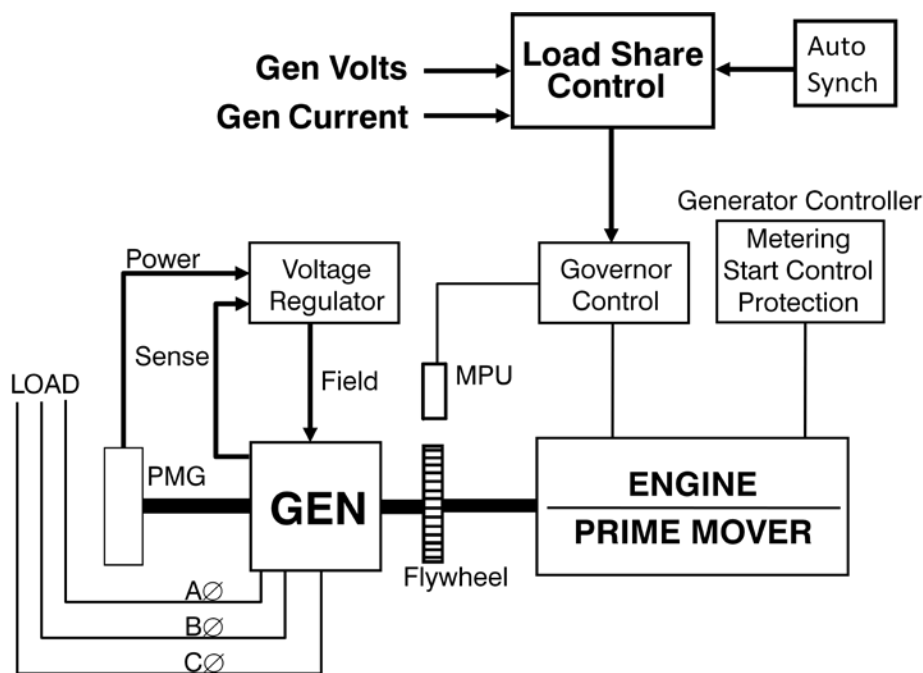

Figure 30: Paralleled System Controls

Figure 31 shows a speed droop characteristic depicting the relationship between machine power output and machine speed in speed droop implementations. At no load, the engine runs at its speed set point. As the load increases the speed drops off. When the machine is at rated load, the speed is reduced by a percentage of rated machine speed. The percentage of reduction is known as the droop percentage. If a change from no load to full load results in a 5% decrease in the speed setting, the unit is set for 5% speed droop. With the speed droop adjusted properly, paralleled generators share the load equally among them.

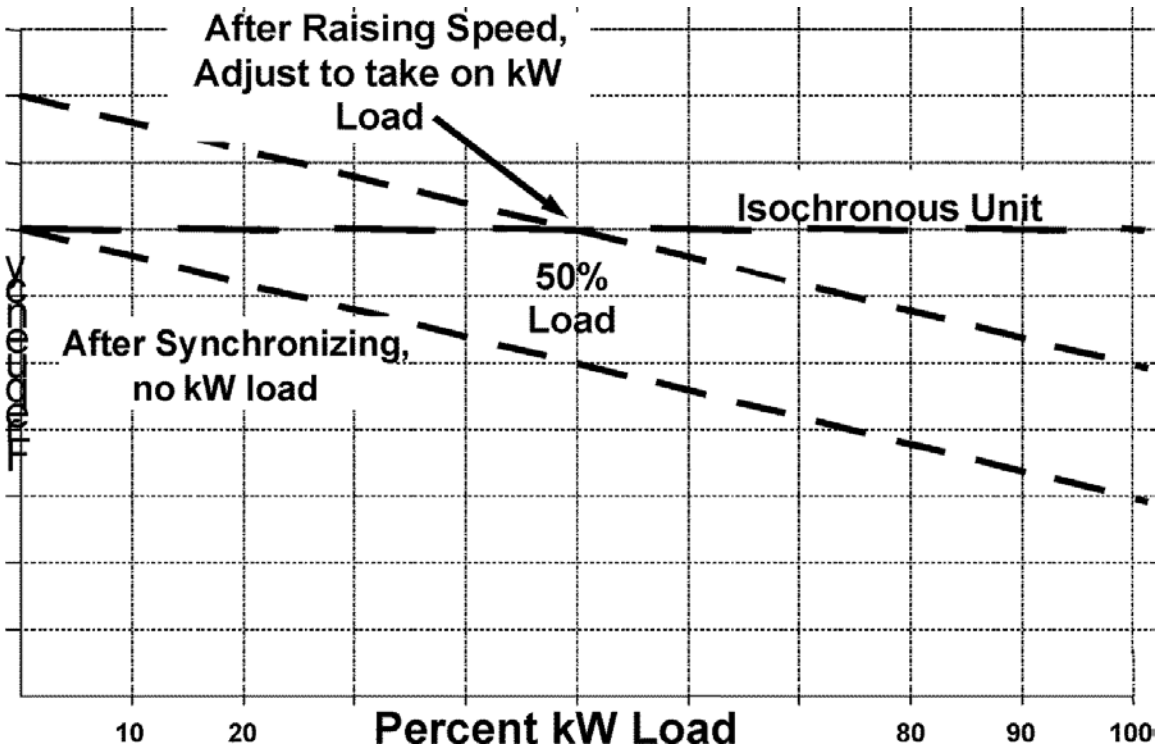

Figure 31: Speed Droop Characteristic

An advantage of speed droop is the simplicity of the load sharing mechanism. The disadvantage is that system speed, hence, generation frequency, varies with load changes. If system speed is to be maintained as load varies, the speed set point of the governor must be adjusted as load changes to correct the system speed. A droop system generally does not provide for tight regulation of system speed and frequency. In many of today's power generation applications, this variation of frequency is not acceptable.

One method of achieving fixed speed operation of paralleled machines with changing load is to parallel two generators to the same bus with one of the two governors set to isochronous mode (zero speed droop) and the other generator set with speed droop, typically at a 2% to 5% level. The generator set for isochronous operation is considered the lead generator. The lead generator is used to keep the bus frequency constant.

The speed set point of the machine operating in droop is adjusted to a level so that at the given system speed, a fixed power output level is achieved. Thus, it is referred to as a base load machine because it is operating at fixed power output. During operation, this machine maintains a constant level of real load output, so long as the lead machine maintains a constant bus frequency. The amount of load it carries when operating in parallel is set by its speed reference.

The lead machine that operates at constant speed has no speed droop. Thus, it must provide power to all load not provided by the base load machine or else

system speed will vary. The lead generator is also known as the swing machine, since it is exposed to all changes in load, varying its power output to match changing load conditions. Care must be taken to ensure the load does not vary outside the operating power range of the swing machine, or system frequency will not be maintained.

Isochronous Load Sharing Operation

In systems where speed and frequency deviation are a primary concern, speed droop control is not a viable load sharing method. Often, this is true when providing power to data centers or computer facilities. In these cases, isochronous operation at constant rated speed is required. Constant rated speed must be maintained regardless of the amount of load on the machines.

Isochronous operation can be obtained by using load sharing electronics which determine the average load of all the machines in the system. When this average system load is determined, it is fed into a kW controller which drives the machine kW output to the same level as the system average. The result is all machines in the system share equally on a percentage of capacity basis. Figure 32 shows a kW controller block diagram.

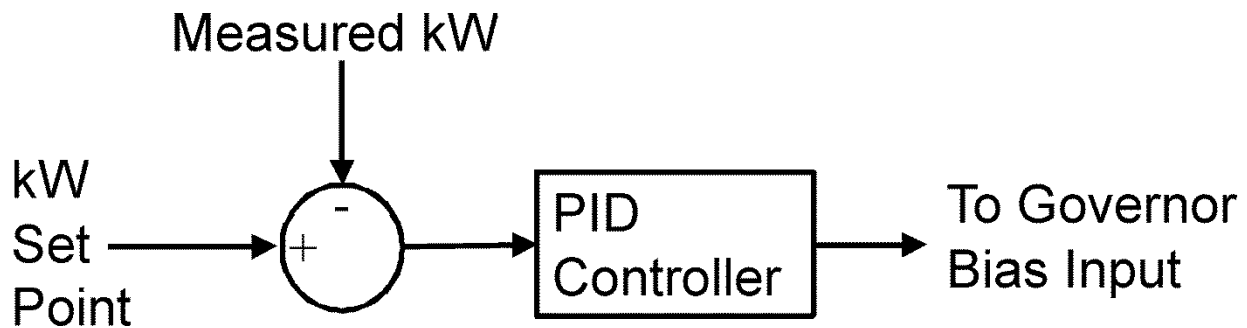

Figure 32: kW Controller Block Diagram

One common method used to determine the average loading of a system of generators is an analog load share line. The voltage on the load share line ranges between some minimum value that indicates the system has no load, and a maximum value that indicates the system (total capacity of all connected generators) is fully loaded. By measuring the load share line voltage, one can determine the average amount of system load. If the voltage is halfway between the minimum and maximum of the load share voltage range, it is indicated that the average system load is 50 percent capacity.

Each load share device drives the load share line with a voltage that is proportional to its percentage of load (Figure 33). Each load share device contains an internal resistor between the voltage driver and the load share line output to limit the current from the voltage driver. The load share outputs from all the devices are connected together; therefore, the voltage on the common connection point are the average of the load share line voltages contributed by each of the load share

control devices. This average voltage is a proportional representation of the average percentage of load of the system.

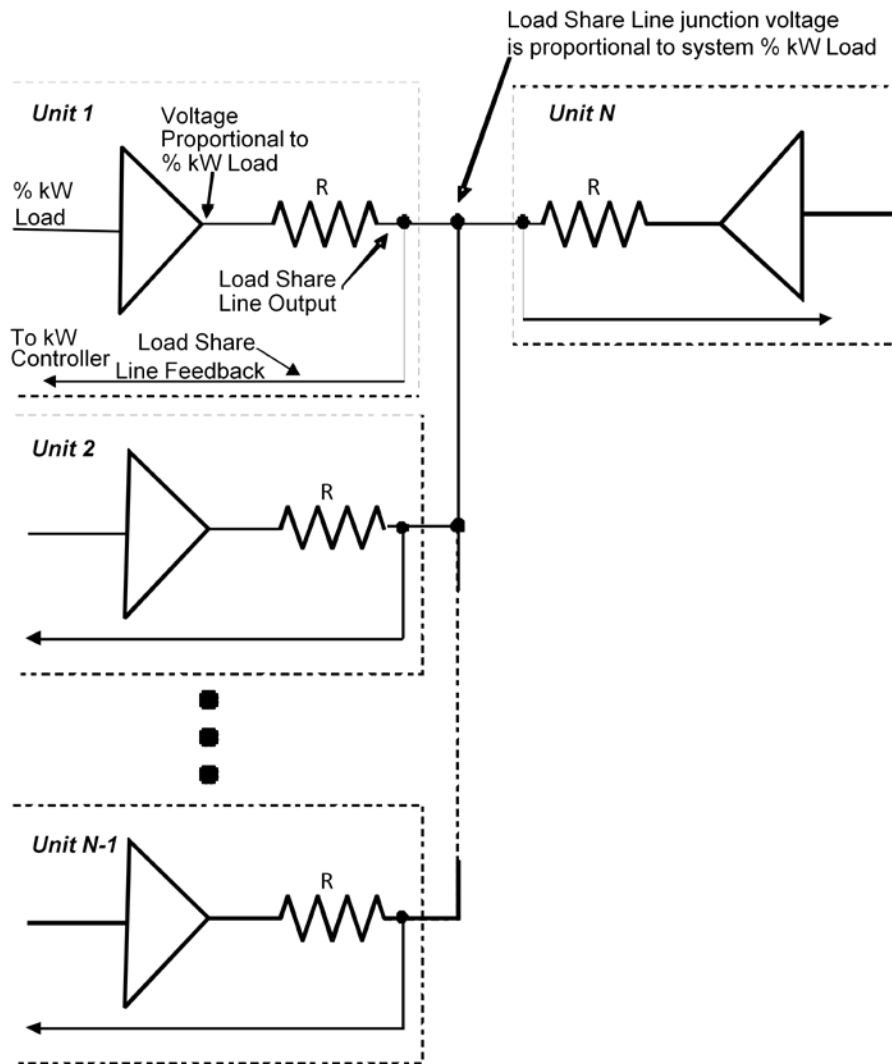

Figure 33: A Load Share Line Implementation on a System of N Machines

The goal of a load sharing system is for all machines to share equally on a percentage of capacity basis. As previously discussed, each machine contains a load controller, or kW controller, which provides regulation of the machine's kW output. The setting for each kW controller is derived from the system load share line voltage. The load share line voltage is measured, scaled, and fed back to the machine's kW controller; so the setting for the kW controller is the average percentage load of the system. Therefore, each machine's kW controller is driving the machine's kW output to a level equal to the average percentage kW load of all of the generators in the system. In a properly tuned system this results in all machines sharing kW equally on a percentage of capacity basis.

Each load share module has a set of internal contacts that physically disconnect it from the load share line circuit when the generator breaker is open and the machine is not connected to the system. These contacts are open when the unit's generator breaker is open to ensure there is no contribution from the offline generator to the load share line.

Most existing load share line implementations use the analog load share line as described previously. However, some more recent systems replace the analog load sharing lines with digital communications between the generators (inter-genset communications.) Figure 34 shows a system where Ethernet communications are included for inter-genset communications. The load sharing implementation is very similar to that of the analog system, except that individual machine loading is reported over communications rather than an analog signal on the load share line. The average system load is determined by summing the kW generation of all the generators in the system, and dividing by the machine capacity currently on line.

When load sharing is accomplished over inter-genset communications, it is only a small step to implement reactive power (kVAr) sharing in a similar manner. In addition, there may be other advantages to inter-genset communications including sequential start controls, demand starting and stopping of generators, and dead bus breaker arbitration.

Load Ramping

Often settings are provided to ramp kW generation when a generator transitions on to or off of the utility or an islanded power system that is load sharing. The load ramp feature helps protect the system from rapid block load transfers to or from the generator that is transitioning, minimizing the occurrence of breaker operations or degradations to system stability as generators are brought on line or off line.

Speed Trim Control

In kW controllers utilizing PID control with some integral gain, it is possible the system speed might drift even though kW sharing is accomplished. Basically, the goal of the kW controller is to accomplish kW load sharing; maintaining system speed is not a primary consideration. In systems where speed control is also critical, a second controller is added to accomplish speed trim to maintain steady state system speed. Figure 35 shows a system employing a kW controller and speed trim controller. Although it may seem the controllers could fight each other, in the end both kW sharing and maintenance of system speed are achieved.

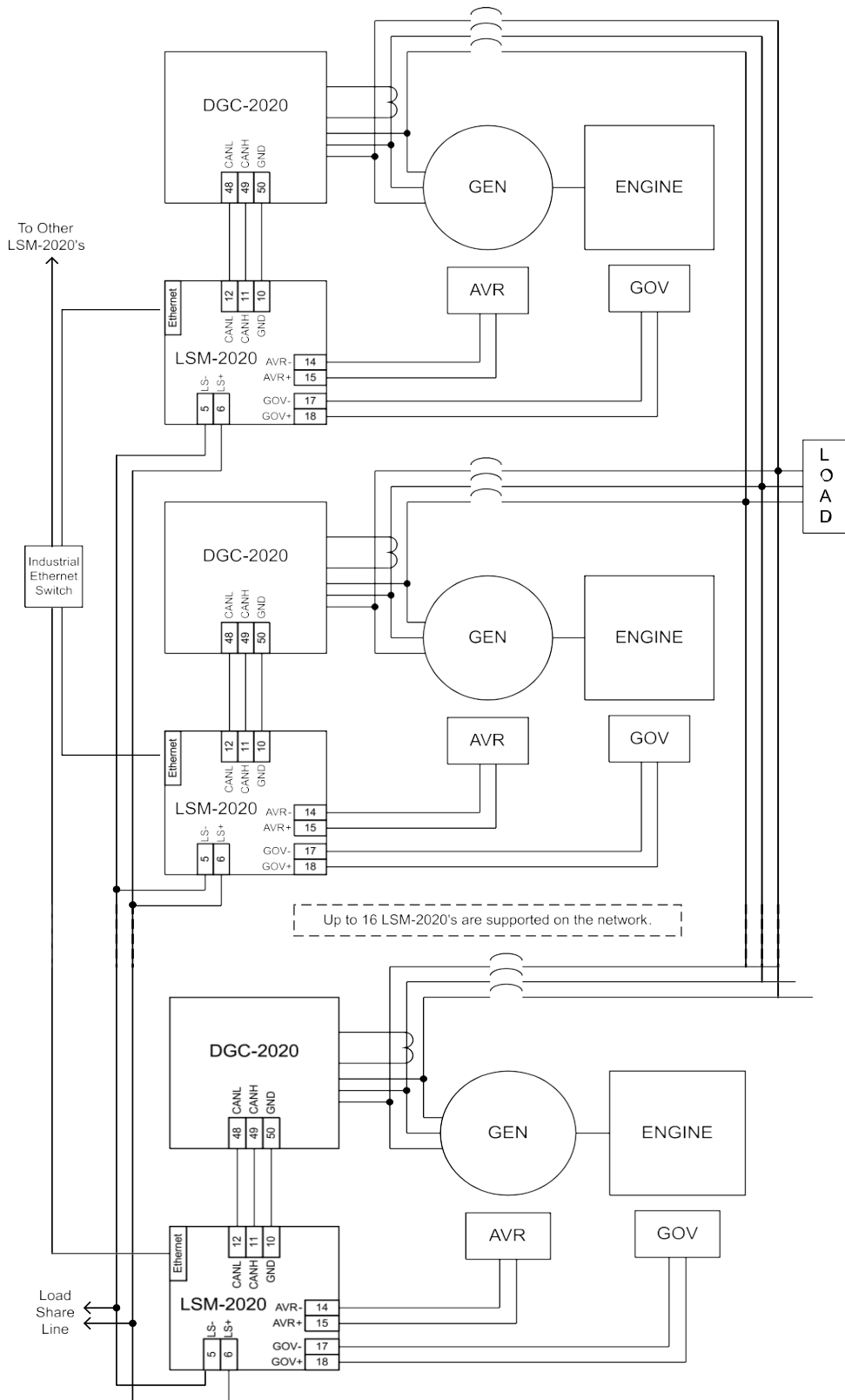

Figure 34: Typical load sharing interconnection

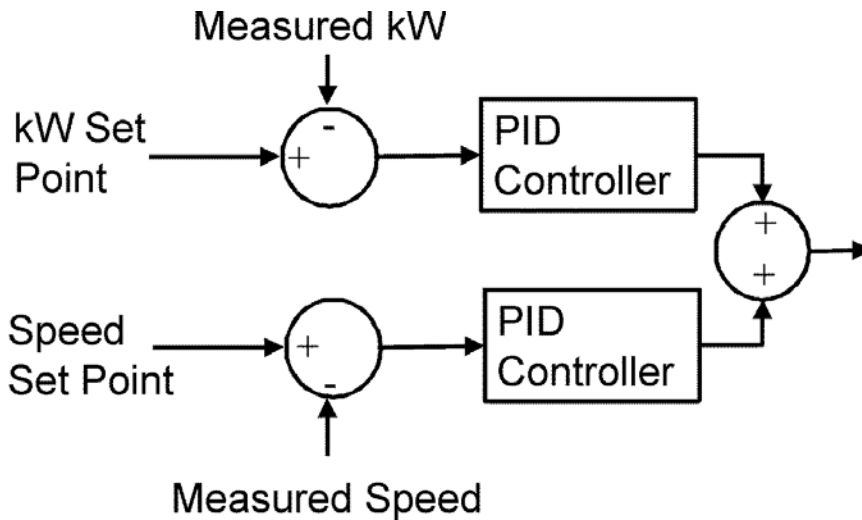

Figure 35: Controller Implementation with kW Controller and Speed Trim Controller

kW Load Control with an Infinite Bus (Utility) Connection

Often, it is desired to operate generators in parallel with the utility; several such situations will be presented in subsequent sections. Figure 36 shows a generator operating in parallel with utility.

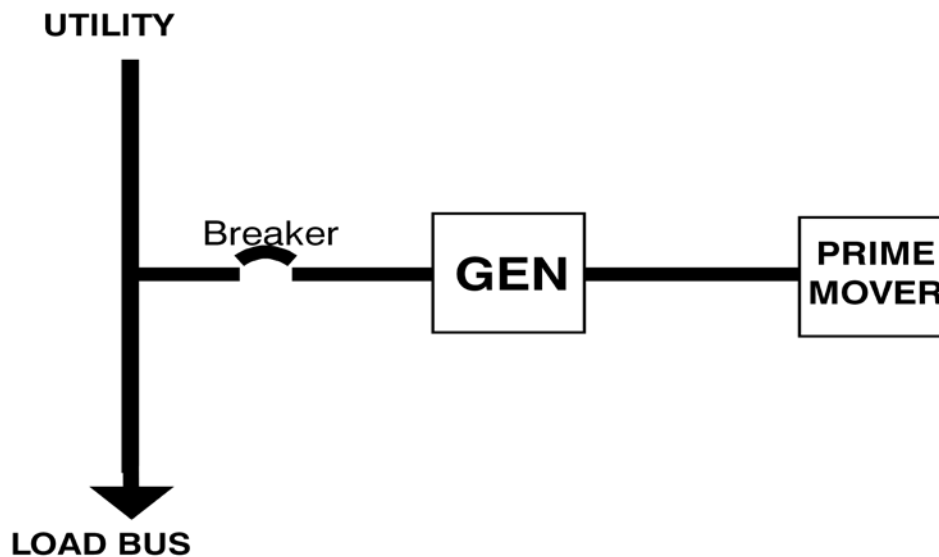

Figure 36: Generator in Parallel with Infinite Utility Bus

The governor plays an important role in utility parallel operation. When a generator set has been synchronized and paralleled to the utility, the speed governor can no longer operate in isochronous speed control mode. This is because the utility connection is considered an "infinite" bus with the characteristic that a single machine cannot influence the bus frequency. Therefore, the speed of the generator is fixed by the frequency of the utility and the governor cannot influence the utility frequency.

If the speed governor remains in the isochronous mode of operation, any difference between its set point and the actual utility frequency results in the speed governor attempting to change machine speed to correct the error. Since the speed cannot be changed, if the governor's set point is higher than the utility frequency, the result would be full kW output and possible generator overload. Similarly, if the governor's set point is lower than that of the utility, the result is a drop to zero kW output and possible reverse powering of the generator. Thus, some mechanism must be employed to regulate the generator's kW output.

One common practice is to place the speed governor in droop mode operation as previously discussed. No special equipment is required except the speed governor must be capable of operating in droop mode and a means must be available to modify the governor set point. When first synchronized to the utility connection, a droop governor with rated frequency equal to the utility frequency will produce zero power. The governor set point must be increased for the generator to increase the machine's kW output. Thus, a droop generator can be base loaded to provide a fixed level of power output, and the utility makes up any differences in real power demanded by the load. With this scheme, operation of the generator in parallel with the utility connection can be very simple (See Fig 37).

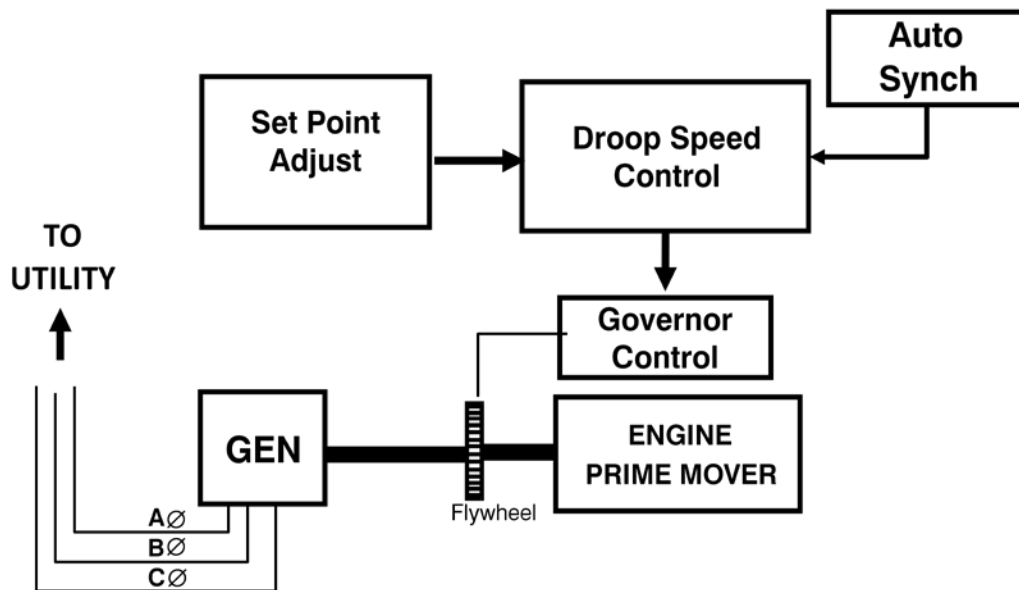

Figure 37: Droop Governor Controls to Base Load to Utility

When it is desired to leave the governor in Isochronous mode, the kW controller discussed in preceding sections can be utilized to control the governor and achieve desired machine kW power output levels. In the case where the unit is connected to the utility, it will derive its kW control setting from the Base Load Level (%) setting and must disregard the load share line input.

In short, when the generator breaker is open, the kW controller is disabled. When the generator breaker is closed but the utility tie or mains breaker is opened,

the kW controller's setting is derived from the load share line. When both the generator breaker and utility breaker are closed, the kW controller set point is derived from the Base Load Level (%) setting. Figure 38 shows a generator with an isochronous governor and kW load controller paralleled to utility.

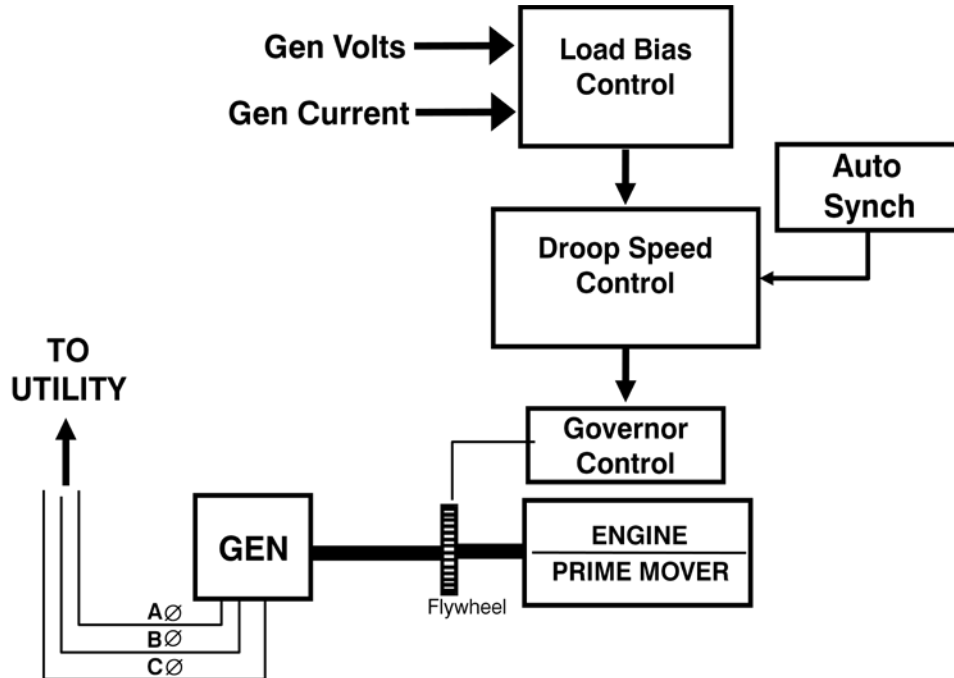

Figure 38: Isochronous Governor Controls to Base Load to Utility

In some applications, it may be desirable to allow the utility to provide up to a fixed amount of power, but above certain levels supply additional power requirements with generators. An example is a situation when power is in high demand, such as during peak demand periods, where it is cheaper to run generators than to pay a utility premium for peak power. Above a certain power level, generators may be placed online to pick up the changes in load; this mode of operation is referred to as peak shaving. In general it is usually cheaper to purchase utility power than to run local generators; however, during peak demand periods or above demand levels where load penalties apply, it may be more cost effective to supply some or all power requirements with local generation. Figure 39 shows a peak shaving characteristic where generators may be operated to pick up kW load from the utility source.

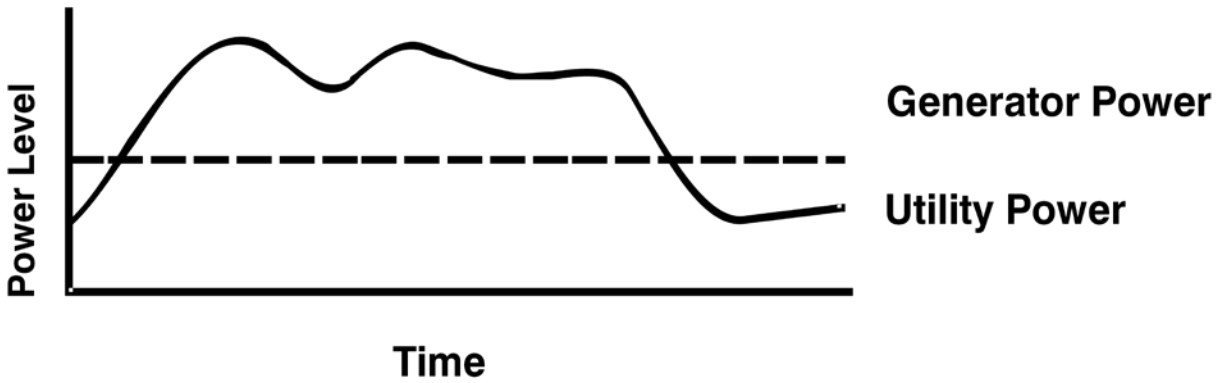

Figure 39: Peak Shaving

Because it is difficult to deal with changing loads in a droop generator system or an isochronous system in base load mode, an element can be added to an isochronous machine to provide real power (kW) control to control the peak power level coming into a facility from the utility. The kW control element enables the use of multiple generators in parallel with the utility connection for base loading or peak shaving purposes, and can implement load sharing among generators on an isolated load bus that is not connected to the utility. The value in this added capability is increased power reliability. It is possible to provide peak shaving when the utility is present and to provide backup power from the same generators when the utility experiences an outage. Figure 40 shows a diagram of a generator with controls for peak shaving.

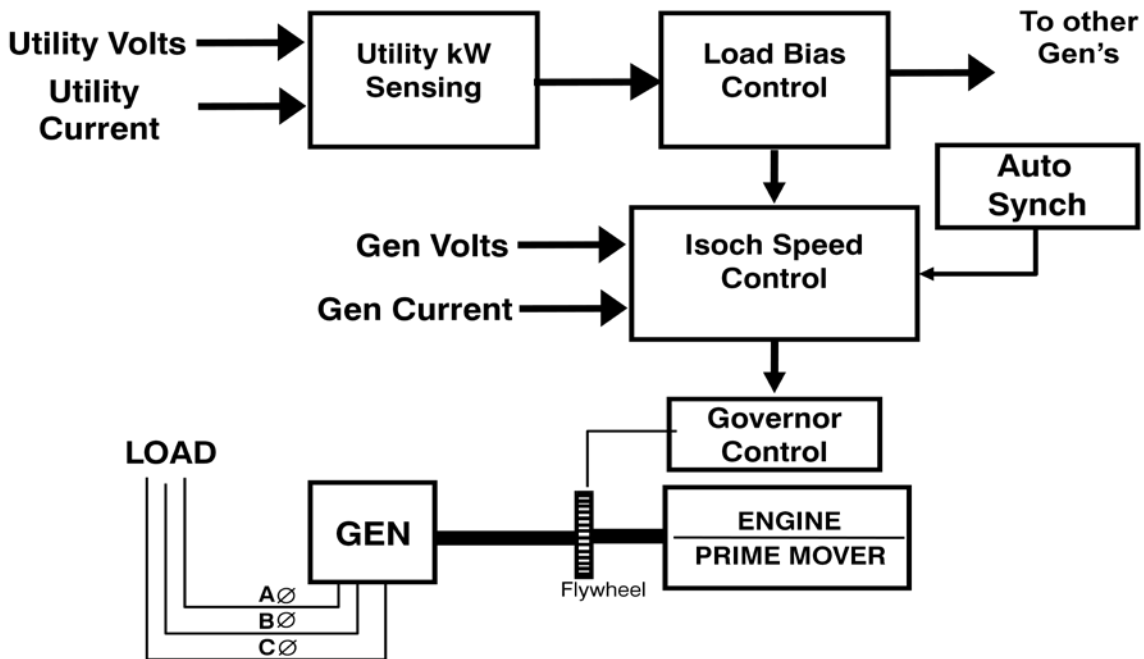

Figure 40: Load control for peak shaving

For example, consider a processing facility where the process requires highly reliable power with a very high cost penalty to the process if power is lost. Suppose the process is such that high load levels, along with a need for reliability and efficiency, have dictated that five generators are required locally to back up utility power and provide local power generation during peak usage periods. The process can be powered by the utility when it is available or by three or more generators during power outages. In addition, peak shaving is required during certain periods of each day, and two generators are required to keep utility supplied power below a demand penalty level. When transitioning from generator power to utility power, there must be no interruption of power to the process. Therefore, closed transitions where the generator operates in parallel with the utility during transition are required to restore the load to utility power. This application yields the following operating conditions:

- Utility power is supplemented by one or two on-site generators when the utility is present to maintain utility supplied power below the demand penalty level.
- Three or more generators must supply power to critical loads during a utility outage.
- Load transitions from generator power to utility power after an outage employ closed transitions to prevent power interruptions to the critical loads.

When it is necessary to synchronize a bus with multiple connected generators to the utility connection, a utility automatic synchronizer performs the same function it does when synchronizing only two generators: The frequency, phase angle and voltage of the two sources are matched. However, instead of controlling the frequency of only one machine, the synchronizer must be capable of controlling and adjusting the frequency and voltage of multiple paralleled machines as well as a single generator, based on system operating conditions. When synchronizing multiple paralleled generators to another source, the auto synchronizer can adjust the frequency of the connected generator bus by biasing the signal on the load sharing line connected to each machine's governor on the system (Fig 41). Biasing the load sharing line accomplishes simultaneous adjustment of the frequency of all generators while continuing to provide precise load sharing among the generators. When the tie breaker between the generator bus and the utility has been closed, the automatic synchronizer is disabled.

When the generator bus is paralleled with the utility, the load bias controller must fill a different role. After the automatic synchronizer has completed its task and closed the tie breaker, the load bias controller receives a contact closure from the tie breaker, placing it into load control operation. In a system where the utility has provided power to the load and it is desired to transfer the load to the generators, generally the load bias controller gradually adjusts the load sharing lines to avoid "bumping" the system by picking up the load too quickly and to ensure that the generators do not absorb kW from the utility and reverse power the generators. In this operation, the load bias controller begins to ramp up the load level at a programmed rate (Fig 42). This operation transitions the load or a portion of the load from the utility to the generator bus. A predetermined power level may be set to keep the utility power supplied to the load

below a penalty level in a peak shaving application. It also could be set to a fixed export power level if used in a base loading application

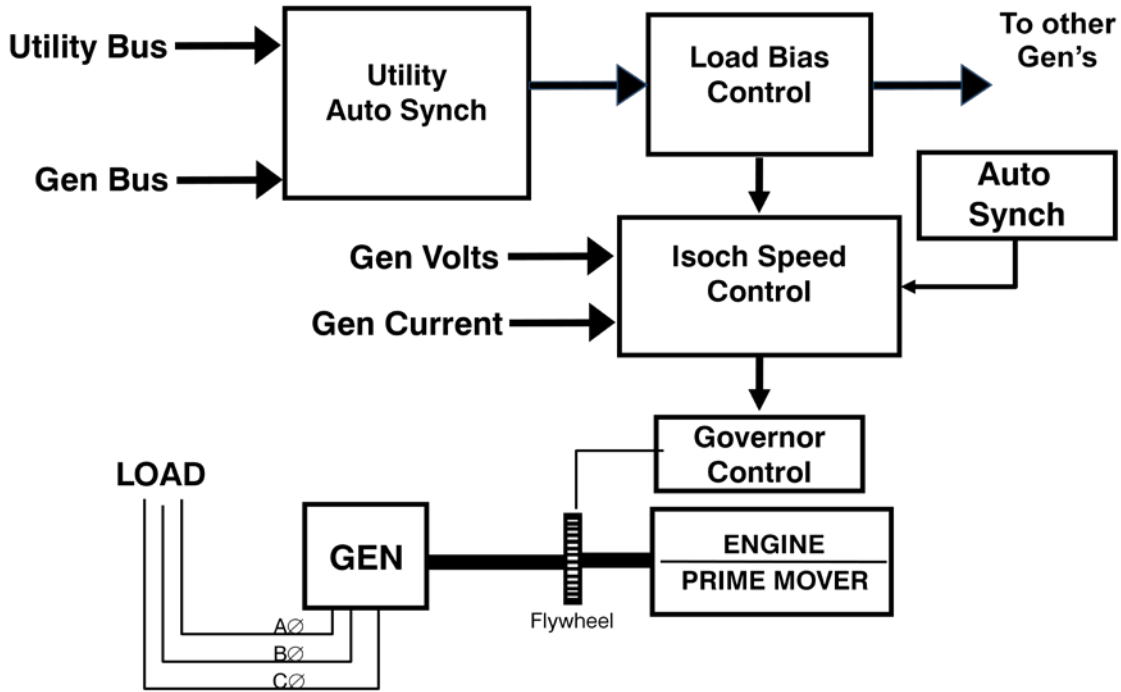

Figure 41: Synchronize to Utility with Multiple Generators

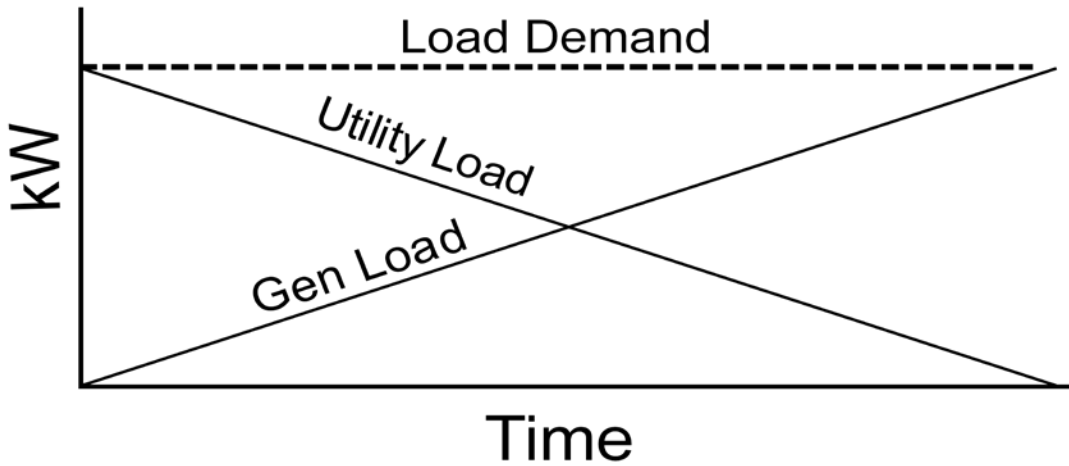

Figure 42: Load transition to generator bus

In a situation where the generators have provided power to the load in an islanded mode and it is desired to transition the load back to utility power, the automatic synchronizer performs the same function as previously discussed and closes the tie breaker. When the load bias controller receives the contact closure, indicating synchronism to the utility, the load bias controller gradually begins to ramp down the load sharing lines. This allows the generator's load levels to decrease and the load to be transferred to the utility without "bumping" the system. When the load has been transferred to the utility from the generator bus, the generator can be taken off line, which leaves the load on utility power.

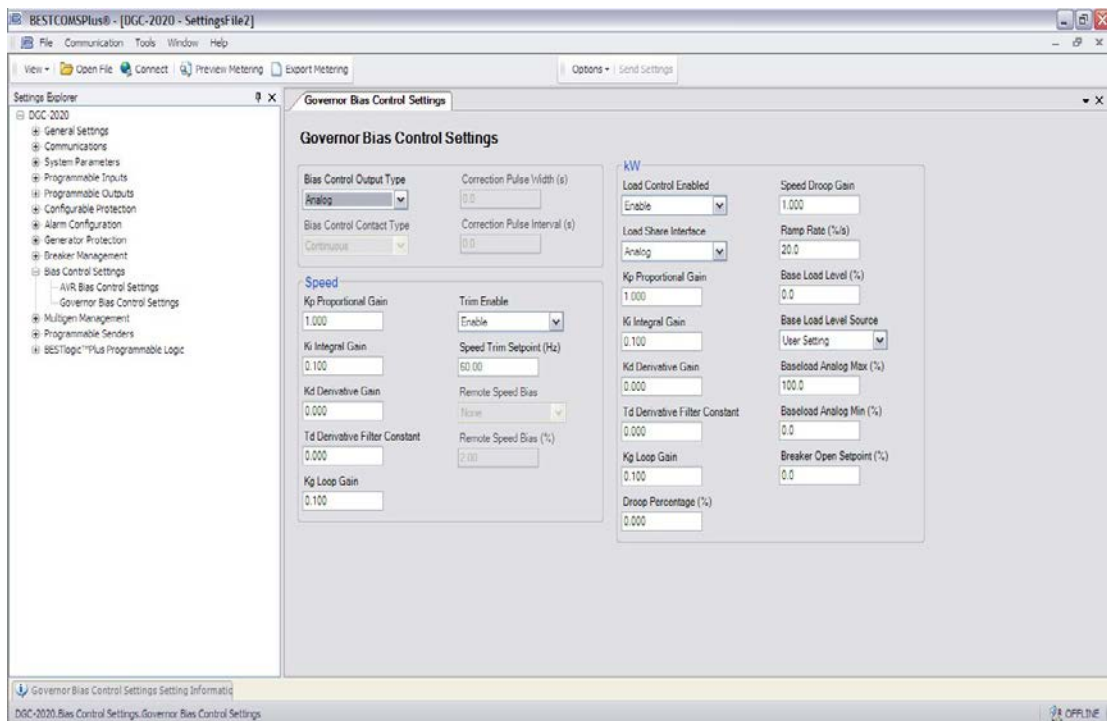

Figure 43: Load Ramping On/Off - Ramp Rate % Settings (BESTCOMS™)

When using a genset as emergency backup or distributed generation, it is imperative that generator capabilities are recognized and sufficient protection and control elements are implemented to protect both the genset and the load. For instance, Figure 44 shows the nameplate and rating for a generator in a backup application. In this case, in the event of a power outage, the generator could pick up loads of up to its full capacity of 280kW.

Generator Rating				
	kWatts	kVAr	kVA	Power Factor
Generator	280	210	350	0.8

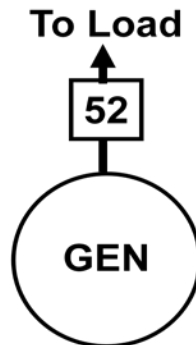

Figure 44: Generator Ratings

In Figure 45, a load is connected to utility power and the genset is off line. All of the power demanded by the load is being supplied by the utility. If the load demand changes, the utility changes to accommodate the change in demand.

	kW	kVAr	kVA	PF
Utility	400	300	500	0.80
Local Gen	0	0	0	0.80
Load	400	300	500	

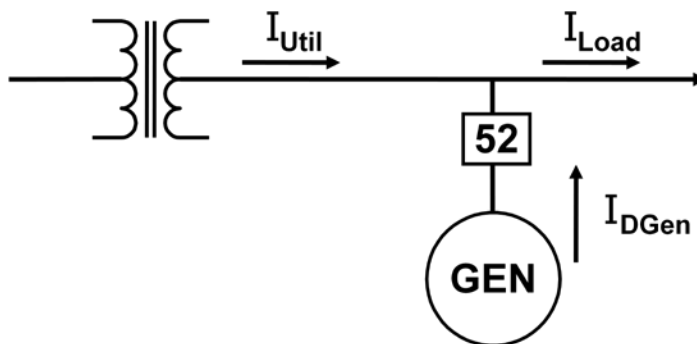

Figure 45: Utility Power to the Load

Figure 46 shows the impact of loss of utility power and the attempt to support the load with the genset. It is clear that there will be significant genset overload since 400kW are demanded of a machine with a capacity of 280 kW. The result will be that frequency and voltage drops and the genset fails to supply the load demand.

	kW	kVAr	kVA	PF
Utility	0	0	0	
Local Gen	400	300	500	0.80
Load	400	300	500	0.80

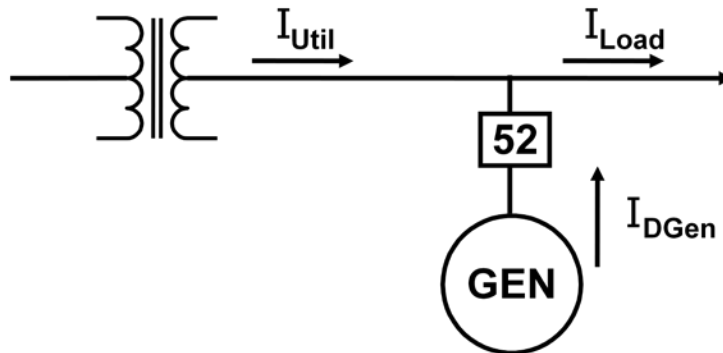

Figure 46: Generator Power to the Load

In order for this application to function properly, load must be reduced to within the rated generator capacity; such decrease of these loads is often referred to as load shedding. Load shedding may be performed by monitoring kW levels (Fig 47) and/or frequency (Fig 48). When these set points are exceeded, noncritical load breakers can be tripped to reduce the total amount of load and allow the generator set to pick up the remaining critical loads.

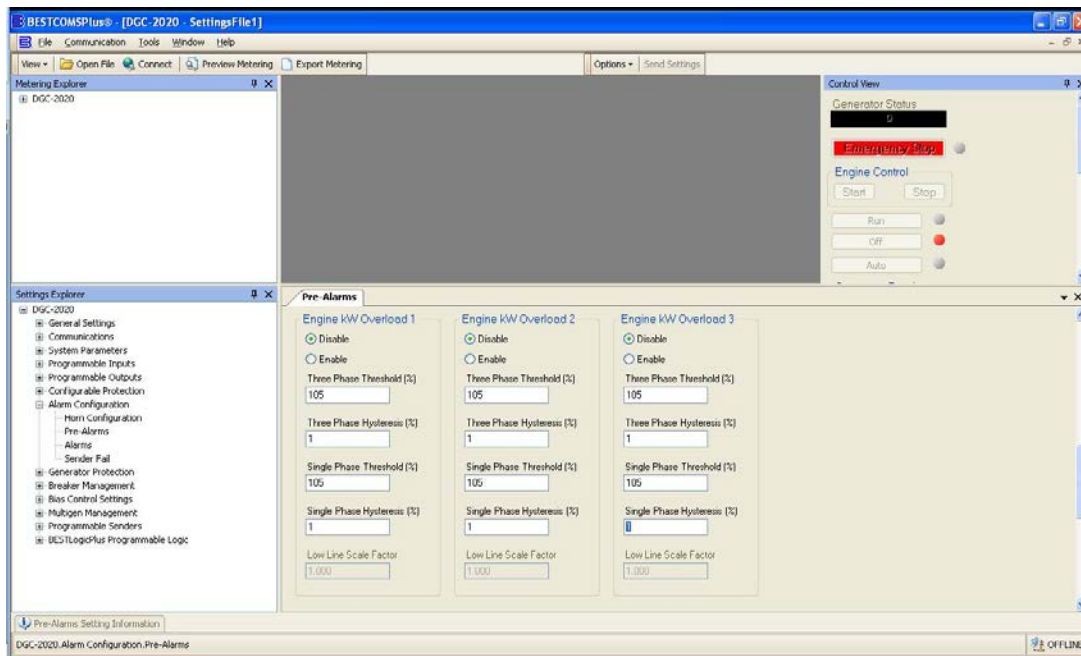

Figure 47: kW Overload Settings (BESTCOMSPPlus®)

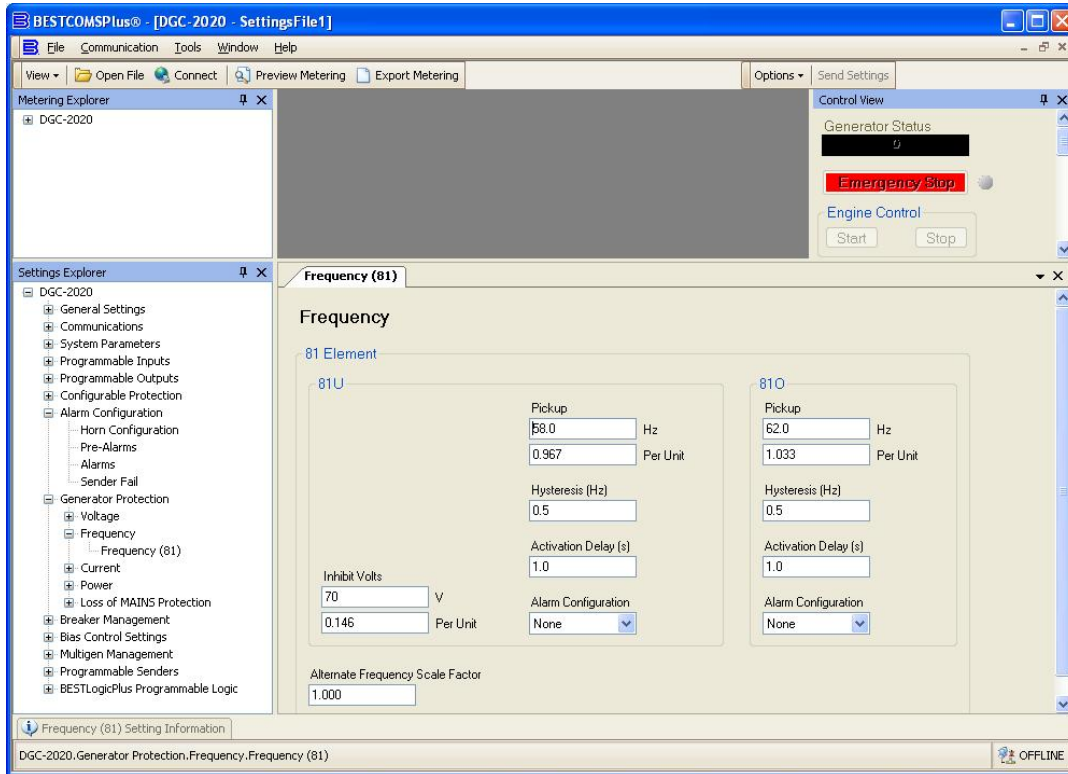

Figure 48: Underfrequency Protection Settings BESTCOMSPPlus®)

In the same application, the genset can be used to peak shave or base load with the utility. By paralleling the genset with the utility, it is possible to adjust the load sharing between the two sources to support the load demand. The load can be shared equally, proportionately to rated load capacity, or any division required within the capacity of the sources (Fig 49). Often the genset is operated near its ratings, because operation near rated load is normally where lowest cost per kW is achieved.

	kW	kVAr	kVA	PF
Utility	200	300	363	0.55
Local Gen	200	0	200	1.00
Load	400	300	500	0.80

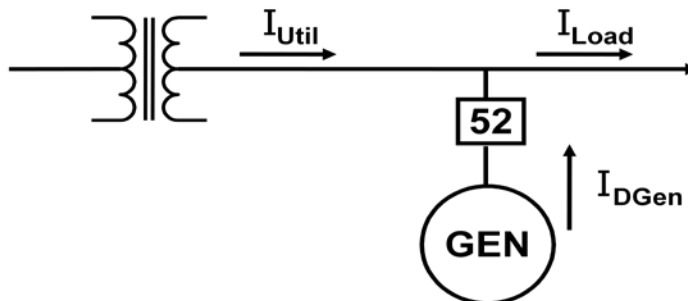

Figure 49: Generator kW shared with utility

In some facilities, poor power factor can increase the cost of utility power because of power factor demand penalties. In these situations, it may be desired to operate the genset as a reactive power source. These systems operate in an overexcited mode to supply kVAr to improve the overall power factor at the utility tie and reduce kVAr demand on the utility. The generator kW may be reduced to save fuel and the majority of the load kW can be supplied by the utility source. In the example of Figure 50, the utility supplies 75% of the load kW and the genset supplies 25%. This ratio can be adjusted by varying the amount of kW supplied by the genset relative to that supplied by the utility. Beyond supplying losses to keep the generator rotor spinning, kW to the load accounts for most of the fuel burned by an engine.

	kW	kVAr	kVA	PF
Utility	300	90	313	0.96
Local Gen	100	210	233	0.43
Load	400	300	500	0.80

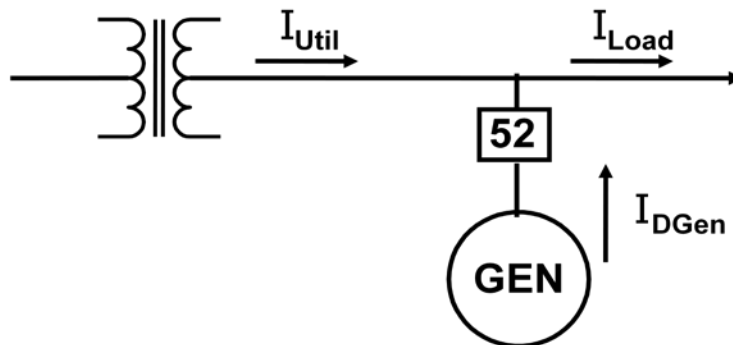

Figure 50: Genset operating to supply kVAr

Note that the load demand is being met by the sum of the power from the two sources. If the fuel for the genset is reduced to allow the utility supplied kW to increase, one must be careful not to overdo it. If the fuel is reduced too far, what happens to the generator operating in parallel with the utility? If taken too far, generated kW may be reduced to such a point the generator starts absorbing kW from the utility; the utility will reverse the power flow of the genset and the generator will operate as a motor, supplying torque to the prime mover. This condition, commonly known as motoring or reverse power, is very detrimental to the genset; protection should be employed to sense this condition. This can be implemented as part of the genset controller or by a reverse power relay. Figure 51 shows typical settings for reverse power protection.

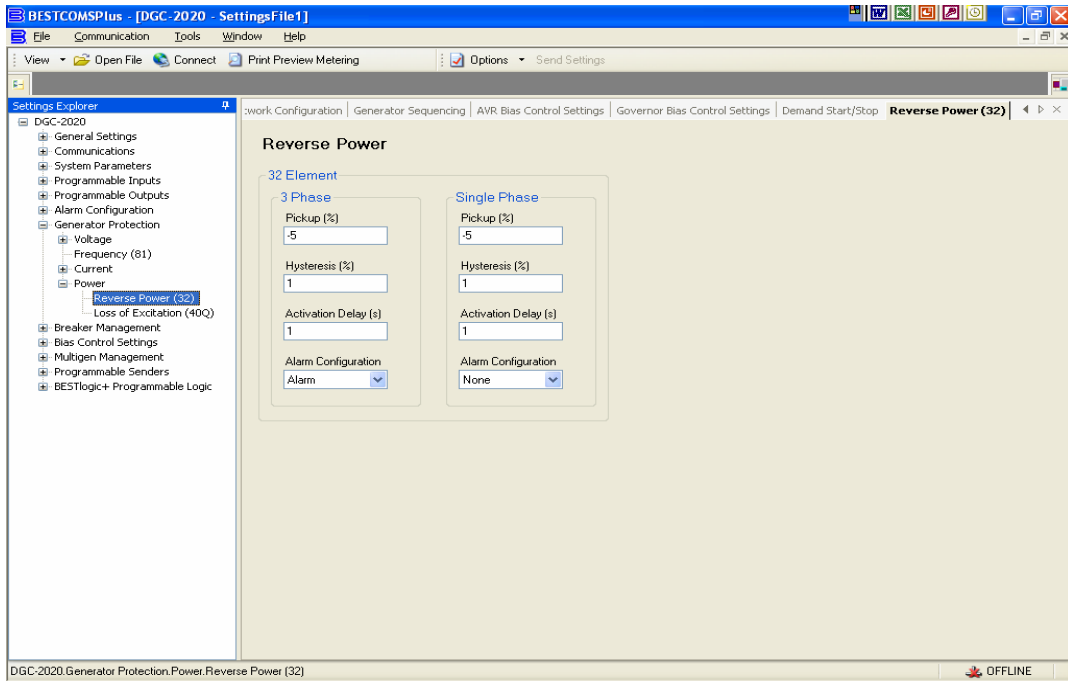

Figure 51: Reverse power protection (BESTCOMSPPlus®)

Load Management and Generator Sequencing

When driving large loads or accomplishing peak shaving with multiple paralleled generators sets, it is necessary to have an orderly addition and removal of the gensets from the bus based upon the load demands. Thresholds can be set in the controller to start and stop machines based upon loading of the system. It also is advisable to set proper limits and hysteresis to prevent machines from continually being started and stopped as the threshold is reached for adding or removing machines from the system (Fig 52). Often, provision for this type of control is included within the functionality of the genset controller.

The operator may choose from a variety of criteria to select the order in which machines are added and removed. They may elect to have the generator sets come on line by size, adding the largest or smallest unit first. They may choose to have them added and removed based on the service hours of the genset, in order to balance the run hours on each machine. They may simply choose to add and remove the machines based on a priority number assigned to each machine (Fig 53).

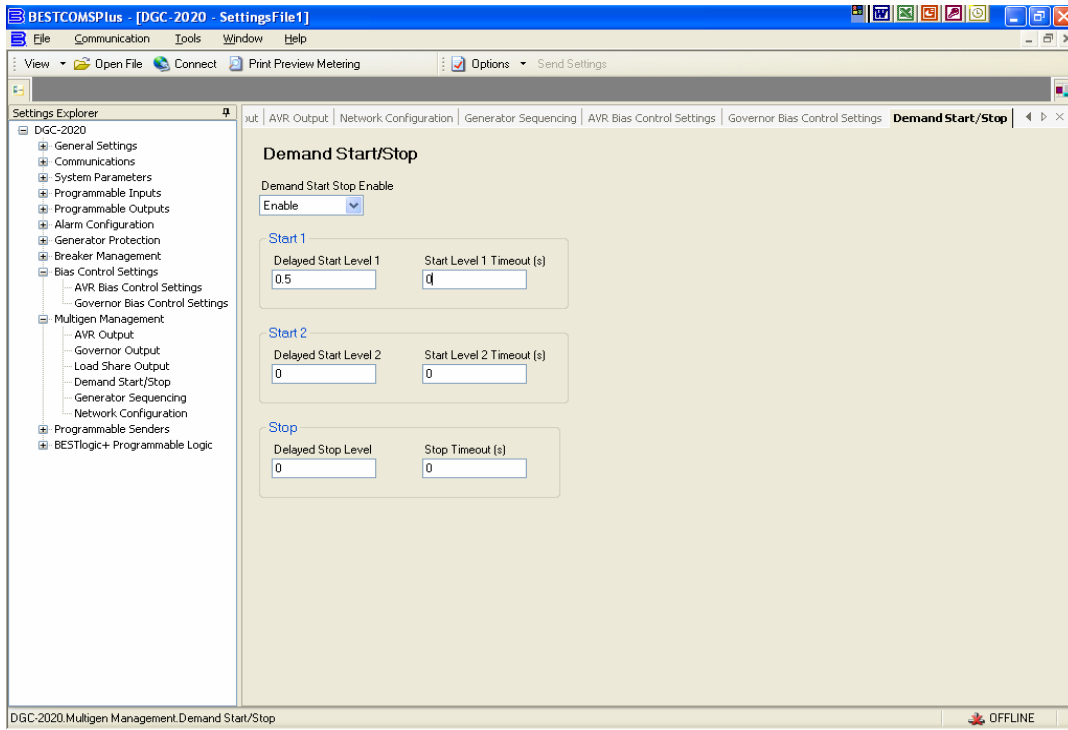

Figure 52: Demand Start/Stop (BESTCOMSPiUs®)

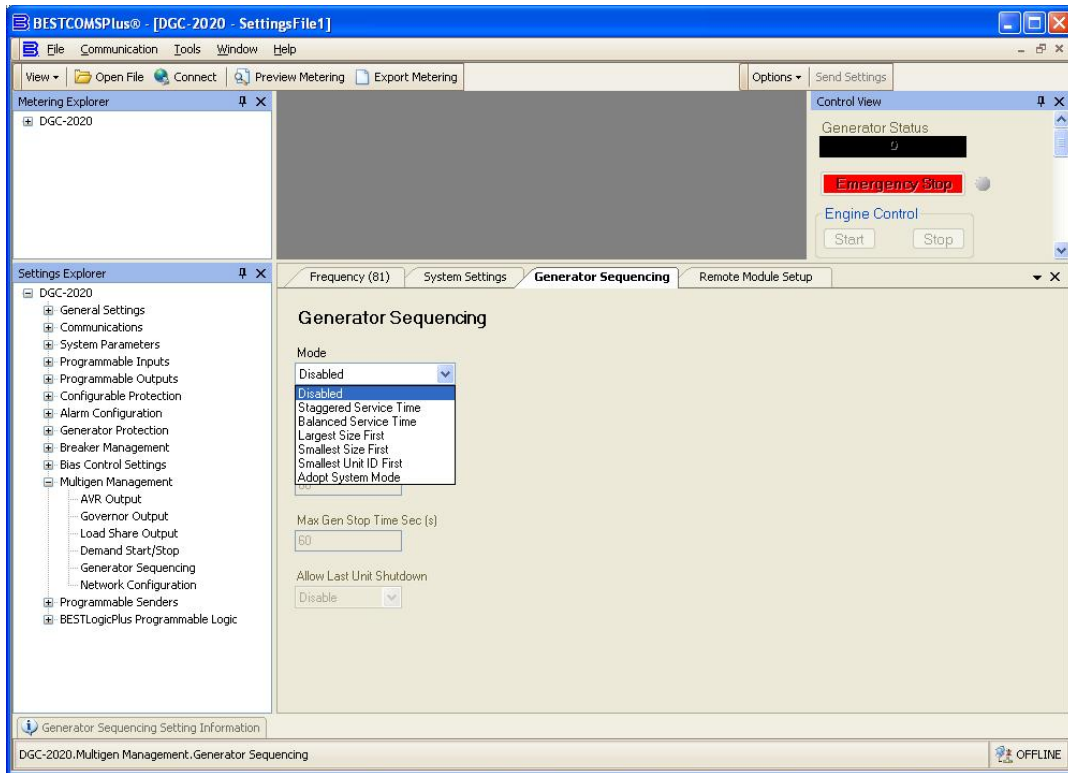

Figure 53: Generator Sequencing Settings, Mode Selection (BESTCOMSPiUs®)

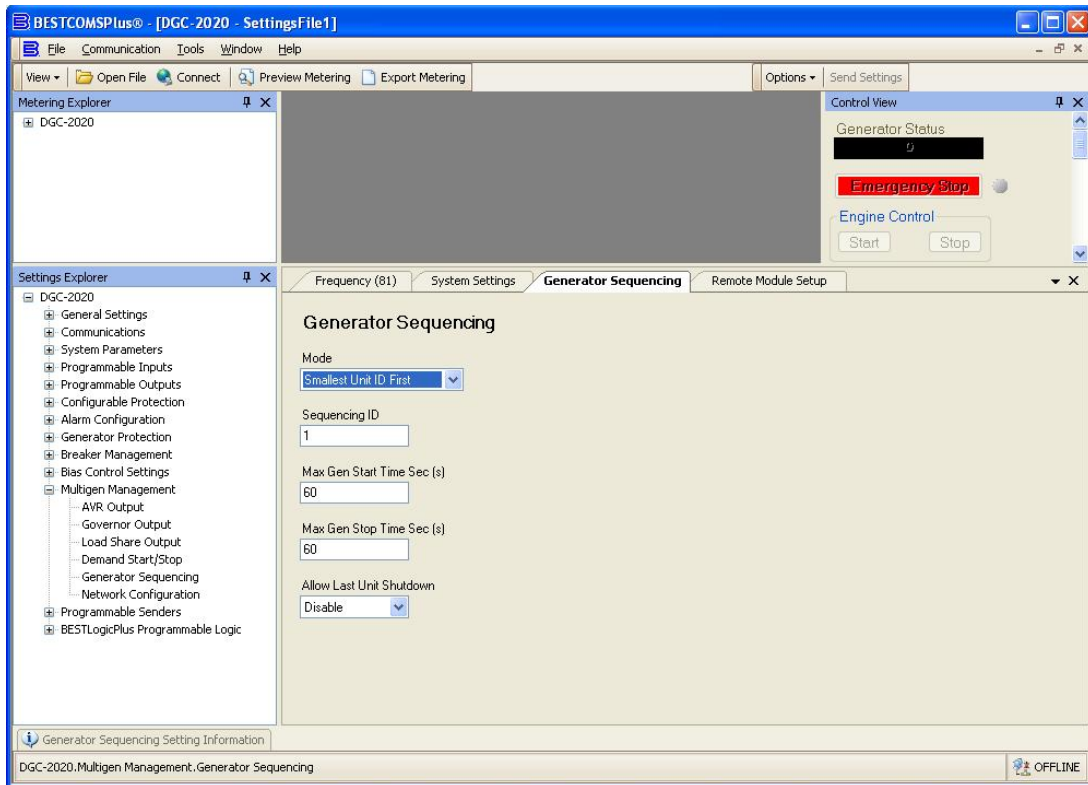

Figure 54: Generator Sequencing Settings Screen (BESTCOMSPlus®)

kVAR Control Overview and Theory of Operation

When the generator has been synchronized with other generators or to the utility, some means must be provided to achieve reactive power (kVAR) sharing among the generators. The most common ways to control kVAR sharing are either a) to implement voltage droop or cross current compensation or b) over intergenset communications. Voltage droop is very similar in operation to the speed droop discussed previously in this paper. However, rather than the speed reducing proportionally to the real power load, the voltage is reduced in proportion to the amount of the reactive power load placed on the machine. Cross current compensation is similar to isochronous operation of the governor controller. However, rather than using load sharing lines, the kVAR load of each machine is determined by interconnecting current transformers between machines. In the cross current loop, the net sum of all of the currents equals zero current flow when the VAR load of all machines is equal, resulting in zero voltage droop of the machine. Communications-based kVAR sharing involves calculating the average kVAR loading of the system, and the kVAR controller in each machine drives the kVAR output of the machine to that average value based on the machines capacity.

When a generator is paralleled to the utility, a kVAR controller or power factor controller may be used. Because the utility maintains the system voltage, it is possible to use a kVAR or power factor controller to maintain the desired kVAR output on the generator or generator system.

Many modern genset controllers offer analog outputs to control the voltage regulator's set point in order to control the kVAR or Power Factor level of the generator when it is connected to the utility. These controllers, such as the DGC-2020/LSM-2020, provide an output of 4-20mA or ± 10 Vdc to interface with the summing junction of the automatic voltage regulator to bias the setpoint and regulate the desired kVAR or power factor level.

When VAR control mode is selected and the generator is paralleled to the utility, the kVAR controller's set point is equal to the kVAR set point percent setting. The setting is in units of percentage of the machine's rated kVAR, which is calculated from the rated kW and rated Power Factor.

When Power Factor control mode is selected and the generator is paralleled to the utility, the VAR controller's set point is calculated as the percentage of rated kVAR that maintains the power factor of the machine at the Power Factor set point setting.

Summary

This paper has examined the fundamentals of the reciprocating engine, how to control it, and options for protecting it. We have examined NFPA 110 and how it mandates some of the features required by the genset controller and protection when used in applications where human lives are threatened if power is lost. The paper has discussed the advances of engine technology and how EPA mandates impact genset control technology. This review is intended to give the reader a better understanding of the merging of older implementations with modern state of the art technology to create a complete package that provides superior control, protection, and communications for the entire genset.

It has been shown that the addition of auto synchronization and kW and kVAR control capabilities to bias the machine's governor and voltage regulator to achieve desired voltage, frequency, phase angle, kW and kVAR output make it possible to operate generators in parallel in island systems or in utility parallel configurations. Through a simple case study, some of the benefits of paralleled generator operation were explored, along with some of the protection requirements.

From the simple standby generator to the large generating station, control of the real power load when the genset is connected to a network is feasible with some addition of controls to the generator. Full operation automation is feasible by considering modes of operation and assembling the proper functions to duplicate normal operator activity. Remote monitoring of the plant, even complete remote control from a remote site, can be accomplished through the use of microprocessor based genset controller hardware for machine control and protection.

GLOSSARY OF TERMS

First, we must define many of the simple concepts and devices that are used on the engine of a generator set. The following is a list of devices that are commonly employed:

Coolant Temperature Senders

The engine's temperature is converted to resistance by the Coolant Temperature sender. This device is installed in one of the channels of the engine that has liquid coolant circulating through it to remove the heat created by the combustion chamber. This sender is a temperature sensitive device with either a positive or negative temperature coefficient that allows a meter or controller to calculate the engine's temperature.

Oil Pressure Senders

The oil pressure sender converts the mechanical pressure created by the oil pump into a resistance quantity usable by the controller to protect the engine from loss of lubricating oil pressure and damage due to increased friction from the loss of lubricating oil on the bearings and other engine parts.

Magnetic Pickup (MPU)

The magnetic pickup is a variable reluctance sensor, most commonly used as a speed sensor. In an engine control application, the mpu senses the flywheel teeth and converts the speed of the engine into an AC signal with a frequency that is proportional to the engine's speed.

Engine Hours (Engine Run Time)

The engine's operating time (when the engine is running) is monitored and displayed as Engine Run Time or Engine Hours. This information is used to calculate the maintenance schedule for the engine and can also be used to help predict the overhaul or replacement schedule for the engine.

RPM

The Revolutions per Minute, or RPM, of the engine is the engine's rotational speed. With a genset, the rated speed required from the engine is based on the number of field poles in the generator and the desired frequency output of the generator.

Air Box

Some engines are equipped with an air box or air damper that closes to prevent combustion air from entering the engine, which chokes the engine to shut it down and prevent it from running. The air box or air damper is closed when an engine alarm is detected, providing a positive means to shut down the engine. Only certain types of engines have this device installed.

Starter (Cranking) Batteries

Typically lead-acid cell or nickel cadmium batteries are used to provide the power to

start the engine via the engine starting motor. These batteries may also be used to provide control power to the engine controls.

Battery Charger

The battery charger keeps the starting or cranking batteries charged to a level sufficient to ensure that the engine can be rotated at a speed fast enough to support successful engine starts.

Emergency Standby Operation

A generator set whose main purpose is to supply building loads during a utility power outage is said to be an Emergency Standby genset.

Prime Power Application

This describes a generator that is the main source of power for the loads. This may also refer to utility power.

ECU

An Engine Control Unit is a microprocessor-based control that is usually engine mounted and monitors all aspects of the engine in order to achieve peak operating efficiencies and minimum exhaust emissions.

SAE

The Society of Automotive Engineers is a group of engineers that sets standards and guidelines for products associated with the automotive industry.

J1939

J1939 is the identification number of a standard published by the SAE for vehicle communications on the CAN bus. The standard defines the protocol for the communications and message structure for communications between devices of the vehicle.

CAN bus

CAN bus is an acronym for Control Area Network bus.

NFPA

National Fire Protection Association is an administrative body that works to develop a consensus standard for equipment.

Generator Set (GENSET)

A typical generator set (genset) is an engine-driven generator used to provide electricity. These sets range in size from a few hundred watts to several megawatts.



Highland, Illinois USA
Tel: +1 618.654.2341
Fax: +1 618.654.2351
email: info@basler.com

Suzhou, P.R. China
Tel: +86 512.8227.2888
Fax: +86 512.8227.2887
email: chinainfo@basler.com