

ALTERNATE SOLUTIONS TO REPLACING AGED STATIC EXCITER SYSTEMS

Richard C. Schaefer, Basler Electric Company
Thomas W. Eberly, Consultant

Abstract: *Over the years, many rotating exciters have been replaced for static exciters on synchronous machines. As these replacement static exciters age, much of the analog hardware becomes obsolete and can no longer be supported by the manufacturer, again forcing the replacement of the entire excitation system. For many systems, the power rectifier bridge has proven to be reliable with replacement components for power SCRs and power diodes utilized in the bridge still being accessible. Today, rather than replacing the entire excitation system, another approach is to replace only the analog portion and keep the power rectifier bridge; hence, saving on the overall cost of a replacement rather than the investment of the entire excitation system.*

This paper will discuss the results of this alternative solution and will demonstrate the improved performance gained by implementing a digital front-end controller into the existing power rectifier bridge/s that can result in substantial cost saving to a project.

INTRODUCTION

In the field today, there are many static exciters that are coming into their 15 to 20 year life cycle of replacement due to obsolescence of the analog control boards. Now multiple solutions are available for retrofitting older static exciter technology.

Approaches may include:

1. Replacing the complete static exciter system, including the power potential transformer.

2. Keeping the power potential transformer and replacing the voltage regulator control and power rectifier bridge(s).
3. Retrofitting only the analog controls and keeping the power rectifier bridge(s), breaker, contactors and power potential transformer (PPT).

The reuse of the rectifier bridges has become increasingly popular as rectifier bridge technology utilized years ago has exhibited high reliability and proven to remain in excellent operating condition. Hence, replacing only the analog controls due to obsolescence and keeping the power SCR rectifier bridge/s may be a favorable economic solution for an excitation system upgrade.

In addition, there are other factors that can prompt the need to re-evaluate the existing excitation system controls' ability to comply with new rules and guidelines in the power industry. With the passage of the 2005 Energy Act, an emphasis on generator excitation model validation, performance testing, and limiter coordination with protective relaying has become mandatory. These issues, along with the increasing need to add a power system stabilizer to the excitation system have emphasized the need to modernize existing equipment and minimize the time required for testing.

With new digital excitation systems, integrated features reduce the package space requirements of an overhaul, while Windows "friendly" operating software with built-in testing tools have made commissioning and data gathering easier.

This paper addresses a retrofit solution where a GE Bus Fed static exciter, manufactured in the 1980s, was upgraded

with a new digital controller, including a new digital firing circuit and gate amplifier board to interface with the existing half-wave 3 SCR and 3 Power Diode Rectifier Bridge, AC breaker/field flash contactor, and power potential transformer.

THE PROBLEM

In Corona, California, a GE Frame V, 64 MVA, 13.8 kV, 3600 RPM cogeneration plant required an upgrade in two of its control systems that would improve the performance and efficiency of the power/electrical blocks. The excitation system and the turbine control system were chosen as the major elements involved in this upgrade. The power plant's turbine controls were modernized with a new digital controller communication system. The excitation system was replaced due to the problems of obsolete printed boards, reactive power control problems, and general lack of equipment support. Both systems use Modbus communication, which is beneficial in streamlining the plant's operation. The existing static exciter was located in a compact, restricted area that contained two parallel convection-cooled rectifier bridges with load sharing reactors on each bridge, an ac field breaker, a field flash contactor, and field flashing scheme. A 1970s rack-mounted analog voltage regulator assembly was mounted on the front door, along with a power supply, a var/Power Factor controller, and other miscellaneous hardware filling in the cabinet's interior. (See Figure 1.)

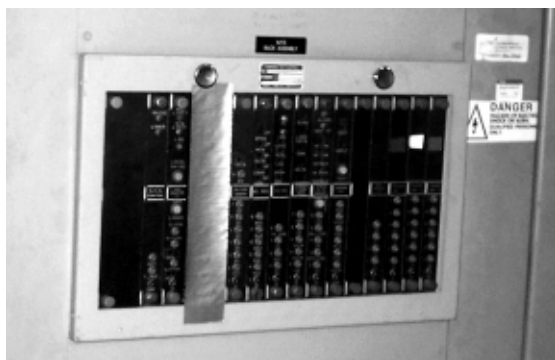

Figure 1: GE Bus Fed Analog Voltage Regulator

RETROFIT WITH A DECS-400 DIGITAL EXCITATION CONTROL

The original equipment represented a 1970s technology design that incorporated many transformers and huge heat dissipating power supplies to provide dc to the Bus Fed card rack. The demolition eliminated all of the analog controls except the two SCR bridges, ac field molded case breaker, dc field flash contactor, the field flash resistor, and dc control interface.

The new equipment included a Digital Controller, DECS-400, mounted on the front door to replace the old AVR rack, a new programmable IFM150 digital firing module programmed for 3 SCR application, and a gate amplifier board that ensured sufficient energy pulses to fire the SCRs on the two existing convection-cooled rectifier bridges. The balance reactors used for the SCR bridges remained as they were installed.

Digital technology offers substantially improved performance and feature integration over its analog predecessor. A voltage regulation of $\frac{1}{4}$ of 1%, under and over excitation (off-line/on-line) limiters, field current regulation for manual control, auto tracking for bumpless transfer between any control modes and a communications Modbus protocol via a RS 485 serial port to aid control and streamline plant operations. Modbus communications provided a means to obtain metering, control, and annunciation from the excitation system.

Generator voltage matching was implemented that automatically caused the generator voltage to match the utility bus voltage to prevent bumps in synchronization. Voltage matching also reduced the time for synchronization, since operator intervention was no longer required.

Operating software is the key to commissioning the excitation system quickly and efficiently. Here, a customer-friendly Windows-based BESTCOMS operating software communication program utilized a

laptop computer for setup and commissioning, while testing tools included in the BESTCOMS aided startup and eliminated otherwise externally connected test equipment such as chart recorders. Features included are identified in the table on the last page.

The demolition included eliminating all the analog controls that made up the original excitation system except the rectifier bridges. See Figures 2 and 3.



Figure 2: Existing 3 SCR, 3 Diode Half-Wave Bridge



Figure 3: Original equipment parts removed during demolition



Figure 4: DECS-400 Installed in Cabinet Door

The Digital Controller was installed on the front door of the cabinet. See Figure 4. The special sequence panel included interposing relays, a programmable firing module, autotransformer for matching the existing power potential transformer secondary voltage to the firing circuit chassis, control transformer for the power supply, and a Field Isolation Module for monitoring generator field current and field voltage. A subpanel chassis was specially designed to fit on the back door in between the door channels. See Figure 5.



Figure 5: Back door of DECS-400 panel showing IFM Firing Circuit and related hardware

A gate amplifier board chassis was mounted in the cabinet interior back wall to amplify firing pulses and to ensure adequate energy from the firing circuit necessary to fire the gates of the power SCRs. Output contacts from the DECS-400 digital controller interfaced to the existing dc field flash contactor used for starting the machine. Figure 6 shows the cabinet lineup with the Digital Controller mounted. Figure 7 shows the partial schematic of the new interconnected system, highlighting the interface of the old and new hardware.



Figure 6: Exciter cabinet lineup with DECS-400 installed

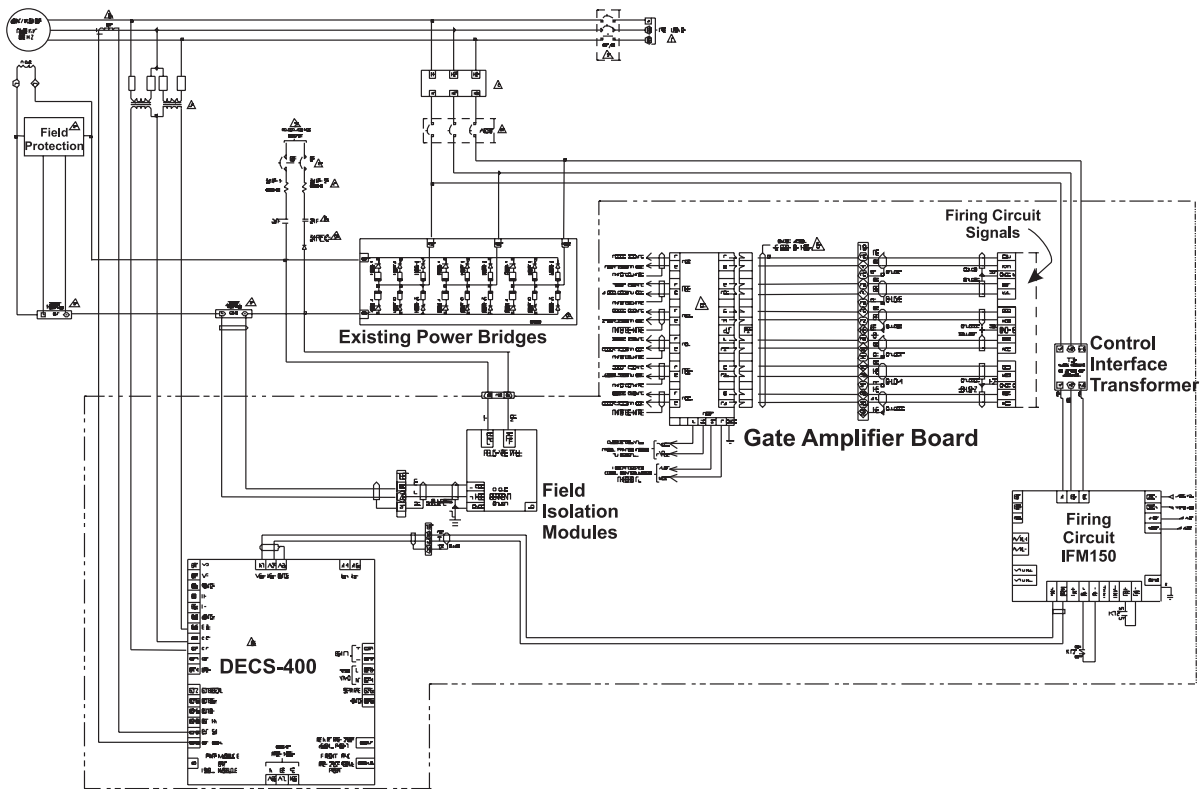

Figure 7: Partial schematic of the new interconnected system

A special interface transformer was used to match the power potential transformer secondary voltage to the required voltage of the new digital firing circuit. The digital firing module offered the flexibility of being programmed for various types of bridges, half wave or full wave SCR bridge operation. And for half wave bridges, programmable for SCRs located on either the positive or negative rail. See Figure 8.

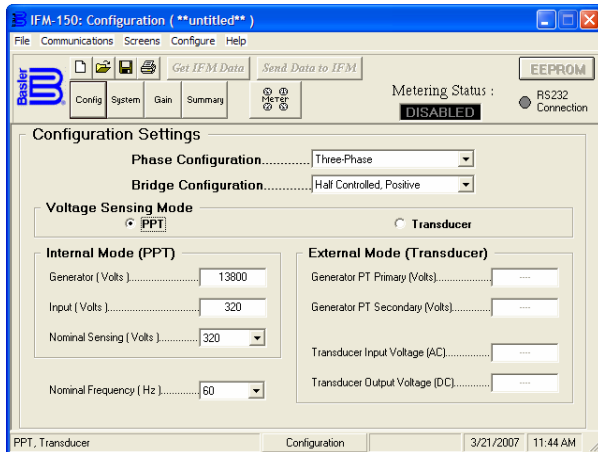

Figure 8: Firing Circuit setup for Half-Wave Bridge

After the installation, the wiring interface and checkout was completed and the excitation system and generator was ready to build voltage. The two-channel chart recorder in the BESTCOMS operating software was utilized to monitor voltage buildup and perform the voltage step tests needed to determine the excitation/generator performance. Figures 9 through 11 illustrate the screenshots resulting from data collected during commissioning. Unlike the older analog excitation systems that required voltage buildup in manual mode, the new excitation system safely built voltage in AVR mode without concerns of voltage overshoot due to windup.

Using the two (2) channel real time chart recorder, Figure 9 demonstrates the voltage buildup in voltage regulation mode. Note the smooth, stable operation as generator voltage builds up to nominal.

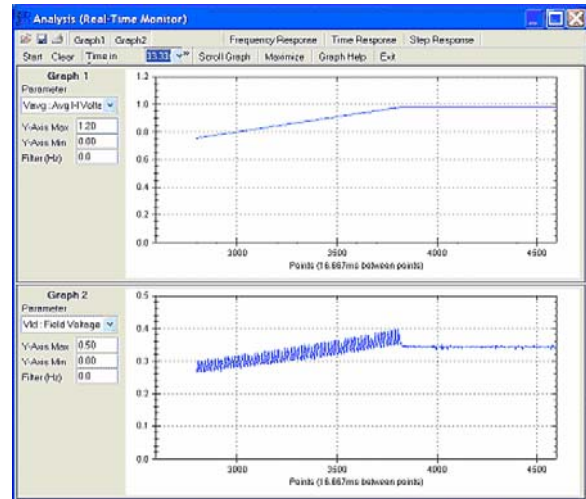

Figure 9: Voltage Buildup in Voltage Regulator Mode

Voltage step tests were performed to verify performance based on the selected gains for the digital controller. Here, the generator voltage responded within .3 seconds for a 5% voltage step change in the positive direction. See Figure 10. The analysis screen in BESTCOMS allows up to 10% voltage step tests to be performed, as well as time duration for the length of voltage step change. Comparing the performance with that of the old analog system, the new digital system exhibited approximately 5 times faster voltage response compared to its analog voltage regulator predecessor using the same power SCR bridge/s. Faster response translates into improved transient stability and generator relay coordination after a system disturbance.

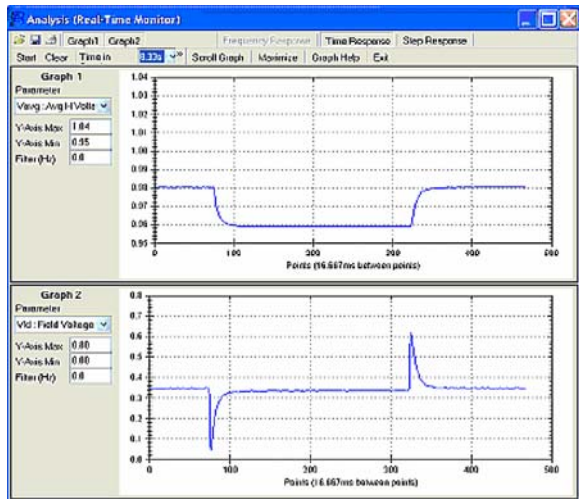

Figure 10: 5% Voltage Step Change in Voltage Regulator Mode

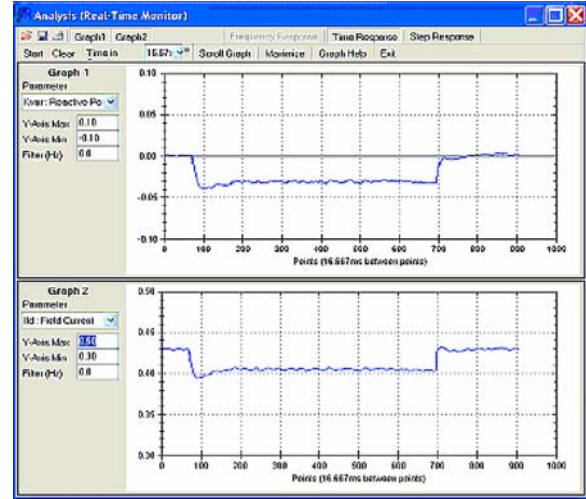

Figure 11: Under Excitation Limit Dynamic Step Test

Data is saved in the form of either a screenshot pasted into a word processing document or a data file for future record. Also available is oscillography that saves the information into an IEEE COMTRADE or log file.

Figure 11 demonstrates the operation of the Under Excitation Limiter (UEL) at a lower calibrated value to verify dynamic performance and stable operation.

Note that the performance for the UEL responds in less than 1 second with only a single, small underdamp swing. Upon conclusion of the commissioning, the excitation system was placed in Var Mode for normal operation.

CONCLUSION

The successful replacement of the analog controls with state of the art digital technology met the expectations of the project and enabled the generator and excitation system to be commissioned quickly and efficiently with new features to enhance the system's reliability for many more years of successful operation. Figures 12 and 13 illustrate a Basler SSE static exciter of the early 1980s being replaced with a digital front end while keeping the power bridge. Figure 14 illustrates a Siemens Allis Static Exciter before and after a digital front end replacement.



Figure 12: Using the analog technology; many lights, switches and meters on front of doors of a Basler SSE Static Exciter



Figure 13: New front door provided with new cutouts for DECS-400, a serial cable is used for a laptop connection.



Figure 14: The Lineup of the Siemens Allis Original Equipment; The DECS-400 digital controller installed on front of Siemens Allis Cabinet. Metering and obsolete switches were removed.

DIGITAL CONTROLLER INTEGRATED FEATURES, DECS-400

- Voltage Regulation: Better than 0.20% Accuracy
 - Other Operating Modes
 - Field Current Regulation
 - Var or Power Factor Control
- Automatic Nulling: Nulling between operating modes and redundant DECS
- Selectable Underfrequency or Volts/Hertz Ratio Limiter
- Minimum Excitation Limiter: Flexible 5 point map on real/reactive power axis or Internal generated UEL curve
- Maximum Excitation Limiter
- Dual PID Setting Groups: Allows for programmed changes in PID gain settings for use with Power System Stabilizer or alternate transmission systems

- Autovoltage Matching: Automatically matches generator voltage to bus voltage
- (2) Preposition Set points: Programmable for AVR, Manual, Var/PF Controller
- Reactive Droop or Line Drop Compensation
- Loss of Voltage Sensing: Transfers to manual control automatically due to loss of voltage sensing at the voltage regulator
- Oscillography: 600 points, 6 programmable parameters, holds up to 6 records
- Sequence of events: stores 127 records
- Real Time Monitoring (Chart Recorder for test analysis)
- Built-in Dynamic Analyzer for measuring frequency response of generator and excitation system
- Protection
 - Field Over Voltage
 - Generator Over/Under Voltage
 - Field Overcurrent
 - Loss of Voltage Sensing
 - Loss of Field
 - Volts/Hertz Protection
- Field over voltage, generator over/under voltage, field over current, and loss of field protections have dual set points selectable via programmable logic
- HMI providing Metering, Set point control, Alarm annunciation
- Irig B Time Synchronization stamp
- Generator Field Temperature Monitoring (Static Exciter)
- (2) Analog Transducers Outputs
- Optional Built-in Power System Stabilizer

- [4] R. C. Schaefer, Basler's SSE Analog Conversion to Digital Provides Feature Enhancements and Saves Cost of Power Bridge Replacement, *Application Note EX-SSE1*, Basler Electric, 2006.

REFERENCES

- [1] Front End Analog Conversion to Digital Saves Cost for Upgrades of Excitation System, Waterpower XV Conference, July 2007. J. Wilson, EWEB; R. Schaefer and Kiyong Kim, Basler Electric Company.
- [2] R. C. Schaefer, Excitation Upgrade Keeps Existing Power SCR Bridges and PPT, *Application Note EX-BRDG1*, Basler Electric, 2006.
- [3] R. C. Schaefer, DECS-400 Provides Front End Digital Control to GE Bus Fed Power Bridges, *Application Note EX-BUSFED*, Basler Electric, 2007.