	www.basler.com +1 618.654.2341 (USA) info@basler.com	Product	Excitation Support System
		Model	SBO 181 through SBO 185

APPLICATION

The Excitation Support System (Series Boost Option or SBO) provides motor starting and fault clearing capabilities for generators equipped with a brushless exciter. The Excitation Support System enables the use of a brushless generator in an application normally requiring a conventional generator with a brush-type rotary, PMG, or series-boost exciter.

Each Excitation Support System consists of a reservoir assembly (designated SBO 1XX) and a power current transformer (CT) selected to match the generator rating. The SBO reservoir assembly consists of electrical components mounted and wired on a sheet metal chassis. The CT is mounted externally and interconnected with the SBO assembly. Instructions for selection of the appropriate CT are provided later in this publication.

SBO assemblies are intended for use with an SR8A or SR8F voltage regulator or with a voltage regulator with an input power requirement of 240 Vac at 7 Aac. SBO reservoir assembly model applications are listed in Table 1.

Table 1. SBO Reservoir Assembly Model Application

Nominal System Voltage	Reservoir Assembly Model Designation	Part Number
208 to 240 Vac at 60 Hz	SBO 181	9037100100
416 to 480 Vac at 60 Hz	SBO 182	9037100101
208 to 240 Vac at 50 Hz	SBO 183	9037100103
416 to 480 Vac at 50 Hz	SBO 184	9037100104
575 to 600 Vac at 60 Hz	SBO 185	9037100102

An SBO reservoir assembly may also be used in a high-voltage application by using a power isolation transformer and special high-voltage power current transformer. For applications above 600 Vac, consult Basler Electric for transformer selection.

RESERVOIR ASSEMBLY SPECIFICATIONS

Power Dissipation

Approximately 300 W

Physical

Dimensions: See Figure 3
 Weight: 70 lb. (31.8 kg) net, 120 lb. (54.4 kg) shipping

Environment

Operating Temperature: -40 to 70°C (-40 to 158°F)
 Shock: Withstands 15 G in three perpendicular planes
 Vibration: Withstands 5G at 260 Hz

FUNCTIONAL DESCRIPTION

The Excitation Support System uses the principle of ferroresonance to provide a source of regulated voltage for the voltage regulator. The basic circuit is shown in Figure 1.

Publication	Revision	Instructions	Date	Copyright
903710099X	C		09/18	2018

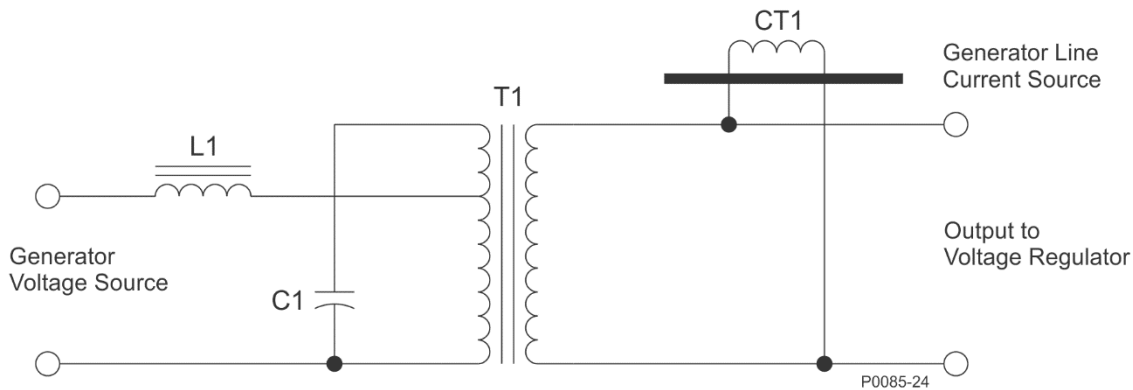

Figure 1. Excitation Support Basic Circuit Diagram

Excitation for the circuit is obtained from two sources: a voltage source and a current source. The generator output voltage serves as the voltage source and the current source is provided by the generator line current through the current transformer. Components T1, L1, and C1 form a basic transformer regulating circuit (reservoir assembly) driven only by a voltage source. The reservoir assembly supplies the power required by the generator field through the voltage regulator when the generator has no load. During no-load conditions, the reservoir assembly should not be required to supply more than 50% of the voltage regulator's total output capability.

Current transformer CT1 supplies the additional current required at generator full-load. CT1 receives excitation from two of the generator load lines and provides a current which is added vectorially to the current from the voltage source in the reservoir assembly. This enables the Excitation Support System to supply the current necessary to maintain maximum voltage regulator output. The exciter current necessary for motor starting and fault clearing is supplied entirely from the generator line current.

During short-circuit or motor starting conditions, the CT must supply the current required by the exciter field, plus 5 amperes required by the SBO to maintain ferroresonance. To obtain the required output, the turns ratio of the CT must be correct for the amount of generator line current flowing in the primary circuit. A wide range of turns ratios is available through various combinations of primary turns and secondary turns in the series of CTs designed for this application.

CT SELECTION

Use the following procedure to select the appropriate CT for your application.

1. Calculate the exciter field current supplied by the voltage regulator during generator short-circuit. Use the following equation:

$$I_1 = \frac{E}{R}$$

Where:

I_1 is the exciter field current

R is the exciter field resistance

E is the full-on/forcing voltage of the voltage regulator

During a short-circuit, the generator output voltage is zero. Since the regulator power stage is receiving normal voltage from the SBO output, it will be "full-on" delivering a maximum voltage output (180 volts). The amount of exciter field current that flows is a function of the exciter field resistance.

2. Use the generator short-circuit saturation data to determine the generator short-circuit line current that would result from the exciter field current calculated in step 1. The short-circuit saturation data is available from the generator manufacturer and is a plot of exciter field current versus line current with the generator output shorted.

If the result is acceptable generator line current, proceed to step 3.

If the result is excessive generator line current, proceed to step 4.

If the result is insufficient generator line current, use a voltage regulator with a greater field forcing capability.

Publication 903710099X	Revision C	Instructions	Date 09/18	Page 2 of 10
----------------------------------	----------------------	---------------------	----------------------	------------------------

3. Perform the following steps using the data listed in Table 2.

Table 2. CT Selection

Column 1 3-Phase Short-Circuit Line Current (Aac)	Column 2 When using a voltage regulator supplying this maximum exciter field current during short-circuit.							Column 3 CT Required
	2.5 Adc	3.4 Adc	4.4 Adc	5.6 Adc	6.9 Adc	8.4 Adc	10.0 Adc	
325	2:150		4:238		4:189		4:150	BE02462001
366		2:150		4:238		4:189		
408	2:189		2:150		4:238		4:189	
459		2:189		2:150		4:238		
515	2:238		2:189		2:150		4:238	
577		2:238		2:189		2:150		
651	1:150		2:238		2:189		2:150	
731		1:150		2:238		2:189		
818	1:189		1:150		2:238		2:189	
919		1:189		1:150		2:238		
1031	1:238		1:189		1:150		2:238	
1155		1:238		1:189		1:150		
1302	1:300		1:238		1:189		1:150	
1462		1:300		1:238		1:189		
1635	1:378		1:300		1:238		1:189	
1838		1:378		1:300		1:238		
2062	1:476		1:378		1:300		1:238	
2310		1:476		1:378		1:300		
2604	1:600		1:476		1:378		1:300	
2925		1:600		1:476		1:378		
3270	1:756		1:600		1:476		1:378	
3675		1:756		1:600		1:476		
4125	1:952		1:756		1:600		1:476	
4620		1:952		1:756		1:600		
5205	1:1200		1:952		1:756		1:600	
5850		1:1200		1:952		1:756		
6540			1:1200		1:952		1:756	
7350				1:1200		1:952		
8250					1:1200		1:1952	
9240						1:1200		
10410							1:1200	
CT Output at Short-Circuit	7.5 Aac	8.4 Aac	9.4 Aac	10.5 Aac	11.9 Aac	13.4 Aac	15 Aac	

- a. In column 1, locate the value determined in step 2 for the generator line current to be sustained during a short-circuit. (Use the closest value if the exact value cannot be located.) Using a straight edge, draw a horizontal line across the page immediately under the selected number.
- b. In column 2, locate the exciter field current calculated in step 1. (Use the closest value if the exact calculated value does not appear.) Draw a vertical line through this value to intersect with the horizontal line drawn in step 3a.
- c. Proceed to step 5.

4. Perform the following steps only if the result of step 2 is excessive generator line current.

- a. Determine what constitutes acceptable generator line current at short-circuit. This value is typically 250 to 300% nominal.
- b. Use the generator short-circuit saturation data to determine the exciter field current required to generate the acceptable generator line current just determined. To obtain this reduced current, a

current limiting resistor will need to be placed in series with the exciter field. Calculate the value of this resistor with the following equation:

$$R_s = \frac{E}{I_2} - R_f$$

Where:

R_s is the value of series field resistance to be added (in ohms)

E is 180 volts

I_2 is the field current required to produce acceptable generator line current during a short-circuit

R_f is the exciter field resistance

The series resistance must not be so great as to restrict normal forcing.

- c. In column 1 of Table 2, locate the value of acceptable generator line current at short-circuit (step 4a). (Use the closest value if the exact value cannot be located.) Using a straight edge, draw a horizontal line across the page immediately under the selected number.
 - d. In column 2, locate the exciter field current calculated in step 4b. (Use the closest value if the exact calculated value does not appear.) Draw a vertical line through this value to intersect with the horizontal line drawn in step 4c.
5. The point where the two lines intersect indicates the turns ratio of the required transformer. If the lines do not intersect a turns ratio, select the ratio directly above the intersection. From the turns ratio selected, move to the right within the same "stepped" area to determine the correct CT, identified in column 3.

The first number in the turns ratio indicates the number of turns of each generator feeder that must pass through the CT window. (The same number of turns on phase A and phase B is necessary.) The second number indicates the number of secondary turns. An increase in CT primary turns or a decrease in CT secondary turns results in increased CT power output. Selection of a lower turns ratio may result in the CT delivering slightly more secondary current than required. However, the SBO ferroresonant circuitry has the capacity to dissipate this energy. Table 4 identifies the available transformer secondary ratios.

CT Selection Example

The following example summarizes the method used to select the appropriate CT for an Excitation Support System application.

1. Calculate the current provided by a regulator during a generator short-circuit in a system with a 20 Ω field:

$$I_1 = \frac{E}{R} \quad I_1 = \frac{180 V}{20 \Omega} \quad I_1 = 9 A$$

2. From the data supplied by the generator manufacturer, you determine that a generator line current of 2,700 Aac would result from the 9 Adc output of the voltage regulator. You consider this level of generator current to be excessive.
3. You determine that 1,800 Aac would constitute an acceptable level of line current during generator short-circuit.
4. From data supplied by the generator manufacturer, you determine that an exciter field current of 6 Adc is required for the generator system to deliver 1,800 Aac during short-circuit. To obtain this reduced level of current, it will be necessary to place a current-limiting resistor in series with the exciter field. (See the calculation at the conclusion of this example.)
5. In column 1 of Table 2, locate the closest value of current to 1800 (1838). Draw a horizontal line under 1838 and across the remaining columns.
6. In column 2, locate the closest value of current to 6 (5.6 Adc). Draw a vertical line through 5.6 Adc which intersects with the horizontal line drawn in step 5. A turns ratio of 1:300 is intersected and will be used. Moving to the right from the turns ratio within the "stepped" area, you determine the appropriate CT to be part number BE02463001.

Calculation of Series Resistance

$$R_s = \frac{E}{I_2} - R_f \quad R_s = \frac{180}{6} - 20 \quad R_s = 10 \Omega$$

Publication 903710099X	Revision C	Instructions	Date 09/18	Page 4 of 10
----------------------------------	----------------------	---------------------	----------------------	------------------------

The series resistance must not be so great as to restrict normal forcing.

INSTALLATION

To ensure maximum performance and operation within the electrical specifications do not mount the reservoir assembly such that its terminal block is located at the top of the assembly.

Mounting

Figure 2 and Table 3 illustrate the mounting dimensions of the available CTs. Figure 3 illustrates the mounting dimensions of the reservoir assembly.

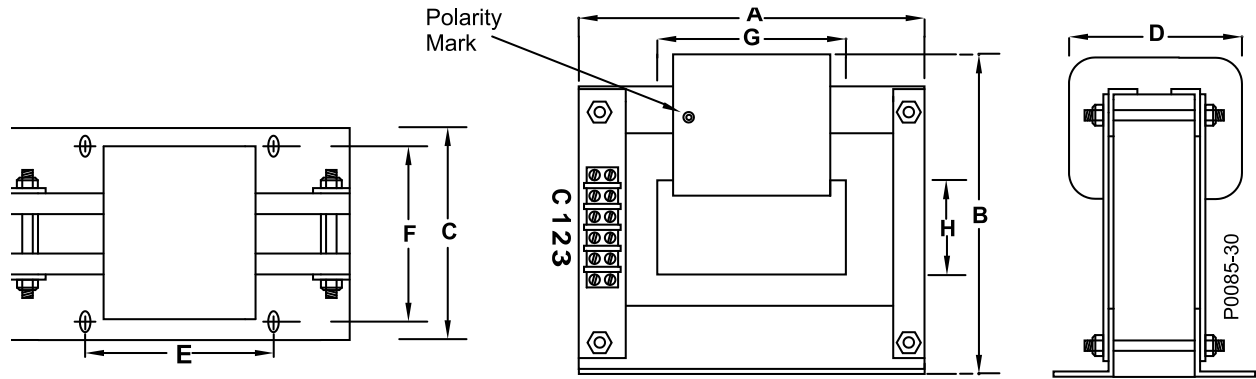
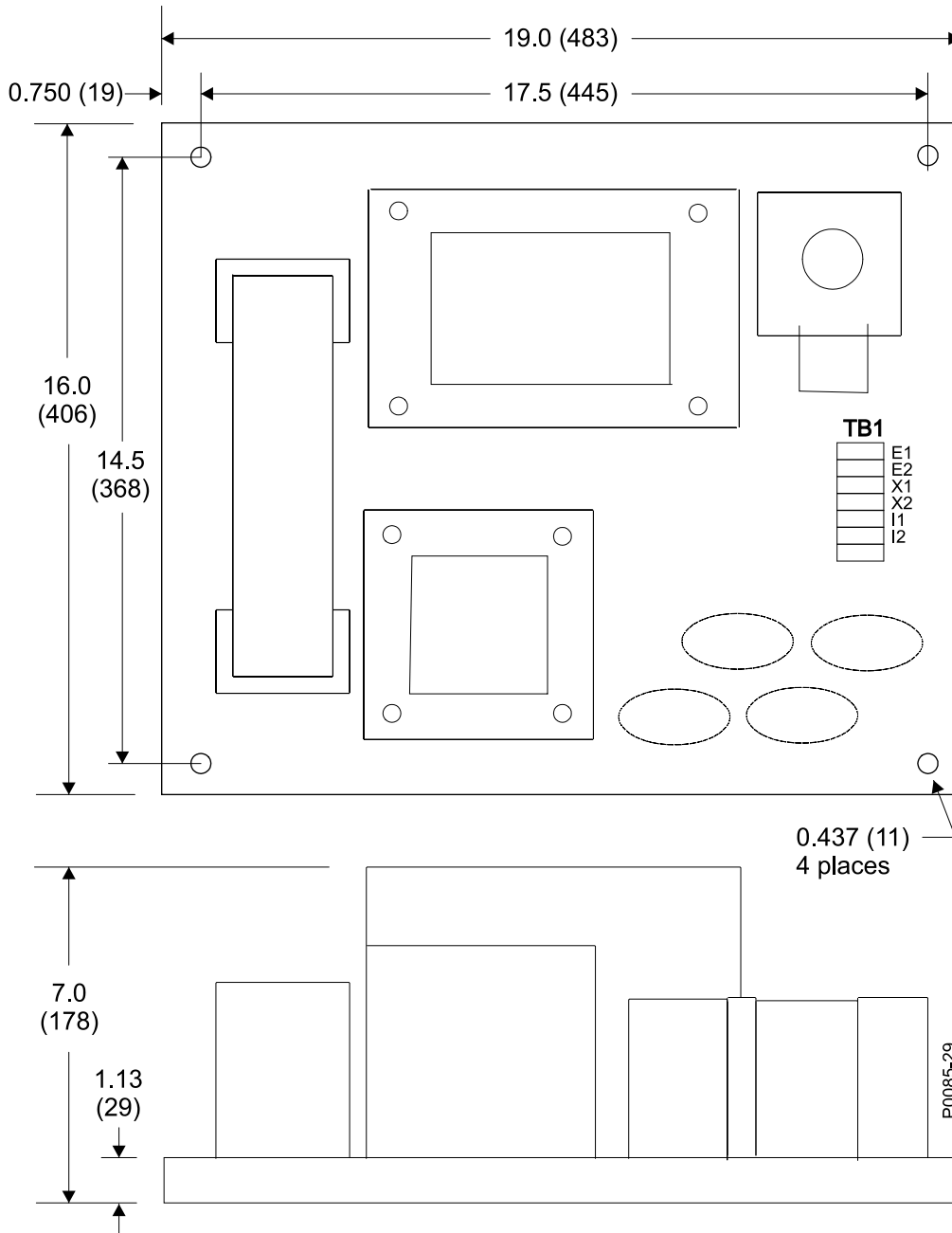

Figure 2. CT Dimensions

Table 3. CT Dimensions

CT P/N	Dimension							
	A	B	C	D	E	F	G	H
BE02462001	10.5 in. 267 mm	9.25 in. 235 mm	7.75 in. 197 mm	7.38 in. 187 mm	6.0 in. 152 mm	6.75 in. 171 mm	5.0 in. 127 mm	3.0 in. 76 mm
BE02463001	12.5 in. 318 mm	9.75 in. 248 mm	5.75 in. 146 mm	5.75 in. 146 mm	6.0 in. 152 mm	4.38 in. 111 mm	7.0 in. 178 mm	3.0 in. 76 mm
BE02464001	11.5 in. 292 mm	10.0 in. 254 mm	4.63 in. 118 mm	5.0 in. 127 mm	6.0 in. 152 mm	5.63 in. 143 mm	7.0 in. 178 mm	3.0 in. 76 mm



All dimensions in inches (millimeters).

Figure 3. SBO Chassis Dimensions

CONNECTIONS

Connect the Excitation Support System as shown in Figure 4 or Figure 5. Reservoir assembly schematic diagrams for the six SBO models are provided in Figure 6. The phase relationship between the SBO voltage and current inputs is critical. Incorrect phasing will prevent the Excitation Support System from maintaining sufficient current to the voltage regulator and poor regulation will result.

If the generator voltage is within the limits specified in Table 1, Excitation Support System power can be taken directly from the generator load lines. Isolation for the voltage regulator and exciter or generator field is provided by the Excitation Support System.

For generators rated above 600 Vac, a step-down power transformer must be used between the generator and Excitation Support System.

Publication 903710099X	Revision C	Instructions	Date 09/18	Page 6 of 10
----------------------------------	----------------------	---------------------	----------------------	------------------------

Basler Electric manufactures high-voltage current transformers, on special request, for use in 5 kVac and 15 kVac applications.

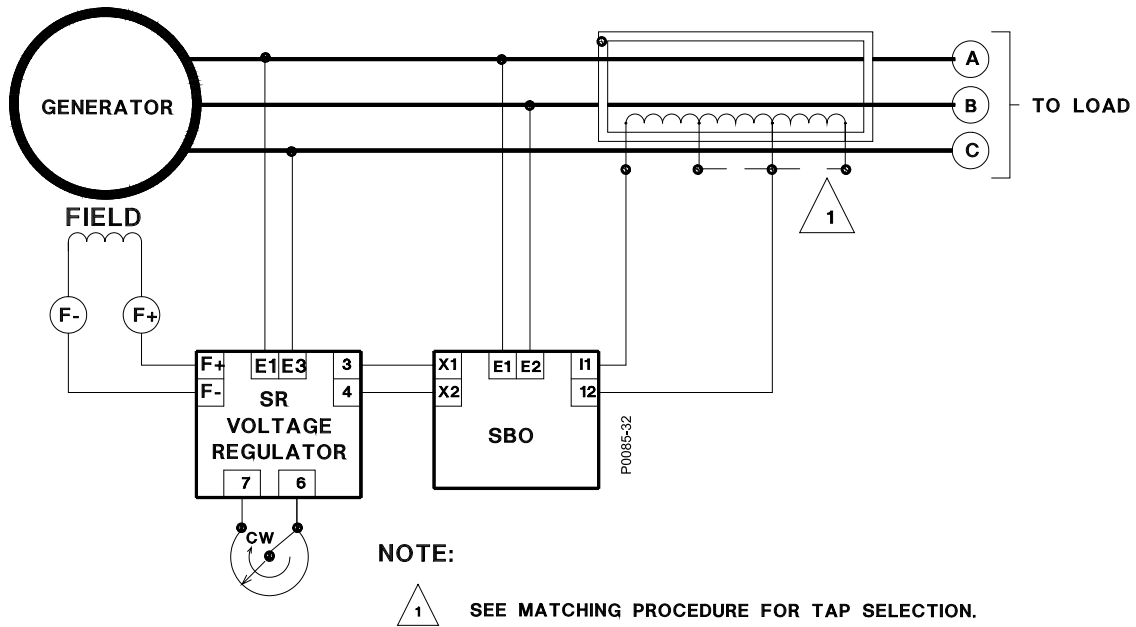

Figure 4. Interconnection, SBO and One CT

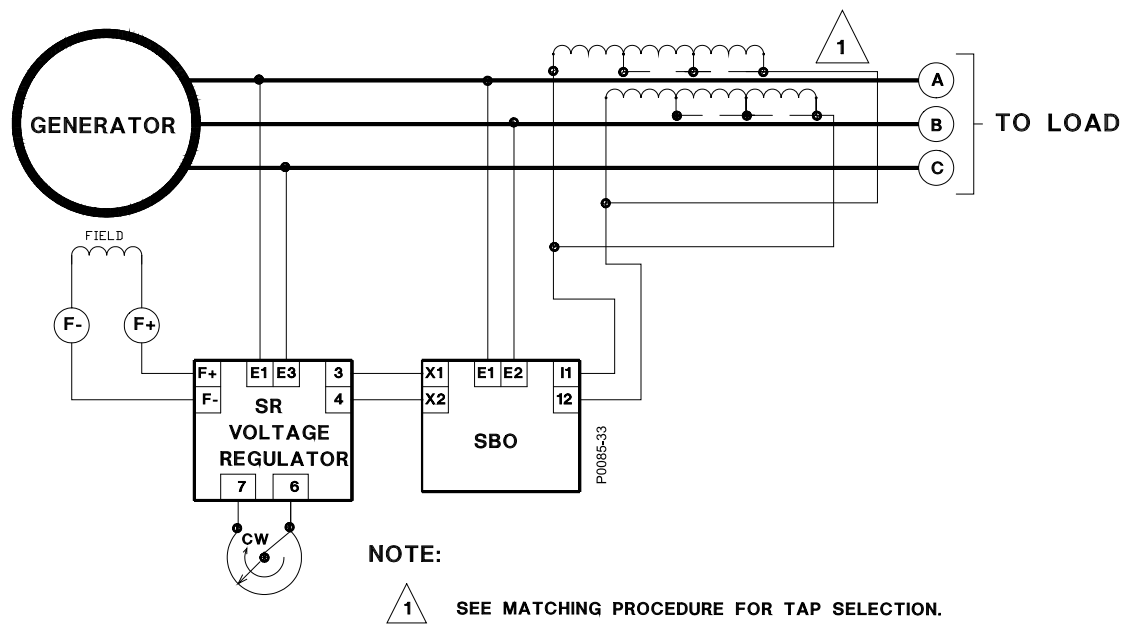
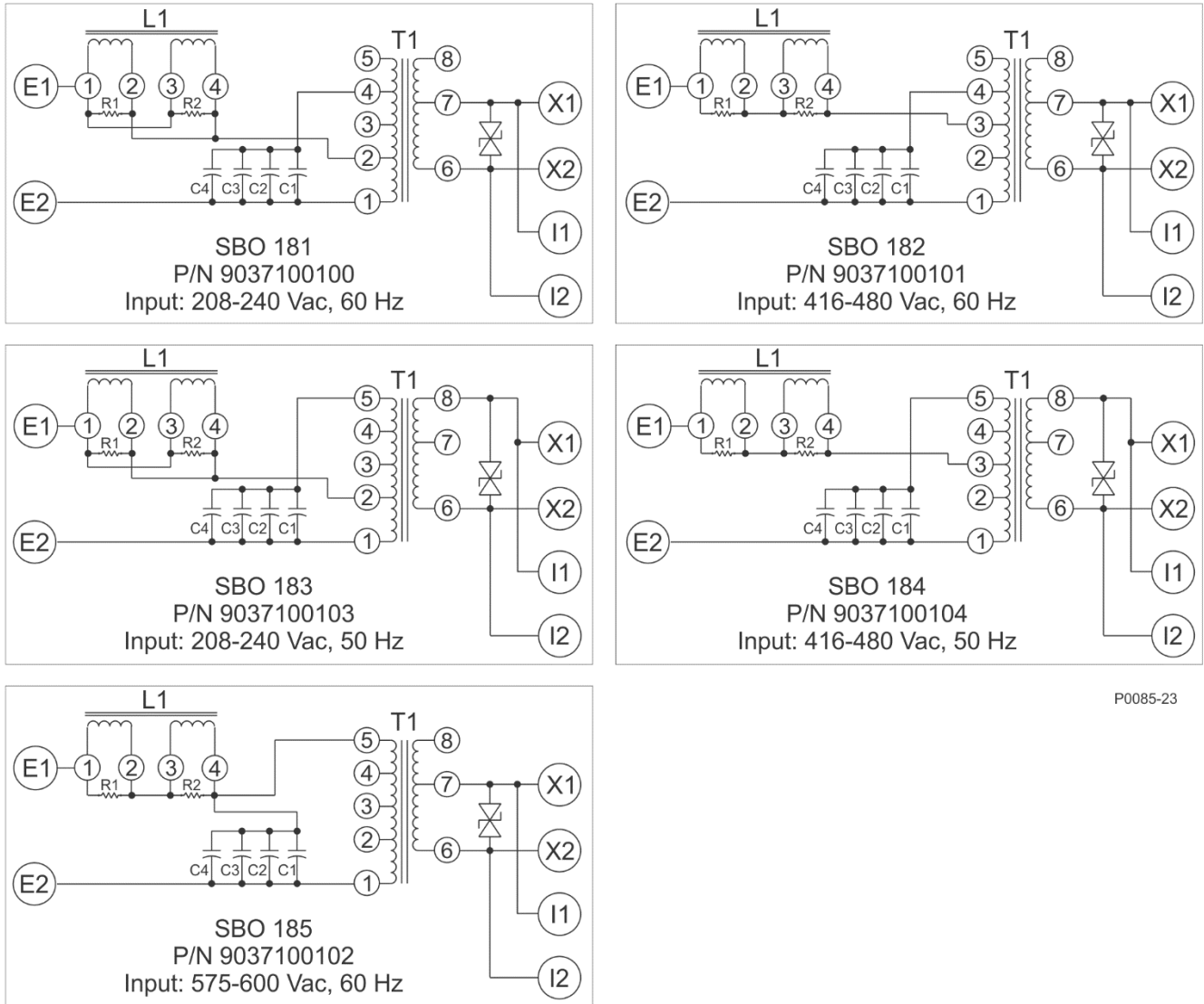

Figure 5. Interconnection, SBO and Two CTs



P0085-23

Figure 6. Schematic Diagrams, Reservoir Assemblies

CT Turns Ratios

CT connections and the corresponding turns ratios are provided in Table 4.

Table 4. CT Turns Ratios

CT P/N	Terminal C to 1	Terminal C to 2	Terminal C to 3	Terminal C to 4
BE02462001	150	189	238	N/A
BE02463001	300	378	476	N/A
BE02464001	600	756	952	1200

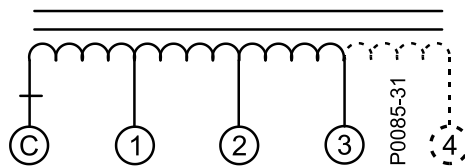

MAINTENANCE

No preventive maintenance is required other than periodic inspection. Ensure that all connections are clean and tight. Remove accumulations of dust with a soft brush or compressed air.

Troubleshooting

The following procedure can be used to test the Excitation Support System without applying a full-rated load. If a faulty SBO is suspected due to excessive heat generation from the SBO or poor regulation as the generator load is increased, proceed as follows.

1. Ensure correct interconnection by comparing the SBO connections with those of Figure 4 or Figure 5.
2. Attach a clamp-on ammeter to the primary input of the SBO, terminal E1 or E2.
3. Vary the generator kW load between 20% and 100% of rated. If full load cannot be achieved, vary the kW load between 20% and the highest percentage obtainable. Monitor the input current while varying the kW load.
4. Calculate the change in current through E1 or E2 with respect to the kW loading using the data taken in step 3 and the following equation.

$$M = \frac{\text{Percent Change of Current}}{\text{Percent Change of kW}} = \frac{kW_L(I_H - I_L)}{I_L(kW_H - kW_L)}$$

Where:

M is the percentage change in current (through E1 or E2) of the SBO for each percentage change in kW

I_H is the current through E1 or E2 at the highest percentage of rated kW rating

I_L is the current through E1 or E2 at the 20% point of rated kW load

$\%kW_H$ is the percentage of rated kW load achieved for the high reading

$\%kW_L$ is 20% of rated kW load

5. The calculated value of M should not exceed 0.375. If it does, one of the following problems is likely:
 - a. Incorrect phasing or polarity of the current/voltage in the SBO. Inspect the SBO connections and make any needed corrections.
 - b. Incorrect selection of the CT ratio for the SBO. Perform the procedure of *CT Selection* to evaluate if the selected CT is appropriate.
 - c. The SBO is faulty.

Renewal Parts

SBO components with maintenance significance are listed in Table 5. When ordering parts, provide the part number for the requested component as well as the SBO assembly.

Table 5. SBO Renewal Parts

Component Designator	Description	Basler P/N	Qty
T1	Transformer, prior to S/N 286 Transformer, S/N 286 and later	BE02442001 BE02442002	1 1
L1	Reactor, prior to S/N 286 Reactor, S/N 286 and later	BE02443001 BE02443002	1 1
C1, C2, C3, C4	Capacitor, 6 μ F, 660 Vac	04874	4
R1, R2	Resistor, 150 Ω , 200 W	03717	2
CR1	Surge arrestor	07145	1

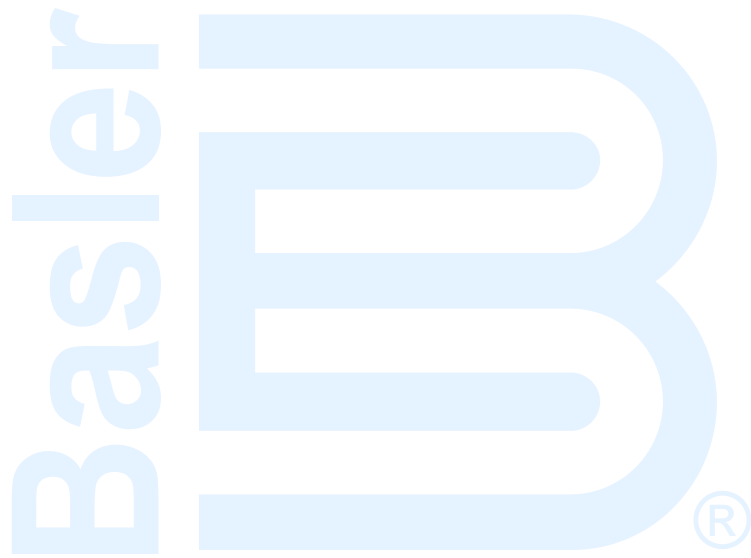

Publication 903710099X	Revision C	<i>Instructions</i>	Date 09/18	Page 10 of 10
----------------------------------	----------------------	----------------------------	----------------------	-------------------------