

INSTRUCTION MANUAL

FOR

RA-70

Reference Adjuster

92522001XX



Publication: 9252200990

Revision: S Sep-17

Preface

This instruction manual provides information about the installation and operation of the RA-70 Reference Adjuster. To accomplish this, the following information is provided:

- General information
- Theory of operation
- Installation information
- Operating instructions
- Maintenance and calibration
- Specifications

Conventions Used in this Manual

Important safety and procedural information is emphasized and presented in this manual through warning, caution, and note boxes. Each type is illustrated and defined as follows.

Warning!

Warning boxes call attention to conditions or actions that may cause personal injury or death.

Caution

Caution boxes call attention to operating conditions that may lead to equipment or property damage.

Note

Note boxes emphasize important information pertaining to installation or operation.



12570 State Route 143
Highland IL 62249-1074 USA

www.basler.com

info@basler.com

Tel: +1 618.654.2341

Fax: +1 618.654.2351

© 2017 by Basler Electric

All rights reserved

First printing: April 1992

Warning!

READ THIS MANUAL. Read this manual before installing, operating, or maintaining the RA-70. Note all warnings, cautions, and notes in this manual as well as on the product. Keep this manual with the product for reference. Only qualified personnel should install, operate, or service this system. Failure to follow warning and cautionary labels may result in personal injury or property damage. Exercise caution at all times.

Caution

This product contains one or more *nonvolatile memory* devices. Nonvolatile memory is used to store information (such as settings) that needs to be preserved when the product is power-cycled or otherwise restarted. Established nonvolatile memory technologies have a physical limit on the number of times they can be erased and written. In this product, the limit is 10,000 erase/write cycles. During product application, consideration should be given to communications, logic, and other factors that may cause frequent/repeated writes of settings or other information that is retained by the product. Applications that result in such frequent/repeated writes may reduce the useable product life and result in loss of information and/or product inoperability.

Basler Electric does not assume any responsibility to compliance or noncompliance with national code, local code, or any other applicable code. This manual serves as reference material that must be well understood prior to installation, operation, or maintenance.

For terms of service relating to this product and software, see the *Commercial Terms of Products and Services* document available at www.basler.com/terms.

This publication contains confidential information of Basler Electric Company, an Illinois corporation. It is loaned for confidential use, subject to return on request, and with the mutual understanding that it will not be used in any manner detrimental to the interests of Basler Electric Company and used strictly for the purpose intended.

It is not the intention of this manual to cover all details and variations in equipment, nor does this manual provide data for every possible contingency regarding installation or operation. The availability and design of all features and options are subject to modification without notice. Over time, improvements and revisions may be made to this publication. Before performing any of the following procedures, contact Basler Electric for the latest revision of this manual.

The English-language version of this manual serves as the only approved manual version.

Contents

Introduction	1
Style Charts	1
Theory of Operation	5
RA-70A and RA-70P Theory of Operation	5
Phone Jack/Serial Link Circuit	5
Pushbutton/Contact Inputs Circuit	5
4 to 20 mA / 0 to 10 Vdc (Programmable Logic Control) Input Circuit	5
Power Supply Circuit.....	6
Output Circuits	6
Metering Output Circuits	6
Pre-Positioning Function.....	6
RA-70M Theory of Operation	6
Nulling/Autotracking Input Circuits.....	6
Pushbutton/Contact Inputs Circuit	6
Phone Jack/Serial Link Circuit.....	6
4 to 20 mA / 0 to 10 Vdc (Programmable Logic Control) Input Circuit	7
Power Supply Circuit.....	7
Output Circuits	7
Metering Output Circuits	7
Pre-Positioning Function.....	7
Installation	9
Mounting.....	9
Reference Adjuster	9
Meters	10
Isolation Transformer	12
Connections.....	12
Operation	19
Raise/Lower Functions	19
Pre-Position 1 and 2 Functions	20
Mode Control Functions	21
Mode 0 (All Styles).....	21
Mode 0 (Model RA-70M Only)	21
Mode 1 (0 - 10 V) (All Styles).....	22
Mode 2 (4 - 20 mA) (All Styles).....	22
Mode 3 (SSE) (Model RA-70M Only)	22
Mode 4 (0 - 10 V) (All Styles).....	22
Mode 5 (4 - 20 mA) (All Styles).....	23
Maintenance and Calibration for Units Prior to Serial Number 958	25
Preventive Maintenance	25
Corrective Maintenance.....	25
Warranty and Repair Service	25
Calibration	25
Pre-Position	25
Preliminary Instructions	26
High Limit Setpoint Programming	26
Low Limit Setpoint Programming.....	26
Pre-Position 1 Setpoint Programming	27
Pre-Position 2 Setpoint Programming	27
Pre-Position Type Programming.....	28
Autotracking Response Delay Programming.....	29
Input Mode Programming	30
Traverse Rate Programming	31
Calibration - Quick Reference	32

Maintenance and Calibration for Units after Serial Number 958.....	35
Preventive Maintenance	35
Corrective Maintenance.....	35
Warranty and Repair Service	35
Calibration	35
Preliminary Instructions	36
High Limit Setpoint Programming.....	36
Low Limit Setpoint Programming.....	36
Pre-Position 1 Setpoint Programming	37
Pre-Position 2 Setpoint Programming	37
Pre-Position Type Programming.....	38
Autotracking Response Delay Programming.....	39
Input Mode Programming	40
Traverse Rate Programming	41
Traverse Mode Programming	42
Traverse Mode.....	43
Calibration - Quick Reference	43
Specifications	47
Operational Specifications.....	47
Input Power	47
Input Burden	47
Input Sensing	47
Input Control	47
Outputs	47
Accuracy	47
Resolution	47
Traverse Time.....	47
Operating Control Range.....	47
Autotracking	47
Nullmeter Output.....	48
Position Indicator Output	48
General Specifications.....	48
Hipot.....	48
Surge Withstand Capability	48
Temperature	48
Shock	48
Vibration.....	48
UL Recognition	48
Weight.....	48
Revision History	49

Introduction

The Basler Microprocessor-Based Reference Adjuster, Model RA-70, replaces Motor Operated Potentiometers and provides a totally solid-state method of adjusting the setpoint on Basler Automatic Voltage Regulators (AVRs), Basler Shunt Static Exciter-Regulators (SSEs), Basler Manual Voltage Controls (MVCs), the Basler Var/Power Factor Controller (SCP-250) and other input devices having a rheostat or potentiometer type control adjustment. The unit is designed for "behind-the-panel" mounting in switchgear or control boxes. All controls, inputs, outputs, and LED indicators are located on the unit's front panel for ease of installation and adjustment. The RA-70 Reference Adjuster also comes equipped with a 0-1 mA output signal to operate a position indicator that will indicate the setpoint position.

The Reference Adjuster is completely compatible with the following Basler equipment:

- Shunt Static Exciter-Regulator (SSE), both for automatic and manual adjust functions
- SSR series of Voltage Regulators
- SR-A, SR-E, SR-H, and SR-F series of Voltage Regulators
- APR series of Voltage Regulators
- AVC63-12 and AVC125-10 Voltage Regulators
- MVC-112, MVC-236, and MVC-301 Manual Voltage Controls

The Reference Adjuster is capable of being interfaced with the above listed items and with the following Basler system control devices:

- Minimum/Maximum Excitation Limiter (EL-200)
- Var/Power Factor Controller (SCP-250)
- Underfrequency/Overvoltage Module (UFOV-260)

The Reference Adjuster can be used for almost any application where rheostat or potentiometer output is required.

1. For a rheostat output, match the ohmic output from the Style Chart (Figure 1) for the RA-70A model.
2. For a potentiometer output, match the ohmic output from the Style Charts (Figures 2 and 3) for the RA-70M or RA-70P models.

Note

For resistance values not shown, contact the Technical Sales Support department at the Basler Electric facility in Highland, Illinois.

Style Charts

The complete model number of the Reference Adjuster is a combination of letters and numbers indicating the features which are included. Figure 1 is the style chart for Reference Adjusters Having a Voltage Regulator Interface. Figure 2 is the style chart for Reference Adjusters having a Manual Voltage Control Interface. Figure 3 is the style chart for Reference Adjusters having a VAR/Power Factor Control Interface. For example, a Reference Adjuster used with a Voltage Regulator may have a model number of **RA-70 A SC1R**. This RA-70 would have the following features:

- A) A voltage regulator interface is used
- S) 24 Vdc is used for input power
- C) The control input is 4 - 20 mA
- 1) The type of voltage regulator - SR-F, SR-E/H, SSE
- R) Dual reference signals are output for twin AVRs

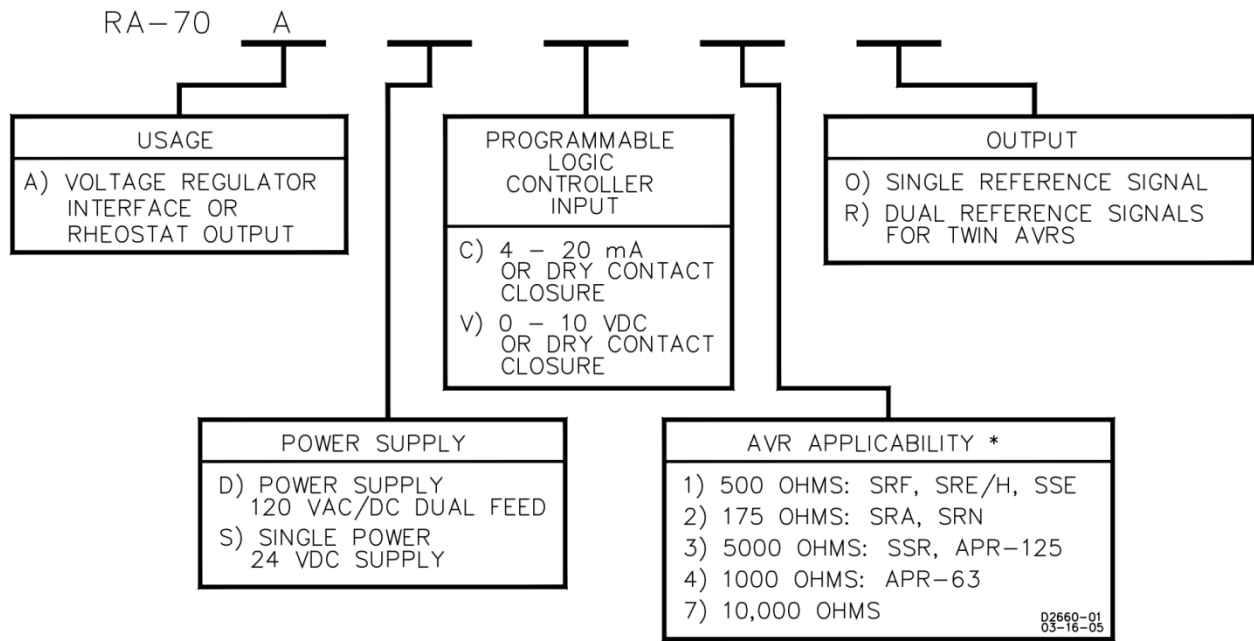

* An RA-70P (10,000 ohms) is recommended for voltage setpoint control of an AVC63-12 or AVC125-10 voltage regulator. This will ensure that a voltage raise and lower command corresponds to a generator voltage increase or decrease respectively.

Figure 1. Style Chart for Reference Adjuster Used with a Voltage Regulator Interface

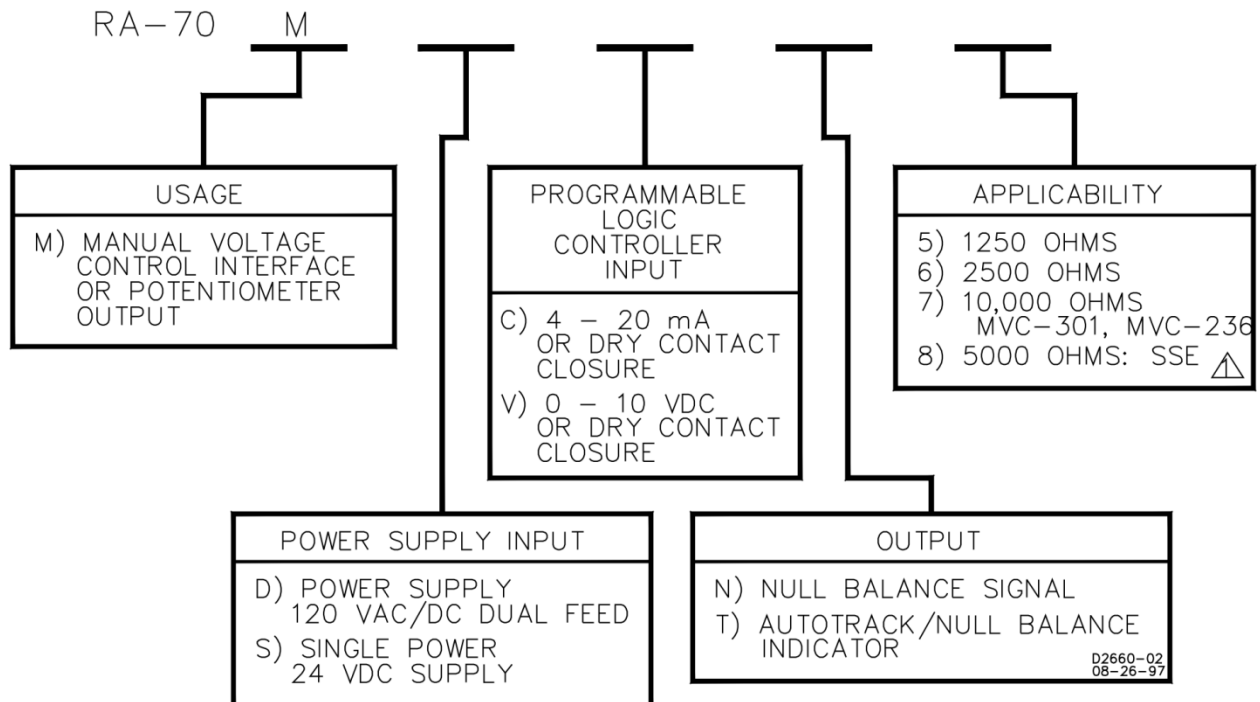

△ If Applicability option is 8, Programmable Logic Controller Input option must be V.

Figure 2. Style Chart for Reference Adjuster Used with Manual Voltage Control Interface

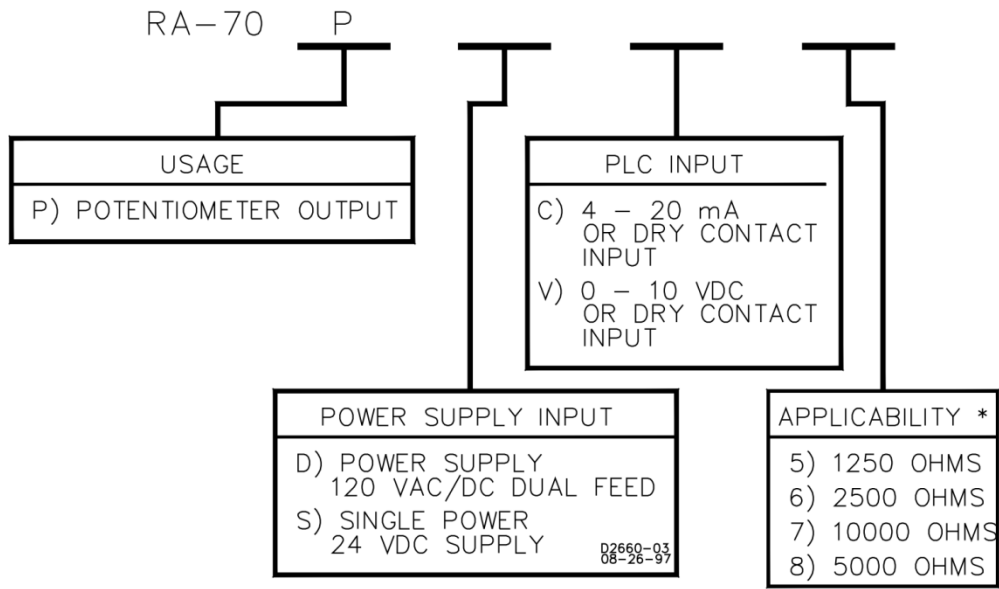

* An RA-70P (10,000 ohms) is recommended for voltage setpoint control of an AVC63-12 or AVC125-10 voltage regulator. This will ensure that a voltage raise and lower command corresponds to a generator voltage increase or decrease respectively.

Figure 3. Style Chart for Reference Adjuster Used with a Var/Power Factor Control Interface



Theory of Operation

The Microprocessor-Based Reference Adjuster, Model RA-70, provides the same functions as a Basler Motor Operated Control but with the reliability and precision of a digital microprocessor. The reference adjuster has features which make it very user friendly for each system application.

There are three basic styles of the Reference Adjuster: RA-70A, RA-70P, and RA-70M.

1. The RA-70A provides a two-wire output that is typical of a rheostat control and is typically used with Basler voltage regulator systems.
2. The RA-70P provides a three-wire output that is typical of a potentiometer control.
3. The RA-70M provides a three-wire output that is typical of potentiometer circuits. The RA-70M also has the capability to sense the outputs of a voltage regulator and a manual voltage control in order to provide a null signal for "bumpless" transfer between two operating modes.

RA-70A and RA-70P Theory of Operation

Both the RA-70A and RA-70P operate in a similar manner. The basic difference between the two units is the type of resistance output as described above. Refer to Figure 4 for the following discussion.

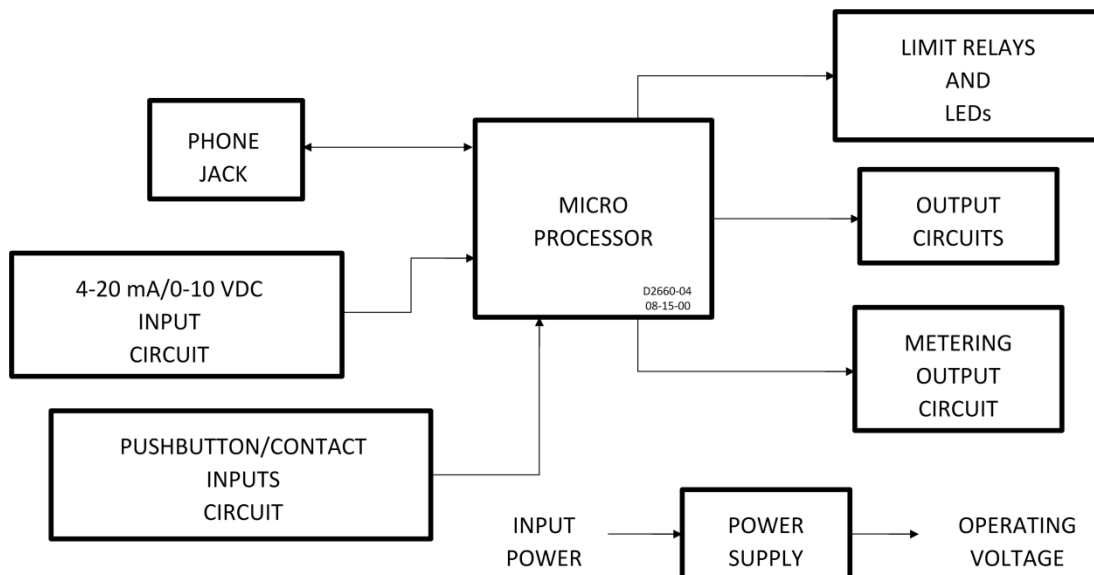

Figure 4. RA-70A and RA-70P Block Diagram

Phone Jack/Serial Link Circuit

This circuit is used only by the factory to program the unit for customer specified features.

Pushbutton/Contact Inputs Circuit

The pushbuttons (front panel switches) provide for front panel control over the Raise, Lower, Pre-position 1, Pre-position 2, Mode Select, and Programming functions. External dry contacts provide the same functions as the first four pushbuttons on the front panel except for the Programming function, which is available only by the use of the front panel pushbuttons. The contact inputs will allow remote control of the reference adjuster.

4 to 20 mA / 0 to 10 Vdc (Programmable Logic Control) Input Circuit

Programmable Logic Control by a 4 to 20 mA or 0 to 10 Vdc signal can be programmed into the Reference Adjuster to allow the unit to be controlled by a signal source instead of dry contacts. The

Raise/Lower input signal can be used to provide for either a threshold change input or a linear input. When the Reference Adjuster is controlled by the 4 to 20 mA or 0 to 10 Vdc input signal, the raise/lower contacts and pushbuttons are not recognized. See the *Maintenance Instructions* chapter for programming details.

Power Supply Circuit

The power supply is available in two different styles. The Type S power supply has a single source input which accepts only 24 Vdc. The Type D power supply has a dual input (redundant) which accepts both 125 Vdc and 120 Vac simultaneously. Thus, with a Type D power supply, if one of the two input voltages should fail, the reference adjuster will remain operational by using the other input voltage. Both types of power supplies provide all the internal operating power for the reference adjuster. Refer to the *Specifications* chapter for the input power requirements.

Output Circuits

This circuit provides the necessary control resistance to the various devices that the reference adjuster will control. Depending upon the type of application, the output will simulate a two-wire rheostat or a three-wire potentiometer. Refer to the style charts in the *Introduction* chapter for values and applicability.

Metering Output Circuits

These circuits provide the drive voltage or current to a remote position meter. See the *Installation* chapter for meter part numbers, mounting, and interconnection information.

Pre-Positioning Function

The reference adjuster provides a pre-position capability (i.e.: automatic return to the pre-set value of resistance). The Pre-Position function can be programmed to hold the reference adjuster output to a pre-programmed value while ignoring all raise/lower inputs until the Pre-Position function is turned off. The Pre-Position function can also be pre-programmed to allow the raise/lower inputs to control the reference adjuster output only after the pre-position setting has been attained.

RA-70M Theory of Operation

The RA-70M operates in a similar manner to the RA-70A and RA-70P. The basic differences are that the RA-70M is designed to provide a three-wire potentiometer compatible output and is used in conjunction with the Basler Manual Voltage Controls to provide an autotracking capability for "bumpless" transfer between the Auto and Manual operating modes of many exciter systems. A diagram showing the RA-70M function blocks is shown in Figure 5.

Nulling/Autotracking Input Circuits

This sensing circuit connects to the F+ and F- outputs of the AVR and to the F+ and F- outputs of the MVC. Both inputs are compared and the difference is sent to the microprocessor for processing and output as the nulling signal. If Autotracking is enabled, the null output will read zero as long as tracking is maintained. The field voltage range (32 Vdc, 63 Vdc, or 125 Vdc) is automatically selected. A front panel LED lights whenever the AVR and MVC are nulled.

Pushbutton/Contact Inputs Circuit

The pushbuttons (front panel switches) provide for front panel control over the Raise, Lower, Pre-position 1, Pre-position 2, Mode Select, and Programming functions. External dry contacts provide the same functions as the first four pushbuttons on the front panel except for the Programming function, which is available only by the use of the front panel pushbuttons. The contact inputs allow remote control of the reference adjuster.

Phone Jack/Serial Link Circuit

This circuit is used only by the factory to program the unit for customer specified features.

4 to 20 mA / 0 to 10 Vdc (Programmable Logic Control) Input Circuit

Programmable Logic Control by a 4 to 20 mA or 0 to 10 Vdc signal can be programmed into the reference adjuster to allow the unit to be controlled by a signal source instead of dry contacts. The Raise/Lower input signal can be used to provide for either a threshold change input or a linear input. See the *Maintenance Instructions* chapter for programming details.

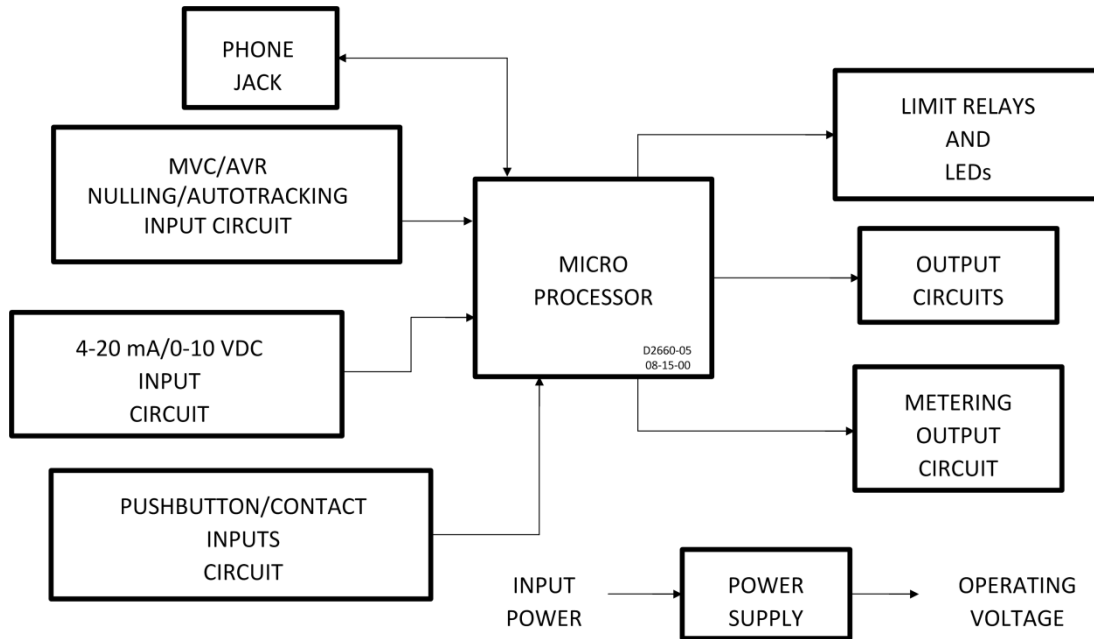

Figure 5. RA-70M Block Diagram

Power Supply Circuit

The power supply is available in two different styles. The Type S power supply has a single source input which accepts only 24 Vdc. The Type D power supply has a dual input (redundant) which accepts both 125 Vdc and 120 Vac simultaneously. Thus, with a Type D power supply, if one of the two input voltages should fail, the reference adjuster will remain operational by using the other input voltage. Both types of power supplies provide all the internal operating power for the reference adjuster. Refer to the *Introduction* chapter for the input power requirements.

Output Circuits

This circuit provides the necessary control resistance to the various devices that the Reference Adjuster will control. The output will simulate a three-wire potentiometer. Refer to the style chart in the *Introduction* chapter for values and applicability.

Metering Output Circuits

These circuits provide the null meter signal to a remote null meter. Refer to the *Installation* chapter for meter part numbers, mounting, and interconnection information.

Pre-Positioning Function

The reference adjuster provides a Pre-Position capability (i.e.: automatic return to the pre-set value of resistance). The Pre-Position function can be programmed to hold the reference adjuster output to a pre-programmed value while ignoring all raise/lower inputs until the Pre-Position function is turned off. The Pre-Position function can also be pre-programmed to allow the raise/lower inputs to control the reference adjuster output only after the Pre-Position setting has been attained.

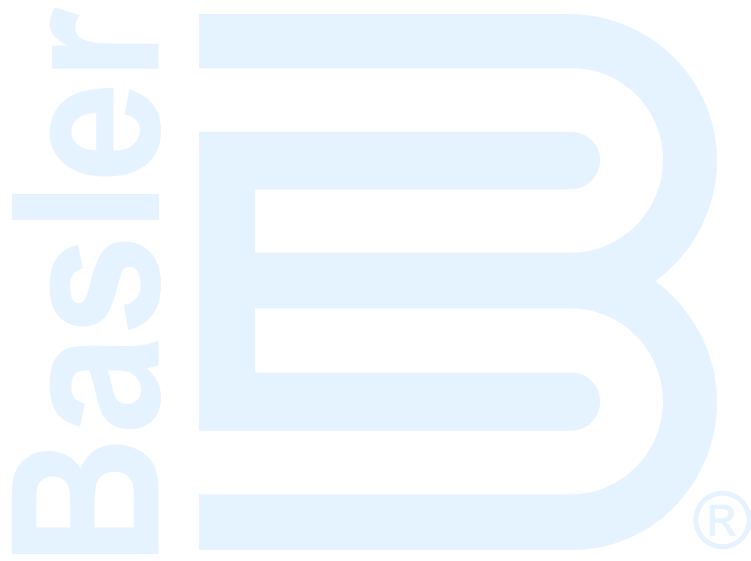

Installation

Mounting

Reference Adjuster

The Reference Adjuster is convection cooled and should not be mounted near heat-generating equipment or inside fully enclosed switchgear where the temperature rise could exceed its operating limit. Vertical mounting is recommended to obtain optimum convection cooling. RA-70 dimensions are shown in Figure 6.

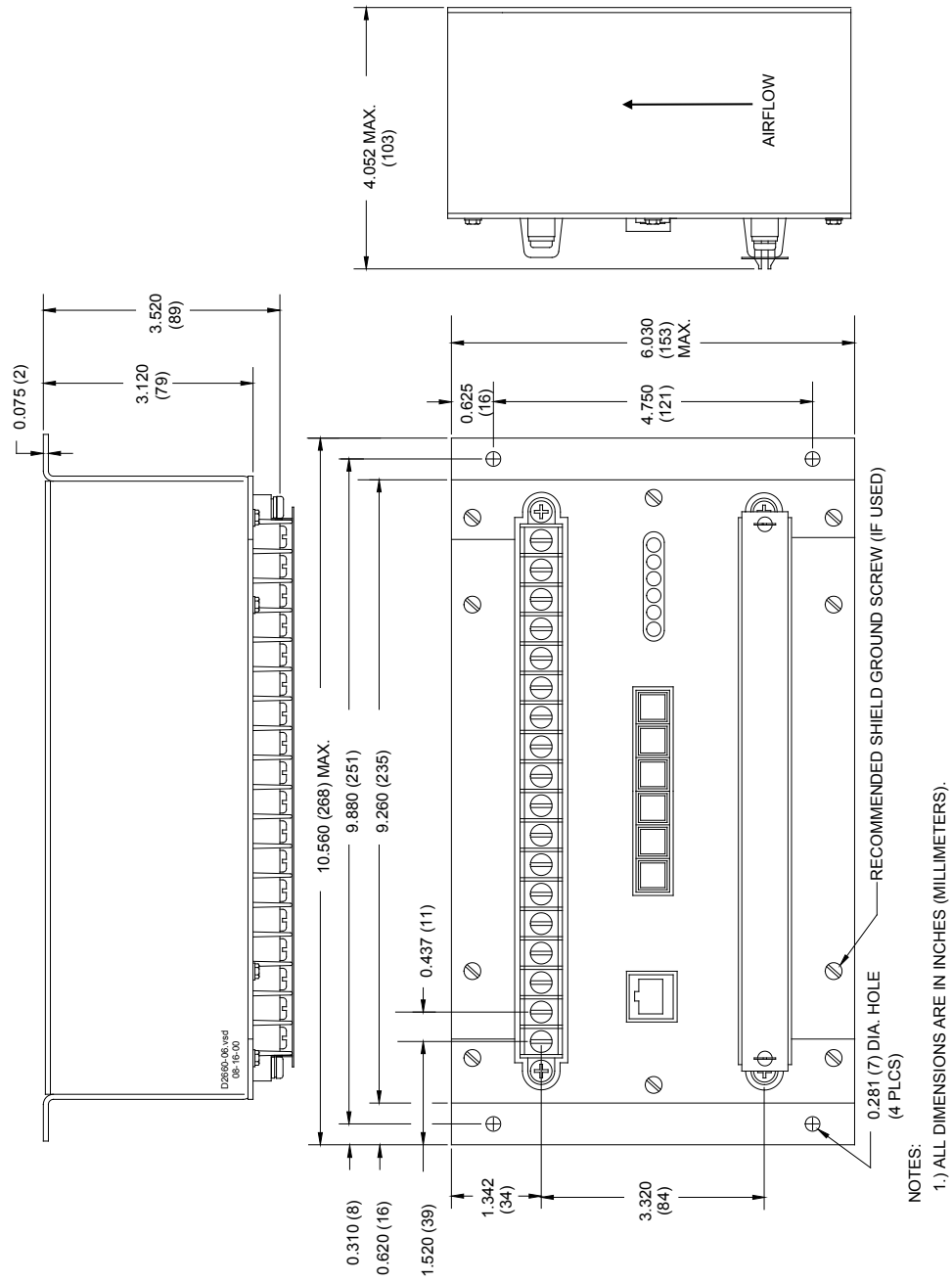

Figure 6. RA-70 Outline Dimensions

Meters

An optional null meter and position meter are available from Basler Electric for use with the RA-70.

Null Meter

Two styles of null meter are available: a panel type (Basler p/n 27832) and a switchboard panel type (Basler p/n 23332). An outline drawing for the switchboard null meter is shown in Figure 7. An outline drawing for the panel type null meter is shown in Figure 8.

Position Meter

Two styles of position meter are available: a panel type (part number 27825) and a switchboard panel type (part number 27824). Both meters are rated for 0 to 1 mA and 5 kΩ burden. An outline drawing for the switchboard position meter is shown in Figure 7. An outline drawing for the panel type position meter is shown in Figure 9.

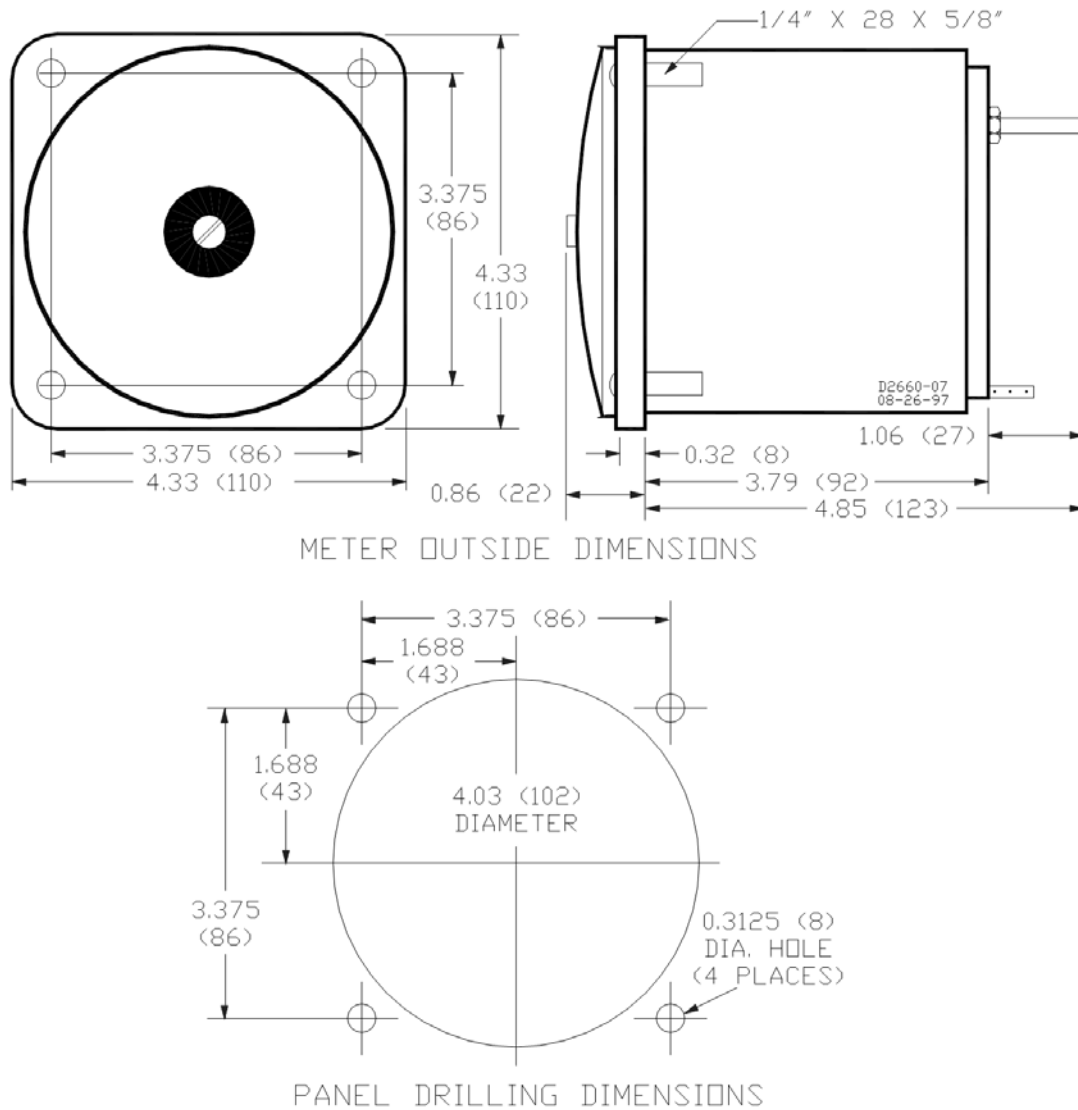

Figure 7. Outline Drawing, Switchboard Type Meter

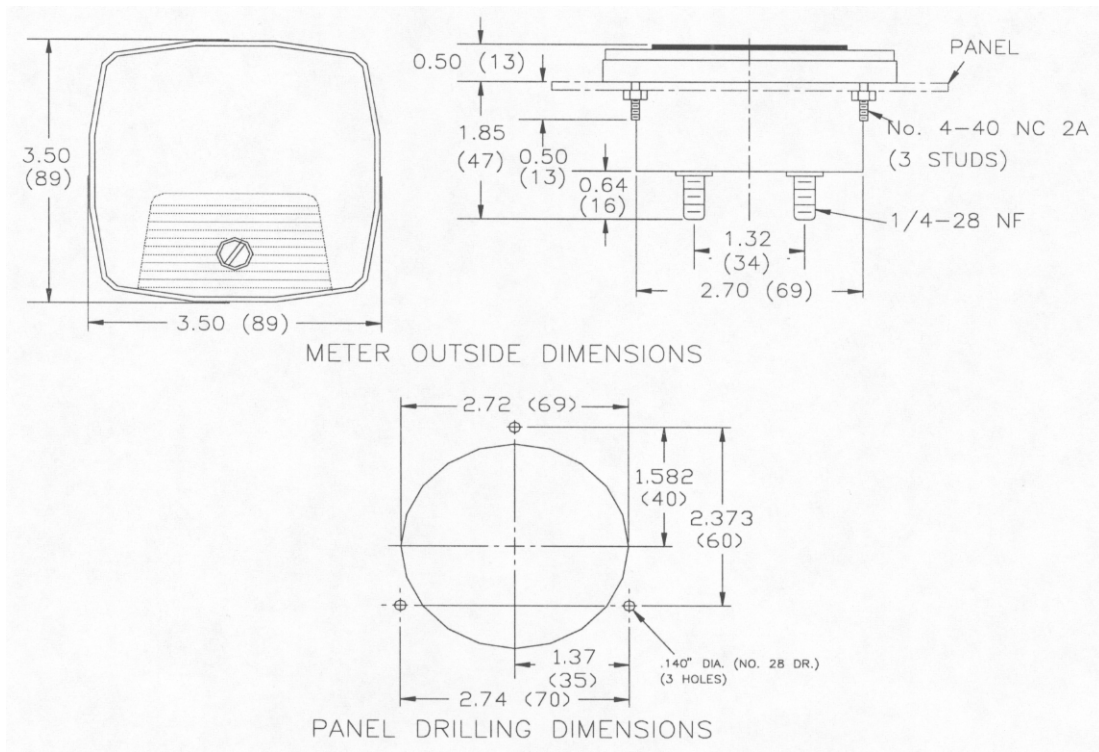

Figure 8. Outline Drawing, Panel Type Null Meter

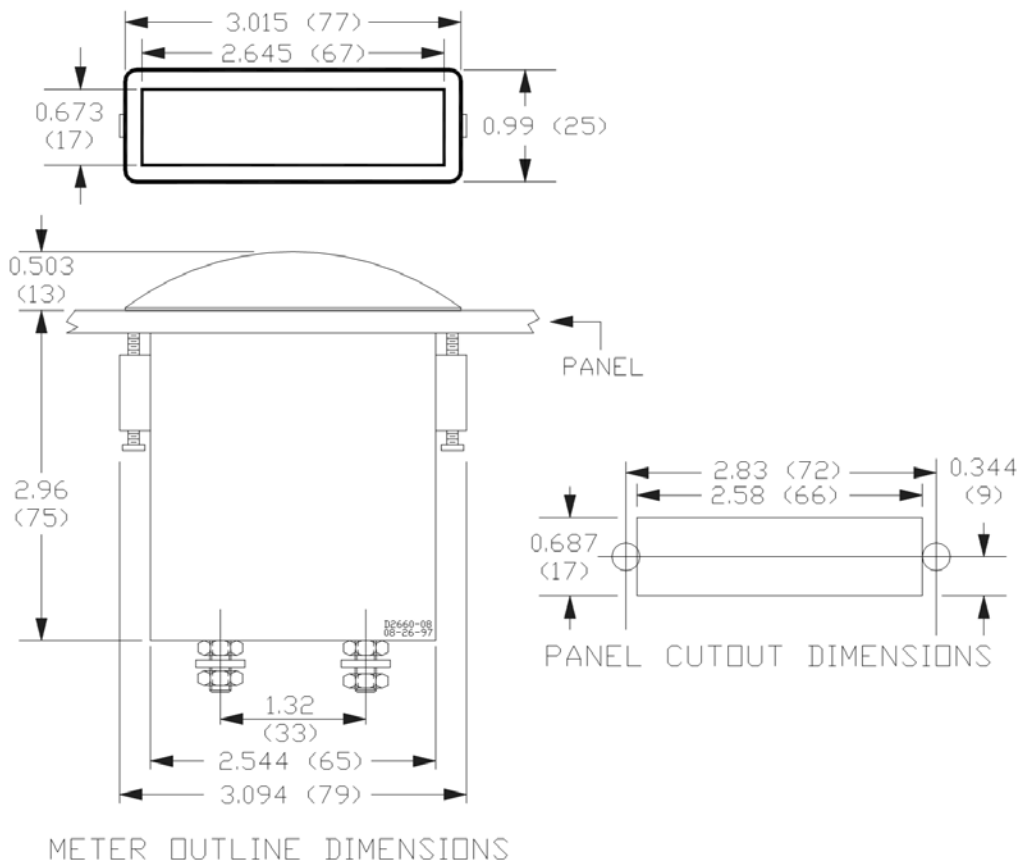

Figure 9. Outline Drawing, Panel Type Position Meter

Isolation Transformer

A 120 Vac to 120 Vac, 50 VA isolation transformer (Basler p/n BE25982) is available from Basler Electric to provide input power if the dc input on dual-feed power supply models is grounded. Transformer dimensions are shown in Figure 10.

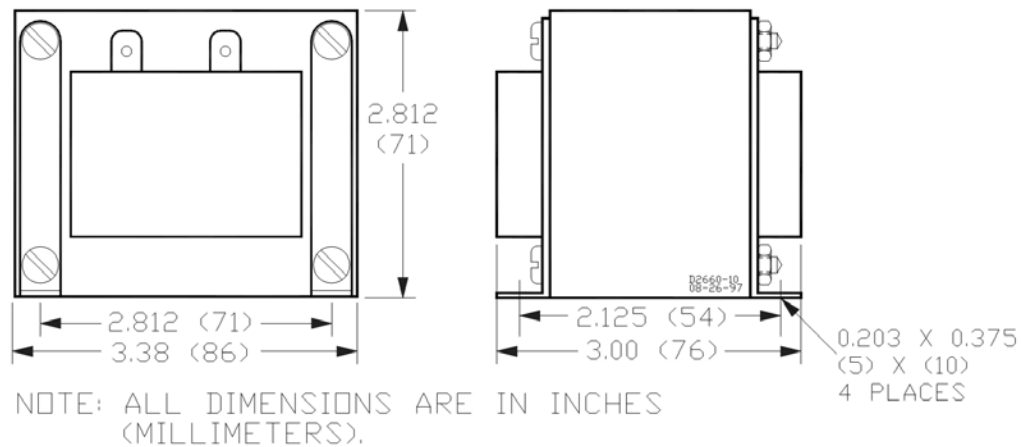

Figure 10. Outline Drawing, Isolation Transformer

Connections

Figures 11 through 15 illustrate the connections for various Reference Adjuster applications. Refer to the instruction manual for the device being controlled by the RA-70 for details on connecting the controlled device (e.g., SSE, MVC, etc.).

When connecting the RA-70, use the wire gauge specified by the controlled device instruction manual. To reduce electromagnetic interference, it may be necessary in some installations to mount the RA-70 remotely from the device being controlled. Twisted, shielded wire is recommended for interfacing these devices. Reference Adjusters with a 24 V, single-feed, power input (terminals 3 and 4) have the same polarity requirements as shown in Figures 11 through 15.

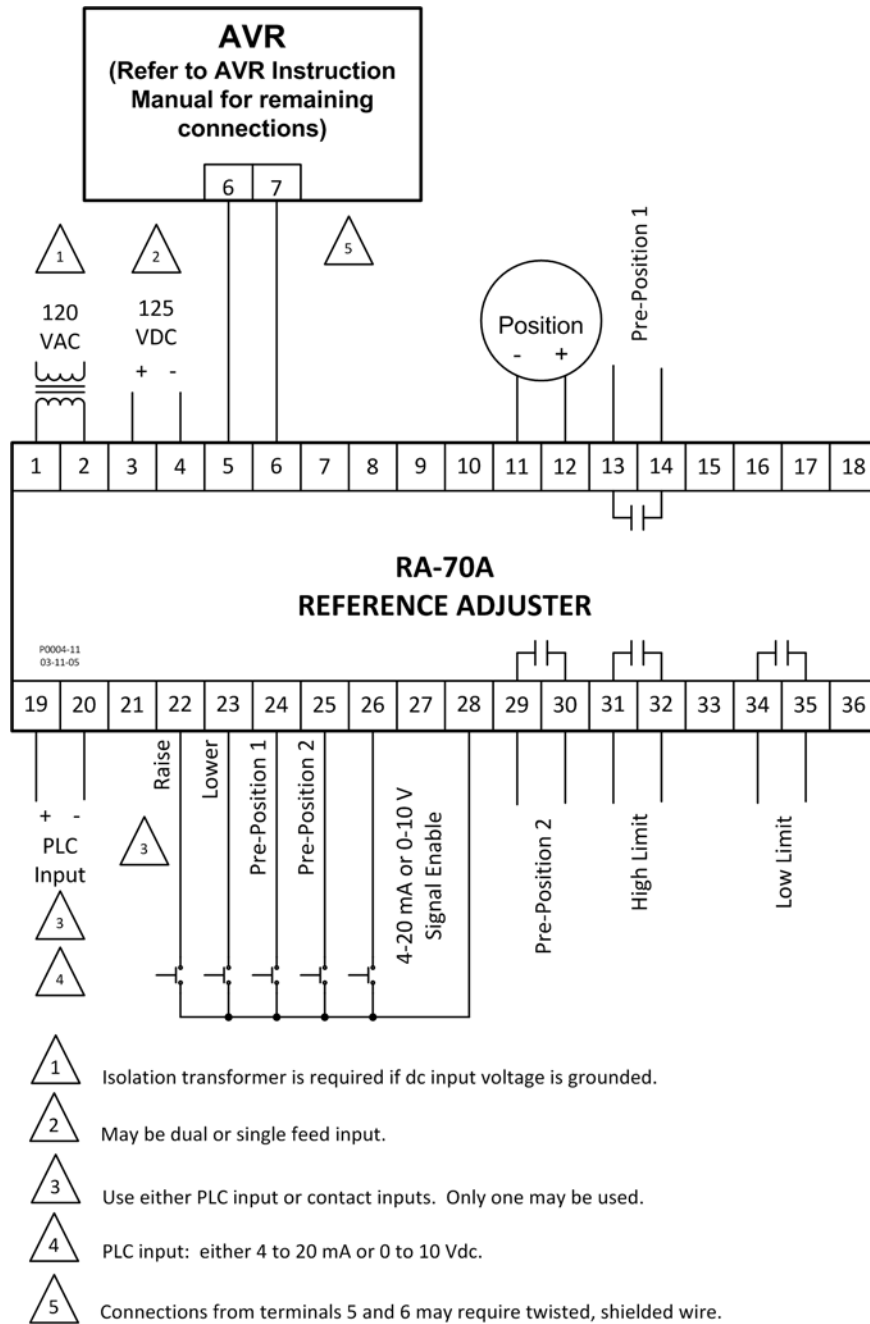

Figure 11. Typical RA-70 Connections with an AVR Interface or a Two-Wire Output

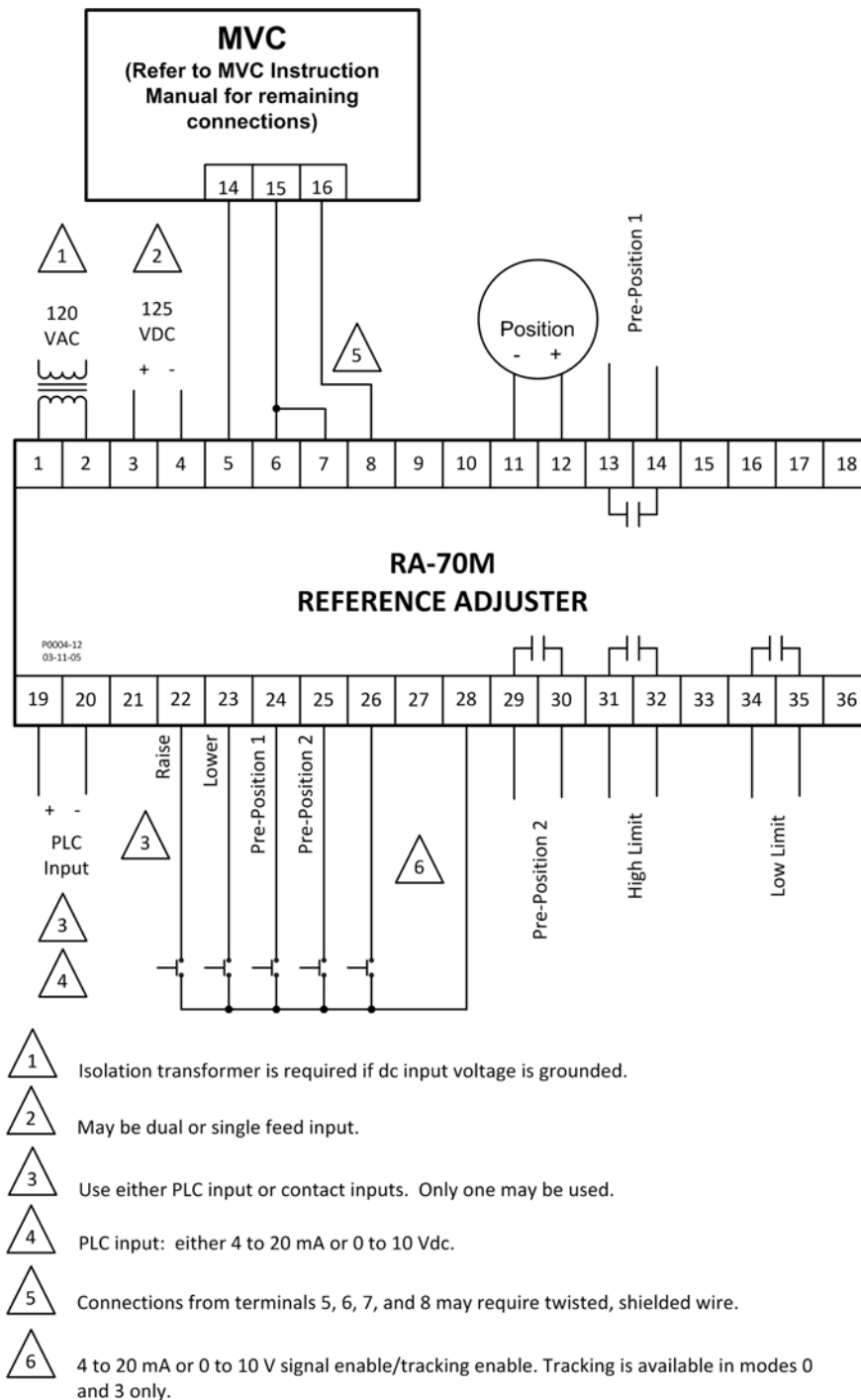

Figure 12. Typical RA-70 Connections with an MVC Interface

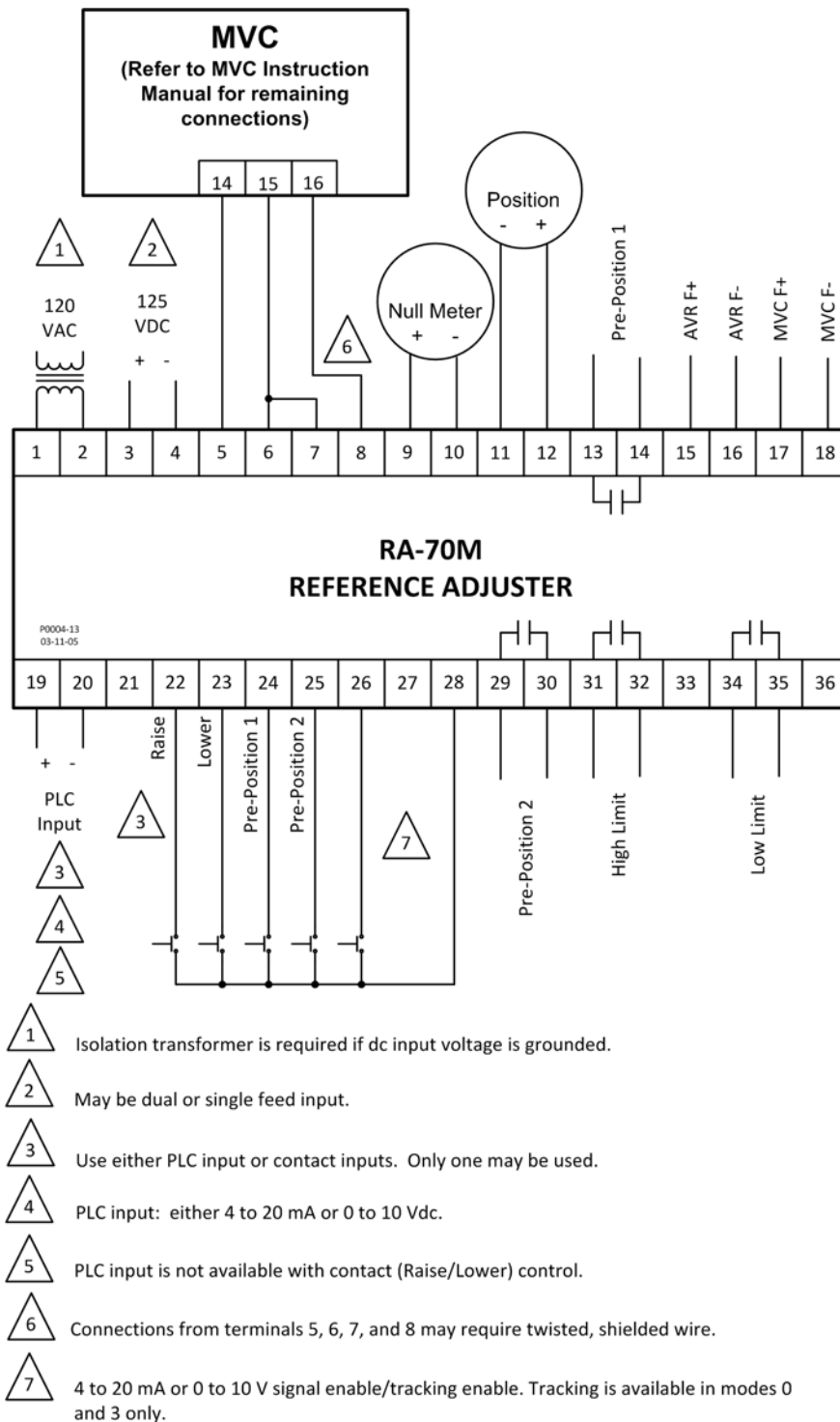
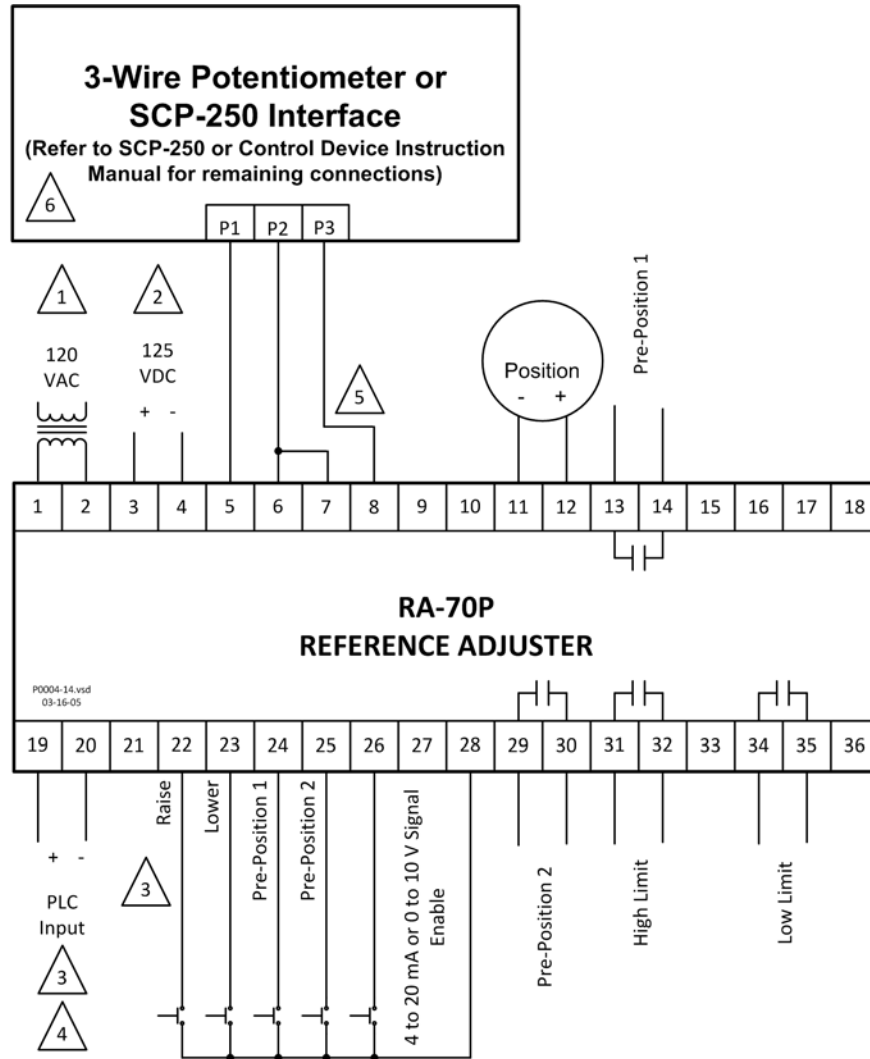
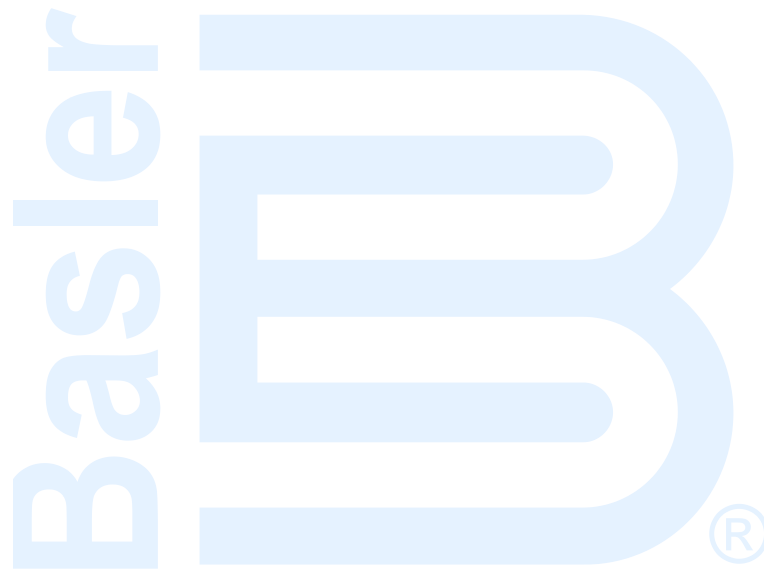

Figure 13. Typical RA-70 Connections with an MVC and a Null Signal



- 1 Isolation transformer is required if dc input voltage is grounded.
- 2 May be dual or single feed input.
- 3 Use either PLC input or contact inputs. Only one may be used.
- 4 PLC input: either 4 to 20 mA or 0 to 10 Vdc.
- 5 Connections from terminals 5, 6, 7, and 8 may require twisted, shielded wire.
- 6 For use with AVC63-12 or AVC125-10, connect regulator to terminals 7 and 8 of RA-70P to provide corresponding voltage setpoint control.

Figure 14. Typical RA-70 Connections with an SCP-250 or a Three-Wire Output



Operation

The Reference Adjuster operates like an adjustable resistor. With no power applied, the output terminals (TB1-5 and TB1-6) present the maximum internal resistance for all styles. Terminals TB1-7 and TB1-8 present the minimum resistance for styles RA-70M and RA-70P. Refer to Table 1. For the resistance values. When power is applied, the internal resistance will immediately go to the factory preset Pre-Position 1 (PREP 1) value. The following paragraphs describe how to operate the various features of the Reference Adjuster. Refer to Figure 16 for the location of the control switches and indicator LEDs. Please note that operation of the unit is the same, whether the front panel pushbutton switches are used or an external control contact is being used. In this discussion, only the pushbutton switches will be referenced as a contact closure will cause the same effect. The exception to this is the Program function, which permits only the front panel switch to be used.

Note

The Reference Adjuster has been preset at the factory. The text in the following paragraphs describes these settings. If settings other than those noted are desired, refer to the Calibration Procedures in the *Maintenance Instructions* chapters, depending on the serial number.

If the Reference Adjuster has been installed into an excitation system by Basler Electric, the factory presets may be different from those given in the following paragraphs. If settings other than those that have been preset are desired, refer to the Calibration Procedures in the *Maintenance Instructions* chapters, depending on the serial number.

Table 1. Maximum Output Resistance

Reference Adjuster Part Number	Maximum Resistance*	Type of Output
9 2522 00 101 and -104	5.0 k Ω	Potentiometer
9 2522 00 102 and -105	10.0 k Ω	Potentiometer
9 2522 00 107 and -108	2.5 k Ω	Potentiometer
9 2522 00 111 and -114	10.0 k Ω	Rheostat
9 2522 00 113 and -115	5.0 k Ω	Rheostat
9 2522 00 116, -117, -118, and -119	1.0 k Ω	Rheostat
9 2522 00 120, 121, 122, and -123	175 k Ω	Rheostat

* Values are shown with no operating power applied. Factory program settings may reflect lower maximum resistance once power is applied.

Raise/Lower Functions

The Reference Adjuster is preset at the factory for a high limit resistance of maximum resistance and a low limit resistance of minimum resistance. Refer to the style charts in the *Introduction* chapter for resistance values. To change these settings, refer to the *Calibration Instructions* in the *Maintenance Instructions* chapters, depending on the serial number.

The front panel RAISE and LOWER pushbutton switches will modify the output resistance. Pressing the RAISE pushbutton will cause the resistance to decrease for two-wire rheostat outputs and increase for three-wire potentiometer outputs. Conversely, pressing the LOWER pushbutton will cause the resistance to increase for two-wire rheostat outputs and decrease for three-wire potentiometer outputs. This is because when connected to a voltage regulator or other controlled device, a decrease in resistance will

cause an increase in device output and thus raise the generator output voltage. Therefore, the RAISE/LOWER terms refer to the generator output, not the output resistance of the Reference Adjuster. The RA-70 controls and indicators are shown in Figure 16.

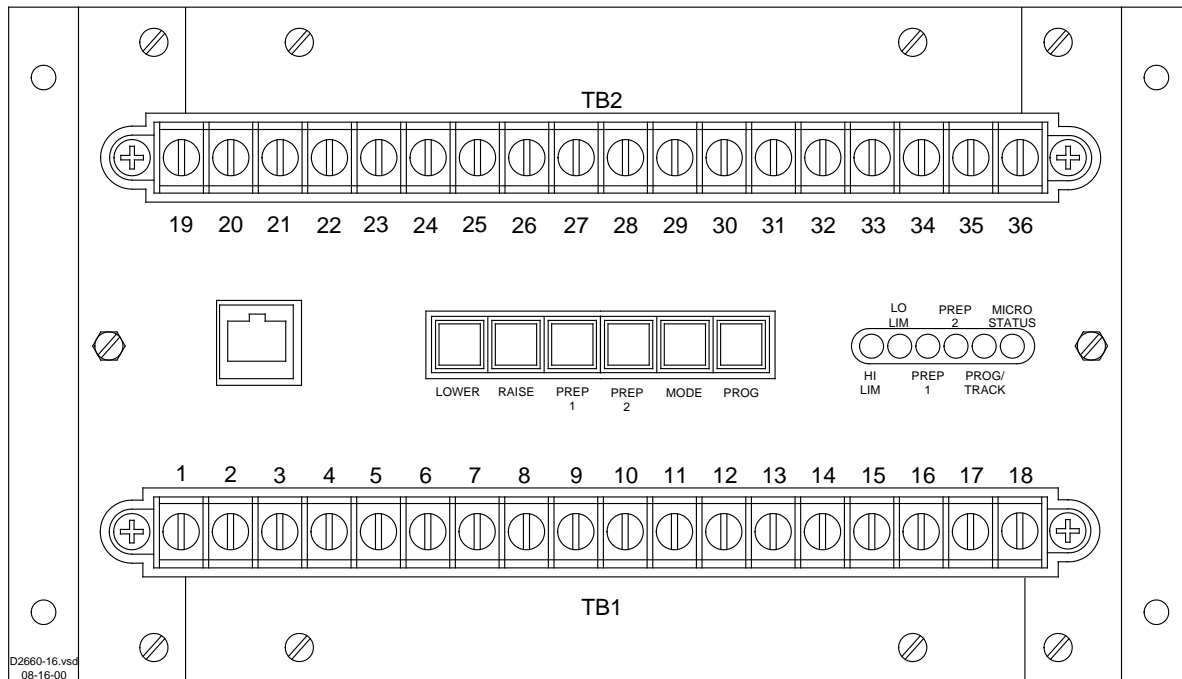

Figure 16. RA-70 Controls and Indicators

When either the RAISE or LOWER pushbutton is closed, the resistance will increment or decrement in one of the following ways: If the traverse mode is programmed as the factory default, after a short delay, the resistance will increment or decrement one step. If the button remains pressed for longer than two seconds, the resistance will increment or decrement at the pre-programmed rate. If the traverse mode is programmed for no delay before traversing, the resistance will immediately increment or decrement at the pre-programmed rate.

The traverse rate is a programmable speed that the Reference Adjuster will calculate based on the programmed high and low limits. One of six traverse rates (20, 40, 60, 80, 100, or 120 seconds) can be selected. The default rate is 80 seconds.

The Position Meter indicates the resistance location with respect to the total resistance between the High and Low Limits. An increment or decrement in resistance will be shown by a movement in the position meter.

Both the High and Low Limits have a front-panel LED indicator and a contact output (normally open). When the output resistance matches either the pre-programmed upper or lower value for these settings, the following occurs: the contacts close, the front-panel LED lights, and the Reference Adjuster is disabled from exceeding the attained limit.

Pre-Position 1 and 2 Functions

Refer to the *Maintenance Instructions* chapter for the factory presets and to change these settings.

There are two pre-position modes. Pressing either of the Pre-Position Switches (either PREP 1 or PREP 2) will cause the Reference Adjuster to immediately change its resistance to the pre-programmed value for the corresponding switch and mode.

Pre-Positions 1 and 2 are two independent setpoints that the user can program. Upon power-up of the Reference Adjuster, Pre-Position 1 is automatically selected, and that resistance will be presented as the output of the Reference Adjuster.

The Pre-Positions have two operating conditions:

1. In the Maintain (Hold) Mode, the Reference Adjuster goes to the setpoint and stays there, ignoring any other commands as long as the Pre-Position button (PREP 1 or PREP 2) is being pressed. Once the Pre-Position button is released, the Reference Adjuster will respond to them accordingly.
2. In the Release (Hold) Mode, the Reference Adjuster will go to the setpoint and then ignore Pre-Position button (PREP 1 or PREP 2) while it is being pressed. The Reference Adjuster will respond to Raise, Lower, and Tracking commands until the Pre-Position Button is released then pressed again. When this occurs, the Reference Adjuster will go to the setpoint and then ignore the Pre-Position button and respond to the Raise, Lower, and Tracking commands.

Each Pre-Position button (PREP 1 or PREP 2) can be independently programmed for either Maintain or Release Pre-Position.

Both of the Pre-Position settings have a front-panel LED indicator and a contact output (normally open). When the output resistance matches the pre-programmed value for the Mode switch being pressed, the contacts close and the front-panel LED lights.

The factory setting for the Pre-Positions are:

1. Pre-Position 1 is set to the Release Mode.
2. Pre-Position 2 is set to the Maintain Mode.

Mode Control Functions

There are five operating modes that can be programmed into the Reference Adjuster depending upon the style being used. Programming of each mode is controlled by the front panel MODE switch. The Reference Adjuster is factory preset for Mode 0. To change this default setting, refer to the Calibration Procedures in the *Maintenance Instructions* chapters (depending on the serial number).

Mode 0 (All Styles)

This mode is the factory default setting. It enables all raise/lower functions as commanded by either contact inputs or the front-panel pushbuttons.

Mode 0 (Model RA-70M Only)

In the RA-70M model only, this mode will enable the null signal output and/or the autotracking capability. The Reference Adjuster will monitor the outputs of both the automatic voltage regulator (AVR) and the manual voltage control (MVC) in order to provide a null signal to a null meter that will visually indicate the difference between the AVR and MVC outputs. If the autotracking feature is included, and enabled, the null meter will read zero after a programmed time delay to allow the Reference Adjuster to match the AVR and MVC outputs. When null is achieved, the front-panel PROG/TRACK indicator LED lights.

Note

All Mode 1 and Mode 2 RA-70s have a deadband of ± 1 step from the present setting. All of the stated steps are available, but a single step is not available.

For example:

The RA-70 is at a setting of X steps. A setting of X+1 steps is desired. Since a single step is not available, one method of producing a setting of X+1 steps would be to increase the setting by 3 steps followed by a decrease of 2 steps. This will yield the desired X+1 setting.

Mode 1 (0 - 10 V) (All Styles)

In this mode, a linear output is provided. When the front-panel MODE switch is pressed, the Reference Adjuster continuously samples the AUX inputs at TB1-19 and TB1-20. For every 39 mV change from 0 to 10 V, the output resistance is changed to the next resistance value. Since from 0 to 10 V there are 256 steps of 39 mV each for change, the total output resistance is divided by 256, thus each step is 0.68 Ω for a 175 Ω maximum output, 2 Ω for a 500 Ω maximum output, 4 Ω for a 1 k Ω maximum output, 4.9 Ω for a 1250 Ω maximum output, 9.7 Ω for a 2.5 k Ω maximum output, 19.5 Ω for a 5.0 k Ω maximum output, or 39 Ω for a 10 k Ω maximum output.

Note
Autotracking is not available in Mode 1.

Mode 2 (4 - 20 mA) (All Styles)

This mode is similar to Mode 1, except 0 to 20 mA is sensed across an internal resistor. The input current is divided into 256 steps; each step is 78 μ A. The output resistance responds to currents from 4 to 20 mA; the output resistance is divided into 204 steps. RA-70's with maximum resistance of 175 Ω have steps of 0.86 Ω , with maximum resistance of 500 Ω the steps are 2.4 Ω , with maximum resistance of 1,000 Ω the steps are 4.9 Ω , with maximum resistance of 1,250 Ω the steps are 6.1 Ω , with maximum resistance of 2,500 Ω the steps are 12.3 Ω , with maximum resistance of 5,000 Ω the steps are 24.5 Ω , with maximum resistance of 10,000 Ω the steps are 49 Ω .

Note
Autotracking is not available in Mode 2.

Mode 3 (SSE) (Model RA-70M Only)

This mode is exclusive to the RA-70M when used with the Basler Electric SSE family of exciter-regulators that require Autotracking of the Auto Mode by the manual volts control.

The Reference Adjuster monitors the AUX inputs at TB1-19 and TB1-20 which are connected to the SSE Control Chassis Error Signal Output Terminals. It then modifies its output resistance to bring the AUX input to 0 V.

By adjusting the Reference Adjuster's output resistance until this error signal equals zero (0) volts, the manual voltage adjustment to the SSE will track the Auto Volts output. When null is achieved, the Reference Adjuster front-panel TRACK indicator lights and remains lit as long as Auto and Manual remain nulled.

The Nullmeter outputs indicate how closely the SSE Manual Volts is tracking the SSE Auto Volts.

Mode 4 (0 - 10 V) (All Styles)

This Mode sets an input threshold on the AUX inputs. The output resistance is then ramped up or down based on the voltage input. The ramp speed is controlled by the voltage threshold command. The Raise and Lower fast speeds follow the programmed tracking speed. The Raise and Lower slow speeds are a percentage of the fast speed. Mode 4 allows the maximum resolution per step on the output resistance: 0.5 Ω , 0.68 Ω , 0.6 Ω , 1.2 Ω , or 2.4 Ω depending upon the model of Reference Adjuster being used. Table 2 shows how the different voltage inputs will modify the ramp speed of the resistance change.

Note
Autotracking is not available in Mode 4.

Table 2. AUX Input Voltage Level vs. Output Ram Speed

AUX Input Voltage Level	Output Resistance Ramp Speed
10.0 V to 8.0 V	Raise Fast
8.0 V to 6.0 V	Raise Slow
6.0 V to 4.0 V	Stop
4.0 V to 2.0 V	Lower Slow
2.0 V to 0.0 V	Lower Fast

Mode 5 (4 - 20 mA) (All Styles)

This Mode sets an input threshold on the AUX inputs. The output resistance is then ramped up or down based on the current input. The ramp speed is controlled by the current threshold commanded. The Raise and Lower fast speeds follow the programmed tracking speed. The Raise and Lower slow speeds are a percentage of the fast speed. Mode 5 allows the maximum resolution per step on the output resistance: 0.5 Ω , 0.68 Ω , 0.6 Ω , 1.2 Ω , or 2.4 Ω depending upon the model of Reference Adjuster being used. Table 3 shows how the different current inputs will modify the ramp speed of the resistance change.

Note

Autotracking is not available in Mode 5.

Table 3. AUX Input Voltage Level vs. Output Ramp Speed

AUX Input Voltage Level	Output Resistance Ramp Speed
20 to 17 mA	Raise Fast
17 to 14 mA	Raise Slow
14 to 10 mA	Stop
10 to 7 mA	Lower Slow
7 to 4 mA	Lower Fast
4 to 0 mA	Stop



Maintenance and Calibration for Units Prior to Serial Number 958

Preventive Maintenance

Periodic inspection of the reference adjuster should be made to ensure that it is kept clean and free from dirt and moisture. Also, it is highly recommended that all terminal connections be cleaned and tightened periodically.

Corrective Maintenance

Due to a protective, transparent conformal coating, repair of the printed circuit boards is difficult and should only be attempted by qualified personnel.

Warranty and Repair Service

The Basler Electric Reference Adjuster, Model RA-70, is warranted against defective material and workmanship for 18 months from the date of shipment from our factory. Units submitted for warranty repair should be returned to the factory in Highland, Illinois, freight pre-paid, with a complete written description of the reported problem. Pre-arrangement with either the nearest Basler Sales Office or the Factory will assure the fastest possible turnaround time.

Out-of-Warranty units should also be returned freight pre-paid, to the factory in Highland, Illinois. Repairs to out-of-warranty reference adjusters are made at a nominal charge, unless the unit is so extensively damaged that complete replacement is required.

Calibration

Unless the reference adjuster is delivered as part of a complete Basler Excitation System, the unit must be programmed if the factory settings are not desired. Refer to Table 4 for the factory settings.

Table 4. Factory Presets

Style Code	Resistance Value	Resistance		Pre-Position 1 and 2 Midpoint	Traverse Rate
		Minimum	Maximum		
1	500	0	500	250	80
2	175	0	175	87.5	80
3	5,000	0	5,000	2,500	80
4	1,000	0	1,000	500	80
5	1,250	0	1,250	833	80
6	2,500	0	2,500	1,250	80
7	10,000	0	10,000	2,500	80
8	5,000	0	5,000	2,500	80

NOTE: All units are preprogrammed for input Mode 0. The RA-70M has a factory preset Autotracking Response Delay of 3 seconds.

The reference adjuster can be programmed prior to start-up by resistance method or while the generator excitation system is operating. The procedure below outlines the method used while the generator excitation equipment is operating.

To program the reference adjuster in an installation, ensure that the generator excitation system is shut down, and then proceed to the following paragraphs.

Note

If required, the original factory preset default settings can be obtained after field calibration by disconnecting power and then re-applying input power while pressing the front panel **PROG** and **LOWER** pushbuttons.

Preliminary Instructions

1. Connect the reference adjuster per the appropriate interconnect given in the *Installation* chapter.
2. Apply input power.
3. Ensure that all external contacts connected to the reference adjuster are either opened or disconnected prior to programming.

High Limit Setpoint Programming

To program the High Limit, perform the following procedure:

1. To change the factory setting, press and release the following reference adjuster front-panel pushbutton switches in the order given: **PROG**, **RAISE**. Observe that the reference adjuster front-panel **PROG** LED blinks once slowly and that the reference adjuster front-panel **HI LIM** LED lights as shown below. (Note that the **MICRO STATUS** LED will remain lit.)

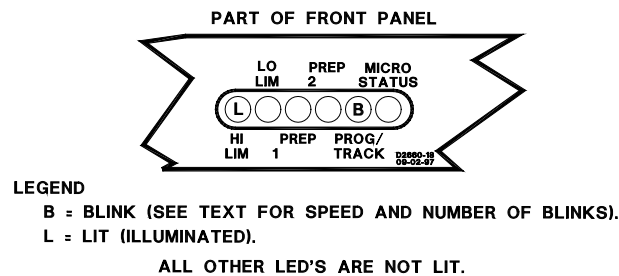

2. Monitor the generator output voltage and use the reference adjuster front-panel **RAISE** and **LOWER** pushbutton switches to set the generator output voltage to the desired high limit.
3. Press the reference adjuster front-panel **PROG** pushbutton switch twice to exit and save the program. To exit without saving the changed setting, press the reference adjuster front-panel **MODE** pushbutton switch once.

Low Limit Setpoint Programming

To program the Low Limit, perform the following procedure:

1. To change the factory setting, press and release the following reference adjuster front-panel pushbutton switches in the order given: **PROG**, **LOWER**. Observe that the reference adjuster front-panel **PROG** LED blinks once slowly and that the reference adjuster front-panel **LO LIM** LED lights as shown below. (Note that the **MICRO STATUS** LED will remain lit.)

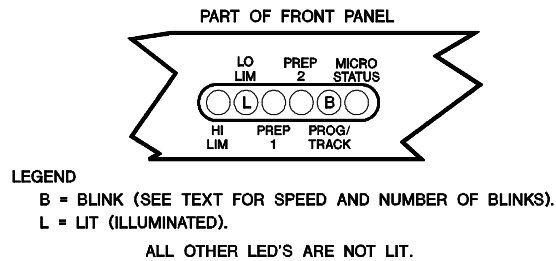

2. Monitor the output generator voltage and use the reference adjuster front-panel **RAISE** and **LOWER** pushbutton switches to set the generator output voltage to the desired low limit.
3. Press the reference adjuster front-panel **PROG** pushbutton switch twice to exit and save the program. To exit without saving the changed setting, press the reference adjuster front-panel **MODE** pushbutton switch once.

Pre-Position 1 Setpoint Programming

To program the Pre-Position 1 setting and its type, perform the following procedure:

1. To change the factory setting, press and release the following reference adjuster front-panel pushbutton switches in the order given: **PROG**, **PREP 1**. Observe that the reference adjuster front-panel **PROG** LED blinks once slowly and that the reference adjuster front panel **PREP 1** LED lights as shown below. (Note that the **MICRO STATUS** LED will remain lit.)

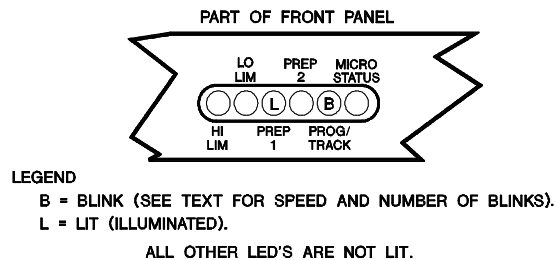

2. Monitor the generator output voltage and use the reference adjuster front-panel **RAISE** and **LOWER** pushbutton switches to set the generator output voltage to the desired pre-position 1 setting. If the adjustment to the setpoint was made prior to pressing the front-panel pushbutton switches **PROG**, **PREP 1**, press the **RAISE** and **LOWER** pushbutton switches once each. If this is not done, the reference adjuster will not recognize the change prior to the attempted programming.
3. Press the reference adjuster front-panel **PROG** pushbutton switch twice to exit and save the program. To exit without saving the changed setting, press the reference adjuster front-panel **MODE** pushbutton switch once.

Pre-Position 2 Setpoint Programming

To program the Pre-Position 2 setting and its type, perform the following procedure:

1. To change the factory setting, press and release the following front-panel pushbuttons in the order given: **PROG**, **PREP 2**. Observe that the reference adjuster front-panel **PROG** LED blinks once slowly and that the reference adjuster front-panel **PREP 2** LED lights as shown as shown below. (Note that the **MICRO STATUS** LED will remain lit.)

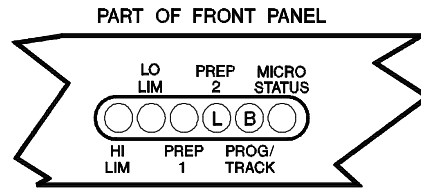
**LEGEND**

B = BLINK (SEE TEXT FOR SPEED AND NUMBER OF BLINKS).

L = LIT (ILLUMINATED).

ALL OTHER LED'S ARE NOT LIT.

2. Monitor the generator output voltage and use the reference adjuster front-panel **RAISE** and **LOWER** pushbutton switches to set the generator output voltage to the desired pre-position 2 setting. If the adjustment to the setpoint was made prior to pressing the front-panel push-button switches **PROG**, **PREP 1**, press the **RAISE** and **LOWER** pushbutton switches once each. If this is not done, the reference adjuster will not recognize the change prior to the attempted programming.
3. Press the reference adjuster front-panel **PROG** pushbutton switch twice to exit and save the program. To exit without saving the changed setting, press the reference adjuster front-panel **MODE** pushbutton switch once.

Pre-Position Type Programming

Refer to Table 4 for the factory preset settings. To select the Input Mode and calibrate the inputs, perform the following procedure:

Note

Factory calibrated settings: Pre-Position 1 = Release, Pre-Position 2 = Maintain.

1. To change the factory setting, press and release the reference adjuster front-panel pushbutton switches in the order given: **PROG**, **MODE**, and **PREP 1**. Observe that the reference adjuster front-panel **PROG** LED blinks three times quickly, and that the reference adjuster front-panel **PREP 1** LED lights as shown below. (Note that the **MICRO STATUS** LED will remain lit.)

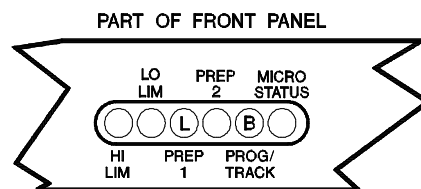
**LEGEND**

B = BLINK (SEE TEXT FOR SPEED AND NUMBER OF BLINKS).

L = LIT (ILLUMINATED).

ALL OTHER LED'S ARE NOT LIT.

2. Refer to Table 5 and the following illustration. Pressing the reference adjuster front-panel **RAISE** pushbutton switch will cause the reference adjuster front-panel **LO LIM** and **PREP 1** LEDs to illuminate in such a manner as to indicate the type of pre-position control that has been programmed into the unit. To change the factory setting, press the reference adjuster front-panel **RAISE** pushbutton switch until the LED pattern agrees with the pre-position command desired for the reference adjuster.
3. When the desired Pre-position type has been selected, press the reference adjuster front-panel **PROG** switch three times to save the setting.

Table 5. Pre-Position Program Release or Hold Binary LED Pattern

Pre-Position Type	LED Status	
	LO LIM LED	PREP 1 LED
Pre-position 1 – Hold Pre-position 2 – Hold	OFF	OFF
Pre-position 1 – Release Pre-position 2 – Hold	OFF	ON
Pre-position 1 – Hold Pre-position 2 – Release	ON	OFF
Pre-position 1 – Release Pre-position 2 – Release	ON	ON

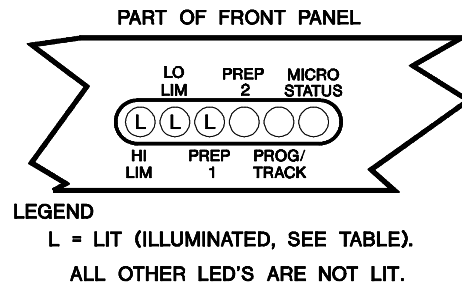

Autotracking Response Delay Programming

This procedure is applicable to the Reference Adjuster Model RA-70M only. Refer to Table 4 for the factory preset settings. The factory preset autotracking response delay is 3 seconds, to select a new response delay, perform the following procedure:

1. To change the factory setting, press and release the reference adjuster front-panel pushbutton switches in the order given: **PROG**, **MODE**, and **LOWER**. Observe that the reference adjuster front-panel **PROG** LED blinks twice quickly. (Note that the **MICRO STATUS** LED will remain lit.)

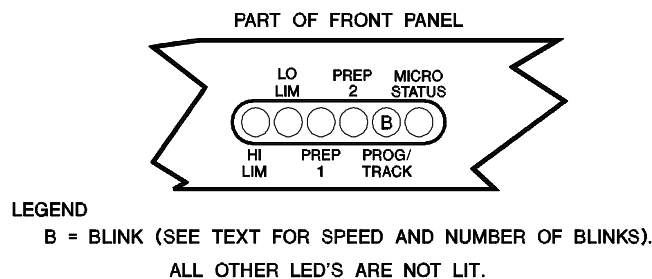

2. Refer to Table 6 and the following illustration. Pressing the reference adjuster front-panel **RAISE** pushbutton switch will cause the reference adjuster front-panel **HI LIM**, **LO LIM**, and **PREP 1** LEDs to light in such a manner as to indicate the response delay that has been programmed into the unit. To change the factory setting, press the reference adjuster front-panel **RAISE** pushbutton switch until the LED pattern agrees with the response delay desired for the reference adjuster.
3. When the desired response delay has been selected, press the reference adjuster front-panel **PROG** switch three times to save the setting.

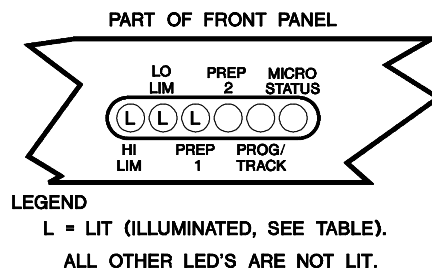

Table 6. Response Delay Binary LED Pattern

Response Delay in Seconds	LED Status		
	HI LIM LED	LO LIM LED	PREP 1 LED
0	OFF	OFF	OFF
1	OFF	OFF	ON
2	OFF	ON	OFF
3	OFF	ON	ON
4	ON	OFF	OFF
5	ON	OFF	ON
6	ON	ON	OFF
7	ON	ON	ON

Input Mode Programming

Refer to Table 4 for the factory preset settings. The factory preset mode is Mode 0, to select a new input mode, perform the following procedure:

1. To change the factory setting, press and release the reference adjuster front-panel pushbutton switches in the order given: **PROG**, **MODE**, and **MODE**. Observe that the reference adjuster front-panel **PROG** LED blinks four times quickly. (Note that the **MICRO STATUS** LED will remain lit.)

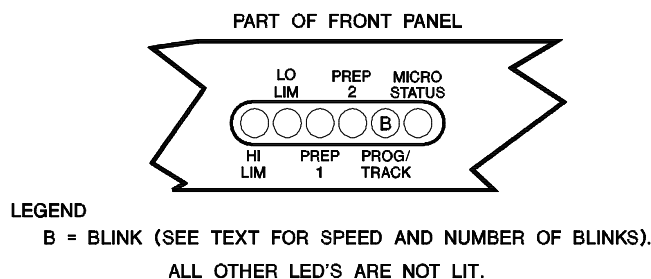

2. Refer to Table 7 and the following illustration. Pressing the reference adjuster front-panel **RAISE** pushbutton switch will cause the reference adjuster front-panel **HI LIM**, **LO LIM**, and **PREP 1** LEDs to light in such a manner as to indicate the input mode that has been programmed into the unit. To change the factory setting, press the reference adjuster front-panel **RAISE** pushbutton switch until the LED pattern agrees with the input mode desired for the reference adjuster.
3. When the desired input mode has been selected, press the reference adjuster front-panel **PROG** switch three times to save the setting.
4. In Mode 3 (RA-70M with a style of RA-70M___8, SSE only), if during tracking or null an offset exists, it can be zeroed out by using the following procedure:
 - a. Connect an input voltage or current (as required by input mode type) to the reference adjuster AUX terminals. Refer to the *Installation* chapter to ensure correct polarity.

- b. Adjust the Manual to null the AVR by pressing the front-panel **RAISE** or **LOWER** pushbutton switches.
- c. Press and release the following reference adjuster front-panel pushbutton switches: **PROG**, **MODE**, and **PREP 2**. Observe that the reference adjuster front-panel PROG LED blinks four times quickly.
- d. Press the reference adjuster front-panel **PROG** pushbutton switch three times. The input voltage/current as the reference adjuster AUX terminals is now the new "zero" point.

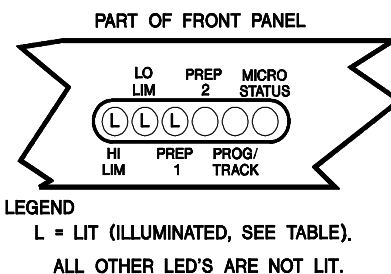

Table 7. Input Mode Binary LED Pattern

Input Mode Type	LED Status		
	HI LIM LED	LO LIM LED	PREP 1 LED
Mode 0 (Factory Preset)	OFF	OFF	OFF
Mode 1 (Linearized 0 to 10 Vdc Output)	OFF	OFF	ON
Mode 2 (Linearized 4 to 20 mA Output)	OFF	ON	OFF
Mode 3 (SSE Exclusive, RA-70M Only)	OFF	ON	ON
Mode 4 (0 to 10 Vdc Threshold Change)	ON	OFF	OFF
Mode 5 (4 to 20 mA Threshold Change)	ON	OFF	ON

5. In Mode 0 (RA-70M with a style of RA-70M___7 only), if the MVC/AVR inputs have an offset, they can be zeroed by using the following procedure:
 - a. Connect the MVC and AVR signals to the reference adjuster AUX terminals 15, 16, 17, and 18. Refer to the *Installation* chapter to ensure correct polarity.
 - b. Adjust the MVC to null the AVR by pressing the front-panel **RAISE** or **LOWER** pushbutton switches.
 - c. Press and release the following reference adjuster front-panel pushbutton switches: **PROG**, **MODE**, and **PREP 2**. Observe that the reference adjuster front-panel PROG LED blinks four times quickly.
 - d. Press the reference adjuster front-panel **PROG** pushbutton switch three times. The MVC input will now have the necessary offset for proper tracking.

Traverse Rate Programming

Refer to Table 4 for the factory preset settings. The factory preset traverse rate is 80 seconds, to select a new traverse rate, perform the following procedure. (Note that the **MICRO STATUS** LED will always remain illuminated.)

1. To change the factory setting, press and release the reference adjuster front-panel pushbutton switches in the order given: **PROG**, **MODE**, and **RAISE**. Observe that the reference adjuster front-panel **PROG** LED blinks once quickly.

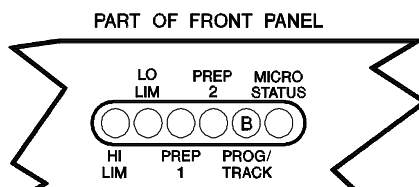

LEGEND

B = BLINK (SEE TEXT FOR SPEED AND NUMBER OF BLINKS).

ALL OTHER LED'S ARE NOT LIT.

2. Refer to Table 8 and the accompanying illustration. Pressing the reference adjuster front-panel **RAISE** pushbutton switch will cause the reference adjuster front-panel **HI LIM**, **LO LIM**, and **PREP 1** LEDs to illuminate in such a manner as to indicate the traverse rate that has been programmed into the unit. To change the factory setting, press the reference adjuster front-panel **RAISE** pushbutton switch until the LED pattern agrees with the traverse rate desired for the reference adjuster.

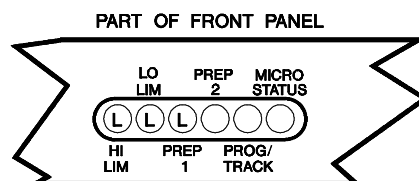

LEGEND

L = LIT (ILLUMINATED, SEE TABLE).

ALL OTHER LED'S ARE NOT LIT.

Table 8. Traverse Rate Binary LED Pattern

Traverse Rate in Seconds	LED Status		
	HI LIM LED	LO LIM LED	PREP 1 LED
20	OFF	ON	OFF
40	OFF	ON	ON
60	ON	OFF	OFF
80	ON	OFF	ON
100	ON	ON	OFF
120	ON	ON	ON

3. When the desired traverse rate has been selected, press the reference adjuster front-panel **PROG** switch four times to save the setting.

Calibration - Quick Reference

Tables 8 through 13 provide a quick reference to the calibration of the reference adjuster. It is by no means intended to replace the above paragraphs but is, instead, intended to provide a reference for the experienced operator/maintenance technician when verifying and calibrating the reference adjuster.

Table 9. Programming Quick Reference

To Program:	Pressing Order:	To Adjust, Use:	PROG/TRACK LED
High Limit	PROG RAISE	RAISE/LOWER	1 long blink
Low Limit	PROG LOWER	RAISE/LOWER	1 long blink
Pre-Position 1	PROG PREP 1	RAISE/LOWER	1 long blink
Pre-Position 2	PROG PREP 2	RAISE/LOWER	1 long blink
Traverse Rate	PROG MODE RAISE	RAISE	1 short blink
Auto Tracking Response Delay	PROG MODE LOWER	RAISE	2 short blinks
Pre-Position 1, 2 Type	PROG MODE PREP 1	RAISE	3 short blinks
Input Mode	PROG MODE MODE	RAISE	4 short blinks
Offset Calibration (Null/Tracking)	PROG MODE PREP 2	RAISE	5 short blinks

Table 10. Traverse Rate Quick Reference

Traverse Rate (seconds)	LED Status		
	HI LIM LED	LO LIM LED	PREP 1 LED
20	OFF	ON	OFF
40	OFF	ON	ON
60	ON	OFF	OFF
80	ON	OFF	ON
100	ON	ON	OFF
120	ON	ON	ON

Table 11. Response Delay Quick Reference

Response Delay (seconds)	LED Status		
	HI LIM LED	LO LIM LED	PREP 1 LED
0	OFF	OFF	OFF
1	OFF	OFF	ON
2	OFF	ON	OFF
3	OFF	ON	ON
4	ON	OFF	OFF
5	ON	OFF	ON
6	ON	ON	OFF
7	ON	ON	ON

Table 12. Pre-Position Type Quick Reference

Pre-position Type	LED Status	
	LO LIM LED	PREP 1 LED
Pre-position 1 - Hold Pre-position 2 - Hold	OFF	OFF
Pre-position 1 - Release Pre-position 2 - Hold	OFF	ON
Pre-position 1 - Hold Pre-position 2 - Release	ON	OFF
Pre-position 1 - Release Pre-position 2 - Release	ON	ON

Table 13. Input Modes Quick Reference

Input Mode Type	LED Status		
	HI LIM LED	LO LIM LED	PREP 1 LED
Mode 0 (Factory Preset)	OFF	OFF	OFF
Mode 1 (Linearized 0-10 Vdc Output)	OFF	OFF	ON
Mode 2 (Linearized 4-20 mA Output)	OFF	ON	OFF
Mode 3 (SSE Exclusive, RA-70M only)	OFF	ON	ON
Mode 4 (0-10 Vdc Threshold Change)	ON	OFF	OFF
Mode 5 (4-20 mA Threshold Change)	ON	OFF	ON

Maintenance and Calibration for Units after Serial Number 958

Preventive Maintenance

Periodic inspection of the reference adjuster should be made to ensure that it is kept clean and free from dirt and moisture. Also, it is highly recommended that all terminal connections be cleaned and tightened periodically.

Corrective Maintenance

Due to a protective, transparent conformal coating, repair of the printed circuit boards is difficult and should only be attempted by qualified personnel.

Warranty and Repair Service

The Basler Electric Reference Adjuster, Model RA-70, is warranted against defective material and workmanship for 18 months from the date of shipment from our factory. Units submitted for warranty repair should be returned to the factory in Highland, Illinois, freight pre-paid, with a complete written description of the reported problem. Pre-arrangement with either the nearest Basler Sales Office or the Factory will assure the fastest possible turnaround time.

Out-of-Warranty units should also be returned freight pre-paid, to the factory in Highland, Illinois. Repairs to out-of-warranty reference adjusters are made at a nominal charge, unless the unit is so extensively damaged that complete replacement is required.

Calibration

Unless the reference adjuster is delivered as part of a complete Basler Excitation System, the unit must be programmed if the factory settings are not desired. Refer to Table 14 for the factory settings.

Table 14. Factory Presets

Style Code	Ohmic Value	Resistance		Pre-Position 1 & 2		Traverse Rate
		Minimum	Maximum	Midrange A & P Type	Minimum M Type	
1	500	0	500	250	N/A	80
2	175	0	175	87.5	N/A	80
3	5,000	0	5,000	2,500	0	80
4	1,000	0	1,000	500	N/A	80
5	1,250	0	1,250	625	0	80
6	2,500	0	2,500	1,250	0	80
7	10,000	0	10,000	2,500	0	80
8	5,000	0	5,000	2,500	0	80

NOTE: All units are preprogrammed for input Mode 0. The RA-70M has a factory preset Autotracking Response Delay of 3 seconds. All units have a pre-programmed 2-second delay before traversing.

The reference adjuster can be programmed prior to start-up by resistance method or while the generator excitation system is operating. The procedure below outlines the method used while the generator excitation equipment is operating.

To program the reference adjuster in an installation, ensure that the generator excitation system is shut down, and then proceed to the following paragraphs.

Note

If required, the original factory preset default settings can be obtained after field calibration by disconnecting power and then re-applying input power while pressing the front panel **PROG** and **LOWER** pushbuttons.

Preliminary Instructions

1. Connect the reference adjuster per the appropriate interconnect given in the *Installation* chapter.
2. Apply input power.
3. Ensure that all external contacts connected to the reference adjuster are either opened or disconnected prior to programming.

High Limit Setpoint Programming

To program the High Limit, perform the following procedure:

1. To change the factory setting, press and release the following reference adjuster front-panel pushbutton switches in the order given: **PROG**, **RAISE**. Observe that the reference adjuster front-panel **PROG** LED blinks once slowly and that the reference adjuster front-panel **HI LIM** LED lights as shown below. (Note that the **MICRO STATUS** LED will remain lit.)

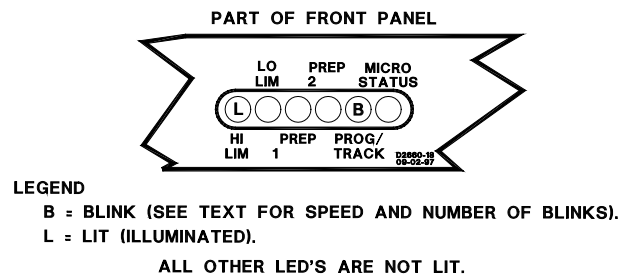

2. Monitor the generator output voltage and use the reference adjuster front-panel **RAISE** and **LOWER** pushbutton switches to set the generator output voltage to the desired high limit.
3. Press the reference adjuster front-panel **PROG** pushbutton switch twice to exit and save the program. To exit without saving the changed setting, press the reference adjuster front-panel **MODE** pushbutton switch once.

Low Limit Setpoint Programming

To program the Low Limit, perform the following procedure:

1. To change the factory setting, press and release the following reference adjuster front-panel pushbutton switches in the order given: **PROG**, **LOWER**. Observe that the reference adjuster front-panel **PROG** LED blinks once slowly and that the reference adjuster front-panel **LO LIM** LED lights as shown below. (Note that the **MICRO STATUS** LED will remain lit.)

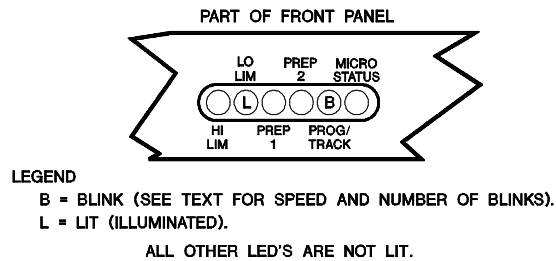

2. Monitor the output generator voltage and use the reference adjuster front-panel **RAISE** and **LOWER** pushbutton switches to set the generator output voltage to the desired low limit.
3. Press the reference adjuster front-panel **PROG** pushbutton switch twice to exit and save the program. To exit without saving the changed setting, press the reference adjuster front-panel **MODE** pushbutton switch once.

Pre-Position 1 Setpoint Programming

To program the Pre-Position 1 setting and its type, perform the following procedure:

1. To change the factory setting, press and release the following reference adjuster front-panel pushbutton switches in the order given: **PROG**, **PREP 1**. Observe that the reference adjuster front-panel **PROG** LED blinks once slowly and that the reference adjuster front panel **PREP 1** LED lights as shown below. (Note that the **MICRO STATUS** LED will remain lit.)

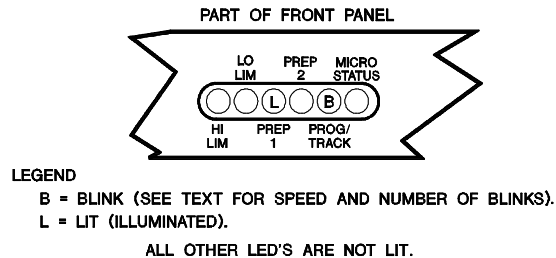

2. Monitor the generator output voltage and use the reference adjuster front-panel **RAISE** and **LOWER** pushbutton switches to set the generator output voltage to the desired pre-position 1 setting. If the adjustment to the setpoint was made prior to pressing the front-panel pushbutton switches **PROG**, **PREP 1**, press the **RAISE** and **LOWER** pushbutton switches once each. If this is not done, the reference adjuster will not recognize the change prior to the attempted programming.
3. Press the reference adjuster front-panel **PROG** pushbutton switch twice to exit and save the program. To exit without saving the changed setting, press the reference adjuster front-panel **MODE** pushbutton switch once.

Pre-Position 2 Setpoint Programming

To program the Pre-Position 2 setting and its type, perform the following procedure:

1. To change the factory setting, press and release the following front-panel pushbuttons in the order given: **PROG**, **PREP 2**. Observe that the reference adjuster front-panel **PROG** LED blinks once slowly and that the reference adjuster front-panel **PREP 2** LED lights as shown as shown below. (Note that the **MICRO STATUS** LED will remain lit.)

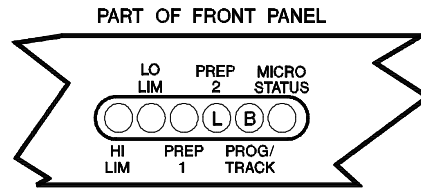
**LEGEND**

B = BLINK (SEE TEXT FOR SPEED AND NUMBER OF BLINKS).

L = LIT (ILLUMINATED).

ALL OTHER LED'S ARE NOT LIT.

2. Monitor the generator output voltage and use the reference adjuster front-panel **RAISE** and **LOWER** pushbutton switches to set the generator output voltage to the desired pre-position 2 setting. If the adjustment to the setpoint was made prior to pressing the front-panel push-button switches **PROG**, **PREP 1**, press the **RAISE** and **LOWER** pushbutton switches once each. If this is not done, the reference adjuster will not recognize the change prior to the attempted programming.
3. Press the reference adjuster front-panel **PROG** pushbutton switch twice to exit and save the program. To exit without saving the changed setting, press the reference adjuster front-panel **MODE** pushbutton switch once.

Pre-Position Type Programming

Refer to Table 14 for the factory preset settings. To select the Input Mode and calibrate the inputs, perform the following procedure:

Note

Factory calibrated settings: Pre-Position 1 = Release, Pre-Position 2 = Maintain.

1. To change the factory setting, press and release the reference adjuster front-panel pushbutton switches in the order given: **PROG**, **MODE**, and **PREP 1**. Observe that the reference adjuster front-panel **PROG** LED blinks two times quickly, and that the reference adjuster front-panel **PREP 1** LED lights as shown below. (Note that the **MICRO STATUS** LED will remain lit.)

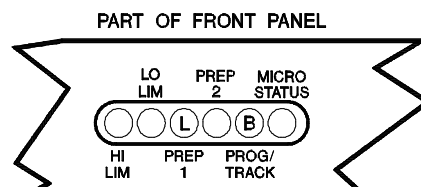
**LEGEND**

B = BLINK (SEE TEXT FOR SPEED AND NUMBER OF BLINKS).

L = LIT (ILLUMINATED).

ALL OTHER LED'S ARE NOT LIT.

2. Refer to Table 15 and the following illustration. Pressing the reference adjuster front-panel **RAISE** pushbutton switch will cause the reference adjuster front-panel **LO LIM** and **PREP 1** LEDs to illuminate in such a manner as to indicate the type of pre-position control that has been programmed into the unit. To change the factory setting, press the reference adjuster front-panel **RAISE** pushbutton switch until the LED pattern agrees with the pre-position command desired for the reference adjuster.
3. When the desired Pre-position type has been selected, press the reference adjuster front-panel **PROG** switch three times to save the setting.

Table 15. Pre-Position Program Release or Hold Binary LED Pattern

Pre-Position Type	LED Status	
	LO LIM LED	PREP 1 LED
Pre-position 1 – Hold Pre-position 2 – Hold	OFF	OFF
Pre-position 1 – Release Pre-position 2 – Hold	OFF	ON
Pre-position 1 – Hold Pre-position 2 – Release	ON	OFF
Pre-position 1 – Release Pre-position 2 – Release	ON	ON

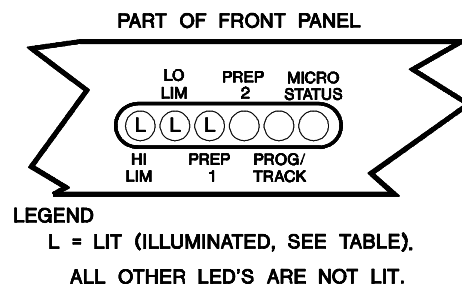

Autotracking Response Delay Programming

This procedure is applicable to the Reference Adjuster Model RA-70M only. Refer to Table 14 for the factory preset settings. The factory preset autotracking response delay is 3 seconds, to select a new response delay, perform the following procedure:

1. To change the factory setting, press and release the reference adjuster front-panel pushbutton switches in the order given: **PROG**, **MODE**, and **LOWER**. Observe that the reference adjuster front-panel **PROG** LED blinks once quickly. (Note that the **MICRO STATUS** LED will remain lit.)

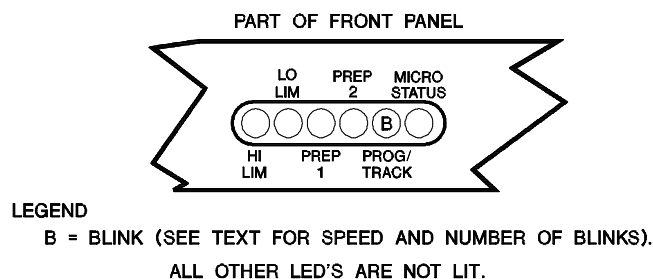

2. Refer to Table 16 and the following illustration. Pressing the reference adjuster front-panel **RAISE** pushbutton switch will cause the reference adjuster front-panel **HI LIM**, **LO LIM**, and **PREP 1** LEDs to light in such a manner as to indicate the response delay that has been programmed into the unit. To change the factory setting, press the reference adjuster front-panel **RAISE** pushbutton switch until the LED pattern agrees with the response delay desired for the reference adjuster.
3. When the desired response delay has been selected, press the reference adjuster front-panel **PROG** switch three times to save the setting.

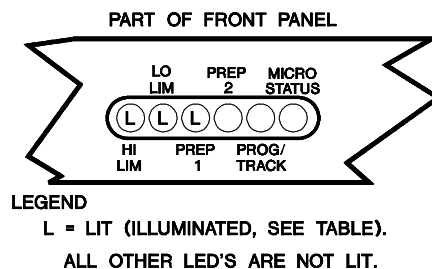

Table 16. Response Delay Binary LED Pattern

Response Delay in Seconds	LED Status		
	HI LIM LED	LO LIM LED	PREP 1 LED
0	OFF	OFF	OFF
1	OFF	OFF	ON
2	OFF	ON	OFF
3	OFF	ON	ON
4	ON	OFF	OFF
5	ON	OFF	ON
6	ON	ON	OFF
7	ON	ON	ON

Input Mode Programming

Refer to Table 14 for the factory preset settings. The factory preset mode is Mode 0, to select a new input mode, perform the following procedure:

- To change the factory setting, press and release the reference adjuster front-panel pushbutton switches in the order given: **PROG**, **MODE**, and **MODE**. Observe that the reference adjuster front-panel **PROG** LED blinks three times quickly. (Note that the **MICRO STATUS** LED will remain lit.)

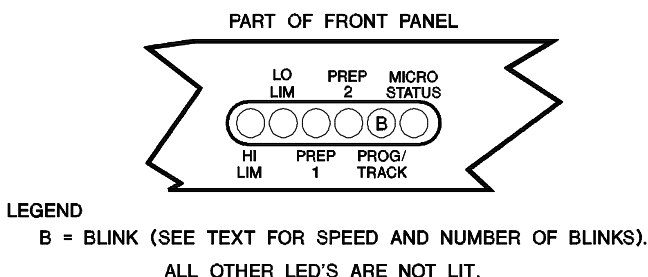

- Refer to Table 17 and the following illustration. Pressing the reference adjuster front-panel **RAISE** pushbutton switch will cause the reference adjuster front-panel **HI LIM**, **LO LIM**, and **PREP 1** LEDs to light in such a manner as to indicate the input mode that has been programmed into the unit. To change the factory setting, press the reference adjuster front-panel **RAISE** pushbutton switch until the LED pattern agrees with the input mode desired for the reference adjuster.
- When the desired input mode has been selected, press the reference adjuster front-panel **PROG** switch three times to save the setting.
- In Mode 3 (RA-70M with a style of RA-70M___8, SSE only), if during tracking or null an offset exists, it can be zeroed out by using the following procedure:
 - Connect an input voltage or current (as required by input mode type) to the reference adjuster AUX terminals. Refer to the *Installation* chapter to ensure correct polarity.

- b. Adjust the Manual to null the AVR by pressing the front-panel **RAISE** or **LOWER** pushbutton switches.
- c. Press and release the following reference adjuster front-panel pushbutton switches: **PROG**, **MODE**, and **PREP 2**. Observe that the reference adjuster front-panel PROG LED blinks four times quickly.
- d. Press the reference adjuster front-panel **PROG** pushbutton switch three times. The input voltage/current as the reference adjuster AUX terminals is now the new "zero" point.

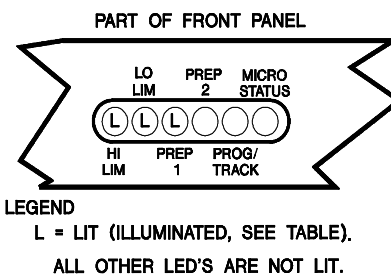

Table 17. Input Mode Binary LED Pattern

Input Mode Type	LED Status		
	HI LIM LED	LO LIM LED	PREP 1 LED
Mode 0 (Factory Preset)	OFF	OFF	OFF
Mode 1 (Linearized 0 to 10 Vdc Output)	OFF	OFF	ON
Mode 2 (Linearized 4 to 20 mA Output)	OFF	ON	OFF
Mode 3 (SSE Exclusive, RA-70M Only)	OFF	ON	ON
Mode 4 (0 to 10 Vdc Threshold Change)	ON	OFF	OFF
Mode 5 (4 to 20 mA Threshold Change)	ON	OFF	ON

5. In Mode 0 (RA-70M with a style of RA-70M___7 only), if the MVC/AVR inputs have an offset, they can be zeroed by using the following procedure:
 - a. Connect the MVC and AVR signals to the reference adjuster AUX terminals 15, 16, 17, and 18. Refer to the *Installation* chapter to ensure correct polarity.
 - b. Adjust the MVC to null the AVR by pressing the front-panel **RAISE** or **LOWER** pushbutton switches.
 - c. Press and release the following reference adjuster front-panel pushbutton switches: **PROG**, **MODE**, and **PREP 2**. Observe that the reference adjuster front-panel PROG LED blinks four times quickly.
 - d. Press the reference adjuster front-panel **PROG** pushbutton switch three times. The MVC input will now have the necessary offset for proper tracking.

Traverse Rate Programming

Refer to Table 14 for the factory preset settings. The factory preset traverse rate is 80 seconds, to select a new traverse rate, perform the following procedure. (Note that the **MICRO STATUS** LED will always remain illuminated.)

- To change the factory setting, press and release the reference adjuster front-panel pushbutton switches in the order given: **PROG**, **MODE**, **RAISE**, and **PREP 1**. Observe that the reference adjuster front-panel **PROG** LED blinks five times quickly.

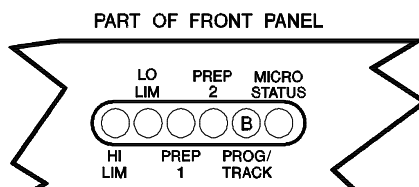

LEGEND

B = BLINK (SEE TEXT FOR SPEED AND NUMBER OF BLINKS).

ALL OTHER LED'S ARE NOT LIT.

- Refer to Table 18 and the accompanying illustration. Pressing the reference adjuster front-panel **RAISE** pushbutton switch will cause the reference adjuster front-panel **HI LIM**, **LO LIM**, and **PREP 1** LEDs to illuminate in such a manner as to indicate the traverse rate that has been programmed into the unit. To change the factory setting, press the reference adjuster front-panel **RAISE** pushbutton switch until the LED pattern agrees with the traverse rate desired for the reference adjuster.

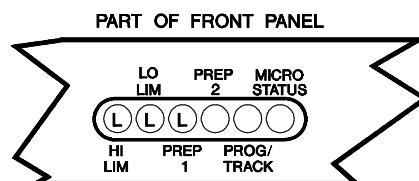

LEGEND

L = LIT (ILLUMINATED, SEE TABLE).

ALL OTHER LED'S ARE NOT LIT.

Table 18. Traverse Rate Binary LED Pattern

Traverse Rate in Seconds	LED Status		
	HI LIM LED	LO LIM LED	PREP 1 LED
20	OFF	ON	OFF
40	OFF	ON	ON
60	ON	OFF	OFF
80	ON	OFF	ON
100	ON	ON	OFF
120	ON	ON	ON

- When the desired traverse rate has been selected, press the reference adjuster front-panel **PROG** switch four times to save the setting.

Traverse Mode Programming

Refer to Table 14 for the factory preset settings. The Traverse Mode is factory preset such that there is a 2-second delay before entering the traverse rate. To select the Traverse Mode in which there is no delay, perform the following procedure. (Note that the front panel **MICRO STATUS** LED will always remain illuminated.)

- To change the factory setting, press and release the following front-panel pushbuttons in the order given: **PROG**, **MODE**, **RAISE**, and **PREP 2**. Observe that the reference adjuster front-panel **PROG** LED blinks six times quickly.

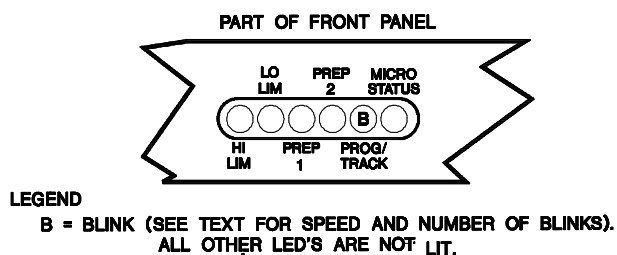

2. Refer to Table 24 and the following illustration. Pressing the reference adjuster front-panel **RAISE** pushbutton switch will cause the reference adjuster front-panel **PREP 1** LED to light in such a manner as to indicate the Traverse Mode that has been programmed into the unit. To change the factory setting, press the reference adjuster front-panel **RAISE** pushbutton switch until the LED pattern agrees with the Traverse Mode desired for the reference adjuster.

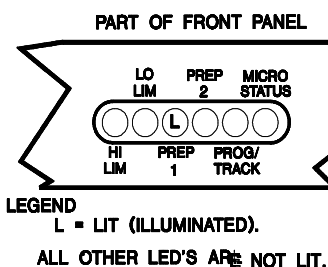

Table 19. Traverse Mode Binary LED Pattern

Traverse Mode	LED Status
	PREP 1 LED
Delayed	OFF
No Delay	ON

3. When the desired Traverse Mode has been selected, press the reference adjuster front-panel **PROG** switch four times to save the setting.

Calibration - Quick Reference

Tables 18 through 24 provide a quick reference to the calibration of the reference adjuster. It is by no means intended to replace the above paragraphs but is, instead, intended to provide a reference for the experienced operator/maintenance technician when verifying and calibrating the reference adjuster.

Table 20. Programming Quick Reference

To Program:	Pressing Order:	To Adjust, Use:	PROG/TRACK LED
High Limit	PROG RAISE	RAISE/LOWER	1 long blink
Low Limit	PROG LOWER	RAISE/LOWER	1 long blink
Pre-Position 1	PROG PREP 1	RAISE/LOWER	1 long blink
Pre-Position 2	PROG PREP 2	RAISE/LOWER	1 long blink

To Program:	Pressing Order:	To Adjust, Use:	PROG/TRACK LED
Auto Tracking Response Delay	PROG MODE LOWER	RAISE	1 short blinks
Pre-Position 1, 2 Type	PROG MODE PREP 1	RAISE	2 short blinks
Input Mode	PROG MODE MODE	RAISE	3 short blinks
Offset Calibration (Null/Tracking)	PROG MODE PREP 2	RAISE	4 short blinks
Traverse Rate	PROG MODE RAISE PREP 1	RAISE	5 short blinks
Traverse Mode	PROG MODE RAISE PREP 2	RAISE	6 short blinks

Table 21. Traverse Rate Quick Reference

Traverse Rate (seconds)	LED Status		
	HI LIM LED	LO LIM LED	PREP 1 LED
20	OFF	ON	OFF
40	OFF	ON	ON
60	ON	OFF	OFF
80	ON	OFF	ON
100	ON	ON	OFF
120	ON	ON	ON

Table 22. Response Delay Quick Reference

Response Delay (seconds)	LED Status		
	HI LIM LED	LO LIM LED	PREP 1 LED
0	OFF	OFF	OFF
1	OFF	OFF	ON
2	OFF	ON	OFF
3	OFF	ON	ON
4	ON	OFF	OFF
5	ON	OFF	ON
6	ON	ON	OFF
7	ON	ON	ON

Table 23. Pre-Position Type Quick Reference

Pre-position Type	LED Status	
	LO LIM LED	PREP 1 LED
Pre-position 1 - Hold Pre-position 2 - Hold	OFF	OFF
Pre-position 1 - Release Pre-position 2 - Hold	OFF	ON
Pre-position 1 - Hold Pre-position 2 - Release	ON	OFF
Pre-position 1 - Release Pre-position 2 - Release	ON	ON

Table 24. Input Modes Quick Reference

Input Mode Type	LED Status		
	HI LIM LED	LO LIM LED	PREP 1 LED
Mode 0 (Factory Preset)	OFF	OFF	OFF
Mode 1 (Linearized 0-10 Vdc Output)	OFF	OFF	ON
Mode 2 (Linearized 4-20 mA Output)	OFF	ON	OFF
Mode 3 (SSE Exclusive, RA-70M only)	OFF	ON	ON
Mode 4 (0-10 Vdc Threshold Change)	ON	OFF	OFF
Mode 5 (4-20 mA Threshold Change)	ON	OFF	ON

Table 25. Traverse Mode Quick Reference

Traverse Mode	PREP 1 LED Status
Delayed	OFF
No Delay	ON

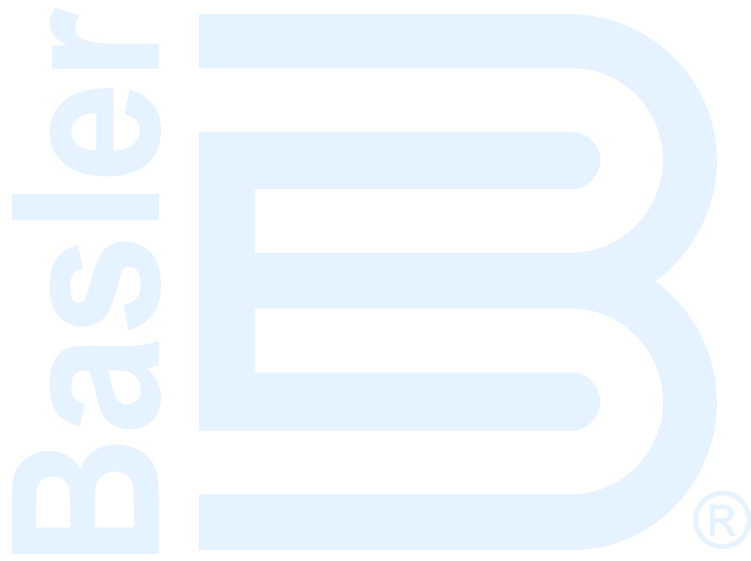

Specifications

RA-70 Reference Adjusters have the following features and capabilities.

Operational Specifications

Input Power

Nominal

90 to 140 Vac (110 Vac Nominal), 50/60 Hz and/or 62 to 150 Vdc (125 Vdc nominal) for redundant input power models, or 17.3 to 32 Vdc (24 Vdc nominal) for single input models.

Overvoltage

150% of nominal for 5 seconds.

Input Burden

Less than 10 VA and/or 10 W.

Input Sensing

32, 63, 125 Vdc that may vary 0.1 to 1.60 per unit of the nominal voltage.

Input Control

Standard

Dry contact closure.

Optional

4 to 20 mA or 0 to 10 Vdc.

Outputs

Provides an isolated variable output resistance from zero ohms up to the maximum resistance ordered. Either two-terminal or three-terminal potentiometer configuration is available. Resistors are ¼ watt maximum at 70°C (158°F).

Accuracy

Compatible with all Basler Electric voltage regulator, SSE, and system device accuracy rating.

Resolution

Equivalent to a three-turn, simulated rheostat or potentiometer control.

Traverse Time

Programmable for 20, 40, 60, 80, 100, and 120 seconds from limit to limit.

Operating Control Range

Equal to the control range adjustment of the compatible AVRs and control devices.

Autotracking

Less than 1% change in output between Automatic Voltage Regulator and Manual Voltage Control.

Nullmeter Output

–100 μ A to 100 μ A output signal.

Position Indicator Output

0 to 1 mA output signal, 5,000 Ω maximum burden.

General Specifications

Hipot

Withstands 1,500 Vac applied between all customer connected terminals (all terminals shorted together) and ground for one minute.

Surge Withstand Capability

Surge withstand tested according to ANSI/IEEE C37.90a–1974 on 110 Vac/125 Vdc power inputs.

TemperatureOperating Temperature

–40°C to 70°C (–40°F to 158°F)

Storage Temperature

–40°C to 85°C (–40°F to 185°F)

Shock

Withstands 15 G in each of three mutually perpendicular axes.

Vibration

Withstands 2 G swept over the range of 10 to 50 Hz.

UL Recognition

UL recognized per Standard 508, UL File E75380.

Weight

4.5 lb (2.05 kg)

Revision History

Table 26 provides a historical summary of the changes made to this instruction manual. Revisions are listed in chronological order.

Table 26. Instruction Manual Revision History

Manual Revision and Date	Change
J, Sep-97	<ul style="list-style-type: none"> • Revised page 3-5 to include 24 Vdc power supply input • Corrected page 5-8 for Traverse Rate Programming from “PROG, MODE, RAISE, and PREP 1” to “PROG, MODE, and RAISE” • Corrected Table 6-7, <i>Traverse Mode: Pressing Order</i> from “PREP 1” to “PREP 2” • Added Section 8, <i>Manual Change Information</i> • Updated the format of the manual
K, Dec-97	<ul style="list-style-type: none"> • UL Recognition information was added to Section 1 • Labeling in Figure 3-10 was corrected • Input Mode and Traverse Rate Programming Instructions were modified
L, Jan-00	<ul style="list-style-type: none"> • Corrected Table 4-1 to read k ohms instead of kW • Changed the Basler Electric logo on page ii of the <i>Introduction</i>
M-May-00	<ul style="list-style-type: none"> • Added note to Figure 1-2 stating that PLC Input option must be V when Applicability option 8 is selected • Corrected various minor errors
N, Aug-00	<ul style="list-style-type: none"> • Corrected Revision M misprinting of illustrations in Section 3 by replacing Figures 3-5 through 3-10
O, Oct-00	<ul style="list-style-type: none"> • Added the following statement to <i>Pre-Position 1 and 2 Setpoint Programming</i> in Sections 5 and 6: “If the adjustment to the setpoint was made prior to pressing the front panel pushbutton switches PROG, PREP1, press the RAISE and LOWER pushbutton switches once each. If this is not done, the reference adjuster will not recognize the change prior to the attempted programming.”
P, Mar-05	<ul style="list-style-type: none"> • Changed all instances of “press and hold the Reference Adjuster front panel pushbutton switches in the order given:” to “press and release the following front panel pushbuttons in the order given:” • In Table 6-7, changed “slow blink” to “long blink” and “fast blink” to “short blink” • Moved contents of Section 8, <i>Manual Change Information</i> to Revision History page of the manual introduction • In Figures 3-7, 3-8, and 3-10, clarified labeling of terminals 26 and 28 • Added note stating that tracking is available in modes 0 and 3 only
Q	<ul style="list-style-type: none"> • This revision letter not used
R, Sep-15	<ul style="list-style-type: none"> • Updated manual to latest style • Removed <i>Replacement Parts</i> • Added Surge Withstand Capability in the <i>Specifications</i> chapter
S, Sep-17	<ul style="list-style-type: none"> • Added nonvolatile memory caution statement



 **Basler Electric®**
www.basler.com

12570 State Route 143
Highland IL 62249-1074 USA
Tel: +1 618.654.2341
Fax: +1 618.654.2351
email: info@basler.com

No. 59 Heshun Road Loufeng District (N)
Suzhou Industrial Park
215122 Suzhou
P.R. CHINA
Tel: +86 512.8227.2888
Fax: +86 512.8227.2887
email: chinainfo@basler.com

111 North Bridge Road
15-06 Peninsula Plaza
Singapore 179098
Tel: +65 68.44.6445
Fax: +65 68.44.8902
email: singaporeinfo@basler.com