

	www.basler.com +1 618.654.2341 (USA) info@basler.com	Model	ES-81O, ES-81U, and ES-81O/U
		Description	Frequency Relay

Introduction

ES frequency relays provide frequency monitoring and protection for use in single-phase or three-phase applications. Three models are available: the ES-81O provides overfrequency protection, the ES-81U provides underfrequency protection, and the ES-81O/U provides overfrequency and underfrequency protection. Microprocessor-based circuitry enhances functionality and improves performance. Internal diagnostics annunciate when relay function or accuracy is compromised.

Warning!

READ THIS MANUAL. Read this manual before installing or operating your ES series relay. Note all warnings, cautions, and notes in this manual as well as on the product. Failure to follow warning and cautionary labels may result in personal injury or property damage. Exercise caution at all times.

It is the responsibility of the user to ensure that this product is installed, operated, and used for its intended function in the manner specified by this manual or any protection provided by this product may be impaired.

Relay Adjustments

All ES frequency relays are equipped with a Set adjustment for underfrequency trips and/or over-frequency trips. Relays with instantaneous timing have a Reset adjustment which allows the system to recover from load swings before dropping out and resetting the relay. Relays with adjustable timing have a Delay adjustment which prevents premature relay operation during brief system frequency fluctuations.

Relay Output Contacts and Indicators

ES frequency relays come equipped with output contacts and LED indicators. Relay output contacts can be used as an alarm annunciation, a control output, or a tripping signal. Two form-C output contacts and an LED indicator are provided for each protective function. Some models provide the option for an additional pair of form-C auxiliary contacts. Refer to the style chart (Figure 4). A Power LED indicates the presence of adequate sensing voltage when continuously lit and annunciates any relay fault, detected by internal diagnostics when flashing.



Case Sizes

All ES-81O/U models are supplied in a wide case as are ES-81O and ES-81U models with auxiliary contacts (style 1xxxNxA0). All other ES-81O and ES 81U models are supplied in a narrow case.

Special Symbols

Special symbols are located on the ratings label on your ES series relay. These symbols are illustrated and described in Table 1.

Table 1. Special Symbol Descriptions

Symbol	Description
	Caution, Refer to Instructions
	Caution, Risk of Electric Shock

Publication	Revision	<h1>Instructions</h1>	Date	Page
9500100996	J		Jun 2025	1 of 10

Specifications

Operating Power

All units are self-powered.

Nominal Voltage: 120 Vac, 208 Vac, 240 Vac, 380 Vac, 415 Vac, or 480 Vac
(For other nominal voltages, contact Basler Electric.)

Voltage Input

Operating Range: $\pm 25\%$ of nominal rating
Frequency: 50 or 60 Hz
Burden: <2.5 VA per phase for narrow case units, <3 VA per phase for wide case units.
Overload: 2 times nominal for 3 s

Setpoint

Repeatability: ± 0.1 Hz

50 Hz Nominal

Overfrequency Range: 50 to 60 Hz
Underfrequency Range: 40 to 50 Hz

60 Hz Nominal

Overfrequency Range: 60 to 70 Hz
Underfrequency Range: 50 to 60 Hz

Instantaneous Trip (Option)

Adjustable Dropout (Reset): 0.1 to 3.0 Hz
Operating Time: <100 ms

Time Delayed Trip (Option)

Adjustable Time Delay: 0 to 20 s
Fixed Dropout (Reset):
-0.1 Hz for overfrequency
+0.1 Hz for underfrequency

Output

Output contact trip performance is in accordance with IEEE Std C37.90™-2005 and IEC 60255-1.

Contact Type: Two form-C contacts per protective function

Make and Carry for Tripping Duty

30 A, 250 Vdc for 0.2 seconds per IEEE Std C37.90-2005 - IEEE Standard for Relays and Relay Systems
Associated with Electric Power Apparatus; 7 A continuous ac or dc

Break Resistive or Inductive

0.3 A at 125 or 250 Vdc (L/R = 0.04 maximum)

Environment

Operating Temperature: -40 to 70°C (-40 to 158°F)
Storage Temperature: -40 to 85°C (-40 to 185°F)
Temperature Coefficient: 0.02% of nominal per °C (200 ppm/°C)
Relative Humidity: $\leq 95\%$, non-condensing
Ingress Protection: IP50 Case, IP20 Terminals
Pollution: Degree 1
Insulation: Class II
Overvoltage: Category III

Physical

Terminals

Type: Compression screw
Wire Size: 0.5-3.3 mm²/20-12 AWG
Screw Torque: 4.4 to 5.3 in-lb (0.5 to 0.6 N•m)
Mounting (HxD): DIN rail 1.38 x 0.29 inches (35 x 7.5 mm) complies with IEC 60715

Publication 9500100996	Revision J	Instructions	Date Jun 2025	Page 2 of 10
----------------------------------	----------------------	---------------------	-------------------------	------------------------

Size (WxHxD)

Narrow Case: 2.17 x 2.75 x 4.38 inches (55 x 70 x 111 mm)
Wide Case: 3.93 x 2.75 x 4.38 inches (100 x 70 x 111 mm)

Weight

Narrow Case: 0.85 lb (0.38 kg)
Wide Case: 1.10 lb (0.50 kg)

Applicable Standards

IEC

IEC 60255-1 Measuring relays and protection equipment – Part 1: Common requirements (includes all referenced/normative IEC standards)

IEEE

IEEE Std C37.90™-2005 – IEEE Standard for Relays and Relay Systems Associated with Electric Power Apparatus

IEEE Std C37.90.1™-2012 – IEEE Standard for Surge Withstand Capability (SWC) Tests for Relays and Relay Systems Associated with Electric Power Apparatus

IEEE Std C37.90.2™-2004 – IEEE Standard for Withstand Capability of Relay Systems to Radiated Electromagnetic Interference from Transceivers

IEEE Std C37.90.3™-2001 – IEEE Standard for Electrostatic Discharge Tests for Protective Relays

Agency Compliance

UL

This product is listed to applicable Canadian and US safety standards and requirements by UL.

- UL 508
- UL 94 V-0
- CSA C22.2 No. 0
- CSA C22.2 No. 14

CE and UKCA

This product has been evaluated and complies with the relevant essential requirements set forth by the EU legislation and UK Parliament.

EU directives:

- Low Voltage Directive (LVD) 2014/35/EU
- Electromagnetic Compatibility (EMC) 2014/30/EU
- Hazardous Substances (RoHS 2) 2011/65/EU

Harmonized standards used for evaluation:

- EN 50178
- EN 50581
- EN 60255-1
- EN 60255-26
- EN 60255-27
- IEC 61000-6-4

FCC Requirements

This product complies with FCC 47 CFR Part 15.

Publication 9500100996	Revision J	<i>Instructions</i>	Date Jun 2025	Page 3 of 10
----------------------------------	----------------------	----------------------------	-------------------------	------------------------

China RoHS

The following table serves as the declaration of hazardous substances for China in accordance with PRC standard SJ/T 11364-2014. The EFUP (Environment Friendly Use Period) for this product is 40 years.

PRODUCT:	ES-81O, ES-81U, ES-81O/U									
零件名称 Part Name	有害物质 Hazardous Substances									
	铅 Lead (Pb)	汞 Mercury (Hg)	镉 Cadmium (Cd)	六价铬 Hexavalent Chromium (Cr ⁶⁺)	多溴联苯 Polybrominated Biphenyls (PBB)	多溴二苯醚 Polybrominated Diphenyl Ethers (PBDE)	邻苯二甲酸二丁酯 Dibutyl Phthalate (DBP)	邻苯二甲酸丁苄酯 Benzyl butyl phthalate (BBP)	邻苯二甲酸二酯 Bis(2-ethylhexyl) phthalate (BEHP)	邻苯二甲酸二异丁酯 Diisobutyl phthalate (DIBP)
金属零件 Metal parts	O	O	O	O	O	O	O	O	O	O
聚合物 Polymers	O	O	O	O	O	O	O	O	O	O
电子产品 Electronics	X	O	O	O	O	O	O	O	O	O
电缆和互连配件 Cables & interconnect accessories	X	O	O	O	O	O	O	O	O	O
绝缘材料 Insulation material	O	O	O	O	O	O	O	O	O	O

本表格依据 SJ/T11364 的规定编制。

O: 表示该有害物质在该部件所有均质材料中的含量均在 GB/T 26572 规定的限量要求以下。

X: 表示该有害物质至少在该部件的某一均质材料中的含量超出 GB/T 26572 规定的限量要求。

This form was prepared according to the provisions of standard SJ/T11364.

O: Indicates that the hazardous substance content in all homogenous materials of this part is below the limit specified in standard GB/T 26252.

X: Indicates that the hazardous substance content in at least one of the homogenous materials of this part exceeds the limit specified in standard GB/T 26572.

Operation

Instantaneous Trip

Frequency protection in the ES-81O and ES-81U relays with instantaneous trip (style 1xAxN2x0) is adjusted by two controls marked Set and Reset. The ES-81O/U has four controls: Under Set, Over Set, Under Reset, and Over Reset.

Set Control

The ES-81O relay Set control adjusts the overfrequency trip point. When the monitored frequency rises above the trip point established by the Set control, a relay trip occurs. This condition energizes the relay output and lights the red Relay/Over LED. The overfrequency trip point is adjustable from 50 to 60 Hz at 50 Hz nominal and 60 to 70 Hz at 60 Hz nominal.

The ES-81U relay Set control adjusts the underfrequency trip point. When the monitored frequency drops below the trip point established by the Set control, a relay trip occurs. This condition de-energizes the relay output and extinguishes the green Relay/Under LED. The underfrequency trip point is adjustable from 40 to 50 Hz at 50 Hz nominal and 50 to 60 Hz at 60 Hz nominal.

Reset Control

The ES-81O Reset control adjusts the overfrequency dropout point. When the monitored frequency drops below the trip point established by the Reset control, the relay is de-energized and the red Relay/Over LED extinguishes.

Publication 9500100996	Revision J	<h1>Instructions</h1>	Date Jun 2025	Page 4 of 10
----------------------------------	----------------------	-----------------------	-------------------------	------------------------

The ES-81U Reset control adjusts the underfrequency dropout point. When the monitored frequency rises above the trip point established by the Reset control, the relay is energized and the green Relay/Under LED lights.

The overfrequency and underfrequency dropout point is adjustable from 0.1 to 3.0 Hz from the trip point.

Setting Example

An ES-81O relay with a nominal input rating of 60 Hz has the following settings:

- Set - 65 Hz
- Reset - 2 Hz

A trip occurs when the sensed frequency rises above 65 Hz. The relay drops out when the frequency decreases below 63 Hz.

Time Delayed Trip

Frequency protection in the ES-81O and ES-81U relays with Time Delayed trip (style 1xBxN0x0) is adjusted by two controls marked Set and Delay. The ES-81O/U has four controls: Under Set, Over Set, Under Delay, and Over Delay.

Set Control

The ES-81O relay Set control adjusts the overfrequency trip point. When the monitored frequency rises above the trip point established by the Set control for the duration of the adjustable time delay, a relay trip occurs. This condition energizes the relay output and lights the red Relay/Over LED. The overfrequency trip point is adjustable from 50 to 60 Hz at 50 Hz nominal and 60 to 70 Hz at 60 Hz nominal.

The ES-81U relay Set control adjusts the underfrequency trip point. When the monitored frequency drops below the trip point established by the Set control for the duration of the adjustable time delay, a relay trip occurs. This condition de-energizes the relay output and extinguishes the green Relay/Under LED. The underfrequency trip point is adjustable from 40 to 50 Hz at 50 Hz nominal and 50 to 60 Hz at 60 Hz nominal.

Delay Control

The Delay control adjusts the amount of time that the sensed input exceeds the pickup level before a relay trip occurs. The time delay is adjustable from 0 to 20 seconds.

Fixed Reset

An overfrequency dropout occurs when the frequency decreases 0.1 Hz below the trip point; the relay is de-energized and the red Relay/Over LED extinguishes. An underfrequency dropout occurs when the frequency increases 0.1 Hz above the trip point; the relay is energized and the green Relay/Under LED lights.

Setting Example

An ES-81O relay with a nominal input rating of 60 Hz has the following settings:

- Set - 65 Hz
- Delay - 4 seconds

A trip occurs when the sensed frequency remains above 65 Hz for 4 seconds. The relay drops out when the frequency decreases below 64.9 Hz.

Publication 9500100996	Revision J	Instructions	Date Jun 2025	Page 5 of 10
----------------------------------	----------------------	---------------------	-------------------------	------------------------

Installation

ES relays should be installed in a dry location where the ambient temperature remains within the operating temperature range.

ES frequency relays mount on standard DIN rails that comply with IEC 60715. Mounting involves hooking the top edge of the cutout on the base of the case over one edge of the DIN rail. The opposite side of the cutout containing the release clip is then pushed over the opposite side of the DIN rail. To remove or reposition the relay, pull the release clip downward and move the relay as required. Figure 1 shows the dimensions of the ES-81O, ES-81U, and ES-81O/U relays.

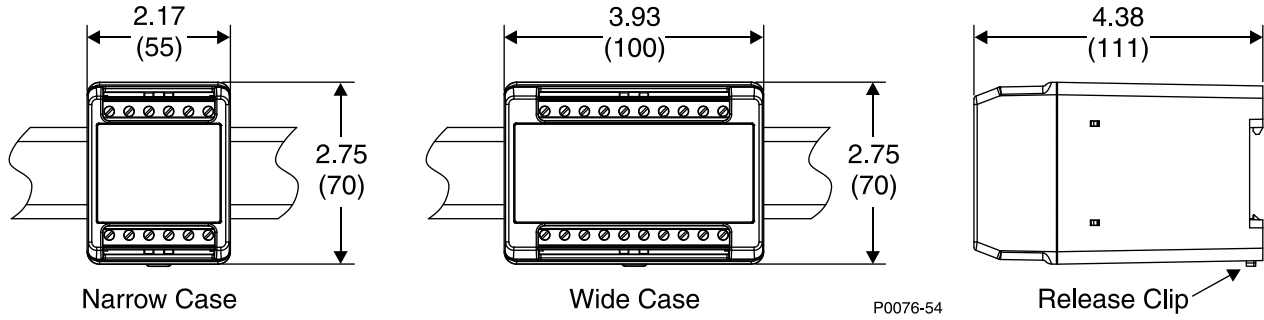

Figure 1. Relay Dimensions

Note

When contact outputs are used to apply dc control voltage to inductive windings, such as relay coils, a flyback diode in parallel with the winding is recommended for EMI suppression. Failure to add such EMI suppression can result in circuit damage.

Relay connections should be made using wire that meets applicable codes and is properly sized for the application. Figure 2 shows the sensing connections for the ES-81O, ES-81U, and ES-81O/U relays. Figure 3 illustrates the front panel appearance of ES 81O and ES-81U relays with optional auxiliary relay outputs (style 1xxxNxAO).

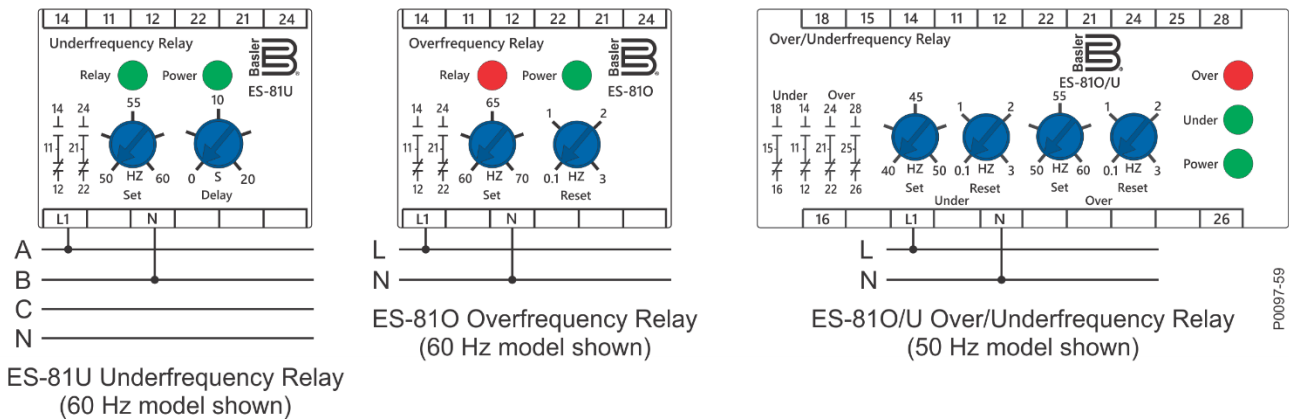
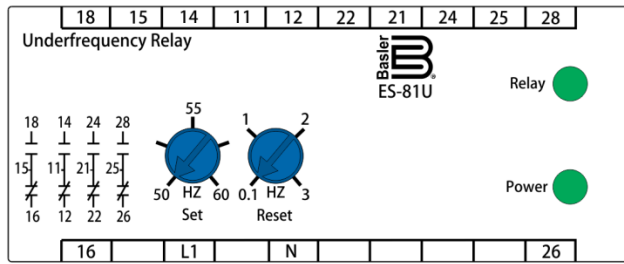
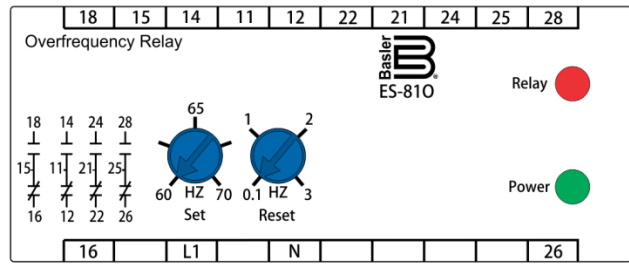

Figure 2. ES-81O, ES-81U, and ES-81O/U Sensing Connections

Publication 9500100996	Revision J	<h1>Instructions</h1>	Date Jun 2025	Page 6 of 10
----------------------------------	----------------------	-----------------------	-------------------------	------------------------



ES-81U Underfrequency Relay
(60 Hz model)



ES-81O Overfrequency Relay
(60 Hz model)

Figure 3. ES-81U and ES-81O Relays with Auxiliary Contact Outputs

Caution

Before commissioning, check the equipment ratings, operating instructions, and installation instructions.

Calibration

The calibration marks on the faceplate are provided only as guides. Proper calibration requires an accurate frequency meter in parallel with the input signal. Use the following procedure to calibrate your relay.

Instantaneous Overfrequency

1. Adjust the Set and Reset controls fully clockwise (CW).
2. Apply the desired trip frequency to the relay.
3. Adjust the Set control counterclockwise (CCW) until the relay trips.
4. Reduce the applied frequency to the desired reset level.
5. Adjust the Reset control CCW until the relay resets.

Instantaneous Underfrequency

1. Adjust the Set control fully CCW and the Reset control fully CW.
2. Apply the desired trip frequency to the relay.
3. Adjust the Set control CW until the relay trips.
4. Increase the applied frequency to the desired reset level.
5. Adjust the Reset control CCW until the relay resets.

Time Delayed Overfrequency

1. Adjust the Set control fully CW and the Delay control fully CCW.
2. Apply the desired trip frequency to the relay.
3. Adjust the Set control CCW until the relay trips.
4. Reduce the applied frequency and set the Delay control to the desired time delay.
5. Increase the applied frequency to a level above the trip level set in Step 3 and measure the time to trip.
6. Adjust the Delay and repeat Steps 4 and 5 until the desired time delay is attained.

Time Delayed Underfrequency

1. Adjust the Set and Delay controls fully CCW.
2. Apply the desired trip frequency to the relay.
3. Adjust the Set control CW until the relay trips.
4. Increase the applied frequency and set the Delay control to the desired time delay.

Publication 9500100996	Revision J	<i>Instructions</i>	Date Jun 2025	Page 7 of 10
----------------------------------	----------------------	----------------------------	-------------------------	------------------------

PC0082-31

5. Reduce the applied frequency to a level below the trip level set in Step 3 and measure the time delay.
6. Adjust the Delay and repeat steps 4 and 5 until the desired time delay is attained.

Maintenance

ES relays require no maintenance. In the event that your relay requires repair, contact Basler Electric, Highland, IL, USA for return authorization.

Ordering Information

Figure 4 shows the ES frequency relay style number identification chart.

Mounting accessories (DIN rails and DIN rail end stops) are available from Basler Electric. Table 2 lists the part numbers for ordering.

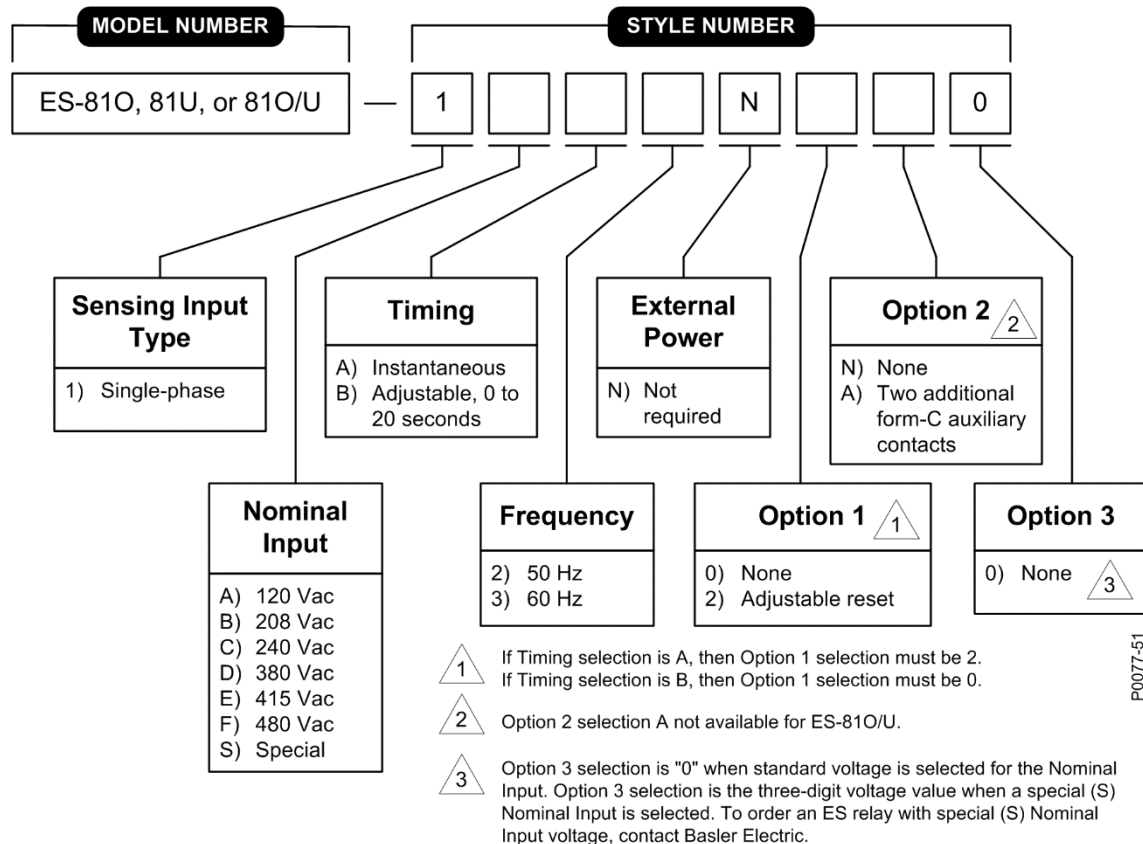

Figure 4. ES-810, ES-81U, and ES-810/U Style Number Identification Chart

Table 2. Mounting Accessories

Mounting Accessories	Basler Part Number
DIN Rail, 3.0 inches (76 mm) wide	9323900001
DIN Rail, 5.5 inches (140 mm) wide	9323900002
DIN Rail, 8.0 inches (203 mm) wide	9323900003
DIN Rail, 39.4 inches (1,000 mm) wide	17366
DIN Rail End Stops	31761

This device utilizes redistributable software code copyrighted by Freescale Semiconductor, Inc. The following copyright notice and disclaimer are provided in this publication as required by the conditions for redistribution.

Copyright: 1997 - 2014 Freescale Semiconductor, Inc. All Rights Reserved.

Redistribution and use in source and binary forms, with or without modification, are permitted provided that the following conditions are met:

- Redistributions of source code must retain the above copyright notice, this list of conditions and the following disclaimer.
- Redistributions in binary form must reproduce the above copyright notice, this list of conditions and the following disclaimer in the documentation and/or other materials provided with the distribution.
- Neither the name of Freescale Semiconductor, Inc. nor the names of its contributors may be used to endorse or promote products derived from this software without specific prior written permission.

THIS SOFTWARE IS PROVIDED BY THE COPYRIGHT HOLDERS AND CONTRIBUTORS "AS IS" AND ANY EXPRESS OR IMPLIED WARRANTIES, INCLUDING, BUT NOT LIMITED TO, THE IMPLIED WARRANTIES OF MERCHANTABILITY AND FITNESS FOR A PARTICULAR PURPOSE ARE DISCLAIMED. IN NO EVENT SHALL THE COPYRIGHT HOLDER OR CONTRIBUTORS BE LIABLE FOR ANY DIRECT, INDIRECT, INCIDENTAL, SPECIAL, EXEMPLARY, OR CONSEQUENTIAL DAMAGES (INCLUDING, BUT NOT LIMITED TO, PROCUREMENT OF SUBSTITUTE GOODS OR SERVICES; LOSS OF USE, DATA, OR PROFITS; OR BUSINESS INTERRUPTION) HOWEVER CAUSED AND ON ANY THEORY OF LIABILITY, WHETHER IN CONTRACT, STRICT LIABILITY, OR TORT (INCLUDING NEGLIGENCE OR OTHERWISE) ARISING IN ANY WAY OUT OF THE USE OF THIS SOFTWARE, EVEN IF ADVISED OF THE POSSIBILITY OF SUCH DAMAGE.

Publication 9500100996	Revision J	<i>Instructions</i>	Date Jun 2025	Page 9 of 10
----------------------------------	----------------------	----------------------------	-------------------------	------------------------



Publication 9500100996	Revision J	<i>Instructions</i>	Date Jun 2025	Page 10 of 10
----------------------------------	----------------------	----------------------------	-------------------------	-------------------------

For terms of service relating to this product and software, see the *Commercial Terms of Products and Services* document available at www.basler.com/terms.