

	www.basler.com +1 618.654.2341 (USA) info@basler.com	Model	ES-74V
		Description	DC Voltage Sensing Relay

Introduction

ES dc voltage sensing relays provide voltage monitoring and protection for applications where dc voltage levels are critical. Three models are available: the ES-74V Over provides overvoltage protection, the ES-74V Under provides undervoltage protection, and the ES-74V Over/Under provides overvoltage and undervoltage protection. Microprocessor-based circuitry enhances functionality and improves performance. Internal diagnostics annunciate when relay function or accuracy is compromised.

Warning!

READ THIS MANUAL. Read this manual before installing or operating your ES series relay. Note all warnings, cautions, and notes in this manual as well as on the product. Failure to follow warning and cautionary labels may result in personal injury or property damage. Exercise caution at all times.

It is the responsibility of the user to ensure that this product is installed, operated, and used for its intended function in the manner specified by this manual or any protection provided by this product may be impaired.

Relay Adjustments

All ES dc voltage sensing relays are equipped with a Set adjustment for undervoltage trips and/or overvoltage trips. The Set adjustment is based on a percentage of the relay's nominal sensing voltage rating. A Delay adjustment prevents premature relay operation during brief voltage fluctuations.

Relay Output Contacts and Indicators

ES dc voltage sensing relays come equipped with output contacts and LED indicators. Relay output contacts can be used as an alarm annunciation, a control output, or a tripping signal. Two form-C output contacts and an LED indicator are provided for each protective function. Some models provide the option for an additional pair of auxiliary contacts. Refer to the style chart (Figure 4). A Power LED indicates the presence of adequate sensing voltage when continuously lit and annunciates any relay fault, detected by internal diagnostics, when flashing.



Case Sizes

ES-74V Over/Under models are supplied in a wide case as are ES-74V Over and ES-74V Under models with auxiliary relay outputs (style 9xB0xA0). All other ES-74V models are supplied in a narrow case.

Special Symbols

Special symbols are located on the ratings label on your ES series relay. These symbols are illustrated and described in Table 1.

Table 1. Special Symbol Descriptions

Symbol	Description
	Caution, Refer to Instructions
	Caution, Risk of Electric Shock

Publication	Revision	<h1>Instructions</h1>	Date	Page
9500100995	J		Jun 2025	1 of 8

Specifications

All units require external operating power.

Nominal Voltage: 120 Vac, 208 Vac, 240 Vac, 380 Vac, 415 Vac, 480 Vac, or 24 Vdc.
AC Operating Range: Nominal $\pm 25\%$
DC Operating Range: Nominal $\pm 20\%$
Frequency: 50 or 60 Hz

Burden

AC Power Supply: <2.5 VA (narrow case)
<3 VA (wide case)
DC Power Supply: <1.5 W

Sensing Input

Nominal Voltage: 1.0 Vdc, 10 Vdc, 100 Vdc, or 125 Vdc
Burden: $\geq 100 \text{ k}\Omega$
Overload: 1.25 times nominal continuously or 2 times nominal for 3 s

Setpoint

Undervoltage Range: Adjustable 5 to 80% of nominal
Overvoltage Range: Adjustable 40 to 120% of nominal
Repeatability: $\pm 0.5\%$
Time Delay: Adjustable 0 to 20 s
Dropout (Reset): Fixed at 1% of nominal

Output

Output contact trip performance is in accordance with IEEE Std C37.90™-2005 and IEC 60255-1.

Contact Type: Two form-C contacts per protective function

Make and Carry for Tripping Duty

30 A, 250 Vdc for 0.2 seconds per IEEE Std C37.90-2005 - IEEE Standard for Relays and Relay Systems
Associated with Electric Power Apparatus; 7 A continuous ac or dc

Break Resistive or Inductive

0.3 A at 125 or 250 Vdc (L/R = 0.04 maximum)

Environment

Operating Temperature: -40 to 70°C (-40 to 158°F)
Storage Temperature: -40 to 85°C (-40 to 185°F)
Temperature Coefficient: 0.02% of nominal per $^\circ\text{C}$ (200 ppm/ $^\circ\text{C}$)
Relative Humidity: $\leq 95\%$, non-condensing
Ingress Protection: IP50 Case, IP20 Terminals
Pollution: Degree 1
Insulation: Class II
Overvoltage: Category III

Physical

Terminals

Type: Compression screw
Wire Size: 0.5-3.3 mm²/20-12 AWG
Screw Torque: 4.4 to 5.3 in-lb (0.5 to 0.6 N•m)
Mounting (HxD): DIN rail 1.38 x 0.29 inches (35 x 7.5 mm) complies with IEC 60715

Size (WxHxD)

Narrow Case: 2.17 x 2.75 x 4.38 inches (55 x 70 x 111 mm)
Wide Case: 3.93 x 2.75 x 4.38 inches (100 x 70 x 111 mm)

Weight

Narrow Case: 0.85 lb (0.38 kg)

Publication 9500100995	Revision J	Instructions	Date Jun 2025	Page 2 of 8
----------------------------------	----------------------	---------------------	-------------------------	-----------------------

Wide Case: 1.10 lb (0.50 kg)

Applicable Standards

IEC

IEC 60255-1 Measuring relays and protection equipment – Part 1: Common requirements (includes all referenced/normative IEC standards)

IEEE

IEEE Std C37.90™-2005 – IEEE Standard for Relays and Relay Systems Associated with Electric Power Apparatus

IEEE Std C37.90.1™-2012 – IEEE Standard for Surge Withstand Capability (SWC) Tests for Relays and Relay Systems Associated with Electric Power Apparatus

IEEE Std C37.90.2™-2004 – IEEE Standard for Withstand Capability of Relay Systems to Radiated Electromagnetic Interference from Transceivers

IEEE Std C37.90.3™-2001 – IEEE Standard for Electrostatic Discharge Tests for Protective Relays

Agency Compliance

UL

This product is listed to applicable Canadian and US safety standards and requirements by UL.

- UL 508
- UL 94 V-0
- CSA C22.2 No. 0
- CSA C22.2 No. 14

CE and UKCA

This product has been evaluated and complies with the relevant essential requirements set forth by the EU legislation and UK Parliament.

EU directives:

- Low Voltage Directive (LVD) 2014/35/EU
- Electromagnetic Compatibility (EMC) 2014/30/EU
- Hazardous Substances (RoHS 2) 2011/65/EU

Harmonized standards used for evaluation:

- EN 50178
- EN 50581
- EN 60255-1
- EN 60255-26
- EN 60255-27
- IEC 61000-6-4

FCC Requirements

This product complies with FCC 47 CFR Part 15.

Publication 9500100995	Revision J	Instructions	Date Jun 2025	Page 3 of 8
----------------------------------	----------------------	---------------------	-------------------------	-----------------------

China RoHS

The following table serves as the declaration of hazardous substances for China in accordance with PRC standard SJ/T 11364-2014. The EFUP (Environment Friendly Use Period) for this product is 40 years.

PRODUCT:	ES-74V									
零件名称 Part Name	有害物质 Hazardous Substances									
	铅 Lead (Pb)	汞 Mercury (Hg)	镉 Cadmium (Cd)	六价铬 Hexavalent Chromium (Cr ⁶⁺)	多溴联苯 Polybrominated Biphenyls (PBB)	多溴二苯醚 Polybrominated Diphenyl Ethers (PBDE)	邻苯二甲酸二丁酯 Dibutyl Phthalate (DBP)	邻苯二甲酸丁苄酯 Benzyl butyl phthalate (BBP)	邻苯二甲酸二酯 Bis(2-ethylhexyl) phthalate (BEHP)	邻苯二甲酸二异丁酯 Diisobutyl phthalate (DIBP)
金属零件 Metal parts	O	O	O	O	O	O	O	O	O	O
聚合物 Polymers	O	O	O	O	O	O	O	O	O	O
电子产品 Electronics	X	O	O	O	O	O	O	O	O	O
电缆和互连配件 Cables & interconnect accessories	X	O	O	O	O	O	O	O	O	O
绝缘材料 Insulation material	O	O	O	O	O	O	O	O	O	O

本表格依据 SJ/T11364 的规定编制。

O: 表示该有害物质在该部件所有均质材料中的含量均在 GB/T 26572 规定的限量要求以下。

X: 表示该有害物质至少在该部件的某一均质材料中的含量超出 GB/T 26572 规定的限量要求。

This form was prepared according to the provisions of standard SJ/T11364.

O: Indicates that the hazardous substance content in all homogenous materials of this part is below the limit specified in standard GB/T 26252.

X: Indicates that the hazardous substance content in at least one of the homogenous materials of this part exceeds the limit specified in standard GB/T 26572.

Operation

DC voltage protection in the ES-74V Over and ES 74V Under relays is adjusted by two controls marked Set and Delay. The ES-74V Over/Under relay has four controls: Under Set, Over Set, Under Delay, and Over Delay.

Set Control

The ES-74V Over relay Set control adjusts the overvoltage trip point. When the monitored voltage rises above the percentage established by the Set control for the duration of the adjustable time delay, a relay trip occurs. This condition energizes the relay output and lights the red Relay/Over LED. The overvoltage trip point is adjustable from 40 to 120% of the nominal input.

The ES-74V Under relay Set control adjusts the undervoltage trip point. When the monitored voltage drops below the percentage established by the Set control for the duration of the adjustable time delay, a relay trip occurs. This condition de-energizes the relay output and extinguishes the green Relay/Under LED. The undervoltage Set level is adjustable from 5 to 80% of nominal input.

Delay Control

The Delay control adjusts the amount of time that the sensed input exceeds the pickup level before a relay trip occurs. The time delay is adjustable from 0 to 20 seconds.

Setting Example

An ES-74V Over relay with a nominal input rating of 100 Vdc has the following setting:

Publication 9500100995	Revision J	Instructions	Date Jun 2025	Page 4 of 8
----------------------------------	----------------------	---------------------	-------------------------	-----------------------

- Set - 80%
- Delay - 4 s

A trip occurs when the sensing voltage remains above 80 Vdc for 4 seconds. Dropout occurs when the voltage falls below 79 Vdc (1% of nominal below the trip point). The relay is de-energized and the red Relay/Over LED extinguishes.

Installation

ES relays should be installed in a dry location where the ambient temperature remains within the operating temperature range.

ES dc voltage sensing relays mount on standard DIN rails that comply with IEC 60715. Mounting involves hooking the top edge of the cutout on the base of the case over one edge of the DIN rail. The opposite side of the cutout containing the release clip is then pushed over the opposite side of the DIN rail. To remove or reposition the relay, pull the release clip downward and move the relay as required. Figure 1 shows the dimensions of the ES-74V relays.

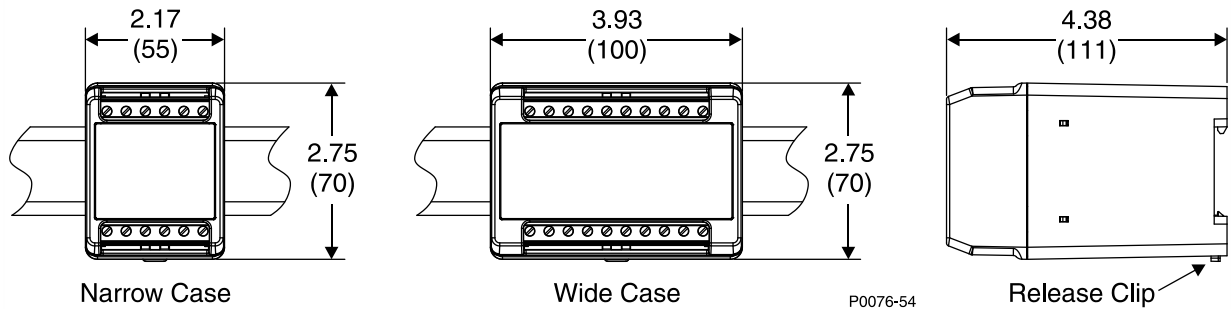

Figure 1. Relay Dimensions

Note

When contact outputs are used to apply dc control voltage to inductive windings, such as relay coils, a flyback diode in parallel with the winding is recommended for EMI suppression. Failure to add such EMI suppression can result in circuit damage.

Relay connections should be made using wire that meets applicable codes and is properly sized for the application. Figure 2 shows the sensing and power connections for the ES-74V relays. Figure 3 illustrates the front panel appearance of ES-74V Under and ES 74V Over relays with optional auxiliary relay outputs (style 9xB0xxA0).

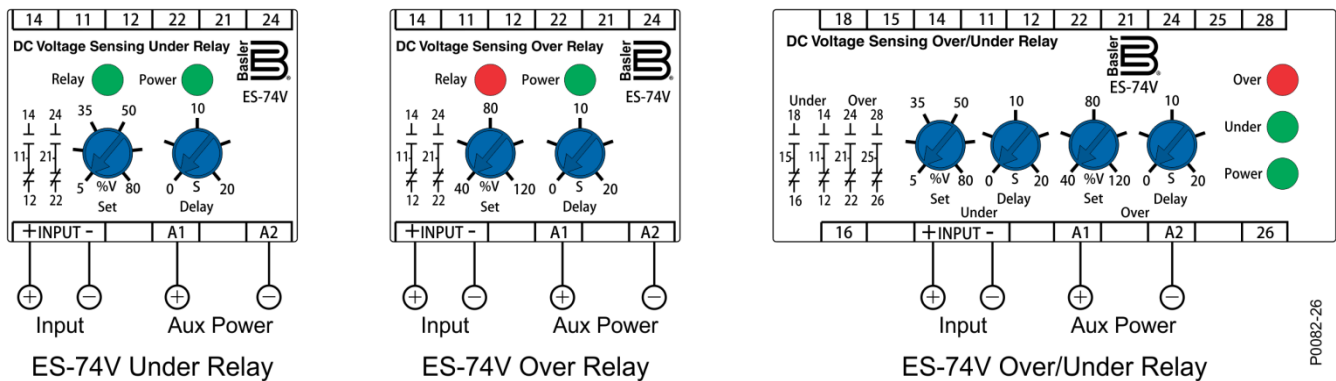

Figure 2. ES-74V Under, ES-74V Over, and ES-74V Over/Under Sensing and Power Connections

Publication 9500100995	Revision J	Instructions	Date Jun 2025	Page 5 of 8
----------------------------------	----------------------	---------------------	-------------------------	-----------------------

Caution

Before commissioning, check the equipment ratings, operating instructions, and installation instructions.

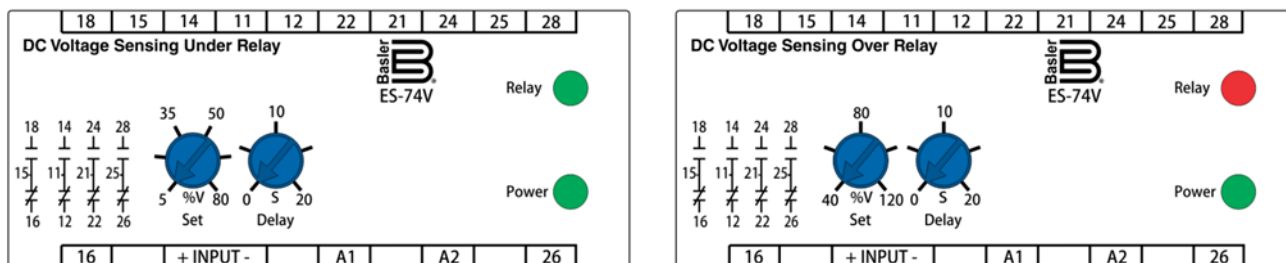

Figure 3. ES74V Under and Over Relays with Auxiliary Contact Outputs

P0082-27

Calibration

The calibration marks on the faceplate are provided only as guides. Proper calibration requires an accurate voltmeter in parallel with the input signal. Use the following procedure to calibrate your relay.

Overvoltage

1. Adjust the Set control fully clockwise (CW) and the Delay control fully counterclockwise (CCW).
2. Apply the desired trip voltage to the relay.
3. Adjust the Set control CCW until the relay trips.
4. Decrease the applied voltage and set the Delay control to the desired time delay.
5. Increase the applied voltage to a level above the trip level set in Step 3 and measure the time to trip.
6. Adjust the Delay and repeat Steps 4 and 5 until you have the desired time delay.

Undervoltage

1. Adjust the Set and Delay controls fully CCW.
2. Apply the desired trip voltage to the relay.
3. Adjust the Set control CW until the relay trips.
4. Increase the applied voltage and set the Delay control to the desired time delay.
5. Decrease the applied voltage to a level below the trip level set in Step 3 and measure the time to trip.
6. Adjust the Delay and repeat Steps 4 and 5 until the desired time delay is achieved.

Maintenance

ES relays require no maintenance. In the event that your relay requires repair, contact Basler Electric, Highland, IL, USA for return authorization.

Ordering Information

Mounting accessories (DIN rails and DIN rail end stops) are available from Basler Electric. Table 2 lists the part numbers for ordering.

Table 2. Mounting Accessories

Mounting Accessories	Basler Part Number
DIN Rail, 3.0 inches (76 mm) wide	9323900001
DIN Rail, 5.5 inches (140 mm) wide	9323900002

Publication 9500100995	Revision J	<i>Instructions</i>	Date Jun 2025	Page 6 of 8
----------------------------------	----------------------	---------------------	-------------------------	-----------------------

For terms of service relating to this product and software, see the *Commercial Terms of Products and Services* document available at www.basler.com/terms.

Mounting Accessories	Basler Part Number
DIN Rail, 8.0 inches (203 mm) wide	9323900003
DIN Rail, 39.4 inches (1,000 mm) wide	17366
DIN Rail End Stops	31761

Figure 4 shows the ES dc voltage sensing relay style number identification chart.

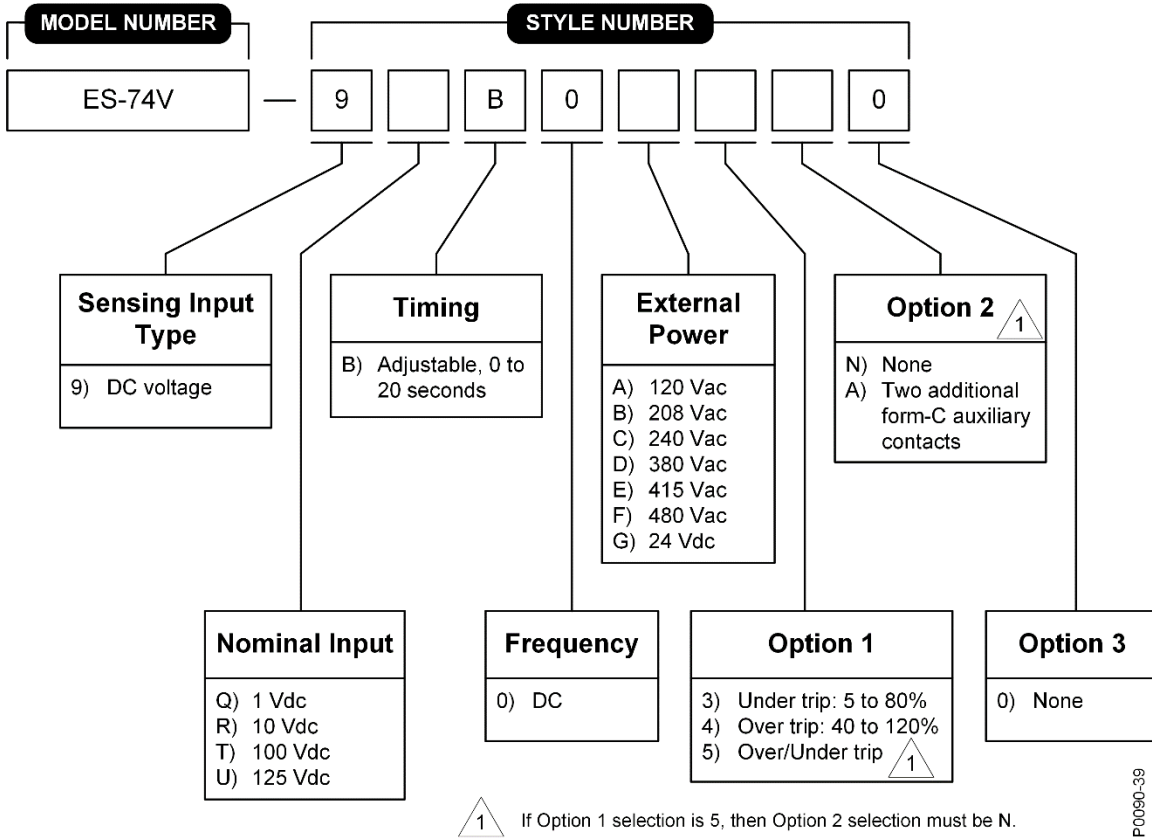

Figure 4. ES-74V Style Number Identification Chart

This device utilizes redistributable software code copyrighted by Freescale Semiconductor, Inc. The following copyright notice and disclaimer are provided in this publication as required by the conditions for redistribution.

Copyright: 1997 - 2014 Freescale Semiconductor, Inc. All Rights Reserved.

Redistribution and use in source and binary forms, with or without modification, are permitted provided that the following conditions are met:

- Redistributions of source code must retain the above copyright notice, this list of conditions and the following disclaimer.
- Redistributions in binary form must reproduce the above copyright notice, this list of conditions and the following disclaimer in the documentation and/or other materials provided with the distribution.
- Neither the name of Freescale Semiconductor, Inc. nor the names of its contributors may be used to endorse or promote products derived from this software without specific prior written permission.

THIS SOFTWARE IS PROVIDED BY THE COPYRIGHT HOLDERS AND CONTRIBUTORS "AS IS" AND ANY EXPRESS OR IMPLIED WARRANTIES, INCLUDING, BUT NOT LIMITED TO, THE IMPLIED WARRANTIES OF MERCHANTABILITY AND FITNESS FOR A PARTICULAR PURPOSE ARE DISCLAIMED. IN NO EVENT SHALL THE COPYRIGHT HOLDER OR CONTRIBUTORS BE LIABLE FOR ANY DIRECT, INDIRECT, INCIDENTAL, SPECIAL, EXEMPLARY, OR CONSEQUENTIAL DAMAGES (INCLUDING, BUT NOT LIMITED TO, PROCUREMENT OF SUBSTITUTE GOODS OR SERVICES; LOSS OF USE, DATA, OR PROFITS; OR BUSINESS INTERRUPTION) HOWEVER CAUSED AND ON ANY THEORY OF LIABILITY, WHETHER IN CONTRACT, STRICT LIABILITY, OR TORT (INCLUDING NEGLIGENCE OR OTHERWISE) ARISING IN ANY WAY OUT OF THE USE OF THIS SOFTWARE, EVEN IF ADVISED OF THE POSSIBILITY OF SUCH DAMAGE.

Publication 9500100995	Revision J	Instructions	Date Jun 2025	Page 7 of 8
----------------------------------	----------------------	---------------------	-------------------------	-----------------------



Publication 9500100995	Revision J	<i>Instructions</i>	Date Jun 2025	Page 8 of 8
----------------------------------	----------------------	----------------------------	-------------------------	-----------------------

For terms of service relating to this product and software, see the *Commercial Terms of Products and Services* document available at www.basler.com/terms.