

INSTRUCTIONS

Basler Electric
Phone: +1 618.654.2341
Route 143, Box 269
Highland IL 62249 USA

FOR DGC-50

Power Systems Group
Fax: +1 618.654.2351
www.basler.com
info@basler.com

INTRODUCTION

The DGC-50 controller provides key-switch starting and stopping of an engine, automatic control of engine glow plugs, and front-panel annunciation of engine/genset conditions. The DGC-50 provides protection by automatically shutting down the engine when abnormal operating conditions are detected.

FEATURES

DGC-50 features include the following:

- Rugged design makes the DGC-50 suitable for direct mounting on an engine
- Accepts 12 or 24 Vdc battery power
- Engine starting and stopping through front panel key switch or remotely located key switch
- IEC IP54 front panel rating when key switch is mounted remotely (DGC-50 style XR)
- CE compliant
- Automatic timer-controlled energizing of engine glow plugs through key switch
- Engine speed detection through magnetic pickup (style 3X) or generator frequency (style 1X or 2X)
- Four sets of output contacts provide glow plug control, fuel solenoid control, engine cranking control, and alarm annunciation
- Front panel indicators (LEDs) annunciate engine overspeed, loss of the engine speed source, battery charger failure, low oil pressure, high coolant temperature, preheat/glow plug circuit energized, and engine shutdown from auxiliary input
- Auxiliary contact input permits remote shutdown of engine

STYLE NUMBER

DGC-50 feature and operating characteristics are defined by a two-digit style number. The DGC-50 style number chart is illustrated in Figure 1.

SPECIFICATIONS

Control Power

Control power input accepts 12 or 24 Vdc battery voltage and has reverse polarity protection.

Range: 8 to 36 Vdc
Terminals: 12 (-), 14 (+)

Engine Speed Input

Engine speed is determined by the frequency of the generator voltage (style 1X or 2X) or by a user-supplied, magnetic pickup (style 3X).

Styles 1X and 2X (Generator Voltage)

Voltage Range: 12 to 300 Vac
Frequency Range
Style 1X (50/60 Hz): 4 to 70 Hz
Style 2X (400 Hz): 4 to 450 Hz
Terminals: 13 (N), 15 (L)

Style 3X (Magnetic Pickup)

Voltage Range: 3 to 25 Vac
(8.5 to 70 V_{p-p})
Frequency Range: 2,300 to 6,000 Hz
Terminals: 13 (N), 15 (L)

Contact Inputs

Type: Normally-open, dry contacts

Activation Delay

Low Oil Pressure: 10 s after cranking is terminated
High Coolant Temp: 60 s after engine is started
Auxiliary Shutdown: No intentional delay
Battery Charger Fail: 10 s after cranking is terminated

Terminals

Low Oil Pressure: 10, 12
High Coolant Temp: 11, 12
Auxiliary Shutdown: 9, 12
Battery Charger Fail: 8, 12

Control Outputs

Control outputs consist of Fuel Solenoid, Glow Plug, Crank, and Alarm.

Configuration: Form A (SPST)
Rating: 5 Adc at 36 Vdc, inductive (ext. fly-back diode required)

Terminals

Fuel Solenoid: 3, 12
Glow Plugs: 1, 2
Crank: 7, 12
Alarm: 4, 12

Type Tests

Vibration: IEC 255-21-1 (1988)
Shock: IEC 255-21-2 (1988)
Seismic: IEC 255-21-3 (1993)
Humidity: 95% noncondensing

Physical

Temperature

Operating: -40 to 70°C
(-40 to 158°F)
Storage: -40 to 85°C
(-40 to 185°F)

Weight

Style XL: 369 g (13 oz)
Style XR: 272 g (10 oz)

Terminations

Type: Compression
Screw Torque: 7 in-lb (0.791 N•m)

Maximum Conductor Size

Stranded Wire: 14 AWG or 1.5 mm²
Solid Wire: 12 AWG or 2.5 mm²

FUNCTIONAL DESCRIPTION

DGC-50 functional elements are described in the following paragraphs.

Control Power

The control power input accepts dc voltage over the range of 8 to 36 Vdc at DGC-50 terminals 12 (-) and 14 (+). Applying control power of the wrong polarity will not damage the DGC-50.

Controls

DGC-50 controls consist of a key switch and an overspeed setpoint control.

Key Switch

A three-position key switch provides control of the engine and DGC-50.

The key switch is mounted on the front panel of a DGC-50 with a style number of XL. A DGC-50 with a style number of XR uses a key switch that is mounted remotely by the user. This configuration gives the DGC-50 front panel an IEC IP54 rating and makes it immune to splashing from any direction and deposits of dust.

Key-switch positions consist of 0 (Stop), I (Run), and II (Start/Crank).

Position 0 is used to stop the engine by de-energizing the Fuel Solenoid output at DGC-50 terminal 3. It also resets all active DGC-50 alarms.

Position I enables the engine to run by applying battery voltage to the DGC-50 Fuel Solenoid output (terminal 3). Before starting the engine, the key-switch can be placed in position I to close the Preheat (glow-plugs) output contacts at DGC-50 terminals 1 and 2. The Preheat output contacts will remain closed for 60 seconds or until the key switch is placed in the Start position.

Holding the key switch in position II initiates engine cranking by energizing the Start output at DGC-50 terminal 7. The Start output remains energized for as long as the key is held in position II. When the key is released, the key switch automatically returns to the Run position.

Overspeed Setpoint Control

The screwdriver-adjusted overspeed setpoint control is accessed through a hole in the DGC-50 rear panel. The setting of the control determines the engine frequency (speed) where an overspeed condition is annunciated and engine shutdown is initiated. Engine overspeed is annunciated by the DGC-50 Engine Overspeed LED on the front panel. Engine shutdown is initiated 500 milliseconds after overspeed detection by de-energizing the Fuel Solenoid output at DGC-50 terminal 3.

DGC-50 controllers that use a magnetic pickup (MPU) as the engine speed source (style 3X) have a minimum overspeed adjustment range of 2,300 to 6,000 hertz and are factory-preset at 3,000 Hz $\pm 2\%$. DGC-50 controllers that use generator frequency (genset applications) as the engine speed source (style 1X or 2X) have a minimum overspeed adjustment range of 105 to 140% of synchronous genset speed and are factory preset at 114% $\pm 2\%$.







Clockwise rotation of the overspeed setpoint control increases the overspeed setpoint and counterclockwise rotation decreases the overspeed setpoint.

Publication 9388600990	Revision —		First Printing: 01/06 Revised:	Copyright 2006
---------------------------	---------------	--	-----------------------------------	-------------------

Indicators

Seven front-panel LEDs indicate the status of the DGC-50 alarms, auxiliary shutdown contact input, and the Preheat output. Table 1 lists each indicator icon and gives a brief description of each indicator function.

Table 1. Indicator Functions

Icon	Indicator Function
	Engine overspeed
	Loss of engine speed signal
	Battery charger failure
	Low engine oil pressure
	High engine coolant temperature
	Engine shutdown initiated by Auxiliary contact input
	Preheat contacts closed

Outputs

Outputs consist of Preheat, Fuel Solenoid, and Common Alarm output contacts.

Preheat Output Contacts

The Preheat output contacts are used to energize the engine glow plugs prior to engine startup. The Preheat output contacts close when the key switch is moved from position 0 (Stop) to position I (Run). The Preheat output contacts remain closed for 60 seconds or until the key-switch is moved from position I to position II (Start). If the engine fails to start and further preheating is necessary, the key switch must be placed in position 0 before returning it to position I. Preheat output contact connections are made at terminals 1 and 2.

Fuel Solenoid Output

The Fuel Solenoid output (terminal 3) energizes when the key switch is placed in the Run (I) position and remains energized when the key switch is moved to the Start (II) position. Placing the key switch in the Stop (0) position de-energizes the Fuel Solenoid output.

The same conditions that cause the DGC-50 to energize the Common Alarm output also cause the Fuel Solenoid output to de-energize. Once de-energized, the Fuel Solenoid output cannot be re-energized before the DGC-50 is reset by placing the key switch in the Stop (0) position.

Protection Functions

DGC-50 protection features include:

- Engine overspeed
- Loss of engine speed source
- High engine coolant temperature
- Low engine oil pressure

Engine Overspeed

When the engine speed exceeds the user-adjustable overspeed threshold, the DGC-50 responds by de-energizing the Fuel Solenoid output (terminal 3), energizing the Common Alarm output (terminal 4), and lighting the Engine Overspeed indicator. A fixed, 500 millisecond overspeed time delay prevents false tripping during load transient conditions. An overspeed shutdown annunciation is reset by placing the DGC-50 key switch in the Stop (0) position.

The overspeed threshold is adjusted by a multi-turn potentiometer located adjacent to the DGC-50 terminal blocks. A DGC-50 that monitors the engine speed through the frequency of the genset voltage (styles 1X and 2X) has a minimum overspeed adjustment range that is 105 to 140% of the genset synchronous speed. A DGC-50 that monitors the engine speed through a user-supplied MPU has a minimum overspeed adjustment range of 2,300 to 6,000 hertz.

Loss of Engine Speed Source

Loss of the engine speed source is detected when the engine frequency signal is no longer detected by the DGC-50. The DGC-50 responds to a loss of speed source by de-energizing the Fuel Solenoid output (terminal 3), energizing the Common Alarm output (terminal 4), and lighting the Loss of Engine Speed Signal LED indicator. A fixed, 500 millisecond underspeed time delay prevents false tripping during load transient conditions. A loss of speed source shutdown is reset by placing the DGC-50 key in the Stop (0) position.

High Coolant Temperature

Following a fixed, 60-second delay after engine startup, the DGC-50 continuously monitors for high engine temperature through a user-supplied coolant overtemperature switch connected to the High Coolant Temperature contact input at terminal 11. When the coolant overtemperature switch closes and energizes the High Coolant Temperature contact input, the DGC-50 responds by de-energizing the Fuel Solenoid output (terminal 3), energizing the Common Alarm output (terminal 4), and lighting the High Engine Coolant Temperature LED indicator. A high coolant temperature shutdown is reset by placing the DGC-50 key in the Stop (0) position.

Low Oil Pressure

Following a fixed, 10-second delay after engine startup, the DGC-50 continuously monitors for low engine oil pressure through a user-supplied, low oil-pressure switch connected to the DGC-50 Low Oil Pressure contact input at terminal 10. When the low oil pressure switch closes and energizes the Low Oil Pressure contact input, the DGC-50 responds by de-energizing the Fuel Solenoid output (terminal 3), energizing the Common Alarm output (terminal 4), and lighting the Low Engine Oil Pressure LED indicator. A low oil pressure shutdown is reset by placing the DGC-50 key in the Stop (0) position.

Contact Inputs

The DGC-50 has inputs for monitoring the contacts of a low oil pressure switch, a high coolant temperature switch, and a set of battery charger failure contacts. A fourth contact input enables engine shutdown through an external switch.

Low Oil Pressure

A low oil pressure switch, connected to terminals 10 and 12, enables the DGC-50 to monitor for low engine oil pressure. If the engine oil pressure decreases below the switch pressure threshold, the switch contacts close and place a short-circuit across terminals 10 and 12. The DGC-50 re-

sponds by de-energizing the Fuel Solenoid output (terminal 3), energizing the Common Alarm output (terminal 4), and lighting the Low Engine Oil Pressure indicator. The Low Oil Pressure contact input will not respond to a switch closure for the first 10 seconds following the termination of engine cranking.

High Coolant Temperature

A high coolant temperature switch, connected to terminals 11 and 12, enables the DGC-50 to monitor for high engine coolant temperature. If the engine coolant temperature exceeds the temperature threshold of the switch, the switch contacts close and place a short-circuit across terminals 11 and 12. The DGC-50 responds by de-energizing the Fuel Solenoid output (terminal 3), energizing the Common Alarm output (terminal 4), and lighting the High Engine Coolant Temperature indicator. The High Coolant Temperature contact input will not respond to a switch closure for the first 60 seconds following the termination of engine cranking.

Battery Charger Failure

A set of normally-open (NO) battery charger failure contacts, connected to terminals 8 and 12, enables the DGC-50 to monitor for a battery charger/alternator failure. A battery charger failure closes the battery charger failure contacts which place a short-circuit across terminals 8 and 12. The DGC-50 responds by lighting the Battery Charger Failure indicator. The Battery Charger Failure contact input will not respond to a contact closure during the first 10 seconds following the termination of engine cranking. During cranking and the 10 seconds following cranking, terminals 8 (+) and 12 (-) can supply excitation current to the charging alternator.

Auxiliary Contact Input

A momentary, normally-open (NO) switch, connected across terminals 9 and 12, can be used to stop the engine from a remote location. Closing the switch causes the DGC-50 to de-energize the Fuel Solenoid output (terminal 3), energize the Common Alarm output (terminal 4), and light the Auxiliary Shutdown indicator. An auxiliary shutdown is reset by placing the DGC-50 key switch in the Stop (0) position.

INSTALLATION

DGC-50 mounting, connection, and product registration information is provided in the following paragraphs.

Mounting

Overall DGC-50 dimensions are illustrated in Figure 2. Panel cutting and drilling dimensions are shown in Figure 3. Mounting dimensions for the key switch (Basler part number 9388603100) are provided in Figure 4. All dimensions are shown in inches with millimeters in parenthesis.

Secure the DGC-50 using #8 or M4 commercial-grade, low-carbon steel hardware. The torque applied to the hardware should be 20 inch-pounds (2.26 N•m). The mounting hardware selected should be able to withstand the level of vibration and shock that the DGC-50 will be exposed to.

Page 2	First Printing: 01/06 Revised:		Revision —	Publication 9388600990
-----------	-----------------------------------	---	---------------	---------------------------

Connections

Terminal locations/functions are shown in Figure 5 for the key switch (used with style XR DGC-50 controllers). Typical connections for DGC-50 style XL controllers are shown in Figure 6. Typical connections for DGC-50 style XR controllers are shown in Figure 7.

Product Registration

Registering with Basler Electric enables you to receive important updates on your product plus new product announcements. Register your product by directing your web browser to www.basler.com/register.

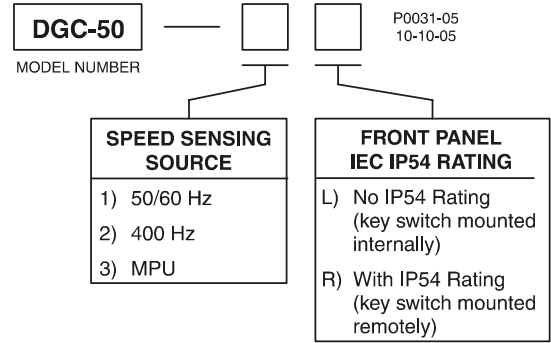
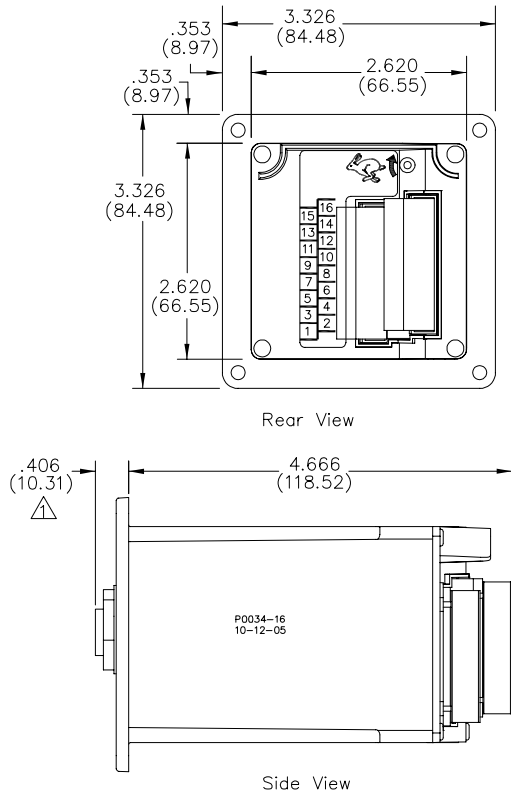

Figure 1. Style Chart



Dimension does not apply to style XR.

Figure 2. DGC-50 Overall Dimensions

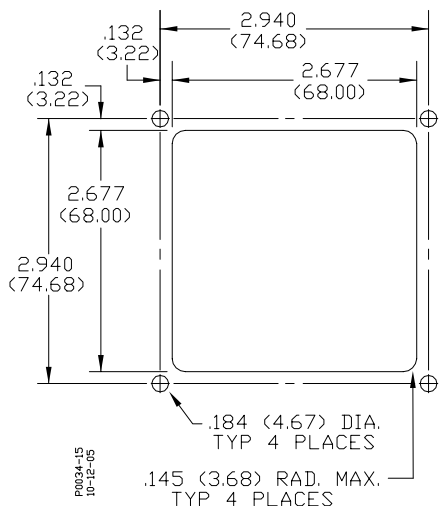

Figure 3. Panel Cutting and Drilling Dimensions

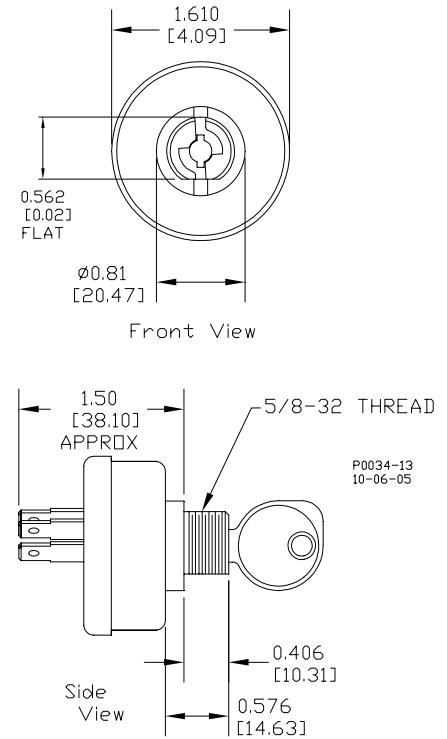
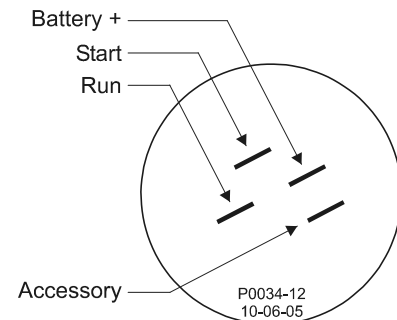
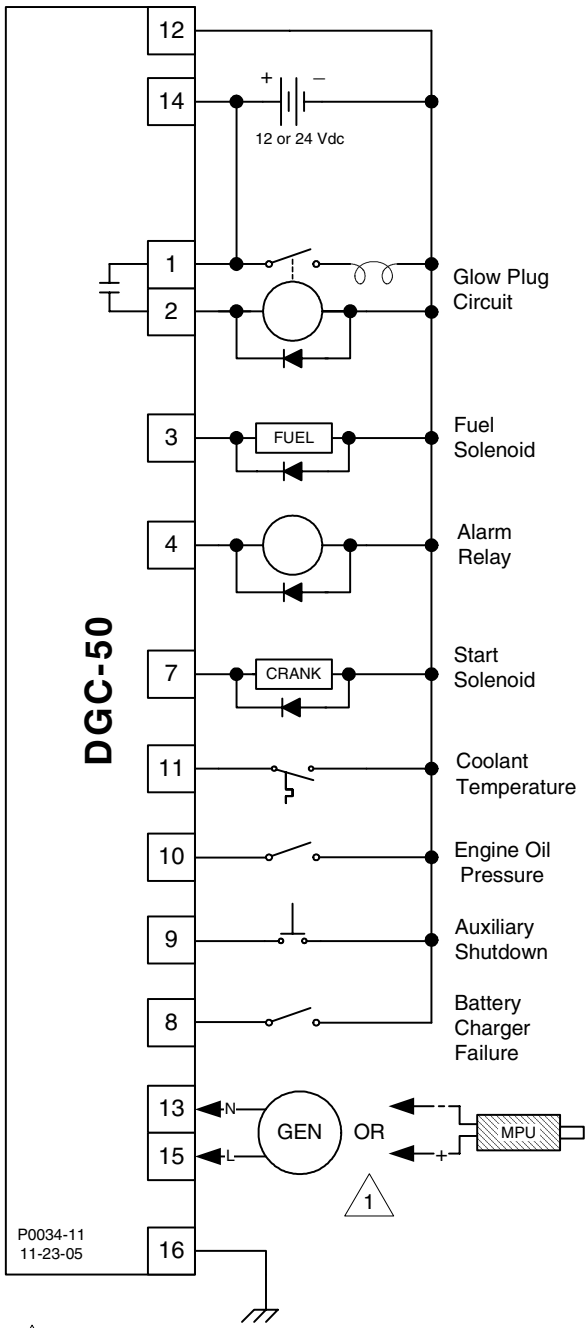

Figure 4. Key Switch Overall Dimensions



Position	Circuits Made
Off (0)	None
Run (I)	Batt. + and Run and Assy.
Start (II)	Batt. + and Run and Start

Figure 5. Key Switch Terminal Locations/Functions



1 Genset speed source is genset output voltage (styles 1X and 2X) or magnetic pickup (style 3X).

Figure 6. Typical Connections, Style XL

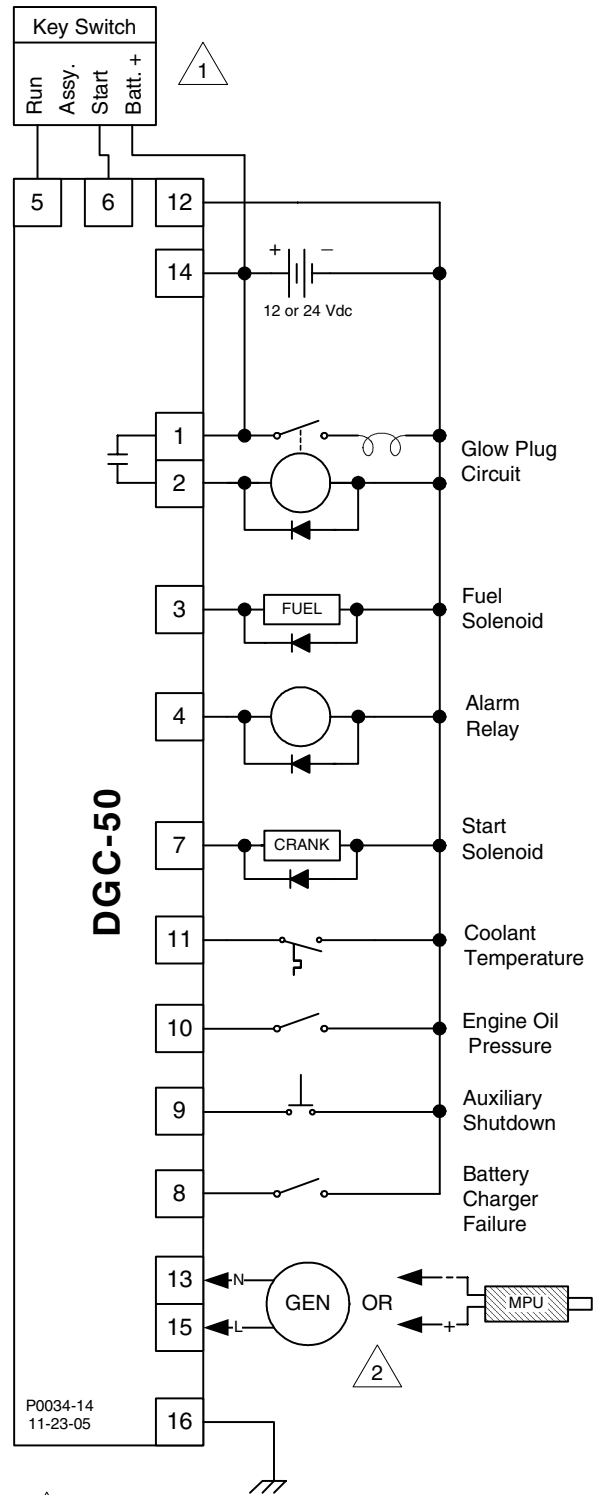

1 Not supplied with DGC-50. If IEC IP54 rating is required, switch suitable for IP 54 must be purchased.

2 Genset speed source is genset output voltage (styles 1X and 2X) or magnetic pickup (style 3X).

Figure 7. Typical Connections, Style XR