




DECS-150

Digital Excitation Control System

Instruction Manual



 **WARNING:** California's Proposition 65 requires special warnings for products that may contain chemicals known to the state of California to cause cancer, birth defects, or other reproductive harm. Please note that by posting this Proposition 65 warning, we are notifying you that one or more of the Proposition 65 listed chemicals may be present in products we sell to you. For more information about the specific chemicals found in this product, please visit <https://www.basler.com/Prop65>.

Preface

This instruction manual provides information about the installation and operation of the DECS-150 Instruction Manual. To accomplish this, the following information is provided:

- General information
- Functional description
- Installation and connections
- BESTCOMSPi^{us}® software
- Communication and configuration
- Testing and troubleshooting
- Specifications

Conventions Used in this Manual

Important safety and procedural information is emphasized and presented in this manual through warning, caution, and note boxes. Each type is illustrated and defined as follows.

Warning!

Warning boxes call attention to conditions or actions that may cause personal injury or death.

Caution

Caution boxes call attention to operating conditions that may lead to equipment or property damage.

Note

Note boxes emphasize important information pertaining to installation or operation.



12570 State Route 143
Highland IL 62249-1074 USA

www.basler.com
info@basler.com

Tel: +1 618.654.2341

Fax: +1 618.654.2351

© 2024 by Basler Electric

All rights reserved

First printing: September 2015

Warning!

READ THIS MANUAL. Read this manual before installing, operating, or maintaining this equipment. Note all warnings, cautions, and notes in this manual as well as on the product. Keep this manual with the product for reference. Only qualified personnel should install, operate, or service this system. Failure to follow warning and cautionary labels may result in personal injury or property damage. Exercise caution at all times.

Caution

Installing previous versions of firmware may result in compatibility issues causing the inability to operate properly and may not have the enhancements and resolutions to issues that more recent versions provide. Basler Electric highly recommends using the latest version of firmware at all times. Using previous versions of firmware is at the user's risk and may void the warranty of the unit.

Basler Electric does not assume any responsibility to compliance or noncompliance with national code, local code, or any other applicable code. This manual serves as reference material that must be well understood prior to installation, operation, or maintenance.

For terms of service relating to this product and software, see the *Commercial Terms of Products and Services* document available at www.basler.com/terms.

This publication contains confidential information of Basler Electric Company, an Illinois corporation. It is loaned for confidential use, subject to return on request, and with the mutual understanding that it will not be used in any manner detrimental to the interests of Basler Electric Company and used strictly for the purpose intended.

It is not the intention of this manual to cover all details and variations in equipment, nor does this manual provide data for every possible contingency regarding installation or operation. The availability and design of all features and options are subject to modification without notice. Over time, improvements and revisions may be made to this publication. Before performing any of the following procedures, contact Basler Electric for the latest revision of this manual.

The English-language version of this manual serves as the only approved manual version.

Revision History

A historical summary of the changes made to this instruction manual is provided below. Revisions are listed in reverse chronological order.

Visit <http://www.basler.com> to download the latest hardware, firmware, and BESTCOMSP^{Plus}® revision histories.

Instruction Manual Revision History

Manual Revision and Date	Change
K, Dec 2024	<ul style="list-style-type: none"> Added Load Shed Control description Added System In Use notification description Added Security Log description Added Operating Modes description Added Network Overload alarm description Removed BESTCOMSP^{Plus} activation requirement Updated names of PSS Modbus registers Minor text edits throughout manual
J, Dec 2023	<ul style="list-style-type: none"> Added China RoHS compliance
I	<ul style="list-style-type: none"> This revision letter not used
H, Sep 2021	<ul style="list-style-type: none"> Adjusted all front panel illustrations to show updated LED labeling Added clarification about the DECS-150 sensing and responding to rms voltage Corrected explanation of the exciter diode monitor's ripple calculation Corrected the DECS-150's breaker shunt trip output rating Added grid code and UKCA compliance statements Added caution statement about downgrading DECS-150 firmware Corrected unit of measure used by the stator current limiter
G, Jan 2021	<ul style="list-style-type: none"> Added description of Tracking Comms Loss alarm Added description of Auto Transfer Enable logic block
F, Apr 2020	<ul style="list-style-type: none"> Added Figure 17-4, <i>Typical Connections</i> for motor applications Added note about time settings in <i>Timekeeping</i> section Added register 1230, Field Voltage Meter, in the <i>Modbus Communication</i> section Minor text edits throughout manual
E, Sep 2019	<ul style="list-style-type: none"> Added support for firmware version 2.04.00 and BESTCOMSP^{Plus} version 4.00.00 Removed Rev Letter from all pages Changed sequential numbering to sectional numbering Moved <i>Instruction Manual Revision History</i> into <i>Preface</i> Removed standalone <i>Revision History</i> section
D, April 2019	<ul style="list-style-type: none"> Added support for firmware version 2.03.00 and BESTCOMSP^{Plus} version 3.21.00 Minor text edits throughout manual
C1, Oct 2018	<ul style="list-style-type: none"> Added California Proposition 65 warning on back of cover page
C, Jan 2018	<ul style="list-style-type: none"> Added information on external tracking, network load sharing, and Modbus Added description of Underfrequency Limiter Reset Time setting

Manual Revision and Date	Change
B, Mar 2017	<ul style="list-style-type: none"> • Added caution statement about nonvolatile memory • Added power dissipation and maximum elevation specifications • Added manual USB driver installation instructions • Clarified current-sensing requirements for PSS operation • Corrected description of online OEL operation
A, Jul 2016	<ul style="list-style-type: none"> • Added information on the backup battery for the real-time clock • Updated connections for Programmable Contact Inputs in the <i>Typical Connections</i> section • Added <i>Ethernet Setup</i> in the <i>Communications</i> section • Updated Generator and Bus Voltage Sensing Ranges in the <i>Specifications</i> section • Added Ingress Protection Ratings in the <i>Specifications</i> section • Updated Maritime Recognition specifications • Minor text edits throughout manual
—, Sep 2015	<ul style="list-style-type: none"> • Initial release

Contents

Introduction.....	1-1
Front Panel.....	2-1
Power Input and Outputs	3-1
Voltage and Current Sensing.....	4-1
Regulation	5-1
Auxiliary Control	6-1
Contact Inputs and Outputs	7-1
Protection	8-1
Limiters.....	9-1
Grid Code.....	10-1
Metering	11-1
Reports.....	12-1
Power System Stabilizer	13-1
Stability Tuning.....	14-1
Mounting.....	15-1
Terminals and Connectors	16-1
Typical Connections	17-1
BESTCOMSP <i>Plus</i> ® Software	18-1
BESTlogic™ <i>Plus</i>	19-1
Communication	20-1
Configuration.....	21-1
Security	22-1
Timekeeping.....	23-1
Testing.....	24-1
Modbus Communication	25-1
Maintenance.....	26-1
Troubleshooting	27-1
Specifications	28-1
BESTCOMSP <i>Plus</i> ® Settings Loader Tool.....	29-1



1 • Introduction

DECS-150 Digital Excitation Control Systems offer precise excitation control and machine protection in a compact package. DECS-150 adaptability to many applications is assured through configurable contact inputs and outputs, flexible communication capabilities, and programmable logic implemented with the provided BESTCOMSP^{Plus}® software.

Applications

The DECS-150 is intended for brushless ac synchronous generator or synchronous motor applications. The DECS-150 controls the machine output through the application of regulated dc excitation power to the exciter field. The level of excitation power is based on the monitored voltage and current, and a regulation setpoint established by the user. The operating mode, generator or motor, is changed on the Operating Mode settings screen. Power factor and var metering values will be opposite in motor mode.

Excitation power is supplied from the DECS-150 by means of a filtered, switching power module that uses pulse-width modulation. It is capable of supplying 7 Adc (70°C ambient) continuously and 10 Adc (55°C ambient) continuously at nominal voltages of 63 or 125 Vdc. With nominal operating voltage applied, it has a forcing capability of 11 Adc for 10 seconds (70°C ambient) or 14 Adc for 10 seconds (55°C ambient).

Features and Functions

DECS-150 features and functions include:

- Precise excitation control for synchronous generator or synchronous motor applications
 - Power factor and var metering values will be opposite in motor mode
- Four excitation control modes:
 - Automatic Voltage Regulation (AVR)
 - Field Current Regulation (FCR)
 - Power Factor Regulation (PF)
 - Var Regulation (var)
- Three pre-position setpoints for each excitation control mode
- Internal tracking between operating mode setpoints and optional external tracking of a second DECS excitation setpoint
- Two PID stability groups with Auto Tune feature
- Remote setpoint control input accepts analog voltage or current control signal
- Grid code functions
 - Connect and disconnect
 - Active power control
 - Reactive power control
- Optional network load sharing
- Real-time metering
- Optional integrated power system stabilizer (PSS)
 - Generator or motor control modes, accommodates phase rotation changes between modes
 - Speed and power sensing or speed-only sensing
- Soft start and voltage buildup control
- Load Shed Control
- Four limiting functions:
 - Overexcitation: summing point and takeover
 - Underexcitation
 - Stator current
 - Underfrequency
- Seventeen protection functions:
 - Machine undervoltage (27)
 - Machine overvoltage (59)

- Loss of sensing (LOS)
- Overfrequency (81O)
- Underfrequency (81U)
- Field overvoltage
- Exciter diode failure
- Sync-check (25)
- Eight configurable protection elements
- Eight programmable contact-sensing inputs
- Three contact outputs
 - One, fixed-function output: Watchdog (SPDT configuration)
 - Two programmable outputs
- Flexible communication
 - Serial communication through optional front- or rear-panel USB port
 - Optional CAN communication for external setpoint tracking
 - Optional Modbus® communication through Modbus TCP
 - Ethernet communication through an RJ-45 port
- Data logging and sequence of events
- USB powered for programming via BESTCOMS*Plus* software

Package

A single, compact package contains all excitation control and power components.

The front panel provides local annunciation through light-emitting diodes (LEDs). Remote annunciation and control is provided through a flexible communication interface, which accommodates Ethernet and USB.

Optional Features and Capabilities

DECS-150 optional features and capabilities are defined by a style number. The model number and style number describe options and characteristics in a specific device and appear on a label affixed to the device.

Style Number

The style number identification chart in Figure 1-1 defines the electrical characteristics and operational features available in the DECS-150.

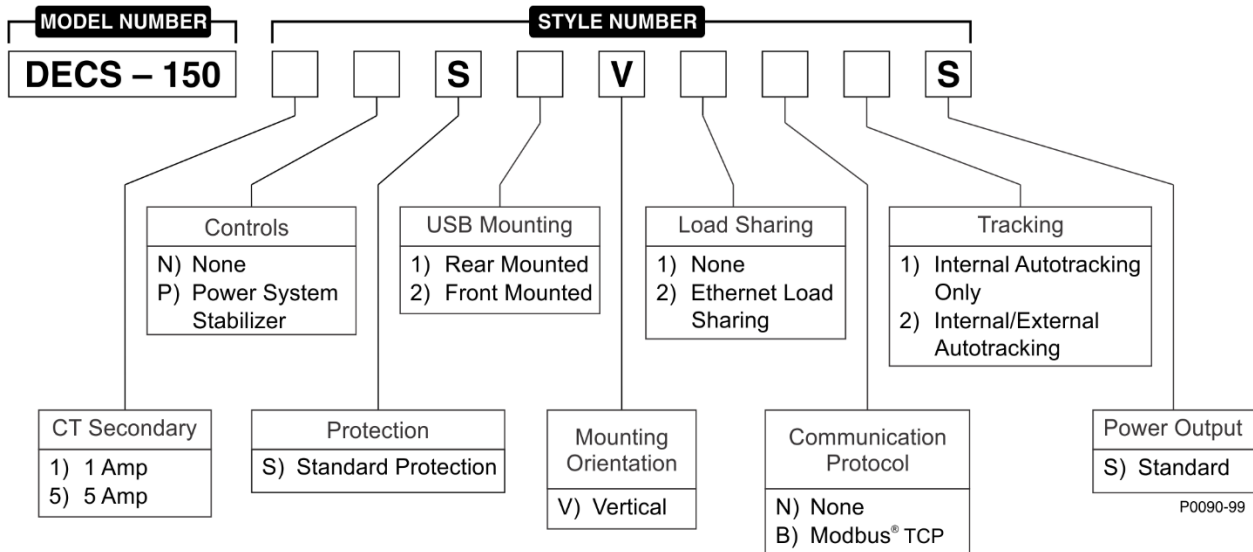


Figure 1-1. DECS-150 Style Chart

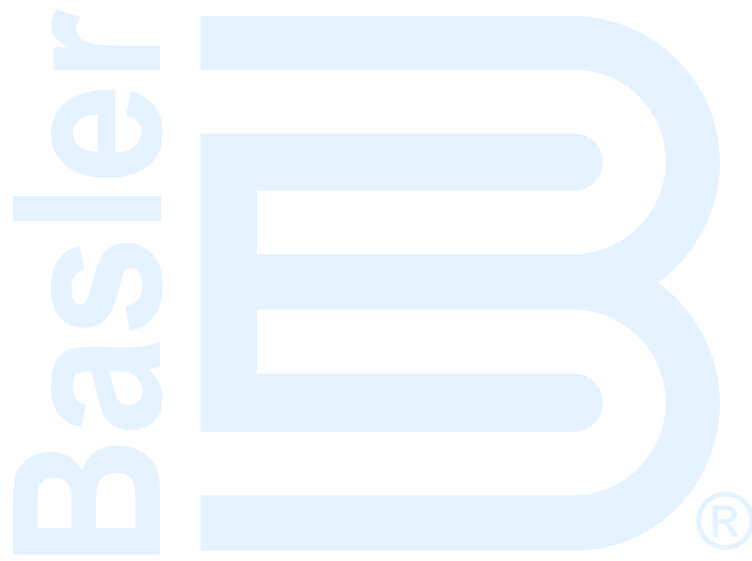
Storage

If a DECS-150 will not be placed in service right away, store it in the original shipping carton in a moisture- and dust-free environment. The temperature of the storage environment must be within the range of -40 to 85°C (-40 to 185°F).

Electrolytic Capacitor Considerations

The DECS-150 contains long-life aluminum electrolytic capacitors. For a DECS-150 kept in storage as a spare, the life of these capacitors can be maximized by energizing the device for 30 minutes once per year. Refer to the energizing procedures provided in the *Maintenance* section.

When energizing the DECS-150 from a low impedance source (such as a wall outlet), use of an Inrush Current Reduction Module (ICRM) is recommended to prevent damage to the DECS-150. For a detailed description of the Inrush Current Reduction Module, refer to Basler publication 9387900990. ICRM connections are illustrated in the *Typical Connections* section.



2 • Front Panel

The DECS-150 front panel consists of 11 status LEDs. A USB port may be mounted on the front or rear panel of the DECS-150. Refer to the USB Mounting Option in the style chart in the *Introduction* section.

Front Panel Illustration and Description

DECS-150 indicators are illustrated in Figure 2-1 and described in Table 2-1.

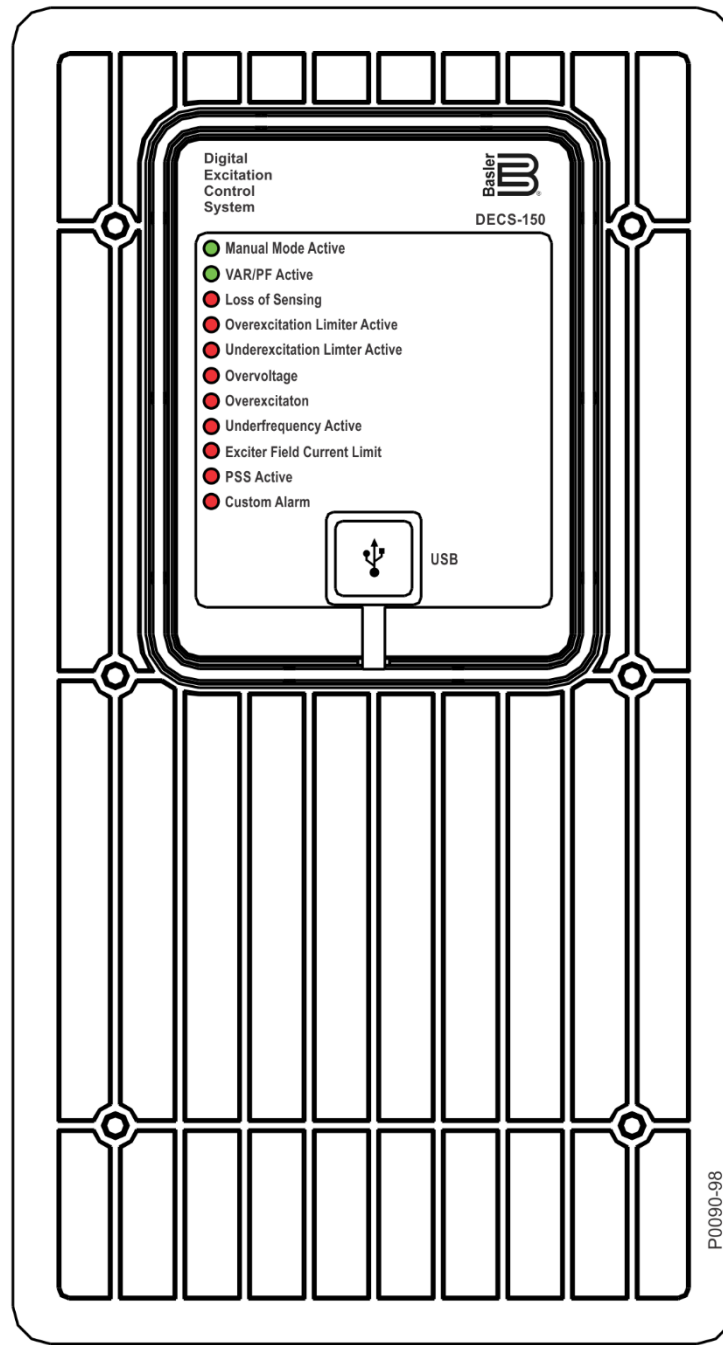


Figure 2-1. Front Panel Indicators

Table 2-1. Front Panel Indicators Descriptions

LED Name	LED Description
Manual Mode Active	This green LED lights when the DECS-150 is operating in Manual (FCR) mode. Manual mode is enabled through BESTCOMSPPlus® software.
VAR/PF Active	This green LED lights when the DECS-150 is operating in either var or power factor mode. Var/power factor control is enabled through BESTCOMSPPlus software. By default logic, Contact Input 7 (52 J/K) disables var/power factor control. An open contact enables the DECS-150 to control the machine reactive power in either the var or power factor mode. The contact has no effect when this function is not enabled in BESTCOMSPPlus.
Loss of Sensing	This red LED lights when a loss of machine sensing voltage is detected. In BESTlogic™ Plus, status inputs can be connected to other logic elements and to a physical relay output to annunciate the condition and to initiate corrective action. Depending on the protective action selected, the DECS-150 will either shut down or transfer to Manual mode. The Loss of Sensing LED will light for five seconds when the DECS-150 is powered up following a loss of sensing shutdown.
Overexcitation Limiter Active	This red LED lights when the field current exceeds the programmed overexcitation limit. It stays lit until the overexcitation condition ceases or the overexcitation time delay expires and the DECS-150 shuts down. The Overexcitation Limiter Active LED will light for five seconds when the DECS-150 is powered up following an overexcitation limiting shutdown.
Underexcitation Limiter Active	This red LED lights when the sensed, reactive power (leading vars) decreases below the programmed underexcitation limit. It stays lit until the underexcitation condition ceases or the underexcitation time delay expires and the DECS-150 shuts down. The Underexcitation Limiter Active LED will light for five seconds when the DECS-150 is powered up following an underexcitation limiting shutdown.
Overvoltage	This red LED lights when machine output voltage exceeds the adjustable setpoint for the duration of the adjustable time delay. The DECS-150 shuts down (if hardware shutdown is enabled). In BESTlogicPlus, status inputs can be connected to other logic elements and to a physical relay output to annunciate the condition and to initiate corrective action. The Overvoltage LED will light for five seconds when the DECS-150 is powered up following an overvoltage shutdown.
Overexcitation	This red LED flashes when the field voltage exceeds the field overvoltage pickup threshold for the duration of the time delay. After the time delay expires, this red LED will light continuously and the DECS-150 will shut down. The Overexcitation LED will light for five seconds when the DECS-150 is powered up following an overexcitation shutdown.
Underfrequency Active	This red LED lights when the machine frequency decreases below the underfrequency setpoint and the DECS-150 is regulating on the selected volts per hertz curve.
Exciter Field Current Limit	This red LED lights when the field current is too high, which could result in damage to the regulator. This condition also shuts down excitation. A restart is required to begin regulating again.
PSS Active	This red LED lights when the optional integrated power system stabilizer (PSS) is enabled and can generate a stabilizing signal in response to power system disturbances.
Custom Alarm	This red LED lights when the Set input of the CUSTOM_LED logic element is true. Refer to the BESTlogicPlus section for more information.

USB Port

This type B USB jack connects the DECS-150 with a PC operating BESTCOMSP*lus* for local communication. BESTCOMSP*lus* is supplied with the DECS-150.

Caution

In accordance with the guidelines defined in USB standards, the USB port on this device is not isolated. To prevent damage to a connected PC or laptop, the DECS-150 must be properly tied to ground.



3 • Power Input and Output

Power Input

The DECS-150 uses the operating power input as the source for the converted excitation power that it applies to the field.

Note

The DECS-150 does not provide galvanic isolation between the operating power input and ground.

Operating Power

Power input terminals are labeled 3, 4, 5, and GND. Single-phase or three-phase power may be applied. When connecting single-phase operating power, use terminals 3 and 5 since the DECS-150 monitors the level of operating power through these terminals.

The DECS-150 can be powered directly from a variety of sources as long as the DECS-150 input power specifications are followed (see the *Specifications* section).

Examples of DECS-150 operating power sources are:

- Machine (shunt fed)
- Permanent magnet generator (PMG)
- Auxiliary winding

To achieve the desired level of excitation, the appropriate operating power input voltage must be applied. Table 3-1 lists the acceptable operating power voltage ranges for the DECS-150. The operating power frequency range for the DECS-150 is 50 to 500 hertz for all voltages.

Table 3-1. DECS-150 Operating Power Specifications

Desired Nominal Excitation Power Voltage	Applied Operating Power Voltage Range
63 Vdc	100 to 139 Vac, or 125 Vdc
125 Vdc	190 to 277 Vac, or 250 Vdc

Inrush Current Reduction Module (ICRM)

During DECS-150 power-up, the optional ICRM prevents damage to the DECS-150 by limiting inrush current to a safe level. When operating power is applied to the DECS-150, the ICRM limits the inrush current by adding a high level of resistance between the DECS-150 and the power source. Once the inrush current subsides, the series resistance diminishes quickly to allow nominal, steady-state current flow.

Caution

To prevent damage to the DECS-150, the use of the ICRM is recommended when using a low impedance source, such as a wall outlet.

For a detailed description of the Inrush Current Reduction Module, refer to Basler publication 9387900990. ICRM connections are illustrated in the *Typical Connections* section.

Power Output

The power output supplies regulated dc excitation power to the field of a brushless exciter. Excitation power is supplied at terminals F+ and F-.

Note
The DECS-150 does not provide galvanic isolation between the field output and ground.

The DECS-150 power output supplies excitation power by means of a filtered, switching power module that uses pulse-width modulation. It is capable of supplying 7 Adc (70°C ambient) continuously or 10 Adc (55°C ambient) continuously at nominal voltages of 63 or 125 Vdc. With nominal operating voltage applied, it has a forcing capability of 11 Adc for 10 seconds (70°C ambient) or 14 Adc for 10 seconds (55°C ambient).

4 • Voltage and Current Sensing

The DECS-150 senses machine voltage, machine current, and bus voltage through dedicated, isolated inputs.

Machine Voltage

Three-phase machine sensing voltage is applied to DECS-150 terminals E1, E2, and E3. This sensing voltage is typically applied through a user-supplied voltage transformer, but may be applied directly. These terminals accept three-phase, three-wire connections at terminals E1 (A), E2 (B), and E3 (C) or single-phase connections at E1 (A) and E3 (C).

The machine voltage sensing input accepts a maximum voltage of 600 Vac and has a burden of less than 1 VA.

The transformer primary and secondary winding voltages are entered in settings that the DECS-150 uses to interpret the applied sensing voltage and calculate system parameters. The phase rotation of the machine sensing voltage can be configured as ABC or ACB. Information about configuring the DECS-150 for the machine sensing voltage is provided in the *Configuration* section.

Typical machine voltage sensing connections are illustrated in Figure 4-1.

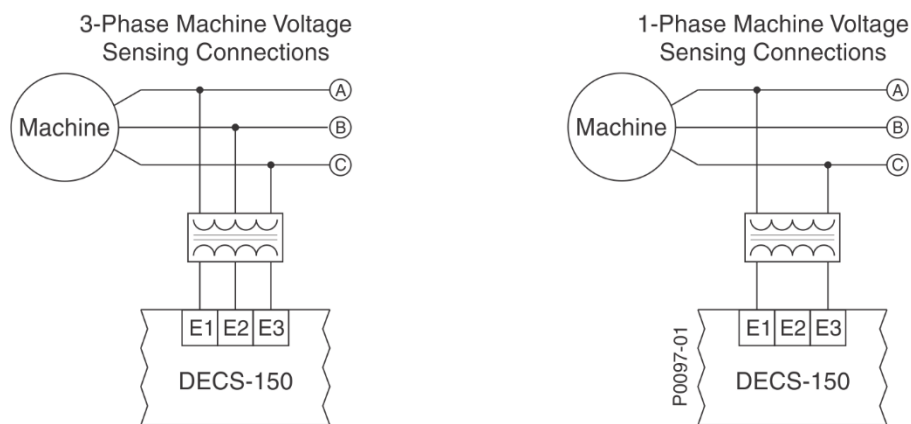


Figure 4-1. Typical Machine Voltage Sensing Connections

Machine Current

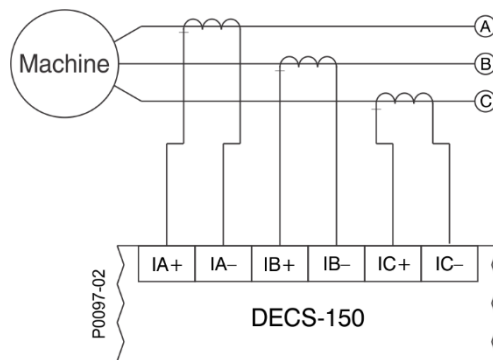
Machine current sensing inputs consist of three phase-sensing inputs and a sensing input for cross-current compensation.

Note

Current transformer (CT) grounding should be applied in accordance with local codes and conventions.

Phase Sensing

Three-phase machine sensing current is applied to DECS-150 terminals IA+ and IA–, IB+ and IB–, and IC+ and IC– through user-supplied current transformers (CTs). Single-phase machine sensing current is applied to DECS-150 terminals IB+ and IB–. The DECS-150 is compatible with CTs having 5 Aac or 1 Aac nominal secondary ratings. The DECS-150 uses this secondary rating, along with the CT nominal primary ratings to interpret the sensed current and calculate system parameters. Information about configuring the DECS-150 for the machine sensing voltage is provided in the *Configuration* section of this manual. Typical machine phase-current sensing connections are shown in Figure 4-2.

**NOTES**

1. If only one CT is used, connect it to B-phase.
2. Three-phase current sensing is required for PSS applications.

Figure 4-2. Typical Machine Current Sensing Connections

Cross-Current Compensation

Cross-current compensation (reactive differential) mode allows two or more paralleled generators to share a common reactive load. As shown in Figure 4-3, each generator is controlled by a DECS-150 using the DECS-150 cross-current compensation input (terminals CC+ and CC-) and a dedicated, external current transformer (CT) to sense generator current. The resistors shown in Figure 4-3 are used to set the burden and may be adjusted to suit the application. Ensure that the power rating of the resistors is adequate for the application.

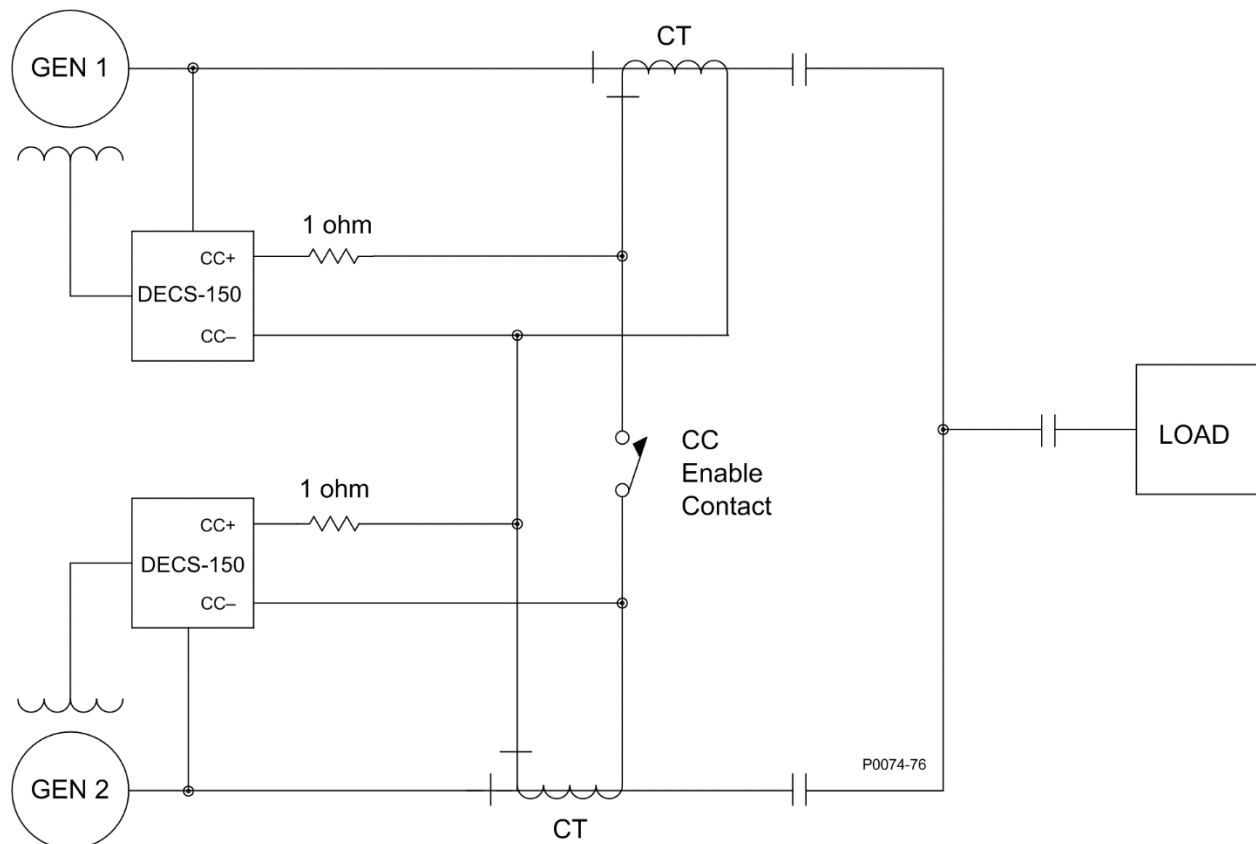


Figure 4-3. Connections for Cross-Current Compensation

Note

If a machine is taken offline, then the secondary winding of that machine's cross-current compensation CT must be shorted. Otherwise, the cross-current compensation scheme will not function.

Bus Voltage

Bus voltage monitoring enables bus failure detection and a 25 sync-check element, along with machine and bus voltage matching. Three-phase bus sensing voltage is applied to DECS-150 terminals B1, B2, and B3. This sensing voltage is typically applied through a user-supplied voltage transformer, but may be applied directly. These terminals accept three-phase, three-wire connections at terminals B1 (A), B2 (B), and B3 (C) or single-phase connections at B3 (C) and B1 (A).

The bus voltage sensing input accepts a maximum voltage of 600 Vac and has a burden of less than 1 VA.

The transformer primary and secondary winding voltages are entered in settings that the DECS-150 uses to interpret the applied sensing voltage. Information about configuring the DECS-150 for the bus sensing voltage is provided in the *Configuration* section of this manual.

Typical bus voltage sensing connections are illustrated in Figure 4-4.

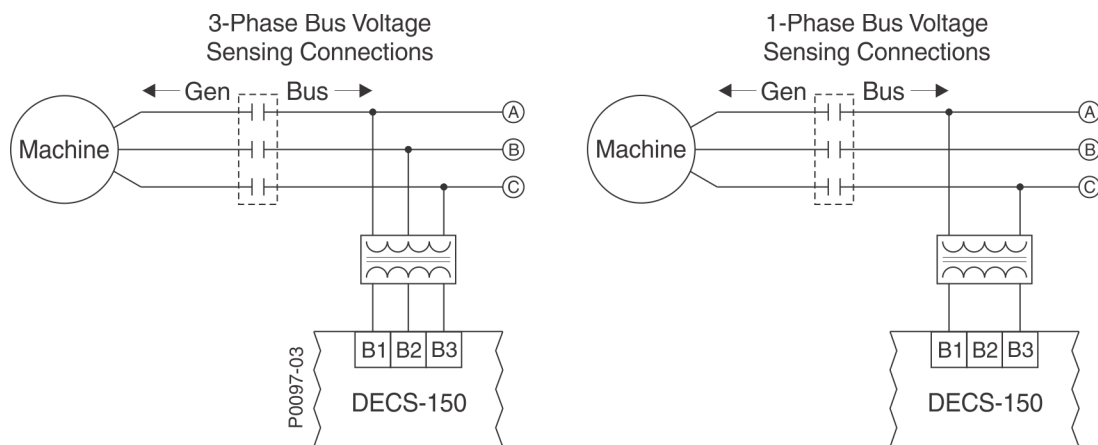


Figure 4-4. Typical Bus Voltage Sensing Connections



5 • Regulation

The DECS-150 precisely regulates the level of supplied excitation power in each of the four available regulation modes. Stable regulation is enhanced by the automatic tracking of the active-mode setpoint by the inactive regulation modes. Pre-position setpoints within each regulation mode enable the DECS-150 to be configured for multiple system and application needs.

Operating Modes

BESTCOMSPlus Navigation Path: Settings Explorer, Operating Settings, Operating Mode

DECS-150 control of a synchronous generator or synchronous motor is possible through selection of the appropriate operating mode. Operating mode settings are shown in Figure 5-1.

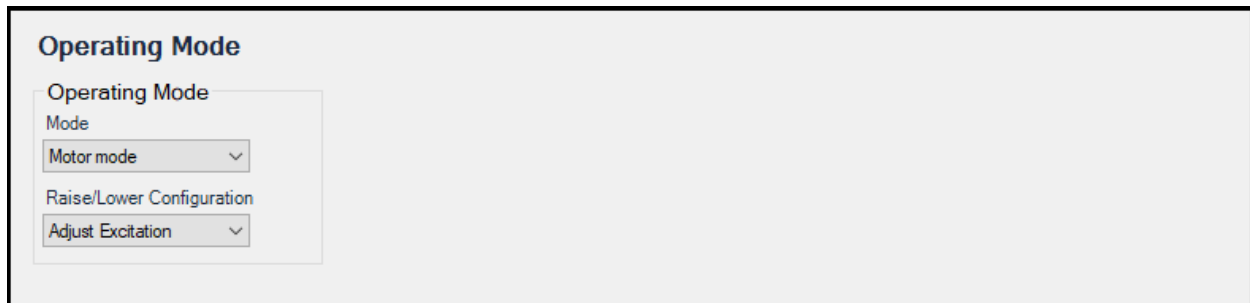


Figure 5-1. Operating Mode Settings

When Motor mode is selected, the DECS-150 views the controlled machine as a load, and all appropriate fields on the front panel HMI and in BESTCOMSPlus are switched from “Generator” to “Motor.” Line current angles are shifted 180°, causing the sign of real and reactive power measurements to be reversed in all metering, data logs, and real-time analysis fields.

Selecting Motor mode enables the Raise/Lower Configuration setting. This setting configures whether raise and lower inputs adjust the excitation level or the regulation setpoint.

Regulation Modes

BESTCOMSPlus Navigation Path: Settings Explorer, Operating Settings, AVR/FCR and VAR/PF

The DECS-150 provides four regulation modes: Automatic Voltage Regulation (AVR), Field Current Regulation (FCR), var, and Power Factor (PF).

AVR

When operating in AVR (Automatic Voltage Regulation) mode, the DECS-150 regulates the excitation level in order to maintain the generator terminal voltage setpoint despite changes in load and operating conditions. AVR setpoint (or operating point) adjustment is made through any one of the following methods:

- Application of contacts at DECS-150 contact inputs configured for raising and lowering the active setpoint
- Application of an analog control signal at the DECS-150 Auxiliary Control input.
- The BESTCOMSPlus Control Panel screen (available in the BESTCOMSPlus® Metering Explorer)
- A raise or lower command transmitted through the DECS-150 Modbus port.

The range of adjustment is defined by Minimum and Maximum settings that are expressed as a percentage of the rated generator voltage. The length of time required to adjust the AVR setpoint from one limit to the other is controlled by a Traverse Rate setting.

Settings that are related to machine ratings can be set in either actual units of voltage or in per unit values. When a native unit is edited, BESTCOMSP^{Plus} automatically recalculates the per unit value based on the native unit setting and the rated data parameter (on the System Parameters, Rated Data screen) associated with it. When a per unit value is edited, BESTCOMSP^{Plus} automatically recalculates the native value based on the per unit setting and the rated data parameter associated with it.

Once all per unit values are assigned, if the rated data parameters are changed, BESTCOMSP^{Plus} automatically recalculates all native unit settings based on the modified rated data parameters.

The AVR setpoint has a native unit of Primary Volts and the rated data associated with it is Machine Rated Data, Voltage (on the System Parameters, Rated Data screen).

The AVR/FCR Setpoints screen is illustrated in Figure 5-2.

FCR

When operating in FCR (Field Current Regulation) mode, the DECS-150 regulates the level of current it supplies to the field based on the FCR setpoint. The setting range of the FCR setpoint depends on the field rated data and other associated settings. FCR setpoint adjustment is made through any one of the following methods:

- Application of contacts at DECS-150 contact inputs configured for raising and lowering the active setpoint
- Application of an analog control signal at the DECS-150 Auxiliary Control input
- The BESTCOMSP^{Plus}® Control Panel screen (available in the BESTCOMSP^{Plus} Metering Explorer)
- A raise or lower command transmitted through the DECS-150 Modbus port.

The range of adjustment is defined by Minimum and Maximum settings that are expressed as a percentage of the rated field current. The length of time required to adjust the FCR setpoint from one limit to the other is controlled by a Traverse Rate setting.

Settings that are related to machine ratings can be set either in actual units or in per unit values. When a native unit is edited, BESTCOMSP^{Plus} automatically recalculates the per unit value based on the native unit setting and the rated data parameter (on the System Parameters, Rated Data screen) associated with it. When a per unit value is edited, BESTCOMSP^{Plus} automatically recalculates the native value based on the per unit setting and the rated data parameter associated with it.

Once all per unit values are assigned, if the rated data parameters are changed, BESTCOMSP^{Plus} automatically recalculates all native unit settings based on the modified rated data parameters.

The FCR setpoint has a native unit of Primary Amps and the rated data associated with it is Field Rated Data, Current (on the System Parameters, Rated Data screen).

The AVR/FCR Setpoints screen is illustrated in Figure 5-2.

Automatic Voltage Regulator (AVR)		Field Current Regulator (FCR)	
Setpoint		Setpoint	
120.0	Primary V	0.1	Primary A
1.000	Per Unit	0.020	Per Unit
Min (% of rated)		Min (% of rated)	
70.0		0.0	
Max (% of rated)		Max (% of rated)	
120.0		120.0	
Traverse Rate (s)		Traverse Rate (s)	
20		20	
Pre-position 1		Pre-position 1	

Figure 5-2. AVR/FCR Setpoints

Var

When operating in var mode, the DECS-150 regulates the reactive power (var) output of the machine based on the var setpoint. The setting range of the var setpoint depends on the machine ratings and other associated settings. Var setpoint adjustment is made through any one of the following methods:

- Application of contacts at DECS-150 contact inputs configured for raising and lowering the active setpoint
- Application of an analog control signal at the DECS-150 Auxiliary Control input
- The BESTCOMSP*lus* Control Panel screen (available in the BESTCOMSP*lus* Metering Explorer)
- A raise or lower command transmitted through the DECS-150 Modbus port.

The range of adjustment is defined by Minimum and Maximum settings that are expressed as a percentage of the machine rated kVA output. The length of time required to adjust the Var setpoint from one limit to the other is controlled by a Traverse Rate setting. A Fine Voltage Adjustment Band setting defines the upper and lower boundaries of voltage correction when operating in var or power factor regulation modes.

Settings that are related to machine ratings can be set in either actual units of voltage or in per unit values. When a native unit is edited, BESTCOMSP*lus* automatically recalculates the per unit value based on the native unit setting and the rated data parameter (on the System Parameters, Rated Data screen) associated with it. When a per unit value is edited, BESTCOMSP*lus* automatically recalculates the native value based on the per unit setting and the rated data parameter associated with it.

Once all per unit values are assigned, if the rated data parameters are changed, BESTCOMSP*lus* automatically recalculates all native unit settings based on the modified rated data parameters.

The Reactive Power Control setpoint has a native unit of Primary kvar and the rated data associated with it is Machine Rated Data, Rating (kVA) (on the System Parameters, Rated Data screen).

The var/PF Setpoints screen is illustrated in Figure 5-3.

Power Factor

When operating in Power Factor (PF) mode, the DECS-150 controls the var output of the machine to maintain the Power Factor setpoint as the kW load on the machine varies. The setting range of the PF setpoint is determined by the PF – Leading and PF – Lagging settings. The length of time required to adjust the PF setpoint from one limit to the other is controlled by a Traverse Rate setting. A Fine Voltage Adjustment Band setting defines the upper and lower boundaries of voltage correction when the DECS-150 is operating in var or Power Factor regulation modes. PF Active Power Level establishes the level of machine output power (kW) where the DECS-150 switches to/from Droop Compensation/Power Factor mode. If the level of power decreases below the setting, the DECS-150 switches from Power Factor mode to Droop Compensation mode. Conversely, as the level of power increases above the setting, the DECS-150 switches from Droop Compensation mode to Power Factor mode. A setting of 0 to 30% may be entered in 0.1% increments.

The var/PF Setpoints screen is illustrated in Figure 5-3.

Section	Parameter	Value	Unit
Fine Voltage Adjustment Band	Fine Voltage Adjustment Band (%)	20.00	
	PF Active Power Level	0.0	
Reactive Power Control (var)	Setpoint	0.00	Primary kvar
		0.000	Per Unit
	Min (% of rated)	0.0	
	Max (% of rated)	100.0	
	Traverse Rate (s)	20	
Power Factor Control (PF)	Setpoint	1.00	
	PF - Leading	-0.80	
	PF - Lagging	0.80	
	Traverse Rate (s)	20	
	Pre-position 1		

Figure 5-3. Var/PF Setpoints

Pre-Position Setpoints

Each regulation mode has three pre-position setpoints that allow the DECS-150 to be configured for multiple system and application needs. Each pre-position setpoint can be assigned to a programmable contact input. When the appropriate contact input is closed, the setpoint is driven to the corresponding pre-position value.

Each pre-position function has three settings: Setpoint, Traverse Rate, and Mode. The setting range of each pre-position setpoint is identical to that of the corresponding control mode setpoint. The length of time required to adjust from one pre-position setpoint to another is controlled by the Traverse Rate setting. A setting of zero (0) implements an instantaneous step.

Mode

The Mode setting determines whether or not the DECS-150 will respond to further setpoint change commands while the pre-position command is being asserted.

If the pre-position mode is Release, setpoint change commands are accepted to raise and lower the setpoint while the pre-position command is being asserted. Additionally, if the inactive pre-position mode is Release and internal tracking is enabled, the pre-position value will respond to the tracking function.

If the pre-position mode is Maintain, further setpoint change commands will be ignored or granted based on priority while the appropriate contact input is closed. Pre-position 3 has the highest priority and pre-position 1 has the lowest priority. For example, if pre-position 1 (maintaining) is active and pre-position 3 closes, the setpoint will change to pre-position 3. However, if pre-position 2 (maintaining) is active and pre-position 1 closes, the setpoint will not change because pre-position 2 is a higher priority than pre-position 1. Additionally, if the inactive pre-position mode is Maintain and internal tracking is enabled, the inactive mode will maintain the inactive setpoint at the pre-position value and override the tracking function.

A portion of the pre-position setpoints for var and PF modes are illustrated in Figure 5-4. (Pre-Position Setpoints for AVR and FCR modes are similar and not shown here.)

Figure 5-4. Pre-Position Setpoints

Operation with Paralleled Generators

BESTCOMSPi^{us} Navigation Path: Settings Explorer, Operating Settings, Parallel/Line Drop Compensation

The DECS-150 can be used to control the excitation level of two or more generators operating in parallel so that the generators share the reactive load. The DECS-150 can employ either droop compensation or cross-current compensation (reactive differential) schemes for reactive load sharing.

The Parallel/Line Drop Compensation screen is illustrated in Figure 5-5.

Droop Compensation

Droop compensation serves as a method of controlling reactive current when the generator is connected in parallel with another energy source. Droop compensation utilizes the B-phase CT. When droop

compensation is enabled, the generator voltage is adjusted in proportion to the measured generator reactive power. The reactive droop compensation setting is expressed as a percentage of the generator rated terminal voltage.

By default logic, closing Contact Input 6 (52 L/M) disables parallel operation. An open contact enables parallel operation and the DECS-150 operates in reactive droop compensation mode.

Note

For droop compensation to operate, the PARALLEL_EN_LM logic block must be set true in BESTlogicPlus programmable logic.

Line Drop Compensation

When enabled, line drop compensation can be used to maintain voltage at a load located at a distance from the generator. The DECS-150 achieves this by measuring the line current and calculating the voltage for a specific point on the line. Line drop compensation is applied to both the real and reactive portion of the generator line current. It is expressed as a percentage of the generator terminal voltage.

Equation 5-1 is used to calculate the Line Drop Value.

$$LD_{Value} = \sqrt{\left(V_{avg} - \left[LD \times I_{avg} \times \cos(I_{bang})\right]\right)^2 + \left(LD \times I_{avg} \times \sin(I_{bang})\right)^2}$$

Equation 5-1. Line Drop Value

- LD_{Value} = Line drop value (per unit)
- V_{avg} = Average voltage, metered value (per unit)
- LD = Line Drop % / 100
- I_{avg} = Average Current, metered value (per unit)
- I_{bang} = Angle of phase B current (no compensation)

The LD_{Value} is the per-unit value seen down the line from the generator. Equation 5-2 is used to determine the voltage needed to adjust for line drop.

$$V_{adjust,PU} = V_{rms,PU} - LD_{Value}$$

Equation 5-2. Voltage Needed to Adjust for Line Drop

Equation 5-3 is used to obtain primary units.

$$V_{adjust} = V_{adjust,PU} \times V_{rated}$$

Equation 5-3. Obtain Primary Units

The new line drop adjusted setpoint is calculated using Equation 5-4.

$$V_{Adjusted\ Setpoint} = V_{Setpoint} + V_{adjust}$$

Equation 5-4. Line Drop Adjusted Setpoint

Cross-Current Compensation

Cross-current compensation (reactive differential) mode serves as a method of connecting multiple generators in parallel to share reactive load. When reactive load is shared properly, no current is fed into the DECS-150 cross-current compensation input (terminals IB+ and IB-). Improper sharing of reactive load causes a differential current to be fed into the cross-current compensation input. When cross-current compensation is enabled, this input causes the DECS-150 to respond with the proper level of regulation. The response of the DECS-150 is controlled by the cross-current compensation gain setting which is expressed as a percentage of the system nominal CT setting.

Application information about cross-current compensation is available in the *Voltage and Current* section of this manual.

Network Load Sharing

In a multiple-generator application, the load sharing function ensures equal generator reactive-power sharing. It operates in a similar manner to cross-current compensation but without the external hardware requirements and distance limitations. Instead of sharing load based on the CT ratio, load is shared on a per-unit basis calculated from the generator rated data. Sharing of load information between DECS-150 controllers is accomplished through the Ethernet port of each DECS-150 communicating over a peer-to-peer network dedicated for the load sharing function. Each DECS-150 measures the reactive current of its associated generator and broadcasts its measurement to all other DECS-150 controllers on the network. Each DECS-150 compares its level of reactive current to the sum of all measured currents and adjusts its excitation level accordingly.

When the unit's configuration does not match the configuration of the other units with load sharing enabled, the Network Load Share Config Mismatch logic element becomes true. The Configuration Mismatch Delay setting adds a delay before the element becomes true.

A Load Share ID setting identifies the DECS-150 as a load sharing unit in the network. Checking a Load Sharing Unit number box allows any DECS-150 load sharing units on the network with that Load Share ID number to share load with the currently connected DECS-150. It is not necessary for the Load Share ID to be unique for each unit. This allows for load sharing units to be grouped.

Load sharing settings consist of an Enable checkbox and Droop, Kg, Ki, Max Vc, Configuration Mismatch Delay, and Load Share ID settings.

Parallel/Line Drop Compensation

Droop Compensation

Enable

Reactive Droop Compensation (% of rated)

5.0

Line Drop Compensation

Enable

Line Drop Compensation (% of rated)

5.0

Cross Current Compensation

Enable

Cross Current Compensation Gain (% of rated)

0.00

Network Load Share

Enable

Droop (%)

0.0

Kg

0.00

Ki

0.00

Max Vc

0.00

Configuration Mismatch Delay (s)

0.5

Load Share ID

1

<input checked="" type="checkbox"/> Load Sharing Unit 1	<input checked="" type="checkbox"/> Load Sharing Unit 9
<input checked="" type="checkbox"/> Load Sharing Unit 2	<input checked="" type="checkbox"/> Load Sharing Unit 10
<input checked="" type="checkbox"/> Load Sharing Unit 3	<input checked="" type="checkbox"/> Load Sharing Unit 11
<input checked="" type="checkbox"/> Load Sharing Unit 4	<input checked="" type="checkbox"/> Load Sharing Unit 12
<input checked="" type="checkbox"/> Load Sharing Unit 5	<input checked="" type="checkbox"/> Load Sharing Unit 13
<input checked="" type="checkbox"/> Load Sharing Unit 6	<input checked="" type="checkbox"/> Load Sharing Unit 14
<input checked="" type="checkbox"/> Load Sharing Unit 7	<input checked="" type="checkbox"/> Load Sharing Unit 15
<input checked="" type="checkbox"/> Load Sharing Unit 8	<input checked="" type="checkbox"/> Load Sharing Unit 16

Figure 5-5. Parallel/Line Drop Compensation Settings

Autotracking

BESTCOMSPlus Navigation Path: Settings Explorer, Operating Settings, Autotracking

Internal regulation mode setpoint tracking is a standard feature on the DECS-150. External setpoint tracking is optional (style xxxxxx2). The Auto Tracking screen is illustrated in Figure 5-6.

Internal Setpoint Tracking

In applications using a single DECS-150, internal tracking can be enabled so that the inactive regulation modes track the active regulation mode.

The following examples demonstrate the advantages of internal tracking:

- If the excitation system is operating online with internal tracking enabled, a loss of sensing condition could trigger a transfer to FCR mode. Autotracking minimizes the impact that a loss of sensing condition has on the exciter's ability to maintain the proper excitation level.
- While performing routine testing of the DECS-150 in backup mode, the internal tracking feature allows a transfer to an inactive mode that will result in no disturbance to the system.

Two parameters control the behavior of internal tracking. The Delay setting determines the time delay between a large system disturbance and the start of setpoint tracking. The Traverse Rate setting configures the length of time for the inactive mode setpoints to traverse the full setting range of the active mode setpoint.

External Setpoint Tracking

For critical applications, a second DECS-150 can provide backup excitation control. The DECS-150 (style xxxxxx2) allows for excitation redundancy by providing external tracking and transfer provisions between DECS-150 controllers. The secondary DECS-150 can be configured to track the primary DECS-150 setpoint. Proper redundant excitation system design allows for removal of the failed system.

Like internal tracking, external setpoint tracking uses enable/disable, delay, and traverse rate settings.

Tracking Comms Loss Alarm

An alarm can be configured to annunciate when the DECS-150 is configured as the secondary DECS-150 and has lost tracking communications from the primary DECS-150.

Note
Periodic testing of the backup system must be performed to ensure that it is operational and can be placed in service without warning.

Figure 5-6. Autotracking Settings

Setpoint Configure

BESTCOMSPi+ Navigation Path: Settings Explorer, Operating Settings, Setpoint Configure

When the Auto Save setting is enabled, the DECS-150 automatically saves the active, externally driven, raise/lower, pre-position, and tracking setpoints in ten-minute intervals. Otherwise, the setpoint which was last sent to the DECS-150 via BESTCOMSPi+ is retained. The Setpoint Configure screen is illustrated in Figure 5-7.

Figure 5-7. Setpoint Configure

Voltage Matching

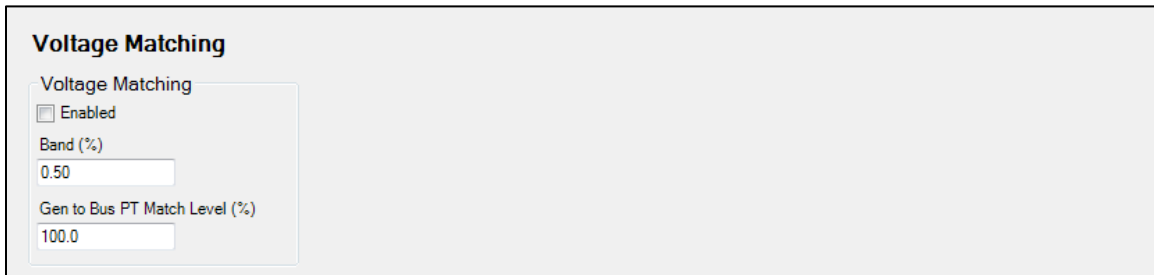
BESTCOMSPi+ Navigation Path: Settings Explorer, Voltage Matching, Voltage Matching

When enabled, voltage matching is active in AVR control mode and automatically adjusts the AVR mode setpoint to match the sensed bus voltage. Voltage matching is based on two parameters: band and matching level.

The voltage matching band setting defines how close in magnitude generator and bus voltage must be to each other for voltage matching to be active. The band level setting is a percentage of rated generator voltage.

The Gen/Motor to Bus PT Match Level setting is provided to compensate for step-up or step-down transformers in the system. The DECS-150 adjusts the sensed machine voltage by this percentage.

The Voltage Matching screen is illustrated in Figure 5-8.



Voltage Matching

Voltage Matching

Enabled

Band (%)

0.50

Gen to Bus PT Match Level (%)

100.0

Figure 5-8. Voltage Matching Settings

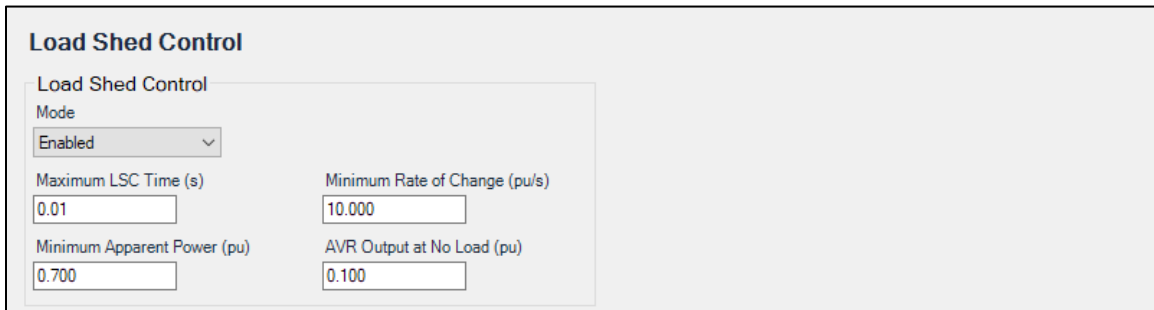
Load Shed Control

When enabled, Load Shed Control (LSC) addresses synchronous generators that exhibit a sudden voltage “dip” then “overshoot” immediately after load shedding. The LSC function bypasses the normal PID controller in the AVR to provide the proper control action for these types of machines.

LSC is enabled when the apparent power (VA) is greater than the Minimum Apparent Power setting. The LSC function calculates the rate of change of apparent power during a load shed event. If the Minimum Rate of Change setting is exceeded, the AVR’s output is forced to zero for the Maximum LSC Time. After the LSC time expires, the output of the AVR’s PID elements are reinitialized to set the AVR output to an adjustable “no load” level (AVR Output at No Load). The LSC function is only active when the rate of change of apparent power is negative (load shed). LSC does not affect the AVR function if LSC is disabled. LSC is disabled if the genset is connected to the grid as determined by the PF_VAR_ENABLE_JK logic block in BESTCOMSP^{Plus}. LSC is only enabled for the AVR mode when terminal voltage is greater than 0.7 pu.

The Load Shed Control State in metering represents the operational status of the LSC function with state 0: disabled, state 1: enabled, state 2: LSC armed, state 3: LSC active, and state 4: LSC in reset delay period of 2 seconds before re-enabling the LSC function.

The Load Shed Control screen is illustrated in Figure 5-9.



Load Shed Control

Load Shed Control

Mode

Enabled

Maximum LSC Time (s)

0.01

Minimum Rate of Change (pu/s)

10.000

Minimum Apparent Power (pu)

0.700

AVR Output at No Load (pu)

0.100

Figure 5-9. Load Shed Control Settings



6 • Auxiliary Control

BESTCOMSPPlus Navigation Path: Settings Explorer, Operating Settings, Auxiliary Input

The DECS-150 accepts an external analog control signal for auxiliary control of the regulation setpoint. Auxiliary setpoint control is possible in all regulation modes: AVR, PF, Var, and FCR. The control signal can also be used for power system stabilizer control.

The Auxiliary Input screen is illustrated in Figure 6-1.

Figure 6-1. Auxiliary Input Screen

Auxiliary Control Input Type

Either a voltage or current control signal may be used for auxiliary control. Terminals I+ and I– accept a 4 to 20 mAdc signal. Terminals V+ and V– accept a –10 to +10 Vdc signal. The input type is selected in BESTCOMSPPlus®.

Auxiliary Control Input Function

The analog control input can be used for auxiliary control of the regulation setpoint, as a power system stabilizer test input, or for grid code input.

When using a current auxiliary control input, the DECS-150 responds to out-of-range inputs in the following ways. If the applied signal decreases below 2 mAdc, the DECS-150 assumes the bias signal has been lost and reverts to an unbiased state. An applied current that exceeds 20 mAdc is interpreted as full bias.

PSS Test Input

The auxiliary control input can be used for control of the optional power system stabilizer function during testing and validation. More information is provided in the *Power System Stabilizer* section.

Grid Code Input

The grid code input must be selected when it is desired to use the auxiliary input as the adjustment source for active and reactive power control.

Setpoint Limits

Minimum and maximum setpoint limits are observed when the With Limit box is checked.

Auxiliary Control Gains

When a current input type is selected, the input current is converted internally by the DECS-150 into a voltage signal in the range of -10 to +10 Vdc. The DECS-150 uses Equation 6-1 when converting the applied current into a voltage.

$$V_{aux} = (I_{aux} - 0.004) \times \left(\frac{20.0}{0.016} \right) - 10.0$$

Equation 6-1. Input Current to Voltage Signal Conversion

Where: V_{aux} is the calculated voltage signal and I_{aux} is the applied current in amperes.

For setpoint control, V_{aux} is multiplied by the appropriate regulation mode auxiliary gain setting.

If the auxiliary input is unused, all auxiliary control gains should be set to zero.

AVR Mode

In AVR mode, the auxiliary control signal is multiplied by the AVR Gain setting. The result defines the setpoint change as a percentage of the rated generator voltage.

$$\text{Generator Voltage Adjust} = V_{aux} \times 0.01 \times \text{AVR Gain} \times \text{Rated Voltage}$$

For example, applying +10 Vdc with an AVR gain of 1.0 raises the AVR setpoint 10% of rated generator voltage. This example also applies to the following modes.

FCR Mode

In FCR mode, the auxiliary control signal is multiplied by the FCR Gain setting. The resulting value relates to a percentage of the rated field current.

$$\text{FCR Adjust} = V_{aux} \times 0.01 \times \text{FCR Gain} \times \text{No Load Rated Field Current}$$

Var Mode

In var mode, the auxiliary control signal is multiplied by the Var Gain setting. The resulting value relates to a percentage of the rated apparent power (kVA).

$$\text{var Adjust} = V_{aux} \times 0.01 \times \text{var Gain} \times 1.7321 \times \text{Rated Voltage} \times \text{Rated Current (Outerloop selected)}$$

Power Factor Mode

In Power Factor mode, the auxiliary control signal is multiplied by the PF Gain setting to define the PF setpoint change.

$$\text{PF Adjust} = V_{aux} \times 0.01 \times \text{PF Gain (Outerloop selected)}$$

Summing Type

The auxiliary control signal can be configured to control the inner or outer regulation control loop. Selecting the inner loop limits auxiliary control to AVR and FCR modes. Selecting the outer loop limits auxiliary control to PF and Var modes.

7 • Contact Inputs and Outputs

Eight internally-wetted, contact-sensing inputs are available for initiating DECS-150 actions. Three sets of output contacts provide annunciation and control.

Contact Inputs

BESTCOMSP^{Plus} Navigation Path: Settings Explorer, Programmable Inputs, Contact Inputs

Eight programmable contact inputs are provided for initiating DECS-150 actions. All inputs have pre-assigned default logic. Refer to the BESTlogic™*Plus* section for contact input assignments.

All contact inputs are compatible with dry relay/switch contacts. Each contact input has an interrogation voltage and current of 12 Vdc at 1.2 mAdc. Appropriate switches/contacts should be selected for operation with this signal level.

Note

The length of wiring connected to each contact input terminal must not exceed 150 feet (45.7 meters). Longer wiring lengths may allow induced electrical noise to interfere with the recognition of contact inputs.

The eight programmable inputs can be connected to monitor the status of excitation system contacts and switches. Then, using BESTlogic^{Plus} programmable logic, these inputs can be used as part of a user-configured logic scheme to control and annunciate a variety of system conditions and contingencies. Information about using the programmable inputs in a logic scheme is provided in the *BESTlogicPlus* section.

Notes

Simultaneously closing the Raise and Lower active setpoint contacts will result in no change to the setpoint.

Simultaneously closing the Auto and Manual mode contacts will result in selection of manual mode.

To make the programmable contact inputs easier to identify, you can assign a custom name (up to 64 alphanumeric characters) that relates to the inputs/functions of your system. Figure 7-1 shows the BESTCOMSP^{Plus}® Contact Inputs screen with the pre-assigned labels shown.

Contact Inputs			
Input #1 Label Text AUTO_MODE	Input #2 Label Text MANUAL_MODE	Input #3 Label Text PREPOSITION_1	Input #4 Label Text RAISE
Input #5 Label Text LOWER	Input #6 Label Text 52 L/M	Input #7 Label Text 52 J/K	Input #8 Label Text VM

Figure 7-1. Contact Input Label Text

See the *Terminals and Connectors* section for an illustration of the programmable input terminals.

Contact Outputs

BESTCOMSPlus Navigation Path: Settings Explorer, Programmable Outputs, Contact Outputs

DECS-150 contact outputs consist of a dedicated watchdog output, two programmable outputs, and a breaker shunt trip output.

Watchdog Output

This SPDT (Form C) output changes state during the following conditions:

- Operating power is lost
- Normal firmware execution ceases
- Transfer Watchdog Trip is asserted in *BESTlogicPlus*

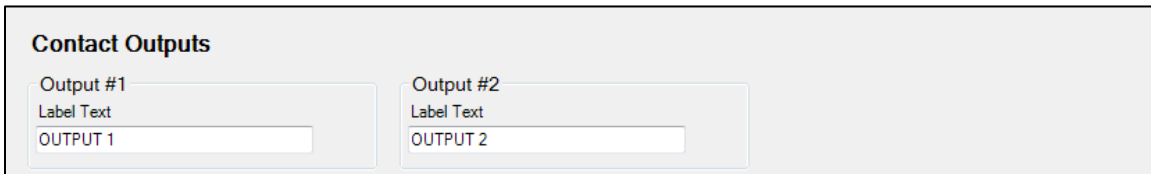
Watchdog output connections are made at terminals WD3 (normally open), WD2 (common), and WD1 (normally closed).

During normal operating conditions, the WD3 contact is closed and the WD1 contact is open.

Programmable Outputs

The two programmable, normally-open contact outputs can be configured to annunciate DECS-150 status, active alarms, active protection functions, and active limiter functions. Using *BESTlogicPlus* programmable logic, these outputs can be used as part of a user-configured logic scheme to control and annunciate a variety of system conditions and contingencies. Information about using the programmable outputs in a logic scheme is provided in the *BESTlogicPlus* section.

To make the programmable contact outputs easier to identify, you can assign a custom name (up to 64 alphanumeric characters) that relates to the functions of your system. Figure 7-2 shows the *BESTCOMSPlus* Contact Outputs screen where each output can be assigned a custom name.



Output #1	Output #2
Label Text	Label Text
OUTPUT 1	OUTPUT 2

Figure 7-2. Contact Output Label Text

Breaker Shunt Trip Output

This output provides an electronic switch capable of 100 mAdc that can be used to control an external circuit breaker. The breaker shunt trip output terminals are labeled ST+ and ST-.

8 • Protection

The DECS-150 offers protection relating to machine voltage, frequency, field parameters, rotating exciter diodes, and sync check over synchronism. Configurable protection elements supplement this protection with additional, user-defined system parameters that have multiple pickup thresholds per parameter. Most protection functions have two groups of settings labeled Primary and Secondary. Two setting groups enable independent protection coordination which is selectable in BESTlogic™ *Plus*.

Voltage Protection

BESTCOMS*Plus* Navigation Path: Settings Explorer, Protection, Voltage

Voltage protection includes machine undervoltage, machine overvoltage, and loss of sensing voltage.

Machine Undervoltage

An undervoltage pickup condition occurs when any phase of the sensed machine terminal voltage decreases below the Pickup setting. An undervoltage trip condition occurs if the machine voltage remains below the pickup threshold for the duration of the Time Delay setting. Machine undervoltage protection can be enabled and disabled without altering the pickup and time delay settings. Undervoltage pickup and trip elements in BESTlogic*Plus* can be used in a logic scheme to initiate corrective action in response to the condition.

Settings that are related to machine ratings can be set in either actual units of voltage or in per unit values. When a native unit is edited, BESTCOMS*Plus* automatically recalculates the per unit value based on the native unit setting and the rated data parameter (on the System Parameters, Rated Data screen) associated with it. When a per unit value is edited, BESTCOMS*Plus* automatically recalculates the native value based on the per unit setting and the rated data parameter associated with it.

Once all per unit values are assigned, if the rated data parameters are changed, BESTCOMS*Plus* automatically recalculates all native unit settings based on the modified rated data parameters.

The Undervoltage pickup has a native unit of Primary Volts and the rated data associated with it is Machine Rated Data, Voltage (on the System Parameters, Rated Data screen).

The Generator Undervoltage screen is illustrated in Figure 8-1. The Motor Undervoltage screen is similar.

Generator Undervoltage

27 Element

Primary	Secondary
Mode: Disabled	Mode: Disabled
Pickup: Primary V: 0, Per Unit: 0.000	Pickup: Primary V: 0, Per Unit: 0.000
Time Delay (s): 0.1	Time Delay (s): 0.1
Shutdown Enable: Enabled	

Figure 8-1. Generator Undervoltage Screen

Shutdown Enable

When checked, Shutdown Enable causes the DECS-150 to stop excitation when the machine undervoltage element trips.

Block Logic Input

The Block input provides logic-supervision control of the element. When true, the Block input disables the element and resets the timer. Connect the element Block input to the desired logic in BESTlogicPlus.

Machine Overvoltage

An overvoltage pickup condition occurs when any phase of the sensed machine terminal voltage increases above the Pickup setting. An overvoltage trip condition occurs if the machine voltage remains above the pickup threshold for the duration of the Time Delay setting. Machine overvoltage protection can be enabled and disabled without altering the pickup and time delay settings. Overvoltage pickup and trip elements in BESTlogicPlus can be used in a logic scheme to initiate corrective action in response to the condition.

Settings that are related to machine ratings can be set in either actual units of voltage or in per unit values. When a native unit is edited, BESTCOMSPlus automatically recalculates the per unit value based on the native unit setting and the rated data parameter (on the System Parameters, Rated Data screen) associated with it. When a per unit value is edited, BESTCOMSPlus automatically recalculates the native value based on the per unit setting and the rated data parameter associated with it.

Once all per unit values are assigned, if the rated data parameters are changed, BESTCOMSPlus automatically recalculates all native unit settings based on the modified rated data parameters.

The Overvoltage pickup has a native unit of Primary Volts and the rated data associated with it is Machine Rated Data, Voltage (on the System Parameters, Rated Data screen).

The Generator Overvoltage screen is illustrated in Figure 8-2. The Motor Overvoltage screen is similar.

The screenshot shows the 'Generator Overvoltage' configuration screen. At the top, it is labeled '59 Element'. Below this, there are two main columns: 'Primary' and 'Secondary'. Each column contains a 'Mode' dropdown menu currently set to 'Disabled'. Underneath each mode dropdown are two 'Pickup' input fields: one for 'Primary V' (set to 0) and one for 'Per Unit' (set to 0.000). Below the pickup fields is a 'Time Delay (s)' input field set to 0.1. At the bottom of the screen, there is a 'Shutdown Enable' dropdown menu set to 'Enabled'.

Figure 8-2. Generator Overvoltage Protection Settings

Shutdown Enable

When checked, Shutdown Enable causes the DECS-150 to stop excitation when the machine overvoltage element trips.

Loss of Sensing

The machine voltage is monitored for a loss of sensing (LOS) condition.

In the DECS-150, a loss of sensing event is calculated using sequence components. A loss of sensing event occurs when the positive sequence voltage (V1) drops below the Voltage Balanced Level setting of the AVR setpoint, or when the negative sequence voltage (V2) increases above the Voltage Unbalanced Level setting of the positive sequence voltage. A time delay is started when the event occurs, delaying the alarm by a predetermined time.

A loss of sensing condition can be used to initiate transfer to manual (FCR) control mode. It also can be configured in BESTlogicPlus to initiate other actions. Protection can be enabled and disabled without altering the individual loss of sensing settings.

Loss of sensing protection is automatically disabled when a short circuit exists. A short circuit is detected when the measured current is greater than twice the rated current for a single-phase CT connection and when the positive-sequence current (I_1) is greater than twice the rated current for a three-phase CT connection.

Table 8-1 defines loss of sensing trip criteria. All criteria in a single column must be met.

Table 8-1. Loss of Sensing Trip Criteria

3 Phase Sensing Selected		Single Phase Sensing Selected
$V_1 > \text{Balanced Voltage}^* \% \text{ of AVR Setpoint}$	$V_1 < \text{Balanced Voltage}^* \% \text{ of AVR Setpoint}$	Machine $V_{AVG} < \text{Balanced Voltage}^* \% \text{ of AVR Setpoint}$
$V_2 > \text{Unbalanced Voltage}^* \% \text{ of } V_1$	$I_1 < 200\% I_{rated}$	$I_1 < 200\% I_{rated}$
$I_2 < 17.7\% I_1$ or $I_1 < 1\% I_{rated}$		$I_2 < 17.7\% I_1$ or $I_1 < 1\% I_{rated}$

* Denotes the value used for the loss of sensing settings.

The Loss of Sensing screen is illustrated in Figure 8-3.

Figure 8-3. Loss of Sensing Screen

Frequency Protection

BESTCOMSPlus Navigation Path: Settings Explorer, Protection, Frequency

The frequency of the machine terminal voltage is monitored for overfrequency and underfrequency conditions.

Overfrequency

An overfrequency condition occurs when the frequency of the machine voltage exceeds the 810 pickup threshold for the duration of the 810 Time Delay setting. The Voltage Inhibit setting, expressed as a percentage of the rated machine voltage, can be implemented to prevent an overfrequency trip from occurring during startup when the machine voltage is rising toward the nominal level. Overfrequency protection can be enabled and disabled without altering the Pickup and Time Delay settings. Overfrequency pickup and trip elements in BESTlogicPlus can be used in a logic scheme to initiate corrective action in response to the condition.

The Overfrequency screen is illustrated in Figure 8-4.

Shutdown Enable

When checked, Shutdown Enable causes the DECS-150 to stop excitation when the overfrequency element trips.

The screenshot shows the 'Frequency' configuration screen. It features two columns for '81O Element' settings: 'Primary' and 'Secondary'. Each column includes a 'Mode' dropdown menu set to 'Disabled', a 'Pickup (Hz)' text box with '30.00', a 'Time Delay (s)' text box with '0.1', and a 'Voltage Inhibit (%)' text box with '50'. At the bottom, there is a 'Shutdown Enable' dropdown menu set to 'Enabled'.

Figure 8-4. Overfrequency Screen

Underfrequency

An underfrequency condition occurs when the frequency of the machine voltage decreases below the 81U pickup threshold for the duration of the 81U Time Delay setting. The Voltage Inhibit setting, expressed as a percentage of the rated machine voltage, can be implemented to prevent an underfrequency trip from occurring during startup when the machine voltage is rising toward the nominal level. Underfrequency protection can be enabled and disabled without altering the Pickup, Time Delay, and Inhibit settings. Underfrequency pickup and trip elements in *BESTlogicPlus* can be used in a logic scheme to initiate corrective action in response to the condition.

The Underfrequency screen is illustrated in Figure 8-5.

The screenshot shows the 'Frequency' configuration screen, which is identical in layout and settings to Figure 8-4. It features two columns for '81U Element' settings: 'Primary' and 'Secondary'. Each column includes a 'Mode' dropdown menu set to 'Disabled', a 'Pickup (Hz)' text box with '30.00', a 'Time Delay (s)' text box with '0.1', and a 'Voltage Inhibit (%)' text box with '50'. At the bottom, there is a 'Shutdown Enable' dropdown menu set to 'Enabled'.

Figure 8-5. Underfrequency Screen

Shutdown Enable

When checked, Shutdown Enable causes the DECS-150 to stop excitation when the underfrequency element trips.

Field Protection

BESTCOMSPlus Navigation Path: Settings Explorer, Protection, Field

Field protection provided by the DECS-150 includes exciter field current limit, field overvoltage, and an exciter diode monitor.

Exciter Field Current Limit

When checked, Shutdown Enable causes the DECS-150 to shut down excitation when the field current is too high (approximately 23 A), which could result in damage to the regulator. A restart is required to begin regulating again. The Exciter Field Current Limit screen is illustrated in Figure 8-6.

Figure 8-6. Exciter Field Current Limit Screen

Field Overvoltage

A field overvoltage condition occurs when the field voltage exceeds the pickup level for the duration of the Time Delay. Field overvoltage protection can be enabled and disabled without altering the Pickup and Time Delay settings. Field overvoltage pickup and trip elements in BESTlogicPlus can be used in a logic scheme to initiate corrective action in response to the condition.

The Field Overvoltage screen is illustrated in Figure 8-7.

Figure 8-7. Field Overvoltage Screen

Shutdown Enable

When checked, Shutdown Enable causes the DECS-150 to stop excitation when the field overvoltage element trips.

Exciter Diode Monitor

The exciter diode monitor (EDM) monitors the condition of a brushless exciter's power semiconductors by monitoring the exciter field current. The EDM detects both open and shorted rotating diodes in the exciter bridge.

Notes

All of the EDM setup guidelines presented here assume that the exciter diodes are not open or shorted at the time of setup and testing.

The EDM estimates the ripple of the exciter field current using root-mean-square (rms). The rms value of the ripple is calculated and compared to the pickup threshold for open or shorted diode detection. If the field current ripple exceeds the pickup level for the duration of the Time Delay, the condition is annunciated. EDM pickup and trip elements in BESTlogicPlus can be used in a logic scheme to initiate corrective action in response to an open or shorted diode condition.

EDM protection can be disabled and enabled by the user without altering the individual protection settings.

The Exciter Diode Monitor screen is illustrated in Figure 8-8.

Figure 8-8. Exciter Diode Monitor Screen

Finding the Maximum Field Ripple Current

To set the pickup level, the maximum ripple current on the field must be known. This can be accomplished by running the machine unloaded and at rated speed. Vary the machine voltage from minimum to maximum while monitoring the EDM ripple level on the HMI display. Record the highest value.

The DECS-150 has fixed EDM inhibit levels to prevent nuisance failed-diode indications while the machine frequency is less than 40 hertz or greater than 70 hertz.

Testing the EDM Settings

Start the machine from rest and increase the speed and voltage to the rated value. Load the machine to its rating and confirm that no failed diode annunciations occur. All of the EDM setup guidelines presented here assume that the exciter diodes were not opened or shorted at the time of setup and testing.

Shutdown Enable

When checked, Shutdown Enable causes the DECS-150 to stop excitation when the exciter diode monitor element trips.

Sync-Check Protection

BESTCOMSPlus Navigation Path: Settings Explorer, Protection, Sync Check (25)

When enabled, the sync-check (25) function supervises the automatic or manual synchronism of the controlled generator with a bus/utility. During synchronizing, the 25 function compares the voltage, slip angle, and slip frequency differences between the generator and bus. When the generator/bus differences fall within the setting for each parameter, the 25 status logic output asserts. This logic output can be configured (in BESTlogicPlus) to assert a DECS-150 contact output. This contact output can, in turn, enable the closure of a breaker tying the generator to the bus.

An Angle Compensation setting is provided to offset phase shift caused by transformers in the system. The angle compensation value is added only to the bus angle. For example, it is given that the generator and bus are synchronized but the DECS-150 metered slip angle reads -30° . Equation 8-1, below, illustrates the DECS-150 slip angle calculation. This means that the generator angle is lagging behind the bus angle by 30° due to transformer phase shift. To compensate for this phase shift, the Angle Compensation setting should contain a value of 30° . This value is added to the metered bus angle resulting in an adjusted slip angle of zero degrees. Only the metered bus angle is affected by the angle compensation setting, the metered generator angle is not biased by the DECS-150.

$$G - (B + A) = \text{Slip Angle}$$

Equation 8-1. DECS-150 Metered Slip Angle

Where:

- G = metered generator angle
- B = metered bus angle
- A = angle compensation value

When the Gen Freq > Bus Freq box is checked, the 25 status virtual output will not assert unless the generator frequency is greater than the bus frequency.

The Sync Check screen is illustrated in Figure 8-9.

The screenshot shows a configuration window titled "Sync Check" for "25 Element". It contains several input fields and dropdown menus:

- Mode:** A dropdown menu currently set to "Disabled".
- Voltage Difference (%):** A text input field containing "1.0".
- Slip Angle (°):** A text input field containing "10".
- Angle Compensation (°):** A text input field containing "0.0".
- Slip Freq (Hz):** A text input field containing "0.01".
- Gen Freq > Bus Freq:** A dropdown menu currently set to "Enabled".

Figure 8-9. Sync Check Screen

Machine Frequency Less Than 10 Hertz

A Generator/Motor Below 10 Hz condition is annunciated when the machine frequency decreases below 10 Hz or when residual voltage is low at 50/60 Hz. A Generator/Motor Below 10 Hz annunciation is automatically reset when the machine frequency increases above 10 Hz or the residual voltage increases above the threshold.

Configurable Protection

BESTCOMSPlus Navigation Path: Settings Explorer, Protection, Configurable Protection

The DECS-150 has eight configurable protection elements which can be used to supplement the standard DECS-150 protection. To make the protection elements easier to identify, each element can be given a user-assigned name of up to 16 alphanumeric characters. A protection element is configured by selecting the parameter to be monitored and then establishing the operating characteristics for the element.

Protection will always be enabled when Stop mode is not inhibited. When Stop mode is inhibited, protection can be enabled only when the DECS-150 is enabled and supplying excitation. When protection is enabled only in Start mode, an arming time delay can be used to delay protection following the start of excitation.

A hysteresis function holds the protection function active for a user-defined percentage above/below the pickup threshold. This prevents repeated pickups and dropouts where the monitored parameter is hovering around the pickup threshold. For example, with a hysteresis setting of 5% on a protection element configured to pick up at 100 Aac of A-phase machine overcurrent, the protection element would pick up when the current rises above 100 Aac and remain picked up until the current decreases below 95 Aac.

Each of the eight configurable protection elements has four individually-adjustable thresholds. Each threshold can be set for pickup when the monitored parameter increases above the pickup setting (Over), pickup when the monitored parameter decreases below the pickup setting (Under), or no pickup

(Disabled). The pickup level for the monitored parameter is defined by a Threshold setting. While the threshold setting range is broad, you must use a value within the setting range limits for the monitored parameter. Using an out-of-limits threshold will prevent the protection element from functioning. An activation delay serves to delay a protective trip after the threshold (pickup) level is exceeded.

The Configurable Protection #1 screen is illustrated in Figure 8-10.

Configurable Protection #1

Label Text
CONF PROT 1

Parameter Selection
Gen VAB

Stop Mode Inhibit
No

Arming Delay (s)
0

Hysteresis (%)
2.0

Threshold #1		
Mode	Threshold	Activation Delay (s)
Disabled	0.00	0

Threshold #2		
Mode	Threshold	Activation Delay (s)
Disabled	0.00	0

Threshold #3		
Mode	Threshold	Activation Delay (s)
Disabled	0.00	0

Threshold #4		
Mode	Threshold	Activation Delay (s)
Disabled	0.00	0

Figure 8-10. Configurable Protection #1 Screen

9 • Limiters

DECS-150 limiters ensure that the controlled machine does not exceed its capabilities. Overexcitation, underexcitation, stator current, and reactive power are limited by the DECS-150. It also limits the machine voltage during underfrequency conditions.

Overexcitation Limiter

BESTCOMSPlus Navigation Path: Settings Explorer, Operating Settings, Limiters, OEL

Operating in the overexcited region of a machine's capability curve can cause excessive field current and field winding heating. The overexcitation limiter (OEL) monitors the level of field current supplied by the DECS-150 and limits it to prevent field overheating.

The OEL can be enabled in all regulation modes. OEL behavior in manual mode can be configured to limit excitation or issue an alarm. This behavior is configured in BESTlogic™ Plus.

Two styles of overexcitation limiting are available in the DECS-150: Summing Point or Takeover. OEL configuration settings are illustrated in Figure 9-1.

OEL Voltage Dependency

The OEL voltage dependency function is applicable to only Summing Point style. It is used to enable the OEL High-Level setting when a fault is present. The OEL High-Level setting is enabled when the dv/dt level is less than the setting. Otherwise, only the Medium-Level and Low-Level settings are enabled.

OEL Shutdown

When this setting is enabled and the OEL limiter is active, the DECS-150 will shut down after the Shutdown Delay time expires.

The screenshot shows the 'OEL Configure' screen with the following settings:

- OEL Configuration**
 - OEL Enable: Disabled
 - OEL Mode: Summing Point
- OEL Voltage Dependency**
 - dv/dt Enable: Enabled
 - dv/dt Level: -5.00
- OEL Shutdown**
 - Shutdown Enable: Enabled
 - Shutdown Delay (s): 10.0

Figure 9-1. OEL Configure Screen

Summing Point OEL

Summing point overexcitation limiting compensates for field overcurrent conditions while the machine is offline or online. Offline and online OEL behavior is dictated by two separate groups of settings. Primary and secondary setting groups (selectable in configurable logic) provide additional control for two distinct machine operating conditions.

Offline Operation

For offline operation, there are two levels of summing-point overexcitation limiting: High and Low. Figure 9-2 illustrates the relationship of the high-level and low-level OEL thresholds.

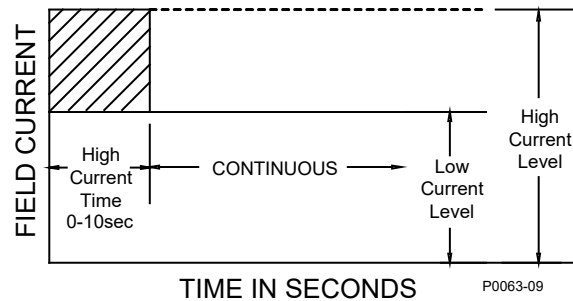


Figure 9-2. Summing Point, Offline, Overexcitation Limiting

The offline, high-level OEL threshold is determined by the High Level and High Time settings. When the excitation level exceeds the High Level setting, the DECS-150 acts to limit the excitation to the value of the High-Level setting and a High Level Timer is initiated. If this level of excitation persists until this timer reaches the High Time setting, the DECS-150 acts to limit the excitation to the value of the Low-Level setting. The Ambient Temperature setting on the Rated Data Settings screen determines the high-level range.

The offline, low-level OEL threshold is determined by the Low Level setting. When the OEL becomes inactive, the High Current Timer counts down from either the high time, if the High Current Timer has expired, or from the amount of time spent at high level, if the High Current Timer has not expired. The generator is permitted to operate indefinitely with this level of excitation. The Ambient Temperature setting on the Rated Data Settings screen determines the low-level range.

Online Operation

For online operation, there are three levels of summing-point overexcitation limiting: low, medium, and high. Figure 9-3 illustrates the relationship of the high-, medium-, and low-level OEL thresholds.

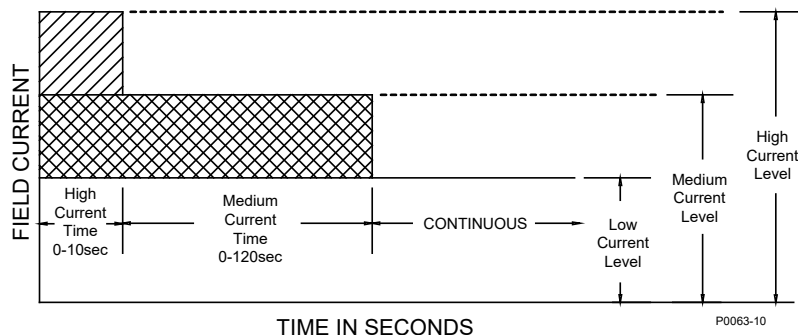


Figure 9-3. Summing Point, Online, Overexcitation Limiting

The online, high-level OEL threshold is determined by the High Level and High Time settings. When the excitation level exceeds the High Level setting, the DECS-150 instantaneously acts to limit the excitation to the value of the High Level setting. If this level of excitation persists for the duration of the High Time setting, the DECS-150 acts to limit the excitation to the value of the High Level setting. The Ambient Temperature setting on the Rated Data Settings screen determines the high-level range.

The online, medium-level OEL threshold is determined by the Medium Level and Medium Time settings. When the excitation level exceeds the Medium Level setting for the duration of the Medium Time setting, the DECS-150 acts to limit the excitation to the value of the Low Level setting. The Ambient Temperature setting on the Rated Data Settings screen determines the medium-level range.

The online, low-level OEL threshold is determined by the Low Level setting. When the excitation level is below the Low Level setting, no action is taken by the DECS-150. The generator is permitted to operate indefinitely with this level of excitation. When the excitation level exceeds the Low Level setting for the duration of the high and medium time settings, the DECS-150 acts to limit the excitation to the value of the Low Level setting. The Ambient Temperature setting on the Rated Data Settings screen determines the low-level range.

Settings that are related to machine ratings can be set in either actual units of voltage or in per unit values. When a native unit is edited, BESTCOMSP^l automatically recalculates the per unit value based on the native unit setting and the rated data parameter (on the System Parameters, Rated Data screen) associated with it. When a per unit value is edited, BESTCOMSP^l automatically recalculates the native value based on the per unit setting and the rated data parameter associated with it.

Once all per unit values are assigned, if the rated data parameters are changed, BESTCOMSP^l automatically recalculates all native unit settings based on the modified rated data parameters.

The levels have native units of Primary Amps and the rated data associated with them is Machine Rated Data, Current (on the System Parameters, Rated Data screen).

Summing point OEL settings are illustrated in Figure 9-4.

OEL Summing Point

Mode	Level	Value	Unit	
Primary	Off-Line	High Level	0.0 Primary A	
			0.000 Per Unit	
		High Time (s)	0	
	Low Level		0.0 Primary A	
			0.000 Per Unit	
	On-Line	High Level		0.0 Primary A
				0.000 Per Unit
			High Time (s)	0
		Medium Level		0.0 Primary A
				0.000 Per Unit
	Medium Time (s)	0		
Low Level			0.0 Primary A	
			0.000 Per Unit	
		High Time (s)	0	
	Medium Level		0.0 Primary A	
			0.000 Per Unit	
	Medium Time (s)	0		
Secondary	Off-Line	High Level	0.0 Primary A	
			0.000 Per Unit	
		High Time (s)	0	
	Low Level		0.0 Primary A	
			0.000 Per Unit	
	On-Line	High Level		0.0 Primary A
				0.000 Per Unit
			High Time (s)	0
		Medium Level		0.0 Primary A
				0.000 Per Unit
	Medium Time (s)	0		
Low Level			0.0 Primary A	
			0.000 Per Unit	
		High Time (s)	0	
	Medium Level		0.0 Primary A	
			0.000 Per Unit	
	Medium Time (s)	0		

Figure 9-4. Summing Point OEL Screen

Takeover OEL

Takeover OEL limits the field current level in relation to an inverse time characteristic similar to that shown in Figure 9-5. Separate curves may be selected for online and offline operation. If the system enters an overexcitation condition, the field current is limited and forced to follow the selected curve. The inverse time characteristic is defined by Equation 9-1.

$$t_{pickup} = \frac{A \times TD}{B + \sqrt{C + D \times MOP}}$$

Equation 9-1. Inverse Pickup Time Characteristic

Where:

t_{pickup} = time to pick up in seconds

A = -95.908

B = -17.165

C = 490.864

D = -191.816

TD = time dial setting <0.1, 20>

MOP = multiple of pickup <1.03, 205>

Primary and secondary setting groups provide additional control for two distinct machine operating conditions. Each mode of takeover OEL operation (offline and online) has a Low-Level, High-Level, and Time Dial setting. The Ambient Temperature setting on the Rated Data Settings screen determines the low- and high-level ranges.

Once the field current decreases below the dropout level (95% of pickup), the function is reset based on the selected reset method. The available reset methods are inverse, integrating, and instantaneous.

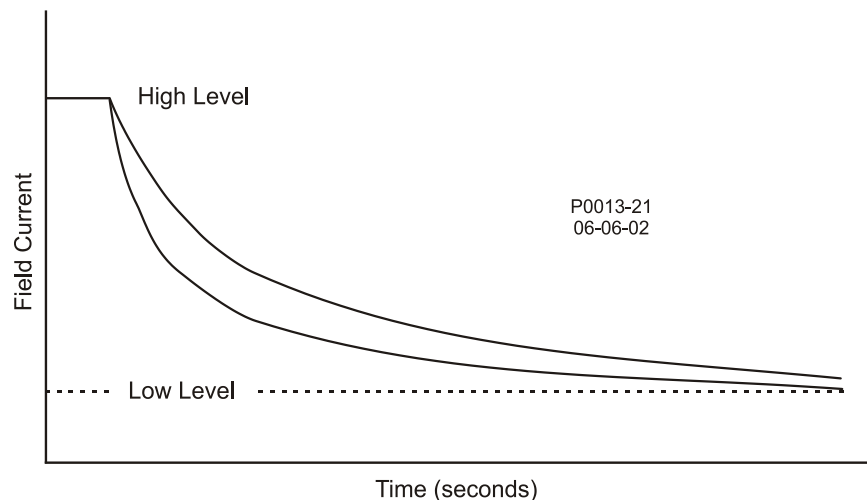


Figure 9-5. Inverse Time Characteristic for Takeover OEL

Using the inverse method, the OEL is reset based on time versus multiple of pickup (MOP). The lower the field current level, the less time is required for reset. Inverse reset uses the following curve (Equation 9-2) to calculate maximum reset time.

$$\text{Reset Time Constant} = \frac{RC \times TD \times 0.05}{1 - (MOP \times 1.03)^2}$$

Equation 9-2. Inverse Reset Time Characteristic

Where:

Reset Time Constant = maximum time to reset in seconds

RC = reset coefficient setting <0.01, 100>

TD = time dial setting <0.1, 20>

MOP = multiple of pickup

For the integrating reset method, the reset time is equal to the pickup time. In other words, the amount of time spent above the low level threshold is the amount of time required to reset.

Instantaneous reset has no intentional time delay.

In BESTCOMSPi^{us}®, a plot of the takeover OEL setting curves is displayed. Settings enable selection of the displayed curves. The plot can display the primary or secondary setting curves, the offline or online settings curves, and the pickup or reset settings curves.

Settings that are related to machine ratings can be set in either actual units of voltage or in per unit values. When a native unit is edited, BESTCOMSP^{Plus} automatically recalculates the per unit value based on the native unit setting and the rated data parameter (on the System Parameters, Rated Data screen) associated with it. When a per unit value is edited, BESTCOMSP^{Plus} automatically recalculates the native value based on the per unit setting and the rated data parameter associated with it.

Once all per unit values are assigned, if the rated data parameters are changed, BESTCOMSP^{Plus} automatically recalculates all native unit settings based on the modified rated data parameters.

The levels have native units of Primary Amps and the rated data associated with them is Machine Rated Data, Current (on the System Parameters, Rated Data screen).

Takeover OEL settings are illustrated in Figure 9-6.

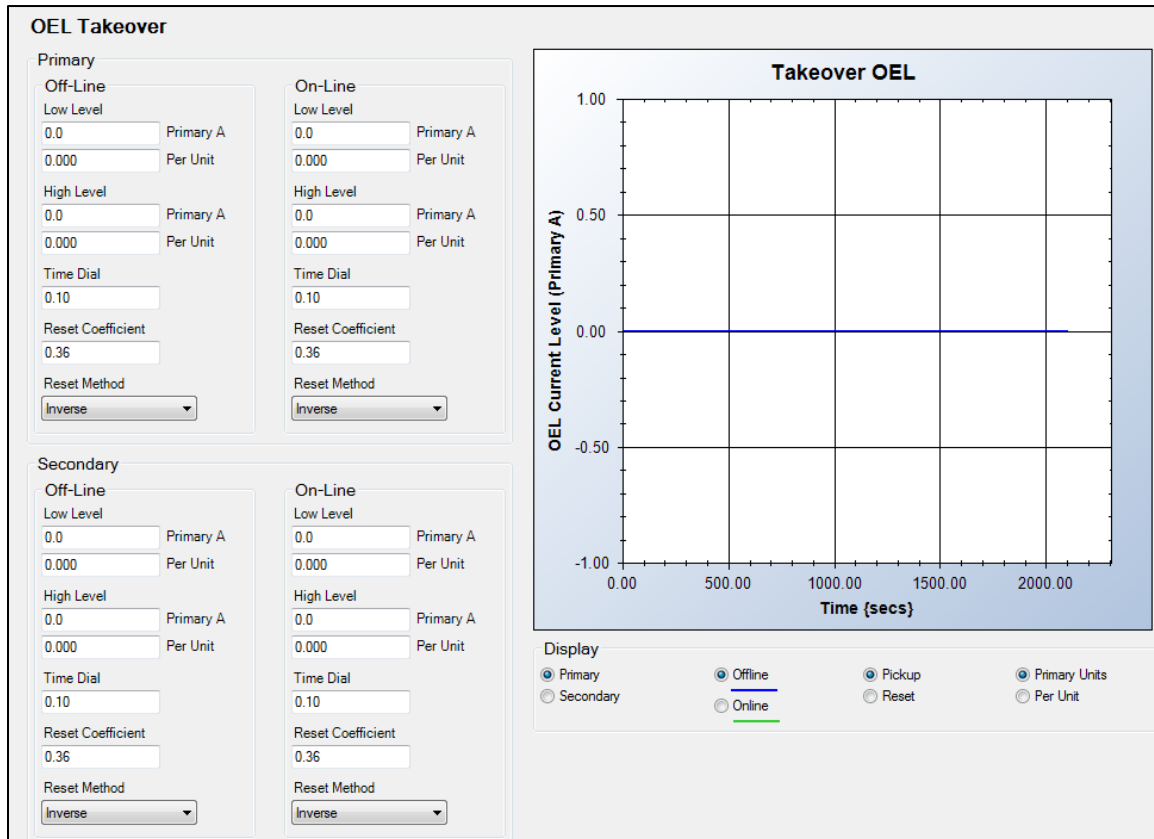


Figure 9-6. Takeover OEL Screen

Underexcitation Limiter

BESTCOMSP^{Plus} Navigation Path: Settings Explorer, Operating Settings, Limiters, UEL

Operating a machine in an underexcited condition can cause the stator end iron to overheat. Extreme underexcitation may lead to a loss of synchronism. The underexcitation limiter (UEL) senses the leading var level of the machine and limits decreases in excitation to limit end-iron heating. When enabled, the UEL operates in all regulation modes. UEL behavior in manual mode can be configured to limit excitation or issue an alarm. This behavior is configured in BESTlogic^{Plus}.

Note

For UEL to operate, the PARALLEL_ENABLE_LM logic block must be set true in BESTlogic^{Plus} programmable logic.

UEL Voltage Dependency

The levels entered for the user-defined curve are defined for operation at the rated machine voltage. The user-defined UEL curve can be automatically adjusted based on machine operating voltage by using the UEL voltage dependency real-power exponent. The user-defined UEL curve is automatically adjusted based on the ratio of the machine operating voltage to the machine rated voltage raised to the power of the UEL voltage dependency real-power exponent. UEL voltage dependency is further defined by a real power filter time constant that is applied to the low-pass filter for the real power output.

UEL Shutdown

When this setting is enabled and the UEL limiter is active, the DECS-150 will shut down after the shutdown delay time expires.

UEL configuration settings are illustrated in Figure 9-7.

The screenshot shows a configuration window titled "UEL Configure". It is divided into two main sections:

- UEL Configuration:**
 - An "Enable" checkbox is present.
 - Under "UEL Voltage Dependency":
 - "Real Power Exponent" is set to 2.00.
 - "Real Power Filter Time Constant (s)" is set to 5.0.
- UEL Shutdown:**
 - "Shutdown Enable" checkbox is checked.
 - "Shutdown Delay (s)" is set to 10.0.

Figure 9-7. UEL Configure Screen

UEL Curve

Underexcitation limiting is implemented through an internally-generated UEL curve or a user-defined UEL curve. The internally-generated curve is based on the desired reactive power limit at zero real power with respect to the machine voltage and current rating. The absorbed reactive power axis of the curve on the UEL Custom Curve screen can be tailored for your application.

A user-defined curve can have a maximum of five points. This curve allows the user to match a specific machine characteristic by specifying the coordinates of the intended leading reactive power (kvar) limit at the appropriate real power (kW) level.

UEL configuration settings are illustrated in Figure 9-8.

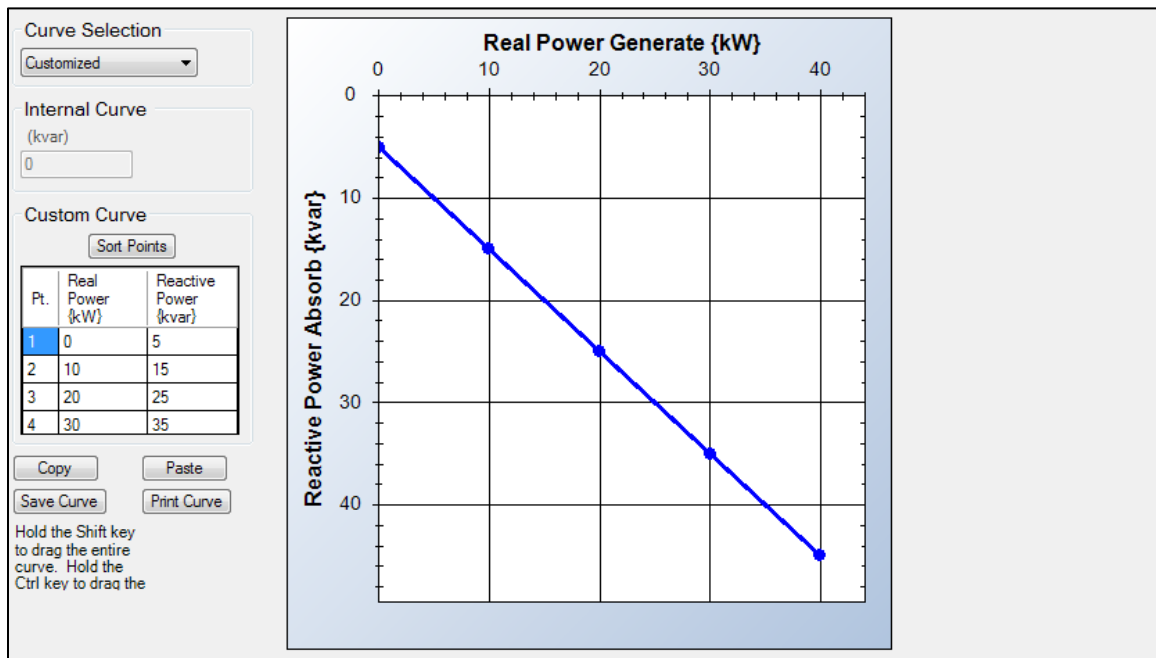


Figure 9-8. UEL Custom Curve Screen

Stator Current Limiter

BESTCOMSPlus Navigation Path: Settings Explorer, Operating Settings, Limiters, SCL

The stator current limiter (SCL) monitors the level of stator current and limits it to prevent stator overheating. To limit the stator current, the SCL modifies the excitation level according to the direction of var flow into or out of the machine. Excessive stator current with leading power factor calls for increased excitation. Excessive stator current with lagging power factor calls for reduced excitation.

The SCL can be enabled in all regulation modes. When operating in Manual mode, the DECS-150 will announce high stator current but will not act to limit it. Primary and secondary SCL setting groups provide additional control for two distinct machine operating conditions. Stator current limiting is provided at two levels: low and high (see Figure 9-9).

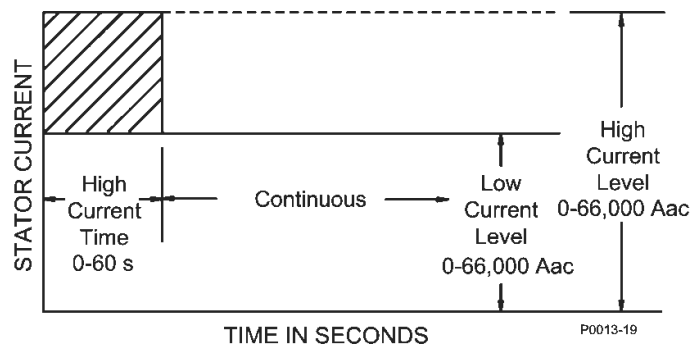


Figure 9-9. Stator Current Limiting

Settings that are related to machine ratings can be set in either actual units of current or in per unit values. When a native unit is edited, BESTCOMSPlus automatically recalculates the per unit value based on the native unit setting and the rated data parameter (on the System Parameters, Rated Data screen) associated with it. When a per unit value is edited, BESTCOMSPlus automatically recalculates the native value based on the per unit setting and the rated data parameter associated with it.

Once all per unit values are assigned, if the rated data parameters are changed, BESTCOMSPlus automatically recalculates all native unit settings based on the modified rated data parameters.

The levels have native units of Primary Amps and the rated data associated with them is Machine Rated Data, Current (on the System Parameters, Rated Data screen).

SCL settings are illustrated in Figure 9-10.

Low Level Limiting

When the stator current exceeds the Low Level setting, the DECS-150 annunciates the elevated level. If this condition persists for the duration of the High SCL Time setting, the DECS-150 acts to limit the current to the Low Level SCL setting. When the stator current is below the Low Level setting, no SCL limiting action is taken by the DECS-150. The High Current Timer counts down either from the high time, if the High Current Timer has expired, or from the amount of time spent at high level, if the High Current Timer has not expired. The machine is permitted to operate indefinitely at or below the low-level threshold.

High Level Limiting

When the stator current exceeds the High Level setting, the DECS-150 acts to limit the current to the value of the High Level setting and a High Level Timer is initiated. If this level of current persists until this timer reaches the High Level Time setting, the DECS-150 acts to limit the current to the value of the Low Level SCL setting.

Initial Delay

In the case of low- or high-level stator current limiting, the limiting function will not respond until an initial time delay expires.

SCL Shutdown

When this setting is enabled and the SCL limiter is active, the DECS-150 will shut down after the shutdown delay time expires.

SCL

Stator Current Limiter
Stator Current Limiter
Disabled

Primary	Secondary
Initial Delay (s) 0.0	Initial Delay (s) 0.0
High SCL Level 0.0 Primary A 0.000 Per Unit	High SCL Level 0.0 Primary A 0.000 Per Unit
High SCL Time (s) 0.0	High SCL Time (s) 0.0
Low SCL Level 0.0 Primary A 0.000 Per Unit	Low SCL Level 0.0 Primary A 0.000 Per Unit

SCL Shutdown
Shutdown Enable
Enabled

Shutdown Delay (s)
10.0

Figure 9-10. SCL Screen

Underfrequency Limiter

BESTCOMSPlus Navigation Path: Settings Explorer, Operating Settings, Limiters, Underfrequency

The underfrequency limiter is selectable for underfrequency limiting or volts per hertz limiting. These limiters protect the machine from damage due to excessive magnetic flux resulting from low frequency and/or overvoltage.

Underfrequency

If the machine frequency decreases below the corner frequency for the selected underfrequency slope (Figure 9-11), the DECS-150 adjusts the voltage setpoint so that the machine voltage follows the underfrequency slope. The adjustment range of the corner frequency and slope settings enables the DECS-150 to precisely match the operating characteristics of the prime mover and the loads being applied to the machine.

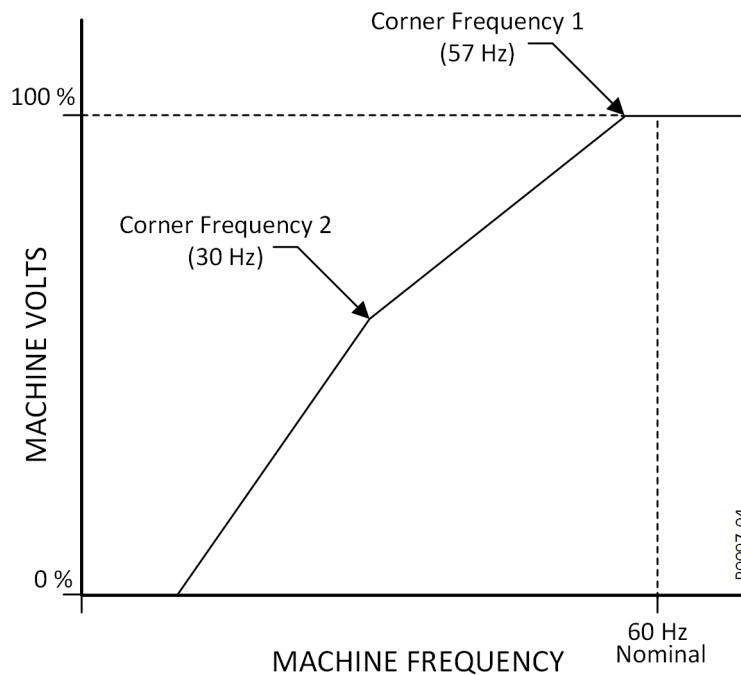


Figure 9-11. Typical Underfrequency Compensation Curve

Reset Time

The reset function introduces a time-based response to the recovery of the voltage based upon the recovery of the speed, magnitude of the voltage dip, and the Reset Time setting in BESTCOMSPlus. After speed begins to recover, the reset time is used to calculate the voltage recovery ramp time. The reset time reduces the machine kW below the available engine kW during the recovery period, thus allowing an improved speed recovery. This control is effective only during load switching when the speed decreases below the underfrequency knee setting. If the speed stays above the knee during a load transient, the reset function will have no effect on the recovery. This feature is typically used with a generator coupled to a turbocharged engine with limited block load acceptance. When the reset time is set to zero (0), the response will follow the V/Hz curve selected.

Volts per Hertz

The volts per hertz limiter prevents the regulation setpoint from exceeding the volts per hertz ratio defined by the V/Hz High Limiter and V/Hz Low Limiter settings. The High Limiter setting establishes the maximum threshold for volts per hertz limiting, the Low Limiter setting establishes the minimum threshold for volts per hertz limiting, and the Time Limiter setting establishes the time delay for limiting. A typical volts per hertz limiter curve is illustrated in Figure 9-12.

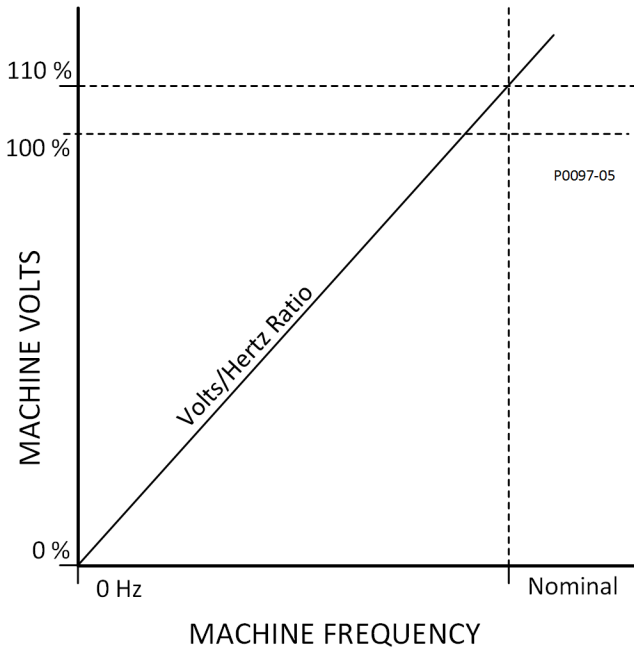


Figure 9-12. Typical 1.1 PU Volts per Hertz Limiter Curve

Underfrequency and volts per hertz limiter settings are illustrated in Figure 9-13.

Underfrequency

<p>Limiters Mode</p> <p>Mode</p> <p>UF Limiter</p>	<p>Underfrequency Limiter</p> <p>Corner Frequency (Hz)</p> <p>57.0</p> <p>Slope</p> <p>1.00</p>	<p>Corner Frequency 2 (Hz)</p> <p>57.0</p> <p>Slope 2</p> <p>1.00</p> <p>Reset Time (s)</p> <p>0.0</p>	<p>Volts/Hz Limiter</p> <p>V/Hz High Limiter</p> <p>1.00</p> <p>V/Hz Low Limiter</p> <p>1.00</p> <p>V/Hz Time Limiter (s)</p> <p>10.0</p>
----------------------------------------------------	-------------------------------------------------------------------------------------------------	--------------------------------------------------------------------------------------------------------	-------------------------------------------------------------------------------------------------------------------------------------------

Figure 9-13. Underfrequency Screen

Underfrequency Volts/Hz Disable

When true, the UNDERFREQUENCY_VHZ_DISABLE logic block disables the Volts/Hz limiter. Refer to the *BESTlogicPlus* section for more information.

10 • Grid Code

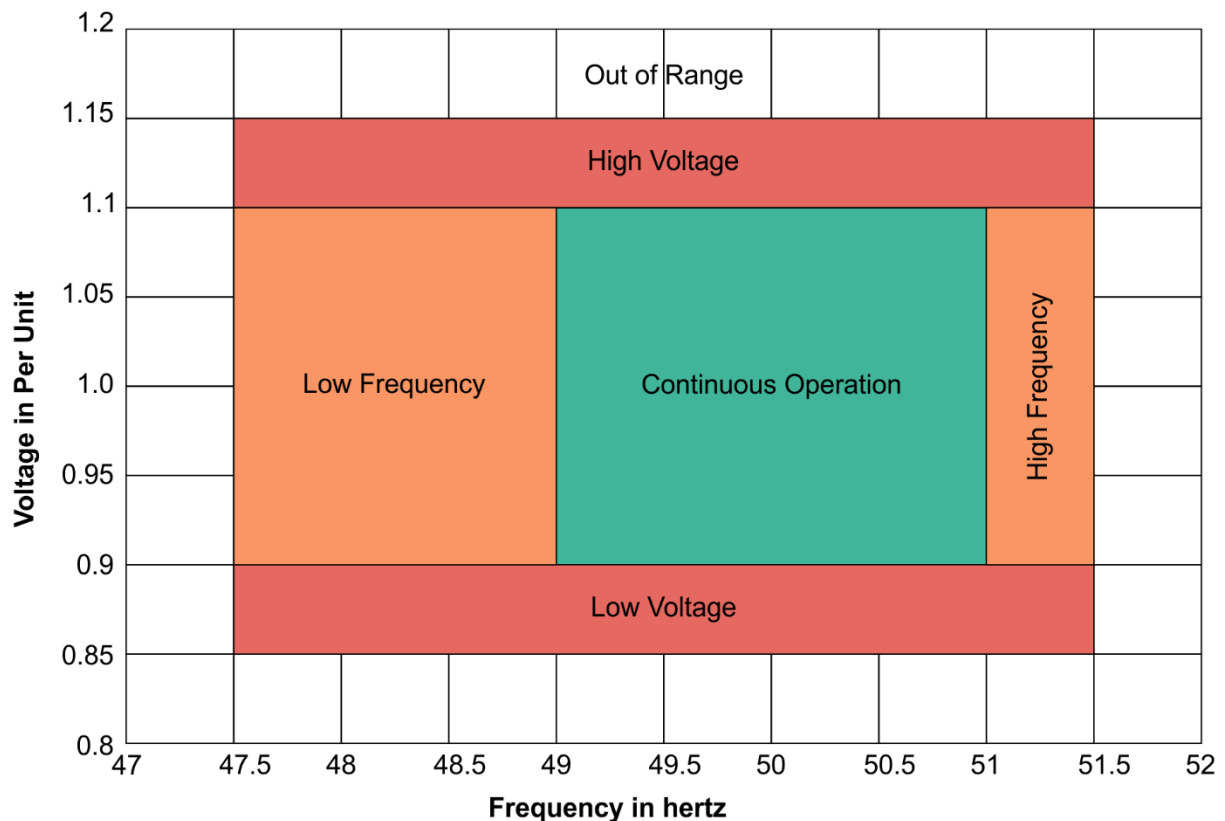
This section only applies to generator applications. Grid Code settings make the DECS compatible with grid code compliant systems. Grid Code mode settings consist of grid connectivity parameters, active power control parameters, and reactive power control parameters. These settings are defined in the following paragraphs.

Configuration

BESTCOMSPlus Navigation Path: Settings Explorer, Grid Code Settings, Configure

HMI Navigation Path: Settings, Operating Settings, Grid Code Settings, Grid Code Configure

Grid Code compliant generating units must remain connected to the grid during grid instability for a set amount of time within certain voltage and frequency limits. See Figure 10-1.



P0087-76

Figure 10-1. Generator Operation Regions

The Continuous Operation region in Figure 10-1 is defined by four settings: Max Frequency for Continuous Operation, Min Frequency for Continuous Operation, Max Voltage for Continuous Operation, and Min Voltage for Continuous Operation.

High and Low Frequency

The High Frequency region in Figure 10-1 is defined by two settings: Max Frequency for Disconnect and Max Frequency for Continuous Operation. When grid frequency is within the range defined by these two settings, the Frequency Disconnect timer is active.

The Low Frequency region in Figure 10-1 is defined by two settings: Min Frequency for Disconnect and Min Frequency for Continuous Operation. When grid frequency is within the range defined by these two settings, the Frequency Disconnect timer is active.

High and Low Voltage

The High Voltage region in Figure 10-1 is defined by two settings: Max Voltage for Disconnect and Max Voltage for Continuous Operation. When grid voltage is within the range defined by these two settings, the Voltage Disconnect timer is active.

The Low Voltage region in Figure 10-1 is defined by two settings: Min Voltage for Disconnect and Min Voltage for Continuous Operation. When grid voltage is within the range defined by these two settings, the Voltage Disconnect timer is active.

Out of Range

When grid voltage or frequency is outside of the regions shown in Figure 10-1, the Grid Disconnect timer is active.

Disconnection Timers

When the Frequency Disconnect Timer, Voltage Disconnect Timer, or the Grid Disconnect Timer expires, the generating unit is permitted to disconnect from the grid.

Note
Rather than performing the disconnection, the DECS-150 issues a logic indication which can be used to energize a physical output. See the BESTlogic™ Plus section for details on the GCC Disconnected status input.

The duration of the Frequency Disconnect timer is defined by the Frequency Disconnect Time Delay setting, the Voltage Disconnect timer is defined by the Voltage Disconnect Time Delay setting, and the Grid Disconnect timer is defined by the Grid Disconnect Time Delay setting. The Grid Disconnect timer may be set to 0 for immediate disconnection.

Grid Recovery Mode

Once the generating unit has disconnected from the grid due to expiration of the Grid Disconnect timer, the DECS enters Grid Recovery Mode. In this mode, grid voltage and frequency are monitored and must remain within certain limits for a period of time to ensure stability. The grid recovery frequency limits are defined by the Max Frequency for Reconnect and Min Frequency for Reconnect settings. The grid recovery voltage limits are defined by the Max Voltage for Reconnect and Min Voltage for Reconnect settings. The grid recovery stability time is defined by the Grid Reconnect Stability Timer setting.

Configure

Configure

Grid Code Enable

Enabled ▾

Grid Connection

Steady State Operation

Max Frequency For Continuous Operation (Hz)
51.000

Min Frequency For Continuous Operation (Hz)
49.000

Max Voltage For Continuous Operation (pu)
1.100

Min Voltage For Continuous Operation (pu)
0.900

Max Frequency For Disconnect (Hz)
51.500

Min Frequency For Disconnect (Hz)
47.500

Frequency Disconnect Time Delay (min)
30.0

Max Voltage For Disconnect (pu)
1.150

Min Voltage For Disconnect (pu)
0.850

Voltage Disconnect Time Delay (s)
60.00

Grid Disconnect Time Delay (s)
0.000

Reconnect

Max Frequency for Reconnect (Hz)
50.100

Min Frequency for Reconnect (Hz)
49.900

Max Voltage for Reconnect (pu)
1.100

Min Voltage for Reconnect (pu)
0.950

Grid Reconnect Stability Timer (min)
10.0

Figure 10-2. Configure Screen

Active Power Control (APC)

BESTCOMSPlus Navigation Path: Settings Explorer, Grid Code Settings, Active Power Control

HMI Navigation Path: Settings, Operating Settings, Grid Code Settings, Active Power Control

The DECS-150 runs in Active Power Control mode continuously when grid frequency is normal (within the dead band). It shifts into Limited Frequency Sensitive Mode (LFSM) when grid frequency is outside the dead band. Then it shifts into Grid Recovery mode for a set period of time once grid frequency returns to within the dead band.

APC Mode

When enabled, APC mode limits the generating unit's ramp rates for increasing and decreasing output. The active power setpoint can be adjusted through analog inputs or remote communication protocols. Alternatively, one of four active power levels can be selected through logic.

Active Power Control Settings

The active power setpoint, the maximum setpoint limit, and the minimum setpoint limit are established by the Active Power Setpoint, Max Active Power Setpoint, and Min Active Power Setpoint settings, respectively.

Power output ramp rates are established by the Normal Power Increase Rate and Normal Power Decrease Rate settings. These rates are used when Active Power Control mode is active.

Active Power Level Selection Settings

When the Active Power Input Source setting is set to Active Power Level Selection, the Active Power Setpoint setting is not used.

Each of the four Active Power Level settings corresponds to an input on the Active Power Level Select logic element (Figure 10-3). See the *BESTlogicPlus* section for details.

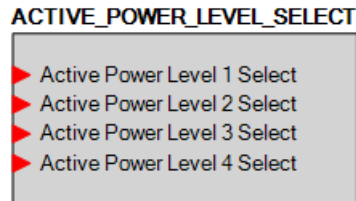


Figure 10-3. Active Power Level Select Logic Element

Adjustment Sources

The active power setpoint may be adjusted by the DECS-150 auxiliary input or via remote communication (Modbus®). For all adjustment sources, the value of the APC Gain setting is applied to the value read from the selected input. Refer to the *Modbus Communication* section for more information on adjusting the setpoint via remote communication.

Auxiliary Input

To use the DECS-150 auxiliary input as the grid code Active Power Control adjustment source, make the following settings:

- On the Auxiliary Input screen, set the Input Function setting to Grid Code Input. Refer to the *Auxiliary Control* section for details.
- On the Active Power Control screen, set the Adjust Source setting to Auxiliary Input.

Refer to the *Auxiliary Control* section for details on how the auxiliary voltage (V_{aux}) is calculated.

V_{aux} is multiplied by 0.01 and the value of the APC Gain setting:
($APC\ Adjust = V_{aux} \times 0.01 \times APC\ Gain$).

Active Power PI Controller Settings

Gains are established by the Loop Gain (Kg) and Integral Gain (Ki) settings. Maximum and minimum power output is established by the Max Power Output and Min Power Output settings.

APC Bridging

When APC Bridging is enabled, a third-party active power setpoint is inserted directly into the output of the active power control functionality. The value can be read from the DECS-150 Modbus register containing the APC output value. This bypasses the DECS-150's active power control modes.

LFSM

When grid frequency exceeds the dead band threshold, LFSM becomes the active control mode, if enabled. During over or underfrequency conditions, output power should change as fast as possible to respond to the change requested by the curve illustrated in Figure 10-4. When frequency is low, the generating units increase their output power to support the grid. When frequency is high, the generating units decrease their output power to help prevent grid frequency from rising further.

LFSM Dead Band Settings

The LFSM-U Dead Band setting establishes the deadband minimum frequency and the LFSM-O Dead Band setting establishes the deadband maximum frequency.

LFSM Droop Settings

The LFSM-U Droop setting establishes the underfrequency droop curve and the LFSM-O establishes the overfrequency droop curve. These curves, represented by the green lines in Figure 10-4, do not necessarily have to be the same.

LFSM Max Power Limit Settings

The LFSM-U Max Power Limit Start Frequency setting establishes the frequency at which the generating unit can limit maximum output power during underfrequency conditions. The LFSM-O Max Power Limit Start Frequency setting establishes the frequency at which the generating unit can limit maximum output power during overfrequency conditions.

The LFSM-U Max Power Limit Derate setting establishes the power output derating curve for an underfrequency condition. The LFSM-O Max Power Limit Derate setting establishes the power output derating curve for an overfrequency condition. These curves, represented by the blue lines in Figure 10-4, do not necessarily have to be the same.

LFSM Power Ramp Rate Settings

Power output ramp rates are established by the LFSM Power Increase Rate and LFSM Power Decrease Rate settings. These rates are used when LFSM is active.

Limited Frequency Sensitive Mode Characteristic and Maximum Power Limit Characteristic

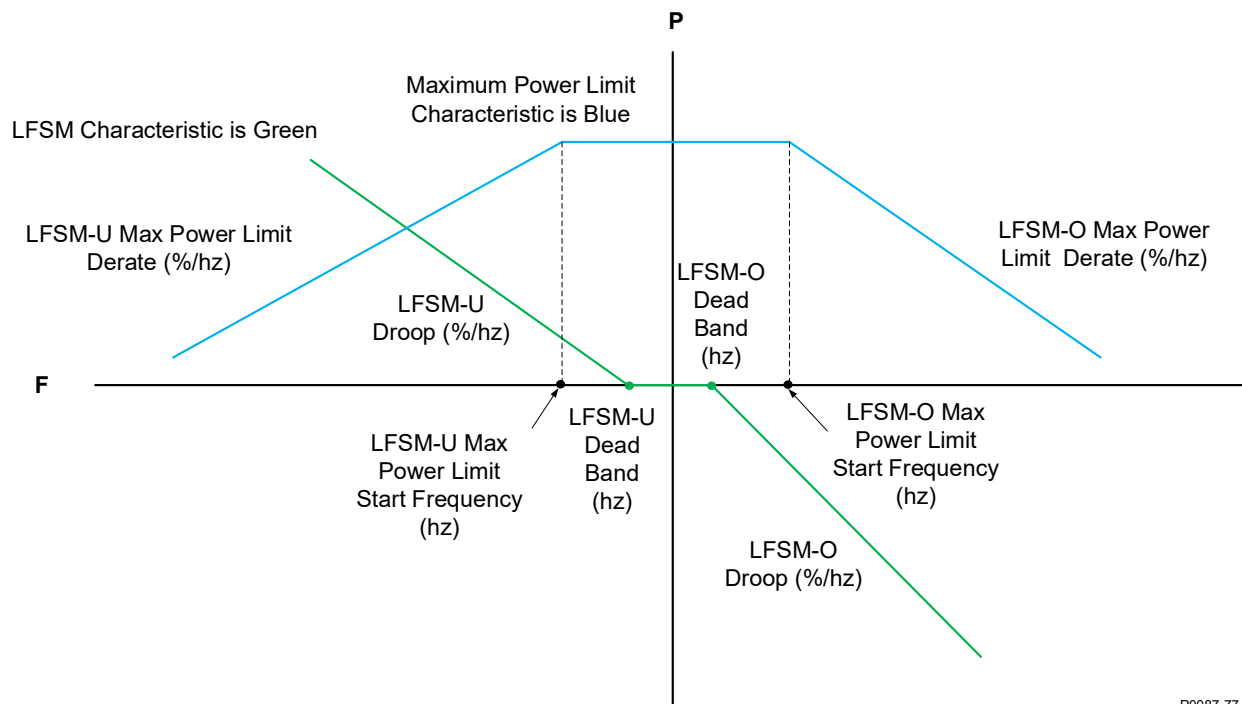


Figure 10-4. LFSM Characteristic and Maximum Power Limit Characteristic

Grid Recovery Mode

When the DECS-150 is operating in LFSM and the grid frequency returns to normal (within the dead band), Grid Recovery mode becomes the active control mode. In this mode, grid recovery ramp rates are used and grid frequency must remain within the dead band for the duration for the grid recovery timer before returning to Active Power Control mode.

Grid Recovery Settings

The Recovery Time setting establishes the amount of time the grid frequency must remain within the dead band before the grid is deemed stable and the DECS-150 can return to Active Power Control mode.

Power output ramp rates are established by the Recovery Power Increase Rate and Recovery Power Decrease Rate settings. These rates are used when Grid Recovery mode is active.

Active Power Control

Configure

Active Power Control Enable: Disabled
 Active Power Input Source: Active Power Setpoint
 Adjust Source: None
 Gain: 1.000

LFSM Enable: Disabled
 APC Bridging Enable: Disabled

Active Power Control

Active Power Setpoint (pu): 0.000
 Maximum Active Power Setpoint (pu): 1.000
 Minimum Active Power Setpoint (pu): 0.000
 Normal Power Increase Rate (%/sec): 0.660
 Normal Power Decrease Rate (%/sec): 0.660

Active Power Level Selection

Active Power Level 1 (pu): 0.000
 Active Power Level 2 (pu): 0.300
 Active Power Level 3 (pu): 0.600
 Active Power Level 4 (pu): 1.000

Limited Frequency Sensitivity Mode

LFSM-U Dead Band (Hz): 49.800
 LFSM-O Dead Band (Hz): 50.200
 LFSM-U Droop (%/Hz): 40.000
 LFSM-O Droop (%/Hz): 40.000
 LFSM-U Max Power Limit Start Frequency (Hz): 49.500
 LFSM-O Max Power Limit Start Frequency (Hz): 50.500
 LFSM-U Max Power Limit Derate (%/Hz): 10.000
 LFSM-O Max Power Limit Derate (%/Hz): 0.000
 LFSM Power Increase Rate (%/sec): 0.660
 LFSM Power Decrease Rate (%/sec): 0.660

Grid Recovery

Recovery Time (min): 10.0
 Recovery Power Increase Rate (%/sec): 0.167
 Recovery Power Decrease Rate (%/sec): 0.167

Active Power PI Controller

Loop Gain (Kg): 1.000
 Integral Gain (Kg): 0.000
 Max Power Output (pu): 1.000
 Min Power Output (pu): -1.000

Figure 10-5. Active Power Control

Reactive Power Control

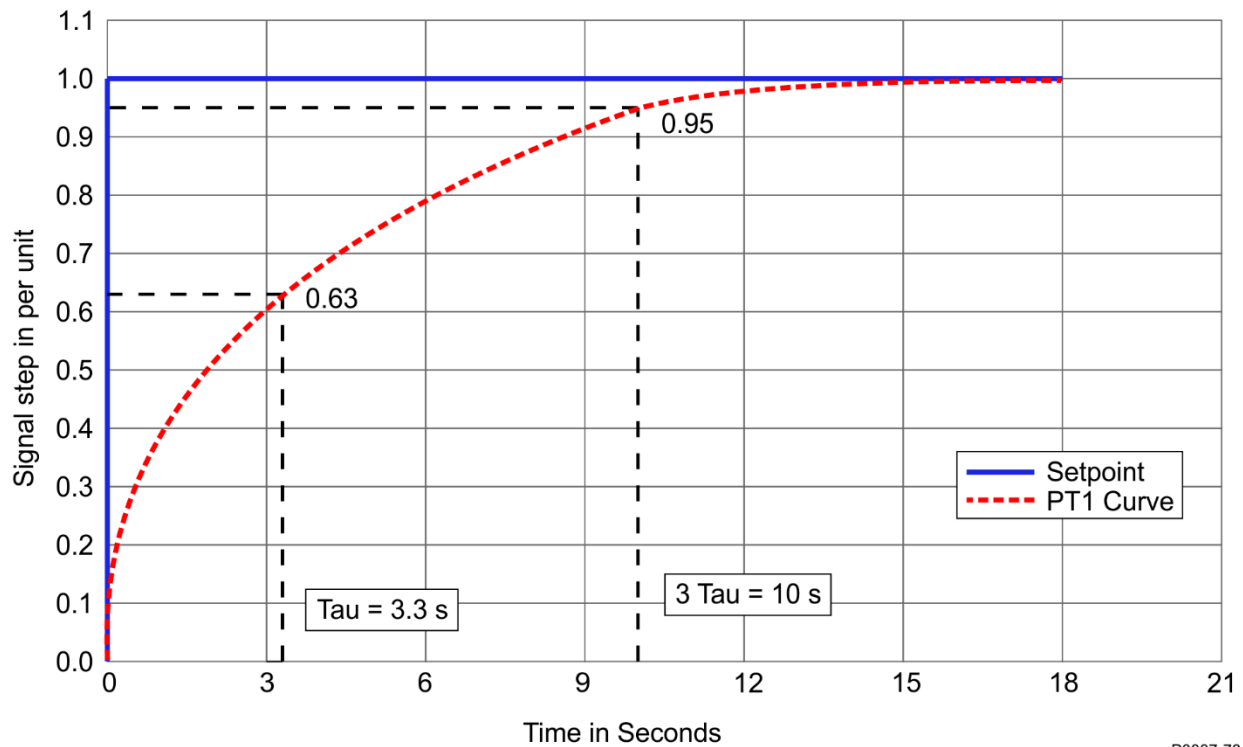
Five reactive power control modes are provided:

1. Reactive power, voltage characteristic – Q(U)
2. Characteristic curve reactive power as a function of the active power – Q(P)
3. Reactive power with voltage limiting function – Q(Voltage Limit)
4. Displacement factor cos. (power factor) – Q(PF)
5. Fixed W reactive power – Q(third party)

If not specified, the default control mode is power factor with a value of 1.0.

Reactive Power Control Time Response

Responses to setpoint changes in LVRT modes Q(U), Q(P), and Q(Voltage Limit) must follow the characteristic curve illustrated in Figure 10-6. The time constant is established by the PT1 Time Constant setting. When in Power Factor mode, the time can take up to 60 seconds for settling into the 5% tolerance band. The Vbus Time Constant setting establishes the time constant for the low-pass filter on the bus voltage measurement.



P0087-78

Figure 10-6. Reactive Power Control Time Response Characteristic Curve

Control Mode Changes

BESTCOMSPi+ Navigation Path: Settings Explorer, Grid Code Settings, Reactive Power Control, LVRT Configure

HMI Navigation Path: Settings, Operating Settings, Grid Code Settings, Reactive Power Control, Configure

Control modes can be changed through a setpoint change, remote communications, or switch inputs. When switching between modes Q(U), Q(P), and Q (Voltage Limited), the new setpoint must not be faster than the PT1 curve indicated above and must not be slower than four minutes.

LVRT reactive power control functionality is enabled by the LVRT Enable setting. When the input on the LVRT_DISABLE logic element is held true, LVRT functionality is disabled, even if LVRT functionality is enabled by the LVRT enable setting.

The Mode Selection setting establishes the active LVRT reactive power control mode. When an input on the LVRT_MODE_SELECT logic element is held true, the corresponding LVRT reactive power control mode becomes the active mode, overriding the mode specified by the Mode Selection setting.

LVRT Configure

Remote Control Failure

Failure Time Delay (s)
15.0

Fail Mode
Q(PF) Control

LVRT Configure

LVRT Enable
Disabled

Mode Selection
Q(PF) Control

PT1 Time Constant (s)
10.000

Vbus Time Constant (s)
10.000

Figure 10-7. Reactive Power Control, LVRT Configure Screen

Reactive Power as a Function of Voltage - Q(U)

BESTCOMSPlus Navigation Path: Settings Explorer, Grid Code Settings, Reactive Power Control, Q(U)

HMI Navigation Path: Settings, Operating Settings, Grid Code Settings, Reactive Power Control, Q(U) Settings

In this mode the reactive power output of the machine is adjusted as Grid Voltage fluctuates. The curve is specified by a slope which goes through the point $U = 1.00$ along with a Maximum Reactive Power setting and a Minimum Reactive Power settings both of which are in per unit.

The slope is derived from two points determined by the grid operator at the time of commissioning. The first point is the reference voltage $U_{Q0, ref} / U_C$, at which reactive power output is 0. The second point is $(U_{MAX} / U_C, Q_{MAX} \text{ under-excited} / P_{b inst})$. The slope of the characteristic m is calculated according to:

$$\text{Slope } m = (Q_{MAX} \text{ under-excited} / P_{b inst}) / (U_{MAX} / U_C - U_{Q0, ref} / U_C)$$

Equation 10-1. Slope

The slope of the characteristic must be in a range of 5 to 16.5. Unless specified, the default values for these parameters are:

$$(U_{MAX} / U_C, Q_{MAX} \text{ under-excited} / P_{b inst}) = (1.04, 0.33) \text{ and } U_{Q0, ref} / U_C = 1.00$$

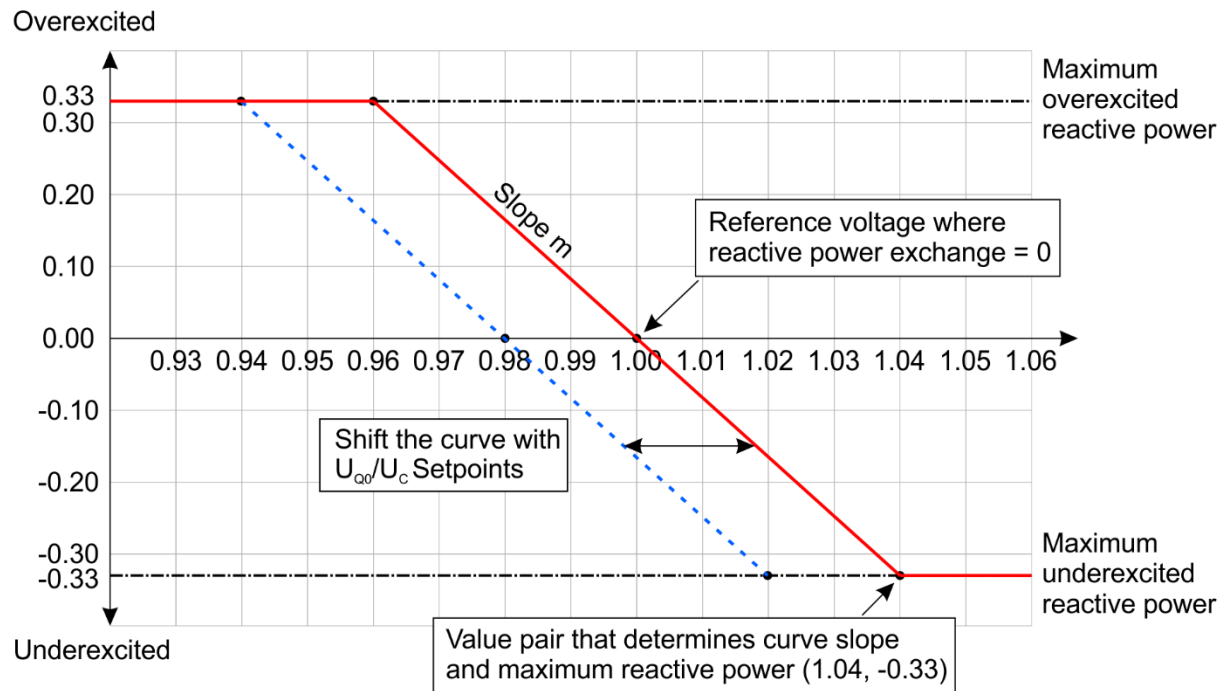
Equation 10-2. Default Values for Slope Equation

The value for the Max Reactive Power setting is equal to $Q_{MAX} \text{ under-excited} / P_{b inst}$ from the point $(U_{MAX} / U_C, Q_{MAX} \text{ under-excited} / P_{b inst})$. The value of the Min Reactive Power setting is equal to the negative of the Max Reactive Power setting.

The voltage at the grid connection point may be averaged or filtered.

There is a voltage dead band adjustable from 0.00 to 0.05 per unit in increments of 0.001 per unit. The default is zero. When the voltage goes outside the dead band, a new setpoint is calculated from the characteristic itself or the intersection of the measured mains voltage and the exceeded dead band limit.

There is also an operating setpoint (U_{Q0} / U_C) which is the operating voltage at which reactive power output will be zero. The operating setpoint is typically a fixed value but may be remotely adjusted in steps of 0.5% U_C . Such adjustment results in a horizontal shift of the characteristic (see Figure 10-8). The ability to remotely modify the setpoint is specified by the network operator at the time of system planning.



P0087-79

Figure 10-8. Reactive Power Q(U) Characteristic Curve

In the event of a remote communications failure while in Q(U) mode, the controller may continue operating in Q(U) mode using the last valid value for U_{q0}/U_c received over communications, or switch to Q(PF) operation with a PF of 1.0. The network operator may also arrange a switch to one of the other Reactive Power control modes instead.

Adjustment Sources

The Q(U) setpoint may be adjusted by the DECS-150 auxiliary input or via remote communication (Modbus®). For all adjustment sources, the value of the Q(U) Gain setting is applied to the value read from the selected input. Refer to the *Modbus Communication* section for more information on adjusting the setpoint via remote communication.

Auxiliary Input

To use the DECS-150 auxiliary input as the Q(U) adjustment source, make the following settings:

- On the Auxiliary Input screen, set the Input Function setting to Grid Code Input. Refer to the *Auxiliary Control* section for details.
- On the Active Power Control screen, set the Adjust Source setting to Auxiliary Input.

Refer to the *Auxiliary Control* section for details on how the auxiliary voltage (V_{aux}) is calculated.

V_{aux} is multiplied by 0.01 and the value of the Q(U) Gain setting:
 $(APC\ Adjust = V_{aux} \times 0.01 \times Q(U)\ Gain)$.

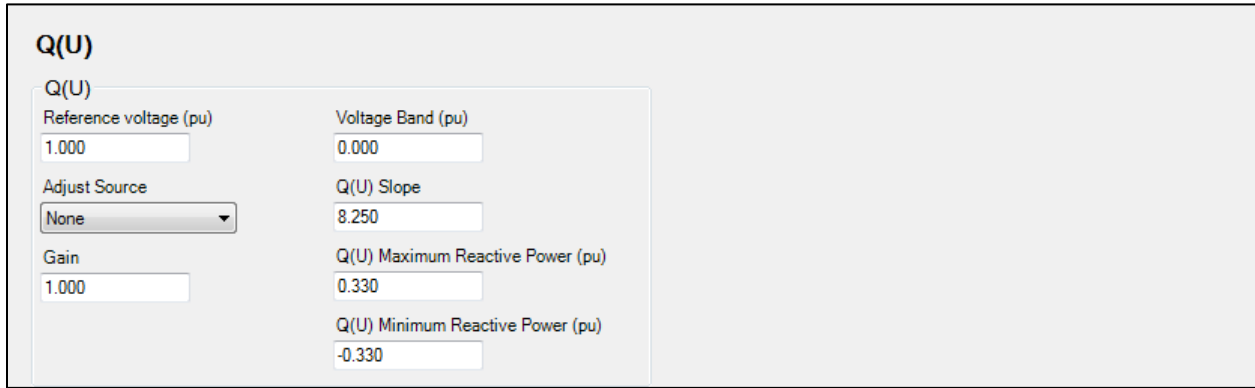


Figure 10-9. Reactive Power Control, Q(U) Screen

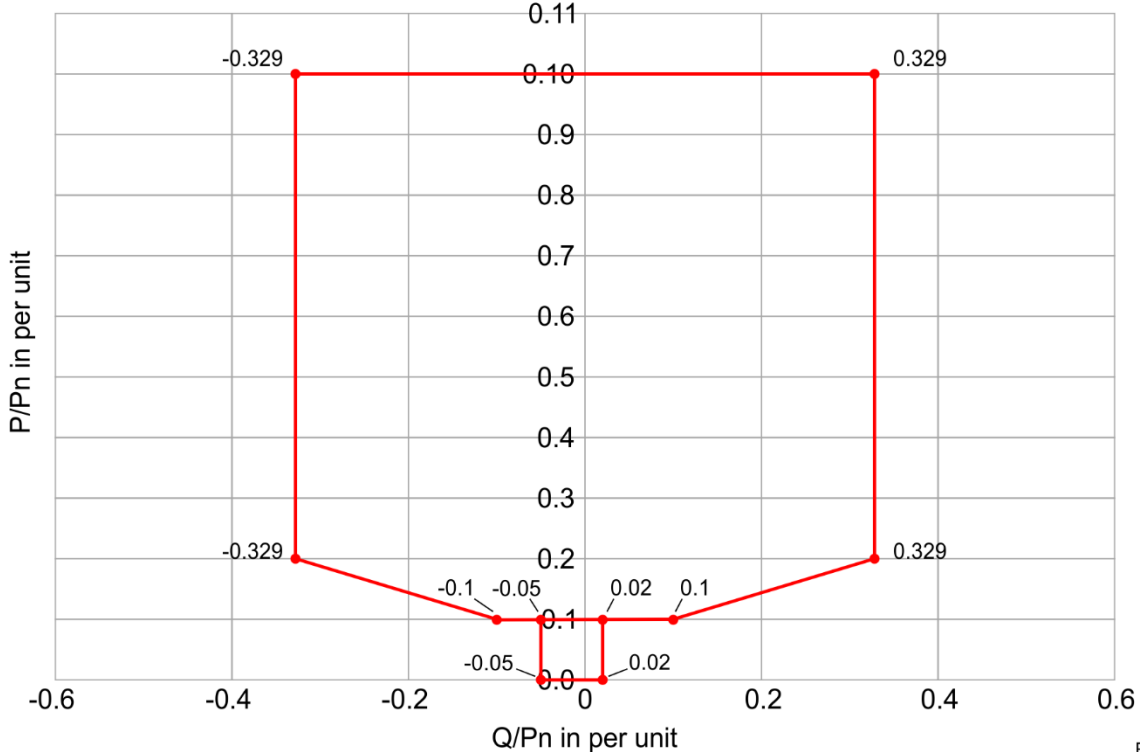
Reactive Power as a Function of Active Power – Q(P)

BESTCOMSPlus Navigation Path: Settings Explorer, Grid Code Settings, Reactive Power Control, Q(P)

HMI Navigation Path: Settings, Operating Settings, Grid Code Settings, Reactive Power Control, Q(P) Settings

In this mode the reactive power output of the machine is adjusted as the real power output fluctuates ($Q = f(P)$).

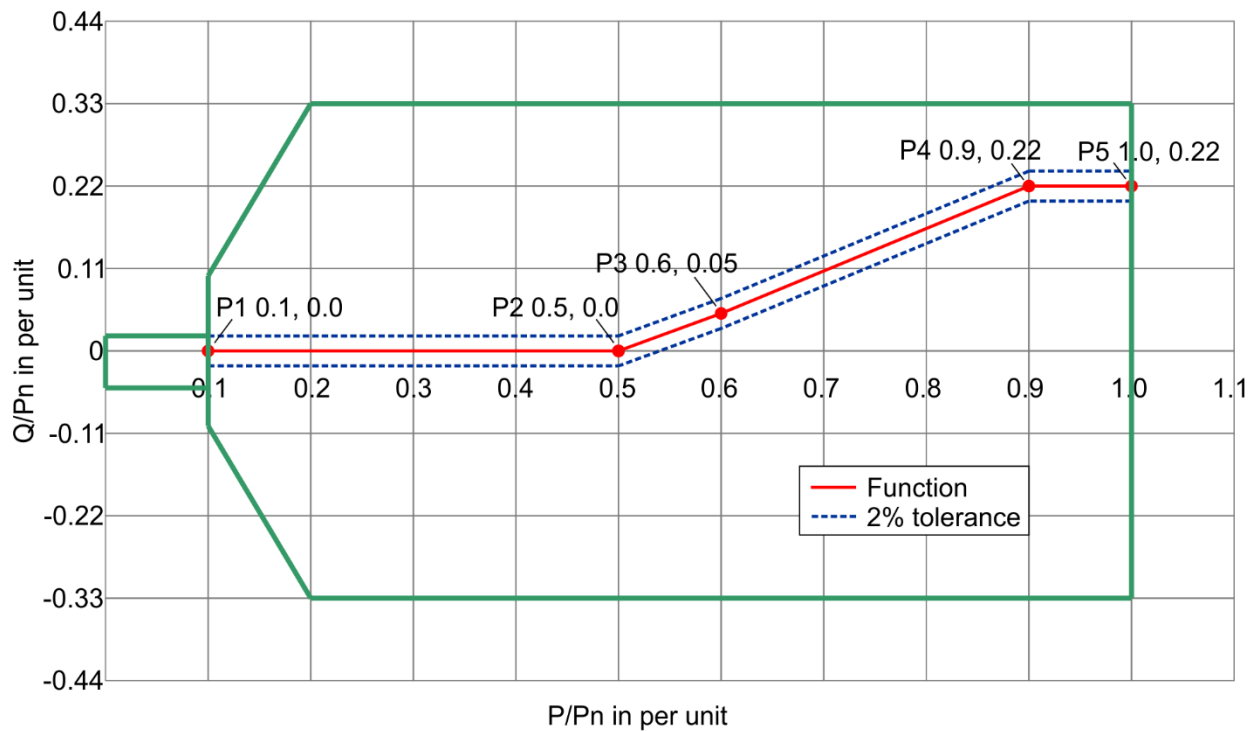
A filter time constant setting is available for the measured power level. The characteristic curve is specified by up to 10 points relating desired Q output to exported power. Perform linear interpolation between the points. The active power coordinate for each point may range from 10% to 100% active power and the range for the reactive power level must conform to Figure 10-10, below. Above 20% active power, the reactive power range should be -0.33 to 0.33 per unit reactive power.



P0087-80

Figure 10-10. Q(P) Characteristic Curve

Figure 10-11 illustrates an example characteristic with five plotted points.



P0087-81

Figure 10-11. Q(P) Characteristic Curve Example

The network operator defines the characteristic curve during network planning. Remote setpoint adjustment is not provided. However, it is possible to switch from this mode to another reactive power control mode at any time through logic. Logic can also be set to switch reactive power control modes upon a remote communications failure. Figure 10-12 illustrates the LVRT Mode Select logic element. See the *BESTlogicPlus* section for details.

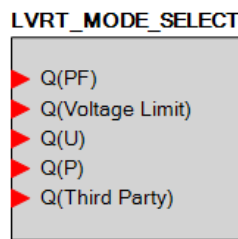


Figure 10-12. LVRT Mode Select Logic Element

If LVRT Mode is enabled, but no operating mode is specified, the default operating mode will be Power Factor with a power factor setting of 1.0.

Q(P)

Q(P)

P(k)	Q(k)	Q(P) Time Constant (s)
Point 1 (pu) 0.000	Point 1 (pu) 0.000	10.000
Point 2 (pu) 0.500	Point 2 (pu) 0.000	
Point 3 (pu) 0.600	Point 3 (pu) 0.050	
Point 4 (pu) 0.900	Point 4 (pu) 0.330	
Point 5 (pu) 1.000	Point 5 (pu) 0.330	
Point 6 (pu) 1.000	Point 6 (pu) 0.330	
Point 7 (pu) 1.000	Point 7 (pu) 0.330	
Point 8 (pu) 1.000	Point 8 (pu) 0.330	
Point 9 (pu) 1.000	Point 9 (pu) 0.330	
Point 10 (pu) 1.000	Point 10 (pu) 0.330	

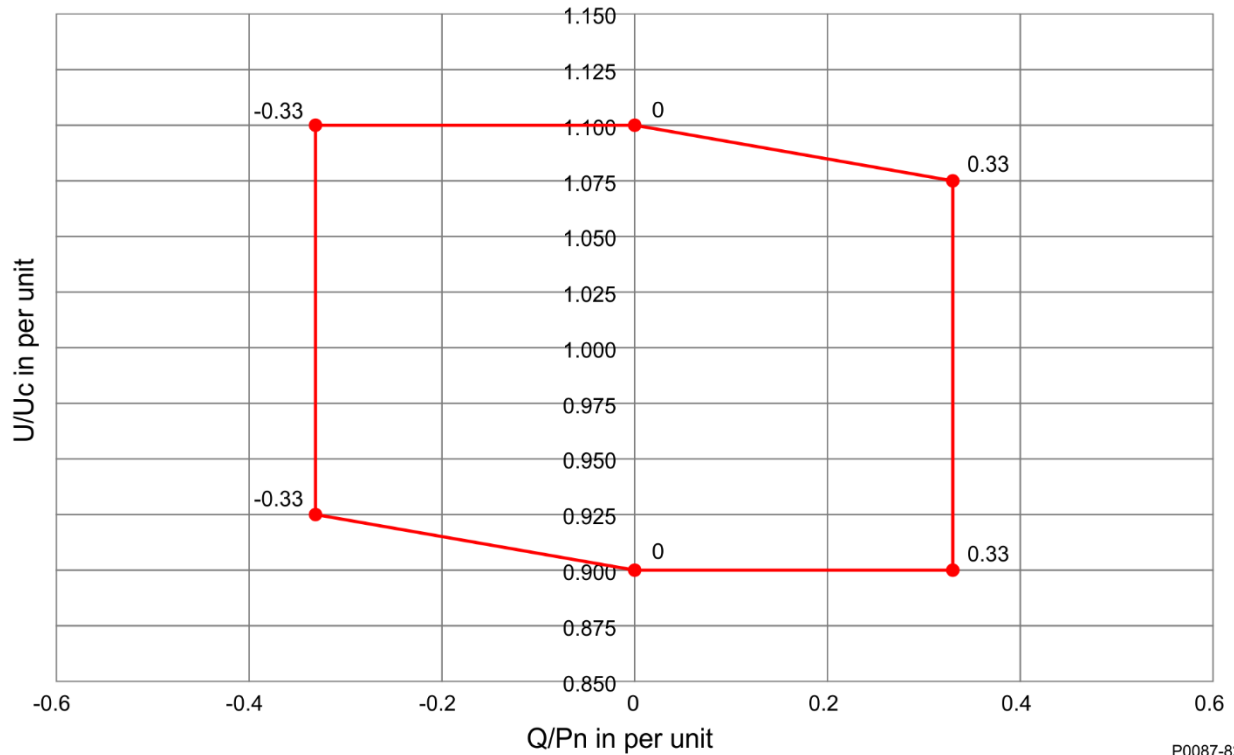
Figure 10-13. Reactive Power Control, Q(P) Screen

Reactive Power Control with Fixed Q and Voltage Limits – Q(Voltage Limit)

BESTCOMSPlus Navigation Path: Settings Explorer, Grid Code Settings, Reactive Power Control, Q(Voltage Limit)

HMI Navigation Path: Settings, Operating Settings, Grid Code Settings, Reactive Power Control, Q Limited Settings

In Q(Voltage Limit) mode, the reactive power output of the generating unit is a constant. However, it is required that the voltage and reactive power stay within the limits of the voltage dependent provision of reactive power as illustrated in Figure 10-14. This is accomplished by imposing voltage dependent limits on the reactive power output that can be achieved.



P0087-82

Figure 10-14. Q(Voltage Limit) Voltage Dependent Provision of Reactive Power

The characteristic curve consists of four points (denoted P1, P2, P3, and P4) with coordinates of per unit voltage and per unit reactive power. The points and slopes of the characteristic are as follows:

P1: (U_{p1}/U_c ; Q_{p1}/P_{binst})

P2: (U_{p2}/U_c ; Q_{ref}/P_{binst})

The slope of the characteristic curve section $m_A = (Q_{p1}/P_{binst} - Q_{ref}/P_{binst}) / (U_{p1}/U_c - U_{p2}/U_c)$;

P3: (U_{p3}/U_c ; Q_{ref}/P_{binst}),

P4: (U_{p4}/U_c ; Q_{p4}/P_{binst})

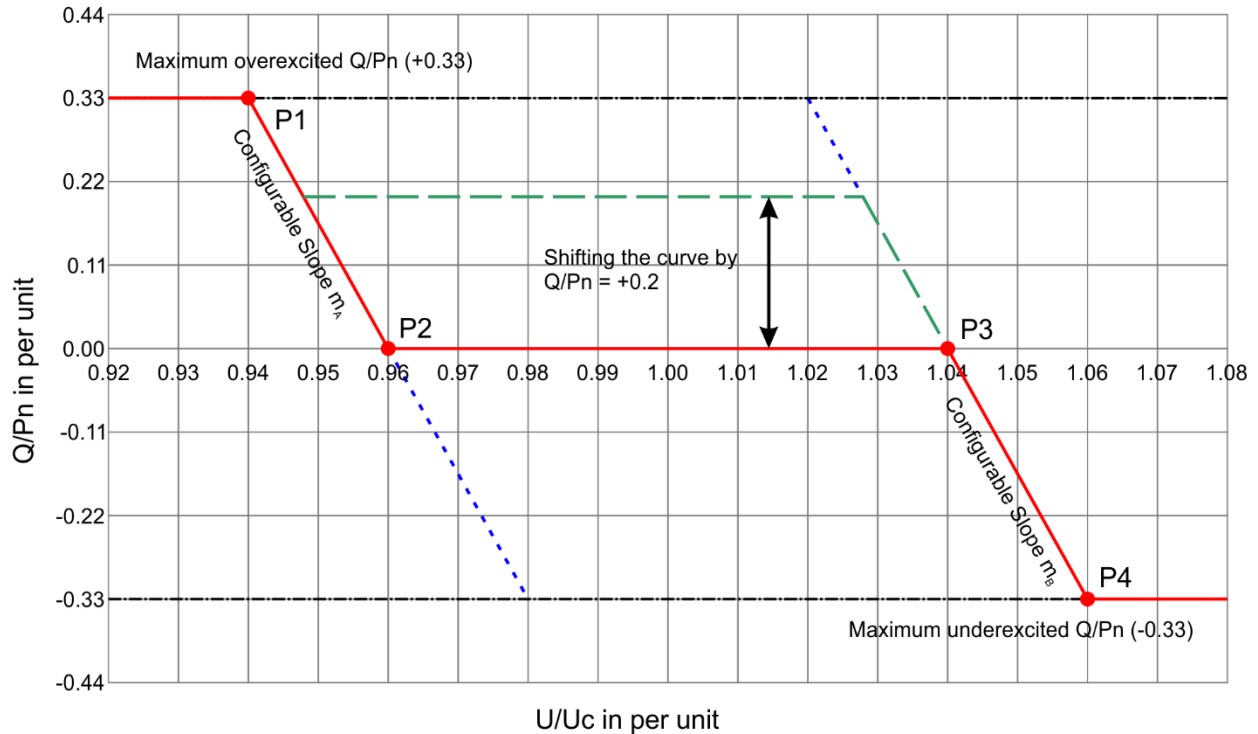
The slope of the characteristic curve section $m_B = (Q_{ref}/P_{binst} - Q_{p4}/P_{binst}) / (U_{p3}/U_c - U_{p2}/U_c)$;

To help ensure stability, gradients greater than $m=24$ are not permitted.

The network operator specifies the four points when the installation is planned. Unless specified by the network operator, the following value pairs apply:

P1 (0.94; 0.33), P2 (0.96;0), P3(1.04; 0), P4 (1.06, -0.33)

An example characteristic is shown in Figure 10-15.



P0087-83

Figure 10-15. Q(Voltage Limit) Curve Example

The reactive power value ($Q_{ref}/P_b \text{ inst}$) can be adjusted in steps of 1% ($P_b \text{ inst}$) but the range of the characteristic curve between P2 and P3 must take into account the gradients m_A and m_B . The parameter may be modified by a setting change or through remote communication. The network operator determines the availability of remote setpoint adjustment in the planning phase.

After modification of the value ($Q_{ref}/P_b \text{ inst}$), the machine output must achieve the specified output level within a maximum of four minutes.

Adjustment Sources

The Q(Voltage Limit) setpoint may be adjusted by the DECS-150 auxiliary input or via remote communication (Modbus®). For all adjustment sources, the value of the Q(Voltage Limit) Gain setting is applied to the value read from the selected input. Refer to the *Modbus Communication* section for more information on adjusting the setpoint via remote communication.

Auxiliary Input

To use the DECS-150 auxiliary input as the Q(Voltage Limit) adjustment source, make the following settings:

- On the Auxiliary Input screen, set the Input Function setting to Grid Code Input. Refer to the *Auxiliary Control* section for details.
- On the Active Power Control screen, set the Adjust Source setting to Auxiliary Input.

Refer to the *Auxiliary Control* section for details on how the auxiliary voltage (V_{aux}) is calculated.

V_{aux} is multiplied by 0.01 and the value of the Q(Voltage Limit) Gain setting:
 $(APC \text{ Adjust} = V_{aux} \times 0.01 \times Q(\text{Voltage Limit}) \text{ Gain})$.

Q(Voltage Limit)		
Q(Voltage Limit)		
Q Bias (pu)	U(k)	Q(k)
0.000	Point 1 (pu)	Point 1 (pu)
Adjust Source	0.940	0.330
None	Point 2 (pu)	Point 2 (pu)
Gain	0.960	0.000
1.000	Point 3 (pu)	Point 3 (pu)
	1.040	0.000
	Point 4 (pu)	Point 4 (pu)
	1.060	-0.330

Figure 10-16. Reactive Power Control, Q(Voltage Limit) Screen

Reactive Power Control with Fixed Power Factor – Q(PF)

BESTCOMSPPlus Navigation Path: Settings Explorer, Grid Code Settings, Reactive Power Control, Q(PF)

HMI Navigation Path: Settings, Operating Settings, Grid Code Settings, Reactive Power Control, Q(PF) Settings

In Q(PF) mode, the reactive power output must be controlled to a level that maintains a constant ratio of reactive power to apparent power to be fed to the grid. In other words, power factor at the grid connection point must be constant. The grid operator specifies the power factor setpoint. If no setpoint is specified, the default power factor shall be 1.0. This setting has a step width of 0.005. The required regulation accuracy is 2% for plants with less than 2 MW output and 4% for plants with greater than 4 MW output.

Q(PF) Adjustment.

In the DECS-150, power factor is defined such that it is positive when reactive power is exported and negative when reactive power is imported. When $PF = 1.0$, or -1.0 , the power is pure real power so Reactive Power = 0. A positive adjustment increases reactive power input and/or reduces reactive power input. A negative adjustment reduces reactive power export and/or increases reactive power export. See Figure 10-17.

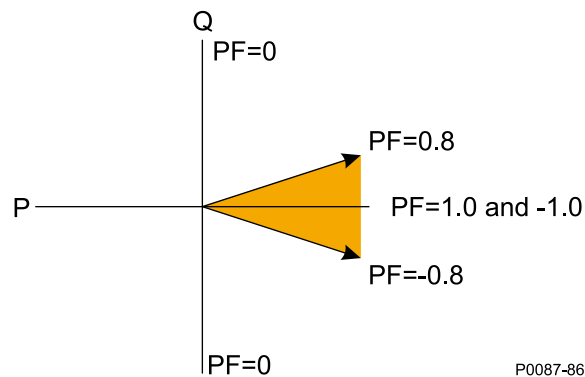


Figure 10-17. Preferable PF Region for Operating Machines

When the power factor is positive, reactive power is being exported. Applying an adjustment results in the following:

1. Application of a positive adjustment results in an increase of exported reactive power. Thus, the power factor value will decrease or move away from $PF = 1.0$.
2. Application of a negative adjustment results in a decrease of exported reactive power. Thus, the power factor value will increase or move toward $PF = 1.0$.

See Figure 10-18.

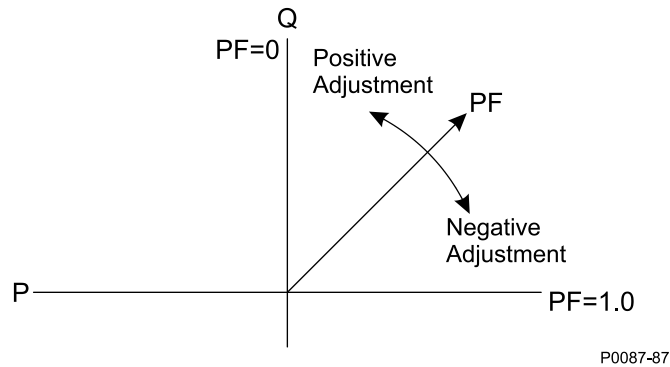


Figure 10-18. Power Factor: Positive

When the power factor is negative, reactive power is being imported. Applying an adjustment results in the following:

1. Application of a positive adjustment results in a decrease of imported reactive power. Thus, the power factor value will decrease (become more negative) or move toward $PF = -1.0$.
2. Application of a negative adjustment results in an increase of imported reactive power. Thus, the power factor value will increase (become less negative) or move away from $PF = -1.0$.

See Figure 10-19.

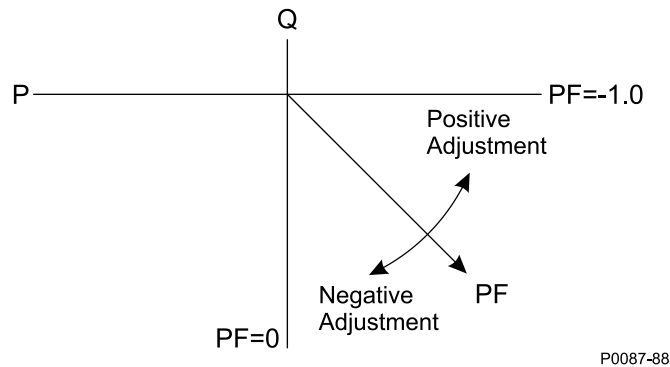


Figure 10-19. Power Factor: Negative

Adjustment Sources

The Q(PF) setpoint may be adjusted by the DECS-150 auxiliary input, or via remote communication (Modbus®). For all adjustment sources, the value of the Q(PF) Gain setting is applied to the value read from the selected input. Refer to the *Modbus Communication* section for more information on adjusting the setpoint via remote communication.

Auxiliary Input

To use the DECS-150 auxiliary input as the Q(PF) adjustment source, make the following settings:

- On the Auxiliary Input screen, set the Input Function setting to Grid Code Input. Refer to the *Auxiliary Control* section for details.
- On the Active Power Control screen, set the Adjust Source setting to Auxiliary Input.

Refer to the *Auxiliary Control* section for details on how the auxiliary voltage (Vaux) is calculated.

Vaux is multiplied by 0.01 and the value of the Q(PF) Gain setting:
($APC\ Adjust = Vaux \times 0.01 \times Q(PF)\ Gain$).

The screenshot shows the Q(PF) configuration screen. It contains the following fields and controls:

- Q(PF)** (Section Header)
- Q(PF)** (Text label)
- PF Setpoint** (Text label) with a value of 1.000 in a text box.
- Adjust Source** (Text label) with a dropdown menu set to None.
- Gain** (Text label) with a value of 1.000 in a text box.
- PF Active Power Level (pu)** (Text label) with a value of 0.100 in a text box.

Figure 10-20. Reactive Power Control, Q(PF) Screen

Reactive Power Control with Fixed Q – Q(Third Party)

BESTCOMSPlus Navigation Path: Settings Explorer, Grid Code Settings, Reactive Power Control, Q(Third Party)

HMI Navigation Path: Settings, Operating Settings, Grid Code Settings, Reactive Power Control, Q Third Party

This mode provides fixed reactive power output for instances where an external controller, outside of the DECS-150, performs the reactive power control and feeds a reactive power setpoint to the DECS-150. The PT1 time characteristic is applied in this mode, as it is in all the other modes.

Adjustment Sources

The Q(Third Party) setpoint may be adjusted by the DECS-150 auxiliary input or via remote communication (Modbus®). For all adjustment sources, the value of the Q(Third Party) Gain setting is applied to the value read from the selected input. Refer to the *Modbus Communication* section for more information on adjusting the setpoint via remote communication.

Auxiliary Input

To use the DECS-150 auxiliary input as the Q(Third Party) adjustment source, make the following settings:

- On the Auxiliary Input screen, set the Input Function setting to Grid Code Input. Refer to the *Auxiliary Control* section for details.
- On the Active Power Control screen, set the Adjust Source setting to Auxiliary Input.

Refer to the *Auxiliary Control* section for details on how the auxiliary voltage (Vaux) is calculated.

Vaux is multiplied by 0.01 and the value of the Q(Third Party) Gain setting:
($APC\ Adjust = Vaux \times 0.01 \times Q(Third\ Party)\ Gain$).

Q(Third Party)

Q(Third Party)
Q Reference (pu)
0.000

Adjust Source
None

Gain
1.000

Bridge Enable
Disabled

Figure 10-21. Reactive Power Control, Q(Third Party) Screen

Remote Communications

A communication timer is used to assess whether Modbus communication has failed. The timer constantly counts and any time the adjust setting is written, the timer is reset to zero. The Failure Time Delay setting is located on LVRT Configure screen.

If the Modbus timer counts up to the value of the Failure Time Delay setting and the Adjust Source is set to Modbus, an Active Power Control Remote Communications Failure occurs.

Remote Communication Failure

Remote communications failures are recorded in the logs and made available in *BESTlogicPlus* via the appropriate APC or LVRT Comm Fail status input. Refer to the *BESTlogicPlus* section for details. A remote communications failure has no preset effect on APC or LVRT operation. However, the APC or LVRT Comm Fail status inputs may be used with the Freeze APC Output or Freeze LVRT Output logic elements to freeze the output of the APC or LVRT PID controllers if desired.

In the event of an LVRT remote communications failure, system behavior is determined by the LVRT Failure Mode setting. The two modes of operation are:

1. Hold Q Value: When selected, the desired reactive power (Q) level determined by LVRT is frozen.
2. Q(PF): When selected, the system switches to fixed power factor operation.

Setpoints

Reactive Power Control Mode

In any reactive power control mode, other than Q(P), each setpoint is programmable through a setting or remote communication. The setpoint can be set through *BESTCOMSPPlus*, the front panel, or Modbus. In addition, each setpoint may be biased through an analog input in the DECS-150.

Setpoints are calculated as the sum of the user setting value and an adjustment offset received from remote communications. In modes Q(U), Q(Voltage Limit), Q(PF), and Q(Third Party), the Adjust Source setting allows selection of the adjustment source. The selections are: None, Auxiliary Input, or Modbus. A Gain setting specifies the gain to be applied to the DECS-150 auxiliary analog input value to achieve the desired adjustment value.

Grid Code Test

BESTCOMSPPlus Navigation Path: Settings Explorer, Grid Code Settings, Grid Code Test

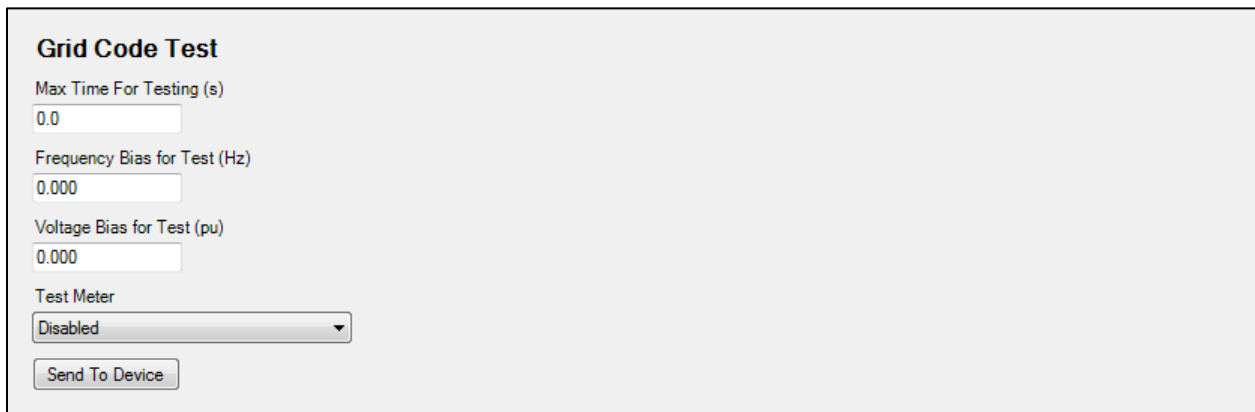
HMI Navigation Path: Not available via HMI

Grid Code Test settings provide a means to artificially bias measured grid voltage and frequency for testing grid code functionality.

The values of the Frequency Bias and Voltage Bias settings bias the measured grid frequency and voltage. These biases become active when the Send to Device button is clicked.

The Test Meter setting establishes which signal will be recorded in the Analysis (real time monitor) screen when Grid Code Test Signal is the selected test parameter.

The duration of the grid code test is established by the Max Time For Testing setting. This timer begins when the Send to Device button is clicked. When the timer expires, the frequency and voltage biases are no longer applied.



The screenshot shows a configuration window titled "Grid Code Test". It contains the following elements:

- Max Time For Testing (s)**: A text input field containing the value "0.0".
- Frequency Bias for Test (Hz)**: A text input field containing the value "0.000".
- Voltage Bias for Test (pu)**: A text input field containing the value "0.000".
- Test Meter**: A dropdown menu currently set to "Disabled".
- Send To Device**: A button located at the bottom of the form.

Figure 10-22. Grid Code Test Screen



11 • Metering

The DECS-150 provides comprehensive metering of internal and system conditions. These capabilities include extensive parameter metering, status indication, reporting, and real-time metering analysis.

BESTCOMSPPlus® Metering Explorer

DECS-150 metering is accessed through the BESTCOMSPPlus® metering explorer. The metering explorer is located in the upper left portion of the application window.

Note

BESTCOMSPPlus metering is not available when the DECS-150 is powered through the USB port when no operating power is applied.

Metering Screen Docking

A docking feature within the metering explorer allows arrangement and docking of multiple metering screens. Clicking and dragging a metering screen tab displays a blue, transparent square, several arrow boxes, and a tab box. These docking elements are illustrated in Figure 11-1.

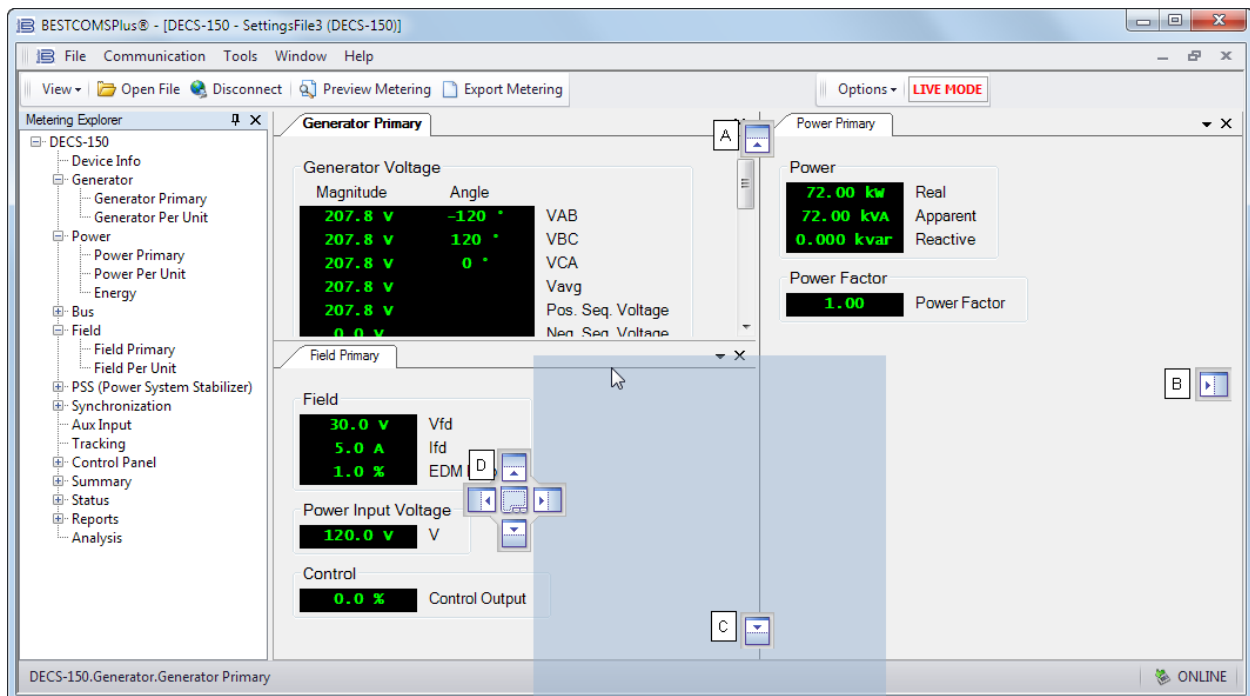


Figure 11-1. Metering Screen Docking Controls

Dragging the blue square to the “up” (locator A), “right” (locator B), or “down” (locator C) arrow box places the selected metering screen across the top, along the side, or at the bottom of the window. Once placed, the screen’s thumbtack icon can be clicked to dock the screen on the corresponding top, right, or lower bar. A docked screen is viewed by hovering the mouse pointer over the docked screen.

Dragging the blue square to one of the four arrow boxes (locator D) places the screen inside the selected window according to the arrow box selected. A metering screen can be placed as a tab inside the selected window by dropping the screen on the tab box at the center of the four arrow boxes.

Dragging the blue square anywhere other than one of the arrow/tab boxes places the selected metering screen as a floating window. Double-click near the top of the screen to dock.

Metered Parameters

DECS-150 metering categories include generator/motor, power, bus, field, power system stabilizer (PSS), and generator synchronization parameters.

Generator/Motor

BESTCOMSPlus Navigation Path: Metering Explorer, Generator/Motor

Metered machine parameters include the voltage (magnitude and angle), current (magnitude and angle), and frequency. Primary- and per-unit values are available. Figure 11-2 illustrates the generator primary-values metering screen.

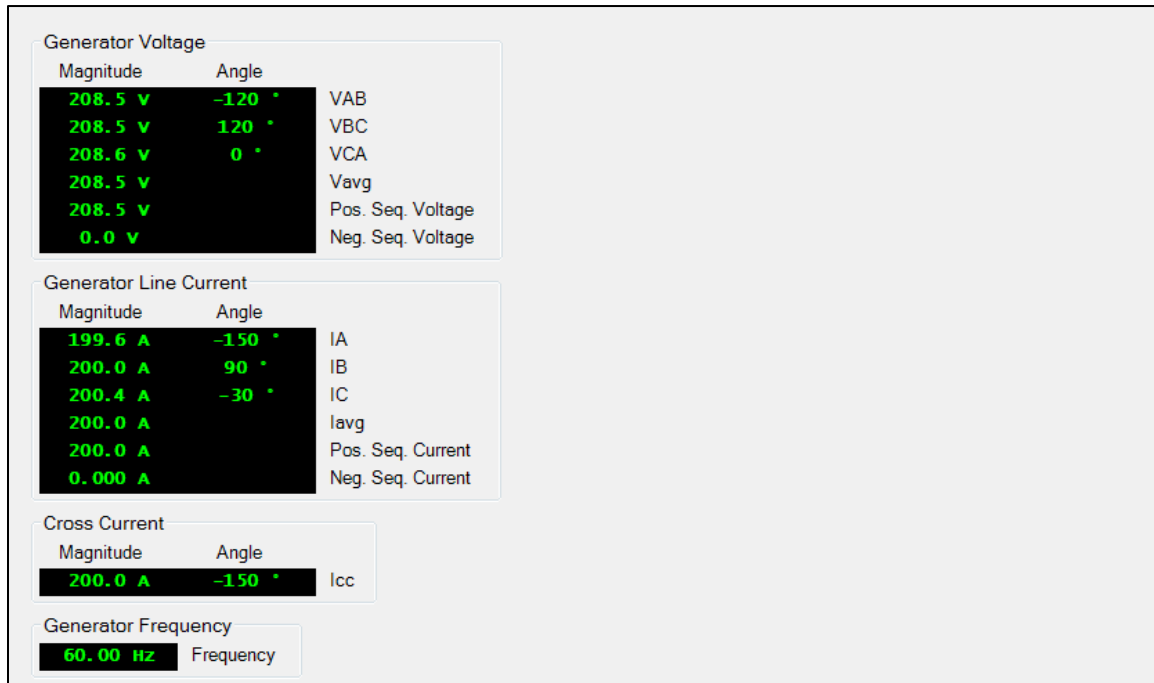


Figure 11-2. Generator Primary-Values Metering

Power

BESTCOMSPlus Navigation Path: Metering Explorer, Power

Metered power parameters include real power (kW), apparent power (kVA), reactive power (kvar), and machine power factor. Primary- and per-unit values are available. The Power Primary-Values screen is illustrated in Figure 11-3.



Figure 11-3. Power Primary-Values

Energy

Energy parameters include accumulated watthours (positive and negative kWh), varhours (positive and negative kvarh), and voltampere hours (kVAh). The Energy screen is illustrated in Figure 11-4. Click the Edit button to open the Meter Energy Editor and manually enter values.

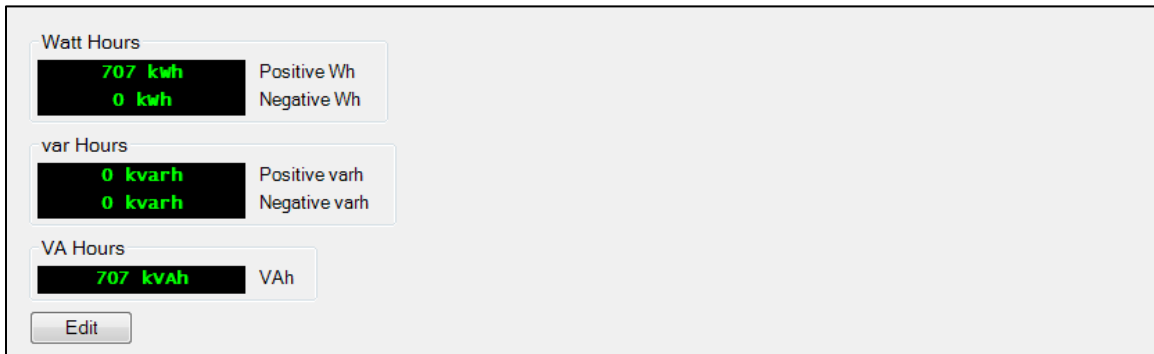


Figure 11-4. Energy

Bus

BESTCOMSPlus Navigation Path: Metering Explorer, Bus

Metered bus parameters include the voltage across phases A and B (Vab), phases B and C (Vbc), phases A and C (Vca), and the average bus voltage. The frequency of the bus voltage is also metered. Primary- and per-unit values are available. Figure 11-5 illustrates the bus primary-values metering screen.

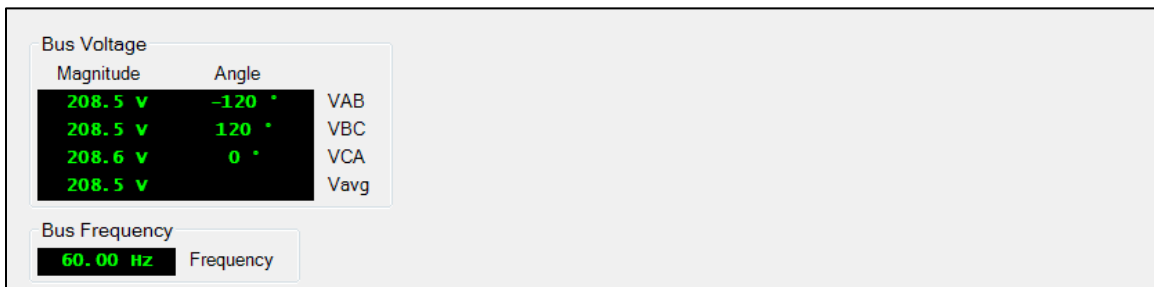


Figure 11-5. Bus Primary-Values Metering

Field

BESTCOMSPlus Navigation Path: Metering Explorer, Field

Metered field parameters include the field voltage (Vfd), current (Ifd), and exciter diode ripple current. The exciter diode ripple is reported by the exciter diode monitor (EDM) as the induced ripple in the exciter field current.

To achieve the desired level of excitation, the appropriate level of operating power input voltage must be applied. This value is displayed as the power input voltage.

The level of excitation power supplied to the field is displayed as a percentage, with 0% being the minimum and 100% being the maximum.

Primary- and per-unit values are available. Figure 11-6 illustrates the field primary-values metering screen.

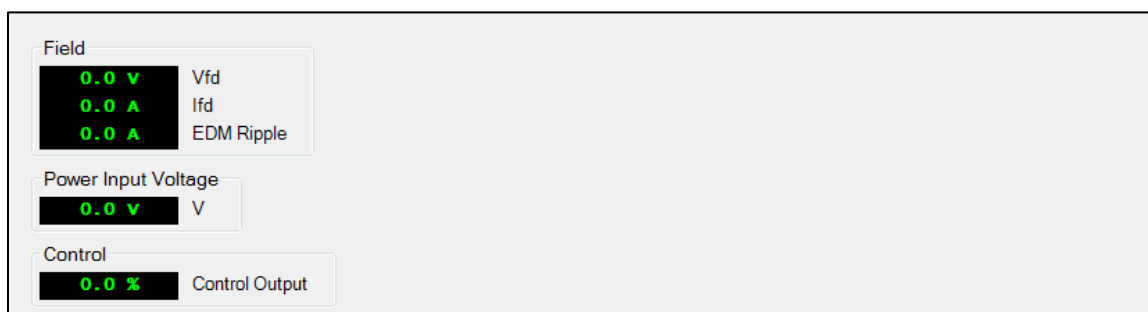


Figure 11-6. Field Primary-Values Metering

PSS

BESTCOMSPlus Navigation Path: Metering Explorer, PSS (Power System Stabilizer)

Values metered by the power system stabilizer function display positive sequence voltage and current, negative sequence voltage and current, terminal frequency deviation, compensated frequency deviation, and the per-unit PSS output level. The PSS function on/off status is also reported. Primary- and per-unit values are available. Figure 11-7 illustrates the PSS primary-values metering screen.

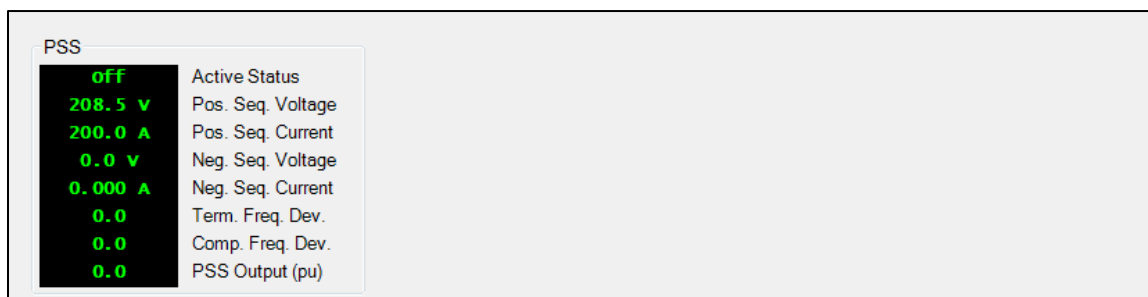


Figure 11-7. PSS Primary-Values Metering

Synchronization

BESTCOMSPlus Navigation Path: Metering Explorer, Synchronization

Metered generator-to-bus synchronization parameters include the slip frequency, slip angle, and voltage difference. Primary- and per-unit values are available. Figure 11-8 illustrates the synchronization primary-values metering screen.



Figure 11-8. Synchronization Primary-Values Metering

Auxiliary Control Input

BESTCOMSPlus Navigation Path: Metering Explorer, Aux Input

The control signal applied at the DECS-150 auxiliary control input is indicated on the Aux Input metering screen (Figure 11-9). As configured in BESTCOMSPlus®, a dc voltage or dc current signal may be applied.



Figure 11-9. Auxiliary Control Input Metering

Tracking

BESTCOMSPlus Navigation Path: Metering Explorer, Tracking

The metered setpoint tracking error between DECS-150 operating modes is displayed on the Tracking screen (Figure 11-10). Status fields are also provided for the on/off status for internal and external setpoint tracking. An additional status field indicates when the setpoint of an inactive operating mode matches the metered value.

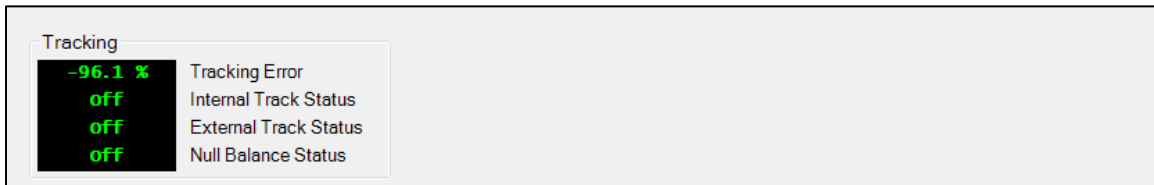


Figure 11-10. Tracking Metering

Control Panel

BESTCOMSPlus Navigation Path: Metering Explorer, Control Panel

The Control Panel (Figure 11-11) provides options for changing operating modes, selecting setpoint pre-positions, fine tuning setpoints, and toggling virtual switches. The setpoints for AVR, var, and PF are displayed, as well as Alarm status, PSS status, Null Balance status, and Grid Code Mode.

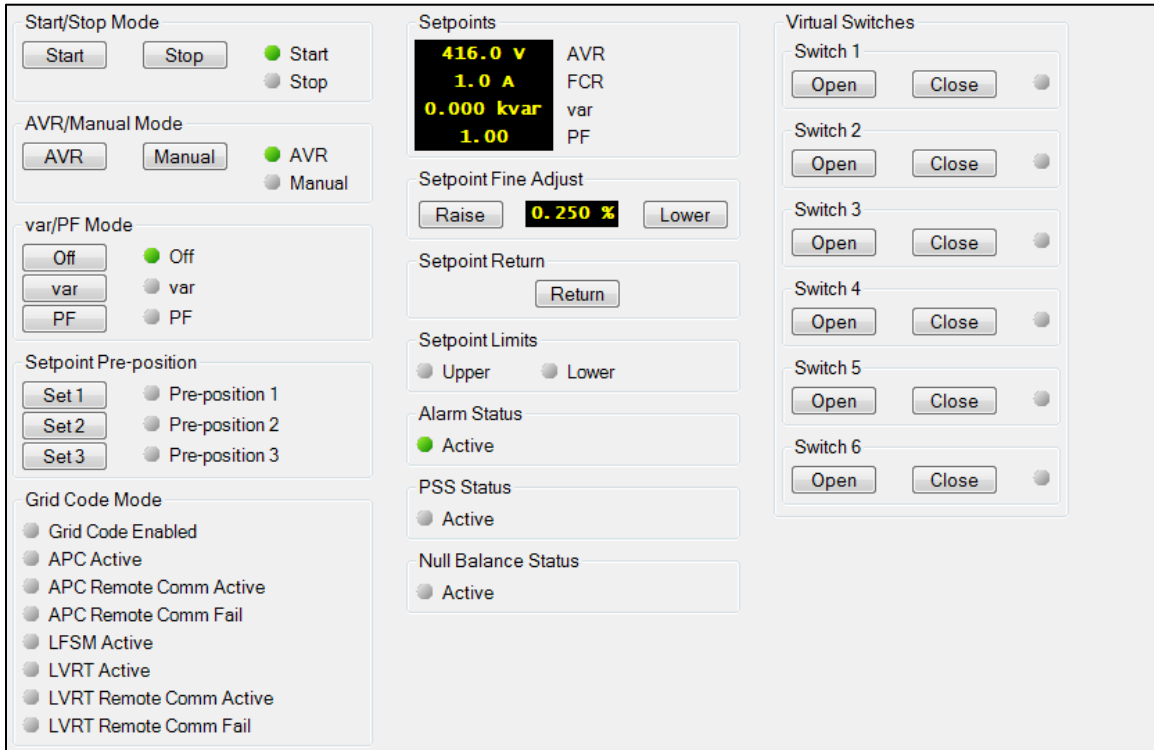


Figure 11-11. Control Panel

Start/Stop Mode: Two indicators show the start/stop mode of the DECS-150. When a mode is active, its corresponding indicator changes from gray to green. To select the DECS-150 Start status, click the Start button. Click the Stop button to select DECS-150 Stop status.

AVR/Manual Mode: AVR and Manual Mode status is reported by two indicators. When a mode is active, its corresponding indicator changes from gray to green. AVR mode is selected by clicking the AVR button and manual mode is selected by clicking the Manual button.

Var/PF Mode: Three indicators report whether var mode, Power Factor mode, or neither mode is active. When a mode is active, its corresponding indicator changes from gray to green. When neither mode is active, the Off indicator changes from gray to green. Var mode is enabled by clicking the var button and Power Factor mode is enabled by clicking the PF button. Var or power factor correction is disabled by clicking the Off button. Only one mode can be enabled at any time.

Setpoint Pre-Position: A control button and indicator are provided for the three setpoint pre-positions. Clicking the Set 1 button adjusts the excitation setpoint to the Pre-position 1 value and changes the Pre-position 1 indicator to green. Pre-positions 2 and 3 are selected by clicking the Set 2 and Set 3 buttons respectively.

Grid Code Mode: These eight indicators change from gray to green to indicate various grid code status.

Setpoints: Two status fields display the active setpoints for AVR mode, FCR mode, var mode, and Power Factor mode. These active setpoints, displayed with yellow characters, are not to be confused with metered analog values, which are displayed with green characters throughout BESTCOMSP^{Plus}. For details on operating setpoint settings, see the *Regulation* section.

Setpoint Fine Adjust: Clicking the Raise button increases the active operating setpoint. Clicking the Lower button decreases the active operating setpoint. The raise and lower increment is directly proportional to the adjustment range and inversely proportional to the traverse rate.

Setpoint Return: Clicking the Return button changes the active operating setpoint back to the original value before it was adjusted.

Setpoint Limits: The Upper indicator changes from gray to green when the upper setpoint limit threshold has been exceeded. The Lower indicator changes from gray to green when the lower setpoint limit threshold has been exceeded.

Alarm Status: The Alarm Status indicator changes from gray to green when there is an active alarm.

PSS Status: The PSS Status indicator changes from gray to green when the optional power system stabilizer is active.

Null Balance: The Null Balance indicator changes from gray to green when the setpoint of the inactive operating modes (AVR, FCR, var, or PF) match the setpoint of the active mode.

Virtual Switches: These buttons control the open or closed status of the six virtual switches. Clicking the Open button sets the switch to the open position and changes the switch indicator to gray. Clicking the Close button sets the switch to the closed position and changes the switch indicator to red. After clicking either button, you will be prompted to confirm your selection.

Metering Summary

BESTCOMSP^{Plus} Navigation Path: [Metering Explorer, Summary](#)

All of the metering values displayed on the individual, previously-described metering screens are consolidated on the metering summary screen. Primary- and per-unit values are available. Figure 11-12 illustrates the primary-values metering summary screen.

Summary			
0.0 V	VAB	17.4 V	Vfd
0.0 V	VBC	0.0 A	I _{fd}
0.0 V	VCA	0.0 A	EDM Ripple
0.0 V	Vavg	17.5 V	Power Input Voltage
---	IA	100.0 %	Control Output
0.000 A	IB	off	PSS Active Status
---	IC	0.0 V	Pos. Seq. Voltage
0.000 A	Iavg	0.000 A	Pos. Seq. Current
231 °	VI	0.0 V	Neg. Seq. Voltage
0.000 A	Icc	0.000 A	Neg. Seq. Current
---	Frequency	0.0 %	Term. Freq. Dev.
0.000 kw	Real Power	0.0 %	Comp. Freq. Dev.
0.000 kVA	Apparent Power	0.0	PSS Output (pu)
0.000 kvar	Reactive Power	0.00 Hz	Slip Frequency
1.00	PF	20 °	Slip Angle
1,599,136 kWh	Positive Wh	0.0 V	Voltage Difference
0 kWh	Negative Wh	-0.02 V	Vaux
0 kvarh	Positive varh	---	Iaux
0 kvarh	Negative varh	-96.1 %	Tracking Error
1,599,136 kVAh	VAh	off	Internal Track Status
---	Bus VAB	off	External Track Status
---	Bus VBC	off	Null Balance Status
0.0 V	Bus VCA		
0.0 V	Bus Vavg		
---	Bus Frequency		

Figure 11-12. Metering Summary Screen

Status Indication

Status indication is provided for DECS-150 system functions, inputs, outputs, network load share, grid code, configurable protection, alarms, and the real-time clock.

System Status

BESTCOMSPlus Navigation Path: Metering Explorer, Status, System Status

When any of the system functions illustrated in Figure 11-13 are active, the corresponding indicator changes from gray to green. An inactive function is represented by a gray indicator.



Figure 11-13. System Status Indication Screen

Inputs

BESTCOMSPlus Navigation Path: Metering Explorer, Status, Inputs

Status indication for the DECS-150's eight contact sensing inputs is provided on the BESTCOMSPlus contact inputs status screen illustrated in Figure 11-14. An indicator changes from gray to red when a closed contact is sensed at the corresponding input.

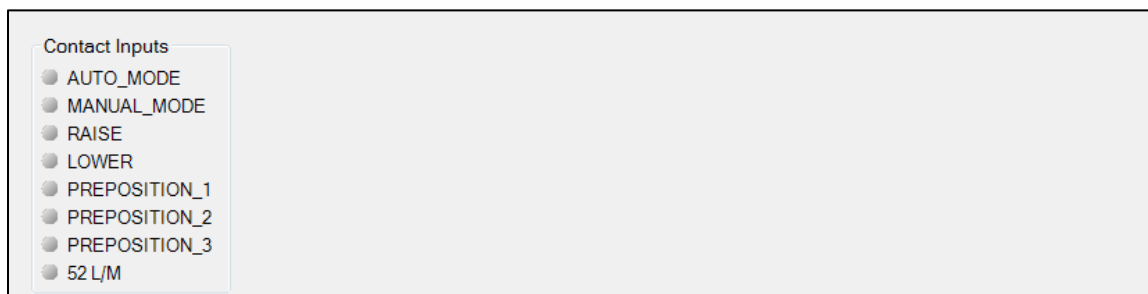


Figure 11-14. DECS-150 Contact Inputs Status Indication Screen

Outputs

BESTCOMSPlus Navigation Path: Metering Explorer, Status, Outputs

Status indication for the DECS-150's Watchdog, Breaker Shunt Trip, and two contact outputs is provided on the BESTCOMSPlus contact outputs status screen illustrated in Figure 11-15. An indicator changes from gray to green when the corresponding output changes state (Watchdog output) or closes (Outputs 1 and 2).

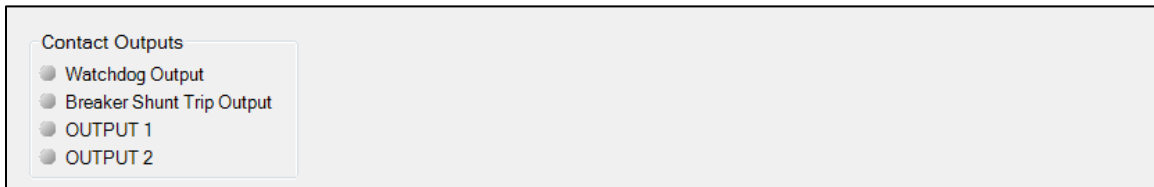


Figure 11-15. DECS-150 Contact Outputs Status Indication Screen

Network Load Share

The screen shown in Figure 11-16 reports the error percent, reactive current, NLS average reactive current, and number of generators online. The status indicators change from gray to green when a status is active.

The Error percent is the deviation of the unit's reactive current from the system average. The NLS Average Reactive Current is the average of the reactive current of every unit in the system. Generators Online is the number of units actively load sharing.

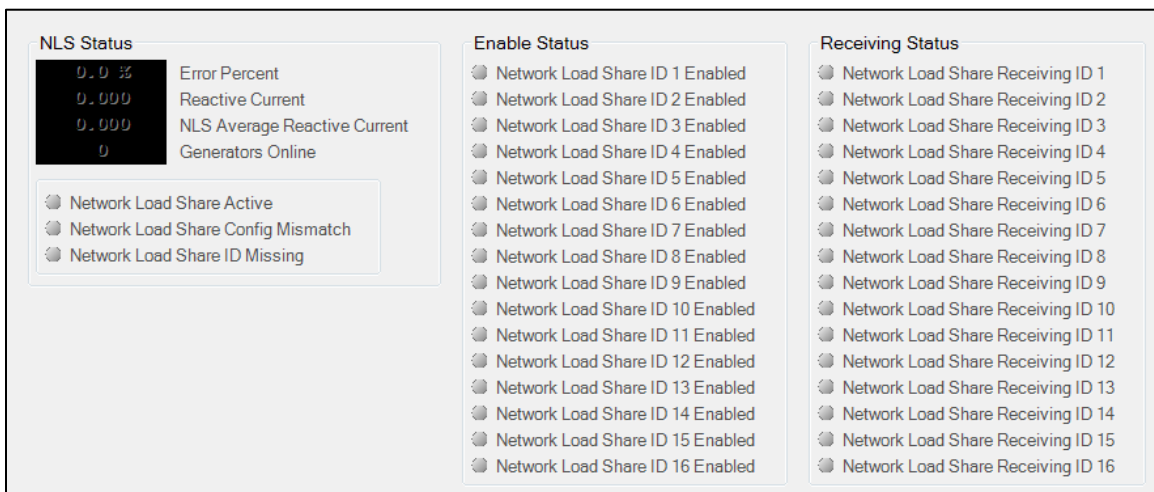


Figure 11-16. NLS Status Screen

Grid Code

BESTCOMSPlus Navigation Path: Metering Explorer, Status, Grid Code

Metering and status related to grid code is shown on this screen (Figure 11-17). Indicators change from gray to green when the status is true.

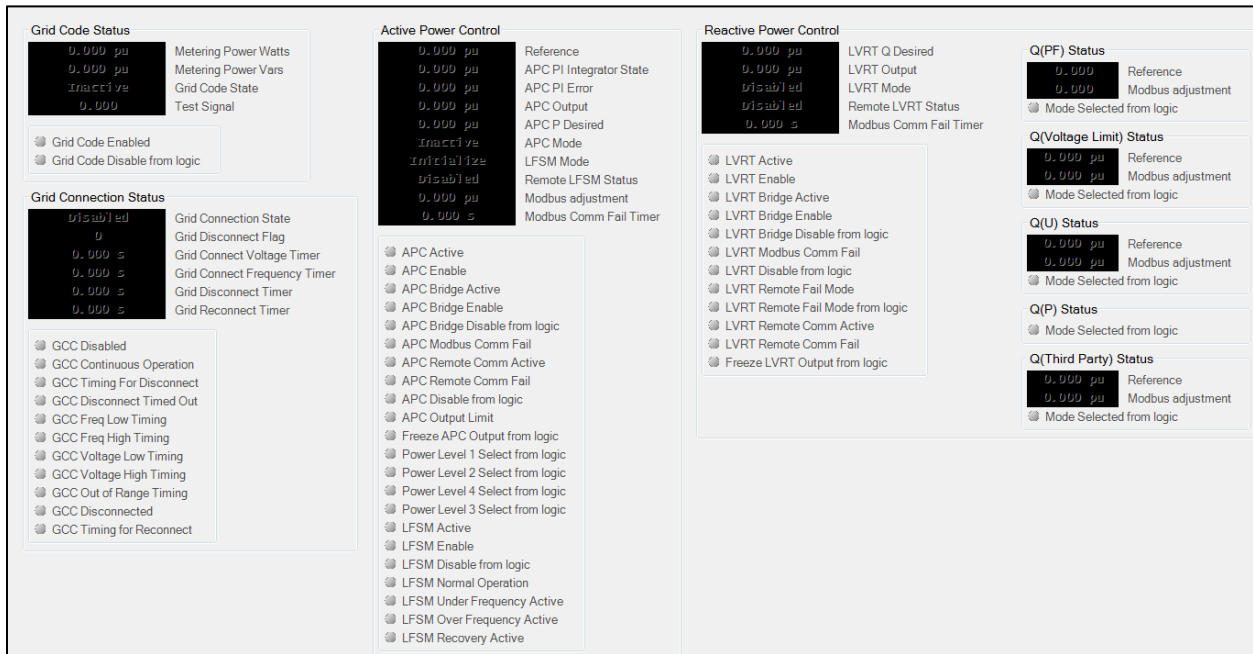


Figure 11-17. Grid Code Status Screen

Configurable Protection

BESTCOMSPPlus Navigation Path: Metering Explorer, Status, Configurable Protection

Trip status for the eight configurable, supplemental protection elements is annunciated on the BESTCOMSPPlus configurable protection screen (Figure 11-18). An indicator for each protection element’s four trip thresholds changes from gray to green when the corresponding trip threshold is exceeded.

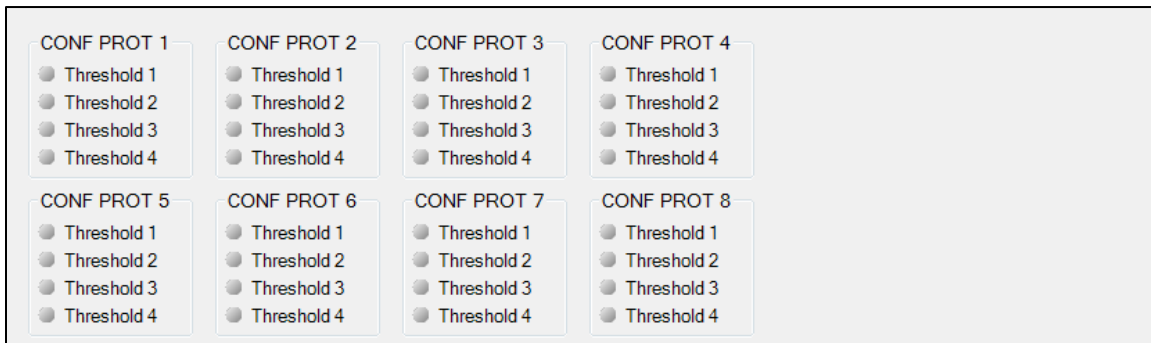


Figure 11-18. Configurable Protection Indication Status Screen

Alarms

BESTCOMSPPlus Navigation Path: Metering Explorer, Status, Alarms

System parameters, communication links, and protection functions are constantly monitored for alarm conditions. Active and previously latched alarms are listed on the Alarms screen of BESTCOMSPPlus. A Reset Alarms button on the Alarms screen is clicked to clear all inactive alarms in BESTCOMSPPlus. The BESTCOMSPPlus Alarms screen is illustrated in Figure 11-19. All possible DECS-150 alarms are listed below.



Figure 11-19. DECS-150 Alarm Annunciation and Reset Screen

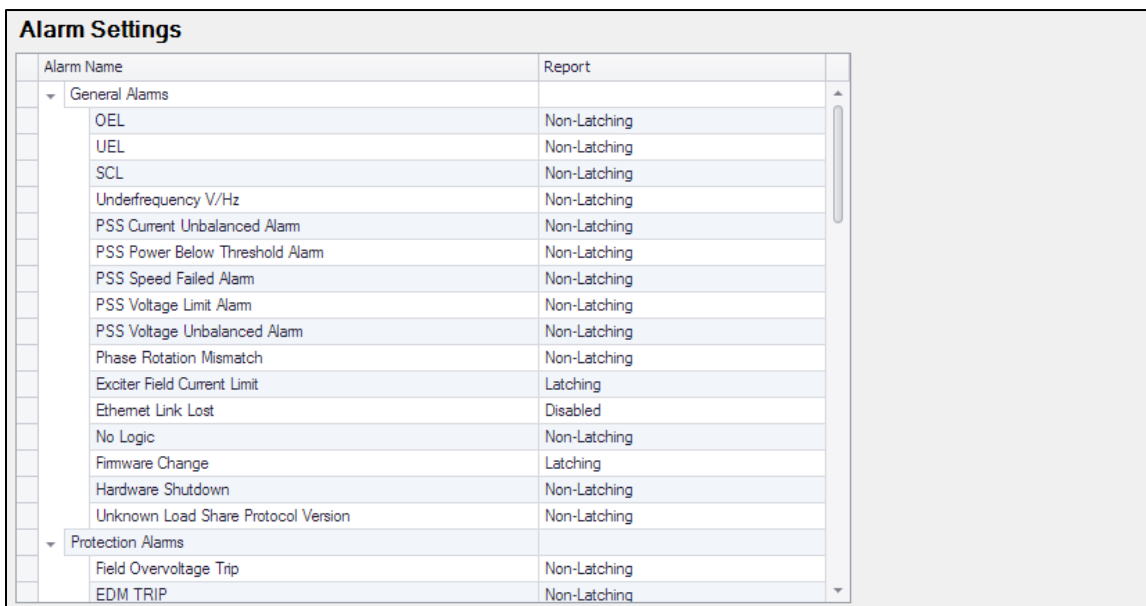
27P Trip	Ethernet Link Lost
59P Trip	Exciter Field Current Limit
81O Trip	Field Overvoltage Trip
81U Trip	Firmware Change
APC Bridge Active	GCC Disconnect Timed Out
APC Output Limit	GCC Timing for Disconnect
APC Remote Comm Fail	Generator/Motor Below 10Hz
Configurable Protection 1 Threshold 1 Trip	Hardware Shutdown
Configurable Protection 1 Threshold 2 Trip	Loss of Sensing Trip
Configurable Protection 1 Threshold 3 Trip	LVRT Bridge Active
Configurable Protection 1 Threshold 4 Trip	LVRT Remote Comm Fail
Configurable Protection 2 Threshold 1 Trip	No Logic
Configurable Protection 2 Threshold 2 Trip	OEL
Configurable Protection 2 Threshold 3 Trip	Phase Rotation Mismatch
Configurable Protection 2 Threshold 4 Trip	Power Input Failure
Configurable Protection 3 Threshold 1 Trip	Programmable Alarm 1 Name
Configurable Protection 3 Threshold 2 Trip	Programmable Alarm 10 Name
Configurable Protection 3 Threshold 3 Trip	Programmable Alarm 11 Name
Configurable Protection 3 Threshold 4 Trip	Programmable Alarm 12 Name
Configurable Protection 4 Threshold 1 Trip	Programmable Alarm 13 Name
Configurable Protection 4 Threshold 2 Trip	Programmable Alarm 14 Name
Configurable Protection 4 Threshold 3 Trip	Programmable Alarm 15 Name
Configurable Protection 4 Threshold 4 Trip	Programmable Alarm 16 Name
Configurable Protection 5 Threshold 1 Trip	Programmable Alarm 2 Name
Configurable Protection 5 Threshold 2 Trip	Programmable Alarm 3 Name
Configurable Protection 5 Threshold 3 Trip	Programmable Alarm 4 Name
Configurable Protection 5 Threshold 4 Trip	Programmable Alarm 5 Name
Configurable Protection 6 Threshold 1 Trip	Programmable Alarm 6 Name
Configurable Protection 6 Threshold 2 Trip	Programmable Alarm 7 Name
Configurable Protection 6 Threshold 2 Trip	Programmable Alarm 8 Name
Configurable Protection 6 Threshold 3 Trip	Programmable Alarm 9 Name
Configurable Protection 6 Threshold 4 Trip	PSS Current Unbalanced Alarm
Configurable Protection 7 Threshold 1 Trip	PSS Power Below Threshold Alarm
Configurable Protection 7 Threshold 2 Trip	PSS Speed Failed Alarm
Configurable Protection 7 Threshold 3 Trip	PSS Voltage Limit Alarm
Configurable Protection 7 Threshold 4 Trip	PSS Voltage Unbalanced Alarm
Configurable Protection 8 Threshold 1 Trip	SCL
Configurable Protection 8 Threshold 2 Trip	Transfer Watchdog Alarm
Configurable Protection 8 Threshold 3 Trip	UEL
Configurable Protection 8 Threshold 4 Trip	Underfrequency V/Hz
EDM Trip	Unknown Load Share Protocol Version

Alarm Configuration

BESTCOMSPlus Navigation Path: Settings Explorer, Alarm Configuration, Alarms

Alarms are configured using *BESTCOMSPlus*. Customize the reporting style of each alarm by choosing Disabled, Latching, or Non-Latching. Latching alarms are stored in nonvolatile memory and are retained even when operating power to the DECS-150 is lost. Active alarms are shown on the front panel and in *BESTCOMSPlus* until they are cleared. Non-latching alarms are cleared when operating power is removed. Disabling an alarm affects only the annunciation of the alarm and not the actual operation of the alarm. This means that the alarm will still trip when trip conditions are met and the occurrence will appear on the sequence of events reports.

The *BESTCOMSPlus* Alarm Settings screen is illustrated in Figure 11-20 below.



Alarm Name	Report
General Alarms	
OEL	Non-Latching
UEL	Non-Latching
SCL	Non-Latching
Underfrequency V/Hz	Non-Latching
PSS Current Unbalanced Alarm	Non-Latching
PSS Power Below Threshold Alarm	Non-Latching
PSS Speed Failed Alarm	Non-Latching
PSS Voltage Limit Alarm	Non-Latching
PSS Voltage Unbalanced Alarm	Non-Latching
Phase Rotation Mismatch	Non-Latching
Exciter Field Current Limit	Latching
Ethernet Link Lost	Disabled
No Logic	Non-Latching
Firmware Change	Latching
Hardware Shutdown	Non-Latching
Unknown Load Share Protocol Version	Non-Latching
Protection Alarms	
Field Overvoltage Trip	Non-Latching
EDM TRIP	Non-Latching

Figure 11-20. Alarm Settings Screen

User-Programmable Alarms

BESTCOMSPlus Navigation Path: Settings Explorer, Alarm Configuration, User Programmable Alarms

Sixteen user programmable alarms are available. User alarm labels are entered on the User Programmable Alarms screen (Figure 11-21). If the trip condition exists for the duration of the activation delay, the alarm is tripped. When active, the label of a user programmable alarm is displayed on the *BESTCOMSPlus* Alarms screen and in the sequence of events reports.

Each alarm provides a logic output that can be connected to a physical output or other logic input using *BESTlogicPlus* Programmable Logic. Refer to the *BESTlogicPlus* section for more information on setting up alarm logic.

The screenshot displays a grid of 15 'User Programmable Alarm' configuration panels. Each panel is titled 'User Programmable Alarm #X' (where X is the alarm number) and contains three input fields: 'Label Text', 'Programmable Alarm X Name', and 'Activation Delay (s)'. The 'Activation Delay' is currently set to 0 for all alarms.

Figure 11-21. User Programmable Alarms Screen

Retrieving Alarm Information

Alarms are displayed in the sequence of events reports. Certain alarm LEDs are automatically lit on the front panel display when active. Refer to the *Front Panel* section for a list of alarm LEDs on the front panel. To view active alarms using BESTCOMSP_{Plus}, use the Metering Explorer to open the Status, Alarms screen.

Resetting Alarms

A BESTlogic_{Plus} expression can be used to reset the alarms. Use the Settings Explorer within BESTCOMSP_{Plus} to open the BESTlogic_{Plus} Programmable Logic screen. Select the ALARM_RESET logic block from the list of Elements. Use the drag and drop method to connect a variable or series of variables to the *Reset* input. When this input is set true, this element resets all active alarms. Refer to the BESTlogic_{Plus} section for more information.

Real-Time Clock

BESTCOMSP_{Plus} Navigation Path: Metering Explorer, Status, Real Time Clock

The DECS-150 time and date is displayed and adjusted on the BESTCOMSP_{Plus} Real-Time Clock screen (Figure 11-22). Manual adjustment of the DECS-150 clock is made by clicking the Edit button. This displays a window where the DECS-150 time and date can be adjusted manually or according to the connected PC clock's date and time.

The screenshot shows the 'Real Time Clock' interface. It features a digital display showing the time as 00:24:13 and the date as 1970-01-01. To the right of the display, the labels 'Time' and 'Date' are visible. Below the display is a blue 'Edit' button.

Figure 11-22. Real-Time Clock Screen

Auto Export Metering

Found under the Tools menu, the auto export metering function is an automated method for saving multiple metering data files at specific intervals over a period of time while connected to a DECS-150. The user specifies the Number of Exports and the Interval between each export. Enter a base filename for the metering data and a folder in which to save. The exports are counted and the count number will be appended to the base filename, making each filename unique. The first export is performed immediately after clicking the Start button. Figure 11-23 illustrates the Auto Export Metering screen.

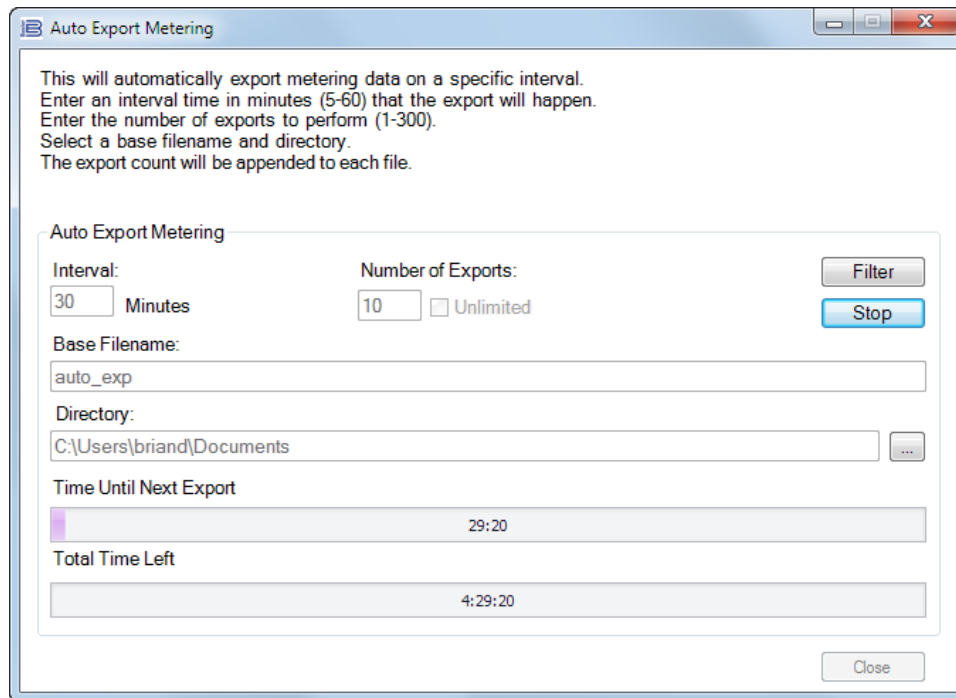


Figure 11-23. Auto Export Metering

12 • Reports

DECS-150 reporting functions include sequence-of-events recording (SER) and data logging (oscillography).

Sequence-of-Events Recording

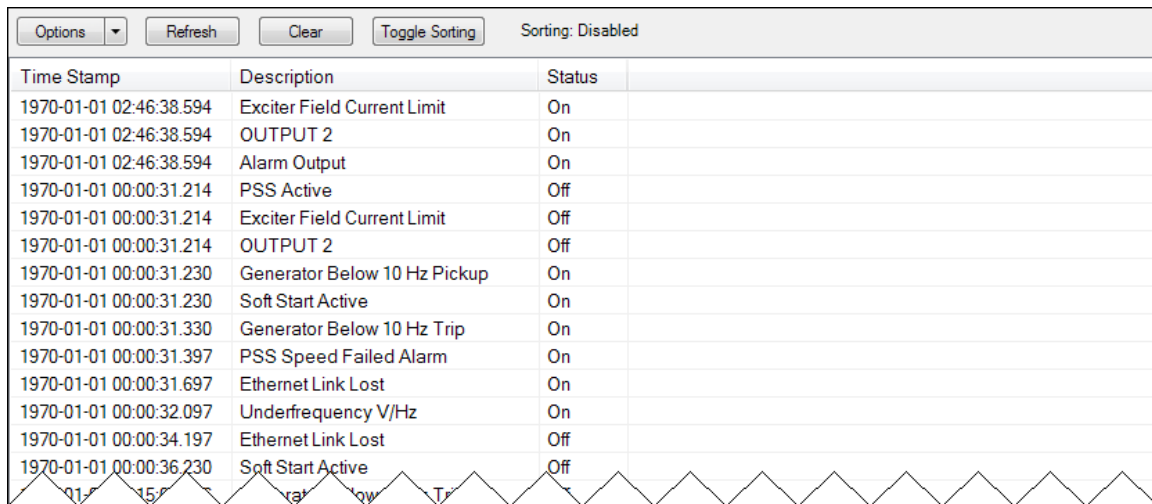
BESTCOMSPlus Navigation Path: Metering Explorer, Reports, Sequence of Events

A sequence-of-events recorder monitors the internal and external status of the DECS-150. Events are scanned at 16 millisecond intervals for 60-hertz units and 20 millisecond intervals for 50-hertz units, with 63 events stored per record. All changes of state that occur during each scan are time- and date-stamped. Sequence-of-events reports are available through BESTCOMSPlus®.

Any one of over 400 monitored data/status points can be recorded in a sequence-of-events record. All points are enabled by default.

If an active connection to a DECS-150 is present, the sequence of events will automatically download. Using the Options button, you can copy, print, or save the sequence of events. The Refresh button is used to refresh/update the list of events. The Clear button will clear all events. The Toggle Sorting button enables sorting. Click on a column header to sort.

The Sequence-of-Events screen is illustrated in Figure 12-1.



Time Stamp	Description	Status
1970-01-01 02:46:38.594	Exciter Field Current Limit	On
1970-01-01 02:46:38.594	OUTPUT 2	On
1970-01-01 02:46:38.594	Alarm Output	On
1970-01-01 00:00:31.214	PSS Active	Off
1970-01-01 00:00:31.214	Exciter Field Current Limit	Off
1970-01-01 00:00:31.214	OUTPUT 2	Off
1970-01-01 00:00:31.230	Generator Below 10 Hz Pickup	On
1970-01-01 00:00:31.230	Soft Start Active	On
1970-01-01 00:00:31.330	Generator Below 10 Hz Trip	On
1970-01-01 00:00:31.397	PSS Speed Failed Alarm	On
1970-01-01 00:00:31.697	Ethernet Link Lost	On
1970-01-01 00:00:32.097	Underfrequency V/Hz	On
1970-01-01 00:00:34.197	Ethernet Link Lost	Off
1970-01-01 00:00:36.230	Soft Start Active	Off

Figure 12-1. Sequence-of-Events Screen

Data Logging

BESTCOMSPlus Navigation Path: Settings Explorer, Report Configuration, Data Log

The data logging function of the DECS-150 can record up to four oscillography records. DECS-150 oscillography records use the IEEE Standard Common Format for Transient Data Exchange (COMTRADE). Each record is time- and date-stamped. After four records have been recorded, the DECS-150 begins recording the next record over the oldest record. Because oscillography records are stored in nonvolatile memory, interruptions in DECS-150 operating power will not affect the integrity of the records.

Setup

When oscillography is enabled, each record can consist of up to six user-selectable parameters with up to 600 data points recorded for each parameter.

A pre-trigger-points setting enables a user-defined number of data points recorded prior to the event trigger to be included in a data log. The value of this setting affects the duration of the recorded pre-trigger points, the recorded post-trigger points, and the duration of the post-trigger points. A sample interval setting establishes the sample rate of the data points recorded. The value of this setting affects the pre- and post-trigger duration values and the total recording duration for a data log.

The Data Log Setup Screen is illustrated in Figure 12-2.

Figure 12-2. Data Log Setup Screen

Triggers

BESTCOMSPlus Navigation Path: Settings Explorer, Report Configuration, DataLog

Data logging may be triggered by mode change, logic change, level changes, or manually through BESTCOMSPlus.

Mode Triggers

Mode triggers initiate data logging as a result of an internal or external DECS-150 status change.

The Mode Triggers screen is illustrated in Figure 12-3.

Figure 12-3. Mode Triggers Screen

Level Triggers

Level triggering initiates a data log based on the value of an internal variable. The variable can be a minimum or maximum value and can be specified to trigger a record when the monitored variable crosses a minimum threshold from above, or a maximum threshold from below. A minimum and maximum threshold may also be selected for the monitored variable, causing the monitored value to trigger a record when it rises above its maximum threshold or decreases below its minimum threshold.

Level triggers are configured in BESTCOMSPlus on the Level Triggers tab (Figure 12-4) in the Data Log area of the Report Configuration. The Level Triggers tab consists of a list of parameters that can be selected to trigger a data log. Each parameter has a level trigger enable setting that configures triggering

of a data log when the parameter increases above the upper threshold setting or decreases below the lower threshold setting. The parameters available to trigger a data log are listed below.

The screenshot shows a 'Level Triggers' configuration screen with four sections. Each section contains two numerical input fields for 'Lower Threshold' and 'Upper Threshold', and a dropdown menu for 'Level Trigger Enable'. All threshold values are currently set to 0.00, and all 'Level Trigger Enable' dropdowns are set to 'No Trigger'.

Section	Lower Threshold	Upper Threshold	Level Trigger Enable
Auxiliary Voltage Input	0.00	0.00	No Trigger
AVR Output	0.00	0.00	No Trigger
AVR PID Error Signal Input	0.00	0.00	No Trigger
Bus Frequency (Hz)	0.00	0.00	No Trigger

Figure 12-4. Level Triggers Screen

- Auxiliary voltage input
- APC desired reference
- APC error
- APC output
- APC state
- AVR output
- AVR PID error signal input
- Bus frequency
- Bus voltage
- Comp. frequency deviation
- Control output
- Cross current input
- Droop
- FCR error
- FCR output
- FCR state
- Field current
- Field voltage
- Frequency response
- Generator/Motor apparent power
- Generator/Motor average current
- Generator/Motor average voltage
- Generator/Motor current Ia
- Generator/Motor current Ib
- Generator/Motor current Ic
- Generator/Motor frequency
- Generator/Motor power factor
- Generator/Motor reactive power
- Generator/Motor real power
- Generator/Motor voltage Vab
- Generator/Motor voltage Vbc
- Generator/Motor voltage Vca
- Negative sequence current
- Negative sequence voltage
- Null balance level
- OEL controller output
- OEL ref.
- OEL state
- Internal State
- Network Load Share
- Position Indication
- Positive sequence current
- Positive sequence voltage
- PSS electrical power
- PSS filtered mech. Power
- PSS final output
- PSS lead/lag #1
- PSS lead/lag #2
- PSS lead/lag #3
- PSS lead/lag #4
- PSS mechanical power
- PSS mechanical power LP #1
- PSS mechanical power LP #2
- PSS mechanical power LP #3
- PSS mechanical power LP #4
- PSS post-limit output
- PSS power HP #1
- PSS pre-limit output
- PSS speed HP #1
- PSS synthesized speed
- PSS terminal voltage
- PSS torsional filter #1
- PSS torsional filter #2
- PSS washed out power
- PSS washed out speed
- SCL controller output
- SCL PF ref.
- SCL ref.
- SCL state
- Terminal frequency deviation
- Time response signal
- UEL controller output

- UEL ref.
- UEL state
- Var/PF error
- Var/PF output
- Var/PF state
- LVRT reference
- LVRT desired reference
- Power in

Logic Triggers

Logic triggering initiates a data log as a result of an internal or external status change. A data log can be triggered by any combination of alarm, contact output, or contact input state changes. The available logic triggers are illustrated in Figure 12-5.

The screenshot shows a web interface titled "Logic Triggers" with three columns of checkboxes:

- Alarm States:** Generator Overvoltage, Generator Undervolt, Loss Of Sensing Voltage, Below 10 Hz, Field Overvoltage, OEL, UEL, SCL, Under Freq Limiter, Set Point Upper Limit, Set Point Lower Limit, EDM, PSS Power Below Threshold, PSS Volt Unbalanced, PSS Current Unbalanced, PSS Speed Failure, PSS Voltage Limit Alarm, GCC Disconnect Timed Out, APC Remote Trip, LFSM Active, LVRT Active, LVRT Remote Trip.
- Relay Outputs:** Watchdog Output, Relay1 Output, Relay2 Output, Breaker Shunt Trip.
- Contact Inputs:** Switch1 Input, Switch2 Input, Switch3 Input, Switch4 Input, Switch5 Input, Switch6 Input, Switch7 Input, Switch8 Input.

Figure 12-5. Logic Triggers Screen

Viewing and Downloading Data Logs through BESTCOMSPlus®

BESTCOMSPlus Navigation Path: Metering Explorer, Reports, Data Log

The Data Log screen (Figure 12-6) shows a list of records along with log number, number of points, date, time, and record type.

Click the Download button to download and save the selected log as a Binary Comtrade, ASCII Comtrade, or ASCII log file. Click the Refresh button to refresh the list of fault reports on the screen. Click the Reset New button to clear the new records. Click the Reset Total button to clear all records.

Click the Trigger Record button to start the recorder. Click the Stop Record button to stop the recorder and save the record to the list.

Click the Print Summary button to open the Print Preview screen and view or print a summary of the selected data log. Click the Print Record button to open the Print Preview screen and view or print the full details of the selected data log.

Download Options

Binary COMTRADE
 ASCII COMTRADE
 ASCII Log

Download Reset New Trigger Record Print Summary
Refresh Reset Total Stop Record Print Record

Report Summary

DECS150 RECORD LOG DIRECTORY
REPORT DATE : 2015-04-29
REPORT TIME : 13:56:45
DEVICE ID : DECS-150
NEW RECORDS : 4 (2015-04-29 13:56:30.266 - 2015-04-29 13:56:42.621)
TOTAL RECORDS : 4 (2015-04-29 13:56:30.266 - 2015-04-29 13:56:42.621)

Record List

Log	Points	Date	Time	Record Type
004	0600	2015-04-29	13:56:42.621	Triggered by User
001	0600	2015-04-29	13:56:30.266	Triggered by User
002	0600	2015-04-29	13:56:34.129	Triggered by User
003	0600	2015-04-29	13:56:38.733	Triggered by User

Figure 12-6. Data Log Screen



13 • Power System Stabilizer

This section only applies to generator applications. The optional (style xPxxx), integrated power system stabilizer (PSS) is an IEEE Std 421.5 type PSS2A/2B/2C, dual-input, “integral of accelerating power” stabilizer that provides supplementary damping for low-frequency, local-mode oscillations and power system oscillations.

PSS features include user-selectable, speed-only sensing, two- or three-wattmeter power measurement, optional frequency-based operation, and generator and motor control modes.

Note

Three-phase current sensing and three-phase voltage sensing is required for PSS operation.

A summary of the operational settings appears at the end of this section.

BESTCOMSP_{Plus} Navigation Path: [Settings Explorer, PSS](#)

Supervisory Function and Setting Groups

A supervisory function enables PSS operation only when a sufficient load is applied to the generator. Two separate groups of PSS settings enable stabilizer operation tailored for two distinct load conditions.

Supervisory Function

When PSS control is enabled, the Power-On Threshold setting determines the level of power (watts) where PSS operation is automatically enabled. This threshold is a per-unit setting based on the generator ratings. The *Configuration* section provides information about entering the generator and system ratings. A Hysteresis setting provides a margin below the power-on threshold so that transient dips in power (watts) will not disable stabilizer operation. This hysteresis is a per-unit setting based on the generator ratings.

Setting Groups

When setting group selection is enabled, the Threshold setting establishes the power level where the PSS gain settings are switched from the primary group to the secondary group. After a transfer to the secondary gain settings, the Hysteresis setting determines the level of (decreasing) power where a transfer back to the primary gain settings will occur.

Theory of Operation

The PSS uses an indirect method of power system stabilization that employs two signals: shaft speed and electrical power. This method eliminates the undesirable components from the speed signal (such as noise, lateral shaft run-out, or torsional oscillations) while avoiding a reliance on the difficult-to-measure mechanical power signal.

PSS function is illustrated by the function blocks and software switches shown in Figure 13-1. This illustration is also available in BESTCOMSP_{Plus} by clicking the PSS Model Info button located on the Control tab.

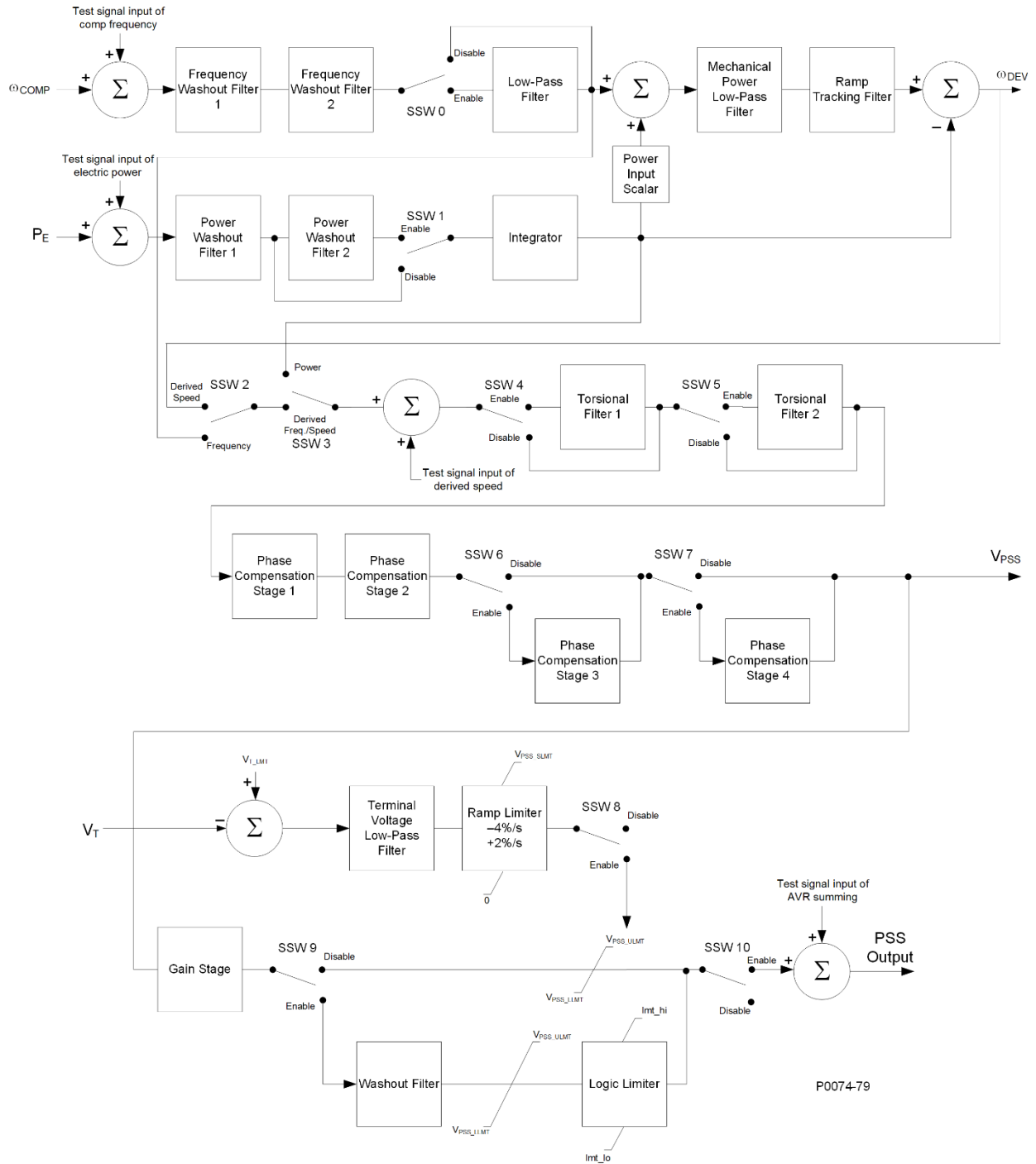


Figure 13-1. PSS Function Blocks and Software Switches

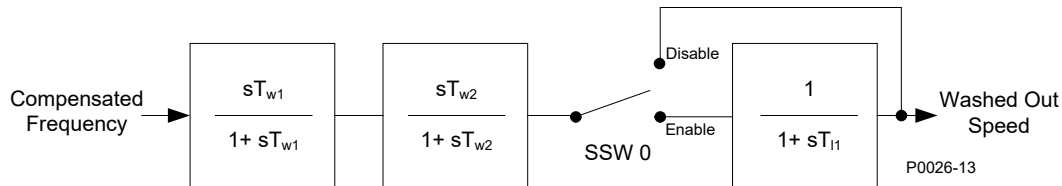
Speed Signal

The speed signal is converted to a constant level that is proportional to the shaft speed (frequency).

Two high-pass (frequency washout) filter stages are applied to the resulting signal to remove the average speed level and produce a speed deviation signal. This ensures that the stabilizer reacts only to changes in speed and does not permanently alter the generator terminal voltage reference.

The frequency washout filter stages are controlled by time constant settings T_{w1} and T_{w2} . Low-pass filtering of the speed deviation signal can be enabled or disabled through software switch SSW 0. The low-pass filter time constant is adjusted by the T_{I1} setting.

Figure 13-2 shows the high-pass and low-pass filter transfer function blocks in frequency domain form. The letter “s” is used to represent the complex frequency of Laplace operator.



PSS Frequency Input Signal

Figure 13-2. Speed Signal

Rotor Frequency Calculation

During steady-state conditions, the terminal frequency of the generator is a good measure of rotor speed. However, this may not be the case during low frequency transients, due to the voltage drop across the machine reactance. To compensate for this effect, the DECS-150 first calculates the terminal voltages and currents. It then adds the voltage drop across the quadrature reactance to the terminal voltages to obtain internal machine voltages. These voltages are then used to calculate the rotor frequency. This gives a more accurate measure of rotor speed during low frequency transients when stabilizing action is required.

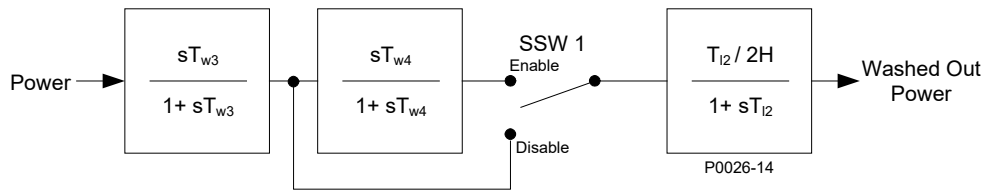
The quadrature axis compensation used in the rotor frequency calculation is entered through the Quadrature X_q setting.

Generator Electrical Power Signal

Figure 13-3 illustrates the operations performed on the power input signal to produce the integral of electrical power deviation signal.

The generator electrical power output is derived from the generator VT secondary voltages and generator CT secondary currents applied to the DECS-150. Three-phase current sensing is required for PSS operation.

The power output is high-pass (washout) filtered to produce the required power deviation signal. If additional washout filtering is desired, a second high-pass filter can be enabled by software switch SSW 1. The first high-pass filter is controlled by time constant setting T_{w3} and the second high-pass filter is controlled by time constant setting T_{w4} .



PSS Power Input Signal

Figure 13-3. Generator Electrical Power Signal

After high-pass filtering, the electrical power signal is integrated and scaled, combining the generator inertia constant (2H) with the speed signal. Low-pass filtering within the integrator is controlled by time constant T12.

Derived Mechanical Power Signal

The speed deviation signal and integral of electrical power deviation signal are combined to produce a derived, integral of mechanical power signal.

An adjustable gain stage, Kpe, establishes the amplitude of the electrical power input used by the PSS function.

The derived integral of mechanical power signal is then passed through a mechanical-power, low-pass filter and ramp tracking filter. The low-pass filter is controlled by time constant T13 and provides attenuation of torsional components appearing in the speed input path. The ramp tracking filter produces a zero, steady-state error to ramp changes in the integral of electric power input signal. This limits the stabilizer output variation to very low levels for the mechanical power rates of change that are normally encountered during operation of utility-scale generators. The ramp tracking filter is controlled by time constant Tr. An exponent consisting of a numerator and denominator is applied to the mechanical power filter.

Processing of the derived integral of mechanical power signal is illustrated in Figure 13-4.

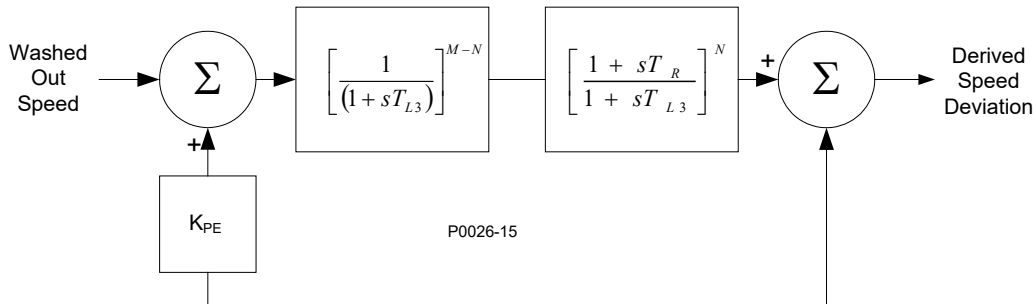


Figure 13-4. Derived Mechanical Power Signal

Stabilizing Signal Selection

Figure 13-5 illustrates how software switches SSW 2 and SSW 3 are used to select the stabilizing signal. Derived speed deviation is selected as the stabilizing signal when the SSW 2 setting is Derived Speed and the SSW 3 setting is Derived Frequency/Speed. Washed out speed is selected as the stabilizing signal when the SSW 2 setting is Frequency and the SSW 3 setting is Derived Frequency/Speed. Washed out power is selected as the stabilizing signal when the SSW 3 setting is Power. When the SSW 3 setting is Power, the SSW 2 setting has no effect.

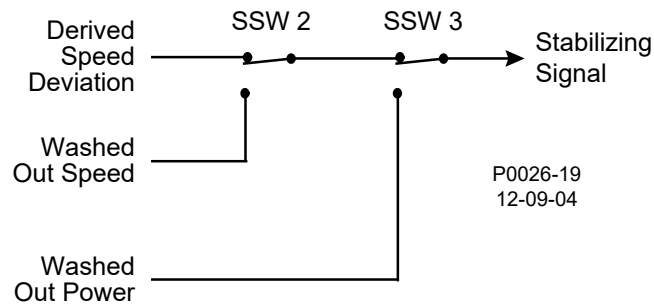


Figure 13-5. Stabilizing Signal Selection

Torsional Filters

Two torsional filters, shown in Figure 13-6, are available after the stabilizing signal and before the phase compensation blocks. The torsional filters provide the desired gain reduction at a specified frequency. The filters compensate the torsional frequency components present in the input signal.

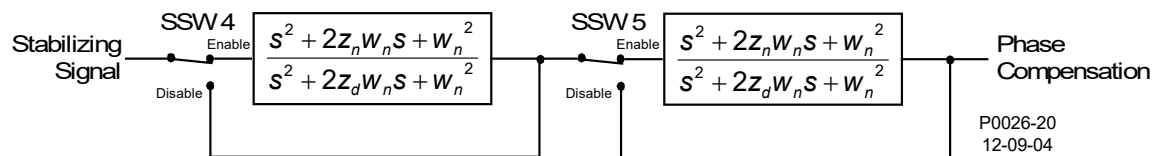


Figure 13-6. Torsional Filters

Software switch SSW 4 enables and disables torsional filter 1 and SSW 5 enables and disables torsional filter 2.

Torsional filters 1 and 2 are controlled by a zeta numerator (Zeta Num), zeta denominator (Zeta Den), and a frequency response parameter (W_n).

Phase Compensation

The derived speed signal is modified before it is applied to the voltage regulator input. Filtering of the signal provides phase lead at the electromechanical frequencies of interest (0.1 to 5 Hz). The phase lead requirement is site-specific and is required to compensate for phase lag introduced by the closed-loop voltage regulator.

Four phase compensation stages are available. Each phase compensation stage has a phase lead time constant (T_1, T_3, T_5, T_7) and a phase lag time constant (T_2, T_4, T_6, T_8). Normally, the first two lead-lag stages are adequate to match the phase compensation requirements of a unit. If needed, the third and fourth stages may be added through the settings of software switches SSW 6 and SSW 7. Figure 13-7 illustrates the phase compensation stages and associates software switches.

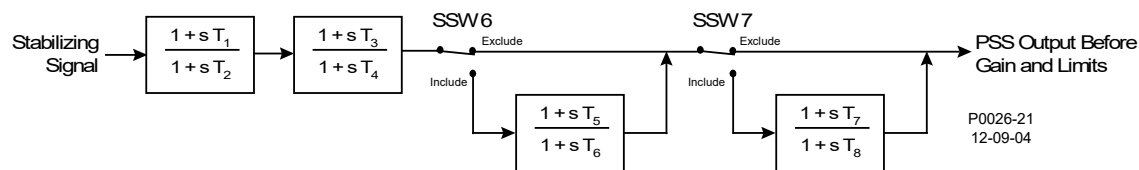


Figure 13-7. Phase Compensation

Washout Filter and Logic Limiter

The output of the phase compensation stages is connected, through a stabilizer gain stage, to the washout filter and logic limiter.

Software switch SSW 9 enables and bypasses the washout filter and logic limiter. The washout filter has two time constants: Normal and Limit (less than normal).

The logic limiter compares the signal from the washout filter with the Logic Limiter Upper and Lower Limit Settings. If the counter reaches the set delay time, the time constant for the washout filter changes from the normal time constant to the limit time constant. When the signal returns to within the specified limits, the counter resets and the washout filter time constant changes back to the normal time constant.

Figure 13-8 illustrates the washout filter and logic limiter.

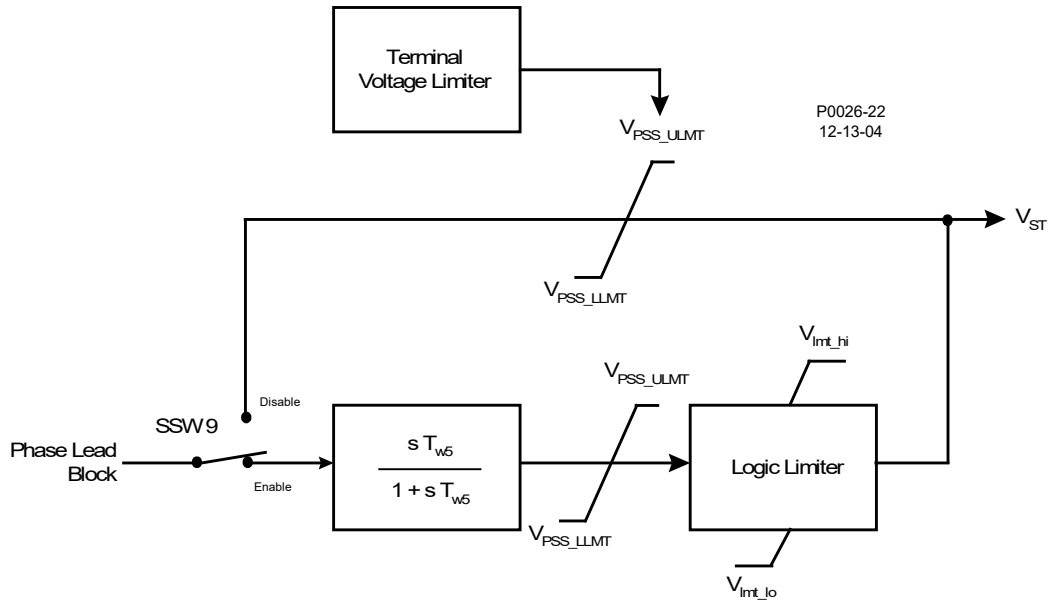


Figure 13-8. Washout Filter and Logic Limiter

Output Stage

Prior to connecting the stabilizer output signal to the voltage regulator input, adjustable gain and upper and lower limits are applied. The stabilizer output is connected to the voltage regulator input when the software switch SSW 10 setting is On. Processing of the stabilizer output signal is illustrated in Figure 13-9.

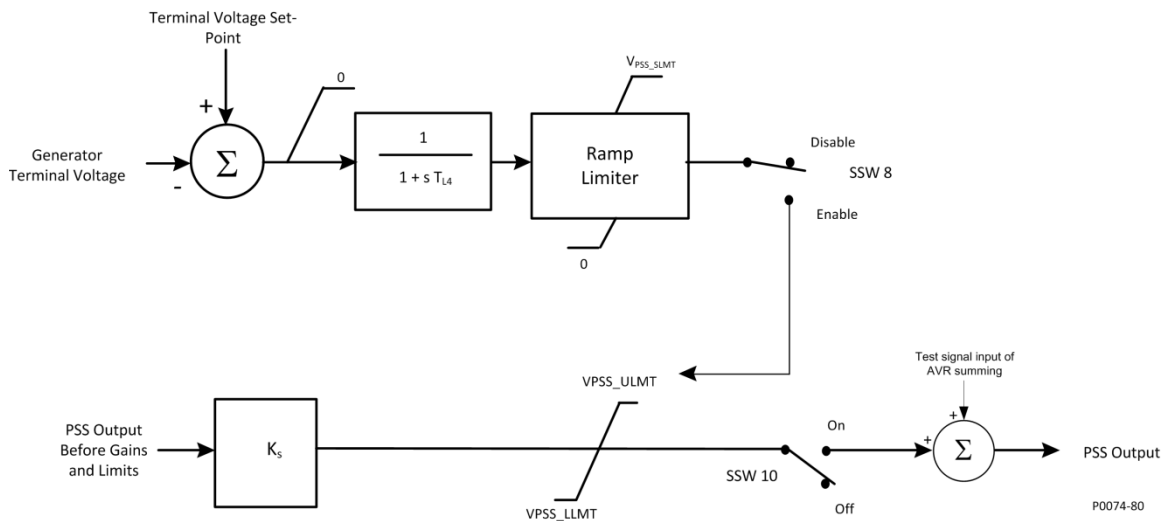


Figure 13-9. Output Stage

Terminal Voltage Limiter

Since the PSS operates by modulating the excitation, it may counteract the voltage regulator’s attempts to maintain terminal voltage within a tolerance band. To avoid creating an overvoltage condition, the PSS has a terminal voltage limiter (shown in Figure 13-8) that reduces the upper output limit to zero when the

generator voltage exceeds the terminal voltage setpoint. The terminal voltage limiter is enabled and disabled by software switch SSW 8. The limit setpoint is normally selected such that the limiter will eliminate any contribution from the PSS before the timed overvoltage or volts per hertz protection operates.

The limiter reduces the stabilizer's upper limit, V_{PSS_ULMT} , at a fixed rate until zero is reached or overvoltage is no longer present. The limiter does not reduce the AVR reference below its normal level; it will not interfere with system voltage control during disturbance conditions. The error signal (terminal voltage minus the limit start point) is processed through a conventional low-pass filter to reduce the effect of measurement noise. The low-pass filter is controlled by a time constant.

Operational Settings

PSS settings are configured exclusively through the BESTCOMSP^{Plus}® interface. These settings are illustrated in Figure 13-10 through Figure 13-13.

Configure

Setting Group Logic

Enable

Power Level

Threshold
0.00

Hysteresis
0.00

Figure 13-10. PSS Configure Screen

Control

PSS Control

Enable [PSS Model Info...](#)

Primary

Supervisory Function

Power-On Threshold
0.00

Power Hysteresis
0.00

Software Switch (SSW) Settings

SSW 0 - Speed Low Pass Filter Disabled	SSW 6 - 3rd Lead/Lag Stage Exclude
SSW 1 - Power Washout Filter #2 Disabled	SSW 7 - 4th Lead/Lag Stage Exclude
SSW 2 - PSS Signal Der. Speed	SSW 8 - Term. Voltage Limiter Disabled
SSW 3 - PSS Signal Der. Freq./Speed	SSW 9 - Logic Limiter Disabled
SSW 4 - Torsional Filter 1 Disabled	SSW 10 - PSS Output Off
SSW 5 - Torsional Filter 2 Disabled	

Secondary

Supervisory Function

Power-On Threshold
0.00

Power Hysteresis
0.00

Software Switch (SSW) Settings

SSW 0 - Speed Low Pass Filter Disabled	SSW 6 - 3rd Lead/Lag Stage Exclude
SSW 1 - Power Washout Filter #2 Disabled	SSW 7 - 4th Lead/Lag Stage Exclude
SSW 2 - PSS Signal Der. Speed	SSW 8 - Term. Voltage Limiter Disabled
SSW 3 - PSS Signal Der. Freq./Speed	SSW 9 - Logic Limiter Disabled
SSW 4 - Torsional Filter 1 Disabled	SSW 10 - PSS Output Off
SSW 5 - Torsional Filter 2 Disabled	

Figure 13-11. PSS Control Screen

Parameter	
<div style="display: flex; justify-content: space-between;"> <div style="width: 48%;"> <p>Primary</p> <p>Low-Pass/Ramp Tracking</p> <p>T11 - Time Const. (s) <input type="text" value="0.00"/> Tr - Time Const. (s) <input type="text" value="0.50"/></p> <p>T12 - Time Const. (s) <input type="text" value="1.00"/> N - Num Exp. <input type="text" value="1"/></p> <p>T13 - Time Const. (s) <input type="text" value="0.10"/> M - Den Exp. <input type="text" value="5"/></p> <p>High-Pass Filtering/Integration</p> <p>Tw1 - Time Const. (s) <input type="text" value="1.00"/> Tw4 - Time Const. (s) <input type="text" value="1.00"/></p> <p>Tw2 - Time Const. (s) <input type="text" value="1.00"/> H - Inertia <input type="text" value="1.00"/></p> <p>Tw3 - Time Const. (s) <input type="text" value="1.00"/></p> <p>Torsional Filters</p> <p>Zeta Num 1 <input type="text" value="0.50"/> Zeta Num 2 <input type="text" value="0.50"/></p> <p>Zeta Den 1 <input type="text" value="0.25"/> Zeta Den 2 <input type="text" value="0.25"/></p> <p>Wn 1 <input type="text" value="42.05"/> Wn 2 <input type="text" value="42.05"/></p> <p>Rotor Freq Calculation</p> <p>Quadrature Xq <input type="text" value="0.000"/></p> <p>Power Input</p> <p>Kpe <input type="text" value="1.00"/></p> <p>Phase Comp - Time Constants</p> <p>T1 - 1st Phase Lead (s) <input type="text" value="1.000"/> T5 - 3rd Phase Lead (s) <input type="text" value="1.000"/></p> <p>T2 - 1st Phase Lag (s) <input type="text" value="1.000"/> T6 - 3rd Phase Lag (s) <input type="text" value="1.000"/></p> <p>T3 - 2nd Phase Lead (s) <input type="text" value="1.000"/> T7 - 4th Phase Lead (s) <input type="text" value="1.000"/></p> <p>T4 - 2nd Phase Lag (s) <input type="text" value="1.000"/> T8 - 4th Phase Lag (s) <input type="text" value="1.000"/></p> </div> <div style="width: 48%;"> <p>Secondary</p> <p>Low-Pass/Ramp Tracking</p> <p>T11 - Time Const. (s) <input type="text" value="0.00"/> Tr - Time Const. (s) <input type="text" value="0.50"/></p> <p>T12 - Time Const. (s) <input type="text" value="1.00"/> N - Num Exp. <input type="text" value="1"/></p> <p>T13 - Time Const. (s) <input type="text" value="0.10"/> M - Den Exp. <input type="text" value="5"/></p> <p>High-Pass Filtering/Integration</p> <p>Tw1 - Time Const. (s) <input type="text" value="1.00"/> Tw4 - Time Const. (s) <input type="text" value="1.00"/></p> <p>Tw2 - Time Const. (s) <input type="text" value="1.00"/> H - Inertia <input type="text" value="1.00"/></p> <p>Tw3 - Time Const. (s) <input type="text" value="1.00"/></p> <p>Torsional Filters</p> <p>Zeta Num 1 <input type="text" value="0.50"/> Zeta Num 2 <input type="text" value="0.50"/></p> <p>Zeta Den 1 <input type="text" value="0.25"/> Zeta Den 2 <input type="text" value="0.25"/></p> <p>Wn 1 <input type="text" value="42.05"/> Wn 2 <input type="text" value="42.05"/></p> <p>Rotor Freq Calculation</p> <p>Quadrature Xq <input type="text" value="0.000"/></p> <p>Power Input</p> <p>Kpe <input type="text" value="1.00"/></p> <p>Phase Comp - Time Constants</p> <p>T1 - 1st Phase Lead (s) <input type="text" value="1.000"/> T5 - 3rd Phase Lead (s) <input type="text" value="1.000"/></p> <p>T2 - 1st Phase Lag (s) <input type="text" value="1.000"/> T6 - 3rd Phase Lag (s) <input type="text" value="1.000"/></p> <p>T3 - 2nd Phase Lead (s) <input type="text" value="1.000"/> T7 - 4th Phase Lead (s) <input type="text" value="1.000"/></p> <p>T4 - 2nd Phase Lag (s) <input type="text" value="1.000"/> T8 - 4th Phase Lag (s) <input type="text" value="1.000"/></p> </div> </div>	

Figure 13-12. PSS Parameter Screen

Output Limiter

Primary	Secondary
PSS Output Limiting Upper Limit 0.000 Lower Limit 0.000	PSS Output Limiting Upper Limit 0.000 Lower Limit 0.000
Stabilizer Gain Ks 0.00	Stabilizer Gain Ks 0.00
Terminal Voltage Limiter Time Constant (s) 1.000 Setpoint 1.000	Terminal Voltage Limiter Time Constant (s) 1.000 Setpoint 1.000
Logic Limiter Washout Filter Normal Time 10.00 Limit Time 0.30	Logic Limiter Washout Filter Normal Time 10.00 Limit Time 0.30
Logic Output Limiter Upper Limit 0.020 Lower Limit -0.020 Time Delay 0.50	Logic Output Limiter Upper Limit 0.020 Lower Limit -0.020 Time Delay 0.50

Figure 13-13. PSS Output Limiter Screen



14 • Stability Tuning

Machine stability tuning in the DECS-150 is achieved through the calculation of PID parameters. PID stands for Proportional, Integral, Derivative. The word proportional indicates that the response of the DECS-150 output is proportional or relative to the difference of change observed. Integral means that the DECS-150 output is proportional to the amount of time that a difference is observed. Integral action eliminates offset. Derivative means that the DECS-150 output is proportional to the required rate of excitation change. Derivative action avoids excitation overshoot.

Caution

All stability tuning must be performed with no load on the system or equipment damage may occur.

AVR Mode

BESTCOMSPlus Navigation Path: Settings Explorer, Operating Settings, Gain, AVR

Two sets of PID settings are provided to optimize performance under two distinct operating conditions, such as with the power system stabilizer (PSS) in or out of service (generator applications only). A fast controller provides optimum transient performance with the PSS in service while a slower controller can provide improved damping of first swing oscillations when the PSS is offline.

BESTCOMSPlus® primary and secondary AVR stability settings are shown in Figure 14-1.

Predefined Stability Settings

Twenty predefined sets of stability settings are available with the DECS-150. Appropriate PID values are implemented based on the nominal machine frequency selected (see the *Configuration* section) and the combination of machine ($T'do$) and exciter ($Texc$) time constants selected from the gain option list. (The default value for the exciter time constant is the machine time constant divided by six.)

Additional settings are available to remove the effects of noise on numerical differentiation (AVR derivative time constant T_d) and set the voltage regulator gain level of the PID algorithm (K_a).

Custom Stability Settings

Stability tuning can be tailored for optimum machine transient performance. Selecting a primary gain option of “custom” enables entry of custom proportional (K_p), integral (K_i), and derivative (K_d) gains.

When tuning the stability gain settings, consider the following guidelines:

- If the transient response has too much overshoot, decrease K_p . If the transient response is too slow, with little or no overshoot, increase K_p .
- If the time to reach steady-state is too long, increase K_i .
- If the transient response has too much ringing, increase K_d .

The screenshot displays the AVR control interface, divided into Primary and Secondary sections. Each section contains input fields for PID parameters: Kp (Proportional Gain), Ki (Integral Gain), Kd (Derivative Gain), Td (Derivative Time Constant), and Ka (Voltage Regulator Gain). The Ka field includes a sub-field for the Recommended Ka value. Below the parameter fields, there are 'PID Pre-Settings' sections with dropdown menus for 'Primary Gain Option' and 'Secondary Gain Option', and buttons for 'Primary PID Calculator' and 'Secondary PID Calculator'. At the bottom left, there is an 'Auto Tuning' section with an 'Auto Tune' button.

Figure 14-1. AVR Screen

PID Calculator

The PID calculator is accessed by clicking the PID calculator button (see Figure 14-1) and is available only when the primary gain option is “Custom”. The PID calculator (Figure 14-2) calculates the gain parameters K_p , K_i , and K_d based on the machine time constants (T_{do}) and exciter time constant (T_e). If the exciter time constant is not known, it can be forced to the default value, which is the machine time constant divided by six. A derivative time constant (T_d) setting field enables the removal of noise effects on numerical differentiation. A voltage regulator gain (K_a) setting field sets the voltage regulator gain level of the PID algorithm. Calculated and entered parameters can be applied upon closure of the PID calculator.

Machine information appears in the PID Record List where records can be added or removed.

A group of settings can be saved with a unique name and added to a list of gain setting records available for application. Upon completion of stability tuning, undesired records can be removed from the record list.

Caution

Calculated or user-defined PID values are to be implemented only after their suitability for the application has been verified by the user. Incorrect PID numbers can result in poor system performance or equipment damage.

Primary PID Calculator

Excitation Control Data

Generator Information

Tdo - Gen. Time Constant
2.00

Use Default Exciter Time Constant

Te - Exciter Time Constant
0.33

Gain Parameters

84.827 Kp - Proportional Gain

141.313 Ki - Integral Gain

13.510 Kd - Derivative Gain

0.00 Td - Derivative Time Constant

0.100 Ka - Voltage Regulator Gain

PID Record List

Generator Information	Kp	Ki	Kd	Td	Ka	Tdo	Te
:	84.827	141.313	13.510	0.00	0.100	2.00	0.33

Add Record Remove Record Apply Gain Parameters Close

Figure 14-2. Primary PID Calculator Screen

Auto Tuning

Auto tuning only applies to generator applications. During commissioning, excitation system parameters may not be known. These unknown variables traditionally cause the commissioning process to consume large amounts of time and fuel. With the development of auto tuning, the excitation system parameters are now automatically identified and the PID gains are calculated using well-developed algorithms. Automatically tuning the PID controller greatly reduces commissioning time and cost.

The auto tuning function is accessed by clicking the Auto Tune button (Figure 14-1). BESTCOMSPlus® must be in Live Mode in order to begin the auto tuning process. The auto tuning window (Figure 14-3) provides options for choosing the PID Design Mode and the Power Input Mode. When the desired settings are selected, the Start Auto Tune button is clicked to start the process. After the process is complete, click the Save PID Gains (Primary) button to save the data. The File menu contains options for importing, exporting, and printing graph (*.gph) files.

Caution

PID values calculated by the Auto Tuning function are to be implemented only after their suitability for the application has been verified by the user. Incorrect PID numbers can result in poor system performance or equipment damage.

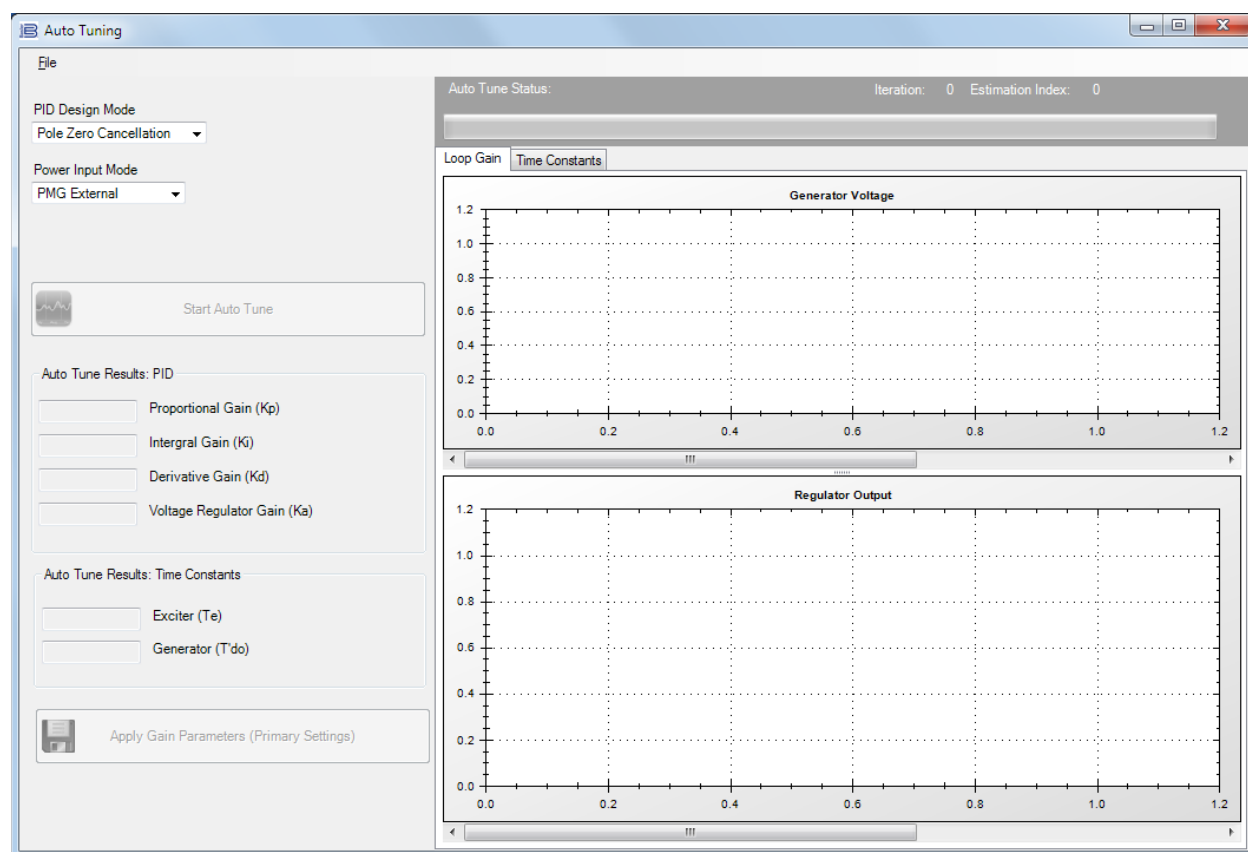


Figure 14-3. Auto Tuning Screen

FCR Mode

BESTCOMSPi_{us} Navigation Path: Settings Explorer, Operating Settings, Gain, FCR

Stability tuning can be tailored for optimum performance when operating in field current regulation mode. BESTCOMSPi_{us} FCR stability settings are illustrated in Figure 14-4.

FCR Mode Stability Settings

The DECS-150 bases its field current output upon the following settings.

The proportional gain (K_p) is multiplied by the error between the field current setpoint and the actual field current value. Decreasing K_p reduces overshoot in the transient response. Increasing K_p speeds the transient response.

The integral gain (K_i) is multiplied by the integral of the error between the current setpoint and the actual field current value. Increasing K_i reduces the time to reach a steady state.

The derivative gain (K_d) is multiplied by the derivative of the error between the current setpoint and the actual field current value. Increasing K_d reduces ringing in the transient response.

Additional FCR stability settings remove the noise effect on numerical differentiation (derivative time constant T_d) and set the voltage regulator gain level of the PID algorithm (K_a) with recommended gain calculation.

FCR	
FCR	
Kp - Proportional Gain	(Recommended Ka)
10.000	0.099
Ki - Integral Gain	
50.000	
Kd - Derivative Gain	
0.000	
Td - Derivative Time Constant	
0.00	
Ka - Voltage Regulator Gain	
0.100	

Figure 14-4. FCR Screen

Other Modes and Functions

BESTCOMSPPlus Navigation Path: Settings Explorer, Operating Settings, Gain, var, PF, OEL, UEL, SCL

Settings for stability tuning of the Var and Power Factor modes are provided in the DECS-150 along with settings for stability tuning of limiters, the voltage matching function, and main field voltage response.

Figure 14-5 illustrates these settings as they appear in BESTCOMSPPlus.

Var Mode

The integral gain (K_i) adjusts the Var mode integral gain which determines the characteristic of the DECS-150 dynamic response to a changed var setpoint.

The loop gain (K_g) adjusts the coarse loop-gain level of the PI algorithm for var control.

Power Factor Mode

The integral gain (K_i) adjusts the Power Factor mode integral gain which determines the characteristic of the DECS-150 dynamic response to a changed power factor setpoint.

The loop gain (K_g) adjusts the coarse loop-gain level of the PI algorithm for power factor control.

Overexcitation Limiter (OEL)

The integral gain (K_i) adjusts the rate at which the DECS-150 responds during an overexcitation condition.

The integral loop gain (K_g) adjusts the coarse loop-gain level of the PI algorithm for the overexcitation limiter function.

Underexcitation Limiter (UEL)

The integral gain (K_i) adjusts the rate at which the DECS-150 responds during an underexcitation condition.

The loop gain (K_g) adjusts the coarse loop-gain level of the PI algorithm for the underexcitation limiter function.

Stator Current Limiter (SCL)

The integral gain (K_i) adjusts the rate at which the DECS-150 limits stator current.

The loop gain (K_g) adjusts the coarse loop-gain level of the PI algorithm for the stator current limiter function.

Voltage Matching

The integral gain (K_i) adjusts the rate at which the DECS-150 matches the machine voltage to the bus voltage.

The screenshot displays a control interface with the title "var, PF, OEL, UEL, SCL". It contains several parameter blocks, each with two input fields for "Ki - Integral Gain" and "Kg - Loop Gain".

Parameter	Ki - Integral Gain	Kg - Loop Gain
var	0.100	1.000
OEL	10.000	0.100
SCL	1.000	0.200
PF	0.100	1.000
UEL	0.100	0.500
Voltage Matching	-	0.050

Figure 14-5. Var, PF, OEL, UEL, SCL Screen

15 • Mounting

The DECS-150 is normally located in the machine conduit box. It is designed for behind-the-panel mounting and requires a cutout for front panel viewing and access to the front-panel USB jack (if so equipped). Supplied mounting hardware consists of six #12 thread-forming screws. The screws pass through mounting holes in the conduit box and thread into the plastic shell of the DECS-150. The screws are equipped with O-ring seals. The recommended torque for the steel mounting screws is 3.95 newton-meters (35 inch-pounds). The unit must be mounted where the ambient temperature does not exceed the allowable environmental conditions called out in the *Specifications* section. DECS-150 package dimensions are shown in Figure 15-1. Cutout and drilling dimensions are shown in Figure 15-2. Drawing dimensions are shown in inches and millimeters (in parenthesis).

Projection mounting is possible with an optional mounting bracket. Request part number 9576500050.

Installation for EMC Compliance

The DECS-150 must be mounted inside a grounded, metal, EMC-type enclosure (conduit box).

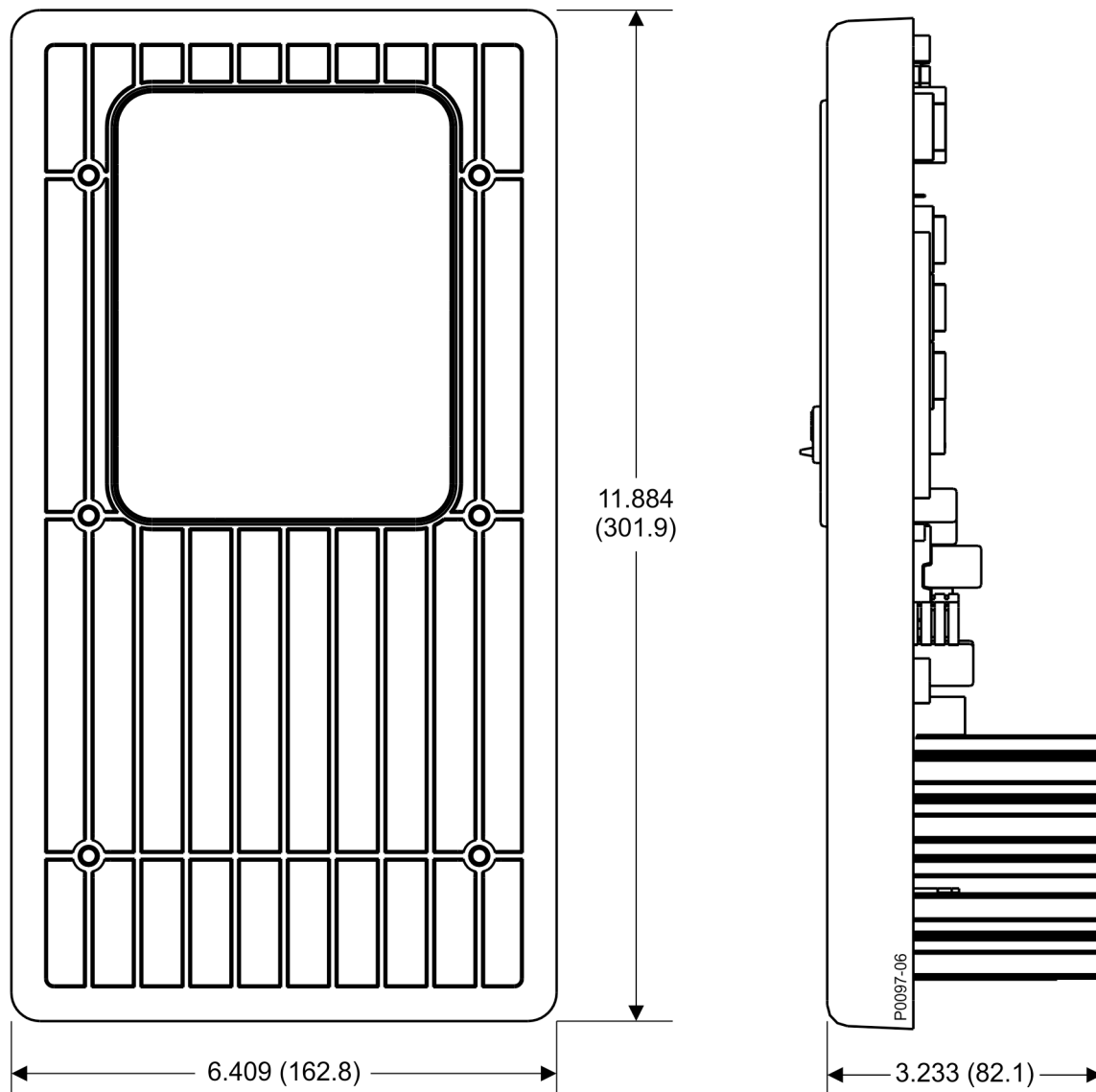


Figure 15-1. DECS-150 Dimensions

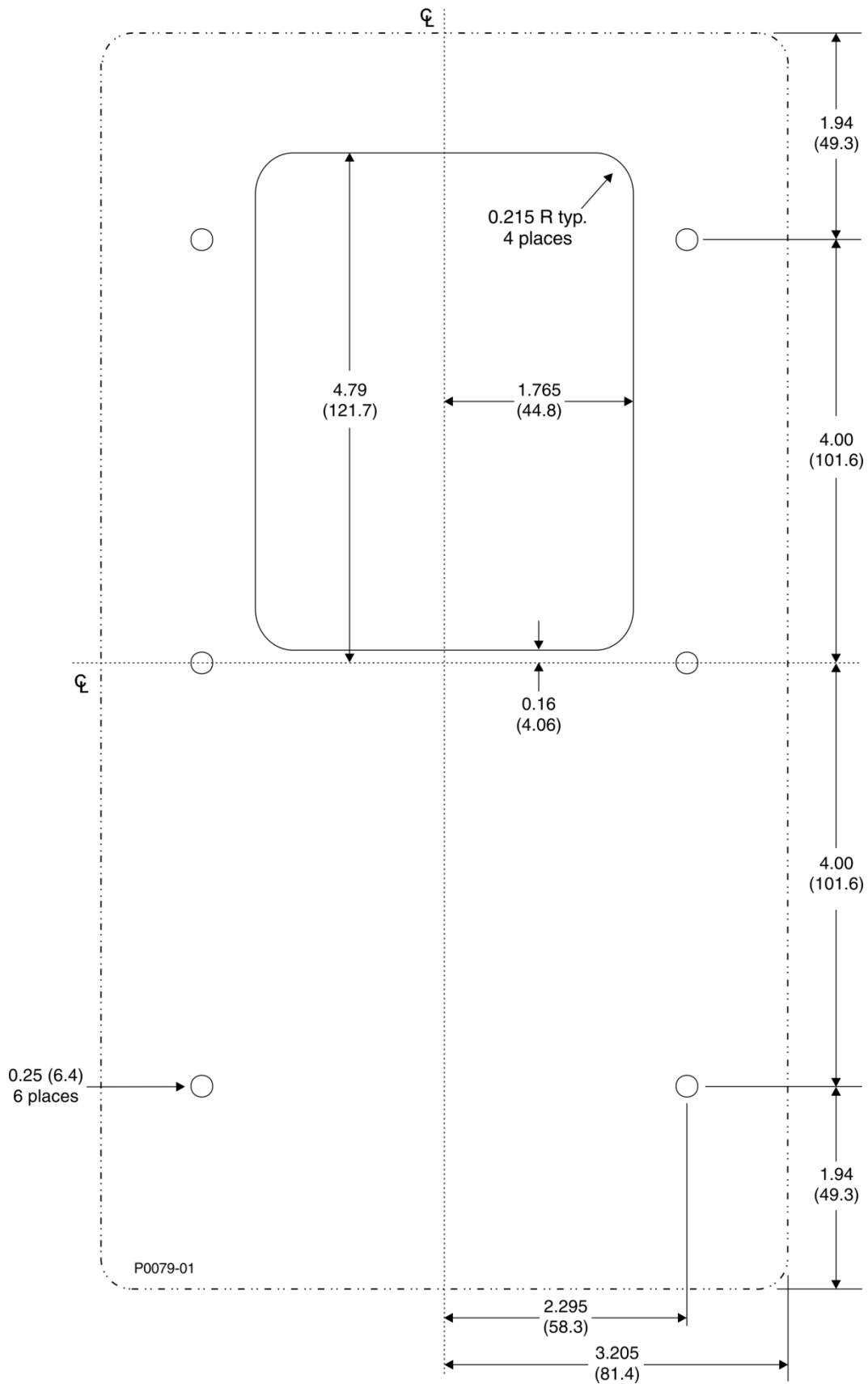


Figure 15-2. Cutout and Drilling Dimensions

16 • Terminals and Connectors

DECS-150 terminals and connectors are located on the rear panel as illustrated in Figure 16-1. DECS-150 terminals consist of single-row, multiple-pin headers that mate with removable connectors wired by the user. The USB port is located on the front or rear panel as specified by the DECS-150 style number. The USB port and Ethernet port are described in the *Communications* section.

DECS-150 connections are made with connectors with spring compression terminals. These connectors plug into headers on the DECS-150. The connectors and headers have a dovetailed edge that ensures proper connector orientation. The 15-position connectors and headers are uniquely keyed to ensure that a connector mates only with the correct header. Connector terminals accept a maximum wire size of 12 AWG. Connectors and headers may contain tin- or gold-plated conductors.

Caution

By mating conductors of dissimilar metals, galvanic corrosion could occur which may lead to signal loss.

Terminal Descriptions

DECS-150 terminals are described in the following paragraphs.

Power Supply Inputs (3, 4, 5, GND)

These terminals accept single-phase or three-phase operating power for the excitation power stage of the DECS-150. A ground for the operating power connections is provided at terminal GND.

For more information, refer to the *Power Input and Output* section.

Generator/Motor Voltage Sensing Inputs (E1, E2, E3)

Three-phase generator/motor sensing voltage, obtained from user-supplied voltage transformers (VTs) if required, connect to these terminals.

For more information, refer to the *Voltage and Current* section.

Bus Voltage Sensing Inputs (B1, B2, B3)

Three-phase bus sensing voltage, obtained from user-supplied potential transformers (PTs) if required, connects to these terminals.

For more information, refer to the *Voltage and Current* section.

Generator/Motor Current Sensing Inputs (IA+, IA-, IB+, IB-, IC+, IC-)

These terminals connect to user-supplied current transformers (CTs) providing three phases of generator/motor sensing current.

For more information, refer to the *Voltage and Current* section.

Cross-Current Compensation Input (CC+, CC-)

These terminals connect to user-supplied current transformers (CTs) providing a cross-current compensation signal.

For more information, refer to the *Voltage and Current* section.

Power (Field) Output (F+, F-)

Excitation power is supplied to the field through these terminals.

For more information, refer to the *Power Input and Output* section.

Accessory Input (I+, I-, V+, V-)

These terminals accept an external analog control signal for auxiliary control of the regulation setpoint.

For more information, refer to the *Auxiliary Control* section.

Contact Inputs (IN1, IN2, IN3, IN4, IN5, IN6, IN7, IN8, COM)

Programmable contact inputs 1 through 8 are applied to these inputs.

For more information, refer to the *Contact Inputs and Outputs* section.

Watchdog Output (WD1, WD2, WD3)

Watchdog output connections are made at these terminals.

For more information, refer to the *Contact Inputs and Outputs* section.

Programmable Outputs (OC1, OC2)

Programmable output connections are made at these terminals.

For more information, refer to the *Contact Inputs and Outputs* section.

Breaker Shunt Trip Output (ST+, ST-)

This output provides an electronic switch capable of 100 mAdc that can be used to control an external circuit breaker.

External Tracking Inputs (GND, C2L, C2H)

A second DECS-150 connects to these terminals for the purpose of setpoint tracking.

For more information, refer to the *Regulation* section.

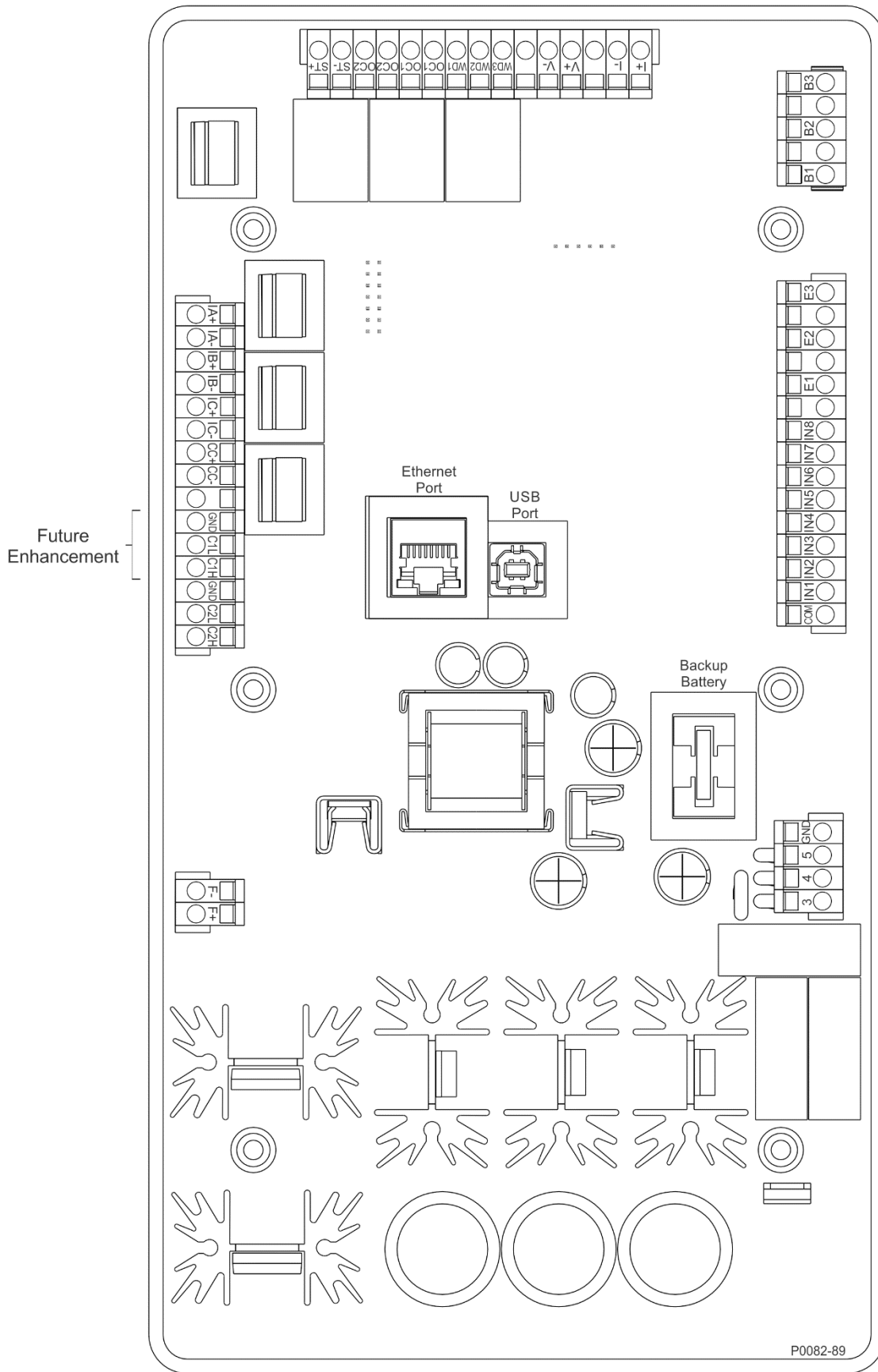


Figure 16-1. DECS-150 Terminals



17 • Typical Connections

Typical connection diagrams are provided in this section as a guide when wiring the DECS-150 for communication, contact inputs, contact outputs, sensing, and operating power.

Typical connections for shunt powered generator applications are shown in Figure 17-1. Typical connections for PMG powered generator applications are shown in Figure 17-2. Typical connections for station powered generator applications are shown in Figure 17-3. Typical connections for station powered motor applications are shown in Figure 17-4. Three-phase-delta voltage sensing connections are shown. The drawing notes in Figure 17-1 through Figure 17-4 correspond to the descriptions found in Table 17-1.

Table 17-1. Typical Connection Drawing Descriptions

Drawing Note	Description
1	Optional - ICRM-7 (Inrush Current Reduction Module), Basler part number 9387900103.
2	Operating (bridge) power input. For single-phase power, omit one phase connection. See the <i>Power Input</i> section for operating power ratings.
3	Machine voltage sensing input. Potential transformer required if line voltage exceeds 600 Vac.
4	Cross-current compensation input, 1 Aac or 5 Aac.
5	Connections required only if voltage matching or sync-check functions are used.
6	Labels indicate the functions assigned by the default programmable logic to the contact inputs and output contacts.
7	The Breaker Shunt Trip Output provides a switch capable of 100 mAdc to operate an external circuit breaker.
8	Type B USB jack for temporary, local communication. <div data-bbox="477 1142 1334 1325" style="border: 1px solid black; padding: 5px; margin-top: 10px;"> <p style="text-align: center; background-color: #FFD700; margin: 0;">Caution</p> <p>In accordance with the guidelines defined in USB standards, the USB port on this device is not isolated. To prevent damage to a connected PC or laptop, the DECS-150 must be properly tied to ground.</p> </div>
9	Ethernet communication port that uses the Modbus communication protocol.
10	The accessory input accepts voltage or current. Refer to the <i>Auxiliary Control</i> section for more information.
11	Bussmann type KTK-15 or equivalent fuses recommended.
12	CAN2 communication port used to communicate with a second DECS-150 for external tracking.

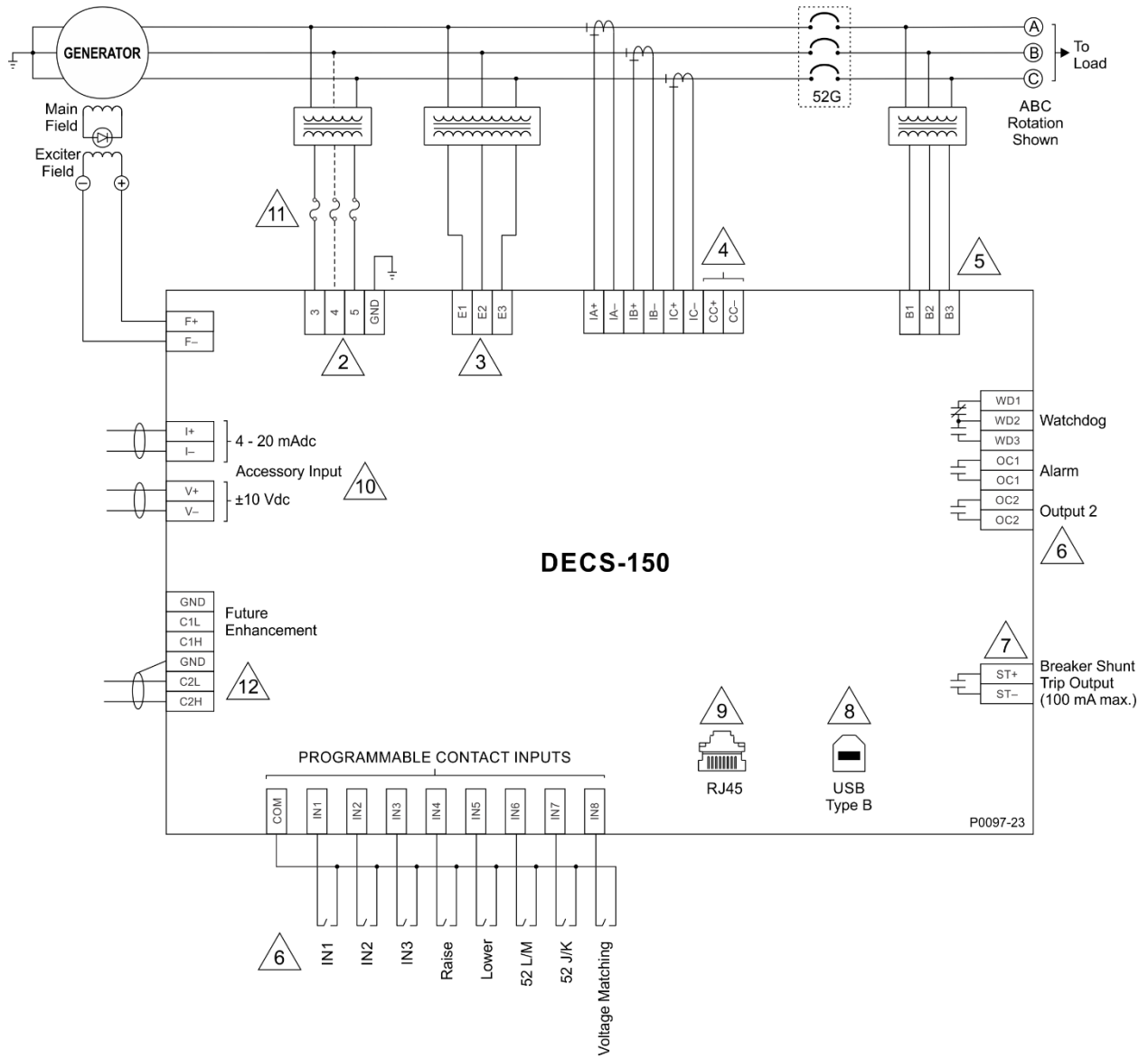


Figure 17-1. Typical DECS-150 Connections for Shunt Powered Generator Applications

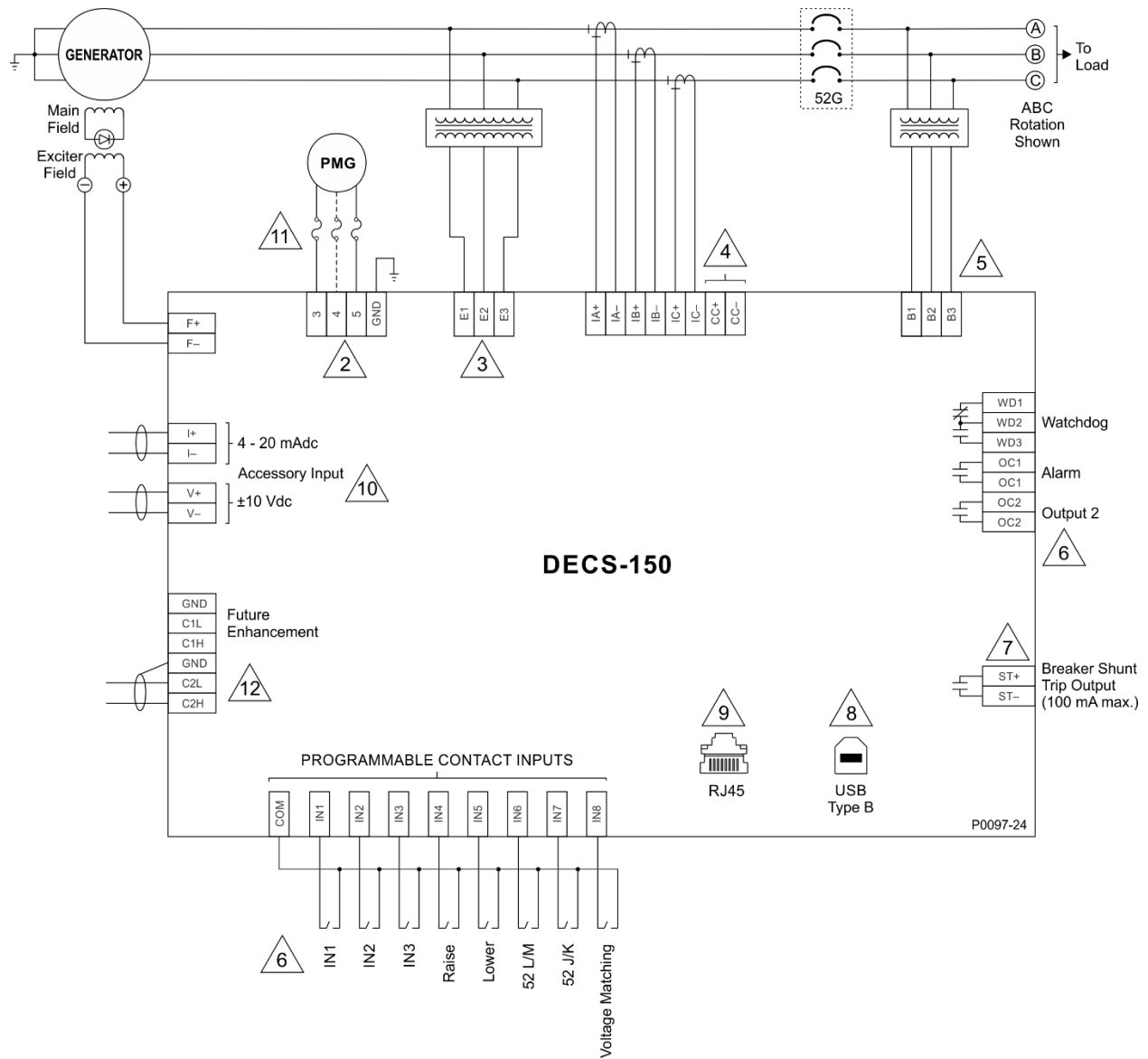


Figure 17-2. Typical DECS-150 Connections for PMG Powered Generator Applications

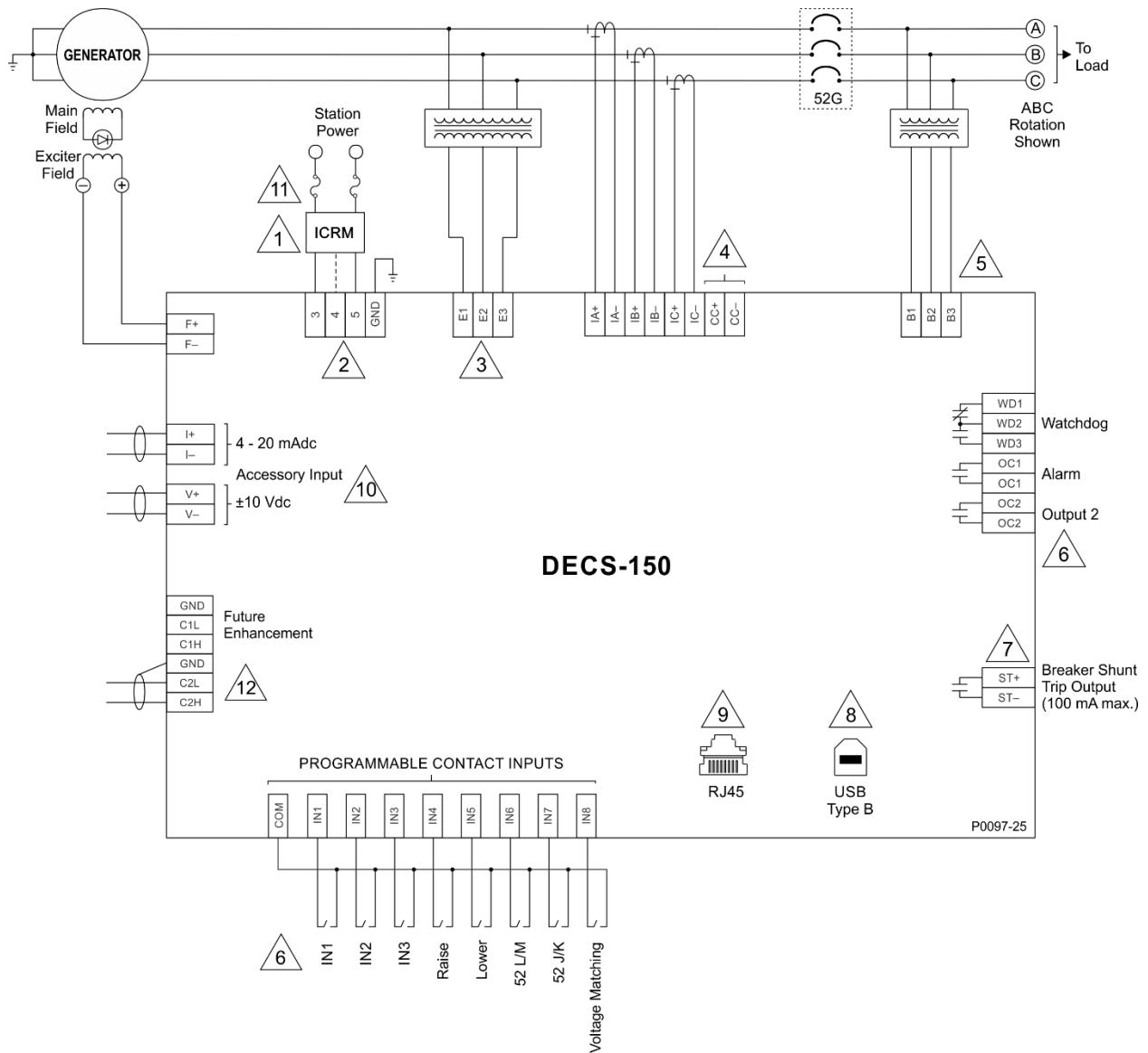


Figure 17-3. Typical DECS-150 Connections for Station Powered Generator Applications

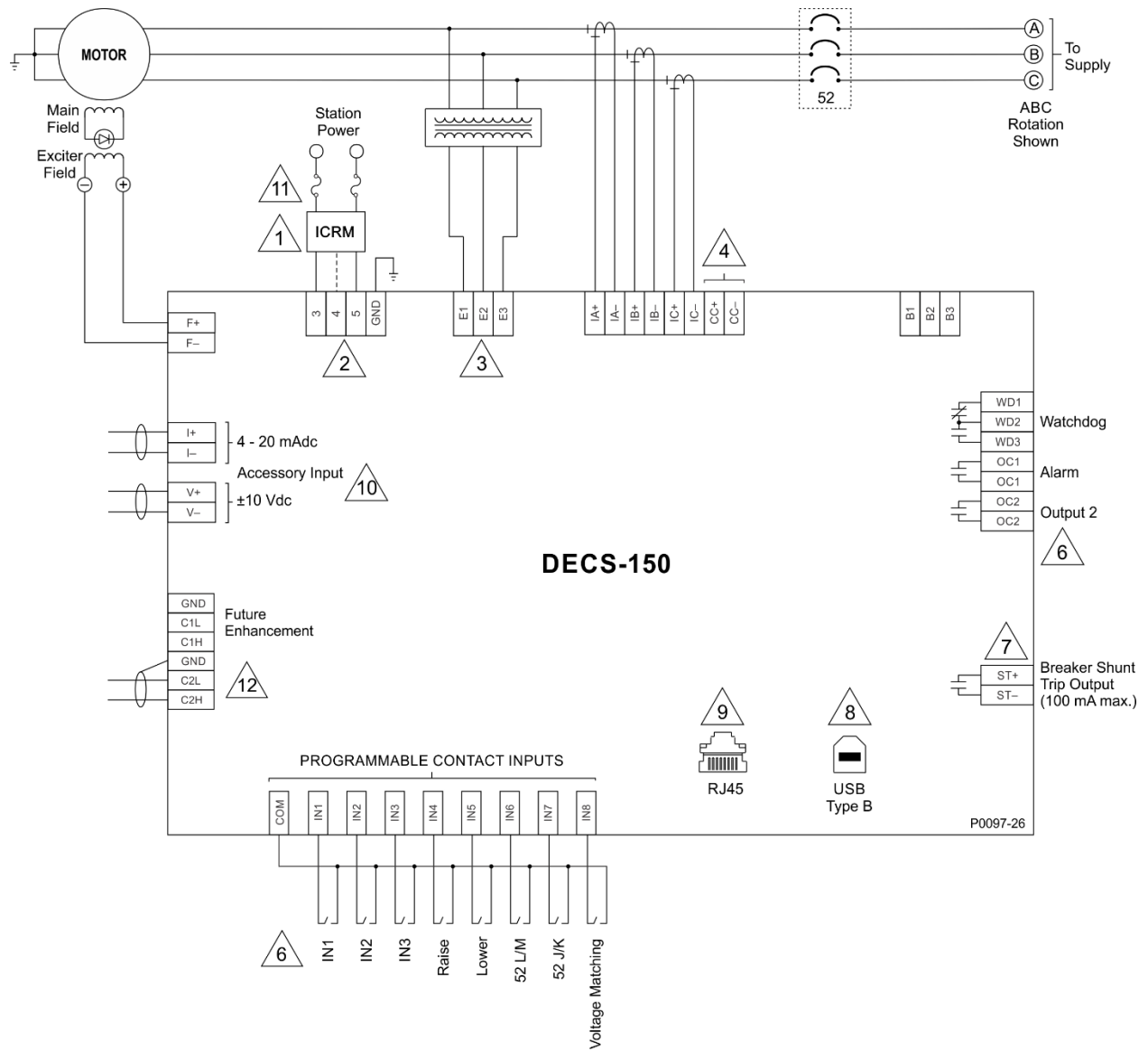


Figure 17-4. Typical DECS-150 Connections for Station Powered Motor Applications



18 • BESTCOMSP^{Plus}® Software

BESTCOMSP^{Plus}® is a Windows®-based, PC application that provides a user-friendly, graphical user interface (GUI) for use with Basler Electric communicating products. The name BESTCOMSP^{Plus} is an acronym that stands for Basler Electric Software Tool for Communications, Operations, Maintenance, and Settings.

BESTCOMSP^{Plus} provides the user with a point-and-click means to set and monitor the DECS-150. The capabilities of BESTCOMSP^{Plus} make the configuration of one or several DECS-150 controllers fast and efficient. A primary advantage of BESTCOMSP^{Plus} is that a settings scheme can be created, saved as a file, and then uploaded to the DECS-150 at the user's convenience.

BESTCOMSP^{Plus} uses plugins allowing the user to manage several different Basler Electric products. The DECS-150 plugin opens inside the BESTCOMSP^{Plus} main shell.

The same default logic scheme that is shipped with the DECS-150 is brought into BESTCOMSP^{Plus} by downloading settings and logic from the DECS-150. This gives the user the option of developing a custom setting file by modifying the default logic scheme or by building a unique scheme from scratch.

BESTlogic™^{Plus} Programmable Logic is used to program DECS-150 logic for protection elements, inputs, outputs, alarms, etc. This is accomplished by the drag-and-drop method. The user can drag elements, components, inputs, and outputs onto the program grid and make connections between them to create the desired logic scheme.

BESTCOMSP^{Plus} also allows for downloading industry-standard COMTRADE files for analysis of stored oscillography data. Detailed analysis of the oscillography files can be accomplished using BESTwave™ software.

Figure 18-1 illustrates the typical user interface components of the DECS-150 plugin with BESTCOMSP^{Plus}.

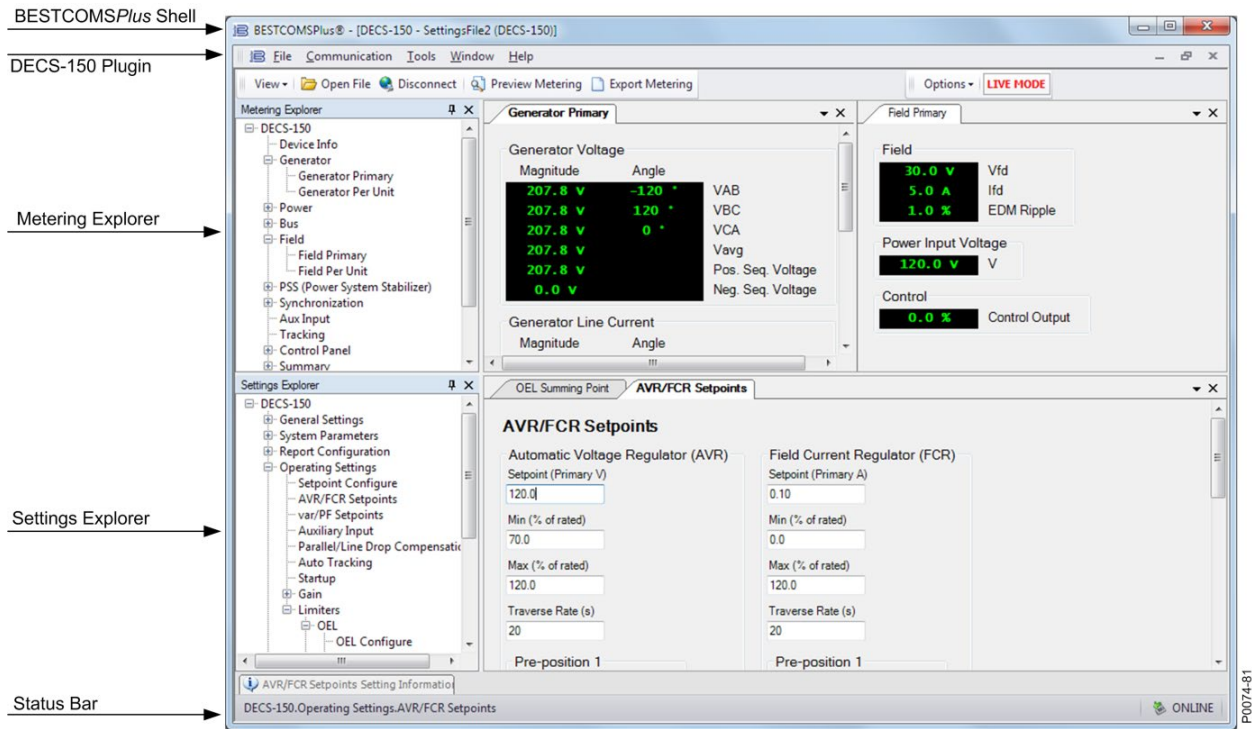


Figure 18-1. Typical User Interface Components

Installation

BESTCOMSPPlus software is built on the Microsoft® .NET Framework. The setup utility that installs BESTCOMSPPlus on your PC also installs the DECS-150 plugin and the required version of .NET Framework (if not already installed). BESTCOMSPPlus operates with systems using Windows® 7 SP1, Windows 8.1, Windows 10 version 1607 (Anniversary Edition) or later, and Windows 11. System recommendations for the .NET Framework and BESTCOMSPPlus are listed in Table 18-1.

Table 18-1. System Recommendations for BESTCOMSPPlus and the .NET Framework

System Type	Component	Recommendation
32/64 bit	Processor	2.0 GHz
32/64 bit	RAM	1 GB minimum, 2 GB recommended
32/64 bit	Hard Drive	200 MB (if .NET Framework is already installed on PC.)
		4.5 GB (if .NET Framework is not already installed on PC.)

To install and run BESTCOMSPPlus, a Windows user must have Administrator rights. A Windows user with limited rights may not have sufficient access to save files in certain folders.

Install BESTCOMSPPlus

Note

Do not connect a USB cable until setup completes successfully. Connecting a USB cable before setup is complete may result in unwanted or unexpected errors.

1. Download BESTCOMSPPlus from www.basler.com.

2. Click the installation button for *BESTCOMSPi.us*. The setup utility installs *BESTCOMSPi.us*, the .NET Framework (if not already installed), the USB driver, and the DECS-150 plugin for *BESTCOMSPi.us* on your PC.

When *BESTCOMSPi.us* installation is complete, a Basler Electric folder is added to the Windows programs menu. This folder is accessed by clicking the Windows Start button and then accessing the Basler Electric folder in the Programs menu. The Basler Electric folder contains an icon that starts *BESTCOMSPi.us* when clicked.

Powering the DECS-150 through the USB Port

The DECS-150 can be partially powered from the USB port when no input power is applied. The following capabilities are functional in this mode:

- The settings interface will operate as expected.
- Settings and all reports can be downloaded from the unit.
- Settings and firmware can be uploaded to the unit.

The following capabilities will not function in this mode:

- Voltage regulation
- Ethernet communication
- Metering (including the alarm panel)

If the unit is partially powered by USB followed by application of input power, the USB connection may have to be re-established by removing and re-inserting the USB connector. Likewise, if a USB connection is established while input power is applied and input power is lost, the USB connection may have to be re-established by removing and re-inserting the USB connector.

Connect the DECS-150 and Start BESTCOMSPi.us®

The DECS-150 plugin is a module that runs inside the *BESTCOMSPi.us* shell. The DECS-150 plugin contains specific operational and logic settings for only the DECS-150.

Connect a USB Cable

The USB driver was copied to your PC during *BESTCOMSPi.us* installation and is installed automatically after powering the DECS-150. USB driver installation progress is shown in the Windows Taskbar area. Windows will notify you when installation is complete.

Connect a USB cable between the PC and your DECS-150. Apply operating power (per style chart in the *Introduction* section) to the DECS-150 at rear terminals 3, 4, and 5. Wait until the boot sequence is complete.

Caution

In accordance with the guidelines defined in USB standards, the USB port on this device is not isolated. To prevent damage to a connected PC or laptop, the DECS-150 must be properly tied to ground.

Note

In some instances, the Found New Hardware Wizard will prompt you for the USB driver. If this happens, direct the wizard to the following folder:

C:\Program Files\Basler Electric\USB Connect Driver\

Start BESTCOMSPi^{us}

To start BESTCOMSPi^{us}, click the Start button, point to Programs, Basler Electric, and then click the BESTCOMSPi^{us} icon. During initial startup, the BESTCOMSPi^{us} Select Language screen is displayed (Figure 18-2). You can choose to have this screen displayed each time BESTCOMSPi^{us} is started, or you can select a preferred language and this screen will be bypassed in the future. Click OK to continue. This screen can be accessed later by selecting Tools and Select Language from the menu bar.

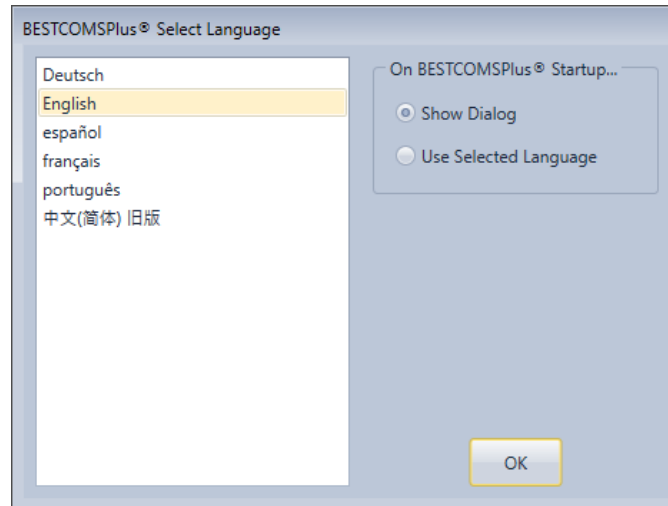


Figure 18-2. BESTCOMSPi^{us} Select Language Screen

The BESTCOMSPi^{us} platform window opens. Select New Connection from the Communication pull-down menu and select DECS-150. See Figure 18-3.

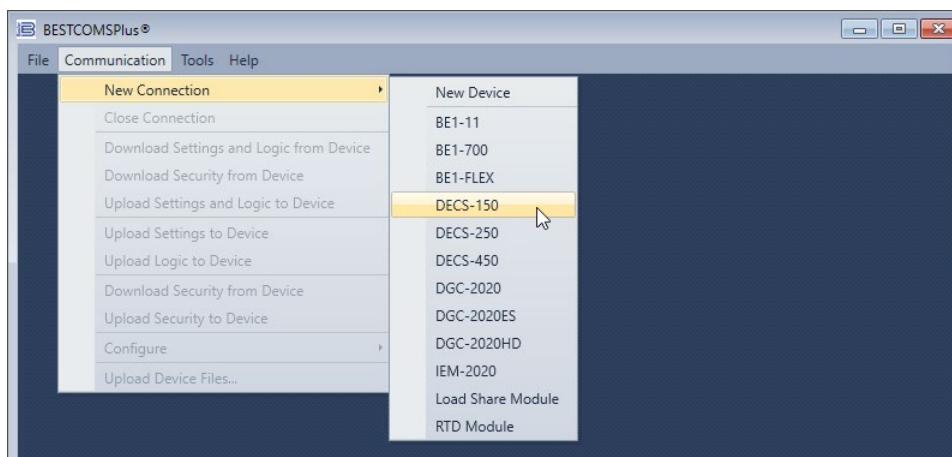


Figure 18-3. Communication Pull-Down Menu

The DECS-150 Connection screen shown in Figure 18-4 appears. Select USB Connection and click Connect.

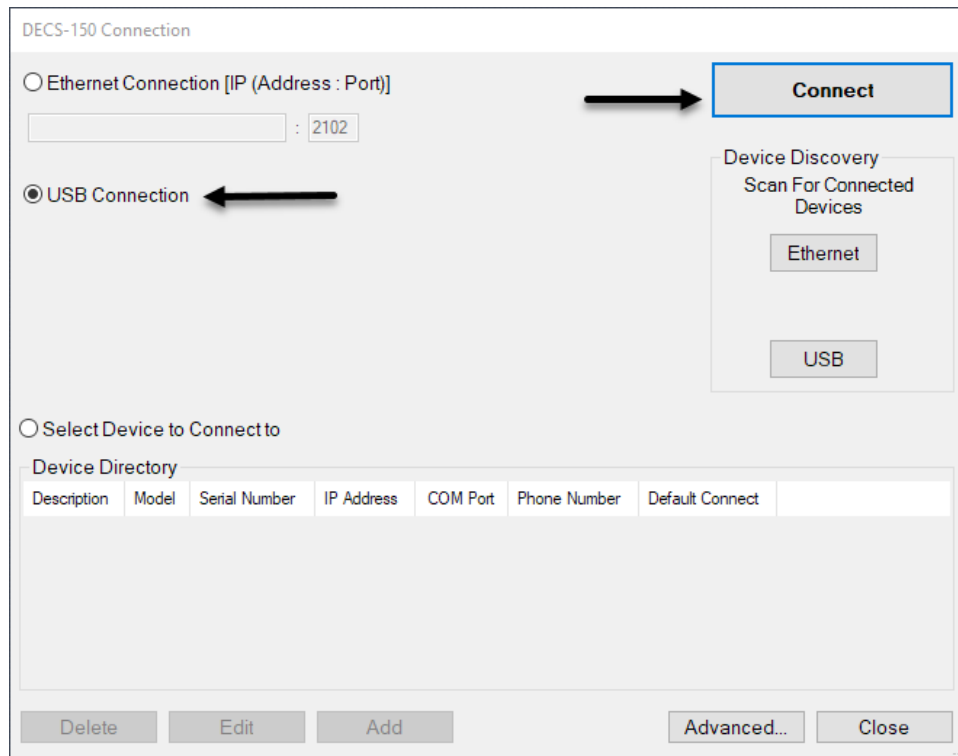


Figure 18-4. DECS-150 Connection Screen

Establishing Communication

Communication between BESTCOMSPi^{us} and the DECS-150 is established by clicking the Connect button on the DECS-150 Connection screen (see Figure 18-4) or by clicking the Connect button on the lower menu bar of the main BESTCOMSPi^{us} screen (Figure 18-1). If you receive an “Unable to Connect to Device” error message, verify that communications are configured properly. Only one Ethernet connection is allowed at one time. Download all settings and logic from the relay by selecting Download Settings and Logic from the Communication pull-down menu. BESTCOMSPi^{us} will read all settings and logic from the DECS-150 and load them into BESTCOMSPi^{us} memory.

Menu Bars

The menu bars are located near the top of the BESTCOMSPi^{us} screen (see Figure 18-1). The upper menu bar has five pull-down menus. With the upper menu bar, it is possible to manage settings files, configure communication settings, upload and download settings and security files, and compare settings files. The lower menu bar consists of clickable icons. The lower menu bar is used to change BESTCOMSPi^{us} views, open a settings file, connect/disconnect, preview metering printout, switch to live mode, and send settings after a change is made when not in live mode.

Upper Menu Bar (BESTCOMSPi^{us} Shell)

Upper menu bar functions are listed and described in Table 18-2.

Table 18-2. Upper Menu Bar (BESTCOMSPi^{us}® Shell)

Menu Item	Description
<i>File</i>	
New	Create a new settings file
Open	Open an existing settings file
Open File As Text	Generic file viewer for *.csv, *.txt, etc. files
Close	Close settings file

Menu Item	Description
Save	Save settings file
Save As	Save settings file with a different name
Export To File	Save settings as a *.csv file
Print	Open the print menu
Properties	View properties of a settings file
History	View history of a settings file
Recent Files	Open a previously opened file
Exit	Close BESTCOMSPlus program
<u>Communication</u>	
New Connection	Choose new device or DECS-150
Close Connection	Close communication between BESTCOMSPlus and DECS-150
Download Settings and Logic from Device	Download operational and logic settings from the device
Upload Settings and Logic to Device	Upload operational and logic settings to the device
Upload Settings to Device	Upload operational settings to the device
Upload Logic to Device	Upload logic settings to the device
Download Security from Device	Download security settings from the device
Upload Security to Device	Upload security settings to the device
Configure	Ethernet settings
Upload Device Files	Upload firmware to the device
<u>Tools</u>	
Select Language	Select BESTCOMSPlus language
Set File Password	Password protect a settings file
Compare Settings Files	Compare two settings files
Auto Export Metering	Exports metering data on a user-defined interval
Event Log - View	View the BESTCOMSPlus event log
Event Log - Verbose Logging	Enable/disable verbose logging
Event Log - Verbose Communication Logging	Enable/disable verbose communication logging
Set Default Shell	Select the default product shell view for BESTCOMSPlus. Options include Classic view, Updated view, or Combined view.
Generate Certificate (this function is not applicable to the DECS-150)	Generate a certificate
Accepted Devices (this function is not applicable to the DECS-150)	View and delete accepted devices
<u>Help</u>	
Check for Updates	Check for BESTCOMSPlus updates via the internet
Check for Update Settings	Enable or change automatic checking for updates
About	View general, detailed build, and system information

Lower Menu Bar (DECS-150 Plugin)

Lower menu bar functions are listed and described in Table 18-3.

Table 18-3. Lower Menu Bar (DECS-150 Plugin)

Menu Button	Description
View	Enables you to view the Metering Panel, Settings Panel, or Show Settings Information. Opens and saves workspaces. Customized workspaces make switching between tasks easier and more efficient.
Open File	Opens a saved settings file.
Connect/Disconnect	Opens the DECS-150 Connection screen, which enables you to connect to the DECS-150 via USB or Ethernet. Also used to disconnect a connected DECS-150.
Preview Metering	Displays the Print Preview screen where a preview of the Metering printout is shown. Click on the printer button to send to a printer.
Export Metering	Enables all metering values to be exported into a *.csv file.
Options	Displays a drop-down list entitled Live Mode Settings, which enables Live mode where settings are automatically sent to the device in real time as they are changed.
Send Settings	Sends settings to the DECS-150 when BESTCOMSP <i>lus</i> is not operating in Live Mode. Click on this button after making a setting change to send the modified setting to the DECS-150.

Settings Explorer

The BESTCOMSP*lus* settings explorer is used to navigate through the settings screens of the DECS-150 plugin. Descriptions of these configuration settings are organized as follows:

- General Settings
- Communications
- System Parameters
- Report Configuration
- Operating Settings
- PSS
- Voltage Matching
- Grid Code Settings
- Protection
- Programmable Inputs
- Programmable Outputs
- Alarm Configuration
- BESTlogicP*lus* Programmable Logic

Logic setup will be necessary after making certain setting changes. For more information, refer to the BESTlogicP*lus* section.

Settings Entry

When entering settings in BESTCOMSP*lus*, each setting is validated against prescribed limits. Entered settings that do not conform with the prescribed limits are accepted but flagged as noncompliant. Figure 18-5 illustrates an example of flagged, noncompliant settings (locator A) and the Setting Validation window (locator B) used to diagnose faulty settings.

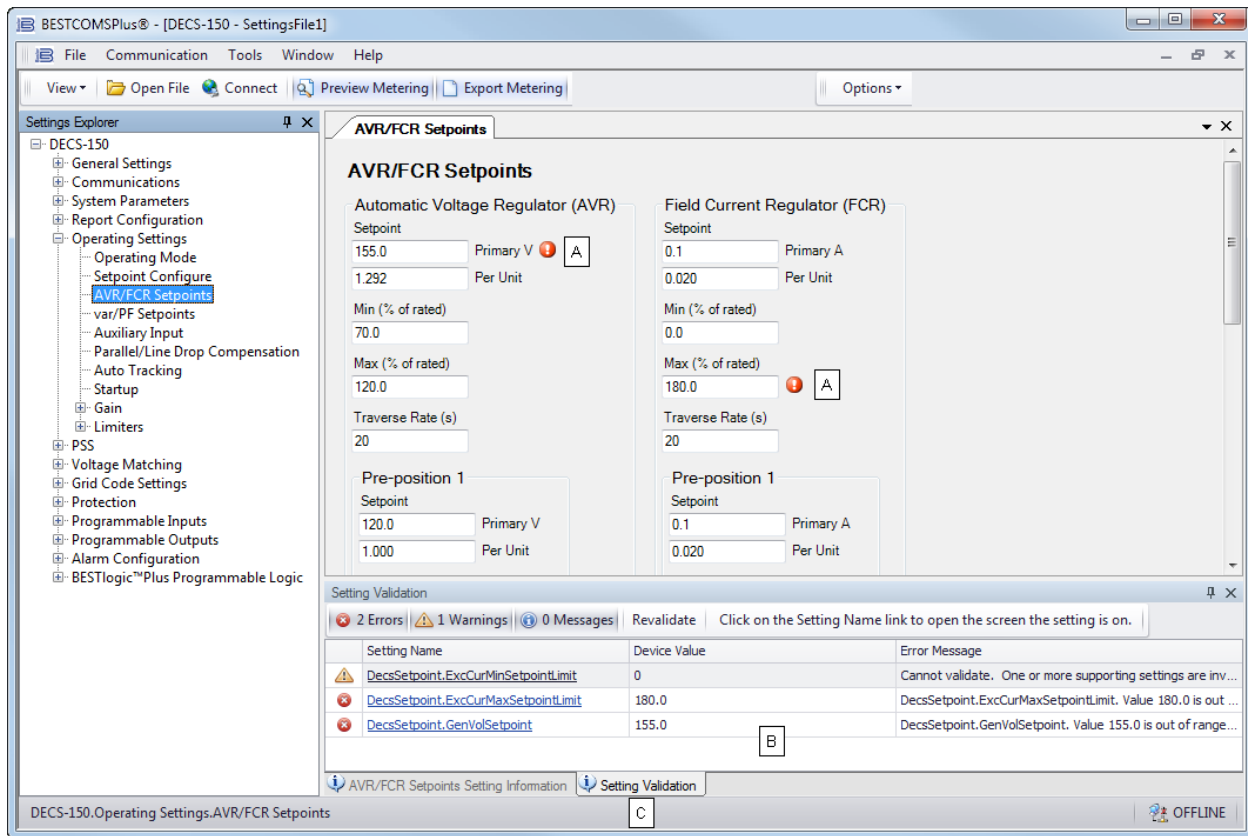


Figure 18-5. Flagged, Noncompliant Settings and the Setting Validation Window

The Setting Validation window, viewed by selecting the Setting Validation tab (locator C), displays three types of annunciations: errors, warnings, and messages. An error describes a problem such as a setting that is out of range. A warning describes a condition where supporting settings are invalid, causing other settings to be noncompliant with the prescribed limits. A message describes a minor setting issue that was automatically resolved by BESTCOMSPPlus. An example of a condition triggering a message is entry of a settings value with a resolution that exceeds the limit imposed by BESTCOMSPPlus. In this situation, the value is automatically rounded and a message is triggered. Each annunciation lists a hyperlinked name for the noncompliant setting and an error message describing the issue. Clicking the hyperlinked setting name takes you to the setting screen with the offending setting. Right-clicking the hyperlinked setting name will restore the setting to its default value.

Note

It is possible to save a DECS-150 settings file in BESTCOMSPPlus with noncompliant settings. However, it is not possible to upload noncompliant settings to the DECS-150.

Metering Explorer

The Metering Explorer is used to view real-time system data including machine voltages and currents, input/output status, alarms, reports, and other parameters. Refer to the *Metering* section for full details about the Metering Explorer.

Settings File Management

Caution

This product contains one or more *nonvolatile memory* devices. Nonvolatile memory is used to store information (such as settings) that needs to be preserved when the product is power-cycled or otherwise restarted. Established nonvolatile memory technologies have a physical limit on the number of times they can be erased and written. In this product, the limit is 100,000 erase/write cycles. During product application, consideration should be given to communications, logic, and other factors that may cause frequent/repeated writes of settings or other information that is retained by the product. Applications that result in such frequent/repeated writes may reduce the useable product life and result in loss of information and/or product inoperability.

A settings file contains all DECS-150 settings including logic.

A settings file created in *BESTCOMSPPlus* will have one of two file extensions. Settings files created in version 4.00.00 and later are given an extension of “bst4”. Settings files created in versions prior to 4.00.00 will have an extension of “bstx”.

It is possible to save only the DECS-150 logic displayed on the *BESTlogicPlus* Programmable Logic screen as a separate logic library file. This ability is helpful when similar logic is required for several DECS-150 systems. The file extension of a logic file created in *BESTCOMSPPlus* will be either “bsl4” (version 4.00.00 and later) or “bslx” (versions prior to 4.00.00).

It is important to note that settings and logic can be uploaded to the device separately or together, but are always downloaded together. For more information on logic files, refer to the *BESTlogicPlus* section.

Opening a Settings File

To open a DECS-150 settings file with *BESTCOMSPPlus*, pull down the File menu and choose Open. The Open dialog box appears. This dialog box allows you to use normal Windows techniques to select the file that you want to open. Select the file and choose Open. You can also open a file by clicking on the Open File button on the lower menu bar. If connected to a device, you will be asked to upload the settings and logic from the file to the current device. If you choose Yes, the settings displayed in *BESTCOMSPPlus* instance will be overwritten with the settings of the opened file.

Saving a Settings File

Select Save or Save As from the File pull-down menu. A dialog box prompts you to enter a filename and location to save the file. Select the Save button to complete the save.

Upload Settings and/or Logic to Device

To upload a settings file to the DECS-150, open the file or create a new file through *BESTCOMSPPlus*. Then pull down the Communication menu and select Upload Settings and Logic to Device. If you want to upload operational settings without logic, select Upload Settings to Device. If you want to upload logic without operational settings, select Upload Logic to Device. You are prompted to enter the username and password. The default username is “A” and the default password is “A”. If the username and password are correct, the upload begins and the progress bar is shown.

Download Settings and Logic from Device

To download settings and logic from the DECS-150, pull down the Communication menu and select Download Settings and Logic from Device. If the settings in *BESTCOMSPPlus* have changed, a dialog box will open asking if you want to save the current settings changes. You can choose Yes or No. After you have taken the required action to save or discard the current settings, downloading begins. *BESTCOMSPPlus* reads all settings and logic from the DECS-150 and loads them into *BESTCOMSPPlus* memory.

Printing a Settings File

To view a preview of the settings printout, select Print from the File pull-down menu. To print the settings, select the printer icon in the upper left corner of the Print Preview screen.

Comparing Settings Files

BESTCOMSP*l*us has the ability to compare two settings files. To compare files, pull down the Tools menu and select Compare Settings Files. The BESTCOMSP*l*us Settings Compare Setup dialog box appears (Figure 18-6). Select the location of the first file under Left Settings Source and select the location of the second file under Right Settings Source. If you are comparing a settings file located on your PC hard drive or portable media, click the folder button and navigate to the file. If you want to compare settings downloaded from a unit, click the Select Unit button to set up the communication port. Click the Compare button to compare the selected settings files.

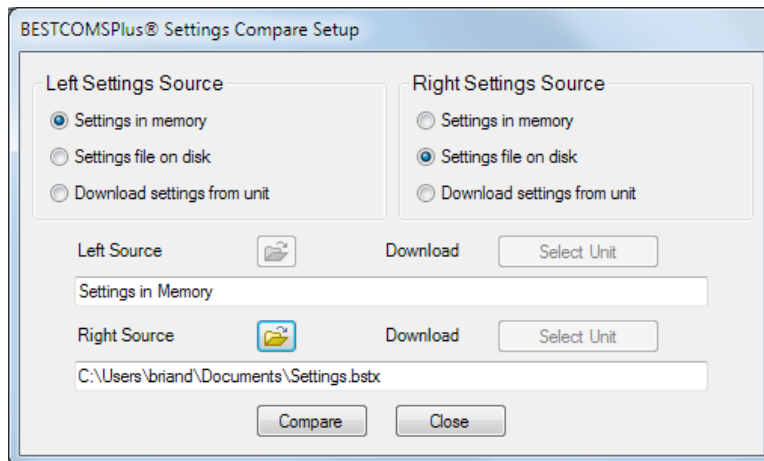


Figure 18-6. BESTCOMSP*l*us Settings Compare Setup

A dialog box will appear and notify you if any differences were found. The BESTCOMSP*l*us Settings Compare dialog box (Figure 18-7) is displayed where you can view all settings (Show All Settings), view only the differences (Show Settings Differences), view all logic (Show All Logic Paths), or view only logic differences (Show Logic Path Differences). Select Close when finished.

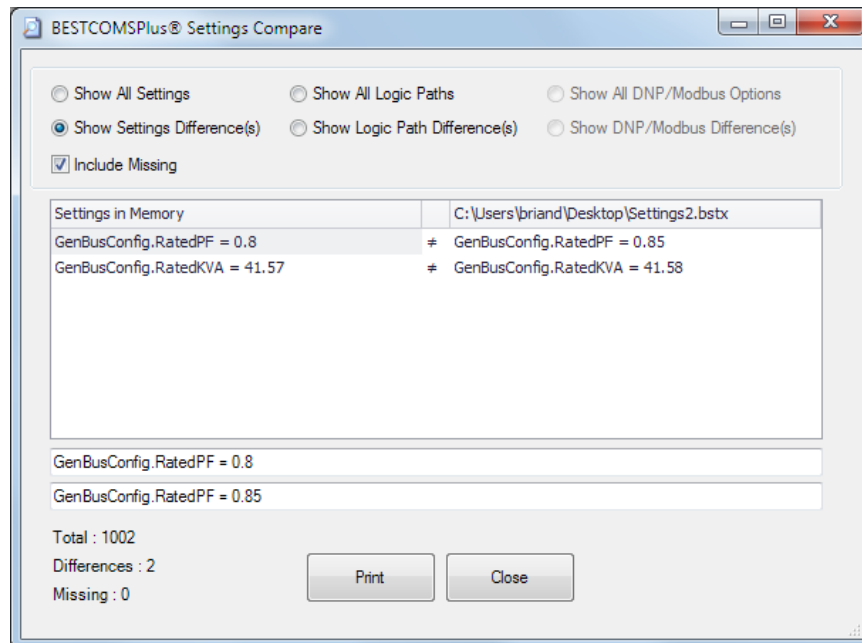


Figure 18-7. BESTCOMSP*l*us Settings Compare

Firmware Updates

Future enhancements to DECS-150 functionality will require a firmware update. Because default settings are loaded when DECS-150 firmware is updated, your settings should be saved in a file prior to upgrading firmware.

Warning!

Before performing any maintenance procedures, remove the DECS-150 from service. Refer to the appropriate site schematics to ensure that all steps have been taken to properly and completely de-energize the DECS-150.

Caution – Settings will be lost!

Default settings will be loaded into the DECS-150, and reports and events will be cleared when firmware is updated. BESTCOMSP^{Plus} can be used to download settings and save the settings in a file so that they can be restored after updating firmware. Refer to *Settings File Management* for help with saving a settings file.

Notes

Firmware upgrades from version 1.xx.xx to 2.xx.xx cannot be performed using BESTCOMSP^{Plus}. The DECS-150 must be sent to Basler Electric to perform the upgrade. Contact technical support for more information.

The latest version of BESTCOMSP^{Plus} software should be downloaded from the Basler Electric website and installed before performing a firmware upgrade.

A device package contains firmware for the DECS-150. Embedded firmware is the operating program that controls the actions of the DECS-150. The DECS-150 stores firmware in nonvolatile memory that can be reprogrammed through the communication ports.

Notes

When performing a firmware upgrade, only one DECS-150 can be connected to the PC through USB. If a firmware upgrade is initiated when more than one unit is connected through USB, communication will be lost after the unit reboots.

If USB communication is interrupted during file transfer to the DECS-150, the firmware upload will fail. Once communication has been restored, the user must start the firmware upload again. Select Upload Device Files from the Communication pull-down menu and proceed normally.

Upgrading Firmware in the DECS-150

The following procedure is used to upgrade firmware in the DECS-150.

1. Remove the DECS-150 from service. Refer to the appropriate site schematics to ensure that all steps have been taken to properly and completely de-energize the DECS-150.
2. Connect to the DECS-150 with BESTCOMSP*lus* through the USB port. Check the firmware Application Version on the General Settings > Device Info screen.
3. Select Upload Device Files from the Communication pull-down menu. Save settings when prompted, if desired.
4. Open the desired device package file (decs-150.bef).
5. Check the box for DECS-150 Firmware as shown in Figure 18-8. Note the version number of the DECS-150 firmware; this is the version that will be used to set the Application Version in the settings file in a later step.
6. Click the Upload button and follow the instructions that appear to begin the upgrade process.
7. After the upload is complete, disconnect communication to the DECS-150.
8. Load the saved settings file into the DECS-150.
 - a. Close all settings files.
 - b. From the File pull-down menu, select New, DECS-150.
 - c. Connect to the DECS-150.
 - d. Once all settings have been read from the DECS-150, open the saved settings file by selecting File, Open File in the BESTCOMSP*lus* menu. Then browse for the file to upload.
 - e. When BESTCOMSP*lus* asks if you wish to upload settings and logic to the device, click Yes.
 - f. If you receive upload failures and indications that the logic is incompatible with the firmware version, check that the DECS-150 style number in the saved file matches that of the DECS-150 into which the file is being uploaded. The style number in the settings file is found under General Settings > Style Number in BESTCOMSP*lus*.
 - g. If the style number of the settings file does not match that of the DECS-150 into which it is to be loaded, disconnect from the DECS-150, then modify the style number in the settings file. Then repeat the steps titled *Load the Saved Settings File into the DECS-150*.

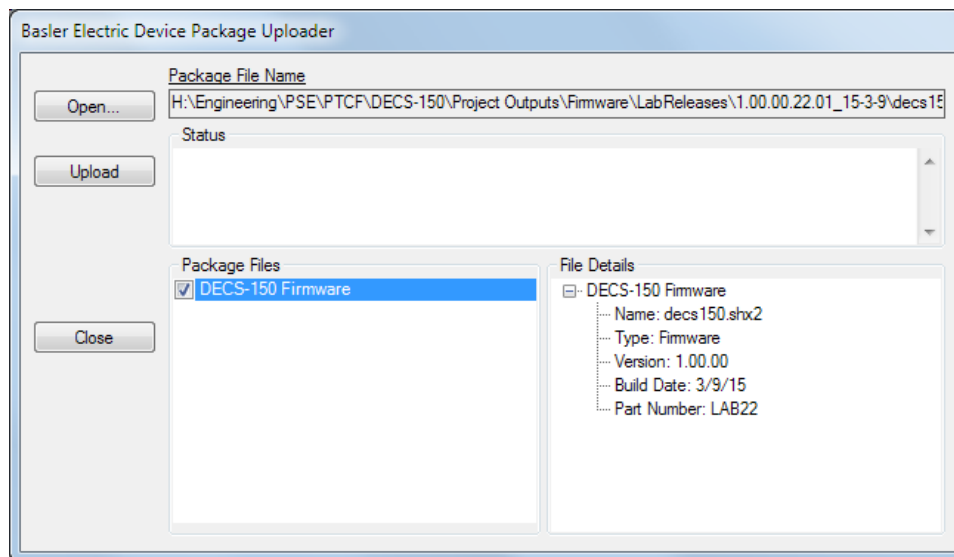


Figure 18-8. Device Package Uploader Screen

BESTCOMSPi[®] *Updates*

Enhancements to DECS-150 firmware typically coincide with enhancements to the DECS-150 plugin for *BESTCOMSPi*. When a DECS-150 is updated with the latest version of firmware, the latest version of *BESTCOMSPi* should also be obtained.

- You can download the latest version of *BESTCOMSPi* by visiting www.basler.com.
- *BESTCOMSPi* automatically checks for updates when Check Automatically is selected on the Check for Updates User Settings screen. This screen is accessed under the Help drop-down menu. (An internet connection is required.)
- You can use the manual “check for updates” function in *BESTCOMSPi* to ensure that the latest version is installed by selecting Check for Updates in the Help drop-down menu. (An internet connection is required.)



19 • BESTlogic™ Plus

Caution

This product contains one or more *nonvolatile memory* devices. Nonvolatile memory is used to store information (such as settings) that needs to be preserved when the product is power-cycled or otherwise restarted. Established nonvolatile memory technologies have a physical limit on the number of times they can be erased and written. In this product, the limit is 100,000 erase/write cycles. During product application, consideration should be given to communications, logic, and other factors that may cause frequent/repeated writes of settings or other information that is retained by the product. Applications that result in such frequent/repeated writes may reduce the useable product life and result in loss of information and/or product inoperability.

Introduction

BESTlogic™ Plus Programmable Logic is a programming method used for managing the input, output, protection, control, monitoring, and reporting capabilities of Basler Electric's DECS-150 Digital Excitation Control System. Each DECS-150 has multiple, self-contained logic blocks that have all of the inputs and outputs of its discrete component counterpart. Each independent logic block interacts with control inputs and hardware outputs based on logic variables defined in equation form with BESTlogic Plus. BESTlogic Plus equations entered and saved in the DECS-150 system's nonvolatile memory integrate (electronically wire) the selected or enabled protection and control blocks with control inputs and hardware outputs. A group of logic equations defining the logic of the DECS-150 is called a logic scheme.

Two default active logic schemes are preloaded into the DECS-150. One default logic scheme is tailored for a system with the PSS option disabled and the other is for a system with PSS enabled. The proper default logic scheme is loaded depending on the PSS option selected in the system style number. These schemes are configured for a typical protection and control application of a synchronous machine and virtually eliminate the need for "start-from-scratch" programming. The default logic schemes are configured to provide functionality similar to that of a DECS-100. BESTCOMSPPlus® can be used to open a logic scheme that was previously saved as a file and upload it to the DECS-150. The default logic schemes can also be customized to suit your application. Detailed information about logic schemes is provided later in this section.

BESTlogic Plus is not used to define the operating settings (modes, pickup thresholds, and time delays) of the individual protection and control functions. Operating settings and logic settings are interdependent but separately programmed functions. Changing logic settings is similar to rewiring a panel and is separate and distinct from making the operating settings that control the pickup thresholds and time delays of a DECS-150. Detailed information about operating settings is provided in other sections of this instruction manual.

Overview of BESTlogic™ Plus

Use BESTCOMSPPlus to make BESTlogic Plus settings. Use the Settings Explorer to open the BESTlogic Plus Programmable Logic tree branch as shown in Figure 19-1.

The BESTlogic Plus Programmable Logic screen contains a logic library for opening and saving logic files, tools for creating and editing logic documents, and logic protection settings.

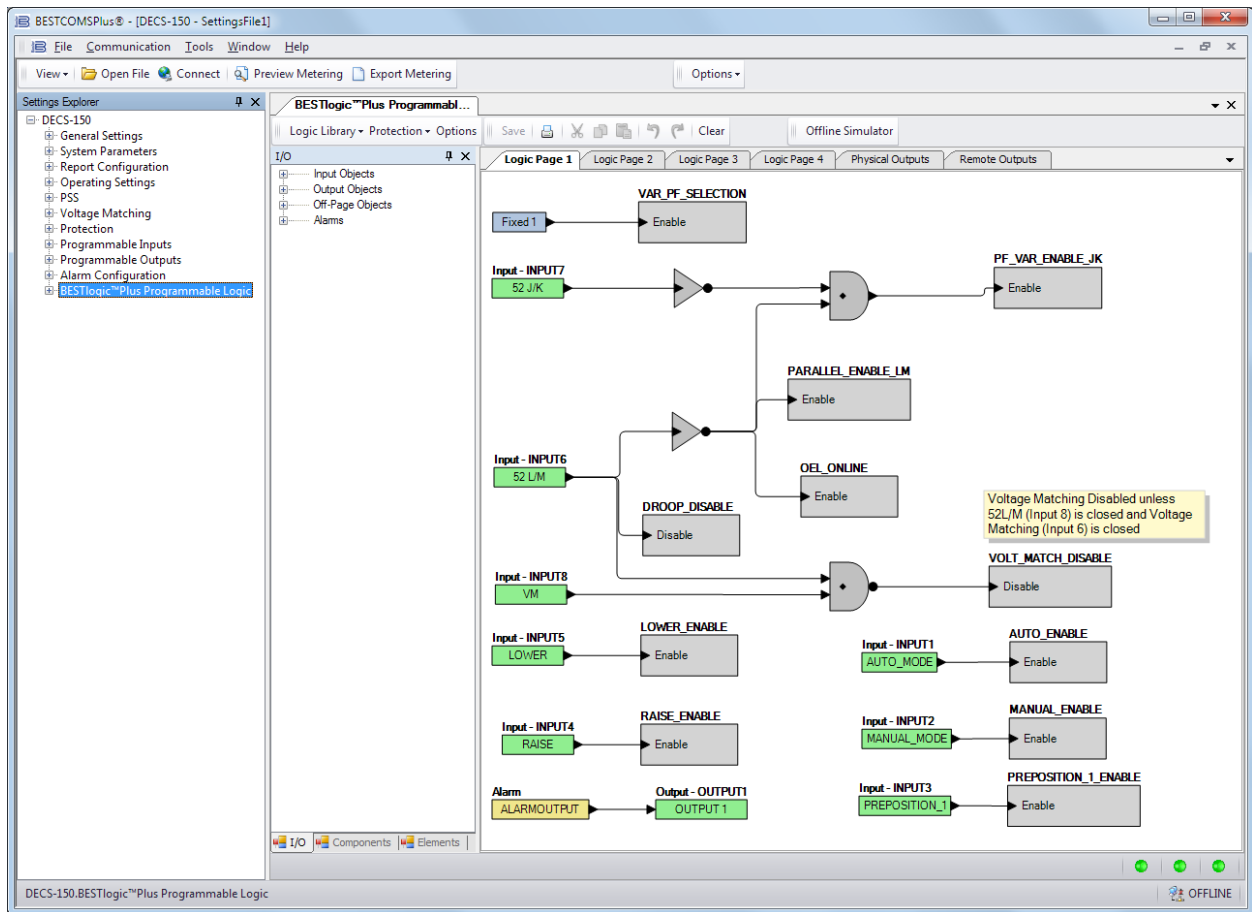


Figure 19-1. BESTlogicPlus Programmable Logic Tree Branch

BESTlogicPlus Composition


















There are three main groups of objects used for programming BESTlogicPlus. These groups are I/O, Components, and Elements. For details on how these objects are used to program BESTlogicPlus, see the paragraphs on *Programming BESTlogicPlus*.

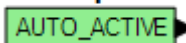
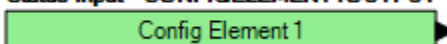
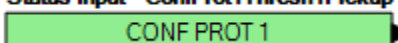

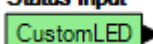
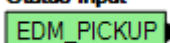
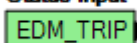
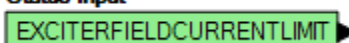
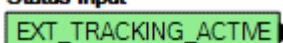
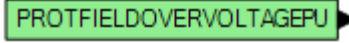
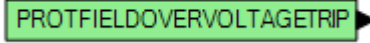
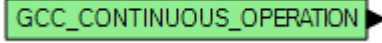
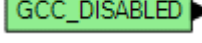
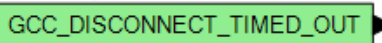
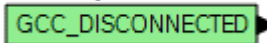
I/O

This group contains Input Objects, Output Objects, Off-Page Objects, and Alarms. Table 19-1 lists the names and descriptions of the objects in the I/O group.

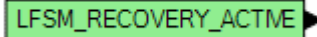
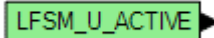
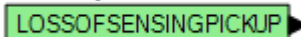
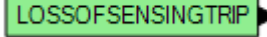
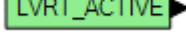
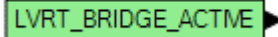
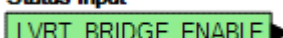
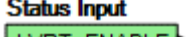

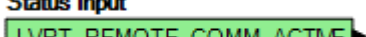
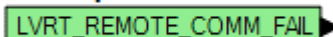

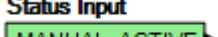
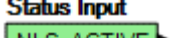
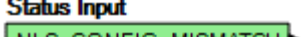
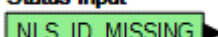
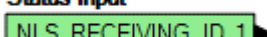
Table 19-1. I/O Group, Names and Descriptions

Name	Description	Symbol
Input Objects		
Logic 0	Always false (Low).	
Logic 1	Always true (High).	
<i>Physical Inputs</i>		
IN1 - IN8	True when Physical Input x is active.	
<i>Virtual Inputs</i>		
VIN1 - VIN6	True when Virtual Input x is active.	

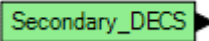
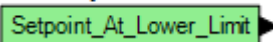
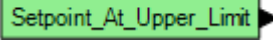
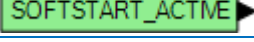
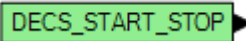
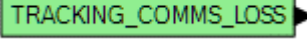
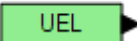
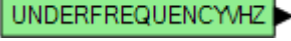
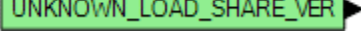
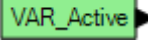
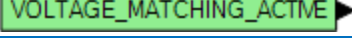
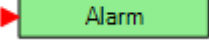
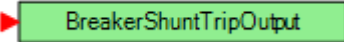
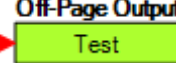
Name	Description	Symbol
<i>Status Inputs</i>		
25 Sync Status	True when the machine/bus differences fall within the setting for each parameter.	Status Input PROTECTION25STATUS 
27 Undervoltage Pickup	True when the undervoltage pickup threshold is exceeded and the element is timing towards a trip.	Status Input PROTECTION27PICKUP 
27 Undervoltage Trip	True when the undervoltage pickup threshold is exceeded for the duration of the time delay.	Status Input PROTECTION27TRIP 
59 Overvoltage Pickup	True when the overvoltage pickup threshold is exceeded and the element is timing towards a trip.	Status Input PROTECTION59PICKUP 
59 Overvoltage Trip	True when the overvoltage pickup threshold is exceeded for the duration of the time delay.	Status Input PROTECTION59TRIP 
81 Overfrequency Pickup	True when the overfrequency pickup threshold is exceeded and the element is timing towards a trip.	Status Input PROTECTION81OPICKUP 
81 Overfrequency Trip	True when the overfrequency pickup threshold is exceeded for the duration of the time delay.	Status Input PROTECTION81OTRIP 
81 Underfrequency Pickup	True when the underfrequency pickup threshold is exceeded and the element is timing towards a trip.	Status Input PROTECTION81UPICKUP 
81 Underfrequency Trip	True when the underfrequency pickup threshold is exceeded for the duration of the time delay.	Status Input PROTECTION81UTRIP 
APC Active	True when Active Power Control (APC) mode is active.	Status Input APC_ACTIVE 
APC Bridge Active	True when APC Bridge mode is active.	Status Input APC_BRIDGE_ACTIVE 
APC Bridge Enable	True when APC Bridge mode is enabled.	Status Input APC_BRIDGE_ENABLE 
APC Enable	True when APC mode is enabled.	Status Input APC_ENABLE 
APC Modbus Comm Fail	True when the APC Adjust Source setting is set to Modbus and the Remote Control Failure Timer has expired.	Status Input APC_MODBUS_COMM_FAIL 
APC Output Limit	True when the Active Power PI controller is at either its maximum or minimum output limit.	Status Input APC_OUTPUT_LIMIT 
APC Remote Comm Active	True while the Remote Control Failure Timer is active. The Remote Control Failure Timer is always active and resets frequently, during good communications.	Status Input APC_REMOTE_COMM_ACTME 
APC Remote Comm Fail	True when the Remote Control Failure Timer has expired for any communication protocol (defined by the Adjust Source setting).	Status Input APC_REMOTE_COMM_FAIL 

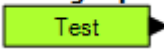
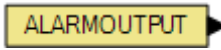
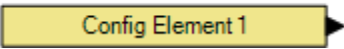
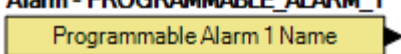
Name	Description	Symbol
Auto Mode Active	True when the unit is in Auto mode (AVR).	Status Input 
Configurable Elements 1-8	True when Configurable Element x is active.	Status Input - CONFIGELEMENT1OUTPUT 
Configurable Protection 1-8	<p>There are four thresholds for each of the eight Configurable Protection blocks. Each threshold can be set to Over or Under mode and the threshold limit and activation delay can each be set. See the <i>Protection</i> section in this manual for more details. Each threshold has a separate logic block for the pickup and the trip. Configurable Protection #1 with its Threshold #1 Pickup and Trip blocks is shown to the right. The pickup block is true when the threshold is exceeded. The trip block is true when the corresponding pickup block threshold is exceeded for the duration of the time delay.</p>	Status Input - ConfProt1Thresh1Pickup  Status Input - ConfProt1Thresh1Trip 
Custom LED	True when the Set input of the CUSTOM_LED logic element is true. Refer to the <i>Elements</i> section.	Status Input 
EDM Pickup	True when the EDM pickup threshold is exceeded and the element is timing towards a trip.	Status Input 
EDM Trip	True when the EDM pickup threshold is exceeded for the duration of the time delay.	Status Input 
Exciter Field Current Limit	True when the field current is too high, which could result in damage to the regulator. This condition also shuts down excitation. A restart is required to begin regulating again.	Status Input 
External Tracking Active	True when external tracking is running.	Status Input 
Field Overvoltage Pickup	True when the field overvoltage pickup threshold is exceeded and the element is timing towards a trip.	Status Input 
Field Overvoltage Trip	True when the field overvoltage pickup threshold is exceeded for the duration of the time delay.	Status Input 
GCC Continuous Operation	True when the controlled generator's frequency and voltage are within the Continuous Operation region for Grid Code Connectivity (GCC).	Status Input 
GCC Disabled	True when the GCC function is disabled.	Status Input 
GCC Disconnect Timed Out	<p>True when any Grid Code disconnection timer has expired.</p> <p>Remains true until the GCC reconnect timer becomes active.</p>	Status Input 
GCC Disconnected	True when disconnection criteria for GCC has been met and remains true until the GCC reconnect timer expires.	Status Input 

Name	Description	Symbol
GCC Freq High Timing	True when the controlled generator's frequency is in the high frequency region for GCC and the timer is active.	Status Input GCC_FREQ_HI_TIMING
GCC Freq Low Timing	True when the controlled generator's frequency is in the low frequency region for GCC and the timer is active.	Status Input GCC_FREQ_LOW_TIMING
GCC Out of Range Timing	True when the controlled generator's frequency or voltage is in the Out of Range region for GCC and the timer is active.	Status Input GCC_OUT_OF_RANGE_TIMING
GCC Timing for Disconnect	True when any of the GCC timers is active.	Status Input GCC_DISCONNECT_TIMING
GCC Timing for Reconnect	True when the GCC reconnect timer is active.	Status Input GCC_RECONNECT_TIMING
GCC Voltage High Timing	True when the controlled generator's voltage is in the high voltage region for GCC and the timer is active.	Status Input GCC_VOLTS_HIGH_TIMING
GCC Voltage Low Timing	True when the controlled generator's voltage is in the low voltage region for GCC and the timer is active.	Status Input GCC_VOLTS_LOW_TIMING
Generator/Motor Below 10 Hz Pickup	True when the machine is operating below 10 Hz and the element is timing towards a trip.	Status Input PROTECTGENBELOW10HZPICKUP
Generator/Motor 10 Hz Trip	True when the machine is operating below 10 Hz for 100 ms.	Status Input PROTECTGENBELOW10HZTRIP
Grid Code Enabled	True when the Grid Code Connectivity function is enabled.	Status Input GRIDCODE_ENABLED
Hardware Shutdown	True when a user-configured protection element or limiter causes a forced shutdown.	Status Input HardwareShutdown
Internal Tracking Active	True when internal tracking is running.	Status Input INT_TRACKING_ACTIVE
KW Threshold	True when kW output is below the standard (non-Grid Code) PF Active Power Level.	Status Input KW_THRESHOLD_STATUS
LFSM Active	True when Limited Frequency Sensitive Mode (LFSM) is active.	Status Input LFSM_ACTIVE
LFSM Enable	True when LFSM is enabled.	Status Input LFSM_ENABLE
LFSM Normal Operation	True when LFSM is enabled and grid frequency is within the dead band.	Status Input LFSM_NORMAL_OPERATION
LFSM Overfrequency Active	True when LFSM is enabled and grid frequency is greater than the LFSM-O Dead Band setting value.	Status Input LFSM_O_ACTIVE

Name	Description	Symbol
LFSM Recovery Active	True when LFSM is enabled and the Grid Recovery timer is active.	Status Input 
LFSM Underfrequency Active	True when LFSM is enabled and grid frequency is less than the LFSM-U Dead Band setting value.	Status Input 
Loss of Sensing Pickup	True when the Loss of Sensing pickup threshold is exceeded and the element is timing towards a trip.	Status Input 
Loss of Sensing Trip	True when the Loss of Sensing pickup threshold is exceeded for the duration of the time delay.	Status Input 
LVRT Active	True when Low Voltage Ride Through (LVRT) mode is active.	Status Input 
LVRT Bridge Active	True when LVRT Bridge mode is active.	Status Input 
LVRT Bridge Enable	True when LVRT Bridge mode is enabled.	Status Input 
LVRT Enable	True when LVRT mode is enabled.	Status Input 
LVRT Modbus Comm Fail	True when the LVRT Adjust Source setting is set to Modbus and the Remote Control Failure Timer has expired.	Status Input 
LVRT Remote Comm Active	True when the Remote Control Failure Timer is active. The Remote Control Failure Timer is always active and resets frequently, during good communications.	Status Input 
LVRT Remote Comm Fail	True when the Remote Control Failure Timer has expired for any communication protocol (defined by the Adjust Source setting).	Status Input 
LVRT Remote Fail Mode	True when LVRT remote communication has failed.	Status Input 
Manual Mode Active	True when the unit is in Manual mode (FCR).	Status Input 
Network Load Share Active	True when network load sharing is active.	Status Input 
Network Load Share Config Mismatch	True when the unit's configuration does not match the configuration of the other units with load sharing enabled.	Status Input 
Network Load Share ID Missing	True when any of the load sharing enabled units are not detected on the network.	Status Input 
Network Load Share Receiving ID 1-16	True when data is being received from a specific unit on the load share network.	Status Input 

Name	Description	Symbol
No Network Load Share Data Received	True when Network Load Sharing is enabled but there is no data being received from other network load sharing devices.	Status Input NO_NETWORK_LOADSHARE_DATA
Network Load Share Status 1-4	This element functions in conjunction with the Network Load Share Broadcast elements on all units on the network. True when the corresponding Network Load Share Broadcast element input is true on another unit on the network.	Status Input NLS_STATUS_1
Network Overload	True when there are too many packets being sent and the Ethernet is overloaded. When true, Ethernet is disabled, but regulation continues.	Status Input NETWORK_OVERLOAD
Null Balance	True when Null Balance is achieved in both external and internal tracking.	Status Input NULL_BALANCE
OEL	True when the Overexcitation Limiter is active.	Status Input OEL
PF Controller Active	True when the unit is in PF mode.	Status Input PF_Active
Power Supply Low Alarm	True when power input voltage is below normal operating range.	Status Input PowerSupplyLow_ALM
Pre-Position Active	True when any pre-position is active.	Status Input DECS_PREPOSITION
Pre-Position 1-3 Active	True when Pre-Position x is active.	Status Input PREPOSITION_1_ACTME
PSS Active (Optional)	True when the power system stabilizer (PSS) is turned on and running.	Status Input PSS_ACTIVE
PSS Current Unbalanced (Optional)	True when the phase current is unbalanced and the PSS is active.	Status Input PSSCURRENTUNBALANCED
PSS Power Below Threshold (Optional)	True when the input power is below the Power Level threshold and the PSS is active.	Status Input PSSPOWERBELOWTHRESHOLD
PSS Secondary Group (Optional)	True when the PSS is using secondary settings.	Status Input PSS_USING_SEC_SETTINGS
PSS Speed Failed (Optional)	True when the frequency is out of range for a length of time calculated internally by the DECS-150 and the PSS is active.	Status Input PSSSPEEDFAILED
PSS Test On (Optional)	True when the power system stabilizer test signal (Frequency Response) is active.	Status Input PSS_TEST_MODE
PSS Voltage Limit (Optional)	True when the calculated terminal voltage upper or lower limit is reached and the PSS is active.	Status Input PSSVOLTAGELIMIT
PSS Voltage Unbalanced (Optional)	True when the phase voltage is unbalanced and the PSS is active.	Status Input PSSVOLTAGEUNBALANCED
SCL	True when the Stator Current Limiter is active.	Status Input SCL

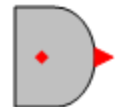




Name	Description	Symbol
Secondary DECS	True when the unit is acting as the secondary DECS. False when the unit is the primary DECS.	Status Input 
Setpoint at Lower Limit	True when the active modes setpoint is at the lower limit.	Status Input 
Setpoint at Upper Limit	True when the active modes setpoint is at the upper limit.	Status Input 
Soft Start Active	True during softstart.	Status Input 
Start Status	True when the unit is in Start mode.	Status Input 
Tracking Comms Loss	True when the DECS-150 is configured as the secondary DECS-150 and has lost tracking communications from the primary DECS-150.	Status Input 
UEL	True when the Under Excitation Limiter is active.	Status Input 
Underfrequency V/Hz	True when the Under Frequency or the Volts/Hz Limiter is active.	Status Input 
Unknown Network Load Share Protocol Version	True when there is another unit on the network whose load share protocol version is not the same as this units load share protocol version.	Status Input 
Var Controller Active	True when the unit is in var mode.	Status Input 
Voltage Matching Active	True when voltage matching is active.	Status Input 
Output Objects		
<i>Physical Outputs</i> OUT1 and OUT2	Physical outputs 1 and 2.	Output - OUTPUT1 
<i>Physical Outputs</i> Breaker Shunt Trip Output	Breaker Shunt Trip physical output. This output is an electronic switch capable of 100 mAdc that can be used to control an external circuit breaker.	Output - BreakerShuntTripOutput 
Off-Page Objects		
Off-Page Output	Used in conjunction with the Off-Page Input to transform an output on one logic page into an input on another logic page. Outputs can be renamed by right-clicking and selecting Rename Output. Right clicking will also show pages that the corresponding inputs can be found on. Selecting the page will take you to that page.	Off-Page Output 

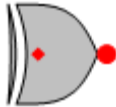

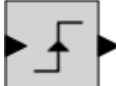
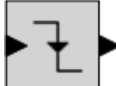
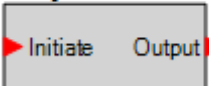
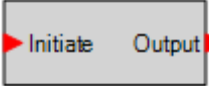
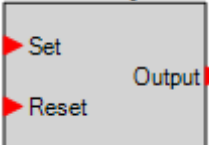
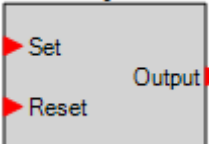
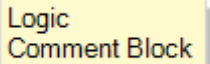
Name	Description	Symbol
Off-Page Input	Used in conjunction with the Off-Page Output to transform an output on one logic page into an input on another logic page. Inputs can be renamed by right-clicking and selecting Rename Input. Right clicking will also show pages that the corresponding outputs can be found on. Selecting the page will take you to that page.	Off-Page Input 
Alarms		
Global Alarm	True when one or more alarms are set.	Alarm 
Configurable Elements 1-8	True when a configurable element alarm is set.	Alarm - CONFIGELEMEN1ALM 
Programmable Alarms 1-16	True when a programmable alarm is set.	Alarm - PROGRAMMABLE_ALARM_1 

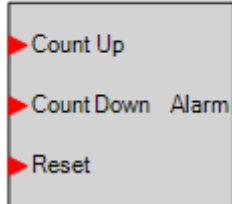
Components

This group contains Logic Gates, Pickup and Dropout Timers, Latches, Comment Blocks, and a counter. Table 19-2 lists the names and descriptions of the objects in the Components group.

Table 19-2. Components Group, Names and Descriptions

Name	Description	Symbol										
Logic Gates												
AND	<table border="1"> <thead> <tr> <th>Input</th> <th>Output</th> </tr> </thead> <tbody> <tr> <td>0 0</td> <td>0</td> </tr> <tr> <td>0 1</td> <td>0</td> </tr> <tr> <td>1 0</td> <td>0</td> </tr> <tr> <td>1 1</td> <td>1</td> </tr> </tbody> </table>	Input	Output	0 0	0	0 1	0	1 0	0	1 1	1	
Input	Output											
0 0	0											
0 1	0											
1 0	0											
1 1	1											
NAND	<table border="1"> <thead> <tr> <th>Input</th> <th>Output</th> </tr> </thead> <tbody> <tr> <td>0 0</td> <td>1</td> </tr> <tr> <td>0 1</td> <td>1</td> </tr> <tr> <td>1 0</td> <td>1</td> </tr> <tr> <td>1 1</td> <td>0</td> </tr> </tbody> </table>	Input	Output	0 0	1	0 1	1	1 0	1	1 1	0	
Input	Output											
0 0	1											
0 1	1											
1 0	1											
1 1	0											
OR	<table border="1"> <thead> <tr> <th>Input</th> <th>Output</th> </tr> </thead> <tbody> <tr> <td>0 0</td> <td>0</td> </tr> <tr> <td>0 1</td> <td>1</td> </tr> <tr> <td>1 0</td> <td>1</td> </tr> <tr> <td>1 1</td> <td>1</td> </tr> </tbody> </table>	Input	Output	0 0	0	0 1	1	1 0	1	1 1	1	
Input	Output											
0 0	0											
0 1	1											
1 0	1											
1 1	1											
NOR	<table border="1"> <thead> <tr> <th>Input</th> <th>Output</th> </tr> </thead> <tbody> <tr> <td>0 0</td> <td>1</td> </tr> <tr> <td>0 1</td> <td>0</td> </tr> <tr> <td>1 0</td> <td>0</td> </tr> <tr> <td>1 1</td> <td>0</td> </tr> </tbody> </table>	Input	Output	0 0	1	0 1	0	1 0	0	1 1	0	
Input	Output											
0 0	1											
0 1	0											
1 0	0											
1 1	0											
XOR	<table border="1"> <thead> <tr> <th>Input</th> <th>Output</th> </tr> </thead> <tbody> <tr> <td>0 0</td> <td>0</td> </tr> <tr> <td>0 1</td> <td>1</td> </tr> <tr> <td>1 0</td> <td>1</td> </tr> <tr> <td>1 1</td> <td>0</td> </tr> </tbody> </table>	Input	Output	0 0	0	0 1	1	1 0	1	1 1	0	
Input	Output											
0 0	0											
0 1	1											
1 0	1											
1 1	0											

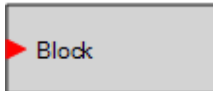
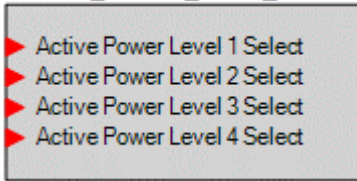
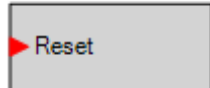

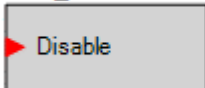
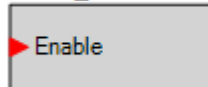
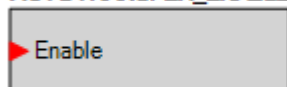
Name	Description	Symbol										
XNOR	<table border="1" data-bbox="656 218 852 373"> <thead> <tr> <th>Input</th> <th>Output</th> </tr> </thead> <tbody> <tr> <td>0 0</td> <td>1</td> </tr> <tr> <td>0 1</td> <td>0</td> </tr> <tr> <td>1 0</td> <td>0</td> </tr> <tr> <td>1 1</td> <td>1</td> </tr> </tbody> </table>	Input	Output	0 0	1	0 1	0	1 0	0	1 1	1	
Input	Output											
0 0	1											
0 1	0											
1 0	0											
1 1	1											
NOT (INVERTER)	<table border="1" data-bbox="651 394 857 487"> <thead> <tr> <th>Input</th> <th>Output</th> </tr> </thead> <tbody> <tr> <td>0</td> <td>1</td> </tr> <tr> <td>1</td> <td>0</td> </tr> </tbody> </table>	Input	Output	0	1	1	0					
Input	Output											
0	1											
1	0											
Rising Edge	The output is true when the rising edge of a pulse is detected on the input signal.											
Falling Edge	The output is true when the falling edge of a pulse is detected on the input signal.											
Pickup and Dropout Timers												
Drop Out Timer	Used to set a delay in the logic. For more information, refer to <i>Programming BESTlogicPlus, Pickup and Dropout Timers</i> , later in this section.	<p data-bbox="1175 751 1365 831">Drop Out Timer (1) TIMER_1 Delay = 1</p> 										
Pick Up Timer	Used to set a delay in the logic. For more information, refer to <i>Programming BESTlogicPlus, Pickup and Dropout Timers</i> , later in this section.	<p data-bbox="1175 947 1349 1026">Pick Up Timer (1) TIMER_1 Delay = 1</p> 										
Latches												
Reset Priority Latch	When the Set input is on and the Reset input is off, the latch will go to the Set (On) state. When the Reset input is on and the Set input is off, the latch will go to the Reset (Off) state. If both the Set and Reset inputs are on at the same time, a reset priority latch will go to the Reset (Off) state.	<p data-bbox="1175 1178 1373 1203">Reset Priority Latch</p> 										
Set Priority Latch	When the Set input is on and the Reset input is off, the latch will go to the Set (On) state. When the Reset input is on and the Set input is off, the latch will go to the Reset (Off) state. If both the Set and Reset inputs are on at the same time, a set priority latch will go to the Set (On) state.	<p data-bbox="1175 1377 1349 1402">Set Priority Latch</p> 										
Other												
Comment Block	Enter user comments.											


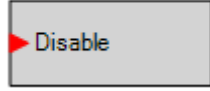

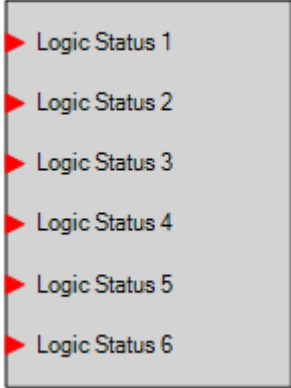
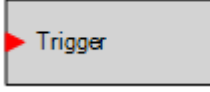
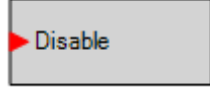
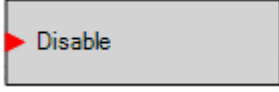

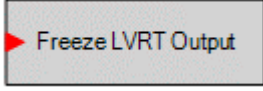
Name	Description	Symbol
Counter	<p>True when the count reaches a user-selected number. The Count Up input increments the count when a true is received. The Count Down input decrements the count when a true is received. The Reset input resets the count to zero when a true is received. The Alarm output is true when the count reaches the trigger count. The trigger count is set by the user and is found in Settings Explorer, BESTlogicPlus Programmable Logic, Logic Counters.</p>	<p>Counter (1) Counter 1 Trigger Count = 1</p> 


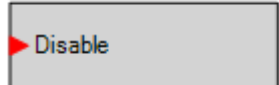
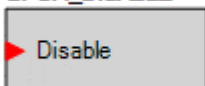
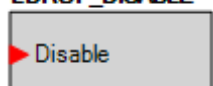
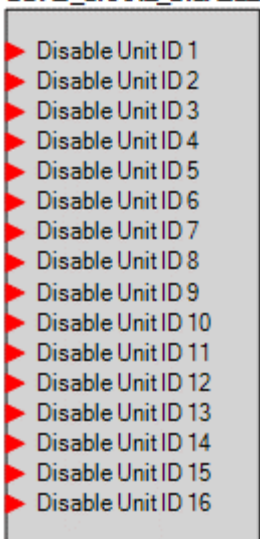
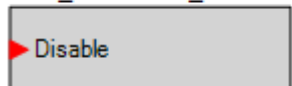
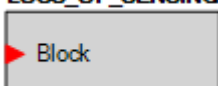
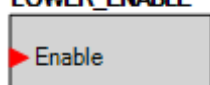
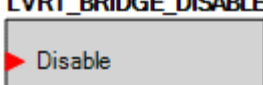
Elements

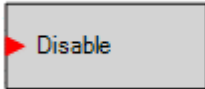
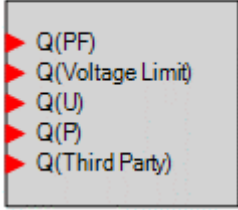
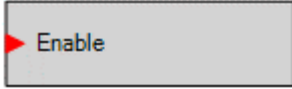


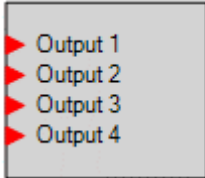

Table 19-3 lists the names and descriptions of the elements in the Elements group.

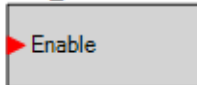


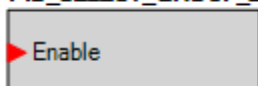
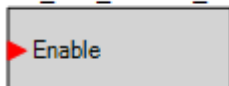
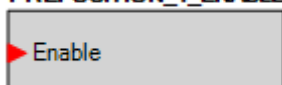
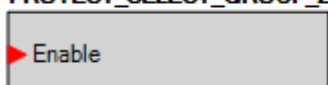
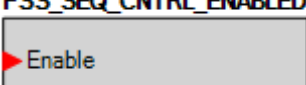
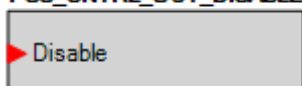
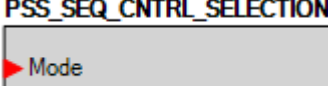
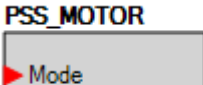
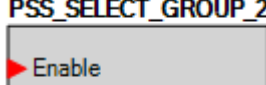
Table 19-3. Elements Group, Names and Descriptions

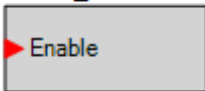
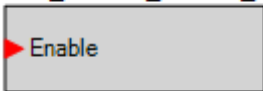

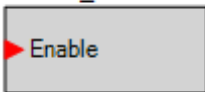
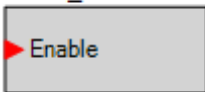
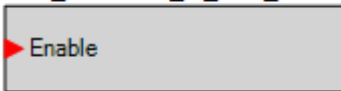
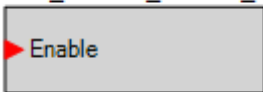
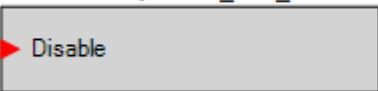
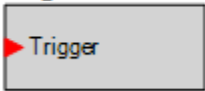

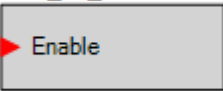
Name	Description	Symbol
27	<p>When true, this element blocks, or disables, the 27 undervoltage protection function.</p>	<p>27</p> 
Active Power Level Select	<p>This element allows selection of the active power level. When an input is true, the corresponding active power level is selected. When no inputs are true, the active power level is 0.0. When multiple inputs are true, the highest active power level is selected. For example, if inputs 2 and 3 are true, active power level 3 is selected.</p>	<p>ACTIVE_POWER_LEVEL_SELECT</p> 
Alarm Reset	<p>When true, this element resets all active alarms.</p>	<p>ALARM_RESET</p> 
APC Bridge Disable	<p>When true, this element disables APC Bridge mode.</p>	<p>APC_BRIDGE_DISABLE</p> 
APC Disable	<p>When true, this element disables Grid Code APC mode.</p>	<p>APC_DISABLE</p> 
Auto Enable	<p>When true, this element sets the unit in Auto mode (AVR).</p>	<p>AUTO_ENABLE</p> 
Auto Transfer Enable	<p>When true, this element sets the unit as secondary. When false, the unit is primary.</p>	<p>AUTOTRANSFER_ENABLE</p> 

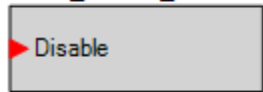

Name	Description	Symbol
Configurable Element 1-8	Configurable elements are connected to the logic scheme as outputs. These elements are configurable in BESTCOMS <i>Plus</i> under Programmable Outputs, Configurable Elements. The user can assign a string of up to 16 characters and configure whether the element should generate an alarm or provide status only. If used for alarm, the user's text is what will appear in the event log.	CONFELMNT1 Config Element 1 
Cross Current Compensation Disable	When true, this element disables cross current compensation.	CC_DISABLE 
Custom LED	When true, this element sets the Custom Alarm on the front panel.	CUSTOM_LED 
Datalog Logic Status 1-6	When true, Logic Status x can be selected and displayed in the data log and real-time monitor.	DATALOG_LOGIC_STATUS 
Datalog Trigger	When true, this element triggers the datalog to begin recording data.	DATALOGTRIGGER 
Droop Disable	When true, this element disables droop when the unit is operating in AVR mode.	DROOP_DISABLE 
External Tracking Disable	When true, this element disables external tracking.	EXT_TRACKING_DISABLE 
Freeze APC Output	When true, the output of the APC PI controller is frozen. This can be used with the APC REMOTE COMM FAIL status input to freeze APC output when remote communication fails.	FREEZE_APC_OUTPUT 
Freeze LVRT Output	When true, the output of the LVRT controller is frozen. This can be used with the LVRT REMOTE COMM FAIL status input to freeze LVRT output when remote communication fails.	FREEZE_LVRT_OUTPUT 

Name	Description	Symbol
Grid Code Disable	When true, overall Grid Code functionality is disabled.	GRIDCODE_DISABLE 
Internal Tracking Disable	When true, this element disables internal tracking.	INT_TRACKING_DISABLE 
LFSM Disable	When true, Grid Code LFSM is disabled	LFSM_DISABLE 
Line Drop Disable	When true, this element disables line drop when the unit is operating in AVR mode.	LDROP_DISABLE 
Load Share Disable	This element allows load sharing with specific units on the network to be disabled. When an input to this block is true, load share data received from that unit is ignored by the DECS-150.	LOAD_SHARE_DISABLE 
Loss of Sensing Transfer Disable	When true, this element disables the transfer to Manual mode during a Loss of Sensing condition.	LOS_TRANSFER_DISABLE 
Loss of Sensing	When true, this element disables the Loss of Sensing function.	LOSS_OF_SENSING 
Lower Enable	When true, this element lowers the active setpoint.	LOWER_ENABLE 
LVRT Bridge Disable	When true, LVRT Bridge mode is disabled.	LVRT_BRIDGE_DISABLE 

Name	Description	Symbol
LVRT Disable	When true, LVRT mode is disabled.	LVRT_DISABLE 
LVRT Mode Select	<p>When an input is true, the corresponding LVRT control mode is active.</p> <p>When no inputs are true, the default operating mode is Power Factor.</p> <p>When multiple inputs are true, the active control mode is selected in the following priority order: Q(PF) > Q(Voltage Limit) > Q(U) > Q(P) > Q(Third Party). For example, if inputs Q(Voltage Limit) and Q(P) are true, Q(Voltage Limit) becomes the active control mode. See the <i>Grid Code</i> section for details.</p>	LVRT_MODE_SELECT 
LVRT Remote Fail Mode	<p>This element can be used to toggle the operating mode (Q(PF) or Hold Value) when an LVRT Remote Communications Failure has occurred. When an LVRT Remote Communications Failure has been detected, the LVRT Mode during the failure will be controlled by the Fail Mode Setting and this logic element. When the LVRT Remote Control Fail Mode is set to Q(PF), the operating mode will be Q(PF) and this logic element has no effect. When the LVRT Remote Control Fail Mode is set to Hold Value, this logic element can be used to set the operating mode during an LVRT Remote Communications Failure as indicated below:</p> <ul style="list-style-type: none"> • When true the LVRT Remote Control Failure Mode is set to Hold Output. • When False the LVRT Remote Control Failure Mode is set to Q(PF). 	REMOTE_LVRT_FAILMODE 
Manual Enable	When true, this element switches the unit to Manual mode.	MANUAL_ENABLE 
Network Load Share Disable	When true, this element disables network load sharing.	NETWORK_LOAD_SHARE_DISABLE 
NLS Broadcast	This element functions in conjunction with the Network Load Share Status input on all units on the network. When an input is true, the corresponding Network Load Share Status input on all units on the network is true.	NLS_BROADCAST 
OEL Disabled in Manual Mode	When true, this element disables OEL when the unit is operating in Manual mode.	OEL_DISABLED_IN_MAN_MODE 

Name	Description	Symbol
OEL Online	When true, this element enables the use of OEL when the unit is considered online.	OEL_ONLINE 
OEL Select Secondary Settings	When true, this element selects the secondary settings for OEL.	OEL_SELECT_GROUP_2 
Parallel Enable LM	When true, this element informs the unit that it is online. The element should be enabled when the 52LM is closed. This element also allows UEL and droop compensation to operate when true.	PARALLEL_ENABLE_LM 
PID Select Secondary Settings	When true, this element selects secondary settings on the PID.	PID_SELECT_GROUP_2 
PF/var Enable	When true, this element enables the PF and Var controller. The Var/PF Selection element must be set to true to use var or PF mode.	PF_VAR_ENABLE_JK 
Pre-Position 1-3 Enable	When true, this element informs the unit to use setpoints for Pre-Position x.	PREPOSITION_1_ENABLE 
Protection Select Secondary Settings	When true, this element informs the unit to use secondary values for protection.	PROTECT_SELECT_GROUP_2 
PSS Sequence Control Enabled	When true, PSS sequence (phase rotation) control is enabled. (Available when the controller is equipped with the optional Power System Stabilizer, style number xPxxx.)	PSS_SEQ_CNTRL_ENABLED 
PSS Output Disable	When true, this element disables the output of the PSS. The PSS continues to run, but the output is not used. (Available when the controller is equipped with the optional Power System Stabilizer, style number xPxxx.)	PSS_CNTRL_OUT_DISABLE 
PSS Sequence Control Selection	When true, phase rotation is selected to be ACB. False when phase rotation is selected to be ABC. (Available when the controller is equipped with the optional Power System Stabilizer, style number xPxxx.)	PSS_SEQ_CNTRL_SELECTION 
PSS Motor	When true, the PSS is in motor mode. False when in generator mode. (Available when the controller is equipped with the optional Power System Stabilizer, style number xPxxx)	PSS_MOTOR 
PSS Select Secondary Settings	When true, this element selects secondary settings for the PSS. (Available when the controller is equipped with the optional Power System Stabilizer, style number xPxxx.)	PSS_SELECT_GROUP_2 

Name	Description	Symbol
Raise Enable	When true, this element raises the active setpoint.	RAISE_ENABLE 
SCL Select Secondary Settings	When true, this element selects the secondary settings for SCL.	SCL_SELECT_GROUP_2 
Soft Start Select Secondary Settings	When true, this element selects the secondary settings for softstart.	SOFT_START_SELECT_GROUP_2 
Start Enable	When true, this element starts the unit.	START_ENABLE 
Stop Enable	When true, this element stops the unit.	STOP_ENABLE 
UEL Disabled in Manual Mode	When true, this element disables UEL when the unit is operating in Manual mode.	UEL_DISABLED_IN_MAN_MODE 
UEL Select Secondary Settings	When true, this element selects secondary settings for UEL.	UEL_SELECT_GROUP_2 
Underfrequency V/Hz Disable	When true, this element disables the V/Hz Underfrequency limiter.	UNDERFREQUENCY_VHZ_DISABLE 
User Programmable Alarm 1-16	When true, this element triggers a programmable alarm.	USERALM1 Programmable Alarm 1 Name 
Var/PF Mode	The var input selects var control and the PF input selects power factor control.	VAR_PF_MODE 
Var/PF Selection Enable	When true, this element allows the selection of var and PF.	VAR_PF_SELECTION 

Name	Description	Symbol
Voltage Matching Disable	When true, this element disables voltage matching when the unit is operating in AVR mode.	VOLT_MATCH_DISABLE 
Watchdog Output	When true, this element opens the normally-open watchdog output and closes the normally-closed watchdog output.	WATCHDOG_OUTPUT 

Logic Schemes

A logic scheme is a group of logic variables written in equation form that defines the operation of a DECS-150 Digital Excitation System. Each logic scheme is given a unique name. This gives you the ability to select a specific scheme and be confident that the selected scheme is in operation. One logic scheme is configured for a typical protection and control application of a synchronous machine and is the default active logic scheme. Only one logic scheme can be active at a given time. In most applications, preprogrammed logic schemes eliminate the need for custom programming. Preprogrammed logic schemes may provide more inputs, outputs, or features than are needed for a particular application. This is because a preprogrammed scheme is designed for a large number of applications with no special programming required. Unneeded logic block outputs may be left open to disable a function or a function block can be disabled through operating settings.

When a custom logic scheme is required, programming time is reduced by modifying the default logic scheme.

The Active Logic Scheme

The DECS-150 must have an active logic scheme in order to function. All DECS-150 controllers are delivered with a default, active logic scheme preloaded in memory. The logic scheme is tailored for a system with the PSS option disabled or enabled depending on the PSS option selected in the system style number. The functionality of this logic scheme is similar to the functionality of a DECS-100. If the function block configuration and output logic of the default logic scheme meet the requirements of your application, then only the operating settings (system parameters and threshold settings) need to be adjusted before placing the DECS-150 in service.

Sending and Retrieving Logic Schemes

Retrieve a Logic Scheme from the DECS-150

To retrieve settings from the DECS-150, the DECS-150 must be connected to a computer through a communications port. Once the necessary connections are made, settings can be downloaded from the DECS-150 by selecting Download Settings and Logic on the Communication pull-down menu.

Send a Logic Scheme to the DECS-150

To send settings to the DECS-150, the DECS-150 must be connected to a computer through a communications port. Once the necessary connections are made, settings can be uploaded to the DECS-150 by selecting Upload Settings and Logic on the Communication pull-down menu.

Caution

Always remove the DECS-150 from service prior to changing or modifying the active logic scheme. Attempting to modify a logic scheme while the DECS-150 is in service could generate unexpected or unwanted outputs.

Modifying a logic scheme in BESTCOMSP^{Plus} does not automatically make that scheme active in the DECS-150. The modified scheme must be uploaded into the DECS-150. See the paragraphs on *Sending and Retrieving Logic Schemes* above.

Default Logic Schemes

The default logic scheme for PSS-disabled systems is shown in Figure 19-2 and the default logic scheme for PSS-enabled systems is shown in Figure 19-3.

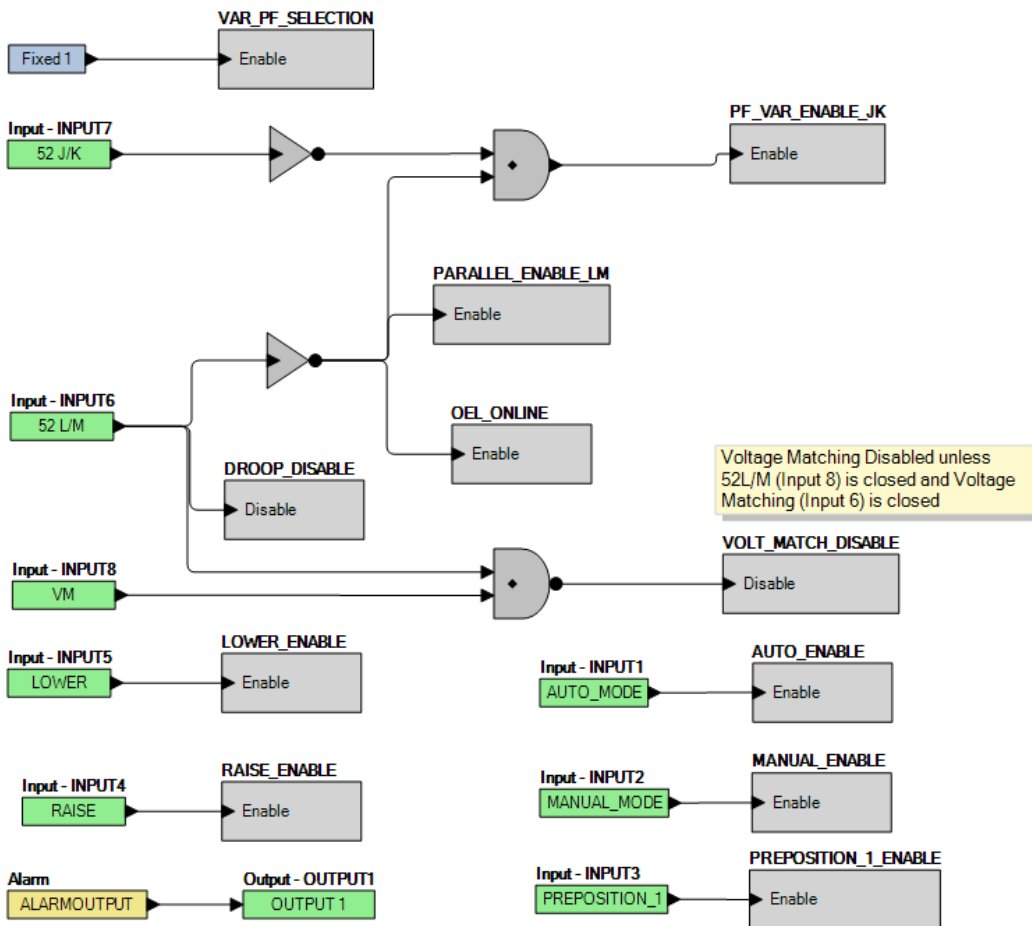


Figure 19-2. PSS-Disabled Default Logic

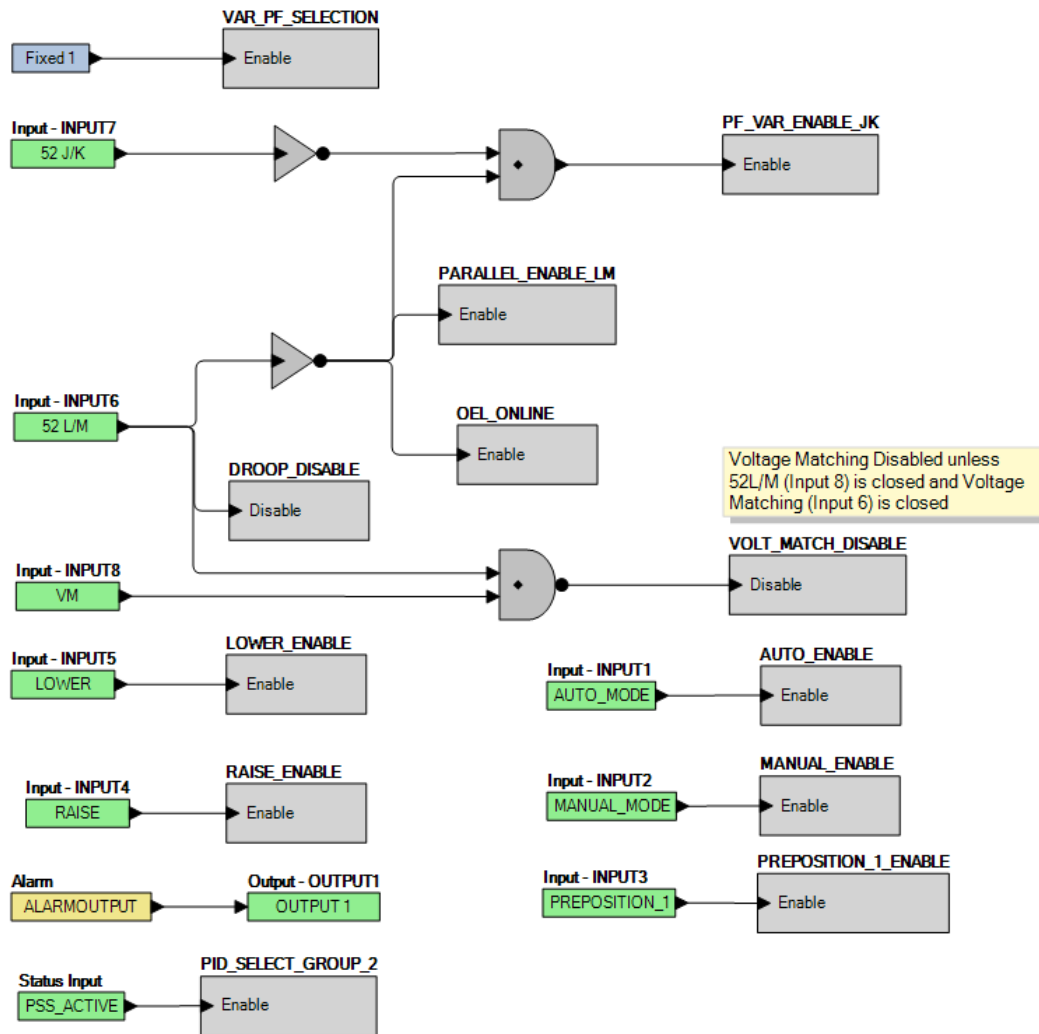


Figure 19-3. PSS-Enabled Default Logic

Programming BESTlogic™ Plus

Use BESTCOMSPlus® to program BESTlogicPlus. Using BESTlogicPlus is analogous to physically attaching wire between discrete DECS-150 terminals. To program BESTlogicPlus, use the Settings Explorer within BESTCOMSPlus to open the BESTlogicPlus Programmable Logic tree branch as shown in Figure 19-1.

The drag and drop method is used to connect a variable or series of variables to the logic inputs, outputs, components, and elements. To draw a wire/link from port to port (triangles), click the left mouse button on a port, pull the wire onto another port, and release the left mouse button. A red port indicates that a connection to the port is required or missing. A black port indicates that a connection to the port is not required. Drawing wires/links from input to input or output to output is not allowed. Only one wire/link can be connected to any one output. If the proximity of the endpoint of the wire/link is not exact, it may attach to an unintended port.

If an object or element is disabled, it will have a yellow X on it. To enable the element, navigate to the settings page for that element. A red X indicates that an object or element is not available per the style number of the DECS-150.

The view of the Main Logic and Physical Outputs can be automatically arranged by clicking the right mouse button on the window and selecting Auto-Layout.

The following conditions must be met before *BESTCOMSPi* will allow logic to be uploaded to the DECS-150:

- A minimum of two inputs and a maximum of 32 inputs on any multi-port (AND, OR, NAND, NOR, XOR, and XNOR) gate.
- A maximum of 24 logic levels for any particular path. A path being an input block or an output side of an element block through gates to an output block or an input side of an element block. This is to include any OR gates on the Physical Outputs page, but not the matched pairs of Physical Outputs blocks.
- A maximum of 256 gates per logic level with a maximum of 125 gates allowed per diagram. All output blocks and input sides of element blocks are at the maximum logic level of the diagram. All gates are pushed forward/upwards in logic levels and buffered to reach the final output block or element block if needed.

Three status indicators are located in the lower right corner of the *BESTlogicPi* window. These indicators show the Logic Save Status, Logic Diagram Status, and Logic Layer Status. Table 19-4 defines the colors for each indicator.

Table 19-4. Status Indicators

Indicator	Color	Definition
Logic Save Status (Left Indicator)	● Orange	Logic has changed since last save.
	● Green	Logic has NOT changed since last save.
Logic Diagram Status (Center Indicator)	● Red	Requirements NOT met as listed above.
	● Green	Requirements met as listed above.
Logic Layer Status (Right Indicator)	● Red	Requirements NOT met as listed above.
	● Green	Requirements met as listed above.

Pickup and Dropout Timers

A pickup timer produces a true output when the elapsed time is greater than or equal to the Pickup Time setting after a false to true transition occurs on the Initiate input from the connected logic. Whenever the Initiate input status transitions to false, the output transitions to false immediately.

A drop out timer produces a true output when the elapsed time is greater than or equal to the Dropout Time setting after a true to false transition occurs on the Initiate input from the connected logic. Whenever the Initiate input transitions to true, the output transitions to false immediately. Refer to Figure 19-4.

To program logic timer settings, use the Settings Explorer within *BESTCOMSPi*® to open the *BESTlogicPi* Programmable Logic/Logic Timers tree branch. Enter a Name label that you want to appear on the timer logic block. The Time Delay value range is 0 to 250 hours in 1 hour increments, 0 to 250 minutes in 1 minute increments, or 0 to 1,800 seconds in 0.1 second increments.

Next, open the Components tab inside the *BESTlogicPi* window and drag a timer onto the program grid. Right click on the timer to select the timer you want to use that was previously set on the Logic Timers tree branch. The Logic Timer Properties Dialog Box will appear. Select the timer you want to use.

Timing accuracy is ±15 milliseconds.

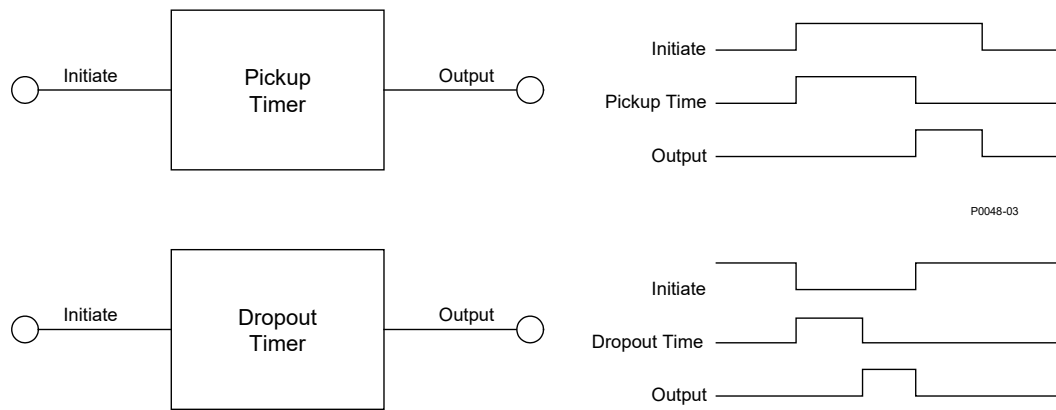


Figure 19-4. Pickup and Dropout Timer Logic Blocks

Offline Logic Simulator

You can use the offline logic simulator to test your custom logic before placing it in operation. The state of various logic elements can be toggled to verify that the logic states travel through the system as expected.

Before running the logic simulator, you must click the Save button on the BESTlogicPlus toolbar to save the logic to memory. Changes to the logic (other than changing the state) are disabled when the simulator is enabled. Colors are selected by clicking the Options button on the BESTlogicPlus toolbar. By default, Logic 0 is red and Logic 1 is green. Using your mouse, double-click on a logic element to change its state.

An example of the offline logic simulator is shown in Figure 19-5. STOP_ENABLE is Logic 0 (red) when Input 1 is Logic 1 (green), Input 2 is Logic 0 (red), and the inverter is Logic 1 (green).

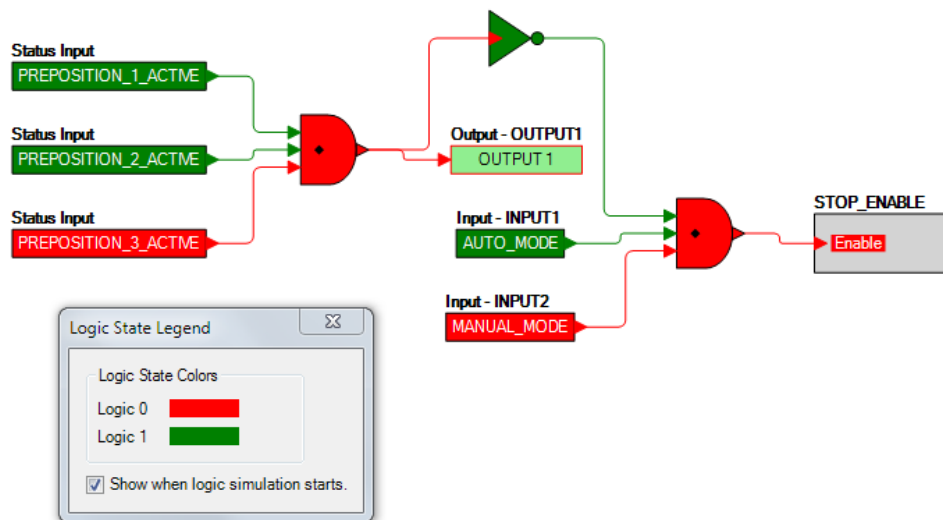


Figure 19-5. Offline Logic Simulator Example

BESTlogic™ Plus File Management

To manage BESTlogicPlus files, use the Settings Explorer to open the BESTlogicPlus Programmable Logic tree branch. Use the BESTlogicPlus Programmable Logic toolbar to manage BESTlogicPlus files. Refer to Figure 19-6. For information on Settings Files management, refer to the *BESTCOMSPPlus Software* section.



Figure 19-6. BESTlogicPlus Programmable Logic Toolbar

Saving a BESTlogicPlus File

After programming BESTlogicPlus settings, click on the *Save* button to save the settings to memory.

Before the new BESTlogicPlus settings can be uploaded to the DECS-150, you must select *Save* from the *File* pull-down menu located at the top of the BESTCOMSPPlus main shell. This step will save both the BESTlogicPlus settings and the operating settings to a file.

The user also has the option to save the BESTlogicPlus settings to a unique file that contains only BESTlogicPlus settings. Click on the *Logic Library* drop-down button and select *Save Logic Library File*. Use normal Windows® techniques to browse to the folder where you want to save the file and enter a filename to save as.

Opening a BESTlogicPlus File

To open a saved BESTlogicPlus file, click on the *Logic Library* drop-down button on the BESTlogicPlus Programmable Logic toolbar and select *Open Logic Library File*. Use normal Windows techniques to browse to the folder where the file is located.

Protecting a BESTlogicPlus File

Objects in a logic diagram can be locked so that when the logic document is protected these objects cannot be changed. Locking and protecting is useful when sending logic files to other personnel to be modified. The locked object(s) cannot be changed. To view the lock status of the object(s), select *Show Lock Status* from the *Protection* drop-down menu. To lock object(s), use the mouse to select object(s) to be locked. Right click on the selected object(s) and select *Lock Object(s)*. The gold colored padlock next to the object(s) will change from an open to a locked state. To protect a logic document, select *Protect Logic Document* from the *Protection* drop-down button. Establishing a password is optional.

Uploading a BESTlogicPlus File

To upload a BESTlogicPlus file to the DECS-150, you must first open the file through BESTCOMSPPlus® or create the file using BESTCOMSPPlus. Then pull down the *Communication* menu and select *Upload Logic*.

Downloading a BESTlogicPlus File

To download a BESTlogicPlus file from the DECS-150, you must pull down the *Communication* menu and select *Download Settings and Logic from Device*. If the logic in your BESTCOMSPPlus has changed, a dialog box will open asking you if you want to save the current logic changes. You may choose *Yes* or *No*. After you have taken the required action to save or not save the current logic, the downloading is executed.

Copying and Renaming Preprogrammed Logic Schemes

Copying a saved logic scheme and assigning a unique name is accomplished by first loading the saved logic scheme into BESTCOMSPPlus. Click on the *Logic Library* drop-down button and select *Save Logic Library File*. Use normal Windows® techniques to browse to the folder where you want to save the new file and enter a filename to save as. Changes are not activated until the new settings have been saved and uploaded to the device.

Printing a BESTlogicPlus File

To view a preview of the printout, click on the *Print* icon located on the BESTlogicPlus Programmable Logic toolbar. If you wish to print to a printer, select the printer icon in the upper left corner of the *Print Preview* screen.

Clearing the On-Screen Logic Diagram

Click on the Clear button to clear the on-screen logic diagram and start over.

BESTlogic™ Plus Examples

Example 1 - PREPOSITION_1_ENABLE Logic Block Connections

Figure 19-7 illustrates the PREPOSITION_1_ENABLE logic block and one input logic block. Pre-Position 1 is enabled when Input 1 is active.

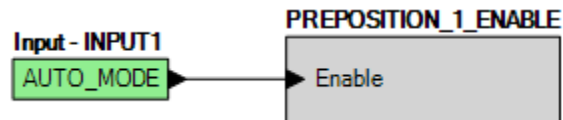


Figure 19-7. Example 1 - PREPOSITION_1_ENABLE Logic Block Connections

Example 2 - AND Gate Connections

Figure 19-8 illustrates a typical AND gate connection. In this example, Output 2 will become active when Inputs 7 and 8 are true.

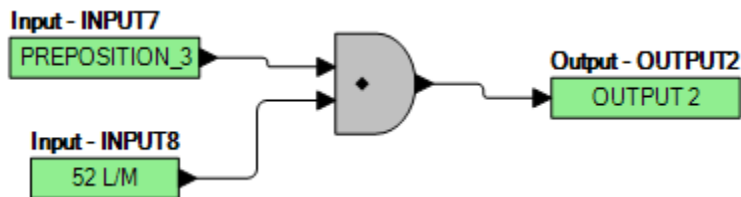


Figure 19-8. Example 2 - AND Gate Connections



20 • Communication

USB Communication

A type B, USB port connects the DECS-150 with a PC operating BESTCOMSPi.us® for local, short-term communication. This mode of communication is useful for settings configuration and system commissioning. The USB port is located on the front or rear panel depending on style chosen, and illustrated in the *Front Panel* section of this manual. A USB device driver for the DECS-150 is automatically installed on your PC during the installation of BESTCOMSPi.us. Information about establishing communication between BESTCOMSPi.us and the DECS-150 is provided in the *BESTCOMSPi.us Software* section of this manual.

Caution

In accordance with the guidelines defined in USB standards, the USB port on this device is not isolated. To prevent damage to a connected PC or laptop, the DECS-150 must be properly tied to ground.

Powering the DECS-150 through the USB Port

The DECS-150 can be partially powered from the USB port when no input power is applied. The following capabilities are functional in this mode:

- The settings interface will operate as expected.
- Settings and all reports can be downloaded from the unit.
- Settings and firmware can be uploaded to the unit.

The following capabilities will not function in this mode:

- Voltage regulation
- Ethernet communication
- Metering (including the alarm panel)

If the unit is partially powered by USB followed by application of input power, the USB connection may have to be re-established by removing and re-inserting the USB connector. Likewise, if a USB connection is established while input power is applied and input power is lost, the USB connection may have to be re-established by removing and re-inserting the USB connector.

Communication with a Second DECS-150

The CAN (controller area network) interface (CAN 2) port facilitates communication between two DECS-150s and enables regulation setpoint tracking to occur in a dual, or redundant, DECS-150 application. External setpoint tracking is possible between two DECS-150s.

Connections

DECS-150 CAN connections should be made with twisted-pair, shielded cable. The CAN port (designated CAN 2) has a CAN high (C2H) terminal, a CAN low (C2L) terminal, and a CAN drain (GND) terminal. CAN port terminals are illustrated in the *Terminals and Connectors* section of this manual.

Modbus® Communication

BESTCOMSPi.us Navigation Path: [Settings Explorer](#), [Communications](#), [Modbus Setup](#)

DECS-150 systems support the Modbus TCP protocol (Ethernet). DECS-150 Modbus communication registers are listed and defined in the *Modbus Communication* section of this manual.

Modbus settings for Ethernet are illustrated in Figure 20-1.

When Auto Save Settings is enabled, settings are automatically saved to nonvolatile memory after Modbus writes. Alternately, when Auto Save is disabled, you must write to the Save All Settings Modbus register to save settings.

The screenshot shows a configuration window titled "Modbus Setup". It contains two sections: "Ethernet Settings" and "Auto Save Settings". In the "Ethernet Settings" section, there is a field for "Unit ID" with the value "1" entered. In the "Auto Save Settings" section, there is a checkbox labeled "Enabled" which is checked.

Figure 20-1. Modbus Setup

Ethernet Communication

Located on the rear panel, the Ethernet port provides communication with a PC running BESTCOMSPi^{us} and uses the Modbus TCP protocol for polled communication with other networked devices. This 10BASE-T/100BASE-TX port is an eight-pin RJ45 connector that connects to shielded, twisted-pair, Category 5 copper wire media.

Ethernet Setup

Initially you must use a USB connection on the front panel to configure communications.

1. Connect an Ethernet cable between the DECS-150 and your network.
2. Connect a USB cable between the DECS-150 and your PC.
3. Use BESTCOMSPi^{us} to connect to the DECS-150 through the USB port.
4. Select Configure, Ethernet from the Communication pull-down menu. If the DECS-150 is connected properly, the Configure Ethernet Port screen shown in Figure 20-2 will appear.

The screenshot shows a dialog box titled "Configure Ethernet Port". At the top, there are three buttons: "Download", "Send to Device", and "Close". Below these are three sections for IP configuration: "IP Address" with four input boxes containing "0", "0", "0", "0"; "Default Gateway" with four input boxes containing "0", "0", "0", "1"; and "Subnet Mask" with four input boxes containing "255", "0", "0", "0". At the bottom, there is a checkbox labeled "Use DHCP" which is checked.

Figure 20-2. Configure Ethernet Port

DHCP (Dynamic Host Configuration Protocol) is enabled by default and allows the DECS-150 to send a broadcast request for configuration information. The DHCP server receives the request and responds with configuration information. Use the Device Discovery function on the DECS-150 Connection screen in BESTCOMSPi^{us} to locate the Active IP address of the DECS-150.

If DHCP is not being used, use BESTCOMSPi^{us} to configure the Ethernet port as described in the following paragraphs.

Configurable Ethernet options include:

<i>IP Address:</i>	Internet Protocol Address to be used by the DECS-150.
<i>Default Gateway:</i>	Default host to send data destined for a host not on the network subnet.
<i>Subnet Mask:</i>	Mask used to determine the range of the current network subnet.
<i>Use DHCP:</i>	When this box is checked, the IP Address, Default Gateway, and Subnet Mask are automatically configured via DHCP. This can be used only if the Ethernet network has a properly configured DHCP server running. The DECS-150 does not act as a DHCP server.

5. Obtain the values for these options from the site administrator if the DECS-150 is intended to share the network with other devices.
6. If the DECS-150 is operating on an isolated network, the IP address can be chosen from one of the following ranges as listed in IETF publication RFC 1918, *Address Allocation for Private Networks*.
 - 10.0.0.0 - 10.255.255.255
 - 172.16.0.0 - 172.31.255.255
 - 192.168.0.0 - 192.168.255.255

If the DECS-150 is operating on an isolated network, the Subnet Mask can be left at 0.0.0.0 and the Default Gateway can be chosen as any valid IP address from the same range as the DECS-150 IP address.

Note

The PC running BESTCOMSP*lus* software must be configured correctly to communicate with the DECS-150. The PC must have an IP address in the same subnet range as the DECS-150 if the DECS-150 is operating on a private, local network.

Otherwise, the PC must have a valid IP address with access to the network and the DECS-150 must be connected to a properly configured router. The network settings of the PC depend on the operating system installed. Refer to the operating system manual for instructions.

On most Microsoft Windows based PCs, the network settings can be accessed through the Network Connections icon located inside the Control Panel.

7. Click the Send to Device button located on the Configure Ethernet Port screen. The DECS-150 is now ready to be used on a network.
8. If desired, DECS-150 settings can be verified by selecting Download Settings and Logic from Device from the Communication pull-down menu. Active settings will be downloaded from the DECS-150. Verify that the downloaded settings match the previously sent settings.

Ethernet Connection

1. Connect the DECS-150 to the PC using a standard Ethernet cable.
2. Apply operating power to the DECS-150.
3. In BESTCOMSP*lus*[®], click Communication, New Connection, DECS-150, or click the Connection button on the lower menu bar. The DECS-150 Connection window appears as shown in Figure 20-3.

4. If you know the IP address of the DECS-150, click the radio button for the Ethernet Connection IP at the top of the DECS-150 Connection window, enter the address into the fields and click the Connect button.
5. If you don't know the IP address, you can perform a scan to search for all connected devices by clicking the Ethernet button in the Device Discovery box. After the scan is complete, a window containing the connected devices will be displayed. See Figure 20-4.
6. At this point you can also add any or all of the detected devices to the Device Directory. This prevents the need to scan for connected devices each time a connection is desired. Simply select a device from the list and click Add. Clicking Add All will add all detected devices from the list to the Device Directory. The Device Directory stores the name, model, and address of devices you have added. Click the radio button for Select Device to Connect to, select the device from the Device Directory list, and click the Connect button at the top of the DECS-150 Connection window.
7. Choose the desired device from the list and click Connect. Wait for connection to complete.
8. The Advanced button displays the following window. It contains options for enabling Auto Reconnect, downloading settings after reconnect, the delay between retries (in milliseconds), and the maximum number of attempts. See Figure 20-5.

DECS-150 Connection

Ethernet Connection [IP (Address : Port)]

10 0 11 141 : 2102

USB Connection

Select Device to Connect to

Device Directory

Description	Model	Serial Number	IP Address	COM Port	Phone Number	Default Connect
-------------	-------	---------------	------------	----------	--------------	-----------------

Delete Edit Add Advanced... Close

Device Discovery

Scan For Connected Devices

Ethernet

USB

Connect

Figure 20-3. DECS-150 Connection Window

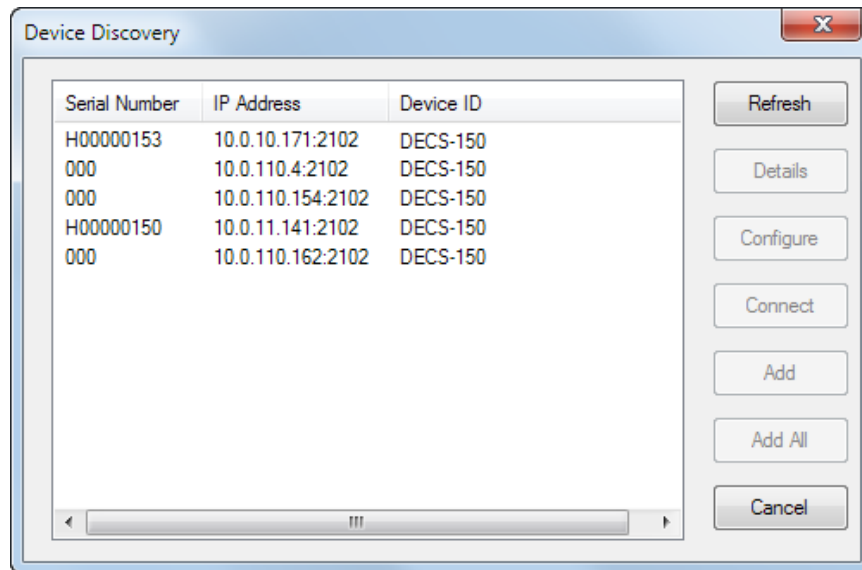


Figure 20-4. Device Discovery Window

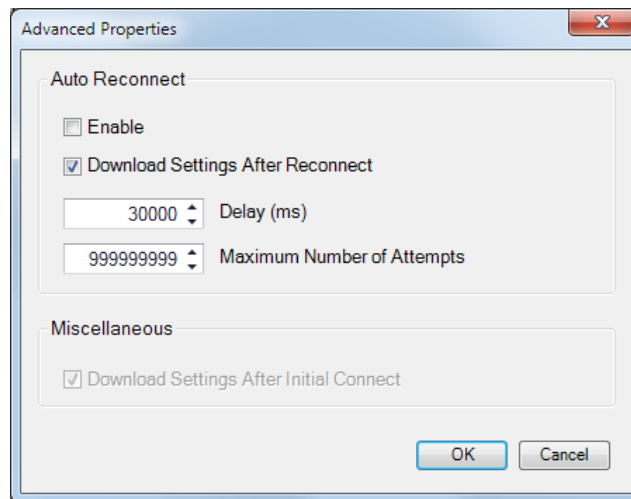


Figure 20-5. Advanced Properties, Auto Reconnect

Note

The PC running BESTCOMSP*lus* software must be configured correctly to communicate with the DECS-150. The PC must have an IP address in the same subnet range as the DECS-150 if the DECS-150 is operating on a private, local network.

Otherwise, the PC must have a valid IP address with access to the network and the DECS-150 must be connected to a properly configured router. The network settings of the PC depend on the operating system installed. Refer to the operating system manual for instructions.

On most Microsoft® Windows® based PCs, the network settings can be accessed through the Network Connections icon located inside the Control Panel.



21 • Configuration

Before the DECS-150 is placed in service, it must be configured for the controlled equipment and application.

Operating Mode

BESTCOMSPlus Navigation Path: Settings Explorer, Operating Settings, Operating Mode

Operating mode can be set to generator or motor. Power factor and var metering values will be opposite in motor mode. Operating mode settings are illustrated in Figure 21-1.

Raise/Lower Configuration

In motor mode, the Raise/Lower Configuration must also be configured.

When set to Adjust Excitation, the Raise input raises the regulator output, var/pf decreases. The Lower input lowers the regulator output, var/pf increases.

When set to Adjust Setpoint, the Raise input raises the excitation setpoint, var/pf increases. The Lower input lowers the excitation setpoint, var/pf decreases.

The screenshot shows a configuration window titled "Operating Mode". Inside the window, there are two dropdown menus. The first is labeled "Operating Mode" and has "Motor mode" selected. The second is labeled "Raise/Lower Configuration" and has "Adjust Excitation" selected.

Figure 21-1. Operating Mode Screen

Machine, Field, and Bus Ratings

BESTCOMSPlus Navigation Path: Settings Explorer, System Parameters, Rated Data

Machine and field rating settings are illustrated in Figure 21-2.

For proper excitation control and protection, the DECS-150 must be configured with the ratings of the controlled machine and field. These ratings are typically shown on the machine nameplate or can be obtained from the machine manufacturer. Required machine ratings include the voltage, frequency, power factor, and apparent power (kVA). Machine current and real power (kW) are listed with the other machine ratings as read-only settings. These values are automatically calculated from the other machine ratings entered by the user. Required field ratings include the no-load dc voltage and current and full-load voltage and current.

In applications where the generator will be paralleled with a bus, the DECS-150 must be configured with the rated bus voltage.

The nominal operating power input voltage is used in metering calculations.

The ambient temperature setting determines the low-level range on the Takeover OEL settings screen.

Caution

Enabling an inverted bridge output with an exciter which does not require an inverted bridge output will result in equipment damage.

Rated Data

Generator Rated Data

Voltage (V)
120

Current (A)
481.1

Frequency
60 Hz

PF (Power Factor)
0.80

Rating (kVA)
100.0

Rating (kW)
80.00

Rating (kvar)
60.00

Field Rated Data

Voltage - Full Load (V)
100.0

Current - Full Load (A)
10.00

Voltage - No Load (V)
100.0

Current - No Load (A)
7.00

Ambient Temperature

Ambient Temperature
Max Ambient Temperature is 158 degrees Fahrenheit

Bus Rated Data

Voltage (V)
120

Operating Power Input

Power Input Voltage (V)
208.0

Figure 21-2. Rated Data Screen

Sensing Transformer Ratings and Configuration

BESTCOMSPlus Navigation Path: Settings Explorer, System Parameters, Sensing Transformers

DECS-150 configuration includes entry of the primary and secondary values for the transformers that supply machine and bus sensing values to the DECS-150.

The Sensing Transformers screen is illustrated in Figure 21-3.

Machine PT

Voltage settings for the machine PT primary and secondary windings establish the nominal PT voltages expected by the DECS-150. ABC or ACB phase rotation can be accommodated. Options for the machine voltage sensing connections include single-phase (across phases C and A) and three-phase sensing using three-wire delta connections.

Machine CTs

Current settings for the machine CT primary and secondary windings establish the nominal CT current values expected by the DECS-150. DECS-150 sensing current can be obtained from B-phase only or all three machine phases.

Bus PT

Voltage settings for the bus PT primary and secondary windings establish the nominal bus PT voltages expected by the DECS-150. Options for the bus voltage sensing connections include single-phase (across phases A and C) and three-phase sensing using three-wire delta connections.

Sensing Transformers

Generator PT
 Primary Voltage: 120.00
 Secondary Voltage: 120.00

Generator CT
 Primary Current: 200.00
 Secondary Current: 1

Bus PT
 Primary Voltage: 120.00
 Secondary Voltage: 120.00

Sensing Configuration
 Phase Rotation: ABC
 Generator Voltage: 3W-D
 Phase Connection: CT_ABC
 Bus Voltage: 3W-D

Figure 21-3. Sensing Transformers Screen

Startup Functions

BESTCOMSPlus Navigation Path: Settings Explorer, Operating Settings, Startup

DECS-150 startup functions consist of soft start settings as shown in Figure 21-4.

Soft Start

During startup, the soft start function prevents voltage overshoot by controlling the rate of machine terminal voltage buildup (toward the setpoint). Soft start is active in AVR and FCR regulation modes. Soft start behavior is based on two parameters: level and time. The soft start level is expressed as a percentage of the nominal machine terminal voltage and determines the starting point for machine voltage buildup during startup. The Soft Start Time setting defines the amount of time allowed for the buildup of machine voltage during startup. Two groups of soft start settings (primary and secondary) provide for independent startup behavior which is selectable through BESTlogic™ Plus.

The PWM Startup Duty Cycle setting gives the user the ability to adjust the initial startup pulse width of the DECS-150's output to the field of the machine during the soft start sequence.

Startup

Soft Start
 PWM Startup Duty Cycle (%): 0

Primary	Secondary
Soft Start Level (%): 5	Soft Start Level (%): 5
Soft Start Time (s): 5	Soft Start Time (s): 5

Figure 21-4. Startup Screen

Device Information

BESTCOMSPlus Navigation Path: Settings Explorer, General Settings, Device Info

Device information includes user-assigned identification labeling and read-only firmware version information and product information. See Figure 21-5.

Firmware and Product Information

Firmware and product information can be viewed on the Device Info tab of BESTCOMSPi^{us}.

Firmware Information

Firmware information for the DECS-150 includes the Application Part Number, Version Number, and Build Date. Also included is the Boot Code Version. When configuring settings in BESTCOMSPi^{us}® while disconnected from a DECS-150, an Application Version Number setting is available to ensure compatibility between the selected settings and the actual settings available in the DECS-150.

Product Information

Product information for the DECS-150 includes the device model number and serial number.

Device Identification

The user-assigned Device ID (up to 64 alphanumeric characters) can be used to identify DECS-150 controllers in reports and during polling.

The screenshot shows the 'Device Info' tab with two sections: 'Main' and 'Identification'. The 'Main' section contains the following fields:

Application Version (x = 2 or 3)	Serial Number
>= x.05.01	E03445706
Application Version	Application Part Number
3.05.01	9492600058
Boot Code Version	Model Number
3.00.02	DECS-150
Application Build Date	Security Version
12/16/24	1.00

The 'Identification' section contains the following field:

Device ID
DECS-150

Figure 21-5. Device Information

Display Units

BESTCOMSPi^{us} Navigation Path: General Settings, Display Units

When working with DECS-150 settings in BESTCOMSPi^{us}, you have the option of viewing the settings in English or Metric units. The Display Units settings are illustrated in Figure 21-6.

The screenshot shows the 'Display Units' section with a 'System Units' dropdown menu. The current selection is 'English'.

Figure 21-6. Display Units

22 • Security

DECS-150 security is provided in the form of passwords, which control the type of operations allowed by a particular user. Passwords can be tailored to provide access to specific operations. Additional security is available by controlling the type of operations allowed through certain DECS-150 communication ports.

Security settings are uploaded and downloaded separately from the settings and logic. See the *BESTCOMSPlus*® *Software* section for more information on uploading and downloading security.

Password Access

BESTCOMSPlus Navigation Path: Settings Explorer, General Settings, Device Security Setup, User Name Setup

A username and password can be established for one of six functional access areas within the DECS-150. These access areas are listed in Table 22-1 according to rank. A username and password with higher access can be used to gain access to operations controlled by a password with lower access. For example, a settings-level username and password has access to operations protected by the settings-, operator-, control-, and read-level usernames and passwords. This screen cannot be accessed when in Live Mode.

Table 22-1. Password Access Levels and Descriptions

Access Level	Description
Admin (1)	Access to security setup, communications settings, and software upgrades. Includes levels 2, 3, 4, 5, and 6 below.
Design (2)	Access to create and edit programmable logic. Includes levels 3, 4, 5, and 6 below.
Settings (3)	Access to edit settings. Does <u>not</u> include logic settings, security setup, communications settings, and software upgrades. Includes levels 4, 5, and 6 below.
Operator (4)	Access to set date and time, trigger and clear logs, and edit energy values. Includes levels 5 and 6 below.
Control (5)	Access to change setpoints, raise and lower, reset alarms, and preposition. Includes level 6 below.
Read (6)	Access to read all system parameters, metering, and logs. No write access.
None (7)	Lowest access level. All access is denied.

Password Creation and Configuration

Usernames and passwords are created and configured in *BESTCOMSPlus* on the Username Setup screen (Figure 22-1) under the General Settings > Device Security Setup. To create and configure a username and password, perform the following steps:

1. In the *BESTCOMSPlus* settings explorer, select User Name Setup. This selection is located under General Settings, Device Security Setup. When prompted, enter a username of "A" and a password of "A" and log on. This factory-default username and password allows administrator-level access. It is highly recommended that this factory-default password be changed immediately to prevent undesired access.
2. Highlight an "UNASSIGNED" entry in the user list. (Highlighting a previously-established username will display the password and access level for the user. This enables the password and access level for an existing user to be changed.)
3. Enter the desired username (up to a 16-character label that may include upper and lowercase letters, numbers, and special characters).

4. Enter the desired password for the user (up to a 16-character label that may include upper and lowercase letters, numbers, and special characters).
5. Reenter the password created in step 4 to verify the password.
6. Select the maximum allowed access level for the user (Read, Control, Operator, Settings, Design, or Admin).
7. If a maximum duration is desired for the user's access, enter the limit (0 to 50,000 days). Otherwise, leave the expiration value at zero.
8. Click the Save User button to save the user settings.
9. Open the Communication menu, and click Upload Security to Device.
10. BESTCOMSPi^{us} notifies you when the security upload is successful.

User Name	Max Access Level
A	Admin
UNASSIGNED	Read
UNASSIGNED	Read
UNASSIGNED	Read
UNASSIGNED	Read

Selected User Information

User Name: A

Password: A

Verify Password: A

Maximum Access Level Allowed: Admin

Days to Expiration (0 - No Password Expiration): 0

Buttons: Save User, Delete User

Figure 22-1. User Name Setup Screen

Port Security

BESTCOMSPi^{us} Navigation Path: Settings Explorer, General Settings, Device Security Setup, Port Access Setup

An additional dimension of security is provided by the ability to restrict the control available through the DECS-150 communication ports. At any given time, only one port can be in use with read or higher access. For example, if a user gains settings access at one port, users at other ports will be able to gain no higher than read access until the user with settings access logs off. This screen cannot be accessed when in Live Mode.

Port Access Configuration

Communication port access is configured in BESTCOMSPi^{us} on the Port Access Setup tab (Figure 22-2) of the Device Security Setup area. To configure communication port access, perform the following steps:

1. In the BESTCOMSPi^{us} settings explorer, select Port Access Setup. This selection is located under General Settings, Device Security Setup. When prompted, enter a username of "A" and a password of "A" and log on. This factory-default username and password allows administrator-level access. It is highly recommended that this factory-default password be changed immediately to prevent undesired access.
2. Highlight the desired communication port in the port list.

3. Select the unsecured access level for the port (None, Read, Control, Operator, Settings, Design, or Admin).
4. Select the secured access level for the port (None, Read, Control, Operator, Settings, Design, or Admin).
5. Save the configuration by clicking the Save Port button.
6. Open the Communication menu, and click Upload Security to Device.
7. BESTCOMSPi^{us}® notifies you when the security upload is successful.

Port	Unsecured Access	Secured Access
BESTCOMSPi ^{us} via Ethernet	Read	Admin
BESTCOMSPi ^{us} via USB	Read	Admin
Modbus via Ethernet	Read	Admin

Selected Port Information

Unsecured Access Level: Read

Secured Access Level: Admin

Figure 22-2. Port Access Configuration Settings

Login and Access Controls

BESTCOMSPi^{us} Navigation Path: Settings Explorer, General Settings, Device Security Setup, Access Control

Additional controls are available to limit login time and login attempts. These control settings are illustrated in Figure 22-3.

Access Timeout

The Access Timeout Delay setting maintains security by automatically withdrawing password access if a user neglects to log out. If no activity is seen for the duration of the access timeout setting, password access is automatically withdrawn.

Login Failure

The Login Attempts setting limits the number of times that login can be attempted. The Login Time Window setting limits the length of time permitted during the login process. If login is unsuccessful, access is blocked for the duration of the login Lockout Time setting.

System In Use Notification

When enabled, this feature warns users that they are connected to a functioning system and their actions can have severe consequences. A pop-up window in BESTCOMSPi^{us} will appear displaying a custom message prior to authenticating a login if the system is in use. A DECS-150 system is determined “In Use” when the Generator Below 10Hz logic bit is FALSE and the unit is not in Stop mode.

Figure 22-3. Access Control Screen

Viewing the Security Log

BESTCOMSPlus Navigation Path: Metering Explorer, Reports, Security Log

The DECS-150 records information about user logins, including the port used to log in, the access level granted, the type of action performed, and the time of logout, and creates security logs. A log will also be triggered when a user attempts to log in but fails due to an invalid username or incorrect password.

A maximum of 200 entries are stored in nonvolatile memory. When a new entry is generated, the DECS-150 discards the oldest of the 200 entries and replaces it with a new one.

Use the Metering Explorer to open the Reports, Security Log screen. If an active connection to a DECS-150 is present, the security log will automatically download. Using the Options button, you can copy, print, or save the security log. The Refresh button is used to refresh/update the security log. The Clear button clears the security log. The Toggle Sorting button enables sorting. Click on a column header to sort. See Figure 22-4.

Port	Username	Access Level	Login Time	Logout Time	Action
Bestcoms Via Ethernet	A	Admin Access	2008-01-01 00:00:24.000	2008-01-01 00:05:29.672	Activate
Bestcoms Via Ethernet	A	Admin Access	2008-01-01 00:00:37.000	NA	None
Bestcoms Via Ethernet	A	Admin Access	2008-01-01 00:00:37.418	NA	None
Bestcoms Via Ethernet	A	Admin Access	2008-01-01 00:00:59.826	NA	None
Bestcoms Via Ethernet	A	Admin Access	2008-01-01 00:01:00.537	NA	None
Bestcoms Via Ethernet	A	Admin Access	2008-01-01 00:01:03.131	NA	None
Bestcoms Via Ethernet	A	Admin Access	2008-01-01 00:01:04.993	NA	None
Bestcoms Via Ethernet	A	Admin Access	2008-01-01 00:01:05.111	2008-01-01 00:13:38.352	Save
Bestcoms Via Ethernet	A	Admin Access	2008-01-01 00:01:11.961	2008-01-01 00:36:08.238	Save
Bestcoms Via Ethernet	A	Admin Access	2008-01-01 00:06:02.839	2008-01-01 00:16:07.411	Save
Bestcoms Via Ethernet	A	Admin Access	2008-01-01 00:13:08.943	2008-01-01 00:13:53.707	Save
HMI Local	A	Read Access	2008-01-01 00:16:00.434	NA	None
HMI Local	A	Admin Access	2008-01-01 00:16:13.569	NA	None
Bestcoms Via Ethernet	A	Read Access	2008-01-01 00:17:29.641	NA	None
Bestcoms Via Ethernet	A	Admin Access	2008-01-01 00:17:44.417	2008-01-01 00:17:43.18	Save

Figure 22-4. Security Log

23 • Timekeeping

The DECS-150 provides a real-time clock with an internal backup battery. The backup battery will maintain the clock for approximately five years depending on conditions.

The clock is used by the logging functions to timestamp events. BESTCOMSPlus® clock settings are shown in Figure 23-1.

BESTCOMSPlus Navigation Path: Settings Explorer, General Settings, Clock Setup

Time and Date Format

Time zone offset settings provide the necessary offset from the coordinated universal time (UTC) standard. Central Standard Time is six hours and zero minutes behind (–6, 0) UTC, and is the default setting.

Clock display settings enable you to configure the time and date reported by the DECS-150 to match the conventions used in your organization/facility. The reported time can be configured for either the 12- or 24-hour format with the Time Format setting. The Date Format setting configures the reported date for one of three available formats: MM-DD-YYYY, DD-MM-YYYY, or YYYY-MM-DD.

Daylight Saving Time Adjustments

The DECS-150 can automatically compensate for the start and end of daylight saving time (DST) on a fixed- or floating-date basis. A fixed-date, for example, is March 2, and an example of a floating-date is, “Second Sunday of March”. DST compensation can be made with respect to your local time or coordinated universal time (UTC). DST start and end points are fully configurable and include a bias adjustment.

The screenshot shows the 'Clock Setup' configuration screen. It is divided into several sections:

- Time Zone Offset Setup:** Includes 'Time Zone Hour Offset' (set to 0) and 'Time Zone Minute Offset' (set to 0).
- Clock Display Setup:** Includes 'Time Format' (set to '24 Hour Mode') and 'Date Format' (set to 'YYYY-MM-DD').
- Daylight Saving Time Setup:**
 - DST Configuration:** Set to 'Floating Dates'.
 - Start/End Time Reference:** Radio buttons for 'Respective to Local Time' (selected) and 'Respective to UTC Time'.
 - Start Day:** Month: 'March', Occurrence of Day: 'Second', Weekday: 'Sunday', Hour: '2', Minute: '0'.
 - End Day:** Month: 'November', Occurrence of Day: 'First', Weekday: 'Sunday', Hour: '2', Minute: '0'.
- Bias Setup:** Includes 'Hour' (set to 1) and 'Minute' (set to 0).

Figure 23-1. Clock Setup Screen

Backup Battery for the Real-Time Clock

The backup battery for the real time clock is a standard feature of the DECS-150. A battery is used to maintain clock function during loss of operating power. In mobile substation and other applications, the primary battery system that supplies DECS-150 operating power may be disconnected for extended

periods (weeks, months) between uses. Without battery backup for the real time clock, clock functions will cease if battery input power is removed.

The backup battery has a life expectancy of approximately five years depending on conditions. After this time, you should contact Basler Electric to order a new battery, Basler Electric P/N 38526.

Caution

Replacement of the backup battery for the real-time clock should be performed only by qualified personnel.

Do not short-circuit the battery, reverse battery polarity, or attempt to recharge the battery. Observe polarity markings next to the battery socket when inserting a new battery. The battery polarity must be correct in order to provide backup for the real-time clock.

It is recommended that the battery be removed if the DECS-150 is to be operated in a salt-fog environment. Salt-fog is known to be conductive and may short-circuit the battery.

Notes

Failure to replace the battery with Basler Electric P/N 38526 may void the warranty.

The time must be reset after replacing the battery. Time settings such as 12/24 hour format are not affected.

Battery Replacement Procedure

The battery access is located on the back of the DECS-150. See the *Terminals and Connectors* section for battery location.

- Step 1: Remove the DECS-150 from service.
- Step 2: Locate the battery socket on the back of the DECS-150. Remove the old battery. Consult your local ordinance for proper battery disposal.
- Step 3: Insert the new battery so that the polarity markings on the battery match the polarity markings on the battery socket.
- Step 4: Return the DECS-150 to service.

24 • Testing

Testing of the DECS-150's regulation and optional power system stabilizer (style xPxxx) performance is possible through the integrated analysis tools of BESTCOMSPPlus®.

Real-Time Metering Analysis

BESTCOMSPPlus Navigation Path: Metering Explorer, Analysis

Proper voltage regulator performance is critical to power system stabilizer performance. Step response measurements of the voltage regulator should be performed to confirm the AVR gain and other critical parameters. A transfer function measurement between terminal voltage reference and terminal voltage should be performed with the machine operating at very low load. This test provides an indirect measurement of the PSS phase requirement. As long as the machine is operating at very low load, the terminal voltage modulation does not produce significant speed and power changes.

The BESTCOMSPPlus Real-Time Metering Analysis screen can be used to perform and monitor online AVR and PSS testing. Four plots of user-selected data can be generated and the logged data can be stored in a file for later examination. BESTCOMSPPlus must be in Live Mode in order to start plotting. Live Mode is found under the Options menu on the lower menu bar. RTM Analysis screen controls and indications are illustrated in Figure 24-1.

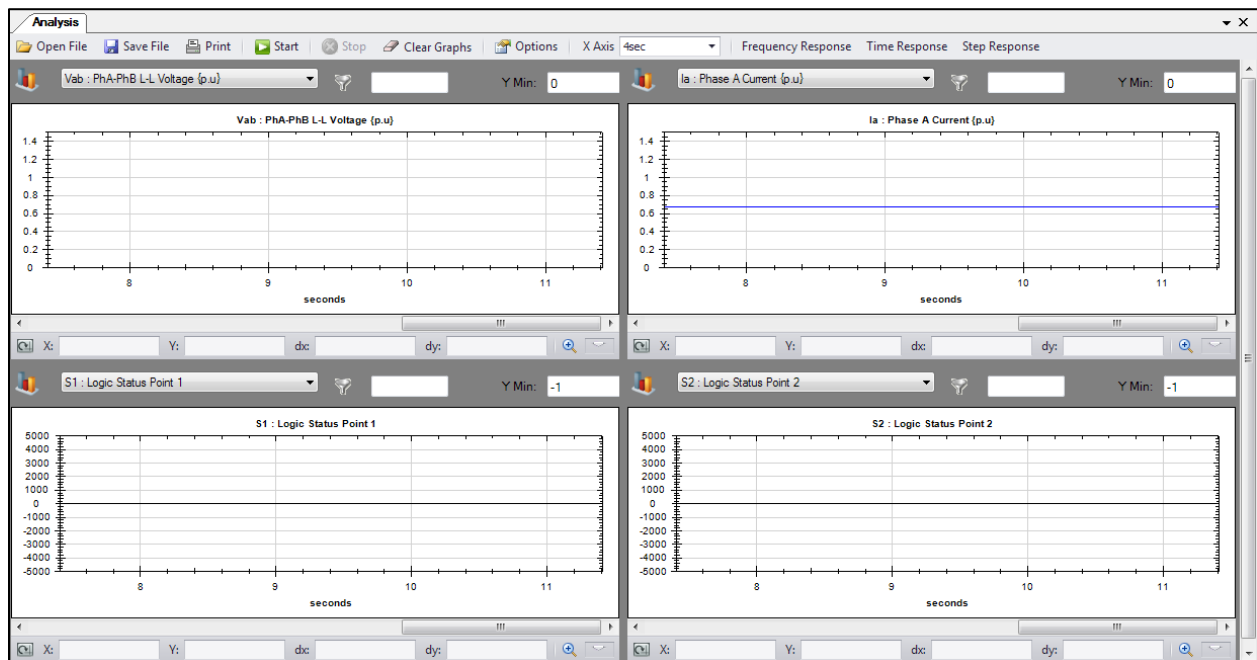


Figure 24-1. RTM Analysis Screen

With the RTM Analysis screen controls, you can:

- Select the parameters to be graphed
- Adjust the resolution of the graph x axis and the range of the graph y axis
- Start and stop plot captures
- Open an existing graph file, save a captured plot in a graph file, and print a captured graph

Graph Parameters

Any four of the following parameters may be selected for plotting in the graph areas.

- APC Error to PI
- APC Integrator state
- APC PI output
- Auxiliary voltage input (Vaux)
- Average line current (Iavg)
- Average line-to-line voltage (Vavg)
- AVR error signal (ErrIn)
- AVR output
- Bus frequency (B Hz)
- Bus voltage (Vbus)
- Compensated frequency deviation (CompF)
- Control output (CntOp)
- Cross-current input (Iaux)
- Desired APC Reference
- Droop
- FCR error
- FCR state
- FCR output
- Field current (I_{fd})
- Field voltage (V_{fd})
- Filtered mechanical power (MechP)
- Final PSS output (Pout)
- Frequency response signal (Test)
- Generator/Motor frequency (G/M Hz)
- Grid connect state
- Grid code test signal
- Internal state (TrnOp)
- Lead-lag #1 (x15)
- Lead-lag #2 (x16)
- Lead-lag #3 (x17)
- Lead-lag #4 (x31)
- Logic Limiter Washout Filter
- Logic Status Point 1 (S1)
- Logic Status Point 2 (S2)
- Logic Status Point 3 (S3)
- Logic Status Point 4 (S4)
- Logic Status Point 5 (S5)
- Logic Status Point 6 (S6)
- LVRT Desired var Reference
- LVRT var Reference
- Mechanical power (x10)
- Mechanical power (x11)
- Mechanical power (x7)
- Mechanical power (x8)
- Mechanical power (x9)
- Negative sequence current (I₂)
- Negative sequence voltage (V₂)
- Network Load Share
- Null Balance Level (Null Balance)
- Null Balance State (Null State)
- OEL controller output (OelOutput)
- OEL reference
- OEL state
- Phase A current (I_a)
- Phase A to B, line-to-line voltage (V_{ab})
- Phase B current (I_b)
- Phase B to C, line-to-line voltage (V_{bc})
- Phase C current (I_c)
- Phase C to A, line-to-line voltage V_{ca}
- Position Indication (PositionInd)
- Positive sequence current (I₁)
- Positive sequence voltage (V₁)
- Post-limit output (Post)
- Power factor (PF)
- Power HP #1 (x5)
- Power Input
- Pre-limit output (Prelim)
- PSS electrical power (PssW)
- PSS terminal voltage (V_{tmag})
- Reactive power (var)
- Real power (W)
- SCL controller output (SciOutput)
- SCL reference
- SCL state
- SCL PF reference
- Speed HP #1 (x2)
- Synthesized speed (Synth)
- Terminal frequency deviation (TermF)
- Terminal Voltage Low Pass Filter
- Terminal Voltage Ramp Limiter
- Time response signal (Ptest)
- Torsional filter #1 (Tflt1)
- Torsional filter #2 (x29)
- Total power (VA)
- Transfer Output
- UEL controller output (UelOutput)
- UEL reference
- UEL state
- Var/PF error
- Var/PF state
- Var/PF output
- Washed out power (WashP)
- Washed out speed (WashW)

Frequency Response

Frequency response testing functions are available by clicking the RTM Analysis screen Frequency Response button. Frequency Response screen functions are illustrated in Figure 24-2 and described as follows.

Test Mode

Frequency response testing may be performed in Manual or Auto mode. In Manual mode, a single frequency can be specified to obtain the corresponding magnitude and phase responses. In Auto mode, BESTCOMSP^{Plus} will sweep the range of frequencies and obtain the corresponding magnitude and phase responses.

Manual Test Mode Options

Manual test mode options include settings to select the frequency and magnitude of the applied test signal. The Time Delay setting selects the time after which the magnitude and phase response corresponding to the specified frequency is computed. This delay allows transients to settle before computations are made.

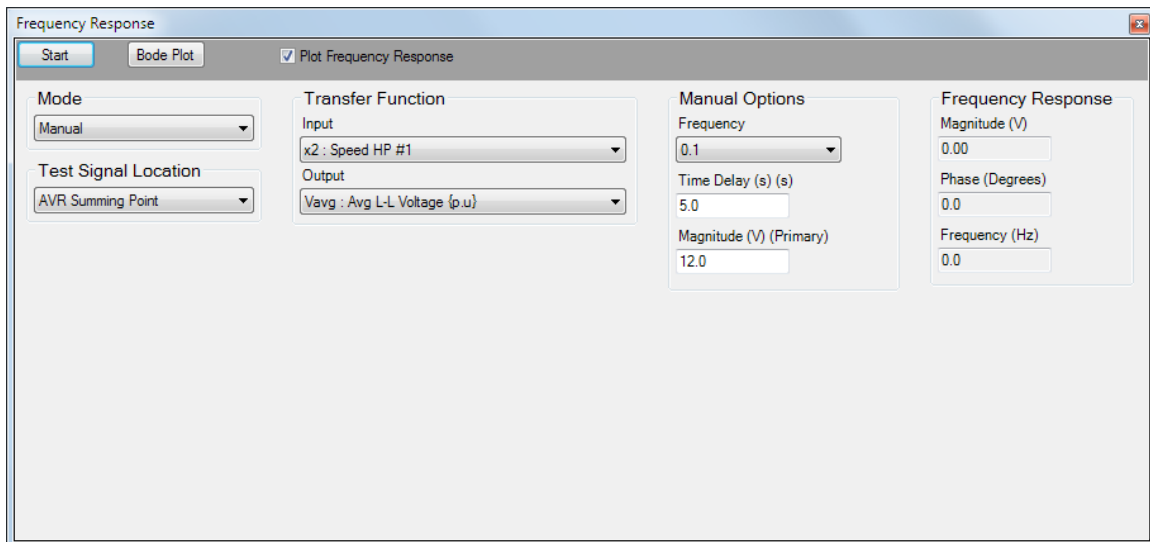


Figure 24-2. Frequency Response Screen

Auto Test Mode Options

Automatic test mode options include settings to select the minimum frequency, maximum frequency, and magnitude of the sinusoidal wave that is applied during a frequency response test.

Bode Plotting

A Bode plot can be printed, opened, and saved in graph (.gph) format.

Test Signal Location

The point in the DECS-150 logic circuitry where a signal is injected for analysis of magnitude and phase responses is selectable. Signal points include AVR Summing Point, PID Block Output, AVR PID Input, PSS Compensation Frequency, PSS Electric Power, and Manual PID Input.

Transfer Function

The type of input signal to be injected and output point are selectable, and include:

- AvrOut
- B Hz: Bus Frequency {Hz}
- CntOp: Control Output {pu}

- CompF: Compensated Frequency Deviation
- ErrIn: AVR Error Signal
- FcrErr
- FcrOut
- G/M Hz: Generator/Motor Frequency {Hz}
- I1: Positive Sequence Current {pu}
- I2: Negative Sequence Current {pu}
- Ia: Phase A Current {pu}
- Iaux: Cross Current Input {pu}
- Iavg: Ave Line Current {pu}
- Ib: Phase B Current {pu}
- Ic: Phase C Current {pu}
- Ifd: Field Current {pu}
- kVA: Total Power {pu}
- kvar: Reactive Power {pu}
- kW: Real Power {pu}
- MechP: Filtered Mechanical Power
- Network Load Share
- NullBalance: Null Balance Level
- OelOutput: OEL Controller Output
- PF: Power Factor
- Post: Post-Limit Output {pu}
- POut: Final PSS Output {pu}
- Prelim: Pre-Limit Output {pu}
- PsskW: PSS Electric Power {pu}
- Ptest: Time Response Signal {pu}
- SclOutput: SCL Controller Output
- Synth: Synthesized Speed {pu}
- TermF: Terminal Frequency Deviation
- Test: Frequency Response Signal {pu}
- Tflt1: Torsional Filter #1 {pu}
- TrnOp: Internal State {pu}
- UelOutput: UEL Controller Output
- V1: Positive Sequence Voltage {pu}
- V2: Negative Sequence Voltage {pu}
- Vab: PhA-PhB L-L Voltage {pu}
- Var/PfErr
- Var/PfOut
- Vaux: Aux Voltage Input {pu}
- Vavg: Ave L-L Voltage {pu}
- Vbc: PhB-PhC L-L Voltage {pu}
- Vbus: Bus Voltage {pu}
- Vca: PhC-PhA L-L Voltage {pu}
- Vfd: Field Voltage {pu}
- Vtmag: PSS Term Voltage
- WashP: Washed Out Power
- WashW: Washed Out Speed {pu}
- x10: Mechanical Power LP #3
- x11: Mechanical Power LP #4
- x15: Lead-Lag #1 {pu}
- x16: Lead-Lag #2 {pu}
- x17: Lead-Lag #3 {pu}
- x2: Speed HP #1
- x29: Torsional Filter #2 {pu}
- x31: Lead-Lag #4 {pu}
- x5: Power HP #1 {pu}
- x7: Mechanical Power {pu}
- x8: Mechanical Power LP #1
- x9: Mechanical Power LP #2

Frequency Response

Read-only frequency response fields indicate the magnitude response, phase response, and test signal frequency. The magnitude response and phase response corresponds to the test signal previously applied. The test frequency value reflects the frequency of the test signal currently being applied.

Caution

Exercise caution when performing frequency response testing on a generator connected to the grid. Frequencies that are close to the resonant frequency of the machine or neighboring machines are to be avoided. Frequencies above 3 Hz may correspond to the lowest shaft torsional frequencies of a generator. A torsional profile for the machine should be obtained from the manufacturer and consulted before conducting any frequency response tests.

Time Response

Tests should be performed at various load levels to confirm that the input signals are calculated or measured correctly. Since the PSS function uses compensated terminal frequency in place of speed, the derived mechanical power signal should be examined carefully to ensure that it does not contain any components at the electromechanical oscillation frequencies. If such components are present, it indicates that the frequency compensation is less than ideal, or that the machine inertia value is incorrect.

PSS test signal configuration settings are provided on the Time Response screen shown in Figure 24-3. Click the RTM Analysis screen's Time Response button to access this screen.

Signal Input

Signal input selections determine the point in the PSS circuitry where the test signal is applied. Test points include AVR Summing, PSS Comp Frequency, PSS Electric Power, PSS Derived Speed, Manual Summing, and var/PF.

A time delay is provided to delay the start of a PSS test after the Time Response screen Start button is clicked.

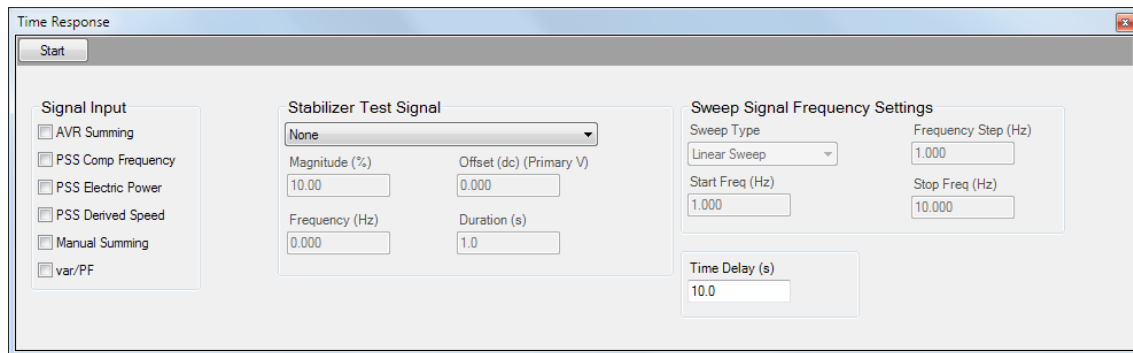


Figure 24-3. Time Response Screen

Test Signal Characteristics

Test signal characteristics (magnitude, offset, frequency, and duration) can be adjusted according to the type of test signal selected.

Magnitude

The test signal magnitude is expressed as a percentage and excludes the gain of externally-applied signals.

Offset

A dc offset can be applied to the PSS test signal. The offset is expressed as a per-unit value used in proper context wherever the test signal is applied. A dc offset cannot be applied to a Step test signal.

Frequency

The test signal frequency can be adjusted as desired for Step and Sine test signals. See *Swept Sine Test Signal* for information about configuring the frequency attributes of swept sine test signals.

Duration

A duration setting controls the total test duration for Sine and External test signals. For Step test signals, the duration setting determines the “on” period of the signal. The duration setting does not apply to Swept Sine signals.

Swept Sine Test Signal

Swept Sine test signals employ a unique set of characteristics that include the sweep style, frequency step, and start/stop frequencies.

Sweep Type

A Swept Sine test signal can be configured as linear or logarithmic.

Start and Stop Frequencies

The range of a Swept Sine test signal is determined by Start Frequency and Stop Frequency settings.

Frequency Step

The frequency of a Swept Sine test signal is incremented according to the sweep type used. For linear sweeps, the test signal frequency is incremented by “step” every half-cycle of the system frequency. For logarithmic sweeps, the test signal frequency is multiplied by $1.0 + \text{step}$ every half-cycle of the system frequency.

Step Response Analysis

A standard technique for verifying overall system response is through step response measurements. This involves exciting the local electromechanical oscillation modes through a fixed step change in the AVR reference. Damping and frequency of oscillation can be measured directly from recordings of machine speed and power for different operating conditions and settings. Normally this test is performed with variations of the following:

- Machine active and reactive power loading
- Stabilizer gain
- System configuration (e.g., lines out of service)
- Stabilizer parameters (e.g., phase lead, frequency compensation)

As the stabilizer gain is increased, the damping should increase continuously while the natural frequency of oscillation should remain relatively constant. Large changes in the frequency of oscillation, a lack of improvement in damping, or the emergence of new modes of oscillation are all indications of problems with the selected settings.

Step response testing is performed using the Step Response Analysis screen. This screen (Figure 24-4) is accessed by clicking the Step Response button in the RTM Analysis window. The Step Response Analysis screen consists of:

- Metering fields: generator/motor VA, total vars and PF, field voltage, and field current
- An alarms window that displays any active alarms triggered by a step change
- Control buttons to start and stop step response analysis and a button to close the screen
- A checkbox to select triggering of a data record when a setpoint step change is performed
- Tabs for controlling the application of step changes to the AVR, FCR, var, and PF setpoints. Tab functions are described in the following paragraphs.

Note

If logging is in progress, another log cannot be triggered.

Response characteristics displayed on the Step Response Analysis screen are not automatically updated when the DECS-150 operating mode is switched externally. The screen must be manually updated by exiting and then reopening the screen.

AVR and FCR Tabs

The AVR and FCR tabs are similar in their controls that enable the application of step changes to their respective setpoints. AVR tab controls are illustrated in Figure 24-4. AVR and FCR tab controls operate as follows.

Step changes that increase or decrease the setpoint are applied by clicking the increment (up arrow) or decrement (down arrow) button. Step-change setting fields (one for increase and one for decrease) establish the percent change in the setpoint that occurs when the increment or decrement button is clicked. A read-only setpoint field indicates the current setpoint and what the setpoint will be when a step change occurs. A button is provided to return the setpoint to its original value. This original value is the setpoint established in the Setpoints section of the BESTCOMSP^{lus} settings explorer and is displayed in the read-only field adjacent to the button.

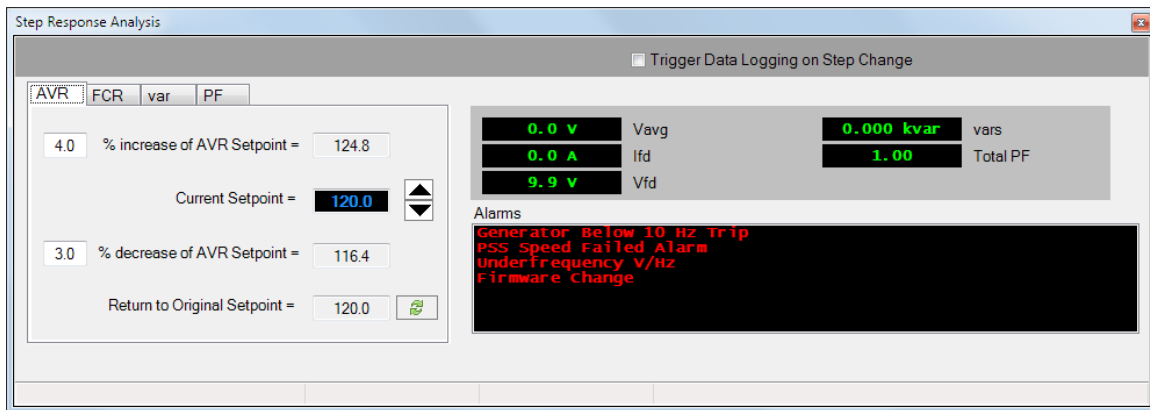


Figure 24-4. Step Response Analysis - AVR Tab

Var and PF Tabs

The var and PF tabs are similar in their controls that enable the application of step changes to their respective setpoints. PF tab controls are illustrated in Figure 24-5. Var and PF tab controls operate as follows.

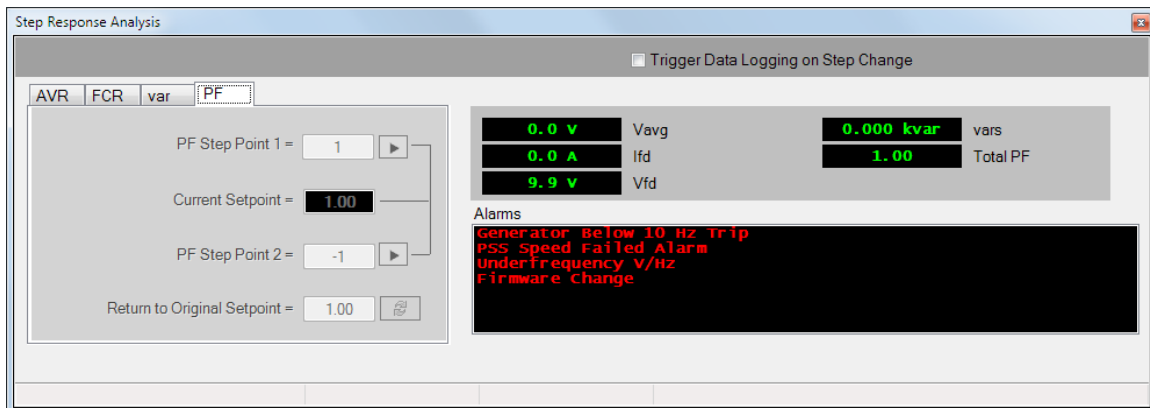


Figure 24-5. Step Response Analysis - PF Tab

Step changes that increase or decrease the setpoint can be applied by clicking the increment (up arrow) or decrement (down arrow) button. Step-change setpoints can be entered in two setting fields. Clicking the right-arrow button beside one of the two fields initiates a step change to the corresponding setpoint value. A button is provided to return the setpoint to its original value before any step changes were invoked. This original value is the setpoint established in the Setpoints section of the BESTCOMSPPlus settings explorer and is displayed in the read-only field adjacent to the button.

Analysis Options

Options are provided to arrange the layout of plots and adjust graph display.

Layout Tab

Up to four data plots may be displayed in three different layouts on the RTM screen. Place a check in the Cursors Enabled box to enable cursors used for measuring between two horizontal points. See Figure 24-6.

Graph Display Tab

Options are provided to adjust graph history and poll rate. Graph height sets the displayed graphs to a fixed height in pixels. When the Auto Size box is checked, all displayed graphs are automatically sized to equally fit the available space. History length is selectable from 1 to 30 minutes. Poll rate is adjustable

between 100 to 500 milliseconds. Lowering the history and poll rate may also result in improved PC performance while plotting.

Place a check in the Sync Graph Scrolling box to sync scrolling between all graphs when any horizontal scroll bar is moved. See Figure 24-7.

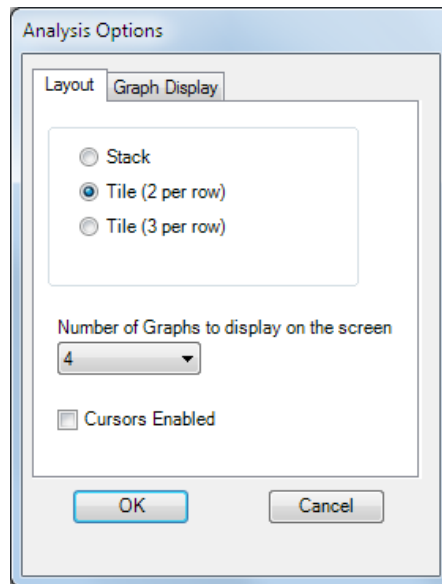


Figure 24-6. Analysis Options Screen, Layout Tab

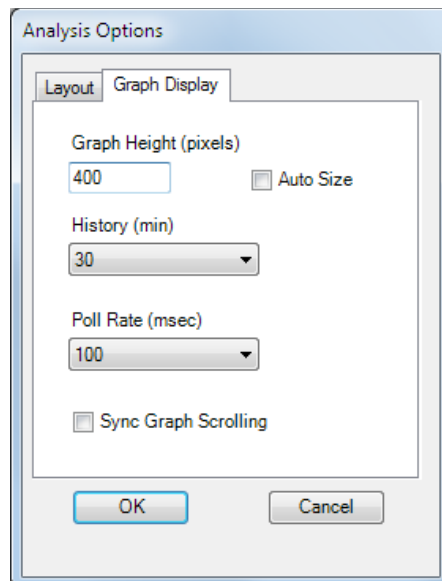


Figure 24-7. Analysis Options Screen, Graph Display Tab

25 • Modbus® Communication

Introduction

This document describes the Modbus® communications protocol employed by DECS-150 systems and how to exchange information with DECS-150 systems over a Modbus network. DECS-150 systems communicate by emulating a subset of the Modicon 984 Programmable Controller.

Caution

This product contains one or more *nonvolatile memory* devices. Nonvolatile memory is used to store information (such as settings) that needs to be preserved when the product is power-cycled or otherwise restarted. Established nonvolatile memory technologies have a physical limit on the number of times they can be erased and written. In this product, the limit is 100,000 erase/write cycles. During product application, consideration should be given to communications, logic, and other factors that may cause frequent/repeated writes of settings or other information that is retained by the product. Applications that result in such frequent/repeated writes may reduce the useable product life and result in loss of information and/or product inoperability.

Modbus communications use a master-slave technique in which only the master can initiate a transaction. This transaction is called a query. When appropriate, a slave (DECS-150) responds to the query. When a Modbus master communicates with a slave, information is provided or requested by the master. Information residing in the DECS-150 is grouped categorically as follows:

- General
- Security
- Binary Points
- Metering
- Limiters
- Setpoints
- Global Settings
- Configuration Settings
- Protection Settings
- Gains
- PSS

All supported data can be read as specified in the Register Table. Abbreviations are used in the Register Table to indicate the register type. Register types are:

- Read/Write = RW
- Read Only = R

When a slave receives a query, the slave responds by either supplying the requested data to the master or performing the requested action. A slave device never initiates communications on the Modbus and will always generate a response to the query unless certain error conditions occur. The DECS-150 is designed to communicate on the Modbus network only as slave devices.

Refer to the *Communication* section for Modbus communication setup and the *Terminals and Connectors* section for wiring.

Message Structure

Device Address Field

The device address field contains the unique Modbus address of the slave being queried. The addressed slave repeats the address in the device address field of the response message. This field is 1 byte.

Although Modbus protocol limits a device address from 1 - 247. The address is user-selectable at installation and can be altered during real-time operation.

Function Code Field

The function code field in the query message defines the action to be taken by the addressed slave. This field is echoed in the response message and is altered by setting the most significant bit (MSB) of the field to 1 if the response is an error response. This field is 1 byte in length.

The DECS-150 maps all available data into the Modicon 984 holding register address space supports the following function codes:

- Function 03 (03 hex) - read holding registers
- Function 06 (06 hex) - preset single register
- Function 08 (08 hex), subfunction 00 - diagnostics: return query data
- Function 08 (08 hex), subfunction 01 - diagnostics: restart communications option
- Function 08 (08 hex), subfunction 04 - diagnostics: force listen only mode
- Function 16 (10 hex) - preset multiple registers

Data Block Field

The query data block contains additional information needed by the slave to perform the requested function. The response data block contains data collected by the slave for the queried function. An error response will substitute an exception response code for the data block. The length of this field varies with each query.

Error Check Field

The error check field provides a method for the slave to validate the integrity of the query message contents and allows the master to confirm the validity of response message contents. This field is 2 bytes.

Modbus Modes of Operation

A standard Modbus network offers the Modbus TCP mode for communication. To enable editing over Modbus TCP, the unsecured access level for the port must be configured to the appropriate access level. See the *Security* section of this manual for more information on security and access levels. These two modes of operation are described below.

A master can query slaves individually or universally. A universal ("broadcast") query, when allowed, evokes no response from any slave device. If a query to an individual slave device requests actions unable to be performed by the slave, the slave response message contains an exception response code defining the error detected. Exception response codes are quite often enhanced by the information found in the "Error Details" block of holding registers.

The Modbus protocol defines a simple Protocol Data Unit (PDU) independent of the underlying communication layers. The mapping of the Modbus protocol on specific buses or networks can introduce some additional fields on the Application Data Unit (ADU). See Figure 25-1.

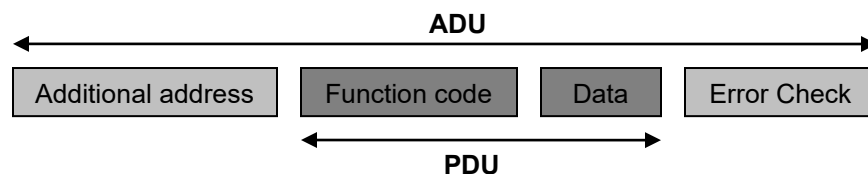


Figure 25-1. General Modbus Frame

The client that initiates a Modbus transaction builds the Modbus Application Data Unit. The function code indicates to the server which kind of action to perform.

Modbus on TCP/IP

Application Data Unit

The following describes the encapsulation of a Modbus request or response when it is carried on a Modbus TCP/IP network. See Figure 25-2.

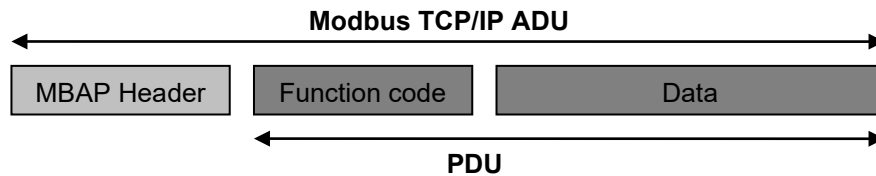


Figure 25-2. Modbus Request/Response Over TCP/IP

A dedicated header is used on TCP/IP to identify the Modbus Application Data Unit. It is called the MBAP header (Modbus Application Protocol header).

This header provides some differences compared to the Modbus RTU application data unit used on a serial line:

- The Modbus 'slave address' field usually used on Modbus Serial Line is replaced by a single byte 'Unit Identifier' within the MBAP header. The 'Unit Identifier' is used to communicate via devices such as bridges, routers, and gateways that use a single IP address to support multiple independent Modbus end units.
- All Modbus requests and responses are designed in such a way that the recipient can verify that a message is finished. For function codes where the Modbus PDU has a fixed length, the function code alone is sufficient. For function codes carrying a variable amount of data in the request or response, the data field includes a byte count.
- When Modbus is carried over TCP, additional length information is carried in the MBAP header to allow the recipient to recognize message boundaries even if the message has been split into multiple packets for transmission. The existence of explicit and implicit length rules and use of a CRC-32 error check code (on Ethernet) results in an infinitesimal chance of undetected corruption to a request or response message.

MBAP Header Description

The MBAP Header contains the fields listed in Table 25-1.

Table 25-1. MBAP Header Fields

Fields	Length	Description	Client	Server
Transaction Identifier	2 Bytes	Identification of a Modbus request/response transaction.	Initialized by the client.	Recopied by the server from the received request.
Protocol Identifier	2 Bytes	0 = Modbus protocol.	Initialized by the client.	Recopied by the server from the received request.
Length	2 Bytes	Number of following bytes.	Initialized by the client (request).	Initialized by the server (response).
Unit Identifier	1 Byte	Identification of a remote slave connected on a serial line or on other buses.	Initialized by the client.	Recopied by the server from the received request.

The header is 7 bytes long:

- *Transaction Identifier* – Used for transaction pairing, the Modbus server copies in the response the transaction identifier of the request.

- *Protocol Identifier* – Used for intra-system multiplexing. The Modbus protocol is identified by the value 0.
- *Length* – A byte count of the following fields, including the Unit Identifier and data fields.
- *Unit Identifier* – Used for intra-system routing purpose. It is typically used to communicate to a Modbus or a Modbus serial line slave through a gateway between an Ethernet TCP/IP network and a Modbus serial line. This field is set by the Modbus Client in the request and must be returned with the same value in the response by the server.

Note: All Modbus TCP ADU are sent via TCP on registered port 502.

Error Handling and Exception Responses

Any query received that contains a non-existent device address, a framing error, or CRC error is ignored. No response is transmitted. Queries addressed to the DECS-150 with an unsupported function or illegal values in the data block result in an error response message with an exception response code. The exception response codes supported by the DECS-150 are provided in Table 25-2.

Table 25-2. Supported Exception Response Codes

Code	Name	Description
01	Illegal Function	The query Function/Subfunction Code is unsupported; query read of more than 125 registers; query preset of more than 100 registers.
02	Illegal Data Address	A register referenced in the data block does not support queried read/write; query preset of a subset of a numerical register group.
03	Illegal Data Value	A preset register data block contains an incorrect number of bytes or one or more data values out of range.

DECS-150 Modbus® via Ethernet

Modbus can communicate through Ethernet if the IP address of the DECS-150 is configured as described in the *Communications* section of this manual.

Detailed Message Query and Response

A detailed description of DECS-150 supported message queries and responses is provided in the following paragraphs.

Read Holding Registers

Query

This query message requests a register or block of registers to be read. The data block contains the starting register address and the quantity of registers to be read. A register address of N will read holding register N+1. If the query is a broadcast (device address = 0), no response message is returned.

Device Address
 Function Code = 03 (hex)
 Starting Address Hi
 Starting Address Lo
 No. of Registers Hi
 No. of Registers Lo
 CRC Hi error check
 CRC Lo error check

The number of registers cannot exceed 125 without causing an error response with the exception code for an illegal function.

Response

The response message contains the data queried. The data block contains the block length in bytes followed by the data (one Data Hi byte and one Data Lo byte) for each requested register.

Reading an unassigned holding register returns a value of zero.

Device Address
 Function Code = 03 (hex)
 Byte Count
 Data Hi (For each requested register, there is one Data Hi and one Data Lo.)
 Data Lo
 .
 .
 Data Hi
 Data Lo
 CRC Hi error check
 CRC Lo error check

Return Query Data

This query contains data to be returned (looped back) in the response. The response and query messages should be identical. If the query is a broadcast (device address = 0), no response message is returned.

Device Address
 Function Code = 08 (hex)
 Subfunction Hi = 00 (hex)
 Subfunction Lo = 00 (hex)
 Data Hi = xx (don't care)
 Data Lo = xx (don't care)
 CRC Hi error check
 CRC Lo error check

Restart Communications Option

This query causes the remote communications function of the DECS-150 to restart, terminating an active listen only mode of operation. No effect is made upon primary relay operations. Only the remote communications function is affected. If the query is a broadcast (device address = 0), no response message is returned.

If the DECS-150 receives this query while in the listen only mode, no response message is generated. Otherwise, a response message identical to the query message is transmitted prior to the communications restart.

Device Address
 Function Code = 08 (hex)
 Subfunction Hi = 00 (hex)
 Subfunction Lo = 01 (hex)
 Data Hi = xx (don't care)
 Data Lo = xx (don't care)
 CRC Hi error check
 CRC Lo error check

Listen Only Mode

This query forces the addressed DECS-150 to the listen only mode for Modbus communications, isolating it from other devices on the network. No responses are returned.

While in the listen only mode, the DECS-150 continues to monitor all queries. The DECS-150 does not respond to any other query until the listen only mode is removed. All write requests with a query to Preset Multiple Registers (Function Code = 16) are also ignored. When the DECS-150 receives the restart communications query, the listen only mode is removed.

Device Address
 Function Code = 08 (hex)
 Subfunction Hi = 00 (hex)
 Subfunction Lo = 04 (hex)
 Data Hi = xx (don't care)
 Data Lo = xx (don't care)
 CRC Hi error check
 CRC Lo error check

Preset Multiple Registers

A preset multiple registers query could address multiple registers in one slave or multiple slaves. If the query is a broadcast (device address = 0), no response message is returned.

Query

A Preset Multiple Register query message requests a register or block of registers to be written. The data block contains the starting address and the quantity of registers to be written, followed by the Data Block byte count and data. The DECS-150 will perform the write when the device address in query is a broadcast address or the same as the DECS-150 Modbus Unit ID (device address).

A register address of N will write Holding Register N+1.

Data will cease to be written if any of the following exceptions occur.

- Queries to write to Read Only registers result in an error response with Exception Code of "Illegal Data Address".
- Queries attempting to write more than 100 registers cause an error response with Exception Code "Illegal Function".
- An incorrect Byte Count will result in an error response with Exception Code of "Illegal Data Value".
- There are several instances of registers that are grouped together to collectively represent a single numerical DECS-150 data value (i.e. - floating point data, 32-bit integer data, and strings). A query to write a subset of such a register group will result in an error response with Exception Code "Illegal Data Address".
- A query to write a not allowed value (out of range) to a register results in an error response with Exception Code of "Illegal Data Value".

Device Address
 Function Code = 10 (hex)
 Starting Address Hi
 Starting Address Lo
 No. of Registers Hi
 No. of Registers Lo
 Byte Count
 Data Hi
 Data Lo
 .
 .
 Data Hi
 Data Lo
 CRC Hi error check
 CRC Lo error check

Response

The response message echoes the starting address and the number of registers. There is no response message when the query is a broadcast (device address = 0).

Device Address
 Function Code = 10 (hex)
 Starting Address Hi
 Starting Address Lo
 No. of Registers Hi
 No. of Registers Lo
 CRC Hi Error Check
 CRC Lo Error Check

Preset Single Register

A Preset Single Register query message requests a single register to be written. If the query is a broadcast (device address = 0), no response message is returned.

Note: Only data types INT16, INT8, UINT16, UINT8, and String (not longer than 2 bytes), can be preset by this function.

Query

Data will cease to be written if any of the following exceptions occur.

- Queries to write to Read Only registers result in an error response with Exception Code of “Illegal Data Address”.
- A query to write an unallowed value (out of range) to a register results in an error response with Exception Code of “Illegal Data Value”.

Device Address
 Function Code = 06 (hex)
 Address Hi
 Address Lo
 Data Hi
 Data Lo
 CRC Hi error check
 CRC Lo error check

Response

The response message echoes the Query message after the register has been altered.

Data Formats

DECS-150 systems support the following data types:

- Data types mapped to 2 registers
 - Unsigned Integer 32 (Uint32)
 - Floating Point (Float)
 - Strings maximum 4 characters long (String)
- Data types mapped to 1 register
 - Unsigned Integer 16 (Uint16)
 - Unsigned Integer 8 (Uint8)
 - Strings maximum 2 characters long (String)
- Data types mapped to more than 2 registers
 - Strings longer than 4 characters (String)

Floating Point Data Format (Float)

The Modbus floating point data format uses two consecutive holding registers to represent a data value. The first register contains the low-order 16 bits of the following 32-bit format:

- MSB is the sign bit for the floating-point value (0 = positive).

- The next 8 bits are the exponent biased by 127 decimal.
- The 23 LSBs comprise the normalized mantissa. The most-significant bit of the mantissa is always assumed to be 1 and is not explicitly stored, yielding an effective precision of 24 bits.

The value of the floating-point number is obtained by multiplying the binary mantissa times two raised to the power of the unbiased exponent. The assumed bit of the binary mantissa has the value of 1.0, with the remaining 23 bits providing a fractional value. Table 25-3 shows the floating-point format.

Table 25-3. Floating Point Format

Sign	Exponent + 127	Mantissa
1 Bit	8 Bits	23 Bits

The floating-point format allows for values ranging from approximately 8.43×10^{-37} to 3.38×10^{38} . A floating-point value of all zeroes is the value zero. A floating-point value of all ones (not a number) signifies a value currently not applicable or disabled.

Example: The value 95,800 represented in floating-point format is hexadecimal 47BB1C00. This number will read from two consecutive holding registers as follows:

Holding Register	Value
K (Hi Byte)	hex 1C
K (Lo Byte)	hex 00
K+1(Hi Byte)	hex 47
K+1(Lo Byte)	hex BB

The same byte alignments are required to write.

Long Integer Data Format (Uint32)

The Modbus long integer data format uses two consecutive holding registers to represent a 32-bit data value. The first register contains the low-order 16 bits and the second register contains the high-order 16 bits.

Example: The value 95,800 represented in long integer format is hexadecimal 0x00017638. This number will read from two consecutive holding registers as follows:

Holding Register	Value
K (Hi Byte)	hex 76
K (Lo Byte)	hex 38
K+1(Hi Byte)	hex 00
K+1(Lo Byte)	hex 01

The same byte alignments are required to write.

Integer Data Format (Uint16) or Bit-Mapped Variables in Uint16 Format

The Modbus integer data format uses a single holding register to represent a 16-bit data value.

Example: The value 4660 represented in integer format is hexadecimal 0x1234. This number will read from a holding register as follows:

Holding Register	Value
K (Hi Byte)	hex 12
K (Lo Byte)	hex 34

The same byte alignments are required to write.

The Uint16 Data Format is listed in *Binary Points* (Table 25-6), below.

Example: Register 900 occupies 16 rows in the Register Table where each row gives the name of specific bit-mapped data such as 900-0 indicates bit 0 of register 900 is mapped to RF-TRIG.

Short Integer Data Format/Byte Character Data Format (Uint8)

The Modbus short integer data format uses a single holding register to represent an 8-bit data value. The holding register high byte will always be zero.

Example: The value 132 represented in short integer format is hexadecimal 0x84. This number will read from a holding register as follows:

Holding Register	Value
K (Hi Byte)	hex 00
K (Lo Byte)	hex 84

The same byte alignments are required to write.

String Data Format (String)

The Modbus string data format uses one or more holding registers to represent a sequence, or string, of character values. If the string contains a single character, the holding register high byte will contain the ASCII character code and the low byte will be zero.

Example: The string "PASSWORD" represented in string format will read as follows:

Holding Register	Value
K (Hi Byte)	'P'
K (Lo Byte)	'A'
K+1(Hi Byte)	'S'
K+1(Lo Byte)	'S'
K+2(Hi Byte)	'W'
K+2(Lo Byte)	'O'
K+3(Hi Byte)	'R'
K+3(Lo Byte)	'D'

Example: If the above string is changed to "P", the new string will read as follows:

Holding Register	Value
K (Hi Byte)	'P'
K (Lo Byte)	hex 00
K+1(Hi Byte)	hex 00
K+1(Lo Byte)	hex 00
K+2(Hi Byte)	hex 00
K+2(Lo Byte)	hex 00
K+3(Hi Byte)	hex 00
K+3(Lo Byte)	hex 00

The same byte alignments are required to write.

CRC Error Check

This field contains a two-byte CRC value for transmission error detection. The master first calculates the CRC and appends it to the query message. The DECS-150 system recalculates the CRC value for the received query and performs a comparison to the query CRC value to determine if a transmission error has occurred. If so, no response message is generated. If no transmission error has occurred, the slave calculates a new CRC value for the response message and appends it to the message for transmission.

The CRC calculation is performed using all bytes of the device address, function code, and data block fields. A 16-bit CRC-register is initialized to all 1's. Then each eight-bit byte of the message is used in the following algorithm:

First, exclusive-OR the message byte with the low-order byte of the CRC-register. The result, stored in the CRC-register, will then be right-shifted eight times. The CRC-register MSB is zero-filled with each shift. After each shift, the CRC-register LSB is examined. If the LSB is a 1, the CRC-register is exclusive-ORed with the fixed polynomial value A001 (hex) prior to the next shift. Once all bytes of the

message have undergone the above algorithm, the CRC-register will contain the message CRC value to be placed in the error check field.

Secure DECS-150 Login via Modbus

To login to the DECS-150 via Modbus, write the string *username|password* to the Secure Login register (500). Substitute “username” with the user name of the desired access level, include the pipe “|” symbol, and substitute “password” with the password of the chosen access level. To view the current access level, read the Current Access register (520). Write any value to the Logout register (517) to log out of the DECS-150. Upon disconnecting from Modbus over TCP/IP, the user is automatically logged out of the DECS-150.

Modbus Parameters

General

General parameters are listed in Table 25-4.

Table 25-4. General Group Parameters

Group	Name	Register	Type	Bytes	R/W	Unit	Range
System Data	Model Number	1	String	64	R	n/a	0–64
System Data	Firmware Part Number	33	String	64	R	n/a	0–64
Time	Date	97	String	16	R	n/a	0–16
Time	Time	105	String	16	R	n/a	0–16
Unit Information	Style Number	113	String	32	R	n/a	0–32
Unit Information	Serial Number	129	String	32	R	n/a	0–32
Configurable Element 1	Contact Recognition	147	Uint32	4	R W	n/a	Always=0 Alarm=1
Configurable Element 1	Alarm Configuration	149	Uint32	4	R W	n/a	Status Only=0 Alarm=1
Configurable Element 1	Activation Delay	151	Uint32	4	R W	Second	0–300
Configurable Element 2	Contact Recognition	153	Uint32	4	R W	n/a	Always=0 Alarm=1
Configurable Element 2	Alarm Configuration	155	Uint32	4	R W	n/a	Status Only=0 Alarm=1
Configurable Element 2	Activation Delay	157	Uint32	4	R W	Second	0–300
Configurable Element 3	Contact Recognition	159	Uint32	4	R W	n/a	Always=0 Alarm=1
Configurable Element 3	Alarm Configuration	161	Uint32	4	R W	n/a	Status Only=0 Alarm=1
Configurable Element 3	Activation Delay	163	Uint32	4	R W	Second	0–300
Configurable Element 4	Contact Recognition	165	Uint32	4	R W	n/a	Always=0 Alarm=1
Configurable Element 4	Alarm Configuration	167	Uint32	4	R W	n/a	Status Only=0 Alarm=1
Configurable Element 4	Activation Delay	169	Uint32	4	R W	Second	0–300
Configurable Element 5	Contact Recognition	171	Uint32	4	R W	n/a	Always=0 Alarm=1
Configurable Element 5	Alarm Configuration	173	Uint32	4	R W	n/a	Status Only=0 Alarm=1
Configurable Element 5	Activation Delay	175	Uint32	4	R W	Second	0–300
Configurable Element 6	Contact Recognition	177	Uint32	4	R W	n/a	Always=0 Alarm=1
Configurable Element 6	Alarm Configuration	179	Uint32	4	R W	n/a	Status Only=0 Alarm=1
Configurable Element 6	Activation Delay	181	Uint32	4	R W	Second	0–300
Configurable Element 7	Contact Recognition	183	Uint32	4	R W	n/a	Always=0 Alarm=1

Group	Name	Register	Type	Bytes	R/W	Unit	Range
Configurable Element 7	Alarm Configuration	185	Uint32	4	R W	n/a	Status Only=0 Alarm=1
Configurable Element 7	Activation Delay	187	Uint32	4	R W	Second	0-300
Configurable Element 8	Contact Recognition	189	Uint32	4	R W	n/a	Always=0 Alarm=1
Configurable Element 8	Alarm Configuration	191	Uint32	4	R W	n/a	Status Only=0 Alarm=1
Configurable Element 8	Activation Delay	193	Uint32	4	R W	Second	0-300

Security

Table 25-5. Security Group Parameters

Group	Name	Register	Type	Bytes	R/W	Range
Security	Secure Login	500	String	34	RW	0-34
Security	Logout	517	String	5	RW	0-5
Security	Current Access	520	Uint32	4	R	No Access=0 Read Access=1 Control Access=2 Operator Access=3 Setting Access=4 Design Access=5 Administrator Access=6
Security	Save Changes	522	Uint32	4	R W	n/a

Binary Points

Table 25-6. Binary Point Group Parameters

Group	Name	Register	Type	Bytes	R/W	Range
Alarms	Firmware Change Alarm	900 bit 0	Uint16	2	R	True=1 False=0
Alarms	Ethernet Link Lost Alarm	900 bit 1	Uint16	2	R	True=1 False=0
Alarms	Logic Equal None Alarm	900 bit 2	Uint16	2	R	True=1 False=0
Alarms	Programmable Alarm 1	900 bit 3	Uint16	2	R	True=1 False=0
Alarms	Programmable Alarm 2	900 bit 4	Uint16	2	R	True=1 False=0
Alarms	Programmable Alarm 3	900 bit 5	Uint16	2	R	True=1 False=0
Alarms	Programmable Alarm 4	900 bit 6	Uint16	2	R	True=1 False=0
Alarms	Programmable Alarm 5	900 bit 7	Uint16	2	R	True=1 False=0
Alarms	Programmable Alarm 6	900 bit 8	Uint16	2	R	True=1 False=0
Alarms	Programmable Alarm 7	900 bit 9	Uint16	2	R	True=1 False=0
Alarms	Programmable Alarm 8	900 bit 10	Uint16	2	R	True=1 False=0
Alarms	Programmable Alarm 9	900 bit 11	Uint16	2	R	True=1 False=0
Alarms	Programmable Alarm 10	900 bit 12	Uint16	2	R	True=1 False=0
Alarms	Programmable Alarm 11	900 bit 13	Uint16	2	R	True=1 False=0
Alarms	Programmable Alarm 12	900 bit 14	Uint16	2	R	True=1 False=0
Alarms	Programmable Alarm 13	900 bit 15	Uint16	2	R	True=1 False=0
Alarms	Programmable Alarm 14	901 bit 0	Uint16	2	R	True=1 False=0
Alarms	Programmable Alarm 15	901 bit 1	Uint16	2	R	True=1 False=0
Alarms	Programmable Alarm 16	901 bit 2	Uint16	2	R	True=1 False=0
Alarms	Underfrequency V/Hz Alarm	901 bit 3	Uint16	2	R	True=1 False=0
Alarms	OEL Alarm	901 bit 4	Uint16	2	R	True=1 False=0
Alarms	UEL Alarm	901 bit 5	Uint16	2	R	True=1 False=0
Alarms	SCL Alarm	901 bit 6	Uint16	2	R	True=1 False=0
Alarms	Power Supply Low Alarm	901 bit 7	Uint16	2	R	True=1 False=0
Alarms	PSS Voltage Unbalanced Alarm	901 bit 8	Uint16	2	R	True=1 False=0
Alarms	PSS Current Unbalanced Alarm	901 bit 9	Uint16	2	R	True=1 False=0
Alarms	PSS Power Below Threshold Alarm	901 bit 10	Uint16	2	R	True=1 False=0
Alarms	PSS Speed Failed Alarm	901 bit 11	Uint16	2	R	True=1 False=0

Group	Name	Register	Type	Bytes	R/W	Range
Alarms	PSS Voltage Limit Alarm	901 bit 12	Uint16	2	R	True=1 False=0
Alarms	VM Active	901 bit 13	Uint16	2	R	True=1 False=0
Alarms	Phase Rotation Mismatch	901 bit 14	Uint16	2	R	True=1 False=0
Alarm Report	Alarm Output	901 bit 15	Uint16	2	R	True=1 False=0
Contact Inputs	Input 1	902 bit 0	Uint16	2	R	True=1 False=0
Contact Inputs	Input 2	902 bit 1	Uint16	2	R	True=1 False=0
Contact Inputs	Input 3	902 bit 2	Uint16	2	R	True=1 False=0
Contact Inputs	Input 4	902 bit 3	Uint16	2	R	True=1 False=0
Contact Inputs	Input 5	902 bit 4	Uint16	2	R	True=1 False=0
Contact Inputs	Input 6	902 bit 5	Uint16	2	R	True=1 False=0
Contact Inputs	Input 7	902 bit 6	Uint16	2	R	True=1 False=0
Contact Inputs	Input 8	902 bit 7	Uint16	2	R	True=1 False=0
Contact Outputs	Watchdog Output	902 bit 8	Uint16	2	R	True=1 False=0
Contact Outputs	Output 1	902 bit 9	Uint16	2	R	True=1 False=0
Contact Outputs	Output 2	902 bit 10	Uint16	2	R	True=1 False=0
Contact Outputs	Breaker Shunt Trip Output	902 bit 11	Uint16	2	R	True=1 False=0
Hardware Ports	Field Short Circuit Status	902 bit 12	Uint16	2	R	True=1 False=0
Virtual Switch	Virtual Switch 1	902 bit 13	Uint16	2	R	True=1 False=0
Virtual Switch	Virtual Switch 2	902 bit 14	Uint16	2	R	True=1 False=0
Virtual Switch	Virtual Switch 3	902 bit 15	Uint16	2	R	True=1 False=0
Virtual Switch	Virtual Switch 4	903 bit 0	Uint16	2	R	True=1 False=0
Virtual Switch	Virtual Switch 5	903 bit 1	Uint16	2	R	True=1 False=0
Virtual Switch	Virtual Switch 6	903 bit 2	Uint16	2	R	True=1 False=0
DECS Control	Internal Tracking Disable	903 bit 3	Uint16	2	R	True=1 False=0
DECS Control	External Tracking Disable	903 bit 4	Uint16	2	R	True=1 False=0
DECS Control	OEL Online	903 bit 5	Uint16	2	R	True=1 False=0
DECS Control	Droop Disable	903 bit 6	Uint16	2	R	True=1 False=0
DECS Control	CC Disable	903 bit 7	Uint16	2	R	True=1 False=0
DECS Control	Line Drop Disable	903 bit 8	Uint16	2	R	True=1 False=0
DECS Control	Voltage Matching Disable	903 bit 9	Uint16	2	R	True=1 False=0
DECS Control	PF Var Enable JK	903 bit 10	Uint16	2	R	True=1 False=0
DECS Control	Loss of Transfer Disable	903 bit 11	Uint16	2	R	True=1 False=0
DECS Control	Parallel Enable LM	903 bit 12	Uint16	2	R	True=1 False=0
DECS Control	Soft Start Select Group 2	903 bit 13	Uint16	2	R	True=1 False=0
DECS Control	PSS Select Group 2	903 bit 14	Uint16	2	R	True=1 False=0
DECS Control	OEL Select Group 2	903 bit 15	Uint16	2	R	True=1 False=0
DECS Control	UEL Select Group 2	904 bit 0	Uint16	2	R	True=1 False=0
DECS Control	SCL Select Group 2	904 bit 1	Uint16	2	R	True=1 False=0
DECS Control	Protect Select Group 2	904 bit 2	Uint16	2	R	True=1 False=0
DECS Control	PID Select Group 2	904 bit 3	Uint16	2	R	True=1 False=0
DECS Control	Var PF Selection	904 bit 4	Uint16	2	R	True=1 False=0
DECS Control	DECS Start/Stop External	904 bit 5	Uint16	2	R	True=1 False=0
DECS Control	DECS Manual/Auto	904 bit 6	Uint16	2	R	True=1 False=0
DECS Control	DECS Preposition	904 bit 7	Uint16	2	R	True=1 False=0
DECS Control	Softstart Active	904 bit 8	Uint16	2	R	True=1 False=0
Reserved		904 bit 9				
DECS Control	Preposition 1 Active	904 bit 10	Uint16	2	R	True=1 False=0
DECS Control	Preposition 2 Active	904 bit 11	Uint16	2	R	True=1 False=0
DECS Control	Preposition 3 Active	904 bit 12	Uint16	2	R	True=1 False=0
DECS Control	Var Active	904 bit 13	Uint16	2	R	True=1 False=0
DECS Control	PF Active	904 bit 14	Uint16	2	R	True=1 False=0

Group	Name	Register	Type	Bytes	R/W	Range
DECS Control	Manual Active	904 bit 15	Uint16	2	R	True=1 False=0
DECS Control	Auto Active	905 bit 0	Uint16	2	R	True=1 False=0
DECS PSS Meter	PSS Active	905 bit 1	Uint16	2	R	True=1 False=0
DECS Regulator Meter	Setpoint at Lower Limit	905 bit 2	Uint16	2	R	True=1 False=0
DECS Regulator Meter	Setpoint at Upper Limit	905 bit 3	Uint16	2	R	True=1 False=0
DECS Regulator Meter	Internal Tracking Active	905 bit 4	Uint16	2	R	True=1 False=0
DECS Regulator Meter	External Tracking Active	905 bit 5	Uint16	2	R	True=1 False=0
Field Overvoltage	Pickup	905 bit 6	Uint16	2	R	True=1 False=0
Field Overvoltage	Trip	905 bit 7	Uint16	2	R	True=1 False=0
Loss of Sensing	Pickup	905 bit 8	Uint16	2	R	True=1 False=0
Loss of Sensing	Trip	905 bit 9	Uint16	2	R	True=1 False=0
EDM	Pickup	905 bit 10	Uint16	2	R	True=1 False=0
EDM	Trip	905 bit 11	Uint16	2	R	True=1 False=0
25 Element	Status	905 bit 12	Uint16	2	R	True=1 False=0
27P Element	Block	905 bit 13	Uint16	2	R	True=1 False=0
27P Element	Pickup	905 bit 14	Uint16	2	R	True=1 False=0
27P Element	Trip	905 bit 15	Uint16	2	R	True=1 False=0
59P Element	Pickup	906 bit 0	Uint16	2	R	True=1 False=0
59P Element	Trip	906 bit 1	Uint16	2	R	True=1 False=0
81-1 Element	Pickup	906 bit 2	Uint16	2	R	True=1 False=0
81-1 Element	Trip	906 bit 3	Uint16	2	R	True=1 False=0
81-2 Element	Pickup	906 bit 4	Uint16	2	R	True=1 False=0
81-2 Element	Trip	906 bit 5	Uint16	2	R	True=1 False=0
Gen Below 10 Hz	Pickup	906 bit 6	Uint16	2	R	True=1 False=0
Gen Below 10 Hz	Trip	906 bit 7	Uint16	2	R	True=1 False=0
Configurable Protection 1	Configurable Protection Threshold 1 Pickup	906 bit 8	Uint16	2	R	True=1 False=0
Configurable Protection 1	Configurable Protection Threshold 1 Trip	906 bit 9	Uint16	2	R	True=1 False=0
Configurable Protection 1	Configurable Protection Threshold 2 Pickup	906 bit 10	Uint16	2	R	True=1 False=0
Configurable Protection 1	Configurable Protection Threshold 2 Trip	906 bit 11	Uint16	2	R	True=1 False=0
Configurable Protection 1	Configurable Protection Threshold 3 Pickup	906 bit 12	Uint16	2	R	True=1 False=0
Configurable Protection 1	Configurable Protection Threshold 3 Trip	906 bit 13	Uint16	2	R	True=1 False=0
Configurable Protection 1	Configurable Protection Threshold 4 Pickup	906 bit 14	Uint16	2	R	True=1 False=0
Configurable Protection 1	Configurable Protection Threshold 4 Trip	906 bit 15	Uint16	2	R	True=1 False=0
Configurable Protection 2	Configurable Protection Threshold 1 Pickup	907 bit 0	Uint16	2	R	True=1 False=0
Configurable Protection 2	Configurable Protection Threshold 1 Trip	907 bit 1	Uint16	2	R	True=1 False=0
Configurable Protection 2	Configurable Protection Threshold 2 Pickup	907 bit 2	Uint16	2	R	True=1 False=0
Configurable Protection 2	Configurable Protection Threshold 2 Trip	907 bit 3	Uint16	2	R	True=1 False=0
Configurable Protection 2	Configurable Protection Threshold 3 Pickup	907 bit 4	Uint16	2	R	True=1 False=0
Configurable Protection 2	Configurable Protection Threshold 3 Trip	907 bit 5	Uint16	2	R	True=1 False=0
Configurable Protection 2	Configurable Protection Threshold 4 Pickup	907 bit 6	Uint16	2	R	True=1 False=0
Configurable Protection 2	Configurable Protection Threshold 4 Trip	907 bit 7	Uint16	2	R	True=1 False=0
Configurable Protection 3	Configurable Protection Threshold 1 Pickup	907 bit 8	Uint16	2	R	True=1 False=0
Configurable Protection 3	Configurable Protection Threshold 1 Trip	907 bit 9	Uint16	2	R	True=1 False=0
Configurable Protection 3	Configurable Protection Threshold 2 Pickup	907 bit 10	Uint16	2	R	True=1 False=0
Configurable Protection 3	Configurable Protection Threshold 2 Trip	907 bit 11	Uint16	2	R	True=1 False=0
Configurable Protection 3	Configurable Protection Threshold 3 Pickup	907 bit 12	Uint16	2	R	True=1 False=0
Configurable Protection 3	Configurable Protection Threshold 3 Trip	907 bit 13	Uint16	2	R	True=1 False=0
Configurable Protection 3	Configurable Protection Threshold 4 Pickup	907 bit 14	Uint16	2	R	True=1 False=0
Configurable Protection 3	Configurable Protection Threshold 4 Trip	907 bit 15	Uint16	2	R	True=1 False=0
Configurable Protection 4	Configurable Protection Threshold 1 Pickup	908 bit 0	Uint16	2	R	True=1 False=0
Configurable Protection 4	Configurable Protection Threshold 1 Trip	908 bit 1	Uint16	2	R	True=1 False=0

Group	Name	Register	Type	Bytes	R/W	Range
Configurable Protection 4	Configurable Protection Threshold 2 Pickup	908 bit 2	Uint16	2	R	True=1 False=0
Configurable Protection 4	Configurable Protection Threshold 2 Trip	908 bit 3	Uint16	2	R	True=1 False=0
Configurable Protection 4	Configurable Protection Threshold 3 Pickup	908 bit 4	Uint16	2	R	True=1 False=0
Configurable Protection 4	Configurable Protection Threshold 3 Trip	908 bit 5	Uint16	2	R	True=1 False=0
Configurable Protection 4	Configurable Protection Threshold 4 Pickup	908 bit 6	Uint16	2	R	True=1 False=0
Configurable Protection 4	Configurable Protection Threshold 4 Trip	908 bit 7	Uint16	2	R	True=1 False=0
Configurable Protection 5	Configurable Protection Threshold 1 Pickup	908 bit 8	Uint16	2	R	True=1 False=0
Configurable Protection 5	Configurable Protection Threshold 1 Trip	908 bit 9	Uint16	2	R	True=1 False=0
Configurable Protection 5	Configurable Protection Threshold 2 Pickup	908 bit 10	Uint16	2	R	True=1 False=0
Configurable Protection 5	Configurable Protection Threshold 2 Trip	908 bit 11	Uint16	2	R	True=1 False=0
Configurable Protection 5	Configurable Protection Threshold 3 Pickup	908 bit 12	Uint16	2	R	True=1 False=0
Configurable Protection 5	Configurable Protection Threshold 3 Trip	908 bit 13	Uint16	2	R	True=1 False=0
Configurable Protection 5	Configurable Protection Threshold 4 Pickup	908 bit 14	Uint16	2	R	True=1 False=0
Configurable Protection 5	Configurable Protection Threshold 4 Trip	908 bit 15	Uint16	2	R	True=1 False=0
Configurable Protection 6	Configurable Protection Threshold 1 Pickup	909 bit 0	Uint16	2	R	True=1 False=0
Configurable Protection 6	Configurable Protection Threshold 1 Trip	909 bit 1	Uint16	2	R	True=1 False=0
Configurable Protection 6	Configurable Protection Threshold 2 Pickup	909 bit 2	Uint16	2	R	True=1 False=0
Configurable Protection 6	Configurable Protection Threshold 2 Trip	909 bit 3	Uint16	2	R	True=1 False=0
Configurable Protection 6	Configurable Protection Threshold 3 Pickup	909 bit 4	Uint16	2	R	True=1 False=0
Configurable Protection 6	Configurable Protection Threshold 3 Trip	909 bit 5	Uint16	2	R	True=1 False=0
Configurable Protection 6	Configurable Protection Threshold 4 Pickup	909 bit 6	Uint16	2	R	True=1 False=0
Configurable Protection 6	Configurable Protection Threshold 4 Trip	909 bit 7	Uint16	2	R	True=1 False=0
Configurable Protection 7	Configurable Protection Threshold 1 Pickup	909 bit 8	Uint16	2	R	True=1 False=0
Configurable Protection 7	Configurable Protection Threshold 1 Trip	909 bit 9	Uint16	2	R	True=1 False=0
Configurable Protection 7	Configurable Protection Threshold 2 Pickup	909 bit 10	Uint16	2	R	True=1 False=0
Configurable Protection 7	Configurable Protection Threshold 2 Trip	909 bit 11	Uint16	2	R	True=1 False=0
Configurable Protection 7	Configurable Protection Threshold 3 Pickup	909 bit 12	Uint16	2	R	True=1 False=0
Configurable Protection 7	Configurable Protection Threshold 3 Trip	909 bit 13	Uint16	2	R	True=1 False=0
Configurable Protection 7	Configurable Protection Threshold 4 Pickup	909 bit 14	Uint16	2	R	True=1 False=0
Configurable Protection 7	Configurable Protection Threshold 4 Trip	909 bit 15	Uint16	2	R	True=1 False=0
Configurable Protection 8	Configurable Protection Threshold 1 Pickup	910 bit 0	Uint16	2	R	True=1 False=0
Configurable Protection 8	Configurable Protection Threshold 1 Trip	910 bit 1	Uint16	2	R	True=1 False=0
Configurable Protection 8	Configurable Protection Threshold 2 Pickup	910 bit 2	Uint16	2	R	True=1 False=0
Configurable Protection 8	Configurable Protection Threshold 2 Trip	910 bit 3	Uint16	2	R	True=1 False=0
Configurable Protection 8	Configurable Protection Threshold 3 Pickup	910 bit 4	Uint16	2	R	True=1 False=0
Configurable Protection 8	Configurable Protection Threshold 3 Trip	910 bit 5	Uint16	2	R	True=1 False=0
Configurable Protection 8	Configurable Protection Threshold 4 Pickup	910 bit 6	Uint16	2	R	True=1 False=0
Configurable Protection 8	Configurable Protection Threshold 4 Trip	910 bit 7	Uint16	2	R	True=1 False=0
Network Load Share	Network Load Share Disable	910 bit 8	Uint16	2	R	True=1 False=0
Network Load Share	No Network Load Share Data	910 bit 9	Uint16	2	R	True=1 False=0
Network Load Share	Unknown Load Share Protocol Version	910 bit 10	Uint16	2	R	True=1 False=0
Network Load Share	Receiving ID 1	910 bit 11	Uint16	2	R	True=1 False=0
Network Load Share	Receiving ID 2	910 bit 12	Uint16	2	R	True=1 False=0
Network Load Share	Receiving ID 3	910 bit 13	Uint16	2	R	True=1 False=0
Network Load Share	Receiving ID 4	910 bit 14	Uint16	2	R	True=1 False=0
Network Load Share	Receiving ID 5	910 bit 15	Uint16	2	R	True=1 False=0
Network Load Share	Receiving ID 6	911 bit 0	Uint16	2	R	True=1 False=0
Network Load Share	Receiving ID 7	911 bit 1	Uint16	2	R	True=1 False=0
Network Load Share	Receiving ID 8	911 bit 2	Uint16	2	R	True=1 False=0
Network Load Share	Receiving ID 9	911 bit 3	Uint16	2	R	True=1 False=0
Network Load Share	Receiving ID 10	911 bit 4	Uint16	2	R	True=1 False=0

Group	Name	Register	Type	Bytes	R/W	Range
Network Load Share	Receiving ID 11	911 bit 5	Uint16	2	R	True=1 False=0
Network Load Share	Receiving ID 12	911 bit 6	Uint16	2	R	True=1 False=0
Network Load Share	Receiving ID 13	911 bit 7	Uint16	2	R	True=1 False=0
Network Load Share	Receiving ID 14	911 bit 8	Uint16	2	R	True=1 False=0
Network Load Share	Receiving ID 15	911 bit 9	Uint16	2	R	True=1 False=0
Network Load Share	Receiving ID 16	911 bit 10	Uint16	2	R	True=1 False=0
Network Load Share	NLS Configuration Mismatch	911 bit 11	Uint16	2	R	True=1 False=0
Network Load Share	NLS ID Missing	911 bit 12	Uint16	2	R	True=1 False=0
Network Load Share	NLS Status 1	911 bit 13	Uint16	2	R	True=1 False=0
Network Load Share	NLS Status 2	911 bit 14	Uint16	2	R	True=1 False=0
Network Load Share	NLS Status 3	911 bit 15	Uint16	2	R	True=1 False=0
Network Load Share	NLS Status 4	912 bit 0	Uint16	2	R	True=1 False=0
Reserved		912 bit 1				
Configurable Element 1	Output	912 bit 2	Uint16	2	R	True=1 False=0
Configurable Element 1	Alarm	912 bit 3	Uint16	2	R	True=1 False=0
Configurable Element 2	Output	912 bit 4	Uint16	2	R	True=1 False=0
Configurable Element 2	Alarm	912 bit 5	Uint16	2	R	True=1 False=0
Configurable Element 3	Output	912 bit 6	Uint16	2	R	True=1 False=0
Configurable Element 3	Alarm	912 bit 7	Uint16	2	R	True=1 False=0
Configurable Element 4	Output	912 bit 8	Uint16	2	R	True=1 False=0
Configurable Element 4	Alarm	912 bit 9	Uint16	2	R	True=1 False=0
Configurable Element 5	Output	912 bit 10	Uint16	2	R	True=1 False=0
Configurable Element 5	Alarm	912 bit 11	Uint16	2	R	True=1 False=0
Configurable Element 6	Output	912 bit 12	Uint16	2	R	True=1 False=0
Configurable Element 6	Alarm	912 bit 13	Uint16	2	R	True=1 False=0
Configurable Element 7	Output	912 bit 14	Uint16	2	R	True=1 False=0
Configurable Element 7	Alarm	912 bit 15	Uint16	2	R	True=1 False=0
Configurable Element 8	Output	913 bit 0	Uint16	2	R	True=1 False=0
Configurable Element 8	Alarm	913 bit 1	Uint16	2	R	True=1 False=0
Hardware Shutdown	Hardware Shutdown	913 bit 2	Uint16	2	R	True=1 False=0
Network Load Share	ID 1 Enabled	913 bit 3	Uint16	2	R	True=1 False=0
Network Load Share	ID 2 Enabled	913 bit 4	Uint16	2	R	True=1 False=0
Network Load Share	ID 3 Enabled	913 bit 5	Uint16	2	R	True=1 False=0
Network Load Share	ID 4 Enabled	913 bit 6	Uint16	2	R	True=1 False=0
Network Load Share	ID 5 Enabled	913 bit 7	Uint16	2	R	True=1 False=0
Network Load Share	ID 6 Enabled	913 bit 8	Uint16	2	R	True=1 False=0
Network Load Share	ID 7 Enabled	913 bit 9	Uint16	2	R	True=1 False=0
Network Load Share	ID 8 Enabled	913 bit 10	Uint16	2	R	True=1 False=0
Network Load Share	ID 9 Enabled	913 bit 11	Uint16	2	R	True=1 False=0
Network Load Share	ID 10 Enabled	913 bit 12	Uint16	2	R	True=1 False=0
Network Load Share	ID 11 Enabled	913 bit 13	Uint16	2	R	True=1 False=0
Network Load Share	ID 12 Enabled	913 bit 14	Uint16	2	R	True=1 False=0
Network Load Share	ID 13 Enabled	913 bit 15	Uint16	2	R	True=1 False=0
Network Load Share	ID 14 Enabled	914 bit 0	Uint16	2	R	True=1 False=0
Network Load Share	ID 15 Enabled	914 bit 1	Uint16	2	R	True=1 False=0
Network Load Share	ID 16 Enabled	914 bit 2	Uint16	2	R	True=1 False=0
Grid Code Parameters	LFSM Enable	914 bit 3	Uint16	2	R	True=1 False=0
Grid Code Parameters	LFSM Active	914 bit 4	Uint16	2	R	True=1 False=0
Grid Code Parameters	LVRT Enable	914 bit 5	Uint16	2	R	True=1 False=0
Grid Code Parameters	LVRT Active	914 bit 6	Uint16	2	R	True=1 False=0
Grid Code Parameters	Grid Code Enabled	914 bit 7	Uint16	2	R	True=1 False=0

Group	Name	Register	Type	Bytes	R/W	Range
Grid Code Parameters	APC Enable	914 bit 8	Uint16	2	R	True=1 False=0
Grid Code Parameters	GCC Disconnect Timing	914 bit 9	Uint16	2	R	True=1 False=0
Grid Code Parameters	GCC Disconnect Timed Out	914 bit 10	Uint16	2	R	True=1 False=0
Grid Code Parameters	LVRT Remote Communications Active	914 bit 11	Uint16	2	R	True=1 False=0
Grid Code Parameters	APC Active	914 bit 12	Uint16	2	R	True=1 False=0
Grid Code Parameters	LVRT Remote Communications Fail	914 bit 13	Uint16	2	R	True=1 False=0
Grid Code Parameters	APC Remote Communications Fail	914 bit 14	Uint16	2	R	True=1 False=0
Grid Code Parameters	APC Output Limit	914 bit 15	Uint16	2	R	True=1 False=0
Grid Code Parameters	LFSM Recovery Active	915 bit 0	Uint16	2	R	True=1 False=0
Grid Code Parameters	GCC Disabled	915 bit 1	Uint16	2	R	True=1 False=0
Grid Code Parameters	GCC Continuous Operation	915 bit 2	Uint16	2	R	True=1 False=0
Grid Code Parameters	GCC Frequency Low Timing	915 bit 3	Uint16	2	R	True=1 False=0
Grid Code Parameters	GCC Frequency High Timing	915 bit 4	Uint16	2	R	True=1 False=0
Grid Code Parameters	GCC Volts Low Timing	915 bit 5	Uint16	2	R	True=1 False=0
Grid Code Parameters	GCC Volts High Timing	915 bit 6	Uint16	2	R	True=1 False=0
Grid Code Parameters	GCC Out of Range Timing	915 bit 7	Uint16	2	R	True=1 False=0
Grid Code Parameters	GCC Disconnected	915 bit 8	Uint16	2	R	True=1 False=0
Grid Code Parameters	GCC Reconnect Timing	915 bit 9	Uint16	2	R	True=1 False=0
Grid Code Parameters	LFSM Over Active	915 bit 10	Uint16	2	R	True=1 False=0
Grid Code Parameters	LFSM Under Active	915 bit 11	Uint16	2	R	True=1 False=0
Grid Code Parameters	LFSM Normal Operation	915 bit 12	Uint16	2	R	True=1 False=0
Grid Code Parameters	LVRT Modbus Communications Fail	915 bit 13	Uint16	2	R	True=1 False=0
Reserved		915 bit 14				
Reserved		915 bit 15				
Grid Code Parameters	APC Modbus Communications Fail	916 bit 0	Uint16	2	R	True=1 False=0
Reserved		916 bit 1				
Reserved		916 bit 2				
Grid Code Parameters	APC Remote Communications Active	916 bit 3	Uint16	2	R	True=1 False=0
Grid Code Parameters	Freeze LVRT Output from PLC	916 bit 4	Uint16	2	R	True=1 False=0
Grid Code Parameters	Freeze APC Output from PLC	916 bit 5	Uint16	2	R	True=1 False=0
Grid Code Parameters	APC Bridge Active	916 bit 6	Uint16	2	R	True=1 False=0
Grid Code Parameters	LVRT Bridge Active	916 bit 7	Uint16	2	R	True=1 False=0
Alarms	External Tracking Communications Loss	916 bit 8	Uint16	2	R	True=1 False=0

Metering

Table 25-7. Metering Group Parameters

Group	Name	Register	Type	Bytes	R/W	Unit	Range
Per Unit Meter	Vab	1000	Float	4	R	Per Unit	-10 – 10
Per Unit Meter	Vbc	1002	Float	4	R	Per Unit	-10 – 10
Per Unit Meter	Vca	1004	Float	4	R	Per Unit	-10 – 10
Per Unit Meter	V Average	1006	Float	4	R	Per Unit	-10 – 10
Per Unit Meter	Ia	1008	Float	4	R	Per Unit	-10 – 10
Per Unit Meter	Ib	1010	Float	4	R	Per Unit	-10 – 10
Per Unit Meter	Ic	1012	Float	4	R	Per Unit	-10 – 10
Per Unit Meter	I Average	1014	Float	4	R	Per Unit	-10 – 10
Per Unit Meter	kW	1016	Float	4	R	Per Unit	-10 – 10
Per Unit Meter	kVA	1018	Float	4	R	Per Unit	-10 – 10
Per Unit Meter	Kvar	1020	Float	4	R	Per Unit	-10 – 10
Per Unit Meter	Positive Sequence Voltage	1022	Float	4	R	Per Unit	-10 – 10
Per Unit Meter	Negative Sequence Voltage	1024	Float	4	R	Per Unit	-10 – 10
Per Unit Meter	Positive Sequence Current	1026	Float	4	R	Per Unit	-10 – 10

Group	Name	Register	Type	Bytes	R/W	Unit	Range
Per Unit Meter	Negative Sequence Current	1028	Float	4	R	Per Unit	-10 – 10
Per Unit Meter	Bus Vab	1030	Float	4	R	Per Unit	-10 – 10
Per Unit Meter	Bus Vbc	1032	Float	4	R	Per Unit	-10 – 10
Per Unit Meter	Bus Vca	1034	Float	4	R	Per Unit	-10 – 10
Per Unit Meter	Bus V Average	1036	Float	4	R	Per Unit	-10 – 10
Per Unit Meter	Voltage Difference	1038	Float	4	R	Per Unit	-10 – 10
Per Unit Meter	Power in Voltage	1040	Float	4	R	Per Unit	-10 – 10
Per Unit Meter	Control Out Var PF	1042	Float	4	R	Per Unit	-10 – 10
Per Unit Meter	Control Out OEL	1044	Float	4	R	Per Unit	-10 – 10
Per Unit Meter	Control Out UEL	1046	Float	4	R	Per Unit	-10 – 10
Per Unit Meter	Control Out SCL	1048	Float	4	R	Per Unit	-10 – 10
Per Unit Meter	Control Out AVR	1050	Float	4	R	Per Unit	-10 – 10
Per Unit Meter	Control Out FCR	1052	Float	4	R	Per Unit	-10 – 10
Per Unit Meter	Null Balance Percent	1054	Float	4	R	Per Unit	-10 – 10
Per Unit Meter	Generator Frequency	1056	Float	4	R	Per Unit	-10 – 10
Per Unit Meter	Bus Frequency	1058	Float	4	R	Per Unit	-10 – 10
Per Unit Meter	lfd	1060	Float	4	R	Per Unit	-10 – 10
Per Unit Meter	Vfd	1062	Float	4	R	Per Unit	-10 – 10
Per Unit Meter	Slip Frequency	1064	Float	4	R	Per Unit	-10 – 10
Per Unit Meter	lcc	1066	Float	4	R	Per Unit	-10 – 10
Per Unit Meter	AVR Setpoint	1068	Float	4	R	Per Unit	-10 – 10
Per Unit Meter	FCR Setpoint	1070	Float	4	R	Per Unit	-10 – 10
Per Unit Meter	FVR Setpoint	1072	Float	4	R	Per Unit	-10 – 10
Per Unit Meter	Var Setpoint	1074	Float	4	R	Per Unit	-10 – 10
Field Current Meter	Ix	1076	Float	4	R	Amp	0–2000000000
DECS PSS Meter	Terminal Frequency Deviation	1078	Float	4	R	Percent	n/a
DECS PSS Meter	Compensated Frequency Deviation	1080	Float	4	R	Percent	n/a
DECS PSS Meter	PSS Output	1082	Float	4	R	n/a	n/a
DECS Regulator Meter	Tracking Error	1084	Float	4	R	Percent	n/a
DECS Regulator Meter	Control Output PU	1086	Float	4	R	Per Unit	-10 – 10
DECS Regulator Meter	Exciter Diode Monitor Ripple	1088	Float	4	R	Amp	0–2000000000
DECS Regulator Meter	Power Input	1090	Float	4	R	Volt	0–2000000000
DECS Regulator Meter	Control Output	1092	Float	4	R	Percent	n/a
DECS Regulator Meter	V1 Phase Angle	1094	Float	4	R	Degree	0–360
Reserved		1096-1106					
Generator Voltage Meter Primary 1	V _{AB}	1108	Float	4	R	Volt	0–2000000000
Generator Voltage Meter Primary 1	V _{BC}	1110	Float	4	R	Volt	0–2000000000
Generator Voltage Meter Primary 1	V _{CA}	1112	Float	4	R	Volt	0–2000000000
Generator Voltage Meter Primary 1	V1 L	1114	Float	4	R	Volt	0–2000000000
Generator Voltage Meter Primary 1	V2 L	1116	Float	4	R	Volt	0–2000000000
Generator Voltage Meter Primary 1	V _{AVG LL}	1118	Float	4	R	Volt	0–2000000000
Generator Voltage Meter Angle 1	V _{AB}	1120	Float	4	R	Degree	0–360
Generator Voltage Meter Angle 1	V _{BC}	1122	Float	4	R	Degree	0–360
Generator Voltage Meter Angle 1	V _{CA}	1124	Float	4	R	Degree	0–360

Group	Name	Register	Type	Bytes	R/W	Unit	Range
Reserved		1126-36					
Bus Voltage Meter Primary 1	V _{AB}	1138	Float	4	R	Volt	0–2000000000
Bus Voltage Meter Primary 1	V _{BC}	1140	Float	4	R	Volt	0–2000000000
Bus Voltage Meter Primary 1	V _{CA}	1142	Float	4	R	Volt	0–2000000000
Bus Voltage Meter Primary 1	V1 L	1144	Float	4	R	Volt	0–2000000000
Bus Voltage Meter Primary 1	V2 L	1146	Float	4	R	Volt	0–2000000000
Bus Voltage Meter Primary 1	V _{AVG LL}	1148	Float	4	R	Volt	0–2000000000
Bus Voltage Meter Angle 1	V _{AB}	1150	Float	4	R	Degree	0–360
Bus Voltage Meter Angle 1	V _{BC}	1152	Float	4	R	Degree	0–360
Bus Voltage Meter Angle 1	V _{CA}	1154	Float	4	R	Degree	0–360
Reserved	I _A	1156-69					
Generator Current Meter Primary 1	I _A	1168	Float	4	R	Amp	0–2000000000
Generator Current Meter Primary 1	I _B	1170	Float	4	R	Amp	0–2000000000
Generator Current Meter Primary 1	I _C	1172	Float	4	R	Amp	0–2000000000
Generator Current Meter Primary 1	I1	1174	Float	4	R	Amp	0–2000000000
Generator Current Meter Primary 1	I2	1176	Float	4	R	Amp	0–2000000000
Generator Current Meter Primary 1	I _{AVG}	1178	Float	4	R	Amp	0–2000000000
Generator Current Meter Angle 1	I _A	1180	Float	4	R	Degree	0–360
Generator Current Meter Angle 1	I _B	1182	Float	4	R	Degree	0–360
Generator Current Meter Angle 1	I _C	1184	Float	4	R	Degree	0–360
Icc Current Meter Magnitude 1	I _X	1186	Float	4	R	Amp	0–2000000000
Icc Current Meter Primary 1	I _X	1188	Float	4	R	Amp	0–2000000000
Power Meter	Total watts primary	1190	Float	4	R	Watt	n/a
Power Meter	Total vars primary	1192	Float	4	R	var	n/a
Power Meter	Total S primary	1194	Float	4	R	VA	n/a
Power Meter	Total PF primary	1196	Float	4	R	PF	-1 – 1
Sync Meter 1	Slip Angle	1198	Float	4	R	Degree	-359.9 – 359.9
Sync Meter 1	Slip Frequency	1200	Float	4	R	Hertz	n/a
Sync Meter 1	Voltage Difference	1202	Float	4	R	Volt	n/a
Generator Frequency Meter 1	Frequency	1204	Float	4	R	Hertz	10–180
Bus Frequency Meter 1	Frequency	1206	Float	4	R	Hertz	10–180
Auxiliary Input Voltage 1	Value	1208	Float	4	R	Volt	-9999999 – 9999999
Auxiliary Input Current 1	Value	1210	Float	4	R	Amp	-9999999 – 9999999
Energy Meter	Positive watthour total	1212	Float	4	RW	Watthour	0.00E+00 – 1.00E+09
Energy Meter	Positive varhour total	1214	Float	4	RW	Varhour	0.00E+00 – 1.00E+09
Energy Meter	Negative watthour total	1216	Float	4	RW	Watthour	-1.00E+09 – 0.00E+00
Energy Meter	Negative varhour total	1218	Float	4	RW	Varhour	-1.00E+09 – 0.00E+00
Energy Meter	VA hour total	1220	Float	4	RW	Varhour	0.00E+00 – 1.00E+09
DECS Regulator Meter	NLS Error Percent	1222	Float	4	R	Percent	n/a
DECS Regulator Meter	Current Magnitude Pickup	1224	Float	4	R	Per Unit	-10 – 10

Group	Name	Register	Type	Bytes	R/W	Unit	Range
DECS Regulator Meter	NLS Current Magnitude Average Pickup	1226	Float	4	R	Per Unit	-10 – 10
DECS Regulator Meter	NLS Number of Generators Online	1228	Int32	4	R	n/a	n/a
Field Voltage Meter	Vx	1230	Float	4	R	Volt	-1000 – 1000
Grid Code	Q Reference	1232	Float	4	R	Per Unit	-10 – 10
Grid Code	P Reference	1234	Float	4	R	Per Unit	-10 – 10
Grid Code	State	1236	Uint32	4	R	n/a	Inactive=0 Active=1
Grid Code	Grid Connect State	1238	Uint32	4	R	n/a	Disabled=0 GCC Continuous Operation=1 GCC Frequency Low Timing=2 GCC Frequency High Timing=3 GCC Voltage Low Timing=4 GCC Voltage High Timing=5 GCC Out of Range Timing=6 GCC Disconnected=7 GCC Timing for Reconnect=8
Grid Code	Grid Disconnect Flag	1240	Int32	4	R	n/a	n/a
Grid Code	LVRT Mode	1242	Uint32	4	R	n/a	Disabled=0 Q(PF)=1 Q(Voltage Limit)=2 Q(U)=3 Q(P)=4 Q(Third Party)=5 Freeze Output=6
Grid Code	LFSM Mode	1244	Uint32	4	R	n/a	Initialize=0 Nominal=1 Underfrequency=2 Overfrequency=3 Recovery=4
Grid Code	Remote LVRT Status	1246	Uint32	4	R	n/a	Disabled=0 Active=1 Failed=2
Grid Code	Remote LFSM Status	1248	Uint32	4	R	n/a	Disabled=0 Active=1 Failed=2
Grid Code	PF Mode Reference	1250	Float	4	R	n/a	n/a
Grid Code	Q U Mode Reference	1252	Float	4	R	Per Unit	-10 – 10
Grid Code	Q Voltage Limit Mode Reference	1254	Float	4	R	Per Unit	-10 – 10
Grid Code	Q Third Party Mode Reference	1256	Float	4	R	Per Unit	-10 – 10
Grid Code	APC Reference	1258	Float	4	R	Per Unit	-10 – 10
Grid Code	LVRT Modbus Comm Fail Timer	1260	Float	4	R	Second	0–600
Reserved		1262					
Grid Code	APC Modbus Comm Fail Timer	1264	Float	4	R	Second	0–600
Reserved		1266					
Grid Code	APC Integrator State	1268	Float	4	R	Per Unit	-10 – 10
Grid Code	APC Error	1270	Float	4	R	Per Unit	-10 – 10
Grid Code	APC P Desired	1272	Float	4	R	Per Unit	-10 – 10
Grid Code	APC Bias Voltage	1274	Float	4	R	n/a	n/a
Grid Code	LVRT Q Desired	1276	Float	4	R	Per Unit	-10 – 10
Grid Code	LVRT Bias Voltage	1278	Float	4	R	n/a	n/a
Grid Code	Test Signal	1280	Float	4	R	n/a	n/a
Reserved		1282					
Reserved		1284					

Group	Name	Register	Type	Bytes	R/W	Unit	Range
Reserved		1286					
Reserved		1288					
Reserved		1290					
Grid Code	Active Power Adjust Modbus	1292	Float	4	R	Per Unit	-10 – 10
Grid Code	PF Reference Adjust Modbus	1294	Float	4	R	n/a	n/a
Grid Code	Q Voltage Limit Adjust Modbus	1296	Float	4	R	Per Unit	-10 – 10
Grid Code	Q U Voltage Bus for Zero Q Adjust Modbus	1298	Float	4	R	Per Unit	-10 – 10
Grid Code	Q Third Party Adjust Modbus	1300	Float	4	R	Per Unit	-10 – 10
Grid Code	APC Mode	1302	Uint32	4	R	n/a	Inactive=0 Active=1 LFSM Override=2
Grid Code	Grid Connect Voltage Timer	1304	Float	4	R	Second	0–2000
Grid Code	Grid Connect Frequency Timer	1306	Float	4	R	Second	0–2000
Grid Code	Grid Connect Disconnect Timer	1308	Float	4	R	Second	0–2000
Grid Code	Grid Connect Reconnect Timer	1310	Float	4	R	Second	0–2000

Limiters

Table 25-8. Limiter Group Parameters

Name	Register	Type	Bytes	R/W	Unit	Range
OEL Primary Current Hi	1700	Float	4	R W	Amp	0–11
OEL Primary Current Mid	1702	Float	4	R W	Amp	0–9
OEL Primary Current Lo	1704	Float	4	R W	Amp	0–7
OEL Primary Time Hi	1706	Float	4	R W	Second	0–10
OEL Primary Time Mid	1708	Float	4	R W	Second	0–120
OEL Primary Current Hi Off	1710	Float	4	R W	Amp	0–11
OEL Primary Current Lo Off	1712	Float	4	R W	Amp	0–7
OEL Primary Current Time Off	1714	Float	4	R W	Second	0–10
OEL Primary Takeover Current Max Off	1716	Float	4	R W	Amp	0–11
OEL Primary Takeover Current Min Off	1718	Float	4	R W	Amp	0–7
OEL Primary Takeover Time Dial Off	1720	Float	4	R W	n/a	0.1–20
OEL Primary Takeover Current Max On	1722	Float	4	R W	Amp	0–11
OEL Primary Takeover Current Min On	1724	Float	4	R W	Amp	0–7
OEL Primary Takeover Time Dial On	1726	Float	4	R W	n/a	0.1–20
OEL Primary Dvdt Enable	1728	Uint32	4	R W	n/a	Disabled=0 Enabled=1
OEL Primary Dvdt Ref	1730	Float	4	R W	n/a	-10 – 0
OEL Secondary Current Hi	1732	Float	4	R W	Amp	0–11
OEL Secondary Current Mid	1734	Float	4	R W	Amp	0–9
OEL Secondary Current Lo	1736	Float	4	R W	Amp	0–7
OEL Secondary Time Hi	1738	Float	4	R W	Second	0–10
OEL Secondary Time Mid	1740	Float	4	R W	Second	0–120
OEL Secondary Current Hi Off	1742	Float	4	R W	Amp	0–11
OEL Secondary Current Lo Off	1744	Float	4	R W	Amp	0–7
OEL Secondary Current Time Off	1746	Float	4	R W	Second	0–10
OEL Secondary Takeover Current Max Off	1748	Float	4	R W	Amp	0–11
OEL Secondary Takeover Current Min Off	1750	Float	4	R W	Amp	0–7
OEL Secondary Takeover Time Dial Off	1752	Float	4	R W	n/a	0.1–20
OEL Secondary Takeover Current Max On	1754	Float	4	R W	Amp	0–11
OEL Secondary Takeover Current Min On	1756	Float	4	R W	Amp	0–7
OEL Secondary Takeover Time Dial On	1758	Float	4	R W	n/a	0.1–20
UEL Primary Curve X1	1760	Float	4	R W	kilowatt	0–62
UEL Primary Curve X2	1762	Float	4	R W	kilowatt	0–62

Name	Register	Type	Bytes	R/W	Unit	Range
UEL Primary Curve X3	1764	Float	4	R W	kilowatt	0–62
UEL Primary Curve X4	1766	Float	4	R W	kilowatt	0–62
UEL Primary Curve X5	1768	Float	4	R W	kilowatt	0–62
UEL Primary Curve Y1	1770	Float	4	R W	kilovar	0–62
UEL Primary Curve Y2	1772	Float	4	R W	kilovar	0–62
UEL Primary Curve Y3	1774	Float	4	R W	kilovar	0–62
UEL Primary Curve Y4	1776	Float	4	R W	kilovar	0–62
UEL Primary Curve Y5	1778	Float	4	R W	kilovar	0–62
UEL Primary Power Filter TC	1780	Float	4	R W	Second	0–20
UEL Primary Voltage Dependent Exponent	1782	Float	4	R W	n/a	0–2
UEL Secondary Curve X1	1784	Float	4	R W	kilowatt	0–62
UEL Secondary Curve X2	1786	Float	4	R W	kilowatt	0–62
UEL Secondary Curve X3	1788	Float	4	R W	kilowatt	0–62
UEL Secondary Curve X4	1790	Float	4	R W	kilowatt	0–62
UEL Secondary Curve X5	1792	Float	4	R W	kilowatt	0–62
UEL Secondary Curve Y1	1794	Float	4	R W	kilovar	0–62
UEL Secondary Curve Y2	1796	Float	4	R W	kilovar	0–62
UEL Secondary Curve Y3	1798	Float	4	R W	kilovar	0–62
UEL Secondary Curve Y4	1800	Float	4	R W	kilovar	0–62
UEL Secondary Curve Y5	1802	Float	4	R W	kilovar	0–62
SCL Primary Reference Hi	1804	Float	4	R W	Amp	0–66000
SCL Primary Reference Lo	1806	Float	4	R W	Amp	0–66000
SCL Primary Time Hi	1808	Float	4	R W	Second	0–60
SCL Primary No Response Time	1810	Float	4	R W	Second	0–10
SCL Secondary Reference Hi	1812	Float	4	R W	Amp	0–66000
SCL Secondary Reference Lo	1814	Float	4	R W	Amp	0–66000
SCL Secondary Time Hi	1816	Float	4	R W	Second	0–60
SCL Secondary No Response Time	1818	Float	4	R W	Second	0–10
OEL Primary Takeover Reset Time Coefficient Off	1820	Float	4	R W	n/a	0.01–100
OEL Primary Takeover Reset Time Coefficient On	1822	Float	4	R W	n/a	0.01–100
OEL Secondary Takeover Reset Time Coefficient Off	1824	Float	4	R W	n/a	0.01–100
OEL Secondary Takeover Reset Time Coefficient On	1826	Float	4	R W	n/a	0.01–100
OEL Primary Takeover Reset Type Off	1828	Uint32	4	R W	n/a	Inverse=0 Integrating=1 Instantaneous=2
OEL Primary Takeover Reset Type On	1830	Uint32	4	R W	n/a	Inverse=0 Integrating=1 Instantaneous=2
OEL Secondary Takeover Reset Type Off	1832	Uint32	4	R W	n/a	Inverse=0 Integrating=1 Instantaneous=2
OEL Secondary Takeover Reset Type On	1834	Uint32	4	R W	n/a	Inverse=0 Integrating=1 Instantaneous=2

Setpoints

Table 25-9. Setpoint Group Parameters

Name	Register	Type	Bytes	R/W	Unit	Range
Field Current Regulation Setpoint	2200	Float	4	R W	Amp	Setpoint adjustment range determined by registers 2212 and 2214.
Field Current Regulation Traverse Rate	2202	Float	4	R W	Second	1–200

Name	Register	Type	Bytes	R/W	Unit	Range
Field Current Regulation Pre-position Mode 1	2204	Uint32	4	R W	n/a	Maintain=0 Release=1
Field Current Regulation Pre-position 1	2206	Float	4	R W	Amp	Setpoint adjustment range determined by registers 2212 and 2214.
Field Current Regulation Pre-position Mode 2	2208	Uint32	4	R W	n/a	Maintain=0 Release=1
Field Current Regulation Pre-position 2	2210	Float	4	R W	Amp	Setpoint adjustment range determined by registers 2212 and 2214.
Field Current Regulation Minimum Setpoint Limit	2212	Float	4	R W	Percent	0–120
Field Current Regulation Maximum Setpoint Limit	2214	Float	4	R W	Percent	0–120
Generator Voltage Setpoint	2216	Float	4	R W	Volt	Setpoint adjustment range determined by registers 2228 and 2230.
Generator Voltage Traverse Rate	2218	Float	4	R W	Second	1–200
Generator Voltage Pre-position Mode 1	2220	Uint32	4	R W	n/a	Maintain=0 Release=1
Generator Voltage Pre-position 1	2222	Float	4	R W	Volt	Setpoint adjustment range determined by registers 2228 and 2230.
Generator Voltage Pre-position Mode 2	2224	Uint32	4	R W	n/a	Maintain=0 Release=1
Generator Voltage Pre-position 2	2226	Float	4	R W	Volt	Setpoint adjustment range determined by registers 2228 and 2230.
Generator Voltage Minimum Setpoint Limit	2228	Float	4	R W	Percent	70–120
Generator Voltage Maximum Setpoint Limit	2230	Float	4	R W	Percent	70–120
Generator var Setpoint	2232	Float	4	R W	kilovar	Setpoint adjustment range determined by registers 2244 and 2246.
Generator var Traverse Rate	2234	Float	4	R W	Second	1–200
Generator var Pre-position Mode 1	2236	Uint32	4	R W	n/a	Maintain=0 Release=1
Generator var Pre-position 1	2238	Float	4	R W	kilovar	Setpoint adjustment range determined by registers 2244 and 2246.
Generator var Pre-position Mode 2	2240	Uint32	4	R W	n/a	Maintain=0 Release=1
Generator var Pre-position 2	2242	Float	4	R W	kilovar	Setpoint adjustment range determined by registers 2244 and 2246.
Generator var Minimum Setpoint Limit	2244	Float	4	R W	Percent	-100 – 100
Generator var Maximum Setpoint Limit	2246	Float	4	R W	Percent	-100 – 100
Generator PF Setpoint	2248	Float	4	R W	Power Factor	Setpoint adjustment range determined by registers 2260 and 2262.
Generator PF Traverse Rate	2250	Float	4	R W	Second	1–200
Generator PF Pre-position Mode 1	2252	Uint32	4	R W	n/a	Maintain=0 Release=1
Generator PF Pre-position 1	2254	Float	4	R W	Power Factor	Setpoint adjustment range determined by registers 2260 and 2262.
Generator PF Pre-position Mode 2	2256	Uint32	4	R W	n/a	Maintain=0 Release=1
Generator PF Pre-position 2	2258	Float	4	R W	Power Factor	Setpoint adjustment range determined by registers 2260 and 2262.
Generator PF Minimum Setpoint Limit	2260	Float	4	R W	Power Factor	0.5–1
Generator PF Maximum Setpoint Limit	2262	Float	4	R W	Power Factor	-1 – -0.5
Droop Value	2264	Float	4	R W	Percent	0–30
L-Drop Value	2266	Float	4	R W	Percent	0–30
Auxiliary Limit Enable	2268	Int32	4	R W	n/a	Disabled=0 Enabled=1
Field Current Regulation Pre-position Mode 3	2270	Uint32	4	R W	n/a	Maintain=0 Release=1
Field Current Regulation Pre-position 3	2272	Float	4	R W	Amp	Setpoint adjustment range determined by registers 2212 and 2214.
Generator Voltage Pre-position Mode 3	2274	Uint32	4	R W	n/a	Maintain=0 Release=1
Generator Voltage Pre-position 3	2276	Float	4	R W	Volt	Setpoint adjustment range determined by registers 2228 and 2230.
Generator var Pre-position Mode 3	2278	Float	4	R W	n/a	Maintain=0 Release=1

Name	Register	Type	Bytes	R/W	Unit	Range
Generator var Pre-position 3	2280	Float	4	R W	kilovar	Setpoint adjustment range determined by registers 2244 and 2246.
Generator PF Pre-position Mode 3	2282	Float	4	R W	n/a	Maintain=0 Release=1
Generator PF Pre-position 3	2284	Float	4	R W	Power Factor	Setpoint adjustment range determined by registers 2260 and 2262.
Active Field Current Regulation Setpoint	2286	Float	4	R W	Amp	Setpoint adjustment range determined by registers 2212 and 2214.
Active Generator Voltage Setpoint	2288	Float	4	R W	Volt	Setpoint adjustment range determined by registers 2228 and 2230. When the With Limit box is checked on the Auxiliary Input screen in BESTCOMSP/us, register 2288 equals register 2216 plus the Aux input. When the With Limit box is not checked on the Auxiliary Input screen in BESTCOMSP/us, register 2288 equals register 2216.
Active Generator var Setpoint	2290	Float	4	R W	kilovar	Setpoint adjustment range determined by registers 2244 and 2246.
Active Generator PF Setpoint	2292	Float	4	R W	Power Factor	Setpoint adjustment range determined by registers 2260 and 2262.
Field Current Preposition Traverse 1	2294	Float	4	R W	Second	0–200
Field Current Preposition Traverse 2	2296	Float	4	R W	Second	0–200
Field Current Preposition Traverse 3	2298	Float	4	R W	Second	0–200
Generator Voltage Preposition Traverse 1	2300	Float	4	R W	Second	0–200
Generator Voltage Preposition Traverse 2	2302	Float	4	R W	Second	0–200
Generator Voltage Preposition Traverse 3	2304	Float	4	R W	Second	0–200
Generator Var Preposition Traverse 1	2306	Float	4	R W	Second	0–200
Generator Var Preposition Traverse 2	2308	Float	4	R W	Second	0–200
Generator Var Preposition Traverse 3	2310	Float	4	R W	Second	0–200
Generator PF Preposition Traverse 1	2312	Float	4	R W	Second	0–200
Generator PF Preposition Traverse 2	2314	Float	4	R W	Second	0–200
Generator PF Preposition Traverse 3	2316	Float	4	R W	Second	0–200

Global Settings

Table 25-10. Global Settings Group Parameters

Group	Name	Register	Type	Bytes	R/W	Unit	Range
PLC Timed Element Settings	Logic Timer 1 Output Timeout	2400	Float	4	R W	Sec	0–1800
PLC Timed Element Settings	Logic Timer 2 Output Timeout	2402	Float	4	R W	Sec	0–1800
PLC Timed Element Settings	Logic Timer 3 Output Timeout	2404	Float	4	R W	Sec	0–1800
PLC Timed Element Settings	Logic Timer 4 Output Timeout	2406	Float	4	R W	Sec	0–1800
PLC Timed Element Settings	Logic Timer 5 Output Timeout	2408	Float	4	R W	Sec	0–1800
PLC Timed Element Settings	Logic Timer 6 Output Timeout	2410	Float	4	R W	Sec	0–1800
PLC Timed Element Settings	Logic Timer 7 Output Timeout	2412	Float	4	R W	Sec	0–1800
PLC Timed Element Settings	Logic Timer 8 Output Timeout	2414	Float	4	R W	Sec	0–1800
PLC Timed Element Settings	Logic Timer 9 Output Timeout	2416	Float	4	R W	Sec	0–1800
PLC Timed Element Settings	Logic Timer 10 Output Timeout	2418	Float	4	R W	Sec	0–1800
PLC Timed Element Settings	Logic Timer 11 Output Timeout	2420	Float	4	R W	Sec	0–1800
PLC Timed Element Settings	Logic Timer 12 Output Timeout	2422	Float	4	R W	Sec	0–1800
PLC Timed Element Settings	Logic Timer 13 Output Timeout	2424	Float	4	R W	Sec	0–1800
PLC Timed Element Settings	Logic Timer 14 Output Timeout	2426	Float	4	R W	Sec	0–1800
PLC Timed Element Settings	Logic Timer 15 Output Timeout	2428	Float	4	R W	Sec	0–1800
PLC Timed Element Settings	Logic Timer 16 Output Timeout	2430	Float	4	R W	Sec	0–1800
PLC Timed Element Settings	Counter 1 Output Timeout	2432	Float	4	R W	n/a	0–1800

Group	Name	Register	Type	Bytes	R/W	Unit	Range
PLC Timed Element Settings	Counter 2 Output Timeout	2434	Float	4	R W	n/a	0-1800
PLC Timed Element Settings	Counter 3 Output Timeout	2436	Float	4	R W	n/a	0-1800
PLC Timed Element Settings	Counter 4 Output Timeout	2438	Float	4	R W	n/a	0-1800
PLC Timed Element Settings	Counter 5 Output Timeout	2440	Float	4	R W	n/a	0-1800
PLC Timed Element Settings	Counter 6 Output Timeout	2442	Float	4	R W	n/a	0-1800
PLC Timed Element Settings	Counter 7 Output Timeout	2444	Float	4	R W	n/a	0-1800
PLC Timed Element Settings	Counter 8 Output Timeout	2446	Float	4	R W	n/a	0-1800
Virtual Switch	Virtual Switch 1 State	2448	Uint32	4	R W	n/a	Open=0 Closed=1
Virtual Switch	Virtual Switch 2 State	2450	Uint32	4	R W	n/a	Open=0 Closed=1
Virtual Switch	Virtual Switch 3 State	2452	Uint32	4	R W	n/a	Open=0 Closed=1
Virtual Switch	Virtual Switch 4 State	2454	Uint32	4	R W	n/a	Open=0 Closed=1
Virtual Switch	Virtual Switch 5 State	2456	Uint32	4	R W	n/a	Open=0 Closed=1
Virtual Switch	Virtual Switch 6 State	2458	Uint32	4	R W	n/a	Open=0 Closed=1
Network Load Share	Load Share Enable	2460	Uint32	4	R W	n/a	Disabled=0 Enabled=1
Network Load Share	Load Share Droop Percent	2462	Float	4	R W	%	0-30
Network Load Share	Load Share Gain	2464	Float	4	R W	n/a	0-1000
Network Load Share	Load Share ID	2466	Uint32	4	R W	n/a	1-16
Network Load Share	Load Sharing ID 1	2468	Uint32	4	R W	n/a	Disabled=0 Enabled=1
Network Load Share	Load Sharing ID 2	2470	Uint32	4	R W	n/a	Disabled=0 Enabled=1
Network Load Share	Load Sharing ID 3	2472	Uint32	4	R W	n/a	Disabled=0 Enabled=1
Network Load Share	Load Sharing ID 4	2474	Uint32	4	R W	n/a	Disabled=0 Enabled=1
Network Load Share	Load Sharing ID 5	2476	Uint32	4	R W	n/a	Disabled=0 Enabled=1
Network Load Share	Load Sharing ID 6	2478	Uint32	4	R W	n/a	Disabled=0 Enabled=1
Network Load Share	Load Sharing ID 7	2480	Uint32	4	R W	n/a	Disabled=0 Enabled=1
Network Load Share	Load Sharing ID 8	2482	Uint32	4	R W	n/a	Disabled=0 Enabled=1
Network Load Share	Load Sharing ID 9	2484	Uint32	4	R W	n/a	Disabled=0 Enabled=1
Network Load Share	Load Sharing ID 10	2486	Uint32	4	R W	n/a	Disabled=0 Enabled=1
Network Load Share	Load Sharing ID 11	2488	Uint32	4	R W	n/a	Disabled=0 Enabled=1
Network Load Share	Load Sharing ID 12	2490	Uint32	4	R W	n/a	Disabled=0 Enabled=1
Network Load Share	Load Sharing ID 13	2492	Uint32	4	R W	n/a	Disabled=0 Enabled=1
Network Load Share	Load Sharing ID 14	2494	Uint32	4	R W	n/a	Disabled=0 Enabled=1
Network Load Share	Load Sharing ID 15	2496	Uint32	4	R W	n/a	Disabled=0 Enabled=1
Network Load Share	Load Sharing ID 16	2498	Uint32	4	R W	n/a	Disabled=0 Enabled=1
Network Load Share	Config Mismatch Delay	2500	Float	4	R W	Second	0.2-10
Reserved		2502-04					
Reactive Cross Current	Load Share Ki Gain	2506	Float	4	R W	n/a	0-1000
Reactive Cross Current	Load Share Max Vc	2508	Float	4	R W	n/a	0-1

Group	Name	Register	Type	Bytes	R/W	Unit	Range
System Configuration	Operating Mode	2510	Int32	4	R W	n/a	Generator=0 Motor=1

Configuration Settings

Table 25-11. Configuration Settings Group Parameters

Group	Name	Register	Type	Bytes	R/W	Unit	Range
System Configuration	Nominal Frequency	2600	Uint32	4	R W	n/a	50 Hz=50 60 Hz=60
System Configuration	Metric English	2602	Uint32	4	R W	n/a	English=0 Metric=1
System Configuration	DECS Auxiliary Summing Mode	2604	Uint32	4	R W	n/a	Voltage=0 Var=1
System Configuration	DECS Auxiliary Input Mode	2606	Uint32	4	R W	n/a	Voltage=0 Current=1
System Configuration	DECS Auxiliary Input Function	2608	Uint32	4	R W	n/a	DECS Input=0 PSS Test Input=1 Grid Code Input=3
System Configuration	DECS Auxiliary Voltage Gain	2610	Float	4	R W	n/a	-99 – 99
System Configuration	DECS Auxiliary Current Gain	2612	Float	4	R W	Percent	-30 – 30
System Configuration	DECS Auxiliary FCR Gain	2614	Float	4	R W	n/a	-99 – 99
System Configuration	DECS Auxiliary var Gain	2616	Float	4	R W	n/a	-99 – 99
System Configuration	DECS Auxiliary PF Gain	2618	Float	4	R W	n/a	-99 – 99
System Configuration	DECS Auto Track Time Delay	2620	Float	4	R W	Second	0–8
System Configuration	DECS Auto Track Traverse Rate	2622	Float	4	R W	Second	1–80
System Configuration	DECS Null Balance Level	2624	Float	4	R W	Percent	0–9999
System Configuration	DECS Auto Trans Time Delay	2626	Float	4	R W	Second	0–8
System Configuration	DECS Auto Trans Traverse Rate	2628	Float	4	R W	Second	1–80
System Configuration	DECS Power Input Base Voltage	2630	Float	4	R W	Volt	1–277
System Configuration	Ambient Temperature	2632	Uint32	4	R W	n/a	Ambient 70°C=0 Ambient 55°C=1
Gen Volt Configuration	Connection	2634	Int32	4	R W	n/a	PT_CA=2 PT_3W_D=7
Gen Volt Configuration	Ratio Primary	2636	Float	4	R W	n/a	1–500000
Gen Volt Configuration	Ratio Secondary	2638	Float	4	R W	n/a	1–600
Gen Volt Configuration	Rated Primary LL	2640	Float	4	R W	Volt	1–90000
Bus Volt Configuration	Connection	2642	Int32	4	R W	n/a	PT_CA=2 PT_3W_D=7
Bus Volt Configuration	Ratio Primary	2644	Float	4	R W	n/a	1–500000
Bus Volt Configuration	Ratio Secondary	2646	Float	4	R W	n/a	1–600
Bus Volt Configuration	Rated Primary LL	2648	Float	4	R W	Volt	1–90000
Gen Current Configuration	Connection	2650	Int32	4	R W	n/a	CT_B=1 CT_ABC=6
Gen Current Configuration	Ratio Primary	2652	Float	4	R W	n/a	1–99999

Group	Name	Register	Type	Bytes	R/W	Unit	Range
Gen Current Configuration	Ratio Secondary	2654	Int32	4	R W	n/a	1=1 5=5
Gen Current Configuration	Rated Primary	2656	Float	4	R	Amp	0–180000
Gen Bus Configuration	Rated kVA	2658	Float	4	R W	KVA	1–1000000
Gen Bus Configuration	Rated PF	2660	Float	4	R W	PF	-2 – 2
Gen Bus Configuration	Rated kW	2662	Float	4	R	kW	-2000000
Gen Bus Configuration	Rated kvar	2664	Float	4	R	Kvar	0–1000000
Gen Bus Configuration	Rotation	2666	Int32	4	R W	n/a	ABC=0 ACB=1
Field Voltage Configuration	Rated Field Voltage Full Load	2668	Float	4	R W	Volt	1–125
Field Voltage Configuration	Rated Field Voltage No Load	2670	Float	4	R W	Volt	1–125
Field Current Configuration	Rated Field Current No Load	2672	Float	4	R W	Amp	0.1–7
Field Current Configuration	Rated Field Current Full Load	2674	Float	4	R W	Amp	0.1–7
Boot Configuration	Pwm Duty	2676	Uint32	4	R W	Percent	0–100
DECS Control	Start Stop Request	2678	Uint32	4	R W	n/a	Stop=0 =1 Start =2
DECS Control	System Option Underfrequency Hz	2680	Float	4	R W	Hertz	10–75
DECS Control	System Input COM Port Manual Enabled	2682	Uint32	4	R W	n/a	Manual=1 Automatic=2
DECS Control	System Input COM Port PF var Enabled	2684	Uint32	4	R W	n/a	Off=0 PF=1 Var=2
DECS Control	System Input COM Port Internal Tracking Enabled	2686	Uint32	4	R W	n/a	Disabled=0 Enabled=1
DECS Control	System Input COM Port External Tracking Enabled	2688	Uint32	4	R W	n/a	Disabled=0 Enabled=1
DECS Control	System Input COM Port Pre-position Enabled	2690	Uint32	4	R W	n/a	NOT SET=0 SET=1
DECS Control	System Input COM Port Pre-position Enabled 2	2692	Uint32	4	R W	n/a	NOT SET=0 SET=1
DECS Control	System Input COM Port Raise Enabled	2694	Uint32	4	R W	n/a	NOT SET=0 Raise=1
DECS Control	System Input COM Port Lower Enabled	2696	Uint32	4	R W	n/a	NOT SET=0 Lower=1
DECS Control	System Option Input Droop Enabled	2698	Uint32	4	R W	n/a	Disabled=0 Enabled=1
DECS Control	System Option Input Line Drop Enabled	2700	Uint32	4	R W	n/a	Disabled=0 Enabled=1
DECS Control	System Option Input Cross Current Enabled	2702	Uint32	4	R W	n/a	Disabled=0 Enabled=1
DECS Control	System Option Input OEL Style Enabled	2704	Uint32	4	R W	n/a	Summing=0 Takeover=1
DECS Control	System Option Input Voltage Match Enabled	2706	Uint32	4	R W	n/a	Disabled=0 Enabled=1
DECS Control	System Option Input OEL Enabled	2708	Uint32	4	R W	n/a	Disabled=0 Enabled=1
DECS Control	System Option Input UEL Enabled	2710	Uint32	4	R W	n/a	Disabled=0 Enabled=1
DECS Control	System Option Input SCL Enabled	2712	Uint32	4	R W	n/a	Disabled=0 Enabled=1
DECS Control	System Option Loss of Sensing Transfer to Manual Mode	2714	Uint32	4	R W	n/a	Status Only=0 Transfer to Manual=1 Shutdown=2
DECS Control	System Option Underfrequency Mode	2716	Uint32	4	R W	n/a	UF Limiter=0 V/Hz Limiter=1
DECS Control	System Option PSS Power Level Enabled	2718	Uint32	4	R W		Disabled=0 Enabled=1
DECS Control	System Option Volts per Hertz Slope High	2720	Float	4	R W	n/a	0–3
DECS Control	System Option Volts per Hertz Slope Low	2722	Float	4	R W	n/a	0–3
DECS Control	System Option Volts per Hertz Slope Time	2724	Float	4	R W	Second	0–10
DECS Control	System Option Voltage Match Band	2726	Float	4	R W	Percent	0–20
DECS Control	System Option Voltage Match Reference	2728	Float	4	R W	Percent	0–700

Group	Name	Register	Type	Bytes	R/W	Unit	Range
DECS Control	System Option Fine Adjust Band	2730	Float	4	R W	Percent	0–30
DECS Control	System Option Underfrequency Slope	2732	Float	4	R W	n/a	0–3
DECS Control	System Option PF to Droop kW Threshold	2734	Float	4	R W	Percent	0–30
DECS Control	Startup Primary Soft-start Bias	2736	Float	4	R W	Percent	0–90
DECS Control	Startup Primary Soft-start Time	2738	Float	4	R W	Second	1–7200
DECS Control	Startup Secondary Soft-start Bias	2740	Float	4	R W	Percent	0–90
DECS Control	Startup Secondary Soft-start Time	2742	Float	4	R W	Second	1–7200
DECS Control	System Input COM Port Preposition 3 Enabled	2744	Uint32	4	R W	n/a	NOT SET=0 SET=1
DECS Control	System Option Underfrequency Hz 2	2746	Float	4	R W	Hertz	1–75
DECS Control	System Option Underfrequency Slope 2	2748	Float	4	R W	n/a	0–3
Auto Save	Enable	2750	Uint32	4	R W	n/a	Disabled=0 Enabled=1
Modbus	Auto Save	2752	Uint16	2	R W	n/a	Off=0 On=1
System Config	Tracking Comms Loss Alarm Enable	2753	Uint32	4	R W	n/a	Disabled=0 Enabled=1
System Config	Tracking Comms Loss Activation Delay	2755	Uint32	4	R W	Second	2–60

Protection Settings

Table 25-12. Protection Settings Group Parameters

Group	Name	Register	Type	Bytes	R/W	Unit	Range
Programmable Alarms	Programmable Alarm 1 Delay	3100	Float	4	R W	Second	0–300
Programmable Alarms	Programmable Alarm 2 Delay	3102	Float	4	R W	Second	0–300
Programmable Alarms	Programmable Alarm 3 Delay	3104	Float	4	R W	Second	0–300
Programmable Alarms	Programmable Alarm 4 Delay	3106	Float	4	R W	Second	0–300
Programmable Alarms	Programmable Alarm 5 Delay	3108	Float	4	R W	Second	0–300
Programmable Alarms	Programmable Alarm 6 Delay	3110	Float	4	R W	Second	0–300
Programmable Alarms	Programmable Alarm 7 Delay	3112	Float	4	R W	Second	0–300
Programmable Alarms	Programmable Alarm 8 Delay	3114	Float	4	R W	Second	0–300
Programmable Alarms	Programmable Alarm 9 Delay	3116	Float	4	R W	Second	0–300
Programmable Alarms	Programmable Alarm 10 Delay	3118	Float	4	R W	Second	0–300
Programmable Alarms	Programmable Alarm 11 Delay	3120	Float	4	R W	Second	0–300
Programmable Alarms	Programmable Alarm 12 Delay	3122	Float	4	R W	Second	0–300
Programmable Alarms	Programmable Alarm 13 Delay	3124	Float	4	R W	Second	0–300
Programmable Alarms	Programmable Alarm 14 Delay	3126	Float	4	R W	Second	0–300
Programmable Alarms	Programmable Alarm 15 Delay	3128	Float	4	R W	Second	0–300
Programmable Alarms	Programmable Alarm 16 Delay	3130	Float	4	R W	Second	0–300
Field Overvoltage	Primary Mode	3132	Uint32	4	R W	n/a	Disabled=0 Enabled=1
Field Overvoltage	Primary Pickup	3134	Float	4	R W	V	Disabled=0, 1–300
Field Overvoltage	Primary Time Delay	3136	Float	4	R W	Millisecond	Instantaneous=0, 0–30000
Field Overvoltage	Secondary Mode	3138	Uint32	4	R W	n/a	Disabled=0 Enabled=1
Field Overvoltage	Secondary Pickup	3140	Float	4	R W	V	Disabled=0, 1 - 300

Group	Name	Register	Type	Bytes	R/W	Unit	Range
Field Overvoltage	Secondary Time Delay	3142	Float	4	R W	Millisecond	Instantaneous=0, 0–30000
Loss Of Sensing	Mode	3144	Uint32	4	R W	n/a	Disabled=0 Enabled=1
Loss Of Sensing	Time Delay	3146	Float	4	R W	Second	0–30
Loss Of Sensing	Voltage Balanced Level	3148	Float	4	R W	Percent	0–100
Loss Of Sensing	Voltage Unbalanced Level	3150	Float	4	R W	Percent	0–100
EDM	Mode	3152	Uint32	4	R W	n/a	Disabled=0 Enabled=1
EDM	Pickup	3154	Float	4	R W	Amp	0; 1–10
EDM	Time Delay	3156	Float	4	R W	Millisecond	0; 200–30000
25	Mode	3158	Uint32	4	R W	n/a	Disabled=0 Enabled=1
25	Slip Angle	3160	Float	4	R W	Degree	1–99
25	Slip Frequency	3162	Float	4	R W	Hertz	0.01–0.5
25	Voltage Difference	3164	Float	4	R W	Percent	0.1–50
25	Generator Frequency Greater Than Bus Frequency	3166	Uint32	4	R W	n/a	Disabled=0 Enabled=1
25	Angle Compensation	3168	Float	4	R W	Degree	0–359.9
27P	Primary Mode	3170	Uint32	4	R W	n/a	Disabled=0 Enabled=1
27P	Primary Pickup	3172	Float	4	R W	Volt	Disabled=0, 0–99999
27P	Primary Time Delay	3174	Float	4	R W	Millisecond	100–60000
27P	Secondary Mode	3176	Uint32	4	R W	n/a	Disabled=0 Enabled=1
27P	Secondary Pickup	3178	Float	4	R W	Volt	Disabled=0, 0–999999
27P	Secondary Time Delay	3180	Float	4	R W	Millisecond	100–60000
59P	Primary Mode	3182	Uint32	4	R W	n/a	Disabled=0 Enabled=1
59P	Primary Pickup	3184	Float	4	R W	Volt	Disabled=0, 0–99999
59P	Primary Time Delay	3186	Float	4	R W	Millisecond	100–60000
59P	Secondary Mode	3188	Uint32	4	R W	n/a	Disabled=0 Enabled=1
59P	Secondary Pickup	3190	Float	4	R W	Volt	Disabled=0, 0–99999
59P	Secondary Time Delay	3192	Float	4	R W	Millisecond	100–60000
81O	Primary Mode	3194	Uint32	4	R W	n/a	Disabled=0 Over=1
81O	Primary Pickup	3196	Float	4	R W	Hertz	Disabled=0, 30 - 70
81O	Primary Time Delay	3198	Float	4	R W	Millisecond	100 - 300000
81O	Primary Voltage Inhibit	3200	Float	4	R W	Percent	0; 5 - 100
81O	Secondary Mode	3202	Uint32	4	R W	n/a	Disabled=0 Over=1
81O	Secondary Pickup	3204	Float	4	R W	Hertz	Disabled=0, 30–70
81O	Secondary Time Delay	3206	Float	4	R W	Millisecond	100–300000
81O	Secondary Voltage Inhibit	3208	Float	4	R W	Percent	0; 5–100
81U	Primary Mode	3210	Uint32	4	R W	n/a	Disabled=0 Under=2
81U	Primary Pickup	3212	Float	4	R W	Hertz	Disabled=0, 30–70
81U	Primary Time Delay	3214	Float	4	R W	Millisecond	100–300000
81U	Primary Voltage Inhibit	3216	Float	4	R W	Percent	Disabled=0, 5–100
81U	Secondary Mode	3218	Uint32	4	R W	n/a	Disabled=0 Under=2
81U	Secondary Pickup	3220	Float	4	R W	Hertz	Disabled=0, 30–70
81U	Secondary Time Delay	3222	Float	4	R W	Millisecond	100–300000
81U	Secondary Voltage Inhibit	3224	Float	4	R W	Percent	Disabled=0, 5–100

Group	Name	Register	Type	Bytes	R/W	Unit	Range
Configurable Protection 1	Parameter Selection	3226	Int32	4	R W	n/a	Gen VAB=0 Gen VBC=1 Gen VCA=2 Gen V Average=3 Bus Freq=4 Bus VAB=5 Bus VBC=6 Bus VCA=7 Gen Freq=8 Gen PF=9 KWH=10 KVARH=11 Gen IA=12 Gen IB=13 Gen IC=14 Gen I Average=15 KW Total=16 KVA Total=17 KVAR Total=18 EDM Ripple=19 Vfd=20 Ifd=21 Auxiliary Input Voltage=22 Auxiliary Input Current (mA)=23 Setpoint Position=24 Tracking_Error=25 Neg_Seq_V=26 Neg_Seq_I=27 Pos_Seq_V=28 Pos_Seq_I=29 PSS_Output=30 Power Input=49 KW A=50 KW B=51 KW C=52 KVAR A=53 KVAR B=54 KVAR C=55 KVA A=56 KVA B=57 KVA C=58 Gen VAN=59 Gen VBN=60 Gen VCN=61 Cross Current=62 GenScaledPF=63 Network Load Share Error Percent=65 No Param Selected=64 LVRT Output=66 APC Output=67
Configurable Protection 1	Hysteresis	3228	Float	4	R W	Percent	0-100
Configurable Protection 1	Arming Delay	3230	Float	4	R W	Second	0-300
Configurable Protection 1	Stop Mode Inhibit	3232	Int32	4	R W	n/a	No=0 Yes=1
Configurable Protection 1	Threshold 1 Type	3234	Int32	4	R W	n/a	Disabled=0 Over=1 Under=2
Configurable Protection 1	Threshold 1 Pickup	3236	Float	4	R W	n/a	-999999 – 999999
Configurable Protection 1	Threshold 1 Activation Delay	3238	Float	4	R W	Second	0-300
Configurable Protection 1	Threshold 2 Type	3240	Int32	4	R W	n/a	Disabled=0 Over=1 Under=2
Configurable Protection 1	Threshold 2 Pickup	3242	Float	4	R W	n/a	-999999 – 999999
Configurable Protection 1	Threshold 2 Activation Delay	3244	Float	4	R W	Second	0-300
Configurable Protection 1	Threshold 3 Type	3246	Int32	4	R W	n/a	Disabled=0 Over=1 Under=2
Configurable Protection 1	Threshold 3 Pickup	3248	Float	4	R W	n/a	-999999 – 999999
Configurable Protection 1	Threshold 3 Activation Delay	3250	Float	4	R W	Second	0-300
Configurable Protection 1	Threshold 4 Type	3252	Int32	4	R W	n/a	Disabled=0 Over=1 Under=2
Configurable Protection 1	Threshold 4 Pickup	3254	Float	4	R W	n/a	-999999 – 999999
Configurable Protection 1	Threshold 4 Activation Delay	3256	Float	4	R W	Second	0-300
Configurable Protection 1	Label	3258	String	16	R W	n/a	0-16
Configurable Protection 2	Parameter Selection	3266	Int32	4	R W	n/a	Gen VAB=0 Gen VBC=1 Gen VCA=2 Gen V Average=3 Bus Freq=4 Bus VAB=5 Bus VBC=6 Bus VCA=7 Gen Freq=8 Gen PF=9 KWH=10 KVARH=11 Gen IA=12 Gen IB=13 Gen IC=14 Gen I Average=15 KW Total=16 KVA Total=17 KVAR Total=18 EDM Ripple=19 Vfd=20 Ifd=21 Auxiliary Input Voltage=22 Auxiliary Input Current (mA)=23 Setpoint Position=24 Tracking_Error=25 Neg_Seq_V=26 Neg_Seq_I=27 Pos_Seq_V=28 Pos_Seq_I=29 PSS_Output=30 Power Input=49 KW A=50 KW B=51 KW C=52 KVAR A=53 KVAR B=54 KVAR C=55 KVA A=56 KVA B=57 KVA C=58 Gen VAN=59 Gen VBN=60 Gen VCN=61 Cross Current=62 GenScaledPF=63 Network Load Share Error Percent=65 No Param Selected=64 LVRT Output=66 APC Output=67
Configurable Protection 2	Hysteresis	3268	Float	4	R W	Percent	0-100
Configurable Protection 2	Arming Delay	3270	Float	4	R W	Second	0-300

Group	Name	Register	Type	Bytes	R/W	Unit	Range
Configurable Protection 2	Stop Mode Inhibit	3272	Int32	4	R W	n/a	No=0 Yes=1
Configurable Protection 2	Threshold 1 Type	3274	Int32	4	R W	n/a	Disabled=0 Over=1 Under=2
Configurable Protection 2	Threshold 1 Pickup	3276	Float	4	R W	n/a	-999999 – 999999
Configurable Protection 2	Threshold 1 Activation Delay	3278	Float	4	R W	Second	0–300
Configurable Protection 2	Threshold 2 Type	3280	Int32	4	R W	n/a	Disabled=0 Over=1 Under=2
Configurable Protection 2	Threshold 2 Pickup	3282	Float	4	R W	n/a	-999999 – 999999
Configurable Protection 2	Threshold 2 Activation Delay	3284	Float	4	R W	Second	0–300
Configurable Protection 2	Threshold 3 Type	3286	Int32	4	R W	n/a	Disabled=0 Over=1 Under=2
Configurable Protection 2	Threshold 3 Pickup	3288	Float	4	R W	n/a	-999999 – 999999
Configurable Protection 2	Threshold 3 Activation Delay	3290	Float	4	R W	Second	0–300
Configurable Protection 2	Threshold 4 Type	3292	Int32	4	R W	n/a	Disabled=0 Over=1 Under=2
Configurable Protection 2	Threshold 4 Pickup	3294	Float	4	R W	n/a	-999999 – 999999
Configurable Protection 2	Threshold 4 Activation Delay	3296	Float	4	R W	Second	0–300
Configurable Protection 2	Label	3298	String	16	R W	n/a	0–16
Configurable Protection 3	Parameter Selection	3306	Int32	4	R W	n/a	Gen VAB=0 Gen VBC=1 Gen VCA=2 Gen V Average=3 Bus Freq=4 Bus VAB=5 Bus VBC=6 Bus VCA=7 Gen Freq=8 Gen PF=9 KWH=10 KVARH=11 Gen IA=12 Gen IB=13 Gen IC=14 Gen I Average=15 KW Total=16 KVA Total=17 KVAR Total=18 EDM Ripple=19 Vfd=20 lfd=21 Auxiliary Input Voltage=22 Auxiliary Input Current (mA)=23 Setpoint Position=24 Tracking_Error=25 Neg_Seq_V=26 Neg_Seq_I=27 Pos_Seq_V=28 Pos_Seq_I=29 PSS_Output=30 Power Input=49 KW A=50 KW B=51 KW C=52 KVAR A=53 KVAR B=54 KVAR C=55 KVA A=56 KVA B=57 KVA C=58 Gen VAN=59 Gen VBN=60 Gen VCN=61 Cross Current=62 GenScaledPF=63 Network Load Share Error Percent=65 No Param Selected=64 LVRT Output=66 APC Output=67
Configurable Protection 3	Hysteresis	3308	Float	4	R W	Percent	0–100
Configurable Protection 3	Arming Delay	3310	Float	4	R W	Second	0–300
Configurable Protection 3	Stop Mode Inhibit	3312	Int32	4	R W	n/a	No=0 Yes=1
Configurable Protection 3	Threshold 1 Type	3314	Int32	4	R W	n/a	Disabled=0 Over=1 Under=2
Configurable Protection 3	Threshold 1 Pickup	3316	Float	4	R W	n/a	-999999 – 999999
Configurable Protection 3	Threshold 1 Activation Delay	3318	Float	4	R W	Second	0–300
Configurable Protection 3	Threshold 2 Type	3320	Int32	4	R W	n/a	Disabled=0 Over=1 Under=2
Configurable Protection 3	Threshold 2 Pickup	3322	Float	4	R W	n/a	-999999 – 999999
Configurable Protection 3	Threshold 2 Activation Delay	3324	Float	4	R W	Second	0–300
Configurable Protection 3	Threshold 3 Type	3326	Int32	4	R W	n/a	Disabled=0 Over=1 Under=2
Configurable Protection 3	Threshold 3 Pickup	3328	Float	4	R W	n/a	-999999 – 999999
Configurable Protection 3	Threshold 3 Activation Delay	3330	Float	4	R W	Second	0–300
Configurable Protection 3	Threshold 4 Type	3332	Int32	4	R W	n/a	Disabled=0 Over=1 Under=2
Configurable Protection 3	Threshold 4 Pickup	3334	Float	4	R W	n/a	-999999 – 999999
Configurable Protection 3	Threshold 4 Activation Delay	3336	Float	4	R W	Second	0–300
Configurable Protection 3	Label	3338	String	16	R W	n/a	0–16

Group	Name	Register	Type	Bytes	R/W	Unit	Range
Configurable Protection 4	Parameter Selection	3346	Int32	4	R W	n/a	Gen VAB=0 Gen VBC=1 Gen VCA=2 Gen V Average=3 Bus Freq=4 Bus VAB=5 Bus VBC=6 Bus VCA=7 Gen Freq=8 Gen PF=9 KWH=10 KVARH=11 Gen IA=12 Gen IB=13 Gen IC=14 Gen I Average=15 KW Total=16 KVA Total=17 KVAR Total=18 EDM Ripple=19 Vfd=20 Ifd=21 Auxiliary Input Voltage=22 Auxiliary Input Current (mA)=23 Setpoint Position=24 Tracking_Error=25 Neg_Seq_V=26 Neg_Seq_I=27 Pos_Seq_V=28 Pos_Seq_I=29 PSS_Output=30 Power Input=49 KW A=50 KW B=51 KW C=52 KVAR A=53 KVAR B=54 KVAR C=55 KVA A=56 KVA B=57 KVA C=58 Gen VAN=59 Gen VBN=60 Gen VCN=61 Cross Current=62 GenScaledPF=63 Network Load Share Error Percent=65 No Param Selected=64 LVRT Output=66 APC Output=67
Configurable Protection 4	Hysteresis	3348	Float	4	R W	Percent	0-100
Configurable Protection 4	Arming Delay	3350	Float	4	R W	Second	0-300
Configurable Protection 4	Stop Mode Inhibit	3352	Int32	4	R W	n/a	No=0 Yes=1
Configurable Protection 4	Threshold 1 Type	3354	Int32	4	R W	n/a	Disabled=0 Over=1 Under=2
Configurable Protection 4	Threshold 1 Pickup	3356	Float	4	R W	n/a	-999999 – 999999
Configurable Protection 4	Threshold 1 Activation Delay	3358	Float	4	R W	Second	0-300
Configurable Protection 4	Threshold 2 Type	3360	Int32	4	R W	n/a	Disabled=0 Over=1 Under=2
Configurable Protection 4	Threshold 2 Pickup	3362	Float	4	R W	n/a	-999999 – 999999
Configurable Protection 4	Threshold 2 Activation Delay	3364	Float	4	R W	Second	0-300
Configurable Protection 4	Threshold 3 Type	3366	Int32	4	R W	n/a	Disabled=0 Over=1 Under=2
Configurable Protection 4	Threshold 3 Pickup	3368	Float	4	R W	n/a	-999999 – 999999
Configurable Protection 4	Threshold 3 Activation Delay	3370	Float	4	R W	Second	0-300
Configurable Protection 4	Threshold 4 Type	3372	Int32	4	R W	n/a	Disabled=0 Over=1 Under=2
Configurable Protection 4	Threshold 4 Pickup	3374	Float	4	R W	n/a	-999999 – 999999
Configurable Protection 4	Threshold 4 Activation Delay	3376	Float	4	R W	Second	0-300
Configurable Protection 4	Label	3378	String	16	R W	n/a	0-16
Configurable Protection 5	Parameter Selection	3386	Int32	4	R W	n/a	Gen VAB=0 Gen VBC=1 Gen VCA=2 Gen V Average=3 Bus Freq=4 Bus VAB=5 Bus VBC=6 Bus VCA=7 Gen Freq=8 Gen PF=9 KWH=10 KVARH=11 Gen IA=12 Gen IB=13 Gen IC=14 Gen I Average=15 KW Total=16 KVA Total=17 KVAR Total=18 EDM Ripple=19 Vfd=20 Ifd=21 Auxiliary Input Voltage=22 Auxiliary Input Current (mA)=23 Setpoint Position=24 Tracking_Error=25 Neg_Seq_V=26 Neg_Seq_I=27 Pos_Seq_V=28 Pos_Seq_I=29 PSS_Output=30 Power Input=49 KW A=50 KW B=51 KW C=52 KVAR A=53 KVAR B=54 KVAR C=55 KVA A=56 KVA B=57 KVA C=58 Gen VAN=59 Gen VBN=60 Gen VCN=61 Cross Current=62 GenScaledPF=63 Network Load Share Error Percent=65 No Param Selected=64 LVRT Output=66 APC Output=67
Configurable Protection 5	Hysteresis	3388	Float	4	R W	Percent	0-100
Configurable Protection 5	Arming Delay	3390	Float	4	R W	Second	0-300

Group	Name	Register	Type	Bytes	R/W	Unit	Range
Configurable Protection 5	Stop Mode Inhibit	3392	Int32	4	R W	n/a	No=0 Yes=1
Configurable Protection 5	Threshold 1 Type	3394	Int32	4	R W	n/a	Disabled=0 Over=1 Under=2
Configurable Protection 5	Threshold 1 Pickup	3396	Float	4	R W	n/a	-999999 – 999999
Configurable Protection 5	Threshold 1 Activation Delay	3398	Float	4	R W	Second	0–300
Configurable Protection 5	Threshold 2 Type	3400	Int32	4	R W	n/a	Disabled=0 Over=1 Under=2
Configurable Protection 5	Threshold 2 Pickup	3402	Float	4	R W	n/a	-999999 – 999999
Configurable Protection 5	Threshold 2 Activation Delay	3404	Float	4	R W	Second	0–300
Configurable Protection 5	Threshold 3 Type	3406	Int32	4	R W	n/a	Disabled=0 Over=1 Under=2
Configurable Protection 5	Threshold 3 Pickup	3408	Float	4	R W	n/a	-999999 – 999999
Configurable Protection 5	Threshold 3 Activation Delay	3410	Float	4	R W	Second	0–300
Configurable Protection 5	Threshold 4 Type	3412	Int32	4	R W	n/a	Disabled=0 Over=1 Under=2
Configurable Protection 5	Threshold 4 Pickup	3414	Float	4	R W	n/a	-999999 – 999999
Configurable Protection 5	Threshold 4 Activation Delay	3416	Float	4	R W	Second	0–300
Configurable Protection 5	Label	3418	String	16	R W	n/a	0–16
Configurable Protection 6	Parameter Selection	3426	Int32	4	R W	n/a	Gen VAB=0 Gen VBC=1 Gen VCA=2 Gen V Average=3 Bus Freq=4 Bus VAB=5 Bus VBC=6 Bus VCA=7 Gen Freq=8 Gen PF=9 KWH=10 KVARH=11 Gen IA=12 Gen IB=13 Gen IC=14 Gen I Average=15 KW Total=16 KVA Total=17 KVAR Total=18 EDM Ripple=19 Vfd=20 Ifd=21 Auxiliary Input Voltage=22 Auxiliary Input Current (mA)=23 Setpoint Position=24 Tracking_Error=25 Neg_Seq_V=26 Neg_Seq_I=27 Pos_Seq_V=28 Pos_Seq_I=29 PSS_Output=30 Power Input=49 KW A=50 KW B=51 KW C=52 KVAR A=53 KVAR B=54 KVAR C=55 KVA A=56 KVA B=57 KVA C=58 Gen VAN=59 Gen VBN=60 Gen VCN=61 Cross Current=62 GenScaledPF=63 Network Load Share Error Percent=65 No Param Selected=64 LVRT Output=66 APC Output=67
Configurable Protection 6	Hysteresis	3428	Float	4	R W	Percent	0–100
Configurable Protection 6	Arming Delay	3430	Float	4	R W	Second	0–300
Configurable Protection 6	Stop Mode Inhibit	3432	Int32	4	R W	n/a	No=0 Yes=1
Configurable Protection 6	Threshold 1 Type	3434	Int32	4	R W	n/a	Disabled=0 Over=1 Under=2
Configurable Protection 6	Threshold 1 Pickup	3436	Float	4	R W	n/a	-999999 – 999999
Configurable Protection 6	Threshold 1 Activation Delay	3438	Float	4	R W	Second	0–300
Configurable Protection 6	Threshold 2 Type	3440	Int32	4	R W	n/a	Disabled=0 Over=1 Under=2
Configurable Protection 6	Threshold 2 Pickup	3442	Float	4	R W	n/a	-999999 – 999999
Configurable Protection 6	Threshold 2 Activation Delay	3444	Float	4	R W	Second	0–300
Configurable Protection 6	Threshold 3 Type	3446	Int32	4	R W	n/a	Disabled=0 Over=1 Under=2
Configurable Protection 6	Threshold 3 Pickup	3448	Float	4	R W	n/a	-999999 – 999999
Configurable Protection 6	Threshold 3 Activation Delay	3450	Float	4	R W	Second	0–300
Configurable Protection 6	Threshold 4 Type	3452	Int32	4	R W	n/a	Disabled=0 Over=1 Under=2
Configurable Protection 6	Threshold 4 Pickup	3454	Float	4	R W	n/a	-999999 – 999999
Configurable Protection 6	Threshold 4 Activation Delay	3456	Float	4	R W	Second	0–300
Configurable Protection 6	Label	3458	String	16	R W	n/a	0–16

Group	Name	Register	Type	Bytes	R/W	Unit	Range
Configurable Protection 7	Parameter Selection	3466	Int32	4	R W	n/a	Gen VAB=0 Gen VBC=1 Gen VCA=2 Gen V Average=3 Bus Freq=4 Bus VAB=5 Bus VBC=6 Bus VCA=7 Gen Freq=8 Gen PF=9 KWH=10 KVARH=11 Gen IA=12 Gen IB=13 Gen IC=14 Gen I Average=15 KW Total=16 KVA Total=17 KVAR Total=18 EDM Ripple=19 Vfd=20 Ifd=21 Auxiliary Input Voltage=22 Auxiliary Input Current (mA)=23 Setpoint Position=24 Tracking_Error=25 Neg_Seq_V=26 Neg_Seq_I=27 Pos_Seq_V=28 Pos_Seq_I=29 PSS_Output=30 Power Input=49 KW A=50 KW B=51 KW C=52 KVAR A=53 KVAR B=54 KVAR C=55 KVA A=56 KVA B=57 KVA C=58 Gen VAN=59 Gen VBN=60 Gen VCN=61 Cross Current=62 GenScaledPF=63 Network Load Share Error Percent=65 No Param Selected=64 LVRT Output=66 APC Output=67
Configurable Protection 7	Hysteresis	3468	Float	4	R W	Percent	0-100
Configurable Protection 7	Arming Delay	3470	Float	4	R W	Second	0-300
Configurable Protection 7	Stop Mode Inhibit	3472	Int32	4	R W	n/a	No=0 Yes=1
Configurable Protection 7	Threshold 1 Type	3474	Int32	4	R W	n/a	Disabled=0 Over=1 Under=2
Configurable Protection 7	Threshold 1 Pickup	3476	Float	4	R W	n/a	-999999 – 999999
Configurable Protection 7	Threshold 1 Activation Delay	3478	Float	4	R W	Second	0-300
Configurable Protection 7	Threshold 2 Type	3480	Int32	4	R W	n/a	Disabled=0 Over=1 Under=2
Configurable Protection 7	Threshold 2 Pickup	3482	Float	4	R W	n/a	-999999 – 999999
Configurable Protection 7	Threshold 2 Activation Delay	3484	Float	4	R W	Second	0-300
Configurable Protection 7	Threshold 3 Type	3486	Int32	4	R W	n/a	Disabled=0 Over=1 Under=2
Configurable Protection 7	Threshold 3 Pickup	3488	Float	4	R W	n/a	-999999 – 999999
Configurable Protection 7	Threshold 3 Activation Delay	3490	Float	4	R W	Second	0-300
Configurable Protection 7	Threshold 4 Type	3492	Int32	4	R W	n/a	Disabled=0 Over=1 Under=2
Configurable Protection 7	Threshold 4 Pickup	3494	Float	4	R W	n/a	-999999 – 999999
Configurable Protection 7	Threshold 4 Activation Delay	3496	Float	4	R W	Second	0-300
Configurable Protection 7	Label	3498	String	16	R W	n/a	0-16
Configurable Protection 8	Parameter Selection	3506	Int32	4	R W	n/a	Gen VAB=0 Gen VBC=1 Gen VCA=2 Gen V Average=3 Bus Freq=4 Bus VAB=5 Bus VBC=6 Bus VCA=7 Gen Freq=8 Gen PF=9 KWH=10 KVARH=11 Gen IA=12 Gen IB=13 Gen IC=14 Gen I Average=15 KW Total=16 KVA Total=17 KVAR Total=18 EDM Ripple=19 Vfd=20 Ifd=21 Auxiliary Input Voltage=22 Auxiliary Input Current (mA)=23 Setpoint Position=24 Tracking_Error=25 Neg_Seq_V=26 Neg_Seq_I=27 Pos_Seq_V=28 Pos_Seq_I=29 PSS_Output=30 Power Input=49 KW A=50 KW B=51 KW C=52 KVAR A=53 KVAR B=54 KVAR C=55 KVA A=56 KVA B=57 KVA C=58 Gen VAN=59 Gen VBN=60 Gen VCN=61 Cross Current=62 GenScaledPF=63 Network Load Share Error Percent=65 No Param Selected=64 LVRT Output=66 APC Output=67
Configurable Protection 8	Hysteresis	3508	Float	4	R W	Percent	0-100
Configurable Protection 8	Arming Delay	3510	Float	4	R W	Second	0-300

Group	Name	Register	Type	Bytes	R/W	Unit	Range
Configurable Protection 8	Stop Mode Inhibit	3512	Int32	4	R W	n/a	No=0 Yes=1
Configurable Protection 8	Threshold 1 Type	3514	Int32	4	R W	n/a	Disabled=0 Over=1 Under=2
Configurable Protection 8	Threshold 1 Pickup	3516	Float	4	R W	n/a	-999999 – 999999
Configurable Protection 8	Threshold 1 Activation Delay	3518	Float	4	R W	Second	0–300
Configurable Protection 8	Threshold 2 Type	3520	Int32	4	R W	n/a	Disabled=0 Over=1 Under=2
Configurable Protection 8	Threshold 2 Pickup	3522	Float	4	R W	n/a	-999999 – 999999
Configurable Protection 8	Threshold 2 Activation Delay	3524	Float	4	R W	Second	0–300
Configurable Protection 8	Threshold 3 Type	3526	Int32	4	R W	n/a	Disabled=0 Over=1 Under=2
Configurable Protection 8	Threshold 3 Pickup	3528	Float	4	R W	n/a	-999999 – 999999
Configurable Protection 8	Threshold 3 Activation Delay	3530	Float	4	R W	Second	0–300
Configurable Protection 8	Threshold 4 Type	3532	Int32	4	R W	n/a	Disabled=0 Over=1 Under=2
Configurable Protection 8	Threshold 4 Pickup	3534	Float	4	R W	n/a	-999999 – 999999
Configurable Protection 8	Threshold 4 Activation Delay	3536	Float	4	R W	Second	0–300
Configurable Protection 8	Label	3538	String	16	R W	n/a	0–16
Hardware Shutdown	OEL Shutdown Enable	3546	UInt32	4	R W	n/a	Disabled=0 Enabled=1
Hardware Shutdown	OEL Shutdown Delay	3548	Float	4	R W	Second	0–30
Hardware Shutdown	UEL Shutdown Enable	3550	UInt32	4	R W	n/a	Disabled=0 Enabled=1
Hardware Shutdown	UEL Shutdown Delay	3552	Float	4	R W	Second	0–30
Hardware Shutdown	SCL Shutdown Enable	3554	UInt32	4	R W	n/a	Disabled=0 Enabled=1
Hardware Shutdown	SCL Shutdown Delay	3556	Float	4	R W	Second	0–30
Hardware Shutdown	27 Shutdown Enable	3558	UInt32	4	R W	n/a	Disabled=0 Enabled=1
Hardware Shutdown	59 Shutdown Enable	3560	UInt32	4	R W	n/a	Disabled=0 Enabled=1
Hardware Shutdown	81O Shutdown Enable	3562	UInt32	4	R W	n/a	Disabled=0 Enabled=1
Hardware Shutdown	81U Shutdown Enable	3564	UInt32	4	R W	n/a	Disabled=0 Enabled=1
Hardware Shutdown	EDM Shutdown Enable	3566	Unit32	4	R W	n/a	Disabled=0 Enabled=1
Hardware Shutdown	Field Overvoltage Shutdown Enable	3568	UInt32	4	R W	n/a	Disabled=0 Enabled=1
Hardware Shutdown	Field Short Circuit Shutdown Enable	3570	UInt32	4	R W	n/a	Disabled=0 Enabled=1

Gains Settings

Table 25-13. Gains Settings Group Parameters

Name	Register	Type	Bytes	R/W	Unit	Range
Primary Gain Option	3800	UInt32	4	R W	n/a	T'do=1.0 Te=0.17=1 T'do=1.5 Te=0.25=2 T'do=2.0 Te=0.33=3 T'do=2.5 Te=0.42=4 T'do=3.0 Te=0.50=5 T'do=3.5 Te=0.58=6 T'do=4.0 Te=0.67=7 T'do=4.5 Te=0.75=8 T'do=5.0 Te=0.83=9 T'do=5.5 Te=0.92=10 T'do=6.0 Te=1.00=11 T'do=6.5 Te=1.08=12 T'do=7.0 Te=1.17=13 T'do=7.5 Te=1.25=14 T'do=8.0 Te=1.33=15 T'do=8.5 Te=1.42=16 T'do=9.0 Te=1.50=17 T'do=9.5 Te=1.58=18

Name	Register	Type	Bytes	R/W	Unit	Range
Secondary Gain Option	3802	Uint32	4	R W	n/a	T'do=1.0 Te=0.17=1 T'do=1.5 Te=0.25=2 T'do=2.0 Te=0.33=3 T'do=2.5 Te=0.42=4 T'do=3.0 Te=0.50=5 T'do=3.5 Te=0.58=6 T'do=4.0 Te=0.67=7 T'do=4.5 Te=0.75=8 T'do=5.0 Te=0.83=9 T'do=5.5 Te=0.92=10 T'do=6.0 Te=1.00=11 T'do=6.5 Te=1.08=12 T'do=7.0 Te=1.17=13 T'do=7.5 Te=1.25=14 T'do=8.0 Te=1.33=15 T'do=8.5 Te=1.42=16 T'do=9.0 Te=1.50=17 T'do=9.5 Te=1.58=18
AVR Kp Primary	3804	Float	4	R W	n/a	0–1000
AVR Ki Primary	3806	Float	4	R W	n/a	0–1000
AVR Kd Primary	3808	Float	4	R W	n/a	0–1000
AVR Td Primary	3810	Float	4	R W	n/a	0–1
FCR Kp	3812	Float	4	R W	n/a	0–1000
FCR Ki	3814	Float	4	R W	n/a	0–1000
FCR Kd	3816	Float	4	R W	n/a	0–1000
FCR Td	3818	Float	4	R W	n/a	0–1
PF Ki	3820	Float	4	R W	n/a	0–1000
PF Kg	3822	Float	4	R W	n/a	0–1000
Var Ki	3824	Float	4	R W	n/a	0–1000
Var Kg	3826	Float	4	R W	n/a	0–1000
OEL Ki	3828	Float	4	R W	n/a	0–1000
OEL Kg	3830	Float	4	R W	n/a	0–1000
UEL Ki	3832	Float	4	R W	n/a	0–1000
UEL Kg	3834	Float	4	R W	n/a	0–1000
SCL Ki	3836	Float	4	R W	n/a	0–1000
SCL Kg	3846	Float	4	R W	n/a	0–1000
Vm Kg	3840	Float	4	R W	n/a	0–1000
AVR Kp Secondary	3842	Float	4	R W	n/a	0–1000
AVR Ki Secondary	3844	Float	4	R W	n/a	0–1000
AVR Kd Secondary	3846	Float	4	R W	n/a	0–1000
AVR Td Secondary	3848	Float	4	R W	n/a	0–1
AVR Ka Primary	3850	Float	4	R W	n/a	0–1
AVR Ka Secondary	3852	Float	4	R W	n/a	0–1
FCR Ka	3854	Float	4	R W	n/a	0–1

PSS Settings

Table 25-14. PSS Settings Group Parameters

Name	Register	Type	Bytes	R/W	Unit	Range
PSS Enable	4300	Uint32	4	R W	n/a	Disabled=0 Enabled=1
PSS Primary M	4302	Uint32	4	R W	n/a	1–5
PSS Primary N	4304	Uint32	4	R W	n/a	0–1
PSS SSW 4 – Torsional Filter 1	4306	Uint32	4	R W	n/a	Disabled=0 Enabled=1
PSS SSW 5 – Torsional Filter 2	4308	Uint32	4	R W	n/a	Disabled=0 Enabled=1
PSS SSW 2 – PSS Signal	4310	Uint32	4	R W	n/a	Frequency=0 Der. Speed=1
PSS SSW 3 – PSS Signal	4312	Uint32	4	R W	n/a	Power=0 Der. Freq/Speed=1
PSS SSW 6 – 3rd Lead/Lag Stage	4314	Uint32	4	R W	n/a	Exclude=0 Include=1
PSS SSW 8 – Term. Voltage Limiter	4316	Uint32	4	R W	n/a	Disabled=0 Enabled=1
PSS SSW 10 – PSS Output	4318	Uint32	4	R W	n/a	Off=0 On=1
PSS SSW 9 – Logic Limiter	4320	Uint32	4	R W	n/a	Disabled=0 Enabled=1

Name	Register	Type	Bytes	R/W	Unit	Range
PSS SSW 7 – 4th Lead/Lag Stage	4322	Uint32	4	R W	n/a	Exclude=0 Include=1
PSS SSW 0 – Speed Low Pass Filter	4324	Uint32	4	R W	n/a	Disabled=0 Enabled=1
PSS SSW 1 – Power Washout Filter #2	4326	Uint32	4	R W	n/a	Disabled=0 Enabled=1
PSS Primary Tw1	4328	Float	4	R W	Second	1–20
PSS Primary Tw2	4330	Float	4	R W	Second	1–20
PSS Primary H	4332	Float	4	R W	n/a	0.01–25
PSS Primary T11	4334	Float	4	R W	Second	0–20
PSS Primary T1	4336	Float	4	R W	Second	0.001–6
PSS Primary T2	4338	Float	4	R W	Second	0.001–6
PSS Primary T3	4340	Float	4	R W	Second	0.001–6
PSS Primary T4	4342	Float	4	R W	Second	0.001–6
PSS Primary T5	4344	Float	4	R W	Second	0.001– 6
PSS Primary T6	4346	Float	4	R W	Second	0.001–6
PSS Primary T7	4348	Float	4	R W	Second	0.001–6
PSS Primary T8	4350	Float	4	R W	Second	0.001–6
PSS Primary Terminal Voltage Limiter Time Constant	4352	Float	4	R W	Second	0.02–5
PSS Primary Terminal Voltage Limiter Setpoint	4354	Float	4	R W	n/a	0–10
PSS Primary Zeta Num 1	4356	Float	4	R W	n/a	0–1
PSS Primary Zeta Den 1	4358	Float	4	R W	n/a	0–1
PSS Primary Wn 1	4360	Float	4	R W	n/a	10–150
PSS Primary Zeta Num 2	4362	Float	4	R W	n/a	0–1
PSS Primary Zeta Den 2	4364	Float	4	R W	n/a	0–1
PSS Primary Wn 2	4366	Float	4	R W	n/a	10–150
PSS Primary Logic Output Limiter Upper Limit	4368	Float	4	R W	n/a	0.01–0.04
PSS Primary Logic Output Limiter Lower Limit	4370	Float	4	R W	n/a	-0.040 – -0.010
PSS Primary Logic Output Limiter Time Delay	4372	Float	4	R W	n/a	0–2
PSS Primary Logic Limiter Washout Filter Normal Time	4374	Float	4	R W	n/a	5–30
PSS Primary Logic Limiter Washout Filter Limit Time	4376	Float	4	R W	n/a	0–1
PSS Primary Stabilizer Gain Ks	4378	Float	4	R W	n/a	-100 – 100
PSS Primary Output Limiting Upper Limit	4380	Float	4	R W	n/a	0–0.5
PSS Primary Output Limiting Lower Limit	4382	Float	4	R W	n/a	-0.5 – 0
PSS Primary Xq	4384	Float	4	R W	n/a	0–5
PSS Primary Power Level Threshold	4386	Float	4	R W	n/a	0–1
PSS Primary Power Level Hysteresis	4388	Float	4	R W	n/a	0–1
PSS Primary Tw3	4390	Float	4	R W	Second	1–20
PSS Primary Tw4	4392	Float	4	R W	Second	1–20
PSS Primary T12	4394	Float	4	R W	Second	0.01–20
PSS Primary Kpe	4396	Float	4	R W	n/a	0–2
PSS Primary T13	4398	Float	4	R W	Second	0.05–20
PSS Primary Tr	4400	Float	4	R W	Second	0.01–1

Name	Register	Type	Bytes	R/W	Unit	Range
PSS Primary Supervisory Function Power-On Threshold	4402	Float	4	R W	n/a	0–1
PSS Primary Supervisory Function Power-On Hysteresis	4404	Float	4	R W	n/a	0–1
PSS Secondary M	4406	Uint32	4	R W	n/a	1–5
PSS Secondary N	4408	Uint32	4	R W	n/a	0–1
PSS Secondary Switch 0	4410	Uint32	4	R W	n/a	Disabled=0 Enabled=1
PSS Secondary Switch 1	4412	Uint32	4	R W	n/a	Disabled=0 Enabled=1
PSS Secondary Switch 3	4414	Uint32	4	R W	n/a	Frequency=0 Der. Speed=1
PSS Secondary Switch 4	4416	Uint32	4	R W	n/a	Power=0 Der. Freq/Speed=1
PSS Secondary Switch 5	4418	Uint32	4	R W	n/a	Exclude=0 Include=1
PSS Secondary Switch 6	4420	Uint32	4	R W	n/a	Disabled=0 Enabled=1
PSS Secondary Switch 7	4422	Uint32	4	R W	n/a	Off=0 On=1
PSS Secondary Switch 8	4424	Uint32	4	R W	n/a	Disabled=0 Enabled=1
PSS Secondary Switch 9	4426	Uint32	4	R W	n/a	Exclude=0 Include=1
PSS Secondary Switch 10	4428	Uint32	4	R W	n/a	Disabled=0 Enabled=1
PSS Secondary Switch 11	4430	Uint32	4	R W	n/a	Disabled=0 Enabled=1
PSS Secondary Tw1	4432	Float	4	R W	Second	1–20
PSS Secondary Tw2	4434	Float	4	R W	Second	1–20
PSS Secondary H	4436	Float	4	R W	n/a	0.01–25
PSS Secondary T11	4438	Float	4	R W	Second	0–20
PSS Secondary T1	4440	Float	4	R W	Second	0.001–6
PSS Secondary T2	4442	Float	4	R W	Second	0.001–6
PSS Secondary T3	4444	Float	4	R W	Second	0.001–6
PSS Secondary T4	4446	Float	4	R W	Second	0.001–6
PSS Secondary T5	4448	Float	4	R W	Second	0.001–6
PSS Secondary T6	4450	Float	4	R W	Second	0.001–6
PSS Secondary T7	4452	Float	4	R W	Second	0.001–6
PSS Secondary T8	4454	Float	4	R W	Second	0.001–6
PSS Secondary Terminal Voltage Limiter Time Constant	4456	Float	4	R W	Second	0.02–5
PSS Secondary Terminal Voltage Limiter Setpoint	4458	Float	4	R W	n/a	0–10
PSS Secondary Zeta Num 1	4460	Float	4	R W	n/a	0–1
PSS Secondary Zeta Den 1	4462	Float	4	R W	n/a	0–1
PSS Secondary Wn 1	4464	Float	4	R W	n/a	10–150
PSS Secondary Zeta Num 2	4466	Float	4	R W	n/a	0–1
PSS Secondary Zeta Den 2	4468	Float	4	R W	n/a	0–1
PSS Secondary Wn 2	4470	Float	4	R W	n/a	10–150
PSS Secondary Logic Output Limiter Upper Limit	4472	Float	4	R W	n/a	0.01–0.04
PSS Secondary Logic Output Limiter Lower Limit	4474	Float	4	R W	n/a	-0.040 – -0.010
PSS Secondary Logic Output Limiter Time Delay	4476	Float	4	R W	n/a	0–2
PSS Secondary Logic Limiter Washout Filter Normal Time	4478	Float	4	R W	n/a	5–0
PSS Secondary Logic Limiter Washout Filter Limit Time	4480	Float	4	R W	n/a	0–1

Name	Register	Type	Bytes	R/W	Unit	Range
PSS Secondary Stabilizer Gain Ks	4482	Float	4	R W	n/a	-100 – 100
PSS Secondary Output Limiting Upper Limit	4484	Float	4	R W	n/a	0–0.5
PSS Secondary Output Limiting Lower Limit	4486	Float	4	R W	n/a	-0.5 – 0
PSS Secondary Xq	4488	Float	4	R W	n/a	0–5
PSS Secondary Power Level Threshold	4490	Float	4	R W	n/a	0–1
PSS Secondary Power Level Hysteresis	4492	Float	4	R W	n/a	0–1
PSS Secondary Tw3	4494	Float	4	R W	Second	1– 20
PSS Secondary Tw4	4496	Float	4	R W	Second	1–20
PSS Secondary TI2	4498	Float	4	R W	Second	0.01–20
PSS Secondary Kpe	4500	Float	4	R W	n/a	0–2
PSS Secondary TI3	4502	Float	4	R W	Second	0.05– 20
PSS Secondary Tr	4504	Float	4	R W	Second	0.01–1
PSS Enable Status	4506	Uint32	4	R	n/a	Off=0 On=1

Grid Code Settings

Table 25-15. Grid Code Settings Group Parameters

Name	Register	Type	Bytes	R/W	Unit	Range
Grid Code Enable	4800	Uint32	4	R W	n/a	Disabled=0 Enabled=1
Grid Disconnect Time Delay	4802	Float	4	R W	Second	0–3600
Min Freq Normal	4804	Float	4	R W	Hertz	40–70
Max Freq Normal	4806	Float	4	R W	Hertz	40–70
Min V Bus Normal	4808	Float	4	R W	Per Unit	0.1–1
Max V Bus Normal	4810	Float	4	R W	Per Unit	1–1.3
Min Freq Disconnect	4812	Float	4	R W	Hertz	40–70
Max Freq Disconnect	4814	Float	4	R W	Hertz	40–70
Min V Bus Disconnect	4816	Float	4	R W	Per Unit	0.1–1
Max V Bus Disconnect	4818	Float	4	R W	Per Unit	1–1.3
PF Reference	4820	Float	4	R W	Power Factor	-1 – 1
Q Limit U Point 1	4822	Float	4	R W	Per Unit	0.8–1.2
Q Limit U Point 2	4824	Float	4	R W	Per Unit	0.8–1.2
Q Limit U Point 3	4826	Float	4	R W	Per Unit	0.8–1.2
Q Limit U Point 4	4828	Float	4	R W	Per Unit	0.8–1.2
Q Limit Q Point 1	4830	Float	4	R W	Per Unit	-0.4 – 0.4
Q Limit Q Point 2	4832	Float	4	R W	Per Unit	-0.4 – 0.4
Q Limit Q Point 3	4834	Float	4	R W	Per Unit	-0.4 – 0.4
Q Limit Q Point 4	4836	Float	4	R W	Per Unit	-0.4 – 0.4
Q(U) Slope	4838	Float	4	R W	Per Unit	0–20
Q(U) V Bus for Zero Q	4840	Float	4	R W	Per Unit	0.9–1.1
Q(U) Deadband	4842	Float	4	R W	Per Unit	0–0.1
Q(U) Max	4844	Float	4	R W	Per Unit	-0.4 – 0.4
Q(U) Min	4846	Float	4	R W	Per Unit	-0.4 – 0.4
Q(P) Point P01	4848	Float	4	R W	Per Unit	0–1.5
Q(P) Point P02	4850	Float	4	R W	Per Unit	0–1.5
Q(P) Point P03	4852	Float	4	R W	Per Unit	0–1.5
Q(P) Point P04	4854	Float	4	R W	Per Unit	0–1.5
Q(P) Point P05	4856	Float	4	R W	Per Unit	0–1.5
Q(P) Point P06	4858	Float	4	R W	Per Unit	0–1.5

Name	Register	Type	Bytes	R/W	Unit	Range
Q(P) Point P07	4860	Float	4	R W	Per Unit	0–1.5
Q(P) Point P08	4862	Float	4	R W	Per Unit	0–1.5
Q(P) Point P09	4864	Float	4	R W	Per Unit	0–1.5
Q(P) Point P10	4866	Float	4	R W	Per Unit	0–1.5
Q(P) Point Q01	4868	Float	4	R W	Per Unit	-0.7 – 0.7
Q(P) Point Q02	4870	Float	4	R W	Per Unit	-0.7 – 0.7
Q(P) Point Q03	4872	Float	4	R W	Per Unit	-0.7 – 0.7
Q(P) Point Q04	4874	Float	4	R W	Per Unit	-0.7 – 0.7
Q(P) Point Q05	4876	Float	4	R W	Per Unit	-0.7 – 0.7
Q(P) Point Q06	4878	Float	4	R W	Per Unit	-0.7 – 0.7
Q(P) Point Q07	4880	Float	4	R W	Per Unit	-0.7 – 0.7
Q(P) Point Q08	4882	Float	4	R W	Per Unit	-0.7 – 0.7
Q(P) Point Q09	4884	Float	4	R W	Per Unit	-0.7 – 0.7
Q(P) Point Q10	4886	Float	4	R W	Per Unit	-0.7 – 0.7
Remote Control Fail Mode	4888	Uint32	4	R W	n/a	Q(PF) Control=0 Hold Value=1
Remote Failure Time Delay	4890	Float	4	R W	Second	0–600
APC Enabled	4892	Uint32	4	R W	n/a	Disabled=0 Enabled=1
Active Power Input Source	4894	Uint32	4	R W	n/a	Active Power Setpoint=0 Active Power Selection=1
Active Power Setpoint	4896	Float	4	R W	Per Unit	-2 – 2
APC Normal Power Increase Rate Percent	4898	Float	4	R W	Percent Per Second	0.07–10
APC Normal Power Decrease Rate Percent	4900	Float	4	R W	Percent Per Second	0.07–10
LVRT Option	4902	Uint32	4	R W	n/a	Disabled=0 Q(PF) Control=1 Q(Voltage Limit) Control=2 Q(U) Control=3 Q(P) Control=4 Q Remote Control=5
LVRT Enabled	4904	Uint32	4	R W	n/a	Disabled=0 Enabled=1
Time Constant for PT1	4906	Float	4	R W	Second	0.01–60
LFSM Enabled	4908	Uint32	4	R W	n/a	Disabled=0 Enabled=1
LFSM U Deadband	4910	Float	4	R W	Hertz	40–70
LFSM O Deadband	4912	Float	4	R W	Hertz	40–70
LFSM U Max Power Limit Derate Percent	4914	Float	4	R W	Percent Per Hertz	0–20
LFSM O Max Power Limit Derate Percent	4916	Float	4	R W	Percent Per Hertz	0–20
LFSM U Droop Percent	4918	Float	4	R W	Percent Per Hertz	16.67–100
LFSM O Droop Percent	4920	Float	4	R W	Percent Per Hertz	16.67–100
APC Kg	4922	Float	4	R W	n/a	0–100
APC Ki	4924	Float	4	R W	n/a	0–100
APC PI Controller Max Limit	4926	Float	4	R W	Per Unit	-2 – 2
APC PI Controller Min Limit	4928	Float	4	R W	Per Unit	-2 – 2
Q(Third Party) Reference	4930	Float	4	R W	n/a	-0.45 – 0.45
Voltage Disconnect Time Delay	4932	Float	4	R W	Second	1–3600
Frequency Disconnect Time Delay	4934	Float	4	R W	Minute	1–60
Voltage Bus Time Constant	4936	Float	4	R W	Second	0.01–60
Q P Time Constant	4938	Float	4	R W	Second	0.01–60
Min Active Power Setpoint	4940	Float	4	R W	Per Unit	-2 – 2
Max Active Power Setpoint	4942	Float	4	R W	Per Unit	-2 – 2

Name	Register	Type	Bytes	R/W	Unit	Range
PF Gain	4944	Float	4	R W	n/a	-100 – 100
Q Limit Gain	4946	Float	4	R W	n/a	-100 – 100
Q U Gain	4948	Float	4	R W	n/a	-100 – 100
Q Remote Gain	4950	Float	4	R W	n/a	-100 – 100
Q Limit Q Reference	4952	Float	4	R W	Per Unit	-0.45 – 0.45
Grid Reconnect Stability Timer	4954	Float	4	R W	Minute	0–30
Min Frequency Reconnect	4956	Float	4	R W	Hertz	40–70
Max Frequency Reconnect	4958	Float	4	R W	Hertz	40–70
Min V Bus Reconnect	4960	Float	4	R W	Per Unit	0.1–1
Max V Bus Reconnect	4962	Float	4	R W	Per Unit	1–1.3
Recovery Time LFSM	4964	Float	4	R W	Minute	0.1–90
Recovery Power Increase Rate Percent	4966	Float	4	R W	Percent Per Second	0.001–10
Recovery Power Decrease Rate Percent	4968	Float	4	R W	Percent Per Second	0.001–10
Reserved	4970-74					
Active Power Level 1	4976	Float	4	R W	Per Unit	-2 – 2
Active Power Level 2	4978	Float	4	R W	Per Unit	-2 – 2
Active Power Level 3	4980	Float	4	R W	Per Unit	-2 – 2
Active Power Level 4	4982	Float	4	R W	Per Unit	-2 – 2
LFSM U Max Power Limit Start Frequency	4984	Float	4	R W	Hertz	40–70
LFSM O Max Power Limit Start Frequency	4986	Float	4	R W	Hertz	40–70
LFSM Power Increase Rate Percent	4988	Float	4	R W	Percent Per Second	0.33–10
LFSM Power Decrease Rate Percent	4990	Float	4	R W	Percent Per Second	0.33–10
APC Gain	4992	Float	4	R W	n/a	-100 – 100
Q Volt Limit Adjust Source	4994	Uint32	4	R W	n/a	None=0 Auxiliary Input=1 Modbus=2
Q U Adjust Source	4996	Uint32	4	R W	n/a	None=0 Auxiliary Input=1 Modbus=2
PF Adjust Source	4998	Uint32	4	R W	n/a	None=0 Auxiliary Input=1 Modbus=2
Q Third Party Adjust Source	5000	Uint32	4	R W	n/a	None=0 Auxiliary Input=1 Modbus=2
Active Power Adjust Source	5002	Uint32	4	R W	n/a	None=0 Auxiliary Input=1 Modbus=2
Reserved	5004					
Q Volt Limit Adjust Modbus	5006	Float	4	R W	Per Unit	-0.45 – 0.45
Q U Volt Bus for Zero Q Adjust Modbus	5008	Float	4	R W	n/a	-0.5 – 0.5
PF Reference Adjust Modbus	5010	Float	4	R W	Power Factor	-1 – 1
Q Third Party Adjust Modbus	5012	Float	4	R W	Per Unit	-0.45 – 0.45
Active Power Adjust Modbus	5014	Float	4	R W	Per Unit	-2 – 2
APC Bridge Enable	5016	Uint32	4	R W	n/a	Disabled=0 Enabled=1
LVRT Bridge Enable	5018	Float	4	R W	n/a	Disabled=0 Enabled=1
PF Active Power Level	5020	Float	4	R W	Per Unit	0–1

26 • Maintenance

Warning!

These servicing instructions are for use by qualified personnel only. To reduce the risk of electric shock, do not perform any servicing other than that specified in the operating instructions unless you are qualified to do so.

Before performing any maintenance procedures, remove the DECS-150 from service. Refer to the appropriate site schematics to ensure that all steps have been taken to properly and completely de-energize the DECS-150.

Preventive Maintenance

Connections

Periodically check the connections of the DECS-150 to ensure they are clean and tight and remove any accumulation of dust.

Electrolytic Capacitors

The DECS-150 contains long-life aluminum electrolytic capacitors. For a DECS-150 kept in storage as a spare, the life of these capacitors can be maximized by energizing the device for 30 minutes once per year.

To energize the device, apply operating power within one of the following ranges:

- 100 to 139 Vac, or 125 Vdc
- 190 to 277 Vac, or 250 Vdc

Caution

When energizing the DECS-150 from a low impedance source (such as a wall outlet), use of an Inrush Current Reduction Module (ICRM-7) is recommended to prevent damage to the DECS-150. For a detailed description of the Inrush Current Reduction Module, refer to Basler publication 9387900990. ICRM-7 connections are illustrated in *Typical Connections*.

Cleaning the Front Panel

Only a soft cloth and water-based solutions should be used to clean the front panel. Do not use solvents.

Storage

If the DECS-150 is not installed immediately, store it in the original shipping package in a moisture- and dust-free environment.



27 • Troubleshooting

The following troubleshooting procedures assume the excitation system components are properly matched, fully operational, and correctly connected. If you do not obtain the results that you expect from the DECS-150, first check the programmable settings for the appropriate function.

Communications

BESTCOMSPlus Metering Incorrect

If power factor, var, or watt readings are significantly different from the expected readings for a known load, verify that the B-phase current sensing input of the DECS-150 is connected to a CT on phase B and not phases A or C.

No Communication

If communication with the DECS-150 cannot be initiated, check the connections at the communication ports.

No Communication Through the USB Port

A failure to establish communication through the USB port may be caused by a failure of the automatic installation of the DECS-150 USB driver in Windows®. This condition is indicated by a Driver Software Installation error message. To install the DECS-150 USB driver manually, perform the following steps.

Step 1: Open the Windows Device Manager. Under Other Devices, right-click on DECS-150 (or Unknown Device) and select Properties.

Step 2: In the Properties window, select the Driver tab and click the Update Driver button.

Step 3: Select "Browse my computer for driver software" and then navigate to:

C:\Program Files\Basler Electric\USB Device Drivers\USBIO

Install the USB driver software. Successful installation will be indicated by a confirmation message.

General Operation

Machine Voltage Does Not Build

Step 1: Verify that all wiring is properly connected. Refer to the *Typical Connections* section.

If wiring is improperly connected or loose, reconnect wiring properly.

If wiring connections are correct, proceed to Step 2.

Step 2: Verify that the machine is spinning at rated speed.

If the machine is not up to rated speed, increase machine speed to the rated value.

If the machine is spinning at rated speed, proceed to Step 3.

Step 3: For PMG power, check for correct input power to the DECS-150. Refer to the *Specifications* section for input power requirements.

If voltage is not present, refer to the machine manual for repair procedures (PMG system only).

If voltage is present, proceed to Step 4.

Step 3a: If the DECS-150 is being shunt powered (non-PMG) mode, verify that the residual voltage applied to the power input is at least 6 Vac.

If the applied voltage is less than 6 Vac, refer to the machine manual and flash the machine field.

If the applied voltage is 6 Vac or greater, proceed to Step 4.

Step 4: Verify that no fuses are open.

Replace any open fuses.

If no fuses are open, proceed to Step 5.

Step 5: Verify that the machine is not shut down through BESTlogic*Plus*.

Step 6: Verify that the front panel Overexcitation indicator is not lit.

If the front panel Overexcitation indicator (field voltage) is lit, check the machine and/or load conditions. Interrupt input power or shut down the machine for a minimum of one minute.

If the front panel Overexcitation indicator is not lit, proceed to Step 7.

Step 7: Verify that the front panel Overexcitation Limiting indicator is not lit.

If the front panel Overexcitation Limiting indicator is lit, check the machine and load conditions. Also check the Field Current Limit setpoint for the correct level. Interrupt input power or shut down the machine for a minimum of 1 minute.

If the front panel Overexcitation Limiting indicator is not lit, proceed to Step 8.

Step 8: Verify that the DECS-150 soft start settings are correct. Too long of a soft start setting may give the appearance of no buildup.

If the soft start settings are incorrect, adjust the settings.

If the soft start settings have no effect, proceed to Step 9.

Step 9: Replace the DECS-150 unit.

If replacing the DECS-150 unit does not correct the malfunction, then the machine is defective. Consult with the machine manufacturer.

Low Machine Output Voltage

Step 1: Verify that the voltage adjustment is not set too low.

If the voltage adjustment is too low, adjust it to the correct setpoint.

If the voltage adjustment is correct, proceed to Step 2.

Step 2: Verify that the Underfrequency Knee setpoint is not greater than the machine frequency.

If the Underfrequency setpoint is too high, adjust the setpoint below the rated machine frequency.

If the Underfrequency setpoint is correct, proceed to Step 3.

Step 3: Verify that the machine is spinning at rated speed.

If the machine is not up to rated speed, increase the machine speed to the rated level.

If the machine is spinning at rated speed, proceed to Step 4.

Step 4: For PMG power, check for correct input power to the DECS-150. Refer to the *Specifications* section for input power requirements.

If the DECS-150 input voltage is low, refer to the PMG manual for PMG repair (PMG system only).

If the voltage is at the required level, proceed to Step 5.

Step 4a. If the DECS-150 is being shunt powered (non-PMG), verify that the power potential transformer (if used) has the correct turns ratio, is sized properly, and is supplying the correct voltage level to the power input.

If the turns ratio of the power potential transformer is incorrect, is sized too small, or is not supplying the correct input power, replace the power potential transformer.

If the power potential transformer is correct, proceed to Step 5.

Step 5. Verify that the sensing potential transformer (if used) has the correct turns ratio and is operating correctly.

If the turns ratio of the sensing potential transformer is incorrect, replace the sensing potential transformer.

If the sensing potential transformer is operating correctly, proceed to Step 6.

Step 6. Verify that the front panel Overexcitation Limiter Active indicator is not lit.

If the front panel Overexcitation Limiter Active indicator is lit, check the machine and/or load conditions. Also check the Field-Current Limit setpoint for the correct level. Interrupt input power or shut down the machine for a minimum of one minute.

If the front panel Overexcitation Limiter Active indicator is not lit, proceed to Step 7.

Step 7. Low machine output voltage may occur when operating in droop mode with an inductive load.

If the low voltage condition is not caused by the droop function, proceed to Step 8.

Step 8. Verify that the Voltage setpoint is not being modified by application of voltage or current to the Accessory Input.

If the low voltage condition is not caused by the Accessory Input, proceed to Step 9.

Step 9. Replace the DECS-150 unit.

High Machine Output Voltage

Step 1. Verify that the voltage adjustment is not set too high.

If the voltage adjustment is too high, adjust it to the correct setpoint.

If the voltage adjustment is correct, proceed to Step 2.

Step 2. Verify that the sensing potential transformer (if used) has the correct turns ratio.

If the turns ratio of the sensing potential transformer is incorrect, replace the sensing potential transformer with the correct one.

If the sensing potential transformer is correct, proceed to Step 3.

Step 3. High machine output voltage may occur when operating in droop mode with a capacitive load.

If the high voltage condition is not caused by the droop function, proceed to Step 4.

Step 4. High machine output voltage may occur when operating in line-drop compensation mode with a capacitive load.

If the high voltage condition is not caused by the line-drop compensation function, proceed to Step 5.

Step 5. Verify that the Voltage setpoint is not being modified by application of voltage or current to the Accessory Input.

If the high voltage condition is not caused by voltage applied to the Accessory Input, proceed to Step 6.

Step 6. Replace the DECS-150 unit.

Poor Voltage Regulation

Step 1. Verify that the DECS-150 is properly grounded.

If the DECS-150 is not properly grounded, connect a dedicated ground wire to the terminal labeled GND on the DECS-150.

If the DECS-150 is properly grounded, proceed to Step 2.

Step 2. Check for grounded field leads.

If the field leads are grounded, isolate them from ground.

If the field leads are not grounded, proceed to Step 3.

Step 3. If the DECS-150 is powered from a PMG, check for grounded PMG leads.

If the PMG leads are grounded, isolate them from ground.

If the PMG leads are not grounded, proceed to Step 4.

Step 4. Verify that the machine frequency is not dropping below the DECS-150 Underfrequency setpoint when load is applied to the machine.

If the machine frequency is dropping below the Underfrequency setpoint, reduce the setpoint if possible. Also check the prime mover and machine for proper sizing in relation to the applied load.

If poor regulation is not related to DECS-150 underfrequency operation, proceed to Step 5.

Step 5. Verify that regulation is not being affected by normal droop operation.

If droop operation is not affecting regulation, proceed to Step 6.

Step 6. Replace the DECS-150 unit.

Machine Output Unstable (Hunting)

Step 1. Verify that the governor for the prime mover is operating properly.

If the governor is not operating properly, troubleshoot using the manufacturer's suggested procedures.

If the governor is operating properly, proceed to Step 2.

Step 2. Verify that the sensing and input power leads are connected securely.

If the sensing or input power leads are not connected securely, tighten the connections.

If the sensing or input power lead connections are secure, proceed to Step 3.

Step 3. Verify that the DECS-150 AVR gains are set properly.

If the gain settings are incorrect, reset the gains.

Overexcitation Indicator is Annunciating

Step 1. Check for machine overloading.

If the machine is operating with a larger than rated load, shed load.

If the machine is operating with a rated or less than rated load, proceed to Step 2.

Step 2. Verify that the machine exciter field voltage requirements are compatible with the DECS-150.

If the exciter field voltage requirements are not compatible with the DECS-150, contact Basler Electric Customer Service for recommendations.

If the exciter field voltage requirements are compatible with the DECS-150, proceed to Step 3.

Step 3. Replace the DECS-150.

If replacing the DECS-150 does not correct the malfunction, proceed to Step 4.

Step 4. Refer to the machine manual. Machine is defective.

Loss of Machine Sensing Indicator is Annunciating

Step 1. Verify that the voltage sensing leads are properly connected.

If the sensing leads are not properly connected, correct the connections.

If the sensing lead connections are correct, proceed to Step 2.

Step 2. For single-phase sensing, verify that E1 and E3 are connected.

If E1 and E3 are not connected, connect them as required.

If E1 and E3 are properly connected, proceed to Step 3.

Step 3. Verify that the sensing potential transformer (if used) has the correct turns ratio and is functioning properly.

If the sensing potential transformer has the wrong turns ratio or is malfunctioning, replace it.

If the sensing potential transformer is correct and functioning properly, proceed to Step 4.

Step 4. Verify that the machine output voltage is present on all phases.

If the machine is missing a phase, refer to the machine manual. Machine is defective.

If machine output voltage is balanced on all phases, proceed to Step 5.

Step 5. Replace the DECS-150.

Overexcitation Limiting Indicator is Annunciating

Step 1. Check for machine overloading.

If the machine is operating with a larger than rated load, shed load.

If the machine is operating with a rated or less than rated load, proceed to Step 2.

Step 2. Verify that the DECS-150 output (field) current limit is not set too low.

If the Output Current Limit setpoint is too low, adjust for the proper setting.

If the output current limit is set properly, proceed to Step 3.

Step 3. Verify that the machine exciter field current requirements are compatible with the DECS-150.

If the machine exciter field current requirements are not compatible with the DECS-150, contact Basler Electric Customer Service for recommendations.

If the machine exciter field current requirements are compatible with the DECS-150, proceed to Step 4.

Step 4. Replace the DECS-150.

If replacing the DECS-150 does not correct the malfunction, proceed to Step 5.

Step 5. Refer to the machine manual. Machine is defective.

Underexcitation Limiting Indicator is Annunciating

Step 1. Verify that the DECS-150 Machine Voltage setpoint is not being driven to a lower level.

The setpoint can be affected by the Raise/Lower contact inputs or by the Auxiliary input.

Step 2. Verify that the DECS-150 output (field) current limit is not set too low.

Adjust the field current limit as needed.

Step 3. Use the connection diagrams of the *Typical Connections* section to verify that the sensing voltage and current connections to the DECS-150 provide the proper phasing.

Correct the sensing voltage and current connections as needed.

Step 4. Verify that the machine exciter field current requirements are compatible with the DECS-150.

If the machine exciter field current requirements are not compatible with the DECS-150, contact Basler Electric Technical Sales Support for recommendations.

If the machine exciter field current requirements are compatible with the DECS-150, proceed to Step 5.

Step 5. Replace the DECS-150.

If replacing the DECS-150 does not correct the malfunction, proceed to Step 6.

Step 6. Refer to the machine manual or contact the machine manufacturer.

Underfrequency Active Indicator is Annunciating

Step 1. Verify that the machine is operating at rated speed.

If the machine is not operating at rated speed, adjust the machine speed.

If the machine is operating at the rated speed, proceed to Step 2.

Step 2. Verify that the Underfrequency setpoint is correct.

If the Underfrequency setpoint is incorrect, adjust it to the correct value.

No Droop

Step 1. Verify that the DECS-150 52L/M contact input is open.

If the 52L/M contact input is not open, it must be opened to enable the droop function.

If the 52L/M contact input is open, proceed to Step 2.

Step 2. Verify that the DECS-150 52J/K contact input (if present) is closed or the Var/PF function is disabled via *BESTCOMSPlus*. Var/PF operation must be disabled for droop operation. If var/PF operation is disabled, proceed to Step 3.

Step 3. Verify that the DECS-150 droop setting is not adjusted to 0% droop.

If the droop setting is adjusted to 0% droop, increase the setpoint above 0%.

If the droop setting is adjusted to above 0%, proceed to Step 4.

Step 4. Check for an open in the circuit connected to DECS-150 CT1 and CT2.

If there is an open circuit, repair as necessary.

If there is no open circuit, proceed to Step 5.

Step 5. Verify that all connections are correct. Refer to the *Typical Connections* section.

If connections are incorrect, correct the problem.

If connections are correct, proceed to Step 6.

Step 6. Verify that droop is not disabled through *BESTlogicPlus*.

Step 7. Verify that the load applied to the generator for droop testing is not purely resistive.

If only a resistive load is being applied to the generator, apply an inductive load and retest.

If the load being to the generator is inductive, proceed to Step 8.

Step 8. Verify that your DECS-150 is compatible with the current sensing transformer (1 A or 5 A secondary) being used. For example, a current sensing transformer with a 1 ampere output rating would produce very little droop if the DECS-150 has a 5 ampere current transformer input. To check the current transformer input of your DECS-150, refer to the style chart in the *Introduction* section.

If the current transformer input is incorrect, replace the current sensing transformer or the DECS-150 for compatibility.

If the current transformer input is correct, proceed to Step 9.

Step 9. If the above steps fail to correct the malfunction, replace the DECS-150 unit.

No Voltage Matching

Step 1. Verify that Voltage Matching is enabled in BESTCOMSP*lus* software.

If not enabled, use the software to turn on voltage matching.

If voltage matching is enabled, proceed to Step 2.

Step 2. Verify that all connections are correct according to the *Typical Connections* section as required for voltage matching.

If the interconnection is incorrect, reconnect according to the appropriate interconnect diagram.

If the interconnection is correct, proceed to Step 3.

Step 3. Verify that voltage matching is not disabled through BESTlogic*Plus*.

If voltage matching is not disabled, proceed to Step 2.

Step 4. Check for correct utility reference voltage on DECS-150 terminals B1 and B3.

If the interconnection is incorrect, reconnect according to the appropriate interconnect diagram.

If the interconnection is correct, check for open system fuses.

Verify that the potential sensing transformer, if used, is connected to DECS-150 terminals B1 and B3.

If potential sensing transformer connections are correct, proceed to Step 5.

Step 5. Verify that the Machine Output Voltage setpoint is within 10 percent of the measured utility bus voltage.

If the setpoint is too low or too high, adjust the setpoint to the appropriate level.

If the setpoint is correct, proceed to Step 6.

Step 6. If the above steps fail to correct the voltage matching malfunction, replace the DECS-150.

Support

Contact the Basler Electric Technical Services Department at +1.618.654.2341 for troubleshooting support or to receive a return authorization number.



28 • Specifications

DECS-150 Digital Excitation Control Systems have the following features and capabilities.

Operating Power

Voltage Range

For 63 Vdc Excitation Power 100 to 139 Vac or 125 Vdc

For 125 Vdc Excitation Power ... 190 to 277 Vac single-phase, 190 to 260 Vac three-phase,
or 250 Vdc

Frequency Range..... dc, 50 to 500 Hz

Power Dissipation 40 W maximum continuous

Table 28-1 lists the required nominal operating power voltage and configuration required to obtain 63 and 125 Vdc continuous field power for the DECS-150.

Table 28-1. Operating Power Requirements

Excitation Power	63 Vdc	125 Vdc
Input Power Configuration	1- or 3-phase	1- or 3-phase
Nominal Input Voltage	120 Vac/125 Vdc	240 Vac/250 Vdc
Full Load Continuous Voltage	63 Vdc	125 Vdc
Full Load Continuous Current at 70°C Ambient Temperature	7 A	
Full Load Continuous Current at 55°C Ambient Temperature	10 A	
Minimum Residual Voltage for Buildup	6 Vac	
Operating Power Input Burden at 7 Adc Excitation Output	698 VA 540 W	1,610 VA 1,025 W
Operating Power Input Burden at 10 Adc Excitation Output	980 VA 770 W	2,248 VA 1,475 W
Operating Temperature at 7 Adc Excitation Output	-40 to +70°C (-40 to +158°F)	
Operating Temperature at 10 Adc Excitation Output	-40 to +55°C (-40 to +131°F)	

Machine and Bus Voltage Sensing

Type 1-phase or 3-phase–3-wire

Nominal Input Voltage Range 100 to 600 Vac \pm 10%

Nominal Input Frequency 50 or 60 Hz

Burden..... <1 VA per phase

Terminals

Machine Voltage Sensing E1, E2, E3

Bus Voltage Sensing..... B1, B2, B3

Machine Current Sensing

Configuration.....	4 inputs: A-, B-, C-phase, and cross-current compensation CT input
Type	1-phase (B-phase), 1-phase with cross-current compensation, 3-phase, 3-phase with cross-current compensation
Range.....	1 Aac or 5 Aac nominal
Frequency	50/60 Hz

Burden

1 Aac Sensing	<0.1 VA
5 Aac Sensing	<0.3 VA

Terminals

A-Phase.....	IA+, IA-
B-Phase.....	IB+, IB-
C-Phase	IC+, IC-
Cross-Current Compensation	CC+, CC-

Accessory Inputs

Current Input

Range	4 to 20 mAdc
Burden	Approximately 150Ω
Terminals.....	I+, I-

Voltage Input

Range	-10 to +10 Vdc
Burden	Approximately 100 kΩ
Terminals.....	V+, V-

Contact Inputs

Type	Dry contact
Interrogation Voltage.....	12 Vdc

Terminals

Programmable Input 1.....	IN1, COM
Programmable Input 2.....	IN2, COM
Programmable Input 3.....	IN3, COM
Programmable Input 4.....	IN4, COM
Programmable Input 5.....	IN5, COM
Programmable Input 6.....	IN6, COM
Programmable Input 7.....	IN7, COM
Programmable Input 8.....	IN8, COM

Contact Outputs

Ratings

General Purpose	7 A, 24 Vdc/240 Vac
Pilot Duty	2 A, 240 Vac (The load must be in parallel with a diode rated at least three times the coil current and three times the coil voltage.)
Breaker Shunt Trip Output	100 mAdc

Terminal Assignments

Watchdog	WD1, WD2, WD3
Relay Output 1	OC1, OC1
Relay Output 2	OC2, OC2
Breaker Shunt Trip Output	ST+, ST-

Field Power Output

Continuous Rating	7 Adc (70°C ambient) or 10 Adc (55°C ambient)
Terminals	F+, F-

Minimum 10-Second Forcing Output Rating

120 Vac Input	100 Vdc, 11 Adc
240 Vac Input	200 Vdc, 11 Adc

Minimum Field Resistance

63 Vdc Application	9 Ω
125 Vdc Application	18 Ω

Regulation

In regulation modes that rely upon the monitoring of the generator terminal voltage and current, the DECS-150 senses and responds to the measured rms quantities.

FCR Operating Mode

Setpoint Range	0 to 7 Adc (70°C ambient) or 0 to 10 Adc (55°C ambient) in 0.1 Adc increments
Regulation Accuracy	$\pm 5.0\%$

AVR Operating Mode

Setpoint Range	70 to 120% of rated machine voltage, in increments of 0.1%
Regulation Accuracy	$\pm 0.25\%$ over load range at rated PF with constant machine frequency and ambient temperature
Steady-State Stability	$\pm 0.25\%$ at rated PF with constant machine frequency and ambient temperature
Temperature Drift	$\pm 0.5\%$ between 0 and 40°C at constant load and machine frequency

Var Operating Mode

Setpoint Range	-100% (leading) to +100% (lagging) of the machine nominal apparent power in increments of 0.1%
Regulation Accuracy	$\pm 2.0\%$ of the nominal machine apparent power rating at the rated machine frequency

Power Factor Operating Mode

Setpoint Range	0.5 to 1.0 (lagging) and -0.5 to -1.0 (leading), in increments of 0.01
Regulation Accuracy	± 0.02 PF of the PF setpoint for the real power between 10 and 100% at the rated frequency

Parallel Compensation

Modes Reactive Droop, Line Drop, and Reactive Differential (Cross-Current)

Cross-Current Input Burden	Can exceed 1 VA if external resistors are added to the CT circuit for cross-current compensation
----------------------------------	--------------------------------------------------------------------------------------------------

Cross-Current Input Terminals..... CC+, CC–

Setpoint Range

Reactive Droop 0 to +30% of Rated Voltage
 Line Drop 0 to 30% of Rated Voltage
 Cross-Current..... –30 to +30% of Primary CT Current

Machine Protection Functions

Overvoltage (59) and Undervoltage (27)

Pickup

Range 1 to 99,999 Vac
 Increment 1 Vac

Time Delay

Range 0.1 to 60 s
 Increment 0.1 s

Loss of Sensing

Time Delay

Range 0 to 30 s
 Increment 0.1 s

Voltage Balanced Level

Range 0 to 100% of Positive Sequence Voltage
 Increment 0.1%

Voltage Unbalanced Level

Range 0 to 100% of Positive Sequence Voltage
 Increment 0.1%

Overfrequency (81O) and Underfrequency (81U)

Pickup

Range 0 or 30 to 70 Hz
 Increment 0.01 Hz

Time Delay

Time Delay Range 0.1 to 300 s
 Increment 0.1 s

Voltage Inhibit (81U only)

Range 0 or 5 to 100% of Rated Voltage
 Increment 1%

Field Protection Functions

Field Overvoltage

Pickup

Range 0 or 1 to 300 Vdc
 Increment 1 Vdc

Time Delay

Range 0 to 30 s
 Increment 0.1 s

Exciter Diode Monitor (EDM)*Pickup*

Range 0 or 1 to 10 A

Increment 0.1 A

Delay

Range 0 or 0.2 to 30 s

Increment 0.1 s

Synchronism Check (25) Protection**Voltage Difference**

Range 0.1 to 50%

Increment 0.1%

Slip Angle

Range 1 to 99°

Increment 1°

Angle Compensation

Range 0 to 359°

Increment 0.1°

Slip Frequency

Range 0.01 to 0.5 Hz

Increment 0.01 Hz

Startup**PWM Startup Duty Cycle**

Range 0 to 100%

Increment 1%

Soft Start Level

Range 0 to 90% of Rated Gen Voltage

Increment 1%

Soft Start Time

Range 1 to 7,200 s

Increment 1 s

Voltage Matching

Accuracy..... Machine rms voltage is matched with the bus rms voltage to within $\pm 0.5\%$ of the machine voltage.

On-Line Overexcitation Limiting

High Current Level

Pickup

Range 0 to 11 Adc (70°C ambient) or 0 to 14 Adc (55°C ambient)

Increment 0.01 Adc

Time

Range 0 to 10 s

Increment 1 s

Medium Current Level

Pickup

Range 0 to 9 Adc (70°C ambient) or 0 to 12 Adc (55°C ambient)

Increment 0.01 Adc

Time

Range 0 to 120 s

Increment 1 s

Low Current Level

Pickup

Range 0 to 7 Adc (70°C ambient) or 0 to 10 Adc (55°C ambient)

Increment 0.01 Adc

Off-Line Overexcitation Limiting

High Current Level

Pickup

Range 0 to 11 Adc (70°C ambient) or 0 to 14 Adc (55°C ambient)

Increment 0.01 Adc

Time

Range: 0 to 10 s

Increment: 1 s

Low Current Level

Pickup

Range 0 to 7 Adc (70°C ambient) or 0 to 10 Adc (55°C ambient)

Increment 0.01 Adc

Sequence of Events Recording (SER)

See the *Reports* section.

Data Logging (Oscillography)

See the *Reports* section.

Real-Time Clock

Clock has leap year and selectable daylight saving time correction. Backup battery sustains timekeeping during losses of DECS-150 operating power.

Resolution 1 s

Clock Holdup

Battery Holdup Time Approximately 5 years depending on conditions
 Battery Type Rayovac BR2032, coin-type, 3 Vdc, 195 mAh,
 Basler Electric P/N 38526

Caution

Replacement of the backup battery for the real-time clock should be performed only by qualified personnel.

Do not short-circuit the battery, reverse battery polarity, or attempt to recharge the battery. Observe polarity markings on the battery socket while inserting a new battery. The battery polarity must be correct in order to provide backup for the real-time clock.

It is recommended that the battery be removed if the DECS-150 is to be operated in a salt-fog environment. Salt-fog is known to be conductive and may short-circuit the battery.

Note

Failure to replace the battery with Basler Electric P/N 38526 may void the warranty.

Communication Ports

Universal Serial Bus (USB)

Interface USB type B port
 Location Front panel (style xxS2V) or Rear panel (style xxS1V)

Caution

In accordance with the guidelines defined in USB standards, the USB port on this device is not isolated. To prevent damage to a connected PC or laptop, the DECS-150 must be properly tied to ground.

Ethernet

Type 10BASE-T/100BASE-TX copper
 Interface RJ45 jack
 Location Rear panel

Controller Area Network (CAN)

Type SAE J1939 message protocol
 Interface Spring type terminals
 Location Rear panel

Terminals..... CAN 2 H, L, SH
 Communication Rate..... 250 kb/s

Environment

Temperature

Operating Range

7 Adc Continuous –40 to +70°C (–40 to +158°F)

10 Adc Continuous –40 to +55°C (–40 to +131°F)

Storage Range –40 to +85°C (–40 to +185°F)

Humidity

Complies with MIL-STD-705B, Method 711-1C

Salt Fog

Complies with IEC 60068-2-11

Elevation

1,000 m (3,300 ft.) maximum

Ingress Protection

Front-Panel USB Port (Style xxS2V) IP42

Rear-Panel USB Port (Style xxS1V) IP54

Type Tests

Shock

Withstands 30 G in 3 perpendicular planes.

Vibration

18 to 2,000 Hz 5 G for 3 hours

Transients

EN61000-4-4

Static Discharge

EN61000-4-2

HALT (Highly Accelerated Life Testing)

HALT is used by Basler Electric to prove that our products will provide the user with many years of reliable service. HALT subjects the device to extremes in temperature, shock, and vibration to simulate years of operation, but in a much shorter period. HALT allows Basler Electric to evaluate all possible design elements that will add to the life of this device. As an example of some of the extreme testing conditions, the DECS-150 was subjected to temperature tests (tested over a temperature range of –90 to +130°C (–130 to +202°F)), vibration tests (of 5 to 50 G at +20°C (68°F)), and temperature/vibration tests (tested at 50 G over a temperature range of –80 to +120°C (–112 to +248°F)). Combined temperature and vibration testing at these extremes proves that the DECS-150 is expected to provide long-term operation in a rugged environment. Note that the vibration and temperature extremes listed in this paragraph are specific to HALT and do not reflect recommended operation levels.

Physical

Dimensions..... Refer to the *Mounting* section.
Weight 3.95 lb (1.79 kg)

Regulatory Certifications and Standards

Maritime Recognition

Recognized per standard IACS UR (sections E10 and E22) by the following:

- Bureau Veritas (BV)
- Det Norske Veritas (DNV)
- American Bureau of Shipping (ABS)

IEC 60092-504 used for evaluation.

For current certificates, see www.basler.com.

Grid Code Compliance

Component certified per standard VDE-AR-N 4110.

UL Approval

This product is recognized to applicable Canadian and US safety standards and requirements by UL.

Standard used for evaluation:

- UL 6200
- CSA C22.2 No. 14

Caution
To follow UL guidelines, replacement of the backup battery for the real-time clock should be performed only by qualified personnel.

CSA Certification

This product was tested and has met the certification requirements for electrical, plumbing, and/or mechanical products. CSA Report (1148123)

Standards used for evaluation:

- UL 508
- CSA C22.2 No. 0
- CSA C22.2 No. 14

CE Compliance

This product has been evaluated and complies with the relevant essential requirements set forth by the EU legislation.

EC Directives:

- LVD 2014/35/EU
- EMC 2014/30/EU
- RoHS 2 2011/65/EU

Harmonized standards used for evaluation:

- EN 50178 – *Electronic Equipment for Use in Power Installations*
- EN 61000-6-4 – *Electromagnetic Compatibility (EMC), Generic Standards, Emission Standard for Industrial Environments*

- EN 61000-6-2 – *Electromagnetic Compatibility (EMC), Generic Standards, Immunity for Industrial Environments*

UK Conformity Assessed (UKCA)

This product was evaluated and complies with all applicable UK Parliament and CE directives required for products sold within Great Britain.

Harmonized standards applied:

- EN 50178 – *Electronic Equipment for Use in Power Installations*
- EN 61000-6-2 – *Electromagnetic Compatibility (EMC), Generic Standards, Immunity for Industrial Environments*
- EN 61000-6-4 – *Electromagnetic Compatibility (EMC), Generic Standards, Emission Standard for Industrial Environments*
- IEC 60092 – *Electrical Installation in Ships, Part 504: Automation Control and Instrumentation*

China RoHS

The following table serves as the declaration of hazardous substances for China in accordance with PRC standard SJ/T 11364-2014. The EFUP (Environment Friendly Use Period) for this product is 40 years.

PRODUCT: DECS-150										
零件名称 Part Name	有害物质 Hazardous Substances									
	铅 Lead (Pb)	汞 Mercury (Hg)	镉 Cadmium (Cd)	六价铬 Hexavalent Chromium (Cr ⁶⁺)	多溴联苯 Polybrominated Biphenyls (PBB)	多溴二苯醚 Polybrominated Diphenyl Ethers (PBDE)	邻苯二甲酸二丁酯 Dibutyl Phthalate (DBP)	邻苯二甲酸丁苄酯 Benzyl butyl phthalate (BBP)	邻苯二甲酸二乙酯 Bis(2-ethylhexyl) phthalate (BEHP)	邻苯二甲酸二异丁酯 Diisobutyl phthalate (DIBP)
金属零件 Metal parts	O	O	O	O	O	O	O	O	O	O
聚合物 Polymers	O	O	O	O	O	O	O	O	O	O
电子产品 Electronics	X	O	O	O	O	O	O	O	O	O
电缆和互连配件 Cables & interconnect accessories	O	O	O	O	O	O	O	O	O	O
绝缘材料 Insulation material	O	O	O	O	O	O	O	O	O	O

本表格依据 SJ/T11364 的规定编制。

O: 表示该有害物质在该部件所有均质材料中的含量均在 GB/T 26572 规定的限量要求以下。

X: 表示该有害物质至少在该部件的某一均质材料中的含量超出 GB/T 26572 规定的限量要求。

This form was prepared according to the provisions of standard SJ/T11364.

O: Indicates that the hazardous substance content in all homogenous materials of this part is below the limit specified in standard GB/T 26252.

X: Indicates that the hazardous substance content in at least one of the homogenous materials of this part exceeds the limit specified in standard GB/T 26572.

Patent

Basler Electric. Digital Excitation Control Systems Utilizing Self-Tuning PID Gains and an Associated Method of Use. US Patent 20090195224, filed January 31, 2008 and issued August 6, 2009.

29 • BESTCOMSP^{Plus}® Settings Loader Tool

The BESTCOMSP^{Plus}® Settings Loader Tool is a software application, which allows the user to instantly upload settings to Basler BESTCOMSP^{Plus}-compatible products by scanning a pre-registered bar code, which promotes consistency, reduces potential errors, and saves time.

Setup

The BESTCOMSP^{Plus} Settings Loader Tool software and a bar code reader (acquired separately) must be installed on the same PC.

BESTCOMSP^{Plus} Settings Loader Tool Installation

System Recommendations

The BESTCOMSP^{Plus}® Settings Loader Tool is bundled with BESTCOMSP^{Plus} software. BESTCOMSP^{Plus} software is built on the Microsoft® .NET Framework. The setup utility that installs BESTCOMSP^{Plus} on your PC also installs the BESTCOMSP^{Plus} Settings Loader Tool and the required version of .NET Framework (if not already installed). BESTCOMSP^{Plus} operates with systems using Windows® 7 SP1, Windows 8.1, Windows 10 version 1607 (Anniversary Edition) or later, and Windows 11. System recommendations for the .NET Framework and BESTCOMSP^{Plus} are listed in Table 29-1.

Table 29-1. System Recommendations for BESTCOMSP^{Plus} and the .NET Framework

System Type	Component	Recommendation
32/64 bit	Processor	2.0 GHz
32/64 bit	RAM	1 GB (minimum), 2 GB (recommended)
32/64 bit	Hard Drive	200 MB (if .NET Framework is already installed on PC)
		4.5 GB (if .NET Framework is not already installed on PC)

To install and run BESTCOMSP^{Plus}, a Windows user must have Administrator rights.

Installation

Note

Do not connect a USB cable until setup completes successfully. Connecting a USB cable before setup is complete may result in unwanted or unexpected errors.

1. Download BESTCOMSP^{Plus} from www.basler.com.
2. Click the installation button for BESTCOMSP^{Plus}. The setup utility installs BESTCOMSP^{Plus}, the .NET Framework (if not already installed), the USB driver, and the DECS-150 plugin for BESTCOMSP^{Plus} on your PC.

When BESTCOMSP^{Plus} installation is complete, a Basler Electric folder is added to the Windows programs menu. This folder is accessed by clicking the Windows Start button and then accessing the Basler Electric folder in the Programs menu. The Basler Electric folder contains an icon that starts the BESTCOMSP^{Plus} Settings Loader Tool.

Bar Code Reader and Bar Codes

The BESTCOMSP^{Plus}® Settings Loader Tool is compatible with bar code readers, which conform to UnifiedPOS specifications. Bar code readers and bar code labels are not provided and must be acquired separately. Refer to the bar code reader's documentation for installation instructions.

Any bar code compatible with your bar code reader may be used.

BESTCOMSPPlus® Settings Loader Tool Settings

BESTCOMSPPlus Settings Loader Tool settings are found on two main screens, the *Loader Grid* and *Configuration* screen. The Loader Grid contains management options for the product settings files and their associated bar codes. The Configuration screen contains product-specific options for the default behavior of the BESTCOMSPPlus Settings Loader Tool. These settings are described in the following paragraphs.

Loader Grid

One entry, or row, in the Loader Grid contains all of the necessary data to associate a product settings file with a bar code. New entries can be added. Existing entries can be edited, deleted, and uploaded to a Basler product.

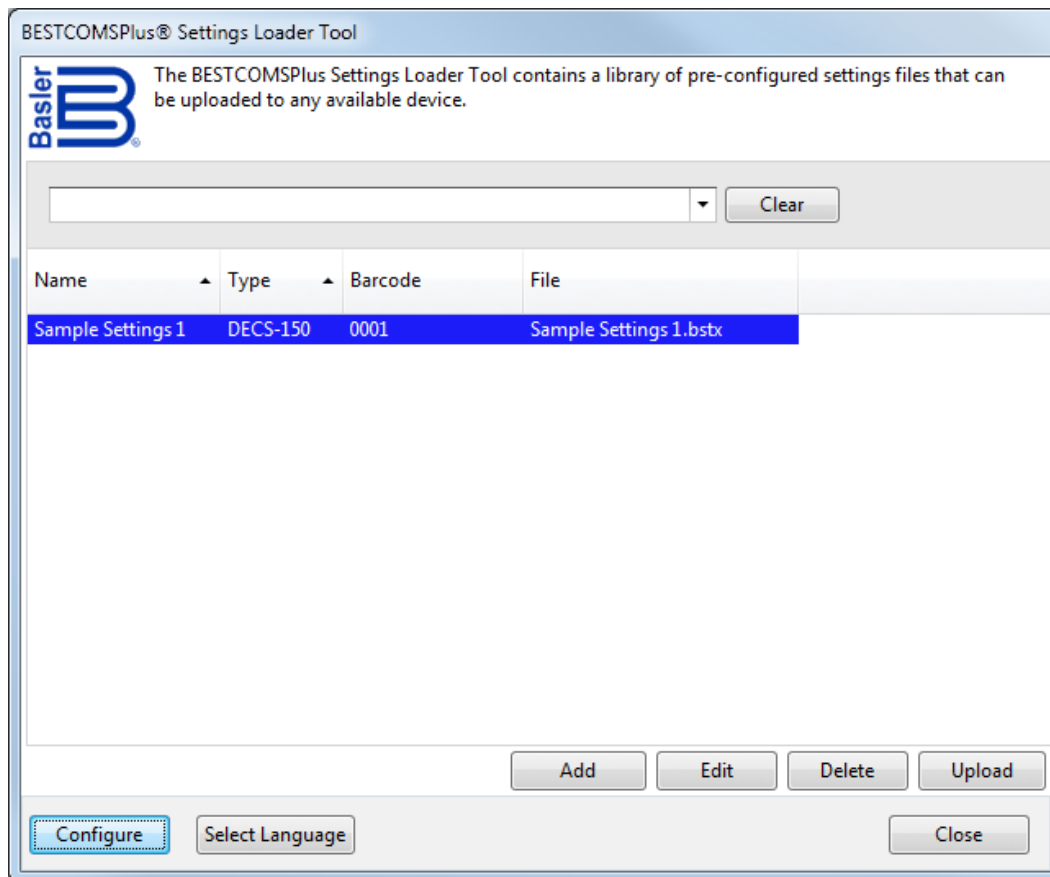


Figure 29-1. Loader Grid

Scanning Bar Codes

Place the cursor in the text field, found at the top of the Loader Grid screen, and scan a bar code. If successful, the digits which comprise the bar code appear in the text field. The BESTCOMSPPlus Settings Loader Tool automatically searches for this bar code among the entries in the Loader Grid and displays the matching entry. Click Clear to remove the digits from the text field.

Adding an Entry

Click Add to create an entry. The *BESTCOMSPPlus® Settings Loader Tool: Add Device* dialog box appears (Figure 29-2).

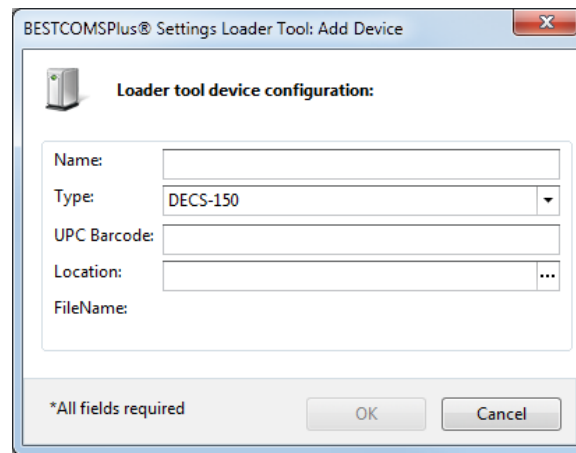


Figure 29-2. Add Device Screen

Enter the name of the entry in the *Name* field. This appears in the first column of the Loader Grid.

Select the product type from the *Type* drop-down menu. This appears in the second column of the Loader Grid.

Enter the bar code of the entry in the *UPC Barcode* field by placing the cursor in the UPC Barcode field and scanning the bar code.

To select the product settings file for the entry, click the browse (...) button in the *Location* field. Use standard Windows methods to navigate to the desired product settings file and click Open. Ensure that the selected product type in the *Type* field matches that of the product settings file specified in the *Location* field.

Click OK when finished.

Editing an Entry

To Edit an existing entry, select the entry in the Loader Grid and click Edit. The *BESTCOMSPPlus Settings Loader Tool: Edit Device* dialog box appears. The options are identical to those of the *Add Device* dialog. When the desired changes have been made, click OK.

Deleting an Entry

To delete an entry from the Loader Grid, select the entry and click the Delete button. A prompt appears providing the option to confirm or cancel the deletion.

Uploading an Entry

Select an entry and click Upload. A dialog appears which provides connection options for the appropriate type of device. Refer to the Basler product instruction manual for detailed connection information. Once a connection is established, the product settings associated with the entry are uploaded.

Configuration Settings

For configuration settings, click the *Configure* button in the bottom left of the Loader Grid. The product tabs on the left represent the compatible Basler products. Each product tab contains tabs for Settings Files and Connection Options. The options on these tabs are described below.

Setting Files Options

Use Saved Path: When enabled, the path specified in the Loader Grid entry is used when uploading the settings file.

Single Folder: When enabled, this specifies a single folder which contains all settings files for the product. The Windows filename specified in the Location field of the Loader Grid entry is searched for in the Single Folder location. For example, all settings files for a product are located in "C:\files". The

Location field in the Loader Grid entry for a device contains “C:\documents\settings\DECS-150 Settings.bstx”. The BESTCOMSPi^{us} Settings Loader Tool searches in “C:\files” for the file named “DECS-150 Settings.bstx”.

Append Bar-Code to Location: When enabled, the bar code is appended to the specified location when uploading the settings file. For example, an entry with the bar code “0002” is located in C:\files\0002 and an entry with the bar code “0003” is located in C:\files\0003.

Logon: If User Name and Password are specified, you will not be prompted for credentials when required.

Save After Upload: After uploading a settings file, the settings are downloaded from the connected device and saved to the specified location, when enabled.

Upload Security: When enabled, the security settings stored in the settings file are uploaded to the device. Credentials will be requested if not already specified.

Figure 29-3 illustrates the Setting Files tab.

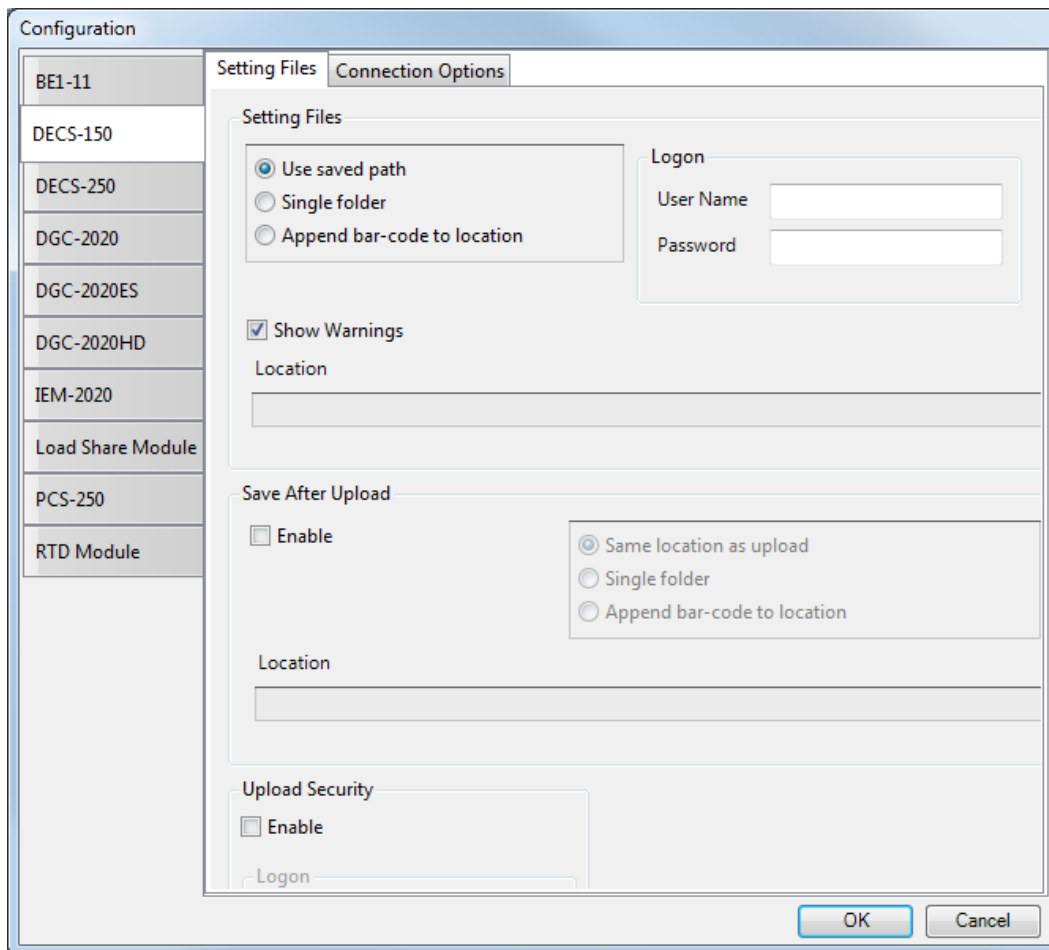


Figure 29-3. Configuration, Settings Files Tab

Connection Options

Connection options consist of the three selections described below. Refer to the Basler product instruction manual for detailed connection information.

Always Prompt for Connection: When enabled, a dialog appears which provides connection options for the appropriate type of device each time a connection attempt is made.

Ethernet Connection: When enabled, the BESTCOMSPi^{us} Settings Loader Tool automatically attempts to connect to the specified IP address before uploading settings.

USB Connection: When enabled, the BESTCOMSPi^{us}® Settings Loader Tool automatically attempts to connect to the device via USB port before uploading settings.

Figure 29-4 illustrates the Connection Options tab.

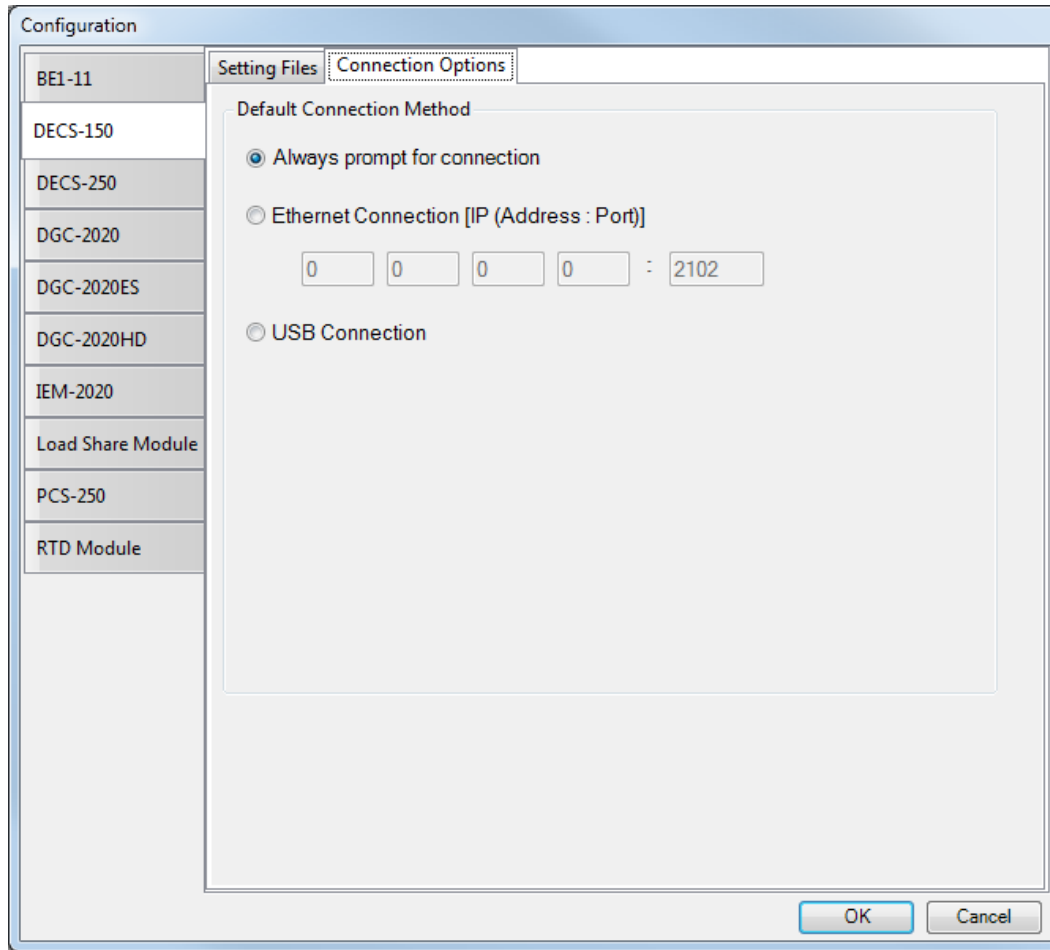


Figure 29-4. Configuration, Connection Options Tab

General Operation

The steps listed below are provided as a general guideline for how to operate the BESTCOMSPi^{us} Settings Loader Tool when the initial setup is complete and the settings files are associated with bar codes.

1. Power on the device which will receive the new settings. Ensure proper communication connections have been made between the device and the PC running BESTCOMSPi^{us} Settings Loader Tool.
2. Run BESTCOMSPi^{us} Settings Loader Tool.
3. Place cursor in search bar.
4. Scan bar code.
5. Settings file is automatically highlighted and isolated in the grid.
6. Click Upload.
7. BESTCOMSPi^{us} Settings Loader Tool automatically connects to device and uploads settings. Device connection is automatic unless “Always prompt for connection” is enabled.





Highland, Illinois USA
Tel: +1 618.654.2341
Fax: +1 618.654.2351
email: info@basler.com

Suzhou, P.R. China
Tel: +86 512.8227.2888
Fax: +86 512.8227.2887
email: chinainfo@basler.com