

# **INSTRUCTION MANUAL**

**FOR**

**DIGITAL EXCITATION CONTROL SYSTEM**

**Model: DECS 125-15**

**Part Number: 9 2653 00 112**

**For DECS Software Version 1.6.0 and Earlier**



**Publication Number: 9 2653 00 991**  
**Revision: H 04/98**

## INTRODUCTION

---

This manual provides information concerning the operation and installation of a DECS 32-15, 63-15, & 125-15 Digital Excitation Control System. To accomplish this, the following is provided.

- Specifications
- Functional Description
- Installation Information
- Operation
- Maintenance

### **WARNING**

**TO AVOID PERSONAL INJURY OR EQUIPMENT DAMAGE, ONLY QUALIFIED PERSONNEL SHOULD PERFORM THE PROCEDURES PRESENTED IN THIS MANUAL.**

### **CAUTION**

**Meggers and high potential test equipment should be used with extreme care. Incorrect use of such equipment could damage components contained in the device.**

First Printing: August 1994

Printed in USA

© 1997, 1998, Basler Electric Co., Highland, IL 62249

April 1998

**CONFIDENTIAL INFORMATION**

OF BASLER ELECTRIC COMPANY, HIGHLAND, IL. IT IS LOANED FOR CONFIDENTIAL USE, SUBJECT TO RETURN ON REQUEST, AND WITH THE MUTUAL UNDERSTANDING THAT IT WILL NOT BE USED IN ANY MANNER DETRIMENTAL TO THE INTEREST OF BASLER ELECTRIC COMPANY.

It is not the intention of this manual to cover all details and variations in equipment, nor does this manual provide data for every possible contingency regarding installation or operation. The availability and design of all features and options are subject to modification without notice. Should further information be required, contact Basler Electric Company, Highland, Illinois.

**BASLER ELECTRIC  
ROUTE 143, BOX 269  
HIGHLAND, IL 62249 USA**

**<http://www.basler.com>, [info@basler.com](mailto:info@basler.com)**

**PHONE 618-654-2341**

**FAX 618-654-2351**

# CONTENTS

|           |  |      |
|-----------|--|------|
| SECTION 1 | GENERAL INFORMATION.....                               | 1-1  |
|           | General .....  | 1-1  |
|           | Specifications .....                                   | 1-2  |
| SECTION 2 | FUNCTIONAL DESCRIPTION.....                            | 2-1  |
|           | Power Supply .....                                     | 2-1  |
|           | Power Amplifier Stage .....                            | 2-1  |
|           | Display .....  | 2-1  |
|           | Voltage Matching Circuitry.....                        | 2-1  |
|           | Phase B Current Sensing Circuit .....                  | 2-2  |
|           | RMS Sensing Circuitry .....                            | 2-2  |
|           | Pushbutton/Contact Input Circuitry .....               | 2-2  |
|           | Auxiliary Input Circuitry.....                         | 2-2  |
|           | Serial Communications Port .....                       | 2-2  |
|           | Microprocessor.....                                    | 2-2  |
|           | Alarm .....  | 2-2  |
|           | Manual Excitation Control Circuitry .....              | 2-3  |
| SECTION 3 | INSTALLATION.....                                      | 3-1  |
|           | Mounting .....   | 3-1  |
|           | Interconnection.....                                   | 3-5  |
|           | Remote Adjust.....                                     | 3-5  |
|           | Sensing Voltage .....                                  | 3-5  |
|           | Power Output.....                                      | 3-5  |
|           | Power Input.....                                       | 3-6  |
|           | Paralleling Input.....                                 | 3-6  |
|           | Field Flashing.....                                    | 3-7  |
|           | Voltage Matching Input.....                            | 3-7  |
| SECTION 4 | OPERATION .....  | 4-1  |
|           | General .....  | 4-1  |
|           | Preliminary Set-Up .....                               | 4-3  |
|           | Adjustments .....                                      | 4-3  |
|           | Course Voltage Adjustment .....                        | 4-3  |
|           | Fine Voltage Adjustment .....                          | 4-4  |
|           | Fine Voltage Adjustment Band .....                     | 4-4  |
|           | Manual Mode Switch .....                               | 4-4  |
|           | Manual Mode Setpoint.....                              | 4-4  |
|           | Underfrequency.....                                    | 4-4  |
|           | Volts per Hertz Slope .....                            | 4-4  |
|           | Stability Range Select .....                           | 4-5  |
|           | Stability Level Adjustment.....                        | 4-5  |
|           | VAR/Power Factor Adjustments .....                     | 4-8  |
|           | Droop Adjustment.....                                  | 4-8  |
|           | Underexcitation Limiting/Overexcitation Limiting ..... | 4-10 |
|           | Overexcitation Select .....                            | 4-10 |
|           | Softstart .....  | 4-10 |
|           | DECS Sensing Configuration.....                        | 4-10 |
|           | Current Transformer Primary Rating.....                | 4-11 |
|           | Sensing Potential Transformer Ratio .....              | 4-11 |
|           | Voltage Matching.....                                  | 4-11 |
|           | Voltage Matching Band .....                            | 4-11 |

# CONTENTS - Continued

|           |   |      |
|-----------|---|------|
| SECTION 4 | OPERATION - Continued   |      |
|           | Voltage Matching Speed.....   | 4-12 |
|           | Voltage Matching Step.....  | 4-12 |
|           | Front Panel Operation .....   | 4-12 |
|           | Status and Diagnostic LED's.....  | 4-12 |
|           | Alpha Numeric Display.....  | 4-13 |
|           | DECS Communication Interface Module (DCIM).....   | 4-14 |
|           | DECS Alarm Enable/Disable.....  | 4-14 |
|           | DECS Shutdown Enable/Disable .....  | 4-14 |
| SECTION 5 | MAINTENANCE.....  | 5-1  |
|           | Preventive Maintenance .....  | 5-1  |
|           | Corrective Maintenance .....  | 5-1  |
|           | Warranty and Repair Service .....   | 5-1  |
|           | Troubleshooting.....  | 5-1  |
|           | No Voltage Build-up.....  | 5-1  |
|           | Low Output Voltage .....  | 5-2  |
|           | High Output Voltage .....   | 5-3  |
|           | Generator Does Not Respond as Adjustments Are Made.....                                 | 5-3  |
|           | Poor Voltage Regulation .....   | 5-3  |
|           | Generator Output Unstable.....  | 5-3  |
|           | Front Panel UF LED is Illuminated .....   | 5-4  |
|           | Front Panel OVEREXC LED is illuminated.....   | 5-4  |
|           | No Droop or Negative Droop.....   | 5-4  |
|           | No Voltage Matching .....   | 5-5  |
|           | Fine Voltage Adjust Band Not Centered Around the Coarse<br>Voltage Adjust Setting ..... | 5-5  |
|           | No Communication With DCIM Unit .....   | 5-6  |
| SECTION 6 | REPLACEMENT PARTS .....   | 6-1  |
|           | General .....   | 6-1  |
| SECTION 7 | MANUAL CHANGE INFORMATION .....   | 7-1  |
|           | Changes.....  | 7-1  |

# SECTION 1 • GENERAL INFORMATION

## GENERAL

The Basler Digital Excitation Control System (DECS) is an electronic, solid-state, micro-processor based control device. DECS regulates the voltage output of a brush-type or brushless, ac generator by controlling the current into the generator exciter field. Input power to the DECS can be from a multi-pole, high-frequency, permanent magnet generator (PMG), or from the generator output when used as a conventional shunt-excited excitation system through the DECS Power Module. This module is included with every DECS.

Refer to Figure 1-1 for the DECS style chart. In the example shown in the chart, a DECS 32-15 A2C1 VXX is specified. This is a DECS which provides 32 Vdc at a maximum of 15 Adc to the field. An available option which was not selected is VAR/PF control. An option that was selected is Overexcitation Limiting/Underexcitation Limiting. An option for 1 or 5A secondary current transformers, was selected for 1 Amp. The software version number, which is intended for general reference only, will be added at the factory to describe the software version installed.

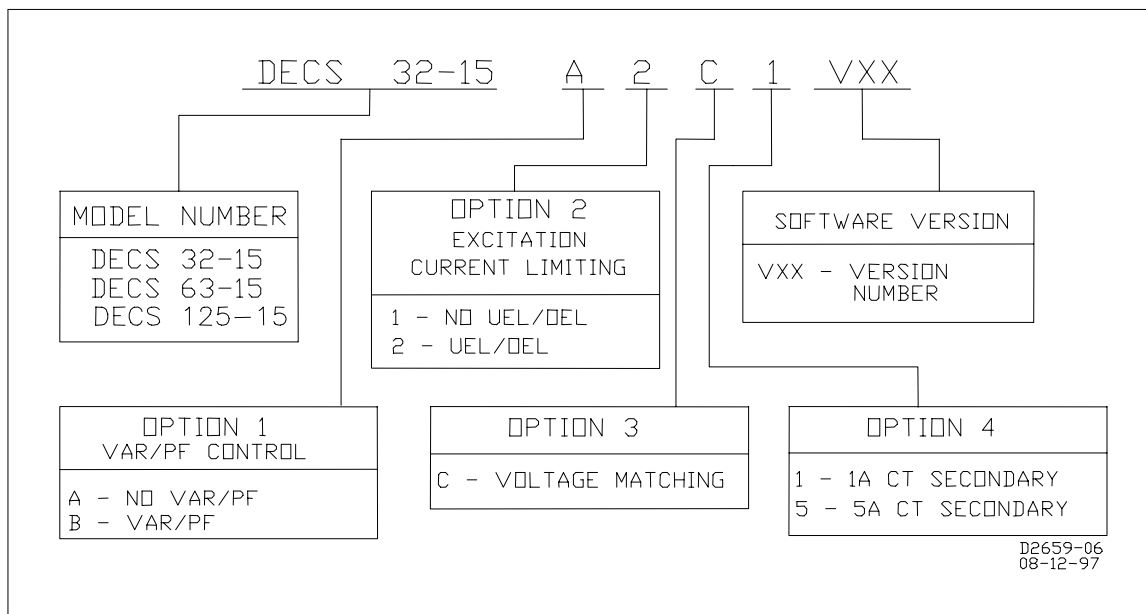

Figure 1-1. DECS Style Chart

## SPECIFICATIONS

Refer to Tables 1-1 and 1-2 for the DECS electrical specifications, Table 1-3 for generator field requirements, and to Table 1-4 for the DECS physical specifications.

*Table 1-1. DECS Electrical Specifications*

|   |   |
|---|---|
| <b>Regulation Accuracy:</b>             | Regulates within $\pm 0.25\%$ of nominal, no-load to full-load.   |
| <b>Power Input:</b>                     | See Table 1-2.  |
| <b>Input Sensing:</b>                   | 120, 208, 240, 416, 480, or 600 Vac $\pm 10\%$ , 60 Hz nominal, 100, 220, or 400 Vac $\pm 10\%$ , 50 nominal, Selectable single-phase or three-phase RMS.   |
| <b>Sensing Burden:</b>                  | <1 VA per phase.  |
| <b>External Voltage Adjust Range:</b>   | Customer-adjustable from $\pm 6V$ to $\pm 60V$ in 0.5V steps.   |
| <b>Underfrequency (V/Hz) Limiting:</b>  | Customer adjustable from continuous to 3 times V/Hz. Transition frequency ("corner" frequency) is adjustable from 40 Hz to 65 Hz. (Refer to Figure 1-2 for V/Hz curves.)                                  |
| <b>Parallel Compensation:</b>           | Can use either reactive droop or reactive differential (cross-current) compensation. Adjustable 20% voltage droop with optional 1 A or less or 5 A or less input. For parallel compensation, burden <1VA. |
| <b>Accessory Input:</b>                 | A $\pm 3$ Vdc input results a $\pm 30\%$ change in regulated voltage. Input impedance is 1k $\Omega$ .  |
| <b>Alarm Indication:</b>                | Triac output rated at 30 Vdc (24V Nominal) at 150 mA latched with external Dc source.   |
| <b>Overvoltage Protection:</b>          | Factory preset at 35% above nominal with a 0.75 sec. time delay.  |
| <b>Soft-Start Ability:</b>              | Included with customer adjustable rate of build-up.   |
| <b>Solid State (Internal) Build-up:</b> | Minimum of 8 Vac power input required.  |
| <b>Over Excitation Limiting:</b>        | See Figure 1-3.   |
| <b>Under Excitation Limiting:</b>       | Adjustable from 0-100% maximum reactive current.  |
| <b>Manual Excitation Control:</b>       | Regulates field current from 0.0 Amps to 25.0 Amps.   |
| <b>Voltage Matching:</b>                | Matches utility bus RMS voltage with generator output RMS voltage to within 1%.   |

Table 1-2. DECS Electrical Specifications - Power Input Requirements (50-400 Hz)

| DECS Model No.   | Nominal Input        | Power Input Into Power Module (50 - 400 Hz)   | Burden  |
|------------------|----------------------|---|---------|
| DECS 32-15-XXXX  | 60 V <sub>RMS</sub>  | 56 - 70 V <sub>RMS</sub> ±10%, 1 or 3 Phase   | 780 VA  |
| DECS 63-15-XXXX  | 120 V <sub>RMS</sub> | 100 - 139 V <sub>RMS</sub> ±10%, 1 or 3 Phase | 1570 VA |
| DECS 125-15-XXXX | 240 V <sub>RMS</sub> | 190 - 277 V <sub>RMS</sub> ±10%, 1 or 3 Phase | 3070 VA |

Table 1-3. Generator Field Requirements

|  | DECS 32-15 | DECS 63-15 | DECS 125-15 |
|--|------------|------------|-------------|
| Minimum Field Resistance at 25°C                               | 2.13 Ω     | 4.2 Ω      | 8.3 Ω       |
| Rated Continuous Field Voltage                                 | 32 Vdc     | 63 Vdc     | 125 Vdc     |
| Rated 10-Second Forcing Voltage For Rated Power Input Voltage* | 50 Vdc     | 100 Vdc    | 200 Vdc     |
| Rated Maximum Field Current                                    | 15 Adc     | 15 Adc     | 15 Adc      |
| Rated 10-Second Forcing Current                                | 30 Adc     | 30 Adc     | 30 Adc      |
| Rated 120 Second Forcing Current                               | 20 Adc     | 20 Adc     | 20 Adc      |

The above parameters are with nominal RMS voltage levels listed in Table 1-2 above.

\* Forcing voltages may be up to 50% greater than listed if:

- 1) 3 Phase input power is used, OR
- 2) Field current is significantly lower than that listed.  
Please consult factory for further details.

Table 1-4. DECS Physical Specifications

|   |   |
|---|---|
| <b>UL Recognized/<br/>CSA Certified</b> | UL Recognized per Standard 508, UL File No. E 97035. CSA Certified per Standard CAN/CSA-C22.2 No. 14-M91, CSA File No. LR 23131-139. Note: Output contacts are not UL recognized/CSA Certified for voltages greater than 250 volts. |
| <b>Operating Temperature:</b>           | -40°C to +60°C.   |
| <b>Storage Temperature:</b>             | -40°C to +85°C.   |
| <b>Shock:</b>                           | 15 G's in each of three mutually perpendicular planes.  |
| <b>Vibration:</b>                       | 1 G at 5 to 26 Hz.<br>0.036" double amplitude at 27 to 52 Hz.<br>5 G's at 53 to 500 Hz.   |
| <b>Weight:</b>                          | 9 lbs. (4.05 kg) net, 12 lbs. (5.40 kg) shipping.   |

Table 1-5. DECS Power Transformer Selection Chart

| Primary Voltage | DECS 32-15-XXX | DECS 63-15-XXX |              | DECS 125-15-XXX |              |
|-----------------|----------------|----------------|--------------|-----------------|--------------|
|                 | 3 Phase        | 3 Phase        | 1 Phase      | 3 Phase         | 1 Phase      |
| 240             |                |                | BE 22209-001 |                 | BE 12819-001 |
| 480             | BE 24588-001   | BE 26103-001   | BE 22209-001 | BE 26660-001    | BE 21819-001 |
| 600             |                |                | BE 11050-001 | BE 26819-001    | BE 22209-001 |
| 2400            |                | BE 20221-001   | BE 13487-001 | BE 21027-001    | BE 12818-001 |
| 4160            |                | BE 21027-001   | BE 13487-001 | BE 21027-001    | BE 12818-001 |
| 7200            |                |                | BE 22136-001 | BE 25921-001    | BE 22136-001 |
| 13800           |                |                | BE 21327-001 | BE 26728-001    | BE 21327-001 |

Note to the customer: If your transformer needs cannot be satisfied from this chart, please consult the factory.

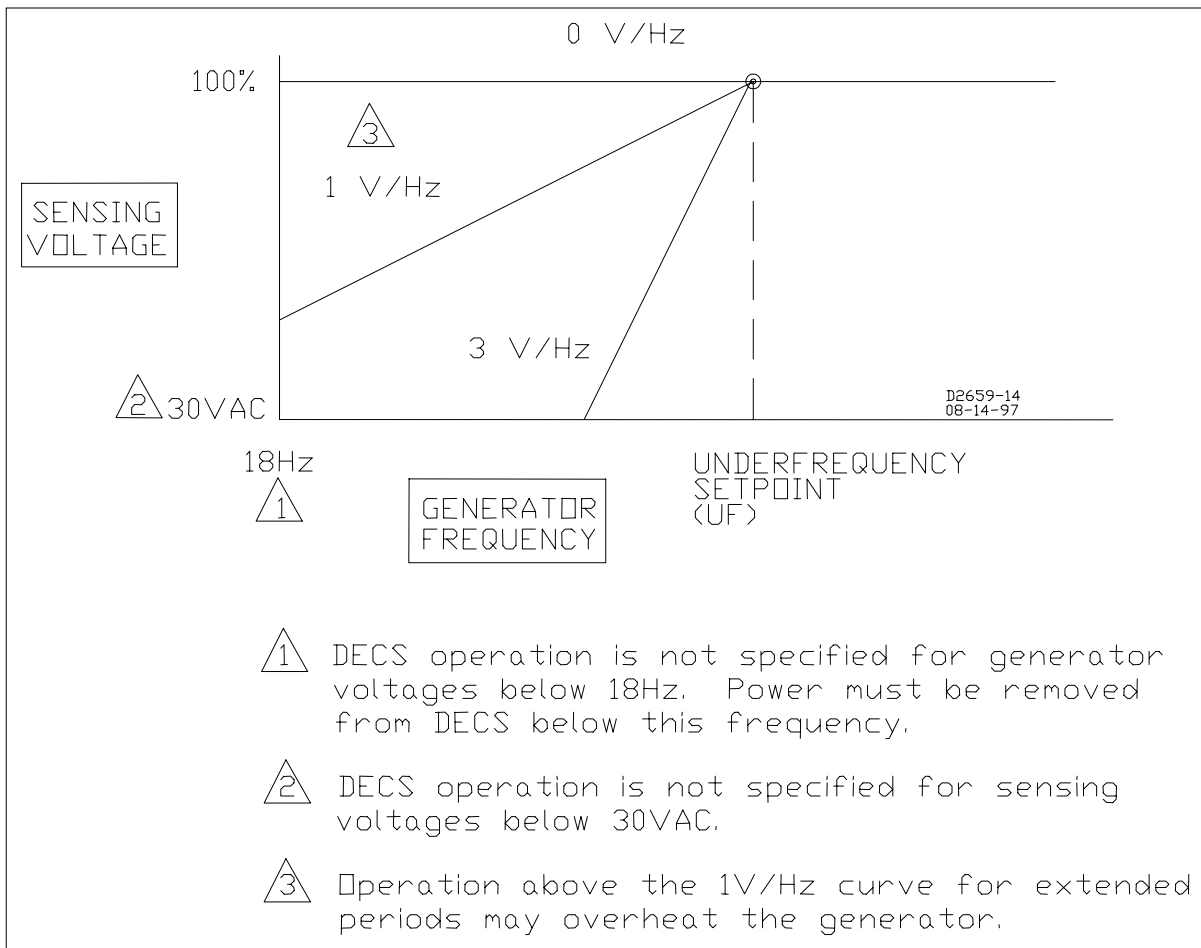

Figure 1-2. Typical Volts per Hertz Curves

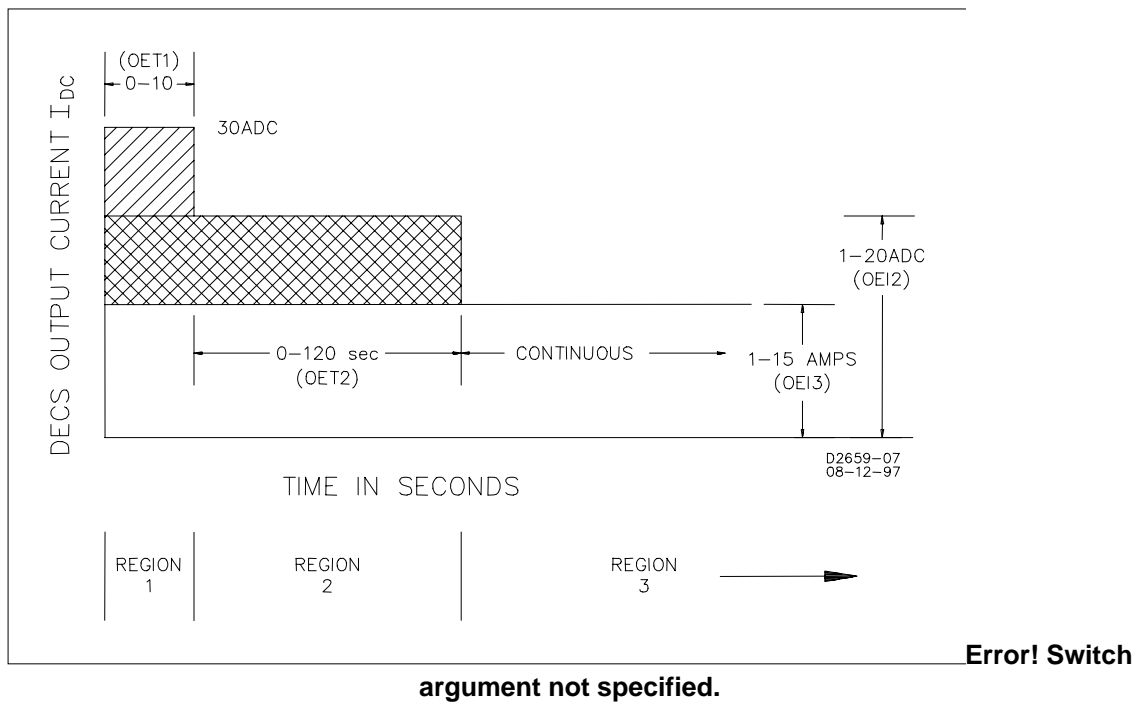

Figure 1-3. Overexcitation Limiter

## SECTION 2 • FUNCTIONAL DESCRIPTION (Refer to Figure 2-1)

---

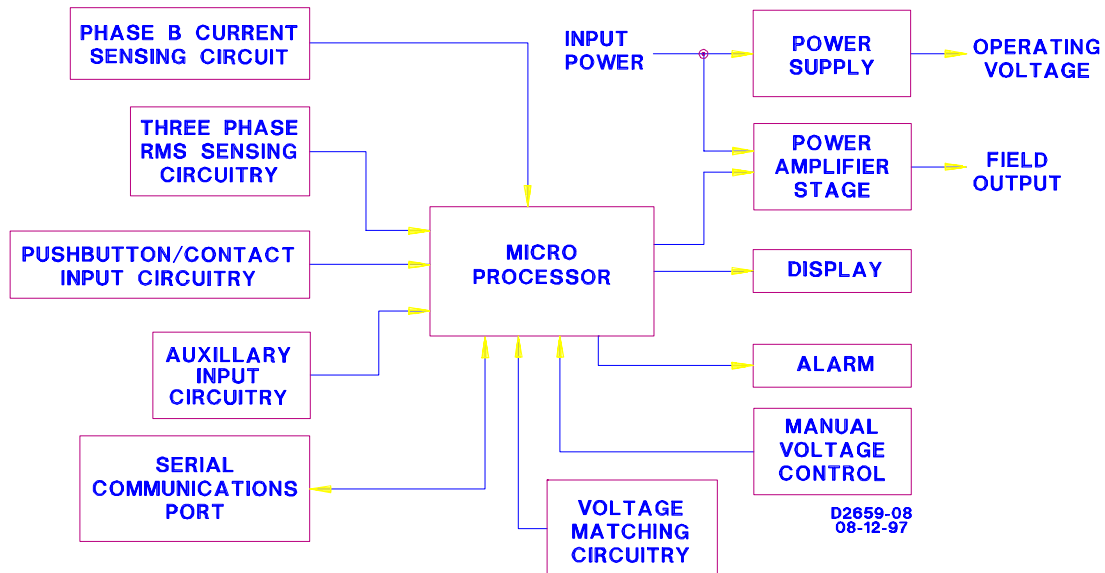

Figure 2-1. DECS-15 Block Diagram

---

### POWER SUPPLY

The Power Supply converts the input voltage, rectifies and filters it, and supplies all the operating voltages required by the internal circuitry of the DECS. A minimum of 8 Vac into the DECS Power Module is required to allow automatic generator line voltage buildup when using DECS.

---

### POWER AMPLIFIER STAGE

The Power Amplifier receives input power and will output the field voltage and current depending upon the timing of the firing pulses from the Micro-Processor. The Power Amplifier uses a single IGBT for supplying the field voltage and current required by the exciter.

---

### DISPLAY

The front panel Display consists of nine LEDs and an alphanumeric display. The LEDs continually monitor the unit's condition. The four-character alphanumeric display is for system set-up/adjustment and the monitoring of select conditions. The LED and the alphanumeric display are controlled by the Micro-Processor.

---

### VOLTAGE MATCHING CIRCUITRY

This circuit will control the generator output and match it to the bus prior to synchronizing. This circuit is enabled via the front panel of DECS or the optional DECS Communication Interface Module (DCIM).

---

## PHASE B CURRENT SENSING CIRCUIT

This circuit monitors the generator current output on phase B. This signal is rectified and converted within the DECS to a digital signal for use by the Micro-Processor. It is used for measuring PF and VARs. It is also used when paralleling the generators.

---

## RMS SENSING CIRCUITRY

This circuit monitors the generator voltage output on any or all three phases. This signal is rectified and converted within the DECS to a digital signal for use by the Micro-Processor. It is selectable through the adjustment menu on the front panel of the DECS.

---

## PUSHBUTTON/CONTACT INPUT CIRCUITRY

This circuit provides a means for the front panel pushbuttons and the external switch contacts to interact with the Micro-Processor and control the DECS operation.

---

## AUXILIARY INPUT CIRCUITRY

This circuit allows an external device to control the DECS output and, thus the generator output voltage. This is accomplished by receiving a  $\pm 3$  Vdc voltage. The circuit induces a 1K  $\Omega$  burden on the  $\pm 3$  Vdc customer supplied source. A  $\pm 30\%$  change in generator output voltage is associated with a  $\pm 3$  Vdc signal received into terminals A & B.

Table 2-1.

| DECS Style      | Vdc Applied At DECS Terminals |       | Change In Gen. Output Voltage | DECS Display "ACC" Polarity |
|-----------------|-------------------------------|-------|-------------------------------|-----------------------------|
| DECS XXX-15-XXC | + @ A                         | - @ B | Increase                      | +                           |

---

## SERIAL COMMUNICATIONS PORT

The Serial Communications Link is a connector which allows communication between the DECS and a PC through the use of the optional DCIM (DECS Communication Interface Module) and the Basler Software Diskette provided with the DCIM. The port is used for troubleshooting and re-programming of the DECS. A more detailed description is provided later in this manual.

---

## MICROPROCESSOR

The Micro-Processor controls all functions of the DECS by the use of its built-in programming. It has an EEPROM which provides a non-volatile memory for storing settings after power is removed from the unit. This enables customer programming of the setpoints before and after unit installation.

---

## ALARM

This circuit is a triac output which is controlled by the microprocessor and the internal overexcitation hardware. This circuit is a protective feature which is rated at 30 Vdc at 150 mA. The triac, if enabled, will latch if monitored trouble conditions occur, and then stay latched even after power is removed from the DECS unit. Upon repowering the DECS, the triac will remain latched until the external DC source is de-energized.

---

## **MANUAL EXCITATION CONTROL CIRCUITRY**

The manual excitation control allows an operator to manually set the amount of the dc excitation current output of DECS. Once set, DECS will regulate that current. This circuit is also used for the case of the loss of sensing voltage. DECS will regulate the dc excitation current setpoint if the sensing voltage is lower than 25% of the generator terminal voltage for more than a customer adjustable activation delay time. This circuit is not intended as a back-up system to the Automatic mode of operation. It will be useful in the commissioning of the generator system.

# SECTION 3 • INSTALLATION

## MOUNTING

The DECS is normally located in the generator conduit box, but is also designed to operate in remote switchgear cubicles with convection cooling. When remotely mounted, the DECS may either be mounted through the panel or behind the panel with the optional behind the panel mounting kit. Figures 3-1 through 3-3 provide the DECS outline dimensions and Figure 3-4 provides the DECS Behind the Panel Mounting Kit dimensions.

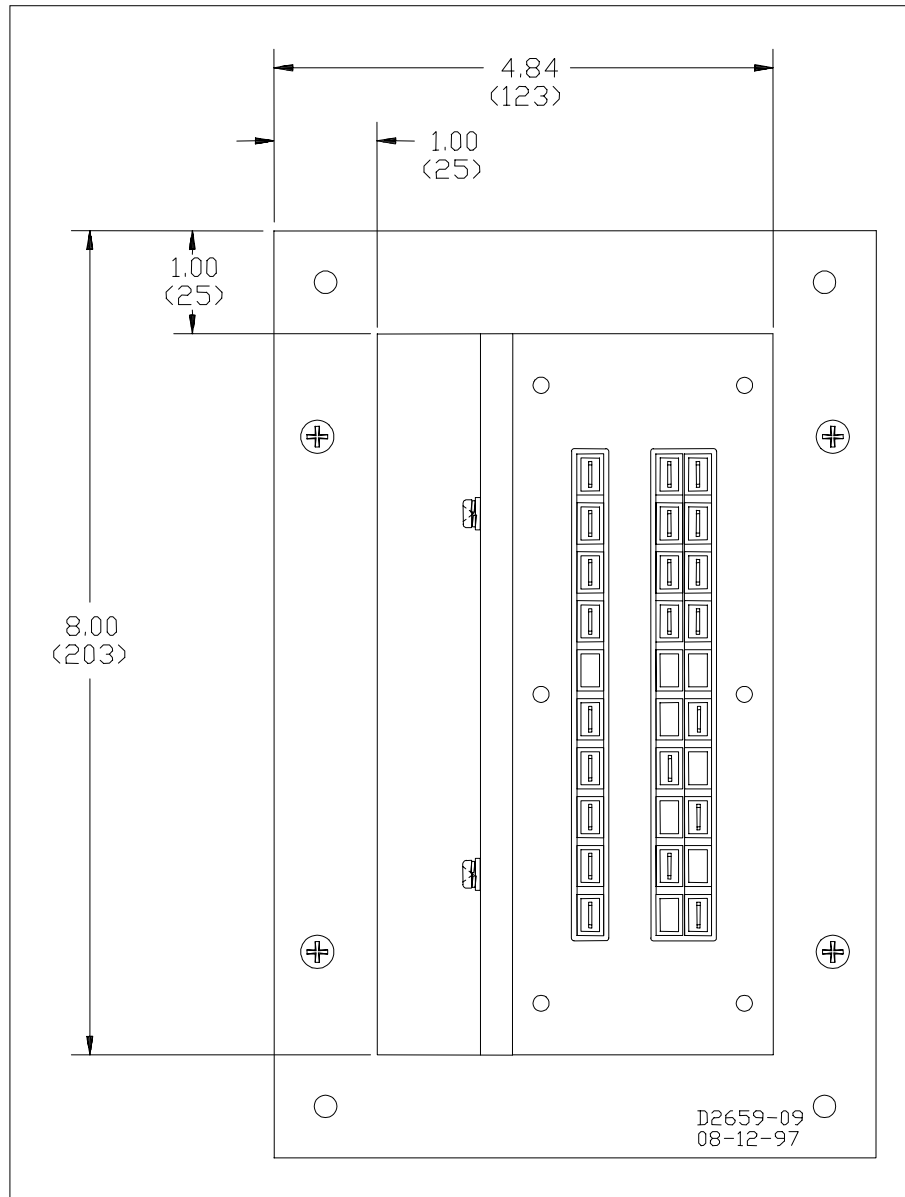

Figure 3-1. DECS Outline Drawing, Front View

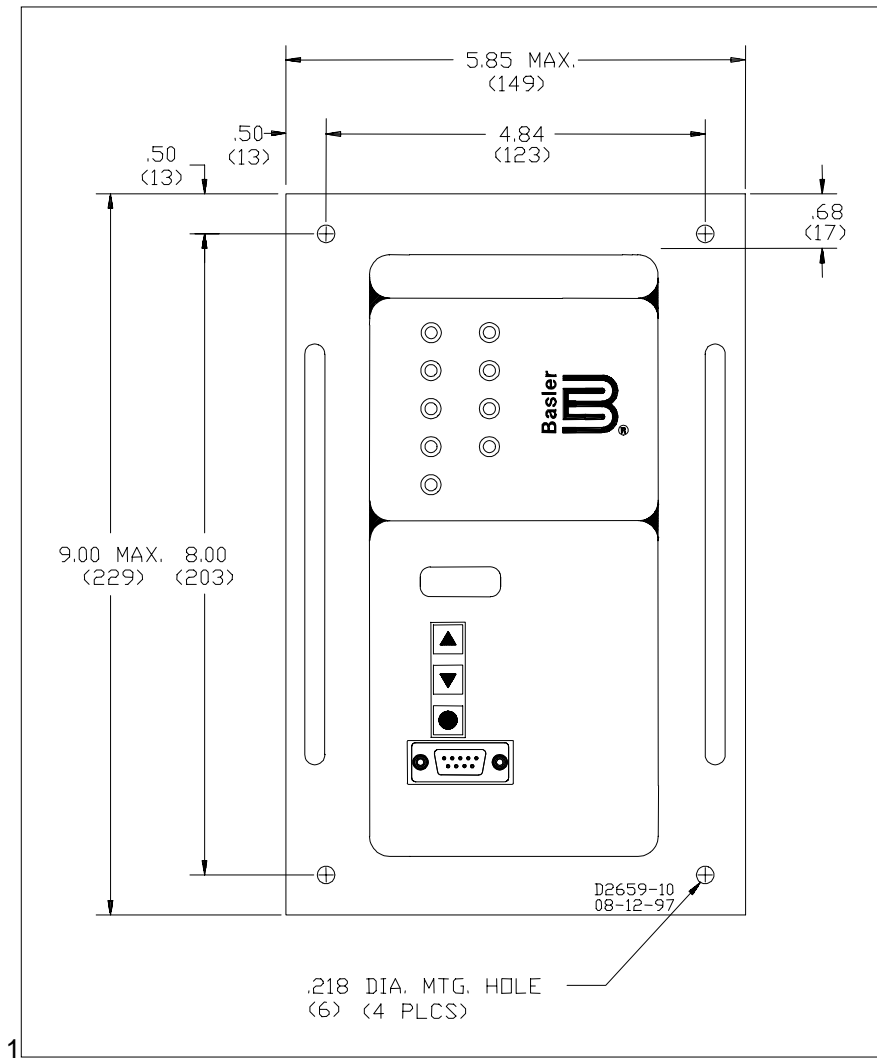

Figure 3-2. DECS Outline Drawing, Rear View

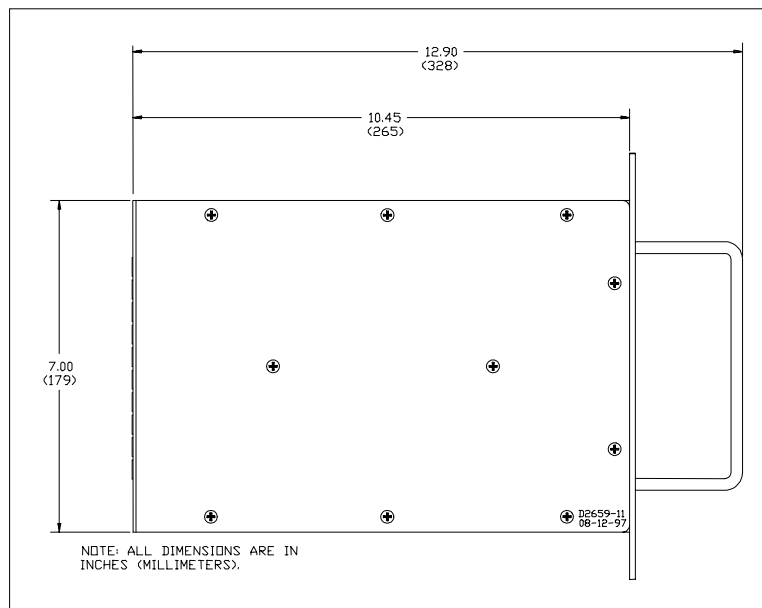

Figure 3-3. DECS Outline Drawing, Side View

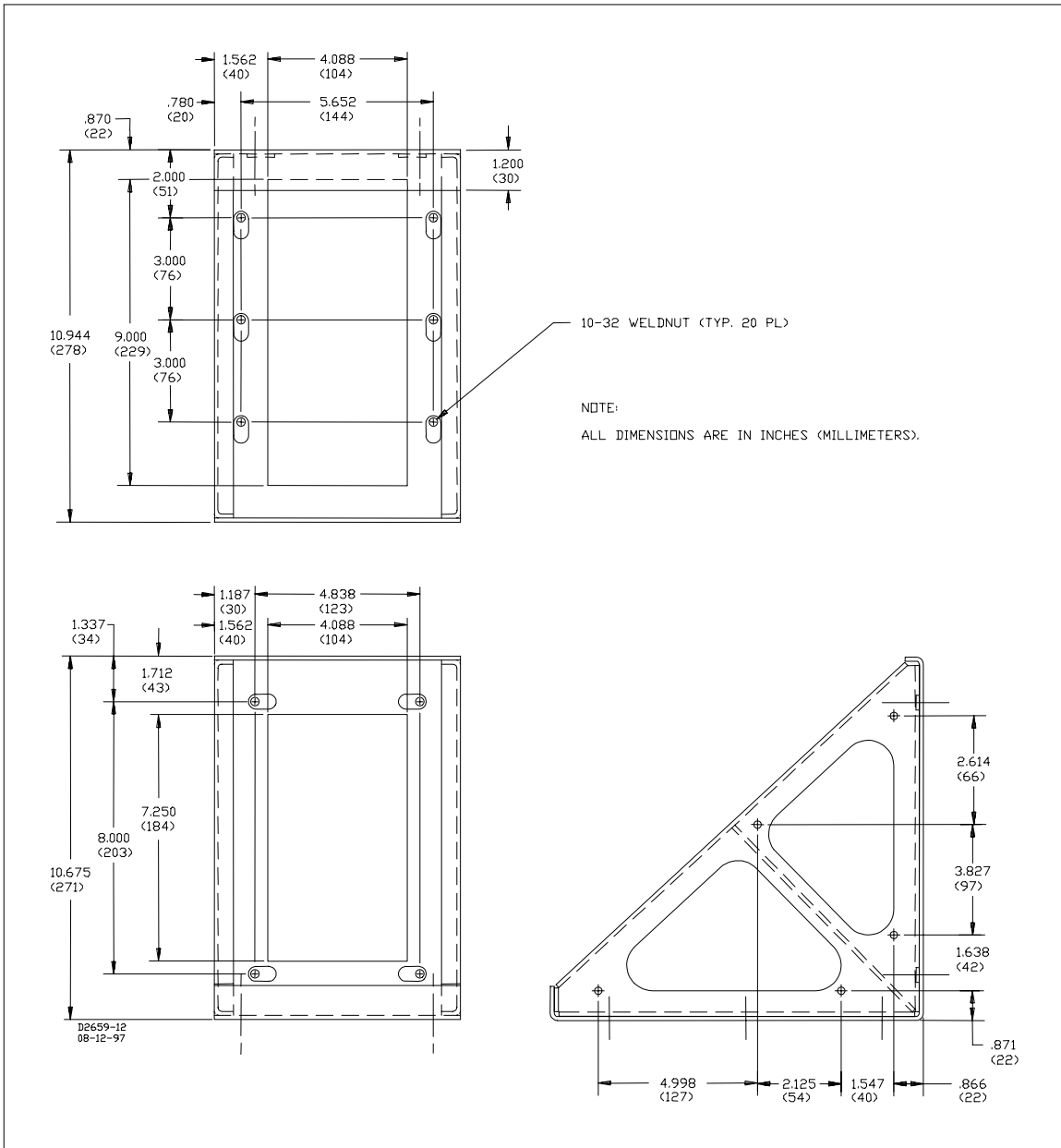

Figure 3-4. Behind the Panel Mounting Kit Outline Drawing  
P/N: 9 2653 04 100

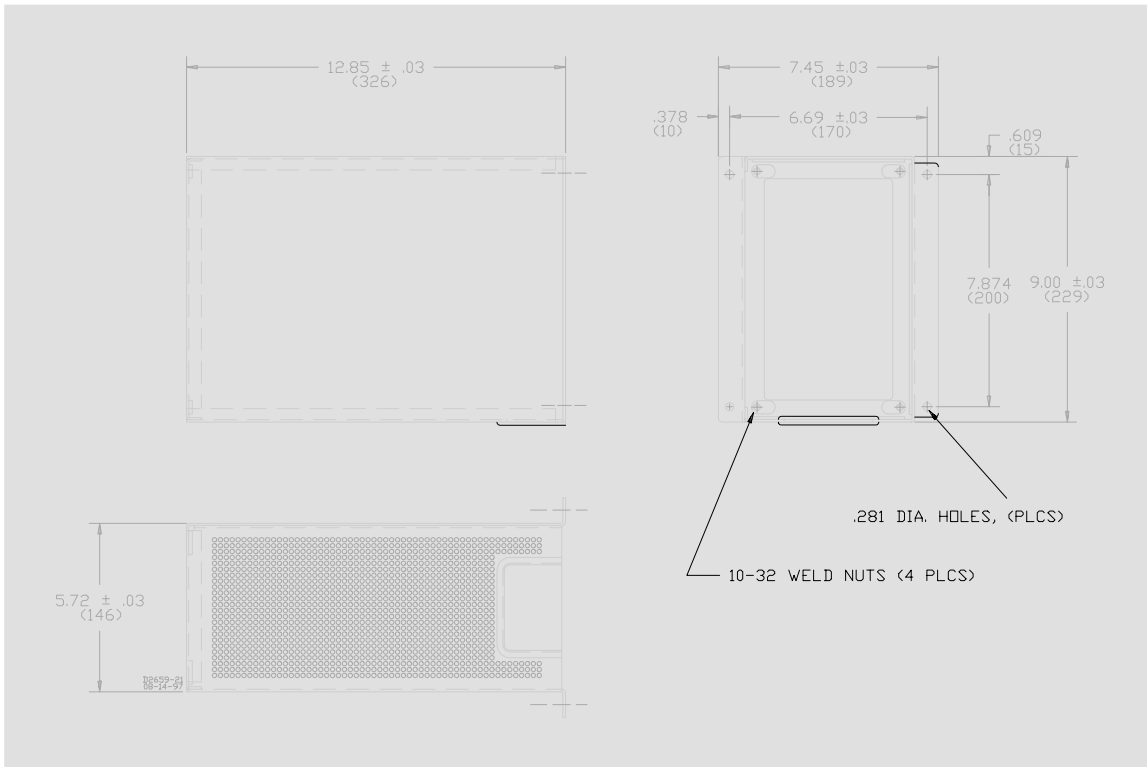

Figure 3-5. Rear Panel Mounting Kit Outline Drawing  
P/N: 9 2653 00 026

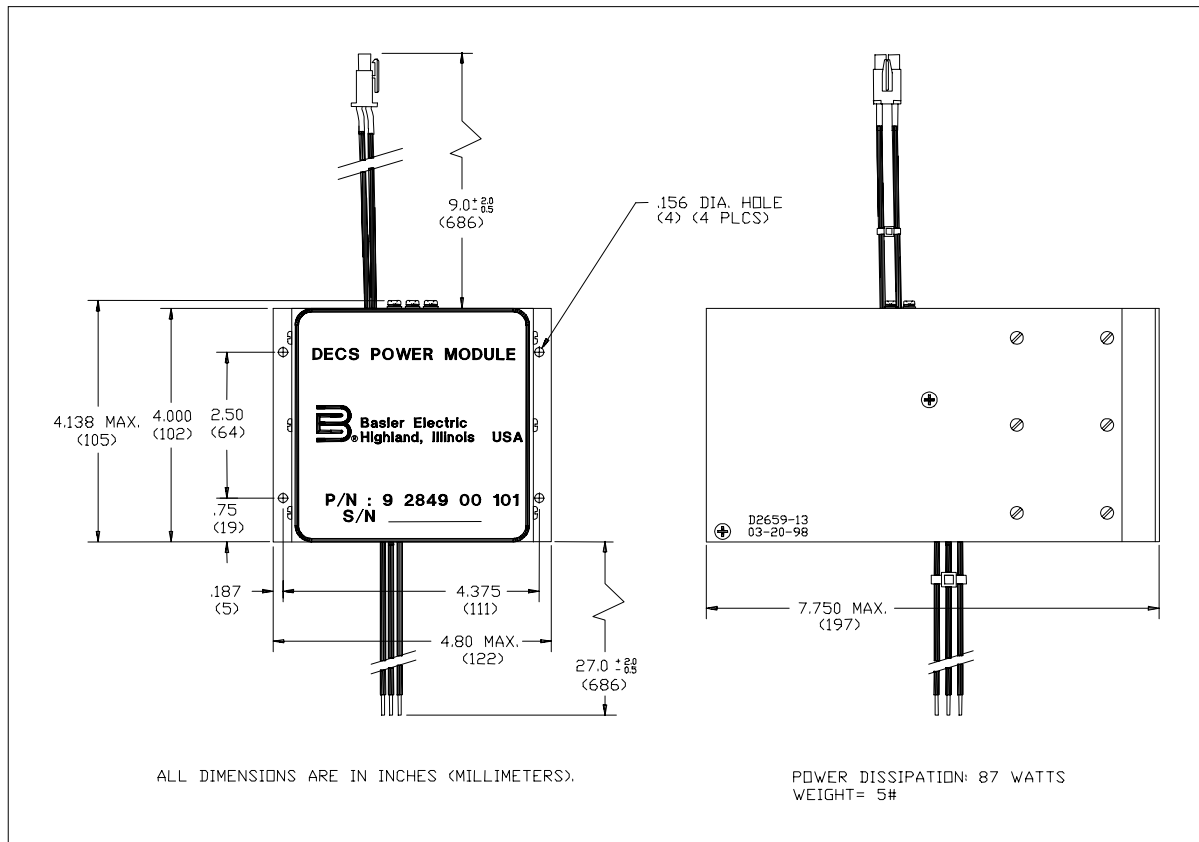

Figure 3-6. DECS Power Module Dimensions

---

## INTERCONNECTION

Connect the DECS as shown in Figures 3-7 through 3-10 and in accordance with the following paragraphs.

### CAUTION

**The case of the DECS must be properly connected to a suitable power system ground to ensure proper operation and to prevent the possibility of electrical shock.**

### CAUTION

**Do not megger or hipot the generator with the DECS connected. Do not megger or hipot the DECS. To do so will damage the internal electronics of the DECS.**

### NOTE

When shunt powered on generators with output voltages greater than the requirements of Table 1-2, an external potential transformer must be used to provide the proper input power to the DECS Power Module. Refer to Table 1-5 for power PT selection.

- (1) Whenever a potential transformer is used for sensing, an open circuit on the primary side of the transformer will cause maximum forcing from the regulator.
- (2) Verify that all connections are tight and secured from possible vibration.

### Remote Adjust

If a Remote Voltage Adjust is required, a single-pole, double-throw, spring-return, center-off, switch rated for 240 Vac, 1 A is best suited. To connect this switch, the center pole, or common terminal, must be connected to DECS terminal 7. The other two (2) poles or terminals are connected to DECS terminals 6U and 6D. Shorting terminals 6U to 7 causes the DECS to raise the setpoint of the mode of operation it is in; i.e., voltage, manual VARs or P.F. Similarly, shorting 6D to 7 causes the setpoint to be lowered. Care must be taken because "input power" voltage is present across terminals 6U, 6D, and 7. This connection can be made using any wire gauge from 12 to 22 (.3-2.5 m<sup>2</sup>). The Remote Voltage Adjust switch can be mounted up to 150 feet from the DECS when using twisted, shielded cable.

### Sensing Voltage

The DECS comes equipped for three-phase RMS voltage sensing as standard. It can optionally be used with single-phase sensing by connecting the Generator Output Phase A to the DECS Sensing terminal E1 and connecting the Generator Output Phase C to DECS Sensing terminals E2 and E3. The DECS sensing programming must agree with the type of interconnection. From the front panel, the proper phase rotation must be selected for three-phase sensing, A-B-C or A-C-B or the single-phase sensing setting (A-C) must be selected.

### Power Output

The DECS Power Output terminals are labeled F+ and F-. These terminals are connected to the Exciter Field Leads. Be sure to observe polarity (i.e.: DECS F+ must be connected to Generator F+ and DECS F- must be connected to Generator F-).

## CAUTION

The DECS Power Output terminals (F+ and F-) should never be disconnected during operation. This can result in permanent damage to the DECS unit. If a power switch is desired, it should be connected to the DECS Power Input terminals (3 & 4).

### Power Input

(Reference Table 1-2.) The DECS Power Input terminals are labeled 3 and 4. The DECS Power Module (Basler P/N: 9 2849 00 101) is included to interface between the PMG or the generator output and the DECS power input. Basler Electric recommends external fusing of the power input with Bussman type KTK-20 or equivalent fuses.

### Paralleling Input

The DECS comes equipped with paralleling provisions as standard. The Paralleling Input terminals are labeled CTB1 and CTB2. If paralleling is desired, connect the leads from a standard 1 A OR 5 A, 1 VA, 5P5, current transformer to these terminals. For cross current (reactive differential), see Figure 3-11.

- (1) One standard for generator phase rotation is A-B-C. With this phase rotation and three-phase sensing, connect the Generator leads as follows:

| Generator Phase | DECS Terminal |
|-----------------|---------------|
| A               | E1            |
| B               | E2            |
| C               | E3            |

The Paralleling Transformer must be in the Generator Phase B lead with the H1 towards the Generator and the X1 to DECS terminal CTB1.

- (2) Another standard for generator phase rotation is A-C-B. With this phase rotation and three-phase sensing, connect the Generator leads as follows:

| Generator Phase | DECS Terminal |
|-----------------|---------------|
| A               | E1            |
| B               | E3            |
| C               | E2            |

The Paralleling Transformer must be in the Generator Phase C lead with the H1 towards the Generator and the X1 to DECS terminal CTB1.

- (3) With single-phase sensing, connect the generator lead as follows:

| Generator Phase | DECS Terminal |
|-----------------|---------------|
| A               | E1            |
| C               | E2 & E3       |

The Paralleling Transformer must be in the Generator Phase B lead with the H1 towards the Generator and the X1 to the DECS terminal CTB1.

- (4) If a Unit/Paralleling Switch is desired, this switch or contacts are connected to the DECS terminals 52M and 52L. Paralleling is activated when the DECS terminals 52M and 52L are open. Paralleling is disabled when the terminals are shorted. Refer to the following chart.

| Operation Mode                           | 52 J-K | 52 L-M |
|--|--------|--------|
| Droop Mode Active                        | closed | open   |
| Voltage Mode Active, NO DROOP, NO VAR/PF | closed | closed |
| VAR/PF Active                            | open   | closed |
| VAR/PF Active (version 1.4.4 or later)*  | open   | open   |

\*This mode is not allowed for versions 1.4.3 or earlier. For versions 2.0.5 or later, it is recommended that Droop Mode be active when VAR/PF is active.

**CAUTION**

**For versions 1.4.3 or earlier, inputs 52 J-K and 52 L-M must not be left open simultaneously, even momentarily, or erratic operation may result.**

(5) The Current Transformer used for paralleling may also be used for Generator Output Current metering.

#### Field Flashing

When the DECS is powered by a PMG, field flashing is not required or necessary. If the unit is connected as a standard shunt exciter (non-PMG), and generator residual voltage is such that the input to the power module drops below 8 Vac, field flashing may be needed. If needed, conventional field flashing circuits may be used.

#### Voltage Matching Input

The standard DECS is equipped with an input for a utility or bus side voltage input. There are two terminals for this input. They are labeled BUS1 and BUS3. This input can accept up to 660 Vac directly. Above 660 Vac an appropriate transformer must be used. In the following typical connection diagrams (Figures 3-7 through 3-10), switch S3, when closed, provides the voltage matching input. Switch S3 should be open to disable voltage matching after the generator is paralleled.

A. TYPICAL CONNECTION (PMG APPLICATION, A-B-C ROTATION) THREE PHASE SENSING

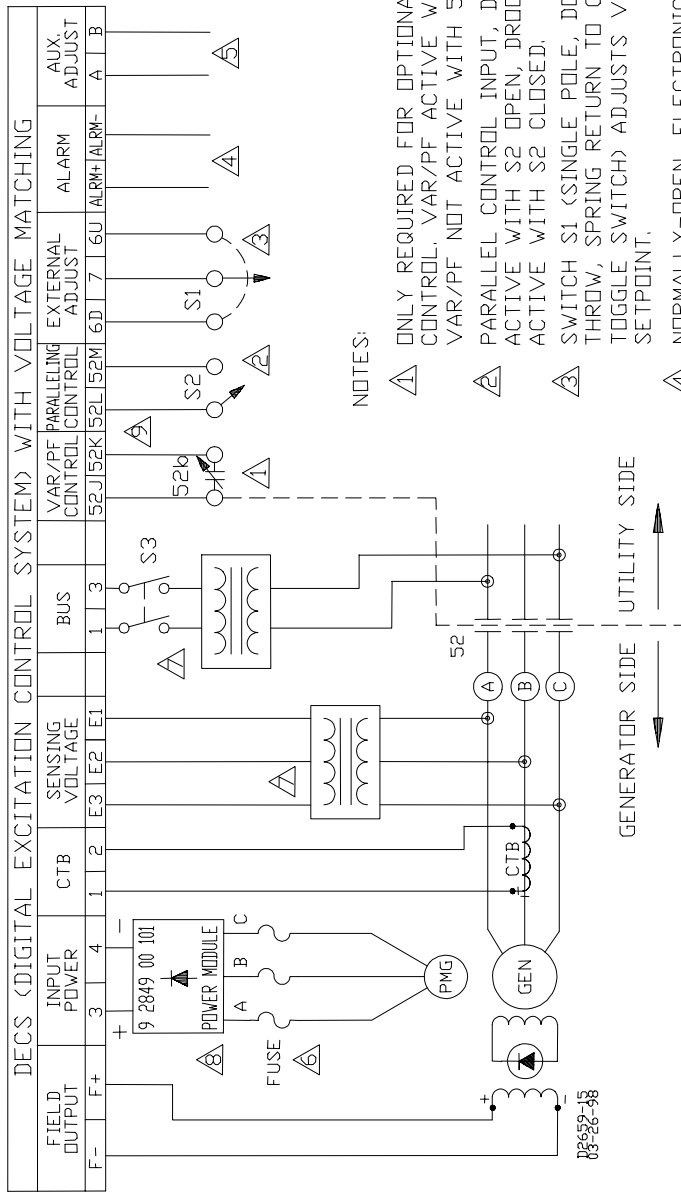

NOTES:

- ① ONLY REQUIRED FOR OPTIONAL VAR/PF CONTROL. VAR/PF ACTIVE WITH 52b OPEN, VAR/PF NOT ACTIVE WITH 52b CLOSED.
- ② PARALLEL CONTROL INPUT, DROOP ACTIVE WITH S2 OPEN, DROOP NOT ACTIVE WITH S2 CLOSED.
- ③ SWITCH S1 (SINGLE POLE, DOUBLE THROW, SPRING RETURN TO CENTER OFF TOGGLE SWITCH) ADJUSTS VOLTAGE SETPOINT.
- ④ NORMALLY-OPEN, ELECTRONICALLY CLOSED TRIAC INPUT FOR CUSTOMER SUPPLIED SIGNAL FOR ANNUNCIATION.
- ⑤ ANALOG INPUT VOLTAGE BETWEEN + OR - 3 VDC. ADJUSTMENT FOR VOLTAGE SETPOINT. REFER TO TABLE 2-1.
- ⑥ RECOMMENDED EXTERNAL FUSES SHOULD BE BUSSMAN TYPE KTK-20 OR EQUIVALENT.
- ⑦ SENSING POTENTIAL TRANSFORMER REQUIRED IF LINE VOLTAGE EXCEEDS 660 Vac.
- ⑧ SHOWN WITH 3 PHASE PMG. FOR SINGLE PHASE PMG, OMIT B-PHASE CONNECTION.
- ⑨ REFER TO TABLE 4-4.

Figure 3-7. Typical Connection (PMG Application, A-B-C Rotation) Three Phase Sensing

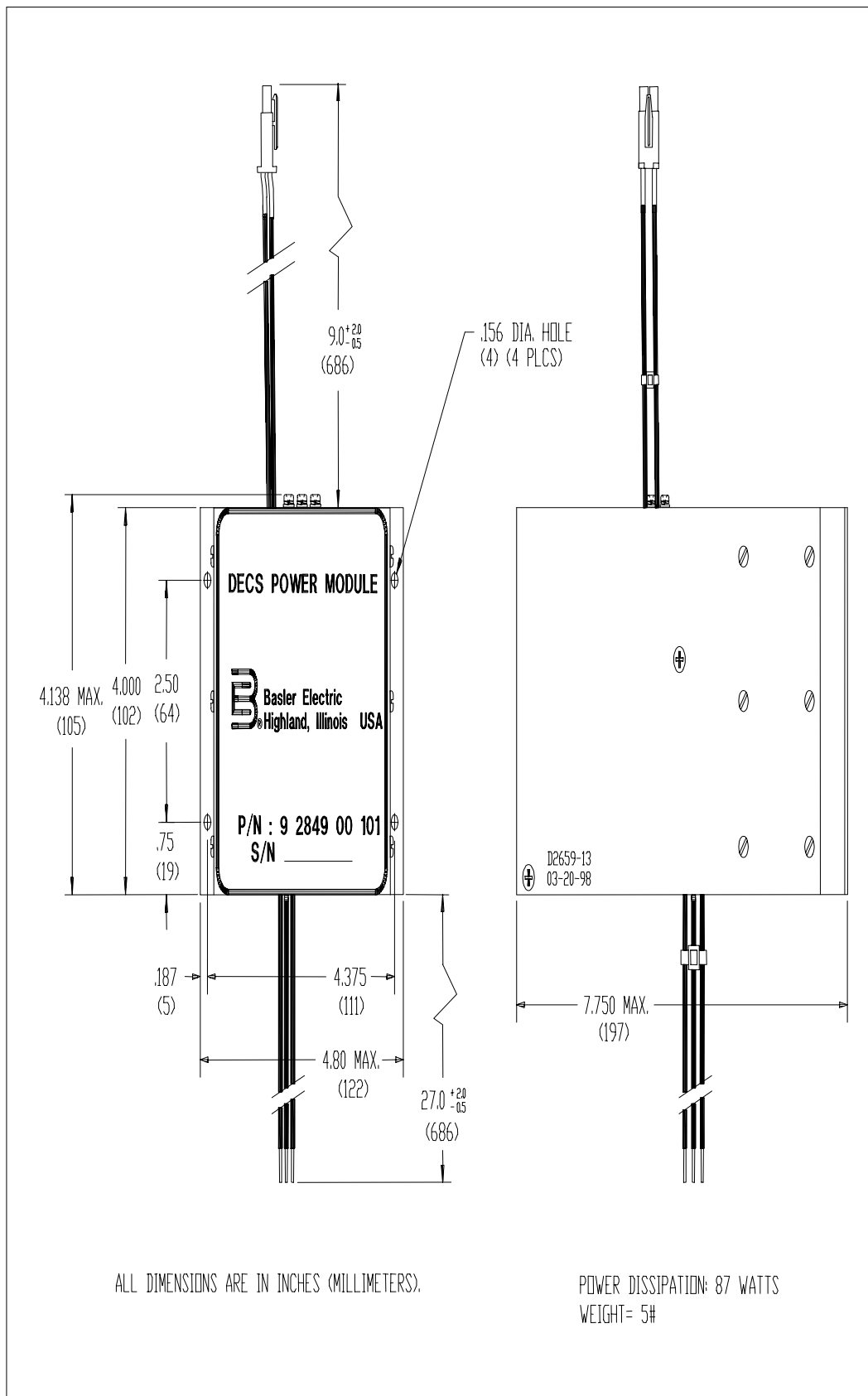

Figure 3-8. Typical Connection (Shunt Application, A-B-C Rotation) Three Phase Sensing

C. TYPICAL CONNECTION (PMG APPLICATION, A-B-C ROTATION) SINGLE PHASE SENSING

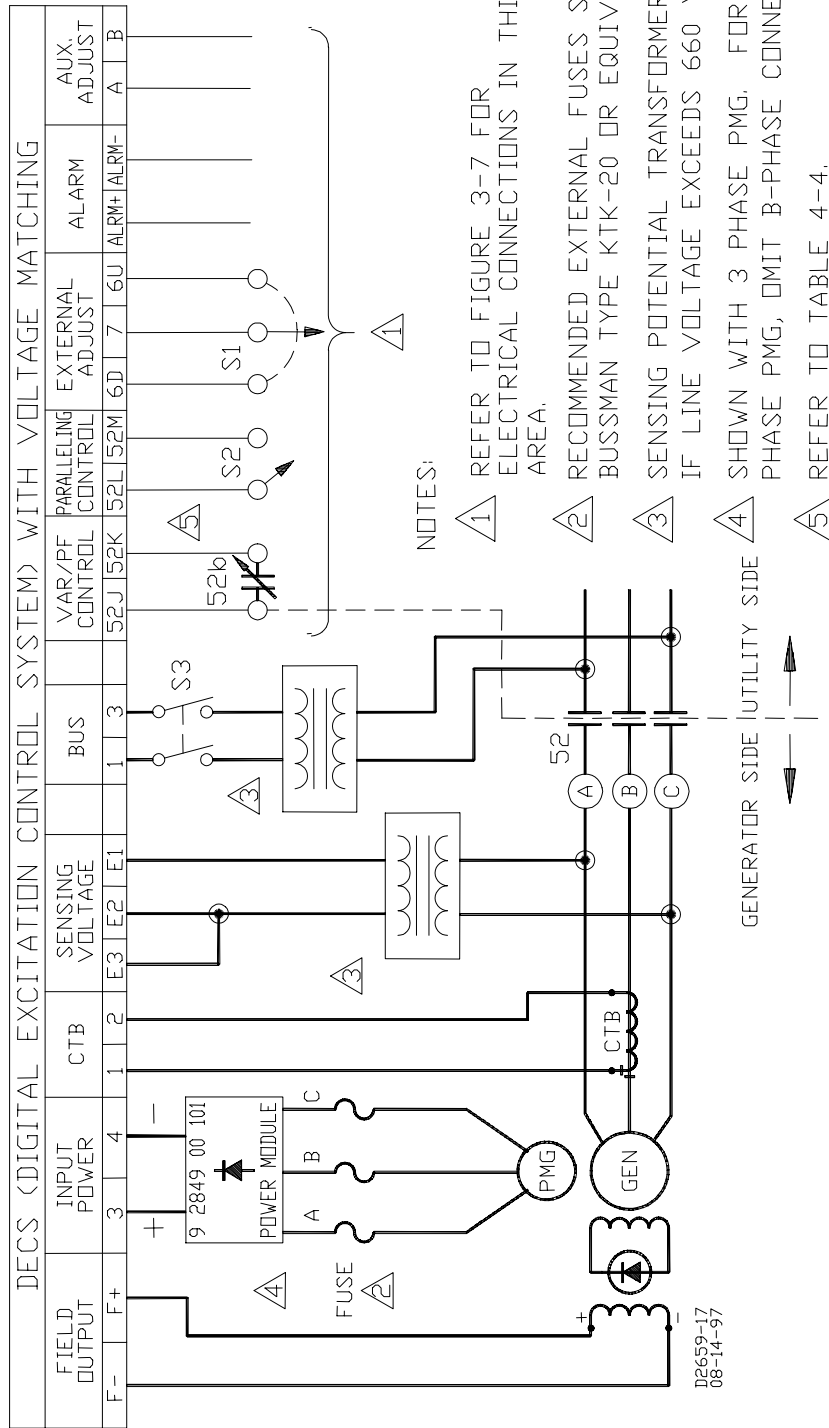

Figure 3-9. Typical Connection (PMG Application, A-B-C Rotation) Single Phase Sensing



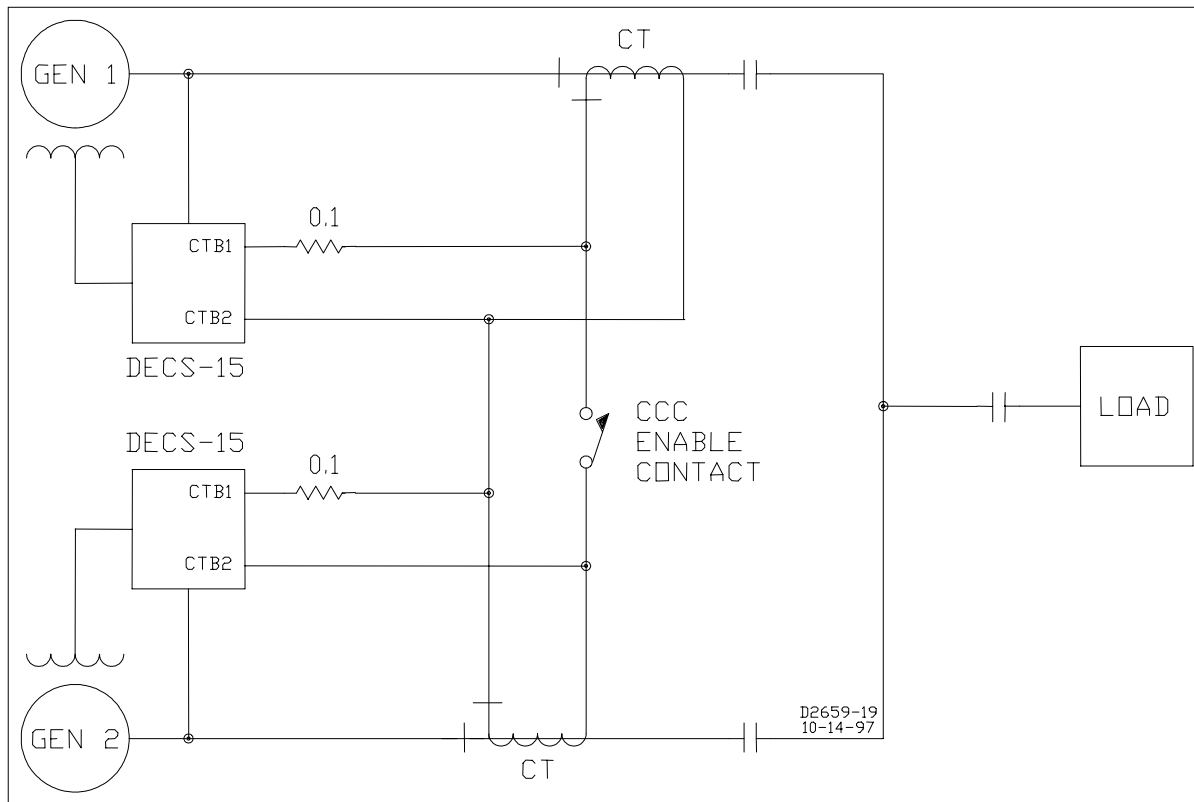

Figure 3-11. Cross Current (Reactive Differential) Connection

# SECTION 4 • OPERATION

## GENERAL

Refer to Figure 4-1 for the front panel controls and indicators. All adjustments are made either using external switching, the pushbuttons located on the DECS front panel, or via the serial link should the optional DECS Communication Interface Module (DCIM) P/N: 9 2745 00 101 be used.

The three front panel pushbuttons are:

- **SELECT** - Systematically selects the adjustment feature by successive presses of the button.
- **UP** - Increases the level of the selected adjustment feature.
- **DOWN** - Decreases the level of the selected adjustment feature.

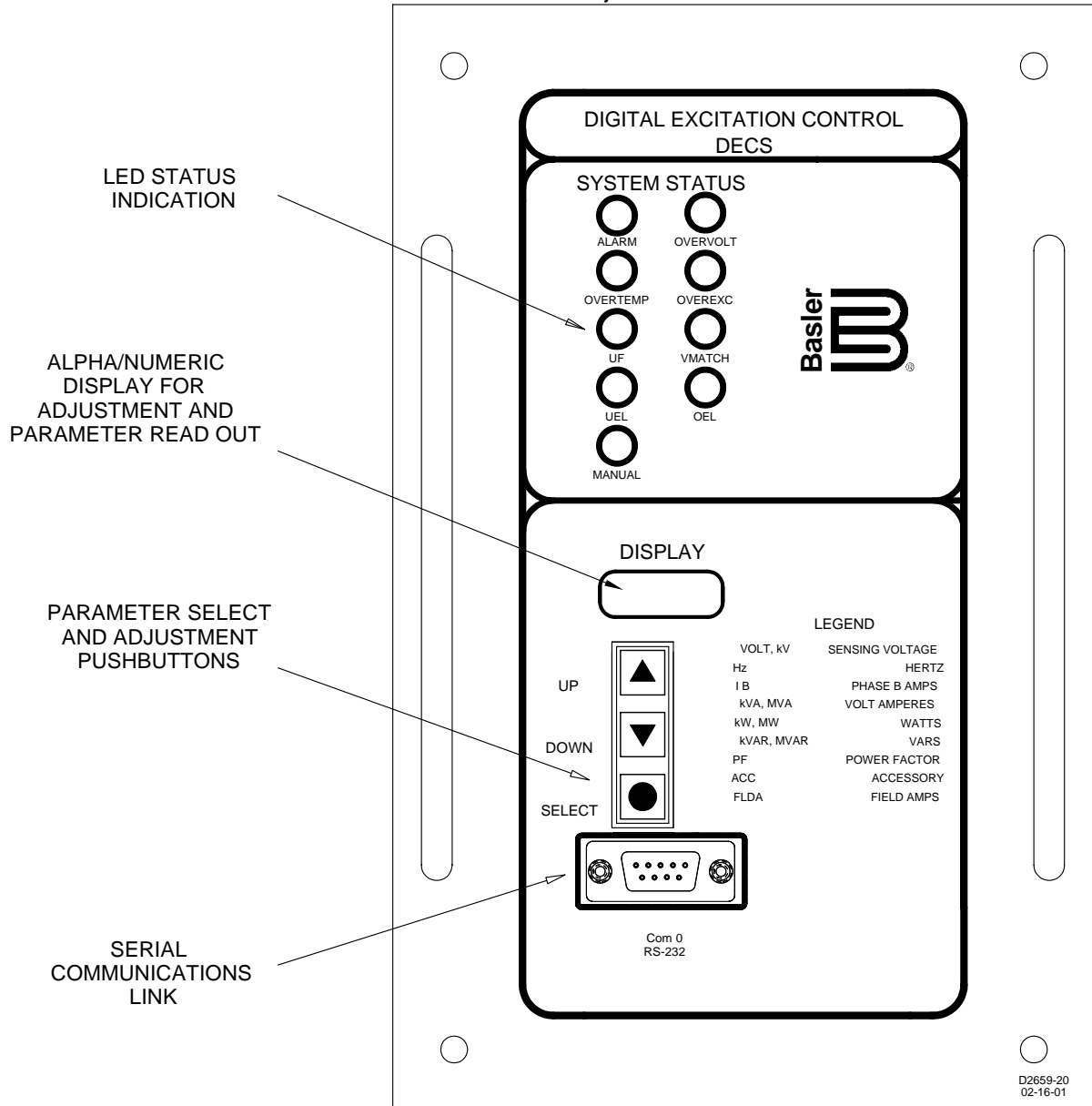

Figure 4-1. Front Panel Controls and Indicators  
(Standard DECS is shown for reference only.)

Successive presses of the front panel **SELECT** button will step through the various adjustment features. Once the desired adjustment feature is reached, the front panel **UP/DOWN** buttons will increase or decrease the level of the adjustment feature selected. Once the proper level is attained, the **SELECT** button must be pressed once more in order to save the new level in memory.

While in **SELECT** mode, if no button is pressed for a period of one minute, the DECS will automatically save the new level into memory. If input power to the DECS is interrupted before the automatic save function is enabled, the previous adjustment level will be the one recalled on the next power-up. The new level will not have been saved.

The **SELECT** button must be pressed in order to step through the adjustment features. The **UP** and **DOWN** buttons may then be successively pressed to increase or decrease the level. If either button is held down, the level will automatically increase or decrease at a rate of two increments per second. IF at any time both the **UP** and **DOWN** buttons are pressed simultaneously, the **UP** button will take precedence.

Refer to Table 4-1 for the front panel adjustments available on the DECS: The "Acronym" column in the table shows the acronym that will appear in the front panel display.

*Table 4-1. DECS Front Panel Adjustments*

| <b>Adjustments</b>              | <b>Acronym</b> |
|---------------------------------|----------------|
| Coarse Voltage                  | CV             |
| Fine Voltage                    | FV             |
| Fine Voltage Adjust Band        | FVAB           |
| Voltage Matching                | VMAT           |
| Voltage Matching                | BAND           |
| Voltage Matching Speed          | MSPD           |
| Voltage Matching Step           | MSTP           |
| Manual Mode Switch              | MANL           |
| Manual Mode Setpoint            | MANL           |
| Underfrequency Setpoint         | UF             |
| Volts/Hertz Slope               | V/HZ           |
| Stability Range                 | SR             |
| Stability Adjustment            | STAB           |
| Power Factor Mode Switch        | PF             |
| Power Factor Setpoint           | PF             |
| VAR Mode Switch                 | VAR            |
| VAR Mode Setpoint               | VAR            |
| Droop Adjust                    | DRP            |
| Under Excitation Limit          | UEL            |
| Overexcitation Select           | OES            |
| Overexcitation Time Delay #1    | OET1           |
| Overexcitation Current Limit #2 | OEI2           |

| Adjustments                     | Acronym |
|---------------------------------|---------|
| Overexcitation Time Delay #2    | OET2    |
| Overexcitation Current Limit #3 | OEI3    |
| Soft Start                      | SFST    |
| Sensing Configuration           | SNSE    |
| CT Rating                       | CT R    |
| PT Ratio                        | PT R    |

---

## PRELIMINARY SET-UP

Before starting the generator and DECS for the first time, proceed as follows:

- a. Tag and disconnect all wiring to the DECS. Be sure to insulate the wire terminals to prevent a short.
- b. Start the prime mover and perform all engine governor adjustments.
- c. After all initial governor adjustments have been made, shut down the prime mover.
- d. Connect **only** the power input leads of the DECS Power Module to an auxiliary power source of 120 Vac for DECS 32-15 or DECS 63-15, or 240 Vac, for DECS 125-15, 50/60 Hz, 1 Amp.
- e. Perform all initial adjustments as described in the following paragraphs. Use the front panel **SELECT** button and the **UP** and **DOWN** buttons. If desired, these adjustments can be made via the serial link with the DECS Communication Interface Module (DCIM) and the users' IBM-compatible (386 or better) PC.
- f. Connect the rest of the DECS leads using the tagged identification.
- g. Start the prime mover/generator and perform the final adjustments at rated speed and load.
- h. After the initial start-up, the DECS should not require any further adjustments unless there is a change in the system. If desired, the user's final settings may be recorded for future reference upon the included, shipped-loose, "settings label".

---

## ADJUSTMENTS

The sub-paragraphs below describe each adjustment that can be made to the DECS from its front panel. Refer to Table 4-1 for the display acronyms that will be displayed when each adjustment is selected. Table 4-2 lists the factory default settings for each adjustment. To access the Adjustment Menu, proceed as follows:

1. Press the front panel SELECT button until MENU is displayed in the alphanumeric display.
2. Press the front panel UP button to display MENU 1.
3. Press the front panel SELECT button to access the various adjustable features as described below.
4. After each adjustment is complete, press SELECT once more to save the new setting in memory and to progress to the next adjustment.

### COARSE VOLTAGE Adjustment (CV)

To select the Coarse Voltage Adjustment, press the front panel **SELECT** button until the acronym **CV** appears in the front panel display. Each up or down adjustment will increase or decrease the sensed generator output voltage by 6.0 Vac. The maximum range of the Coarse Voltage Adjust is from 0 to 660 Vac.

### FINE VOLTAGE Adjustment (FV)

To select the Fine Voltage Adjustment, press the front panel **SELECT** button until the acronym **FV** appears in the front panel display. Each up or down adjustment of the Fine Voltage Adjust will increase or decrease the sensed generator output voltage by 0.5 Vac. The range of the Fine Voltage Adjust is  $\pm 60$  Vac. Thus, the total range is 120 Vac from minimum to maximum of the sensed voltage.

### FINE VOLTAGE ADJUST BAND (FVAB)

This adjustment is accessed similarly through the front panel, and is provided to allow the customer to establish his preferred upper and lower boundaries around the Fine Voltage Adjust setpoint. The intention is to limit the range of adjustment about a selected setpoint. It is also used for the upper and lower boundaries of the voltage correction of the VAR and PF controller. The adjustment's range is from 6 to 60 in integer steps. It may be necessary to adjust the Fine Voltage setpoint to realize the preferred upper and lower boundaries.

A setting of "12" means that the band has a range of  $\pm 12$  Volts around the generator voltage setpoint.

For example: Generator Voltage: 120 Vac  
FVAB: 12  
Max. Voltage: 132 Vac  
Min. Voltage: 108 Vac

### MANUAL MODE SWITCH

This feature enables/disables the manual mode of control. When in the manual mode, the operator must adjust excitation for any load variations on the generator.

To enable the manual mode, press the **SELECT** button until the **MANL** appears on the front panel. The display will indicate if the manual mode is ON or OFF. Use the **UP** or **DOWN** buttons until the proper condition is obtained.

#### **WARNING**

The manual mode excitation level must be evaluated prior to enabling this feature. If the level of excitation current is inappropriate for the generator loading, severe damage to the generator may occur.

### MANUAL MODE SETPOINT

To select the level of excitation current in the manual mode, press the select button until **MANL** appears on the front panel. Use the **UP** or **DOWN** buttons to obtain the appropriate level of excitation. The range of this mode is from 0 to 25 Amps dc. Care must be taken not to exceed 15 Amps on a continuous basis and 20 Amps dc for more than 20 seconds. Damage to the DECS unit or the generator may occur if excitation levels are exceeded for any period of time.

### UNDERFREQUENCY (UF)

The Underfrequency adjustment changes the frequency at which the DECS begins to operate on a constant volts/Hertz ramp. The adjustment range is from 40 to 65 Hertz. Increasing the adjustment will increase (raise) the transition frequency in 0.1 Hz steps. Decreasing the adjustment will decrease (lower) the transition frequency in 0.1 Hz steps. To select the Underfrequency adjustment, press the front panel **SELECT** button until the acronym **UF** appears on the front panel display. The display will also indicate the current transition level in Hertz. If another transition level is desired, press the front panel **UP** or **DOWN** buttons until the desired level is attained.

### VOLTS PER HERTZ SLOPE (V/Hz)

This adjustment allows the user to set the slope of the Volts per Hertz line of the DECS. The range of V/Hz adjustment is from 0.0 to 3.0 per unit V/Hz in 0.1 per unit V/Hz steps.

### STABILITY RANGE SELECT (SR)

The first step in acquiring stable generator output is to select the appropriate stability range, or "stability network", for the frame size of the generator and the excitation system used. A guide for selecting the Stability Range setting is provided by Table 4-3. By successively pressing the **SELECT** button on the front panel, **SR** will be displayed. With every push of the **UP** or **DOWN** buttons, the stability range setting can be changed. After selecting a stability range, the DECS will automatically load a preset stability level that should be acceptable for most applications.

### STABILITY LEVEL ADJUSTMENT (STAB)

Adjusting the stability level within each stability range up or down will increase or decrease respectively the gain of the DECS, which, in turn, will increase or decrease the response time of the system. Adjusting the stability level is analogous to "turning a stability potentiometer" in a conventional voltage regulator. This adjustment is the fine gain adjustment of the DECS unit, and allows the user to modify the stability to suit his specific needs. A higher value of **STAB** gives a more stable performance along with a more sluggish response than would a lower value of **STAB**. **STAB** has a scaled range of 0 (least stable/fastest response) to 250 (most stable/slowest response).

To select the Stability Level Adjustment, press the **SELECT** button until **STAB** appears on the front panel display. The display will indicate the present relative level of stability. If another level is desired, press the front panel **UP** or **DOWN** buttons until the proper level is attained.

Instability is best observed by monitoring the generator output voltage. Do not try to monitor the DC field voltage. Even when the generator output voltage is stable, a DC voltmeter will show small fluctuations in the field voltage. If instability is seen in the generator output, proceed as follows:

- a. Operate the generator under no-load conditions.
- b. Select an appropriate stability range (**SR**) for the generator being tested. Refer to Table 4-3.
- c. Adjust the Stability Level (**STAB**) as required that provides acceptable no-load stability.
- d. Apply load. If the generator remains stable and the system response is acceptable, no further adjustment is needed. If the generator is still unstable, increase the Stability Level by pressing the **UP** button until satisfactory stability is attained.
- e. Reject and apply the load one or two more times. The generator should remain stable.
- f. If the generator is not stable, or if the system response time is too slow, then adjust the stability level one or two increments at a time. Apply and reject the load after each adjustment until optimum performance is achieved.
- g. If the generator is still unstable, recheck the appropriateness of the selected Stability Range (**SR**) and reselect if required. Retest any adjustments.
- h. If the generator is still unstable and every other stability-bearing variable has been verified, then a custom stability range may be required. Call the factory, and order Basler Electric P/N: 9 2745 00 101, "DECS Communication Interface Module" (DCIM), to facilitate establishing an application-specific stability range.

Table 4-2. Factory Default Settings

| <b>Adjustment Acronym</b> | <b>Setting</b> |
|---------------------------|----------------|
| CV                        | 80 Vac         |
| FV                        | 80.0 Vac       |
| FVAB                      | 10 Vac         |
| UF                        | 50.1 Hz        |
| V/Hz                      | 1.0 V/Hz       |
| SR                        | 1              |
| STAB                      | 196            |
| PF                        | 1.0            |
| VAR                       | +7%            |
| DRP                       | 0.0%           |
| UEL                       | 20%            |
| OES                       | OFF            |
| OET1                      | 10 sec.        |
| OEI2                      | 20 Amps        |
| OET2                      | 120 sec.       |
| OEI3                      | 15 Amps        |
| SFST                      | 2              |
| SNSE                      | ABC rotation   |
| CT R                      | 1              |
| PT R                      | 1.0            |
| VMAT                      | OFF            |
| BAND                      | 20%            |
| MSPD                      | 2              |
| MSTP                      | 2              |
| MANL                      | OFF            |
| MANL                      | 1.0 Amps       |

Table 4-3. Stability Range Settings For DECS As Accessed Through The Front Panel

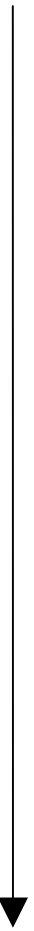
| Generator Size   | Generator Data                         |                                   |                     | Stability Range |
|--|--|-----------------------------------|---------------------|-----------------|
|  | Gen. Open Circuit Time Constant (T'dO) | Gen. Exciter Time Constant (Texc) | Generator Frequency |                 |
| Small<br><br>Large | 1.0 Seconds                            | 0.17 Seconds                      | 50 Hz               | 0               |
|  | 1.0 Seconds                            | 0.17 Seconds                      | 60 Hz               | 1               |
|  | 1.5 Seconds                            | 0.25 Seconds                      | 50 Hz               | 2               |
|  | 1.5 Seconds                            | 0.25 Seconds                      | 60 Hz               | 3               |
|  | 2.0 Seconds                            | 0.33 Seconds                      | 50 Hz               | 4               |
|  | 2.0 Seconds                            | 0.33 Seconds                      | 60 Hz               | 5               |
|  | 2.5 Seconds                            | 0.42 Seconds                      | 50 Hz               | 6               |
|  | 2.5 Seconds                            | 0.42 Seconds                      | 60 Hz               | 7               |
|  | 3.0 Seconds                            | 0.50 Seconds                      | 50 Hz               | 8               |
|  | 3.0 Seconds                            | 0.50 Seconds                      | 60 Hz               | 9               |
|  | 3.5 Seconds                            | 0.58 Seconds                      | 50 Hz               | 10              |
|  | 3.5 Seconds                            | 0.58 Seconds                      | 60 Hz               | 11              |
|  | 4.0 Seconds                            | 0.67 Seconds                      | 50 Hz               | 12              |
|  | 4.0 Seconds                            | 0.67 Seconds                      | 60 Hz               | 13              |
|  | 5.0 Seconds                            | 0.83 Seconds                      | 50 Hz               | 14              |
|  | 5.0 Seconds                            | 0.83 Seconds                      | 60 Hz               | 15              |
|  | 5.5 Seconds                            | 0.92 Seconds                      | 50 Hz               | 16              |
|  | 5.5 Seconds                            | 0.92 Seconds                      | 60 Hz               | 17              |
|  | 6.0 Seconds                            | 1.00 Seconds                      | 50 Hz               | 18              |
| 6.0 Seconds  | 1.00 Seconds                           | 60 Hz                             | 19                  |                 |

### (OPTIONAL) VAR/POWER FACTOR ADJUSTMENTS (VAR or PF)

The **VAR/PF** is an optional feature and is used when paralleling a generator to a utility. It is only available with models DECS 32/63/125-15-BXX. If it has not been purchased, it cannot be selected. The **PF** range is from -0.6 to +0.5 in 0.01 steps. A -0.8 Power Factor setting means that the generator is set to operate at a 0.8 leading (underexcited) power factor condition. A +0.8 Power Factor setting means the generator is set to operate at a 0.8 lagging (overexcited) power factor condition.

The **VAR** adjustment affects the Volt Amp Reactive power setpoint. The range is from -100 to 0 to 100% of the 1 Amp C.T. input to the DECS unit. It is adjustable in integer steps. If the DECS receives a 1 Amp C.T. signal from the phase B C.T., and the VAR setpoint is at +100, then the DECS would be exporting 100% reactive power (Var's). A setpoint of -100 indicates the DECS would be importing VAR's.

Increasing the level of **VARs** or the **PF** will increase the amount of field excitation. Conversely, decreasing the level of **VARs** or the **PF** will decrease the amount of field excitation.

The **VAR/PF** feature has two states: (a) Inactive. The feature is available, but is disabled by shorting a set of contacts across terminals 52J and 52K. (b) Active. The feature is available and active when terminals 52J and 52K are not shorted.

Table 4-4.

| Operation Mode                           | 52 J-K | 52 L-M |
|--|--------|--------|
| Droop Mode Active                        | closed | open   |
| Voltage Mode Active, NO DROOP, NO VAR/PF | closed | closed |
| VAR/PF Active                            | open   | closed |
| VAR/PF Active (version 1.4.4 or later)*  | open   | open   |

\*This mode is not allowed for versions 1.4.3 or earlier. For versions 2.0.5 or later, it is recommended that Droop Mode be active when VAR/PF is active.

To select **VAR** or **PF** control adjustment, press the front panel **SELECT** button until the desired adjustment acronym is displayed. The display will also indicate whether the feature is active (**ON** or **OFF**), and the relative level of adjustment present. If another level is desired, press the **UP** or **DOWN** buttons until the desired setting is acquired.

### DROOP ADJUSTMENT (DRP)

The Droop Adjustment is used when paralleling generators. The settings range from 0% to 20% droop in 0.5% steps. Increasing the **DRP** level will increase the amount of generator voltage droop with the application of a reactive load. A 1 or 5 amp signal from a 1 or 5 VA, 5P5 current transformer (CT) into DECS terminals CTB1 and CTB2 will give approximately a 20% voltage droop with the application of a 0 PF load and the **DRP** adjustment level set to maximum.

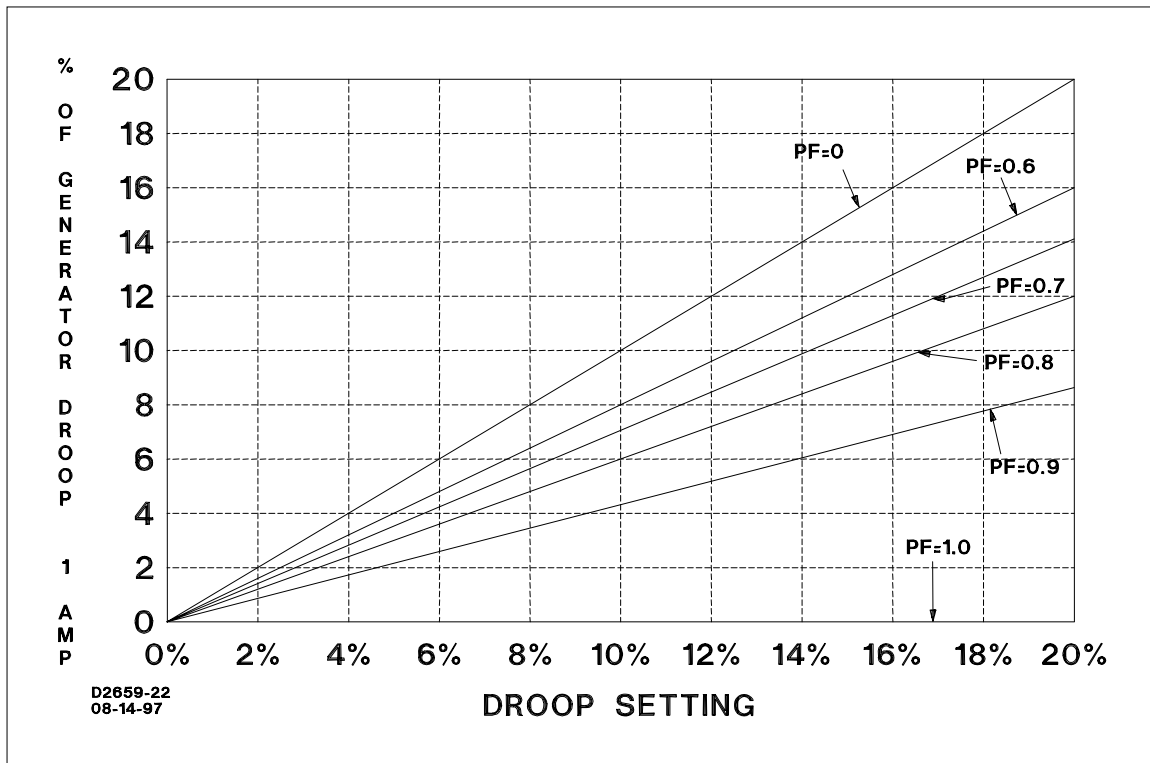

Figure 4-2. % GENERATOR DROOP VS DROOP SETTING AT DIFFERENT POWER FACTOR LOADS

The **DRP** feature has two states: (a) Inactive. The feature is available, but is disabled by shorting a set of contacts across terminals 52L and 52M. (b) Active. The feature is available and is active when terminals 52L and 52M are not shorted. Refer to Table 4-4 for other input connection considerations.

To select the Droop adjustment, press the front panel **SELECT** button until **DRP** appears on the front panel display along with the present, relative droop level. If another level of droop is desired, press the front panel **UP** or **DOWN** buttons until the desired level is acquired.

The best method of setting the droop level is to first operate each generator individually (non-paralleled) and apply rated or near-rated current at a +0.8 PF. The amount of droop for each generator can be set based upon the instruction above. An alternate method of setting the droop is as follows:

- a. Ensure the prime mover is stopped and that all power is off before proceeding any further.
- b. With the droop CT installed into the generator Phase B lead, temporarily connect the generator E1 sensing lead to the generator Phase B lead. Connect the E2 and E3 sensing leads to generator Phase A lead.
- c. Operate each generator individually (non-paralleled) and apply rated or near-rated load at unity (1.0) PF. The amount of droop can then be set by adjusting the Droop adjustment as needed for the application.
- d. If, when adjusting the generator droop, the generator output voltage does not decrease with the application of load, recheck the CT polarity and the sensing lead connections.
- e. After completing the droop adjustments, reconnect the DECS sensing leads to the appropriate configuration as determined by one of the interconnect diagrams on Figures 3-7 through 3-10.

When the generators are operated in parallel, they will share the load equally. If no reactive load is present, the generator voltage should not droop. If it does droop, recheck the sensing connections, the CT connections, and CT polarity. If needed, repeat the adjustment procedure.

For cross current or reactive differential compensation, a series resistor must be used for proper current sharing. (See Figure 3-11.)

#### OPTIONAL UNDEREXCITATION LIMITING/OVEREXCITATION LIMITING (UEL/OEL)

The Over and Under Excitation limiters will establish and maintain a safe level of excitation for the generator. They will not allow the excitation to drop to a level where the generator could slip out of synchronization nor will they allow the generator to be overexcited to the point of damaging the generator field windings.

#### **CAUTION**

**For versions 1.6.0 or earlier, when UEL is used, auto ranging of the sensing input must be disabled via DCIM interface.**

The adjustable level of reactive current, for the Under Excitation Limiter, is from 1 to 80% of the maximum reactive current rating of the generator. The UEL is only active while in the DROOP, PF or VAR mode. The front panel UEL LED will illuminate whenever the reactive current exceeds the programmed level. When the reactive current decreases below the programmed level, the UEL LED will extinguish. To adjust the UEL setpoint, press the front panel SELECT button until the UEL acronym appears in the display. Subsequent presses of the UP or DOWN buttons will adjust the point at which the UEL activates.

The Over Excitation Limiter has three regions of operation. Refer to Figure 1-3. Region 1 is fixed at a maximum of 30 Adc. The timing for this region starts anytime the current level of OEI3 is exceeded. The timing is adjustable in Region 1 by the OET1 setting. OET1 is adjustable from 0 to 10 seconds. Once OET1 expires, the dc excitation current is driven down to the level as set by OEI2.

The time delay for Region 2 is adjustable by OET2. This adjustment is from 0 to 120 seconds, starting upon the expiration of OET1. The current level of Region 2 is set by OEI2. This is adjustable from 1 to 20 Adc. If the dc current level exceeds the OEI2 setting and remains there until OET2 expires, then the dc current is driven down to the level as set by OEI3.

The dc excitation current will remain at the level of OEI3 continuously until the fault is cleared by external means. OEI3 is adjustable from 1 to 15 Adc.

Overexcitation current limiting will occur whenever OEI3 is exceeded, which is indicated by the front panel OEL LED illuminating. The OEL action will halt once the field current drops 1 Amp below the field current limiting setpoint. To adjust the OEI/OET setpoints, press the front panel SELECT button until the appropriate acronym appears on the front panel display along with its present relative setpoint. Subsequent presses of the UP or DOWN buttons will adjust the setpoint value.<sup>3</sup>

#### (OPTIONAL) OVEREXCITATION SELECT (OES)

This optional feature is integral with the **OEL** feature and allows the user to enable or disable the **OEL**. "Enabled" is indicated with a "1", and "disabled" is indicated with a "0". To change the state of **OES**, press the front panel select button until the acronym **OES** appears on the front panel display. By pressing the **UP** or **DOWN** buttons, the state can be toggled.

#### SOFTSTART (SFST)

The DECS provides the user the opportunity to set how fast the DECS unit will bring up the generator's voltage to the "generator voltage setting". The scaled range of adjustment is from "0", which will be the slowest rate of voltage build-up, to "99", which will be the fastest. To adjust the softstart rate, press the **SELECT** button until the acronym **SFST** appears on the front panel display. Subsequent presses of the **UP** or **DOWN** buttons will adjust the softstart rate to the desired setting.

### DECS SENSING CONFIGURATION (SNSE)

This adjustment allows the user to configure the DECS for either single- or three-phase sensing. The factory default setting is for three-phase sensing with A-B-C rotation. However, the user can select A-C-B rotation as well as single-phase sensing. When selecting single-phase sensing, inputs E2 and E3 must be connected to Phase C of the generator output. (Refer to Figures 3-9, 3-10 for single-phase sensing interconnection.) Single-phase sensing has been selected when "A-C" is displayed on the front panel display.

To access this adjustment, press the **SELECT** button until the acronym **SNSE** appears on the front panel display. Subsequent presses of the **UP** or **DOWN** buttons will change the setting from ABC to ACB to A-C. Once the desired sensing configuration has been selected, press the **SELECT** button once more to save the setting in memory.

### CURRENT TRANSFORMER PRIMARY RATNG(CT R)

This adjustment allows the user to set the current transformer primary rating. It has a range from 1 to 5000 in single integer steps. As an example, if the DECS is style DECS XX-15-XXX1-VXX and the system current transformer steps the current down from 200 A to 1 A, then the current transformer primary rating should be set to 200. Similarly, if the DECS is style DECS XX-15-XXX5-VXX and the system current transformer steps the current down from 200 A to 5 A, then the current transformer primary rating should be set to 200. To access this adjustment, press the **SELECT** button until the acronym **CT R** is displayed on the front panel. To adjust the setting, press the **UP** or **DOWN** buttons until the desired setting has been acquired.

### SENSING POTENTIAL TRANSFORMER RATIO (PT R)

This adjustment allows the user to set the sensing transformer ratio. It has a range of adjustment from 0.1 to 99.9 in 0.1 steps and 100 to 200 in 1.0 steps. It is used so that the displayed voltage of the DECS will match the actual generator output voltage. For example, if the system has a sensing potential transformer that steps the voltage down from 3300 Vac to 100 Vac, then the sensing potential transformer ratio (**PT R**) should be set to 33.0. To access this adjustment, press the **SELECT** button until the acronym **PT R** is displayed on the front panel. To adjust the setting, press the **UP** or **DOWN** buttons until the desired setting has been acquired.

### VOLTAGE MATCHING (VMAT)

This feature is used to control the generator output prior to implementing conventional generator-to-utility synchronizing procedures. The **VMAT** option compares the generator and utility bus voltages, adjusts the generator output and once the voltages are within 1% of each other, then the **VMATCH** LED illuminates; thereby indicating to the user that he may commence synchronizing procedures. To enable the Voltage Matching option, press the **SELECT** button until the **VMAT** acronym appears on the front panel display. The factory default setting is **OFF**. By pressing the **UP** or **DOWN** buttons, the feature can be enabled (**ON**) or disabled (**OFF**).

### VOLTAGE MATCHING BAND (BAND)

This feature is used to set a band about the generator voltage setpoint within which the voltage matching feature will operate. The band width is adjustable with a range from 1% to 20% in 1% steps. For example, if the generator voltage setpoint is 120 Vac and the user sets the **BAND** value at 10, then the band limits are set at 10% above and 10% below 120 Vac. The upper limit would then be at 132 Vac, and the lower limit would be at 108 Vac with a nominal setpoint of 120 Vac. If the voltage at the DECS BUS1 and BUS3 inputs is outside of this band, then the **VOLTAGE MATCHING** feature will not operate. To access this adjustable feature, press the **SELECT** button until the acronym **BAND** appears on the front panel display. Subsequent presses of the **UP** or **DOWN** buttons will allow the user to set the desired band limits.

### VOLTAGE MATCHING SPEED (MSPD)

This adjustable feature is used to set the speed of the **VMAT** feature and has a scaled range from 1 to 20 in integer steps. A setting of 1 provides the slowest speed while a setting of 20 is the fastest.

To access this adjustment, press the **SELECT** button until the acronym **MSPD** appears on the front panel display. Subsequent presses of the **UP** or **DOWN** buttons allows the user to set **MSPD** value. The factory default setting is at 20.

#### VOLTAGE MATCHING STEP (MSTP)

This adjustable feature is used to set the size of the correction step in voltage matching mode. The range of this adjustment is from 1 to 8 in integer steps. A setting of 1 will provide voltage correction in 0.5 V steps. Similarly, a setting of 8 will provide 4.0 V steps. To access this adjustment, press the **SELECT** button until the acronym **MSTP** is displayed on the front panel. Subsequent presses of the **UP** or **DOWN** buttons will allow the user to determine his step setting.

---

## FRONT PANEL OPERATION

There are 4 parts to the DECS front panel:

- Nine status and diagnostic LED's provide continuous information about the operation of the DECS unit.
- A 4-character alphanumeric display is used for display and adjustments/set-up.
- A 3-button keypad allows for the selection of information to be displayed and entering of adjustments.
- A serial data link connection provides for computerized factory testing and field troubleshooting by Basler-trained engineers and technicians. It also provides a means to connect the DCIM for tuning various parameters for unique generator applications.

#### STATUS AND DIAGNOSTIC LED'S.

**Alarm LED.** The front panel red **ALARM** LED shows the status of the solid state Alarm Output triac. Small (0.15 Amp) AC and DC loads can be connected to this triac at the "ALRM+" and "ALRM-" terminals on the DECS unit.

Both hardware and software protective features control the Alarm triac operation. Overexcitation hardware in the DECS unit will turn on the Alarm Relay when generator field voltage exceeds a level preset in hardware for 15 seconds. Refer to Table 4-5.

*Table 4-5. Overexcitation Presets*

| DECS Model Number | Voltage Trip Point |
|-------------------|--------------------|
| DECS 32-15        | 50                 |
| DECS 63-15        | 100                |
| DECS 125-15       | 200                |

If the field voltage returns to a level below the voltage trip point preset in hardware, then the 15 second timer will reset to zero.

**OVEREXC LED.** The red **Overexcitation** LED is turned on when the observed field voltage exceeds a factory preset value (Refer to Table 4-5). Should the overexcitation condition last for 15 seconds, then the Alarm Relay and the front panel **ALARM** LED will be turned on.

**OVERVOLT LED.** The red **Overvoltage** LED is turned on whenever the generator output voltage exceeds 135%. If this overvoltage condition continues for 0.75 seconds, then the Alarm triac and the front panel **ALARM** LED will be turned on.

**OVERTEMP LED.** The red **Overtemperature** LED is turned on when the observed temperature of the power semiconductors exceeds a set limit. The DECS unit will also turn on the Alarm Relay and the front panel **ALARM** LED.

**UF LED.** The yellow **Underfrequency** LED displays the state of the underfrequency feature of the DECS unit. When the generator frequency falls below the underfrequency setpoint, the LED is turned on and the underfrequency features is activated.

**MANUAL LED.** This red LED will be illuminated anytime the manual excitation mode is enabled.

**UEL LED (Optional).** This LED will only operate with models DECS 32/63/125-15-X2C. The yellow **Under Excitation Limit** LED displays the state of the reactive current underexcitation limit features of the DECS unit. The DECS unit will keep the generator reactive current from going below a customer-selected minimum level. While the DECS unit is limiting, this LED will be turned on. The underexcitation limit is operational only when the DECS unit is in a parallel connection (52J-K is open or 52L-M is open).

**OEL LED (Optional).** This LED will only operate with models DECS 32/63/125-15-X2C. The yellow **Overexcitation Limit** LED displays the state of the field current overexcitation limit feature of the DECS unit. The DECS unit will keep the generator field current from going above a customer-selected maximum level. While the DECS unit is limiting, this LED will be turned on. This feature is operational whenever the field current has exceeded the OEI3 limit. Refer to Figure 1-2 for settings.

**VMATCH LED:** The yellow **Voltage Matching** LED displays the status of the Voltage Matching circuitry comparing the sensed generator voltage and the sensed utility bus voltage. Once the compared voltages are within 1% of each other, the LED illuminates; thereby indicating to the user that he may then initiate generator-to-utility synchronizing procedures. Once paralleled, the DECS reverts to **VAR/PF** control, and the **VMATCH** LED remains illuminated only as long as the compared voltages are within 1% of each other.

#### ALPHA NUMERIC DISPLAY

This 4 character display is used for 2 modes: display and adjustments: The DECS unit will power up in the display mode. In the display mode, the customer can step through a list of measured and calculated generator parameters by pressing the front panel **SELECT** button. The next entry on the metering list labeled "**MENU**" allows the customer to toggle between the display list and the adjustment list by pressing the up or down button. **MENU 1** will allow the user to access to the Adjustment List. Refer to Table 4-6 for the Display List and to Table 4-1 for the Adjustment List.

Table 4-6. Display List

| Display Acronym | Function/Value Displayed  |
|-----------------|---|
| VOLT            | True RMS value of the system three-phase or single-phase voltage. |
| Hz              | Generator frequency in Hertz.                                     |
| I B             | Phase B current in Amperes.                                       |
| kVA or MVA      | Apparent Power  |
| kW or MW        | Real Power  |
| kVAR or MVAR    | Reactive Power  |
| PF              | Power Factor  |
| ACC             | Accessory input in Volts.   |
| FLDA            | Field current in Amperes.   |
| MENU            | Allows selection of the display or adjustment list.               |

**CAUTION**

**Generator parameters are displayed to an accuracy of 10% of the full scale reading for each parameter. For greater accuracy of displayed information deemed critical to generator operation, external meters should be used.**

---

## **DECS COMMUNICATION INTERFACE MODULE (DCIM) AVAILABLE FEATURES P/N 9 2745 00 101**

Optional communications software is available to aid in the calibration and configuration of the DECS unit. The software option includes an interface module and software diskette. It is Part Number 9 2745 00 101. The DCIM contains a 9V battery. This device is required to select a specific sensing range, perform file transfers, select stability network PID values, perform step changes and to initiate the following features:

### DECS ALARM ENABLE/DISABLE

The DECS has been designed to provide an alarm indication and a triac closure for each of the following trouble conditions:

- Overtemperature of the DECS
- Overvoltage
- Overexcitation
- Underfrequency

The triac has been provided to allow the user to customize these alarm functions to suit his specific needs; such as remote alarm annunciation or various system relay trips.

The Overtemperature, Overvoltage, and Overexcitation alarm functions are factory preset and are enabled. The Underfrequency alarm function is disabled as shipped from the factory, but each and every alarm feature can be enabled or disabled by the customer if he chooses via the optional DECS Communication Interface Module (DCIM) and his IBM-compatible (386 or better) personal computer.

### DECS SHUTDOWN ENABLE/DISABLE

The DECS has been designed with inherent protective features that, if enabled, will shutdown the DECS field output and, hence, the excitation system. The trouble conditions monitored are identical to those for the DECS Alarm conditions:

- Overtemperature of the DECS
- Overvoltage
- Overexcitation
- Underfrequency

To allow the customer the greatest in flexibility, none of the above shutdown conditions are enabled from the factory. As is the case for the Alarm conditions, the customer can tailor these shutdown features to meet his specific needs via the optional DECS Communication Interface Module (DCIM) and an IBM-compatible (386 or better) personal computer. The shutdown conditions, if activated, are cleared and reset only if power to the DECS is cycled.

# SECTION 5 • MAINTENANCE

---

## PREVENTIVE MAINTENANCE

The only preventive maintenance required on the DECS is to periodically check the following:

- Be sure the connections between the DECS and the system are clean and tight.
  - Verify that the DECS cooling fins and housing are free from dust, dirt, and corrosion.
- 

## CORRECTIVE MAINTENANCE

The DECS has been designed for easy repair by replacement of electronic modules. Refer to Section 6 for the replacement parts list.

---

## WARRANTY AND REPAIR SERVICE

The Basler DECS is warranted against defective material and workmanship for 18 months from the date of shipment from our factory. Units submitted for warranty repair should be returned to the factory in Highland, Illinois, freight pre-paid, with a complete description of the installation and the reported problem. Pre-arrangement with either the nearest Basler Sales Office or with the Customer Service Department at the factory will assure the fastest possible turn-around time.

---

## TROUBLESHOOTING

The more common generator system malfunctions and the appropriate repair procedures are in the following paragraphs.

### NO VOLTAGE BUILD-UP

*Step 1.* Verify that all wiring is properly connected. Refer to Figure 3-7 through 3-11.

If wiring is improperly connected, loose, miswired, etc., reconnect wiring properly.

If wiring is properly connected, proceed to Step 2.

*Step 2.* Check for correct power input to the DECS. Refer to Table 1-2, "Power Input" requirements.

If voltage is not present, refer to generator manual for PMG repair (PMG system only).

If voltage is present, proceed to Step 3.

*Step 3.* Verify that all fuses are not open.

If any fuse is open, replace fuse.

If all fuses are not open, proceed to Step 4.

*Step 4.* Verify that generator is up to rated speed.

If generator is not up to rated speed, increase generator speed to rated.

If generator is up to rated speed, proceed to Step 5.

*Step 5.* If the DECS is being used in (non-PMG) mode, verify that the generator residual voltage is at least 8 Vac.

If the generator residual voltage is less than 8 Vac, refer to the generator manual and flash the generator field.

If the generator residual voltage is 8 Vac or greater, proceed to Step 6.

*Step 6.* Verify that the front panel OVEREXC (Overexcitation) LED is extinguished.

If the front panel OVEREXC LED is illuminated, check the generator and/or load conditions. Interrupt input power or shut down the generator for a minimum of 10 seconds.

If the front panel OVEREXC LED is not illuminated, proceed to Step 7.

*Step 7.* Verify that the front panel OVERVOLT (Overvoltage) LED is extinguished.

If the front panel OVERVOLT LED is illuminated, check the generator and/or load conditions. Interrupt input power or shut down the generator for a minimum of 10 seconds.

If the front panel OVERVOLT LED is not illuminated, proceed to Step 8.

*Step 8.* Verify that the front panel OVERTEMP (Overtemperature) LED is extinguished.

If the front panel OVERTEMP LED is illuminated, increase cooling air to the DECS or allow the ambient air to cool. Interrupt input power or shut down the generator for a minimum of 10 seconds.

If the front panel OVERTEMP LED is not illuminated, proceed to Step 9.

*Step 9.* Replace the DECS unit.

If replacing the DECS unit does not correct the malfunction, then the generator is defective. Consult with the generator manufacturer.

### LOW OUTPUT VOLTAGE

*Step 1.* Verify that the Coarse Voltage adjustment is not set too low.

If the Coarse Voltage adjustment is too low, adjust it to a higher range.

If the Coarse Voltage adjustment is not too low, proceed to Step 2.

*Step 2.* Verify that the Fine Voltage adjustment is not set too low.

If the Fine Voltage adjustment is too low, adjust it to a higher range.

If the Fine Voltage adjustment is not too low, proceed to Step 3.

*Step 3.* Replace the DECS unit.

#### HIGH OUTPUT VOLTAGE

*Step 1.* Verify that the Coarse Voltage adjustment is not set too high.

If the Coarse Voltage adjustment is too high, adjust it to a lower range.

If the Coarse Voltage adjustment is not too high, proceed to Step 2.

*Step 2.* Verify that the Fine Voltage adjustment is not set too high.

If the Fine Voltage adjustment is too high, adjust it to a lower range.

If the Fine Voltage adjustment is not too high, proceed to Step 3.

*Step 3.* Replace the DECS unit.

#### GENERATOR DOES NOT RESPOND AS ADJUSTMENTS ARE MADE

*Step 1.* Reset the DECS by interrupting input power or by shutting down the generator for a minimum of 10 seconds. If the generator still does not respond, proceed to Step 2.

*Step 2.* Replace the DECS unit.

#### POOR VOLTAGE REGULATION

*Step 1.* Verify that the case of the DECS is properly grounded.

If the DECS' case is not properly grounded, ground the DECS case by:

- a) Connect dedicated ground wire to 1/4" faston labeled "GND" at rear of case.

If the DECS' case is properly grounded, proceed to Step 2.

*Step 2.* Check for grounded field leads.

If the field leads are grounded, isolate them from ground.

If the field leads are not grounded, proceed to Step 3.

*Step 3.* If used with a PMG, check for grounded PMG leads. If the PMG leads are grounded, isolate them from ground. If the PMG leads are not grounded, proceed to Step 4.

*Step 4.* Replace the DECS unit.

#### GENERATOR OUTPUT UNSTABLE (HUNTING)

*Step 1.* Verify that the genset prime mover governor is operating properly.

*Step 2.* Verify that the sensing and input power leads are connected securely.

If the sensing or input power leads are not connected securely, tighten the connections.

If the sensing or input power leads are connected securely, proceed to Step 3.

*Step 3.* Verify that the Stability Range is set to the proper range. (Refer to Section 4.)

If the Stability Range is not set to the proper range, reset the Stability Range.

If the Stability Range is set to the proper range, proceed to Step 4.

*Step 4.* Verify that the Stability Level is properly set. (Refer to Section 4.)

If the Stability Level is not properly set, reselect the Stability Level.

#### FRONT PANEL UF (Underfrequency) LED IS ILLUMINATED

*Step 1.* Verify that the generator is operating at rated speed.

If the generator is not operating at rated speed, change the speed to the rated speed.

If the generator is operating at the rated speed, proceed to Step 2.

*Step 2.* Verify that the front panel Underfrequency setting is correct.

If the front panel Underfrequency setting is incorrect, reset the transition point.

*Step 3.* Verify that all sensing and power input connections are secure.

If connections are not secure, secure connections.

#### FRONT PANEL OVEREXC (Overexcitation) LED IS ILLUMINATED

*Step 1.* Check for generator overloading.

If generator is operating with a larger than rated load, shed load.

If generator is operating with a rated or less than rated load, proceed to Step 2.

*Step 2.* Replace the DECS unit. If replacing the DECS unit does not correct the malfunction, proceed to Step 3.

*Step 3.* Refer to generator manual. Generator is defective.

#### NO DROOP OR NEGATIVE DROOP (GENERATOR NOT SHARE LOAD)

*Step 1.* Check for open in Droop CT wiring.

If wiring is open, repair wiring as necessary.

If wiring is not open, proceed to Step 2.

*Step 2.* Verify that Droop CT polarity is correct.

If polarity is incorrect, reverse connections at terminals CTB1 and CTB2.

If polarity is not reversed, proceed to Step 3.

*Step 3.* If the above steps fail to correct the malfunction, replace the DECS unit.

#### NO VOLTAGE MATCHING

*Step 1.* Verify Voltage Matching option was purchased and is enabled.

If not enabled, adjust state through front panel switches.

If enabled, proceed to Step 2.

*Step 2.* Verify all connections are correct per Figures 3-10 through 3-13 as required for the Voltage Matching optioned DECS.

If the interconnection is incorrect, reconnect per appropriate interconnect diagram.

If the interconnection is correct, proceed to Step 3.

*Step 3.* Check for correct utility reference voltage on DECS terminals BUS1 and BUS3.

If the interconnection is incorrect, reconnect per appropriate interconnect diagram.

If the interconnection is correct, check for open system fuses.

Verify correct sensing potential transformer, if used, is used on BUS1 and BUS3 leads.

If correct, proceed to Step 4.

*Step 4.* Verify the generator output voltage setpoint is within 20% of measured utility bus voltage.

If setpoint is too low, adjust Coarse Voltage (CV) to the appropriate level.

If setpoint is correct, proceed to Step 5.

*Step 5.* If the above steps fail to correct the Voltage Matching malfunction, replace the DECS.

#### FINE VOLTAGE ADJUST BAND NOT CENTERED AROUND THE COARSE VOLTAGE ADJUST SETTING

*Step 1* Use the **SELECT** button on the front panel to select coarse voltage adjust.

*Step 2* Press and release the **DECREASE** button.

*Step 3* Press and release the **INCREASE** button.

*Step 4* Press and release the **SELECT** button.  
**OR , ALTERNATIVELY, USE THE DCIM:**

*Step 1* Select "Generator Voltage"

*Step 2* Press and release <ENTER>.

*NO COMMUNICATION WITH DCIM UNIT*

Step 1. Verify that the 9V battery is properly connected in the DCIM unit.

Remove the four screws on the front panel of the DCIM unit.

If battery is improperly connected, reconnect the battery.

If battery is properly connected, proceed to Step 2.

Step 2. Replace the 9V battery. If replacing the battery does not correct the malfunction, proceed to Step 3.

Step 3. Replace the DCIM unit.

# SECTION 6 • REPLACEMENT PARTS

---

## GENERAL

The following list (Table 6-1) describes the components and assemblies of the DECS that have maintenance significance. When ordering parts from Basler Electric Company, be sure to specify the DECS Model and Style Number, reference Basler replacement part number, quantity, and description.

*Table 6-1. Replacement Parts*

| <b>Reference</b> | <b>Part Number</b> | <b>Qty.</b> | <b>Description</b>               |
|------------------|--------------------|-------------|----------------------------------|
| --               | 9 2849 00 101      | 1           | DECS Power Module                |
| --               | 9 2653 00 025      | 1           | Settings Label, adhesive-backed. |

# SECTION 7 • MANUAL CHANGE INFORMATION

## CHANGES

Substantive changes in this manual to date are summarized in Table 7-1.

*Table 7-1. Summary of Changes*

| Revision | Summary of Changes   | ECA No. | Date  |
|----------|--|---------|-------|
| F        | Changed Table 1-1 to Figure 1-1 and all corresponding references, tables, and figures. Added UL Recognition and CSA Certification to Table 1-4. Added sentence to Section 3, <i>Voltage Matching Input</i> , to clarify that S3 should be open to disable voltage matching after the generator is paralleled. Corrected Figure 3-11 to add polarity marks to CTs. Added note to Section 4 to clarify that the DCIM unit contains a 9V battery. Added to Section 5, <i>Troubleshooting</i> , "No Communication with the DCIM unit." Added Section 7 • Manual Change Information. Changed the format of the manual. Distinguished front cover of the manual from the DECS software Version 2.0.5 manual. Corrected any minor errors. | 16286   | 10/97 |
| G        | Changed front cover part numbers from "9 2653 00 106 through - 111" to only "9 2653 00 112."   | 16430   | 11/97 |
| H        | Updated Figure 3-6. Corrected Figure 3-7 in Note 3 from "+ or -1 VDC" to "+ or -3 VDC." Added phase rotation information for A-C-B rotation to <i>Paralleling Input</i> . Section 4, Table 4-4 and same table in Section 3, added to note "For versions 2.0.5 or later, it is recommended that Droop Mode is active when VAR/PF is active."  | 16657   | 04/98 |