

INSTRUCTION MANUAL

FOR

GROUND DIRECTIONAL OVERCURRENT RELAY

BE1-67N

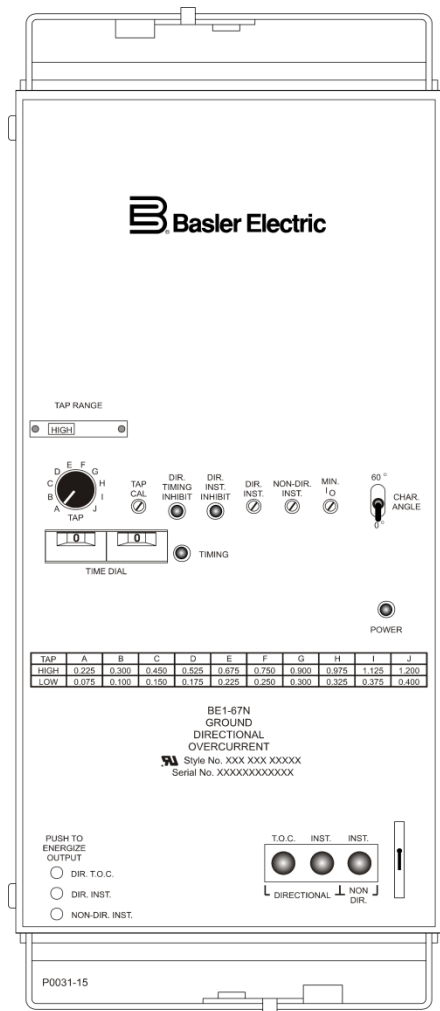

B Basler Electric

Publication: 9190700990
Revision: G 02/13

INTRODUCTION

This instruction manual provides information about the operation and installation of the BE1-67N Ground Directional Overcurrent Relay. To accomplish this, the following information is provided:

- General Information and Specifications
- Controls and Indicators
- Functional Description
- Installation
- Testing

WARNING!

To avoid personal injury or equipment damage, only qualified personnel should perform the procedures in this manual.

NOTE

Be sure that the relay is hard-wired to earth ground with no smaller than 12 AWG copper wire attached to the ground terminal on the rear of the unit case. When the relay is configured in a system with other devices, it is recommended to use a separate lead to the ground bus from each unit.

First Printing: May 1992

Printed in USA

© 2013 Basler Electric, Highland Illinois 62249 USA

All Rights Reserved

February 2013

CONFIDENTIAL INFORMATION

of Basler Electric, Highland Illinois, USA. It is loaned for confidential use, subject to return on request, and with the mutual understanding that it will not be used in any manner detrimental to the interest of Basler Electric.

It is not the intention of this manual to cover all details and variations in equipment, nor does this manual provide data for every possible contingency regarding installation or operation. The availability and design of all features and options are subject to modification without notice. Should further information be required, contact Basler Electric.

**BASLER ELECTRIC
12570 STATE ROUTE 143
HIGHLAND IL 62249 USA**

<http://www.basler.com>, info@basler.com

PHONE +1 618.654.2341

FAX +1 618.654.2351

REVISION HISTORY

The following information provides a historical summary of the changes made to the BE1-67N instruction manual (9190700990). Revisions are listed in reverse chronological order.

Manual Revision and Date	Change
G, 02/13	<ul style="list-style-type: none"> • Updated case and cover drawings in Section 4.
F, 08/07	<ul style="list-style-type: none"> • Moved content of Section 6, <i>Maintenance</i> to Section 4. • Updated power supply burden data in Section 1. • Updated Target Indicator description in Section 3.
E, 01/07	<ul style="list-style-type: none"> • Enhanced the readability of various figures throughout the manual.
D, 10/06	<ul style="list-style-type: none"> • Updated description of Polarizing Source Select Switch (S3) in Table 2-2 of Section 2, <i>Controls and Indicators</i>. • Updated Output Contacts ratings in Section 1, <i>General Information</i>.
C, 10/05	<ul style="list-style-type: none"> • Deleted references to service manual 9190700620. • Removed reference to jumper-selectable Y power supply from style chart. Updated power supply ratings in Section 1. • Corrected instantaneous overcurrent maximum operating times listed in the specifications and Table 3-5. • Corrected the polarizing voltage input burden listed in the specifications. • Removed the shorting bar shown across terminals 5 and 6 in Figures 4-1 and 4-7. • Corrected the current values listed in Table 3-2, <i>Sensing Input Ranges and Settings for 1 Aac Secondary</i>. • Updated all illustrations showing relay front panel or case cover. • Created new Section 5 containing operational test procedures. • Created new Appendix A containing characteristic curves previously contained in Section 1. • Created new Appendix B, <i>Polar Graph Forms</i>. • Updated style/format of the manual.
B, 06/93	<ul style="list-style-type: none"> • Changed all sections of the manual to reflect revised specifications. • Expanded switch and control terminology in Section 2. • Revised Figure 3-1. • In Section 4, included I_o polarization testing and a separate operational test procedure for sensing input ranges 3 and 4.
A, 10/92	<ul style="list-style-type: none"> • Revised Figures 3-1 through 3-3 and added Figure 3-4. • Added Section 6, <i>Manual Change Information</i>.
—, 05/92	<ul style="list-style-type: none"> • Initial release

This page intentionally left blank.

CONTENTS

SECTION 1 • GENERAL INFORMATION	1-1
SECTION 2 • CONTROLS AND INDICATORS.....	2-1
SECTION 3 • FUNCTIONAL DESCRIPTION	3-1
SECTION 4 • INSTALLATION	4-1
SECTION 5 • TESTING	5-1
APPENDIX A • CHARACTERISTIC CURVES	A-1
APPENDIX B • POLAR GRAPH FORMS	B-1

This page intentionally left blank.

SECTION 1 • GENERAL INFORMATION

TABLE OF CONTENTS

SECTION 1 • GENERAL INFORMATION	1-1
PURPOSE	1-1
APPLICATION	1-1
Zero Sequence Current	1-1
Zero Sequence Voltage	1-2
Dual Zero Sequence Current and Voltage	1-2
OUTPUT CONTACTS	1-2
Relay Status Alarm	1-2
Tripping	1-2
Auxiliary	1-3
PUSH-TO-ENERGIZE OUTPUTS	1-3
TARGETS	1-3
POWER SUPPLY OPTIONS	1-3
POWER-UP DELAY	1-3
MODEL AND STYLE NUMBER	1-3
Style Number Example	1-3
SPECIFICATIONS	1-4
Current Sensing (I_o) Inputs	1-4
Frequency	1-4
Polarizing Current (I_o)	1-5
Polarizing Voltage (V_o)	1-5
Directional Unit	1-5
Time Overcurrent	1-5
Instantaneous Overcurrent	1-6
Power Supply	1-6
Output Contacts	1-6
Target Indicator	1-7
Type Tests	1-7
Agency Recognition	1-7
Physical	1-7

Figures

Figure 1-1. Zero Sequence Polarizing (Two-Winding Transformer)	1-1
Figure 1-2. Zero Sequence Polarizing (Three-Winding Transformer)	1-2
Figure 1-3. Style Number Identification Chart	1-4

Tables

Table 1-1. Maximum Operate Times	1-6
Table 1-2. Power Supply Types and Ratings	1-6

This page intentionally left blank.

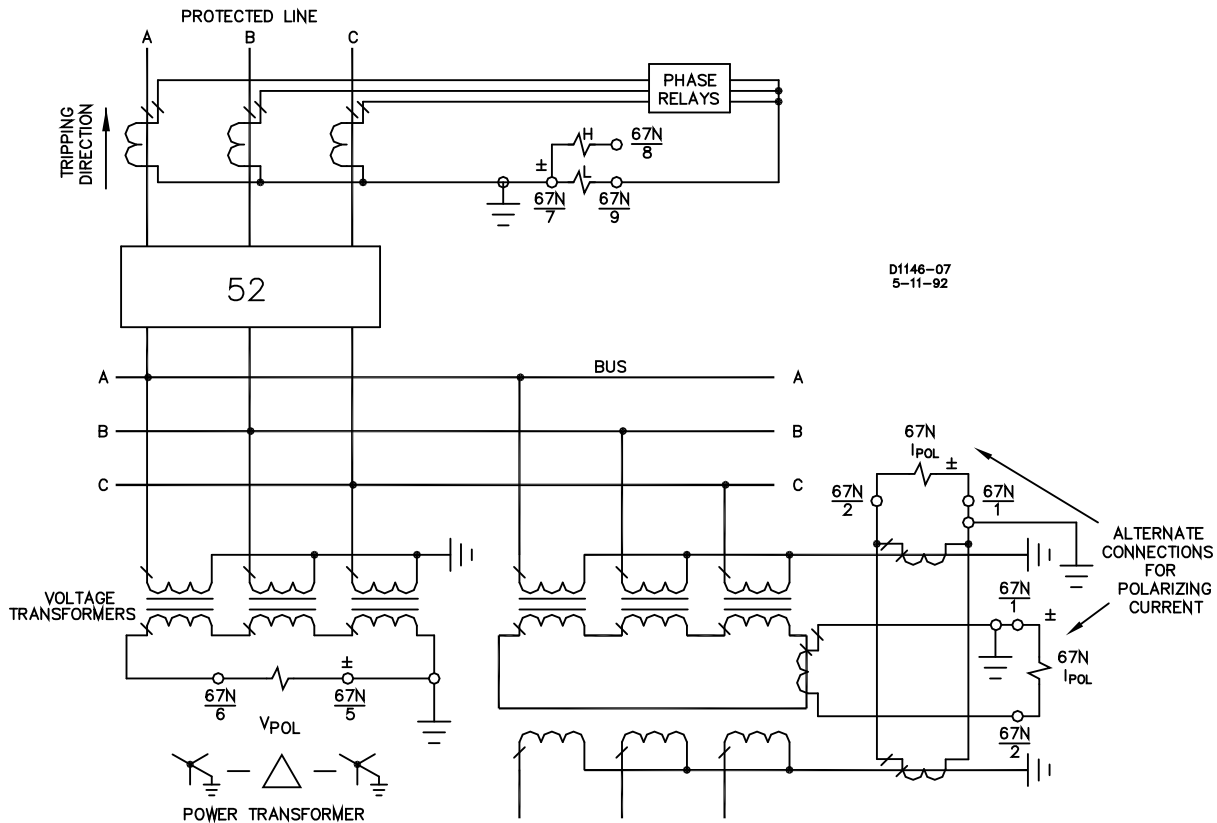

Figure 1-2. Zero Sequence Polarizing (Three-Winding Transformer)

Zero Sequence Voltage

Zero sequence voltage polarization is preferred for higher ground source impedances. Refer to Figures 1-1 and 1-2 for relay connections that obtain zero sequence voltage ($3V_0$) from a set of grounded wye-broken delta voltage transformers. The voltage polarized relay has a directional polarization adjustment to match the impedance angle of the protected line to the characteristic angle of the relay. This is the angle about which the directional angle is centered. A choice of line angles allows the relay to be adjusted to include the resistance component of the ground fault.

Dual Zero Sequence Current and Voltage

Dual polarization is preferred where ground source impedance varies, or to provide redundant polarization. Dual polarization is achieved using a polarizing signal that is the phasor sum of the current and voltage polarizing signals.

OUTPUT CONTACTS

BE1-67N relays have the following output contacts: relay status alarm (relay fail), tripping, and auxiliary (optional).

Relay Status Alarm

A relay status alarm output contact (relay fail) indicates that proper voltages are not being supplied to the internal relay circuitry or that the microprocessor self-diagnostics has detected an error. This alarm output contact is normally closed.

Tripping

Normally open or normally closed tripping contacts are included for each function within the relay. Configuration of these contacts is defined by the relay style number. These output contacts are used with optionally selected target indicator circuits.

Auxiliary

Normally open, normally closed, or single pole double throw (SPDT) auxiliary contact configurations are provided to act in parallel with the tripping function(s) of the relay. Configuration of the auxiliary output contacts are also defined by the relay style chart.

An auxiliary contact can be configured (via internal switches) to operate in parallel with any combination of tripping outputs. Configurable auxiliary outputs permit use of the BE1-67N relay in various carrier schemes.

PUSH-TO-ENERGIZE OUTPUTS

A push-to-energize pushbutton is included for each tripping output contact. These pushbuttons can be used to verify correct operation of external control circuit wiring without the need to supply test signals to the relay. Control power must be applied for this function to operate. The pushbuttons are recessed behind the relay front panel and are not accessible with the cover installed.

TARGETS

One target is included for each tripping function as specified by style number. Targets are operated either by the internal signal initiating tripping (internally operated) or by a minimum of 200 mAac flowing through the series circuit consisting of the target coil and output relay contacts (current operated). Within a specific relay, all targets must be operated in the same way.

POWER SUPPLY OPTIONS

Various power supply options are available to allow the BE1-67N relay to be used with standard supply voltages. See the style chart for details.

POWER-UP DELAY

A power-up delay timer is initiated upon application of control power to the relay to prevent undesired contact transitions when sensing signals are present. Operation of measuring circuits and output circuits are inhibited (less than 0.5 seconds) until the power-up delay period has expired.

MODEL AND STYLE NUMBER

Electrical characteristics and operational features included in a specific relay are defined by a combination of letters and numbers that makes up the style number. Figure 1-3 illustrates the BE1-67N style number identification chart. The style number together with the model number describe the features and options in a particular device and appear on the front panel, draw-out cradle, and inside the case assembly.

Style Number Example

Operating features and characteristics of BE1-67N relays are identified by the style number. For example, a BE1-67N relay with style number **A1E-Z2J-B4C0F** has the following features and options.

- A** zero sequence current, voltage, or dual polarized
- 1** 60 Hz sensing with a range of 0.25 to 6.0 Aac
- E** normally open output contacts
- Z2** switch-selectable timing characteristics
- J** relay operating power derived from 125 Vdc or 120 Vac
- B** current operated targets
- 4** two instantaneous elements: directional and non-directional
- C** push-to-energize outputs (pushbuttons)
- 0** no auxiliary output contacts
- F** semi-flush case mounting

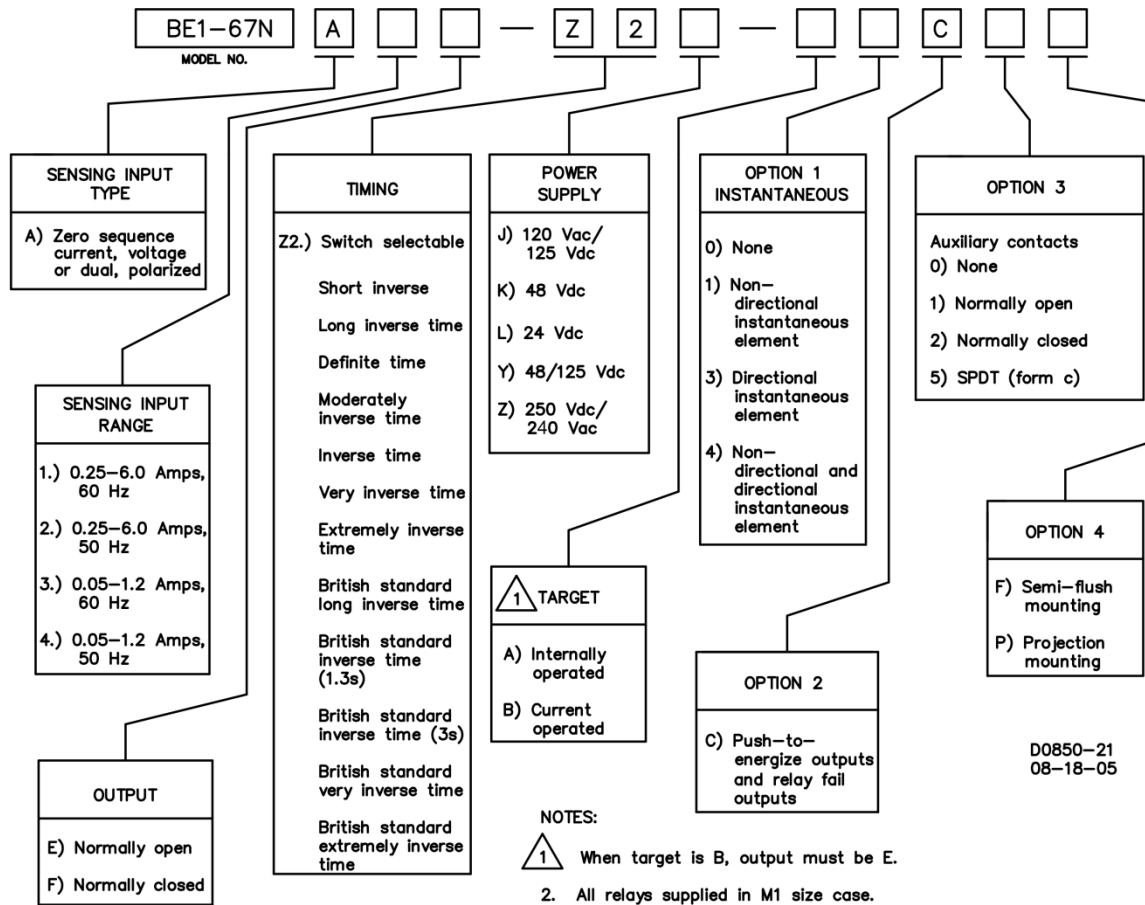

Figure 1-3. Style Number Identification Chart

SPECIFICATIONS

BE1-67N relays have the following features and capabilities.

Current Sensing (I_o) Inputs

Pickup Adjustment Range

Range 1 and 2: 0.25 to 6.0 Aac
Range 3 and 4: 0.05 to 1.2 Aac

Current Rating

Sensing Input Range 1 and 2

Continuous Rating: 7.5 Aac
5 Minute Rating: 20 Aac
1 Second Rating: 150 Aac

Sensing Input Range 3 and 4

Continuous Rating: 1.5 Aac
5 Minute Rating: 4 Aac
1 Second Rating: 30 Aac

Burden

Maximum: <0.1 Ω

Frequency

Nominal

50 Hz or 60 Hz

Range

50 Hz Nominal:	45 to 55 Hz
60 Hz Nominal:	55 to 65 Hz

Polarizing Current (I₀)

Current Rating

Continuous:	10 Aac
1 Second:	150 Aac

Minimum Sensing Level

Directional Instantaneous:	Front-panel adjustable from 0.75 to 2.0 Aac
Time Overcurrent:	Fixed at 0.2 Aac

Burden

Maximum:	<0.1 Ω
----------	---------------

Polarizing Voltage (V₀)

Maximum Rating (Line-to-Neutral)

Continuous:	240 Vac
1 Second:	360 Vac

Minimum Sensing Level

Directional Instantaneous:	4.0 Vac
Time Overcurrent:	0.75 Vac

Burden

At 120 Vac:	<1 VA
-------------	-------

Operating Region

Operating region is $\pm 75^\circ$ (150° window) centered about the characteristic angle.

Harmonic Sensitivity

Polarizing voltage is not affected by third or higher harmonics.

Characteristic Angle

Characteristic angle is switch-selectable to 0 or 60°. Characteristic angle accuracy is $\pm 5^\circ$ for V₀ inputs below 30 Vac and $\pm 10^\circ$ for V₀ inputs greater than 30 Vac.

Directional Closing Band

Directional closing band is $\pm 75^\circ$ centered about the characteristic angle.

Directional Unit

Response Time:	Within 15 ms to change in direction and magnitude
Repeatability:	Set angles are repeatable within $\pm 3\%$ or 1°, whichever is greater

Time Overcurrent

Pickup Range

Sensing Input Range 1 and 2:	0.25 to 6 Aac
Sensing Input Range 3 and 4:	0.05 to 1.2 Aac

Pickup Accuracy

Within $\pm 5\%$ of the expected value established by tap selector switch with the intertap adjustment at its maximum clockwise setting.

Repeatability

Repeatability of pickup setting (combination of tap selector switch and intertap adjustment) is $\pm 2\%$.

Response Time Accuracy

Within $\pm 5\%$ of the time value indicated on the characteristic time curve or 25 ms, whichever is greater.

Operate Time Repeatability

Operate time is repeatable within $\pm 2\%$ or 25 ms, whichever is greater.

Instantaneous Overcurrent

Pickup Range for Directional and Non-Directional Instantaneous Elements

Sensing Input Range 1 and 2: 2 to 100 Aac
Sensing Input Range 3 and 4: 0.4 to 20 Aac

Maximum Operate Time

Maximum operating times are derived while stepping from a steady state (normal conditions) to an overcurrent condition. When stepping from an inhibit state, the maximum times are longer. Table 1-1 lists the instantaneous operate times for multiples of pickup.

Table 1-1. Maximum Operate Times

Multiple of Pickup	Operate Time
1.05 Aac	100 ms
2.0 Aac	35 ms
5.0 Aac	20 ms

Pickup Accuracy: Within $\pm 5\%$ of the defined pickup setting
Repeatability: $\pm 5\%$
Response Time: Within 25 ms to a current reversal after fault inception

Power Supply

Relay operating power may be obtained from a wide variety of external sources. When ordering, any one of five internal power supply types may be selected to match the operating power voltage level available at your site. Available power supply types are listed in Table 1-2.

Table 1-2. Power Supply Types and Ratings

Type	Input Voltage		Burden at Nominal
	Nominal	Range	
J (mid range)	125 Vdc 120 Vac	24 to 150 Vdc 90 to 132 Vac	2.9 W 12.8 VA
K (mid range)	48 Vdc	24 to 150 Vdc	2.7 W
L (low range)	24 Vdc	12 to 32 Vdc *	2.8 W
Y (mid range)	48 Vdc 125 Vdc	24 to 150 Vdc 24 to 150 Vdc	2.7 W 2.9 W
Z (high range)	250 Vdc 240 Vac	68 to 280 Vdc 90 to 270 Vac	3.1 W 22.0 VA

* Type L power supply may require 14 Vdc to begin operation. Once operating, the voltage may be reduced to 12 Vdc.

Output Contacts

Resistive Ratings

120 Vac: Make, break, and carry 7 Aac continuously
250 Vdc: Make and carry 30 Adc for 0.2 s, carry 7 Adc continuously, and break 0.3 Adc
500 Vdc: Make and carry 15 Adc for 0.2 s, carry 7 Adc continuously, and break 0.3 Adc

Inductive Ratings

120 Vac, 125 Vdc, 250 Vdc: Break 0.3 A (L/R = 0.04)

Target Indicator

A choice of either internally operated targets or current operated targets is available as specified by style number. Internally operated targets use the internal trip signal to energize the output relay and target drivers. Current operated targets are energized by a minimum of 0.2 A flowing through the output contacts.

Type Tests

Dielectric Strength

Withstands 1,500 Vac at 60 Hz for 1 minute in accordance with IEC 255-5 and ANSI/IEEE C37.90.1-1989

Surge Withstand Capability

Qualified to C37.90.1-1989 and IEC 255-5

Radio Frequency Interference

Field-tested using a 5 W, handheld transceiver operating at random frequencies centered around 144 MHz and 440 MHz, with the antenna located 6 inches (150 mm) from the relay in both horizontal and vertical planes.

Shock

Withstands 15 G in each of three mutually perpendicular planes without structural damage or degradation of performance.

Vibration

Withstands 2 G in each of three mutually perpendicular planes, swept over the range of 10 to 500 Hz for a total of 6 sweeps, 15 minutes each sweep, without structural damage or degradation of performance.

Agency Recognition

UL

UL recognized per standard 508, UL file number E97033.

GOST-R

GOST-R certified the relevant standards of Gosstandart of Russia.

Physical

Temperature

Operating: -40 to 70°C (-40 to 158°F)

Storage: -65 to 90°C (-85 to 194°F)

Dimensions

See Section 4, *Installation*.

Weight

Maximum: 18 lb (8.2 kg)

This page intentionally left blank.

SECTION 2 • CONTROLS AND INDICATORS

TABLE OF CONTENTS

SECTION 2 • CONTROLS AND INDICATORS	2-1
INTRODUCTION.....	2-1
FRONT PANEL CONTROLS AND INDICATORS.....	2-1
ANALOG AND DIGITAL CIRCUIT BOARD CONTROLS.....	2-3
MOTHER CIRCUIT BOARD CONTROLS.....	2-4

Figures

Figure 2-1. Front Panel Controls and Indicators	2-1
Figure 2-2. Analog and Digital Circuit Board Controls.....	2-3
Figure 2-3. Auxiliary Relay Select Switch Location	2-4

Tables

Table 2-1. Front Panel Controls and Indicators.....	2-2
Table 2-2. Analog and Digital Circuit Board Controls.....	2-3
Table 2-3. Auxiliary Relay Select Switch Selections	2-4

This page intentionally left blank.

SECTION 2 • CONTROLS AND INDICATORS

INTRODUCTION

BE1-67N controls and indicators are located on the front panel and Analog, Digital, and Mother circuit board assemblies.

FRONT PANEL CONTROLS AND INDICATORS

Front panel HMI components are illustrated in Figure 2-1 and described in Table 2-1. The locators and descriptions of Table 2-1 correspond to the locators shown in Figure 2-1.

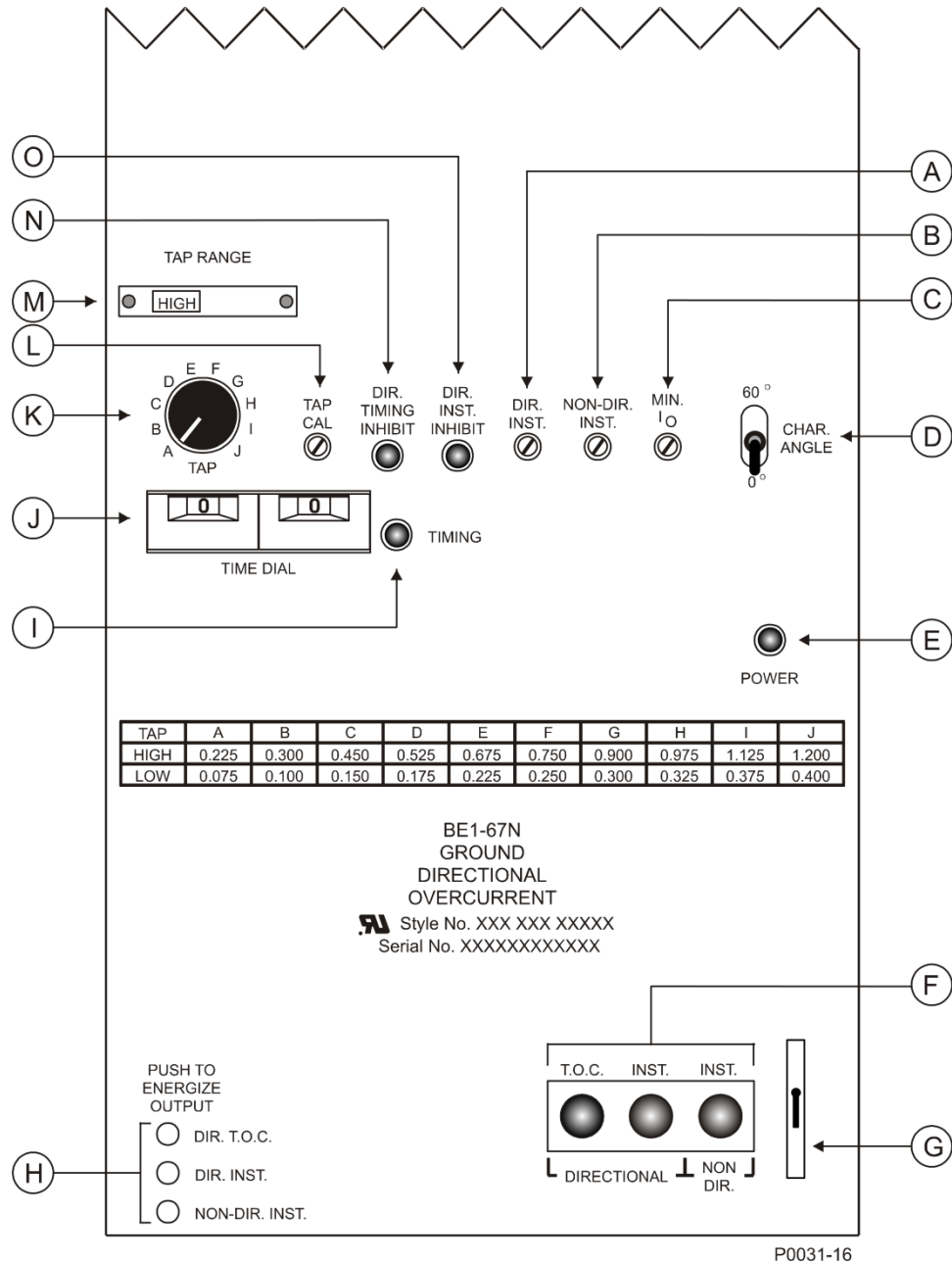

Figure 2-1. Front Panel Controls and Indicators

Table 2-1. Front Panel Controls and Indicators

Locator	Description
A	<i>Directional, Instantaneous Overcurrent Control.</i> Screwdriver adjustment of the directional, instantaneous overcurrent element is made with this multi-turn potentiometer.
B	<i>Non-Directional, Instantaneous Overcurrent Control.</i> Screwdriver adjustment of the non-directional, instantaneous overcurrent element is made with this multi-turn potentiometer
C	<i>Minimum Zero-Sequence Overcurrent Control.</i> Screwdriver adjustment of the zero-sequence current (I_0) level applied to the directional, instantaneous overcurrent element is made with this multi-turn potentiometer.
D	<i>Characteristic Angle Switch.</i> This two-position switch sets the characteristic angle (0° or 60°) for the zero-sequence voltage polarizing unit. With the switch in the 60° position, characteristic angle accuracy is $\pm 5^\circ$ for V_0 inputs below 30 volts and $\pm 10^\circ$ for V_0 inputs greater than 30 volts.
E	<i>Power Indicator.</i> This red LED lights when operating power is applied to relay terminals 3 and 4.
F	<i>Target Indicators.</i> These electronically latching red indicators display the protective element that caused a trip.
G	<i>Target Reset Switch.</i> Operating this switch resets all of the latched target indicators.
H	<i>Push-to-Energize Output Switches.</i> These switches enable testing of the relay output contacts without having to apply current or voltage to the relay sensing inputs. One switch is provided for each output contact. The recessed switches are operated by inserting a nonconductive rod through the front panel switch holes.
I	<i>Timing Indicator.</i> This red LED lights when the time overcurrent setpoint is exceeded and the directional condition is met.
J	<i>Time Dial.</i> These two thumbwheel switches set the time delay for the time-current characteristic shape.
K	<i>Tap Selector.</i> This ten-position rotary switch sets the pickup level for the time overcurrent function. The setting for the time overcurrent function is the value defined by the tap selector switch position. The pickup level for each tap selector switch position is listed in a tap range chart on the front panel.
L	<i>Tap Calibration Control.</i> Screwdriver adjustment of the time overcurrent pickup level is made with this multi-turn potentiometer.
M	<i>Tap Range Plate.</i> This plate is user-adjustable to indicate the setting range (either high or low) that corresponds to the external current sensing connections at terminals 7 and 8 (high) or 7 and 9 (low). The front panel tap range chart lists the values of current that correspond to the high- or low-range current sensing connections and the Tap Selector switch position.
N	<i>Directional Timing Inhibit Indicator.</i> This amber LED lights when operation of the directional time overcurrent element is inhibited by the directional unit.
O	<i>Directional Instantaneous Inhibit Indicator.</i> This amber LED lights when operation of the directional instantaneous overcurrent element is inhibited by the directional unit.

ANALOG AND DIGITAL CIRCUIT BOARD CONTROLS

Front panel HMI components are illustrated in Figure 2-2 and described in Table 2-2. The locators and descriptions of Table 2-2 correspond to the locators shown in Figure 2-2.

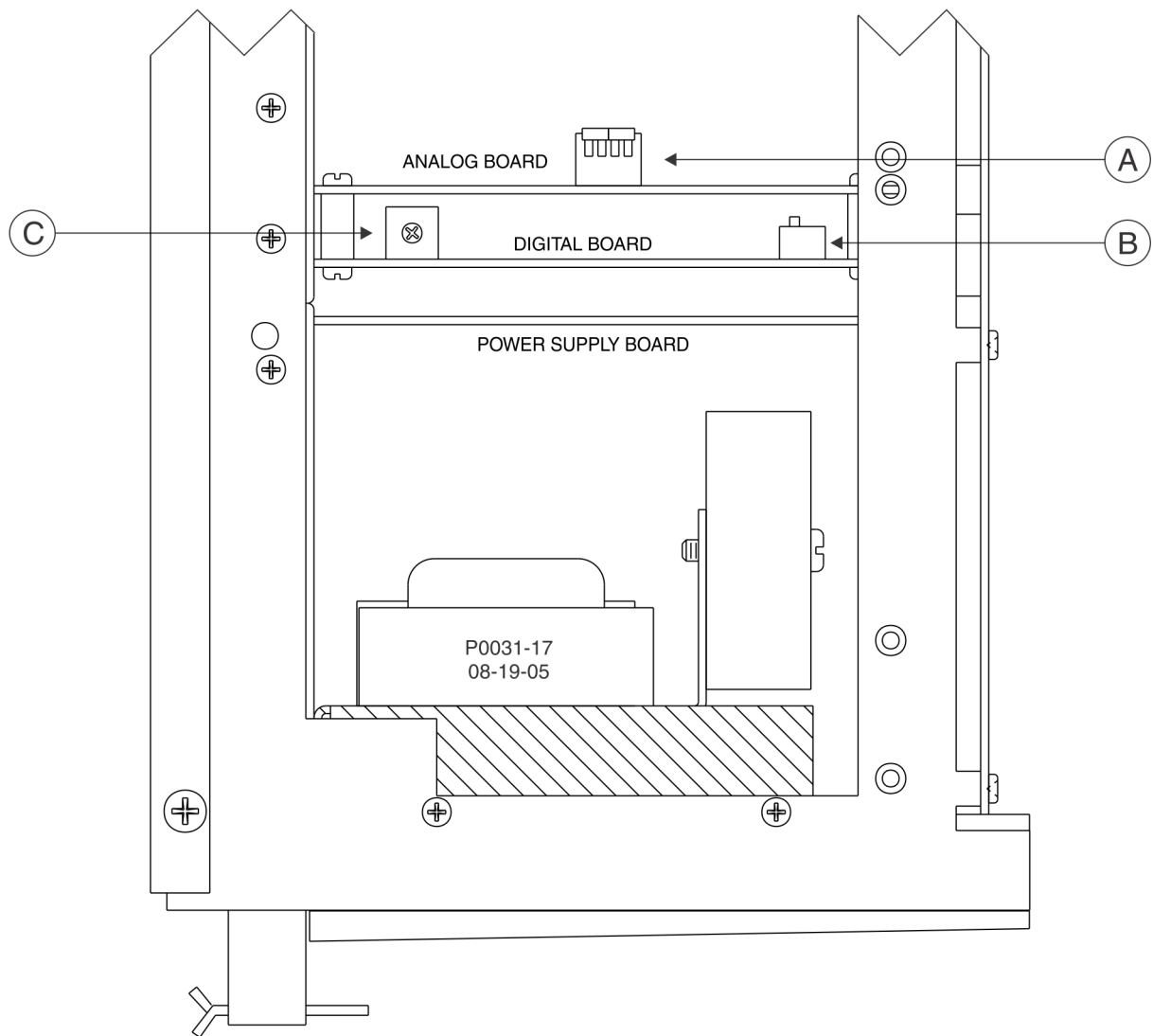

Figure 2-2. Analog and Digital Circuit Board Controls

Table 2-2. Analog and Digital Circuit Board Controls

Locator	Description
A	<i>Polarizing Source Select Switch (S3).</i> This assembly located on the Analog circuit board, consists of two switches. The left-hand switch enables zero-sequence voltage polarization and the right-hand switch enables zero-sequence current polarization. The up position of the switch (as shown) selects the function.
B	<i>Normal/Test Switch (S1).</i> This switch is used only during factory calibration and should remain in the Normal position.
C	<i>Time Overcurrent Characteristic Curve Selector Switch (S6).</i> This switch selects the characteristic curve to be used for the application. See Appendix A, <i>Characteristic Curves</i> for the curves available.

MOTHER CIRCUIT BOARD CONTROLS

Mother circuit board controls consist of a single Auxiliary Relay Select Switch (S1). The location of S1 is illustrated in Figure 2-3.

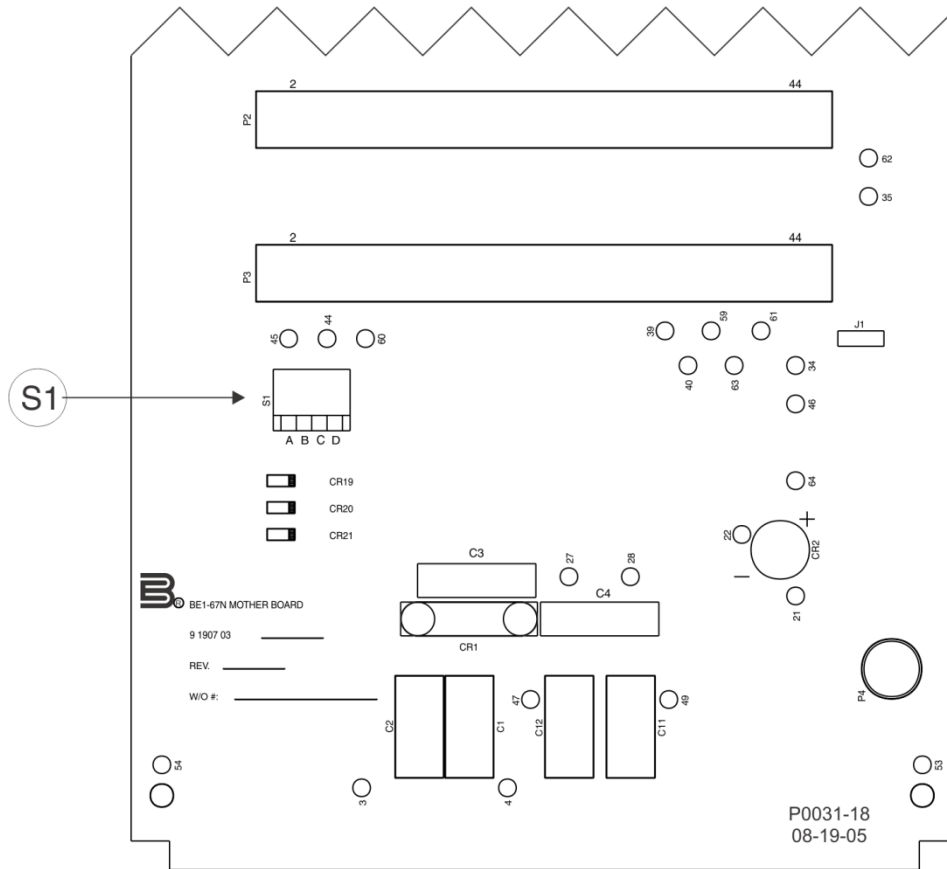

Figure 2-3. Auxiliary Relay Select Switch Location

S1 enables the auxiliary output contact (if equipped) to operate in parallel with any combination of tripping outputs. Table 2-3 lists each tripping output and the S1 position that causes the auxiliary output contact to operate in parallel with it.

Table 2-3. Auxiliary Relay Select Switch Selections

S1 Position	Tripping Output
S1-A	Directional Instantaneous
S1-B	Time Overcurrent
S1-C	Non-Directional Instantaneous
S1-D	Not Used

SECTION 3 • FUNCTIONAL DESCRIPTION

TABLE OF CONTENTS

SECTION 3 • FUNCTIONAL DESCRIPTION	3-1
INTRODUCTION	3-1
CURRENT SENSING	3-1
VOLTAGE SENSING	3-2
DIRECTIONAL ELEMENT	3-2
Zero Sequence Current Polarization	3-2
Zero Sequence Voltage Polarization	3-3
Dual Zero Sequence Current and Voltage Polarization	3-4
OVERCURRENT ELEMENTS	3-4
Time Overcurrent Element	3-4
Instantaneous Overcurrent Elements	3-5
Operate Time	3-5
OUTPUT CONTACTS	3-5
Relay Failure Output Contact	3-5
Tripping Output Contacts	3-5
Auxiliary Output Contacts	3-5
PUSH-TO-ENERGIZE OUTPUT SWITCHES	3-6
POWER SUPPLY	3-6
TARGETS	3-6
Internally Operated Targets	3-6
Current Operated Targets	3-6

Figures

Figure 3-1. Function Block Diagram	3-1
Figure 3-2. Zero Sequence Current Polarizing Phase Relationship	3-3
Figure 3-3. Zero Sequence Voltage Polarizing Phase Relationship (0° Characteristic Angle)	3-3
Figure 3-4. Zero Sequence Voltage Polarizing Phase Relationship (60° Characteristic Angle)	3-4

Tables

Table 3-1. I_{op} Current Sensing Input Connections	3-1
Table 3-2. Sensing Input Range and Setting for 1 Aac Secondary	3-2
Table 3-3. Sensing Input Range and Setting for 5 Aac Secondary	3-2
Table 3-4. Selection Considerations for Characteristic Curves	3-4
Table 3-5. Instantaneous Overcurrent Element Operating Times	3-5

This page intentionally left blank.

SECTION 3 • FUNCTIONAL DESCRIPTION

INTRODUCTION

BE1-67N circuit functions are illustrated in the function block diagram of Figure 3-1 and described in the following paragraphs.

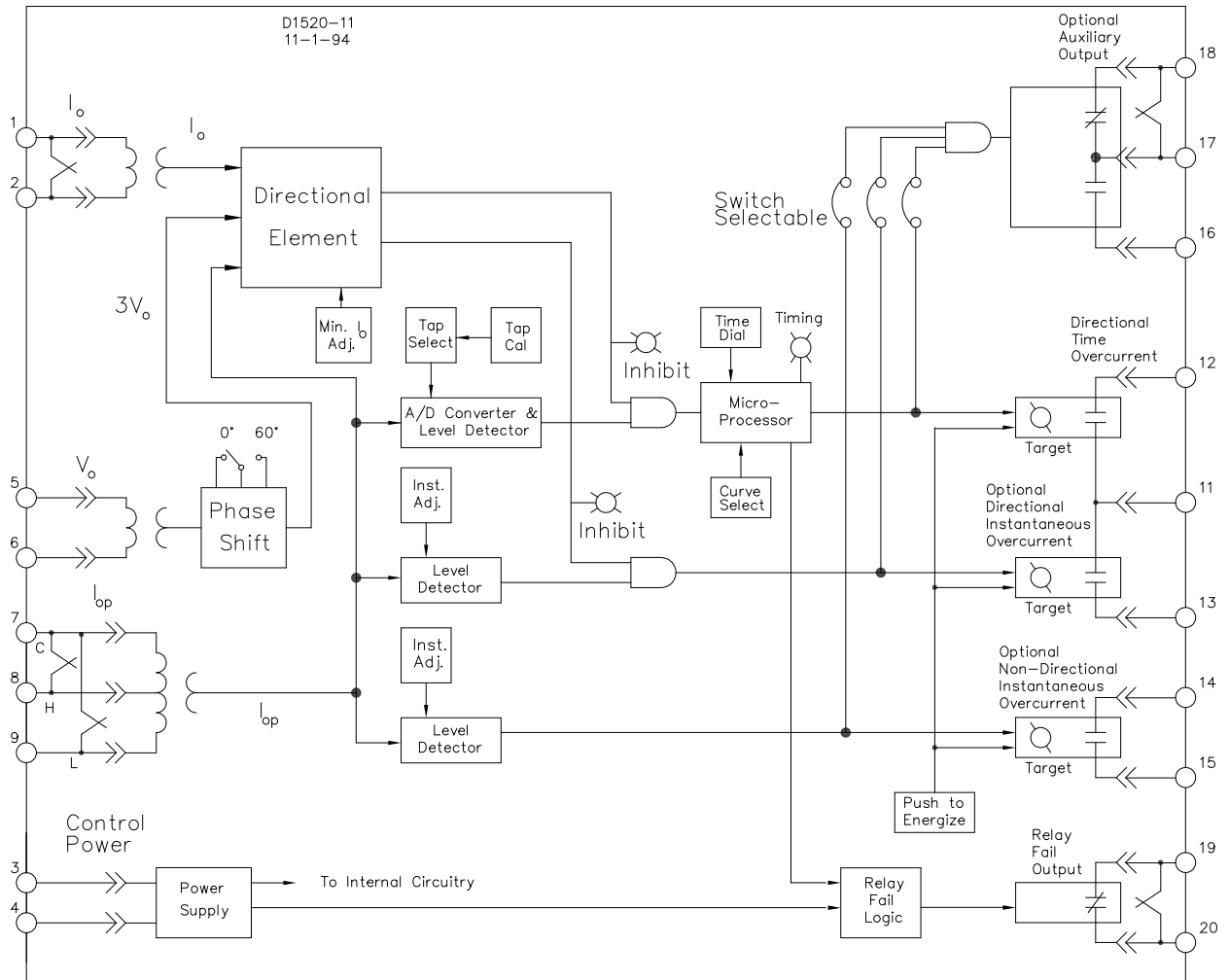

Figure 3-1. Function Block Diagram

CURRENT SENSING

Internal current sensing transformers receive inputs from the 5 Aac (sensing input range 1 or 2) or 1 Aac (sensing input range 3 or 4) nominal secondary of standard transformers. Input transformers for the sensed measured current (I_{op}) are tapped so that the relay range is determined by its external connections. External connections are listed in Table 3-1.

Table 3-1. I_{op} Current Sensing Input Connections

Range		Terminals
1 Aac Nominal	High	0.225 to 1.20 Aac
	Low	0.075 to 0.40 Aac
5 Aac Nominal	High	1.125 to 6.0 Aac
	Low	0.375 to 2.0 Aac

Outputs from the sensing input transformers are applied to a scaling circuit that converts each of the input currents to a dc voltage level. Scaling is controlled by the Tap Selector switch and the Tap Calibration control on the front panel.

The Tap Selector switch is a 10-position rotary switch that controls the relay settings listed in Tables 3-2 and 3-3. The values of current listed are obtained with the Tap Calibration control adjusted fully clockwise. Range is determined by the relay current sensing input connections. When the Tap Calibration control is in the fully clockwise position, the relay pickup setting will be within $\pm 5\%$ of the Tap Selector switch setting.

Table 3-2. Sensing Input Range and Setting for 1 Aac Secondary

Nominal Range	Tap Selector Switch Position										I_{op} Terminals
	A	B	C	D	E	F	G	H	I	J	
High	0.225	0.300	0.450	0.453	0.675	0.750	0.900	0.925	1.125	1.200	7 and 8
Low	0.075	0.100	0.150	0.175	0.225	0.250	0.300	0.325	0.375	0.400	7 and 9

Table 3-3. Sensing Input Range and Setting for 5 Aac Secondary

Nominal Range	Tap Selector Switch Position										I_{op} Terminals
	A	B	C	D	E	F	G	H	I	J	
High	1.125	1.500	2.250	2.625	3.375	3.750	4.500	4.875	5.625	6.000	7 and 8
Low	0.375	0.500	0.750	0.875	1.125	1.250	1.500	1.625	1.875	2.000	7 and 9

The Tap Calibration control provides continuous adjustment between a selected setting of the Tap Selector switch and the next lower setting. When the Tap Calibration control is adjusted fully clockwise, the relay pickup setting will be within $\pm 5\%$ of the Tap Selector switch setting.

VOLTAGE SENSING

The relay receives a polarized voltage input (V_o) from the secondary windings of standard potential transformers or coupling capacitor potential devices. These components supply up to 240 volts (line to neutral) for a 50/60 hertz nominal system frequency.

DIRECTIONAL ELEMENT

The directional element determines when the monitored power system quantities have the proper phase relationship for tripping. The BE1-67N has three types of switch-selectable, directional capabilities: zero sequence current polarization, zero sequence voltage polarization, and dual zero sequence current and voltage polarization. Polarizing Source Select Switch S3, located on the Analog circuit board, is used to select the desired directional capability.

Zero Sequence Current Polarization

The zero sequence current polarizing unit is capable of detecting the phase relationship between the zero sequence current (I_o) and the sensed, measured current (I_{op}) for the relay. This unit is insensitive to third and higher harmonics.

An enabling output from the zero sequence current unit is given when the phase angle between I_o and I_{op} is 75° or less as shown in Figure 3-2. The total trip region (shaded area in Figures 3-2, 3-3, and 3-4) is 150° .

To allow operation of the time overcurrent element, the level of I_o applied to the directional element must be in excess of 0.2 amperes.

To allow operation of the directional instantaneous overcurrent element, the level of I_o applied to the directional element must be in excess of an internal, user adjustable threshold. The range of this setting is 0.75 to 2 amperes. The default, factory setting is 2 amperes.

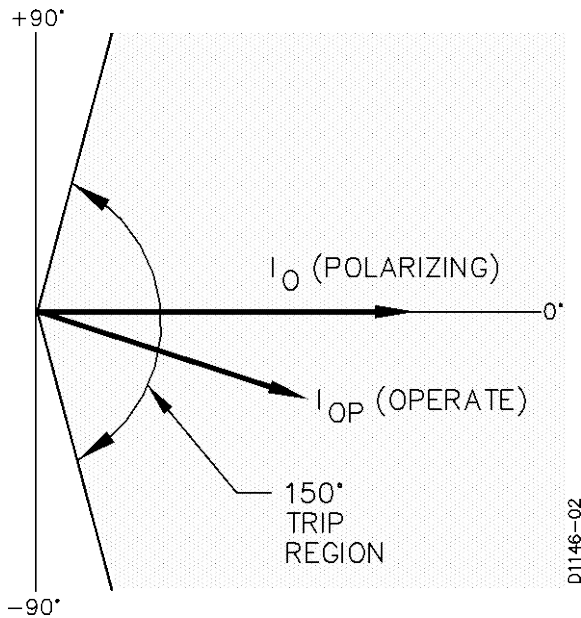

Figure 3-2. Zero Sequence Current Polarizing Phase Relationship

Zero Sequence Voltage Polarization

Zero sequence voltage polarization determines the phase relationship between the zero sequence voltage (V_0) and the sensed, measured current (I_{op}). Third and higher harmonics have no effect on the relay.

Zero sequence voltage element outputs require a minimum voltage level of $V_0 = 0.75$ volts applied to the relay. To enable the directional, instantaneous overcurrent element, the level of V_0 applied to the relay must be 4 volts or more.

Figure 3-3 shows the phase relationship between the sensed measured current (I_{op}) and the zero sequence voltage (V_0).

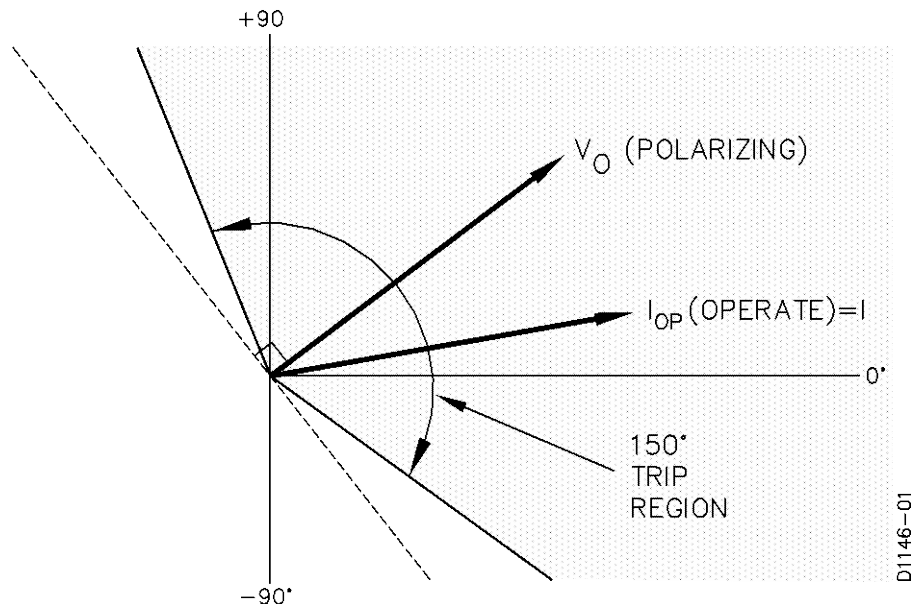

Figure 3-3. Zero Sequence Voltage Polarizing Phase Relationship (0° Characteristic Angle)

The characteristic angle is front-panel selectable for a line impedance angle of 0° or 60° . This is the angle between V_0 and the directional characteristic. The closing band is centered on the directional characteristic (V_0 in Figure 3-3 and shifted 60° in Figure 3-4).

Style Designation	Characteristic Shape	Special Characteristics
B3	Definite Time	Fixed time delay according to time dial setting. Useful for sequential tripping schemes.
B4, E4	Moderately Inverse	Accommodates moderate load changes, as may occur on parallel lines where one line may occasionally have to carry both loads.
B5, E5	Inverse	Provide additional variations of the inverse characteristic, allowing flexibility in meeting load variations, or in coordinating with other relays.
B6, E6	Very Inverse	
B7, E7	Extremely Inverse	

Instantaneous Overcurrent Elements

BE1-67N relays may be optionally equipped with one or two instantaneous elements (one supervised by the directional element). Instantaneous units are supplied from a separately obtained input signal to permit a setting that is independent of the time overcurrent unit. Maximum operating times for the instantaneous overcurrent element are listed in Table 3-5.

Table 3-5. Instantaneous Overcurrent Element Operating Times

Multiples of Pickup	Operate Time
1.05 Aac	100 ms
2.0 Aac	35 ms
5.0 Aac	20 ms

OUTPUT CONTACTS

BE1-67N relays are equipped with a relay failure output contact and tripping output contacts. Auxiliary output contacts are available as an option.

Relay Failure Output Contact

The relay failure output (terminals 19 and 20) is a normally-closed contact that is energized open during normal operating conditions. The output contact closes when the relay power supply is not receiving proper operating voltage and when the microprocessor self-diagnostics function has detected an error. A case-mounted shorting bar places a short-circuit across terminals 19 and 20 when the relay draw-out assembly is removed from the case.

Tripping Output Contacts

Normally open (output option E) or normally closed (output option F) tripping contacts are included for each protective function. The configuration of these contacts is defined by the relay style number.

The directional time trip output contacts are provided at relay terminals 11 and 12.

If the relay is equipped with a non-directional instantaneous element (instantaneous option 1 or 4), non-directional instantaneous trip output contacts are provided at relay terminals 14 and 15. If the relay is equipped with a directional instantaneous element (instantaneous option 3 or 4), directional instantaneous trip output contacts are provided at terminals 11 and 13. Note that the directional time trip output contacts and directional instantaneous trip output contacts share terminal 11 as a common terminal.

Auxiliary Output Contacts

Normally open (auxiliary contacts option 1), normally closed (auxiliary option 2), or single-pole, double-throw (auxiliary option 5) auxiliary output contacts are available and act in tandem with the relay tripping functions.

Auxiliary Relay Select Switch S1, located on the Mother circuit board, can be adjusted to make the auxiliary output contacts operate in tandem with any combination of tripping outputs. The ability to

configure the functionality of the auxiliary output contacts enables the BE1-67N to be used in various carrier schemes. Information about setting S1 is provided in Section 2, *Controls and Indicators*.

PUSH-TO-ENERGIZE OUTPUT SWITCHES

A pushbutton (one for each tripping function) energizes the corresponding output relay for testing purposes. To prevent accidental operation of these switches, they are recessed behind the front panel and are accessed by inserting a thin, non-conducting rod through access holes in the panel. Control power must be applied to energize the output relays but application of sensing voltage and current is not necessary.

POWER SUPPLY

Operating power for the relay circuitry is supplied by a wide range, electrically isolated, low-burden power supply. Power supply operating power is not polarity sensitive. The front panel power LED and power supply status output indicate when the power supply is operating. Power supply specifications are listed in Table 1-2.

TARGETS

Target indicators are optional components selected when a relay is ordered. The electronically latched and reset targets consist of red LED indicators located on the relay front panel. A latched target is reset by operating the target reset switch on the front panel. If relay operating power is lost, any illuminated (latched) targets are extinguished. When relay operating power is restored, the previously latched targets are restored to their latched state.

A relay can be equipped with either internally operated targets or current operated targets.

Internally Operated Targets

Outputs from the overcurrent elements are directly applied to drive the appropriate target indicator. Each indicator is illuminated regardless of the current level in the trip circuit.

Current Operated Targets

A current operated target is triggered by closure of the corresponding output contact and the presence of at least 200 milliamperes of current flowing in the trip circuit.

Note that the front panel function targets (**TIMED**, **INST 1**, etc.) may be either internally or current operated.

NOTE

Prior to August 2007, BE1-67N target indicators consisted of magnetically latched, disc indicators. These mechanically latched target indicators have been replaced by the electronically latched LED targets in use today.

SECTION 4 • INSTALLATION

TABLE OF CONTENTS

SECTION 4 • INSTALLATION	4-1
INTRODUCTION.....	4-1
RELAY OPERATING GUIDELINES AND PRECAUTIONS	4-1
MOUNTING.....	4-1
CONNECTIONS.....	4-9
MAINTENANCE	4-12
STORAGE.....	4-12

Figures

Figure 4-1. Panel Cutting/Drilling, Semi-Flush, M1 Case.....	4-2
Figure 4-2. M1 Case Dimensions, Rear View, Double Ended, Semi-Flush Mount.....	4-3
Figure 4-3. M1 Case Dimensions, Side View, Double Ended, Semi-Flush Mount	4-4
Figure 4-4. Panel Cutting/Drilling, Double Ended, Projection Mount Case	4-5
Figure 4-5. M1 Case Dimensions, Rear View, Double Ended, Projection Mount	4-6
Figure 4-6. M1 Case Dimensions, Side View, Double Ended, Projection Mount.....	4-7
Figure 4-7. M1 Case Cover Dimensions, Front View	4-8
Figure 4-8. Typical Internal Connections.....	4-10
Figure 4-9. Typical Sensing Input Connections (Two Winding Transformer).....	4-11
Figure 4-10. Typical Sensing Input Connections (Three Winding Transformer).....	4-11
Figure 4-11. Typical Output Connections.....	4-12

This page intentionally left blank.

SECTION 4 • INSTALLATION

INTRODUCTION

BE1-67N relays are shipped in sturdy cartons to prevent damage during transit. Upon receipt of a relay, check the model and style number against the requisition and packing list to see that they agree. Inspect the relay for shipping damage. If there is evidence of damage, file a claim with the carrier, and notify your sales representative or Basler Electric.

If the relay will not be installed immediately, store it in its original shipping carton in a moisture- and dust-free environment. Before placing the relay in service, it is recommended that the test procedures of Section 5, *Testing* be performed.

RELAY OPERATING GUIDELINES AND PRECAUTIONS

Before installing or operating the relay, note the following guidelines and precautions.

- For proper current operated target operation, a minimum current of 200 milliamperes must flow through the output trip circuit.
- If a wiring insulation test is required, remove the connection plugs and withdraw the relay from its case.

CAUTION

When the connection plugs are removed, the relay is disconnected from the operating circuit and will not provide system protection. Always be sure that external operating (monitored) conditions are stable before removing a relay for inspection, test, or service.

NOTE

Be sure that the relay is hard-wired to earth ground with no smaller than 12 AWG copper wire attached to the ground terminal on the rear of the case. When the relay is configured in a system with other devices, it is recommended to use a separate lead to the ground bus from each device.

MOUNTING

Because the relay is of solid-state design, it does not have to be mounted vertically. Any convenient mounting angle may be chosen. Relay outline dimensions and panel drilling diagrams are illustrated in Figures 4-1 through 4-7.

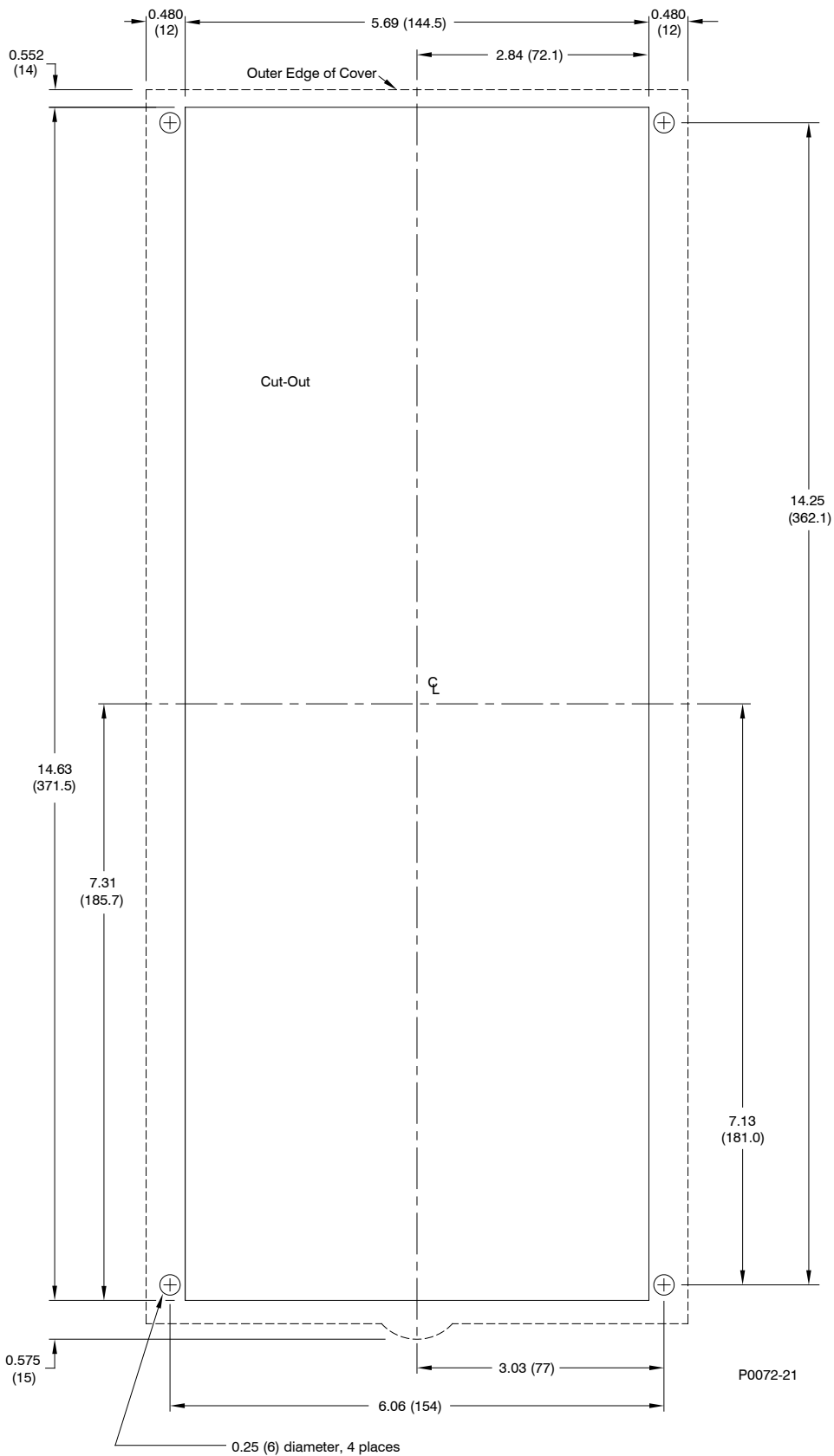

Figure 4-1. Panel Cutting/Drilling, Semi-Flush, M1 Case

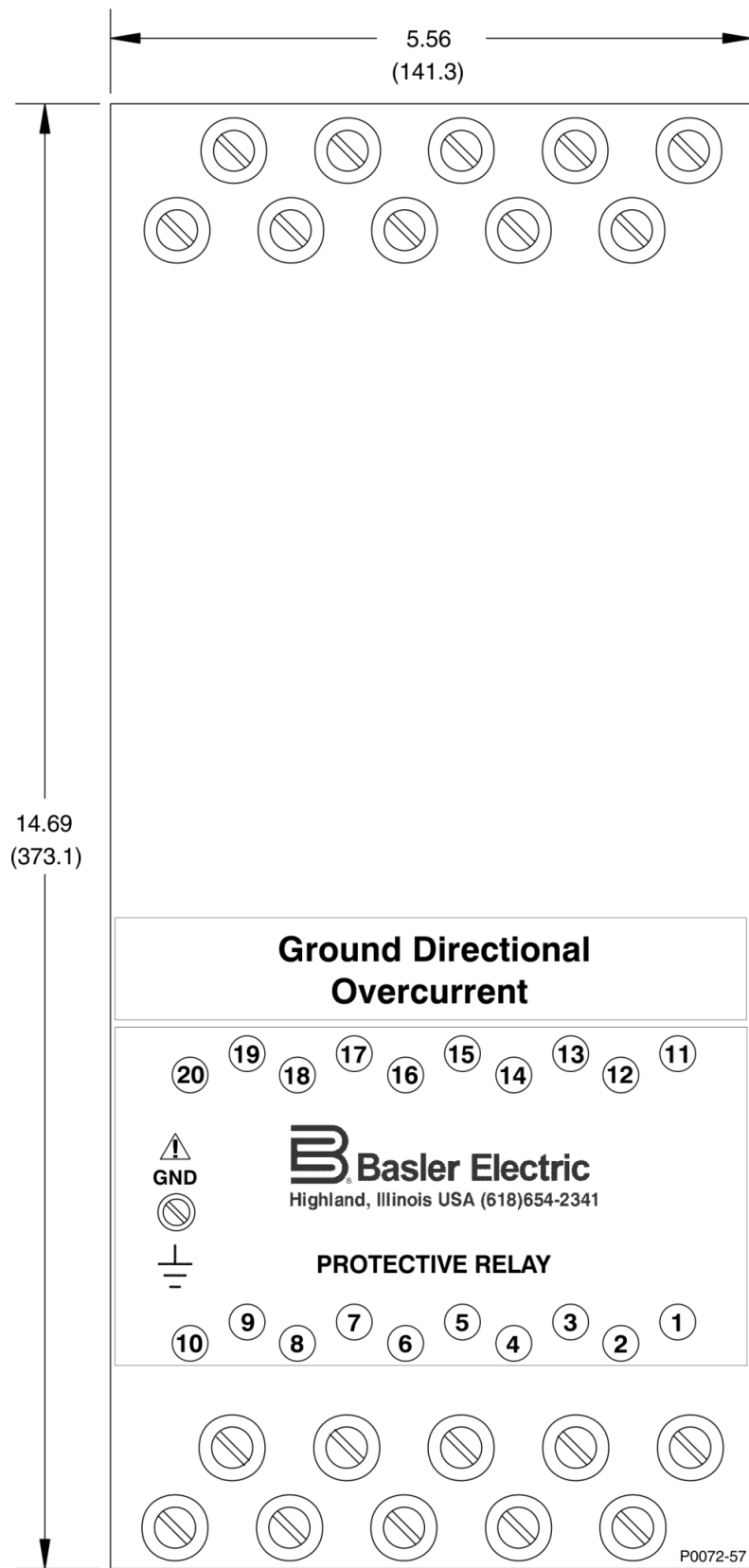

Figure 4-2. M1 Case Dimensions, Rear View, Double Ended, Semi-Flush Mount

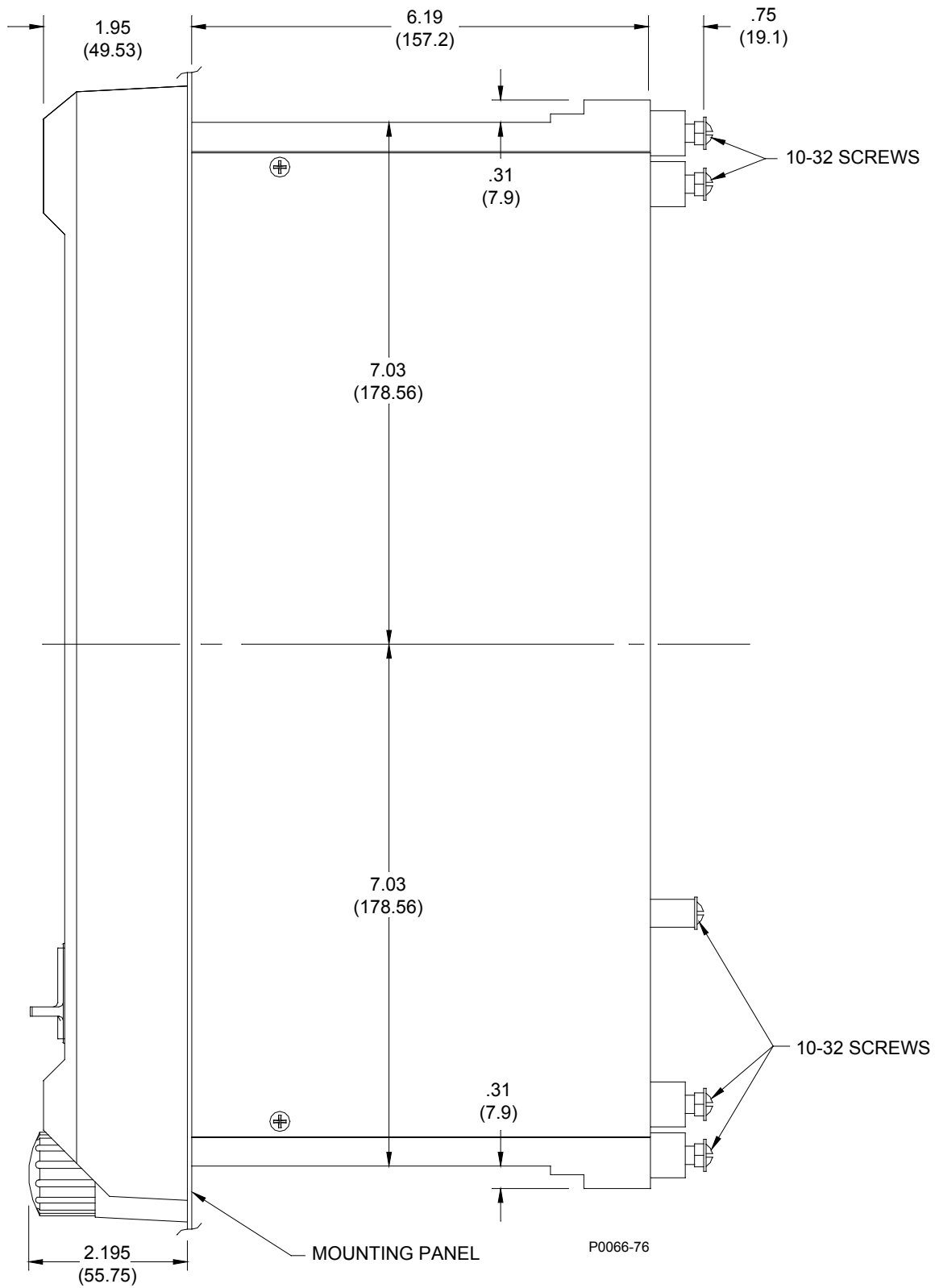

Figure 4-3. M1 Case Dimensions, Side View, Double Ended, Semi-Flush Mount

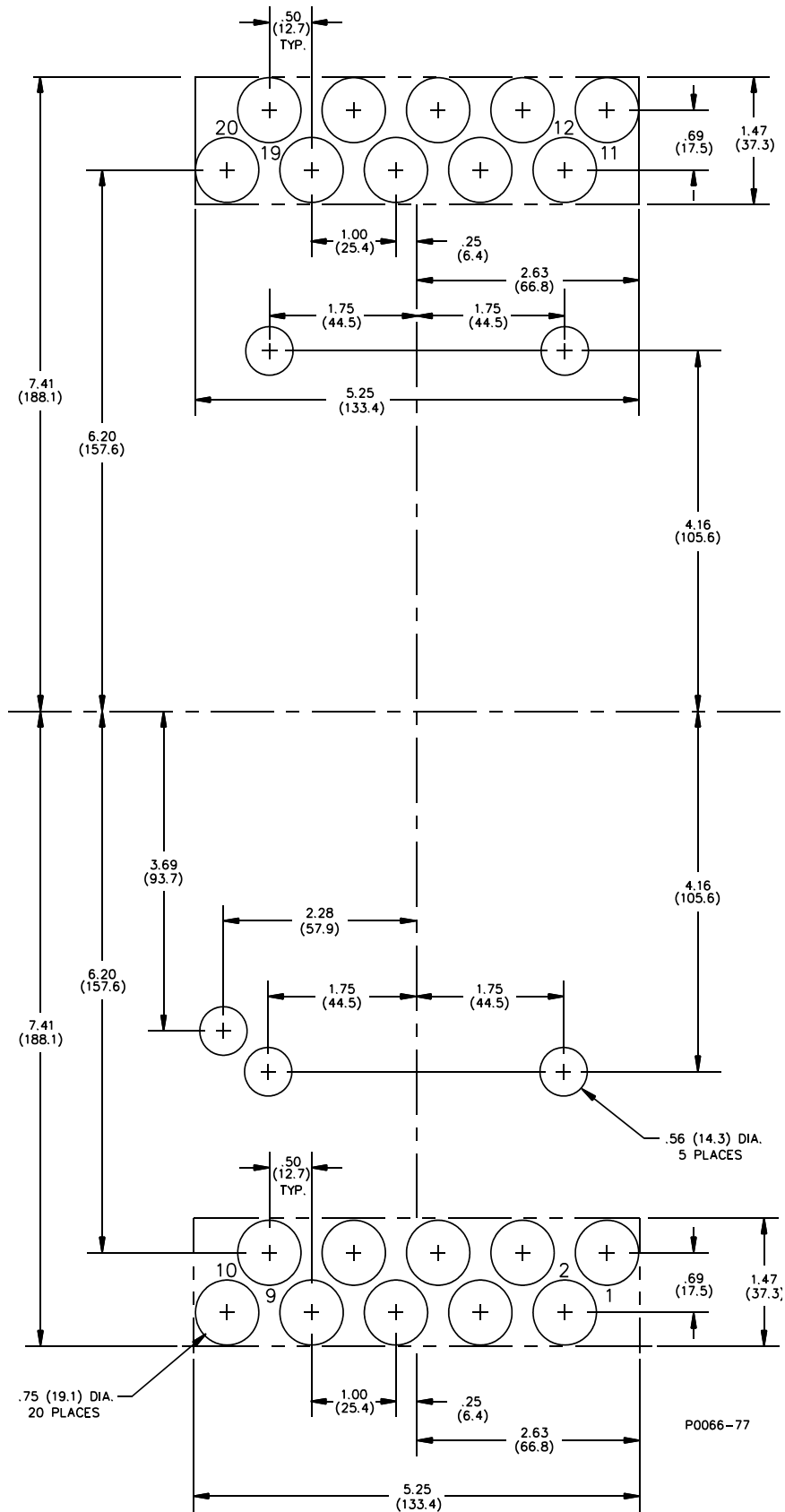

Figure 4-4. Panel Cutting/Drilling, Double Ended, Projection Mount Case

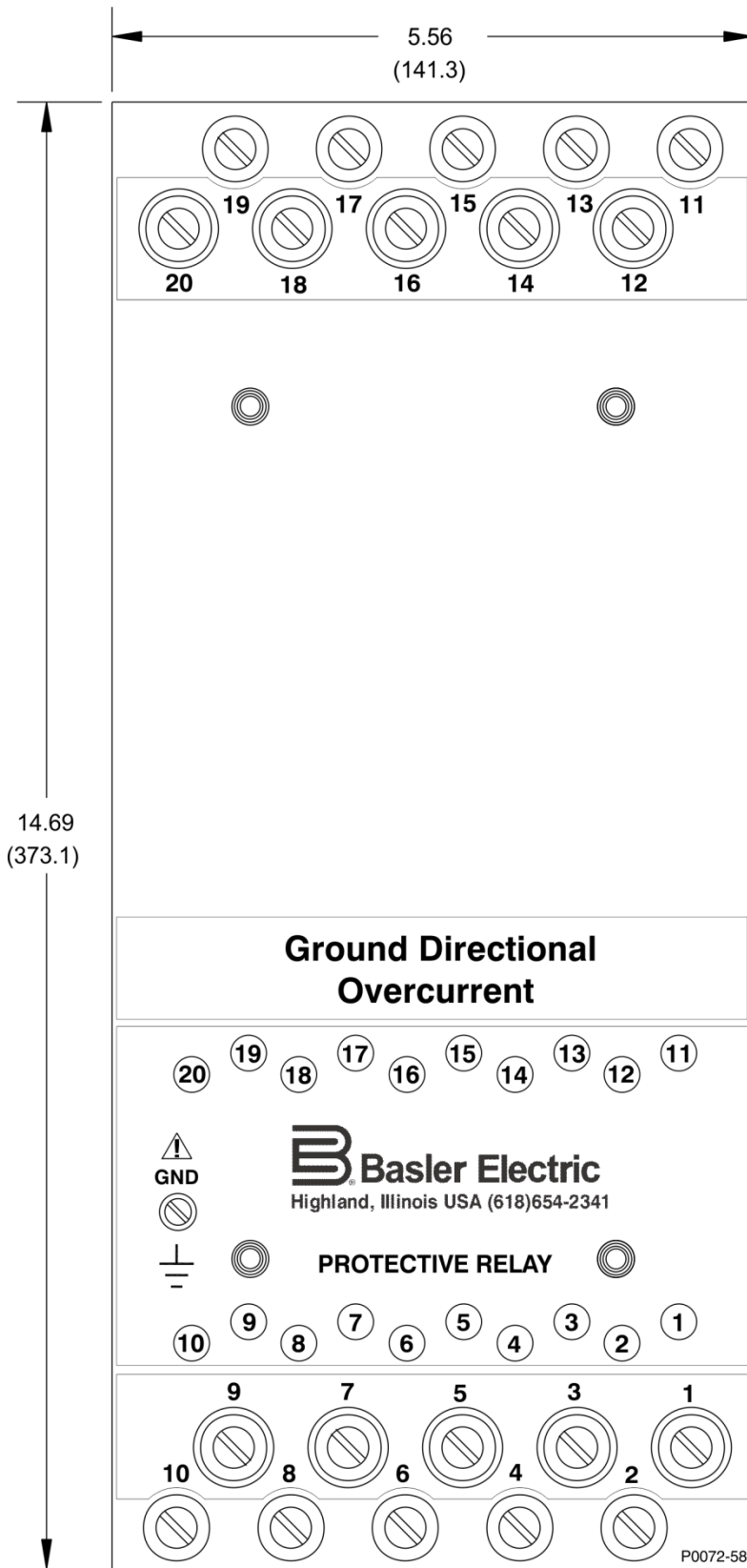

Figure 4-5. M1 Case Dimensions, Rear View, Double Ended, Projection Mount

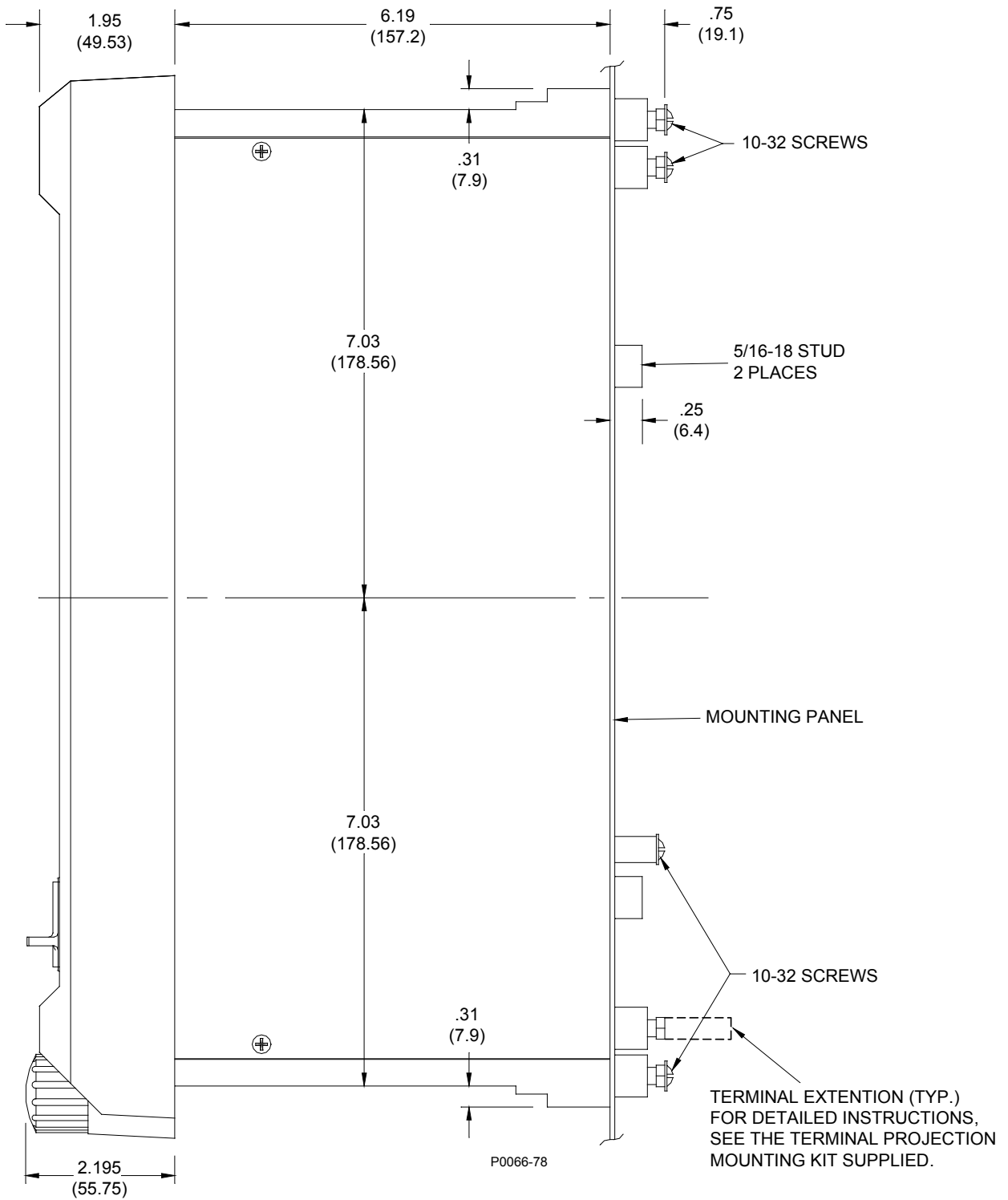

Figure 4-6. M1 Case Dimensions, Side View, Double Ended, Projection Mount

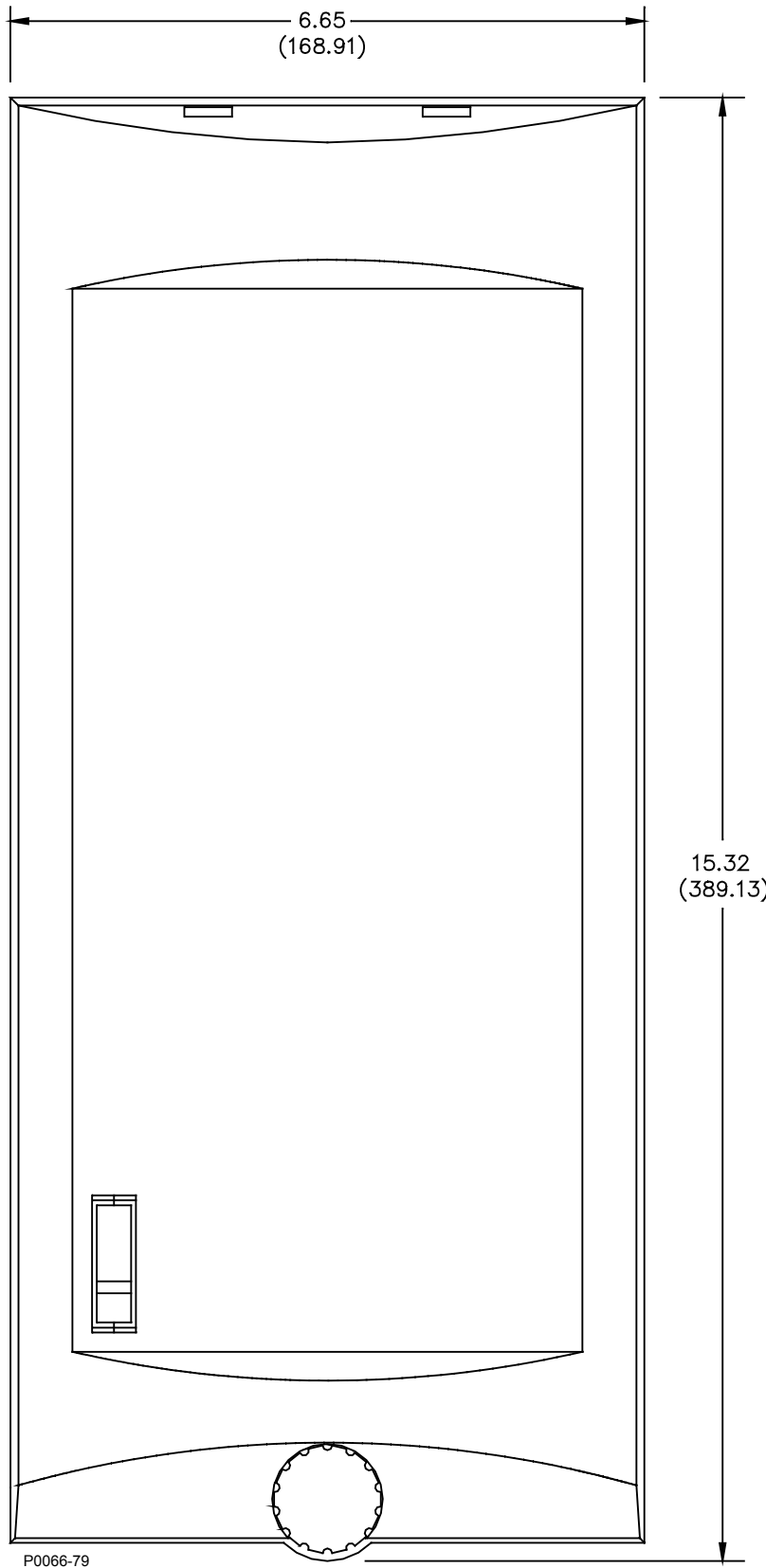
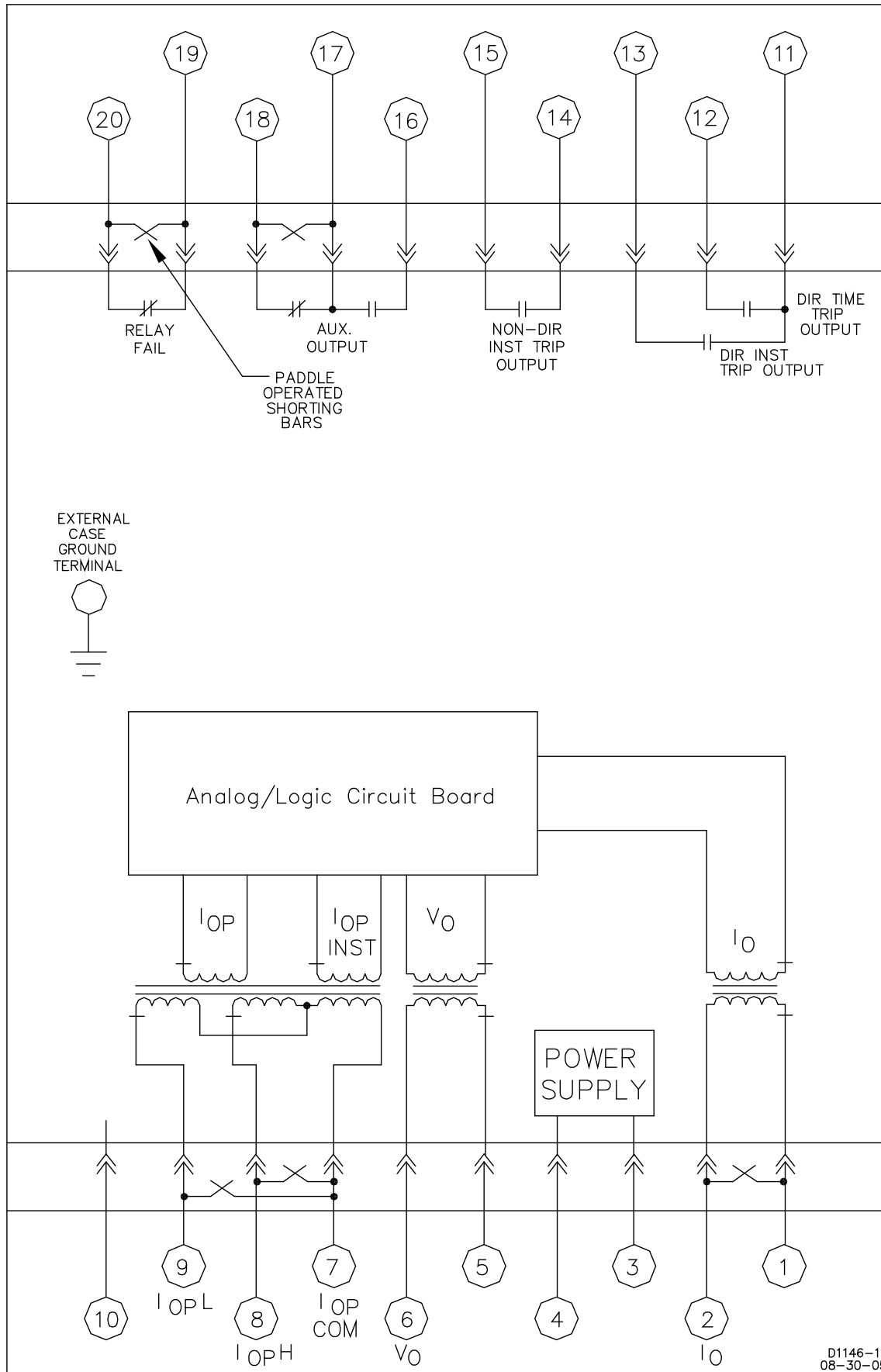

Figure 4-7. M1 Case Cover Dimensions, Front View

CONNECTIONS

Be sure to check the model and style number of a relay before connecting and energizing the relay. Incorrect wiring may result in damage to the relay. Except where noted, connections should be made with wire no smaller than 14 AWG.

Internal relay connections are shown in Figure 4-8. Typical sensing input connections are shown in Figures 4-9 and 4-10. Typical output connections are shown in Figure 4-11.



D1146-11
08-30-05

Figure 4-8. Typical Internal Connections

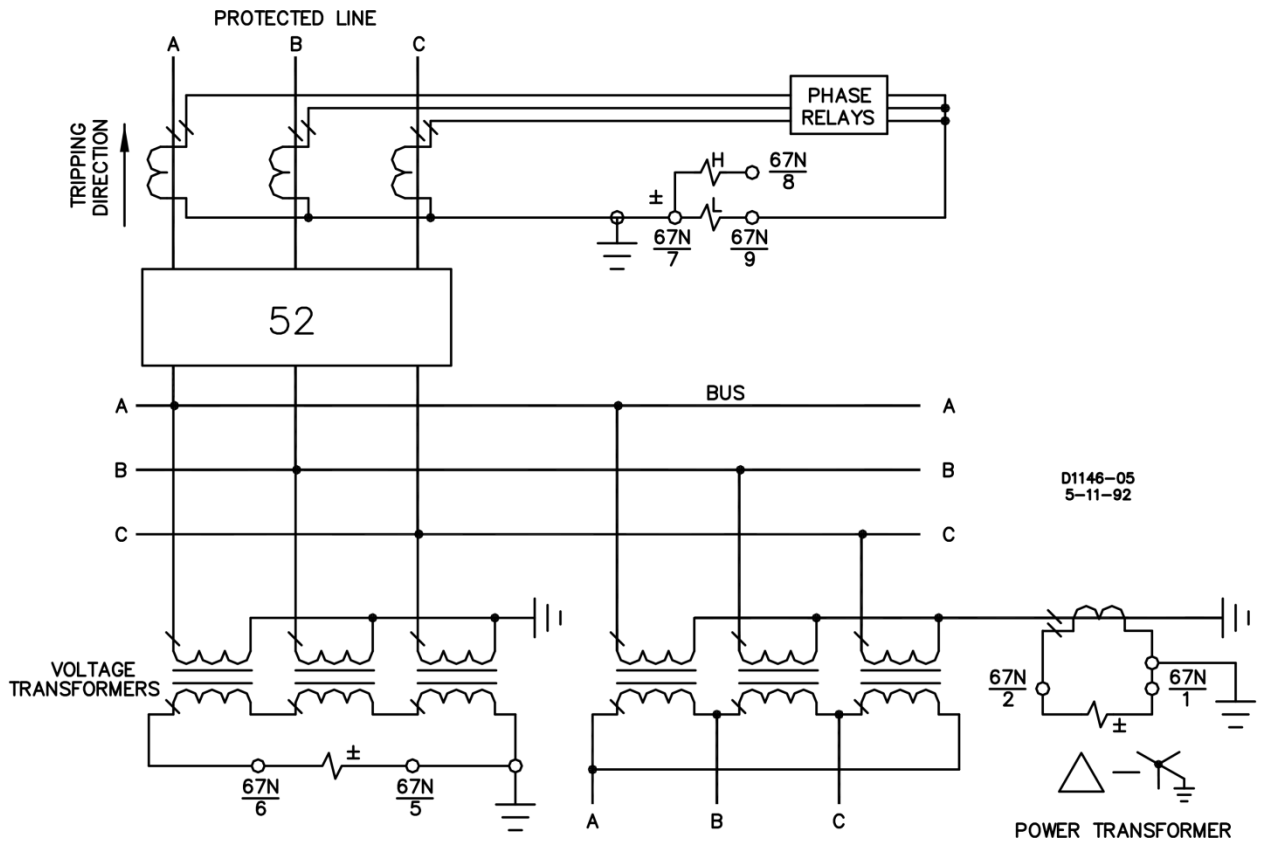

Figure 4-9. Typical Sensing Input Connections (Two Winding Transformer)

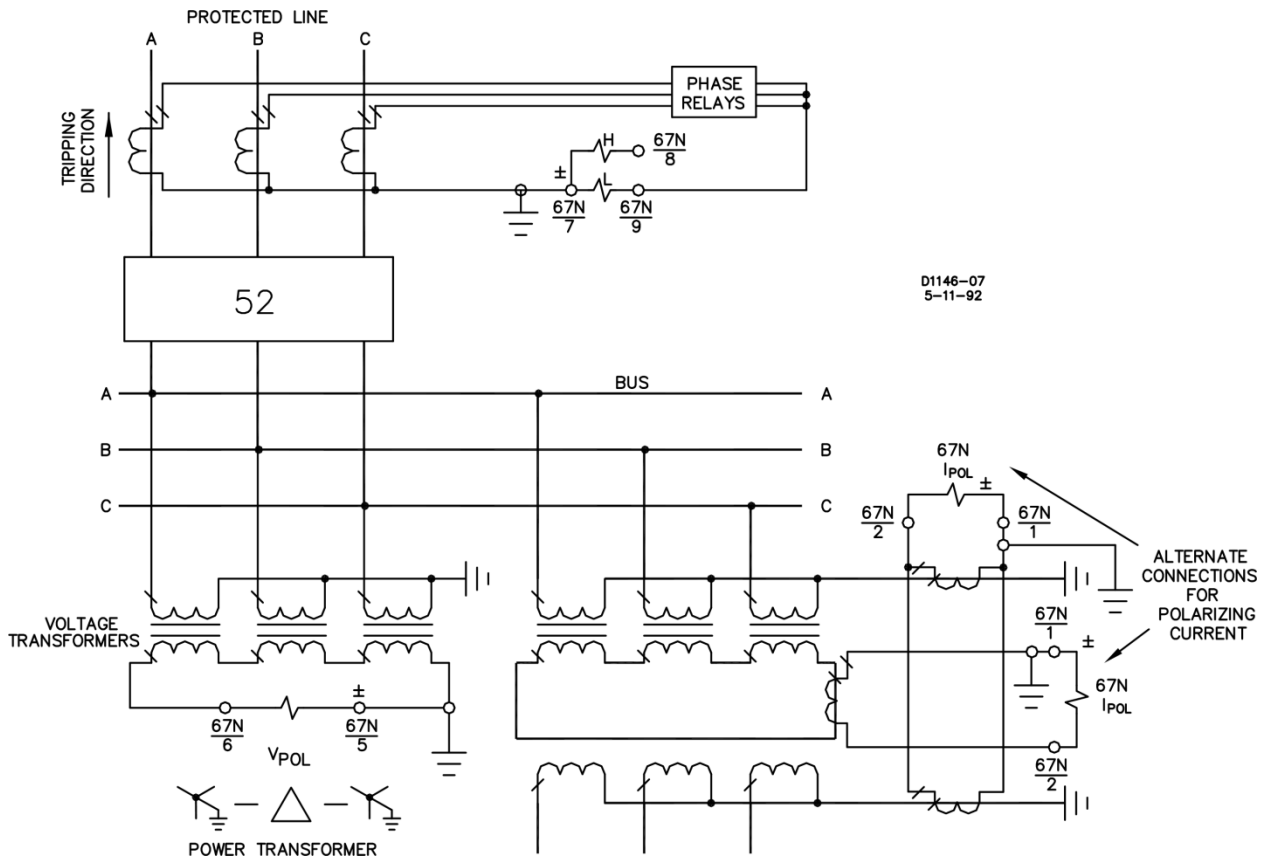

Figure 4-10. Typical Sensing Input Connections (Three Winding Transformer)

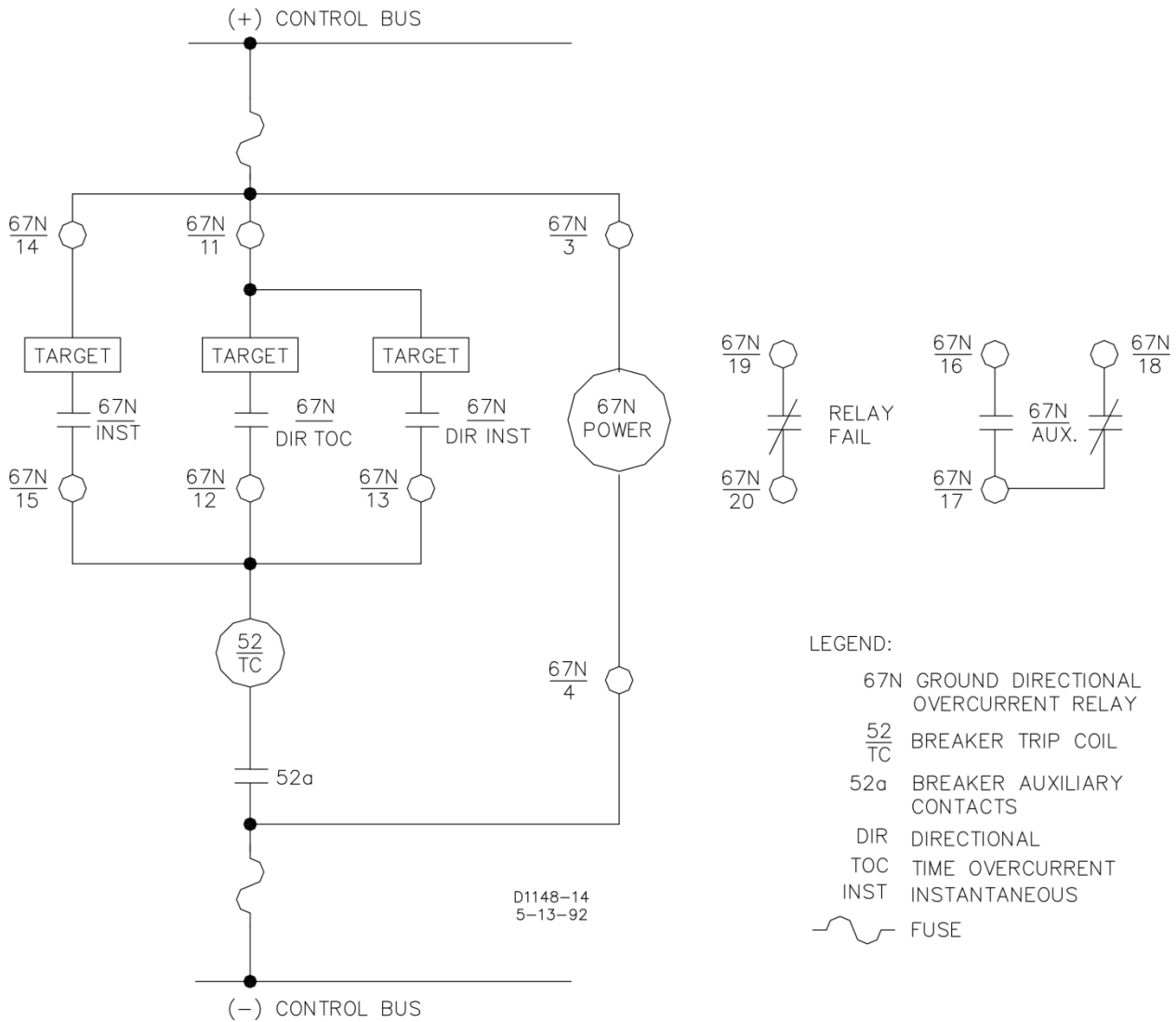

Figure 4-11. Typical Output Connections

MAINTENANCE

BE1-67N relays require no preventative maintenance other than a periodic operational check. If the relay fails to function properly, contact Technical Sales Support at Basler Electric to coordinate repairs.

STORAGE

This device contains long-life aluminum electrolytic capacitors. For devices that are not in service (spares in storage), the life of these capacitors can be maximized by energizing the device for 30 minutes once per year.

SECTION 5 • TESTING

TABLE OF CONTENTS

SECTION 5 • TESTING	5-1
INTRODUCTION.....	5-1
TEST PROCEDURES FOR SENSING INPUT RANGES 1 AND 2.....	5-1
Operational Test Procedure	5-1
Timing Curve Verification	5-5
TEST PROCEDURES FOR SENSING INPUT RANGES 3 AND 4.....	5-6
Operational Test Procedure	5-6
Timing Curve Verification	5-8

Figures

Figure 5-1. Typical Test Connections.....	5-1
Figure 5-2. Trip Zone Using V_o as Polarizing Source (Char. Angle = 0°)	5-3
Figure 5-3. Trip Zone Using V_o as Polarizing Source (Char. Angle = 60°)	5-4
Figure 5-4. Trip Zone Using IO as Polarizing Source (Char. Angle = 0°)	5-5

Tables

Table 5-1. Pickup Values for Tap Selector Positions – Input Ranges 1 and 2	5-2
Table 5-2. Expected Timing at Five Times Pickup.....	5-5
Table 5-3 Pickup Values for Tap Selector Positions – Input Ranges 3 and 4	5-7

This page intentionally left blank.

SECTION 5 • TESTING

INTRODUCTION

This section provides procedures for testing the operation of BE1-67N relays. Separate test procedures are provided for relays with sensing input ranges 1 and 2 and sensing input ranges 3 and 4. Use the procedures that correspond to the sensing input range of your relay.

TEST PROCEDURES FOR SENSING INPUT RANGES 1 AND 2

The following paragraphs contain procedures for verifying the operation and timing curves of a BE1-67N relay with sensing input range 1 or 2.

Operational Test Procedure

Following a preliminary test setup, BE1-67N operational testing consists of a time overcurrent pickup test, an instantaneous overcurrent pickup test (directional and non-directional), V_o directional verification, and I_o directional verification.

Preliminary Test Setup

1. Connect the BE1-67N relay as shown in Figure 5-1.

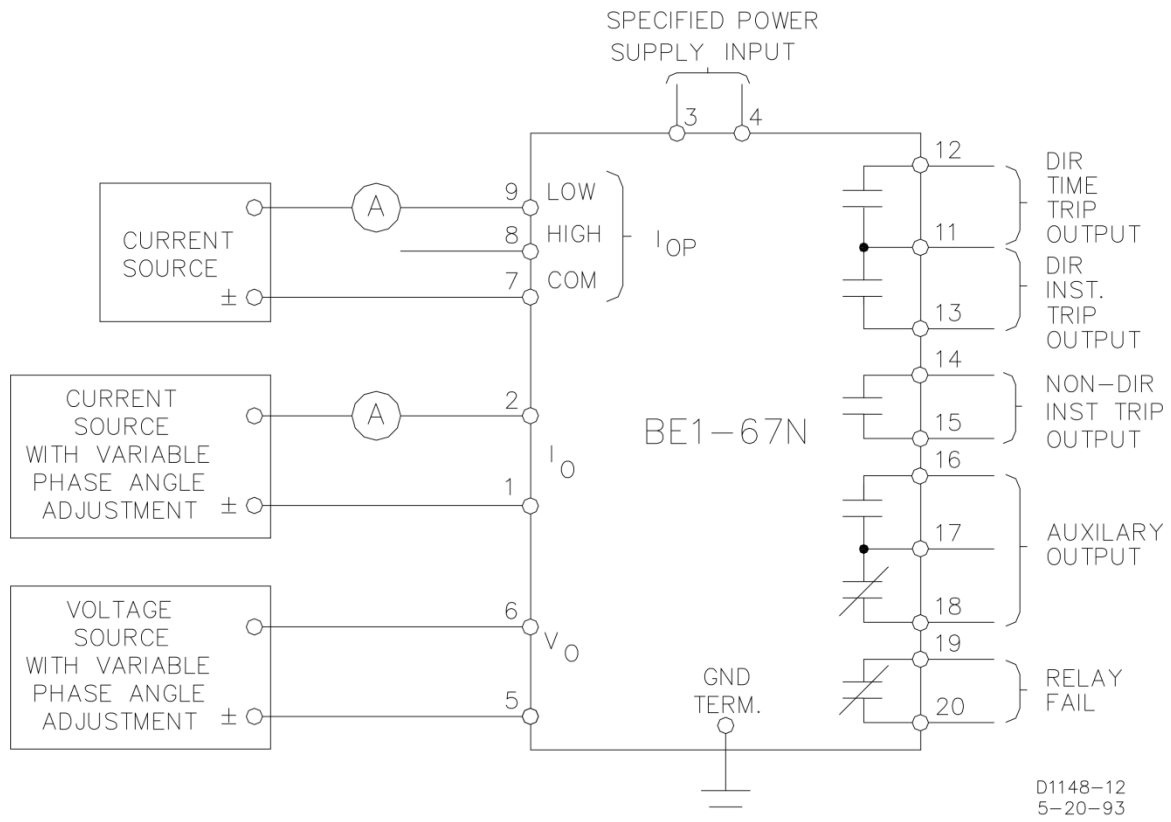

Figure 5-1. Typical Test Connections

2. Adjust the Tap Calibration control fully clockwise.
3. Set the Time Dial at 99.
4. Set the Tap Selector switch in position A.
5. Adjust the Directional, Instantaneous Overcurrent control and Non-Directional, Instantaneous Overcurrent control fully clockwise.
6. Place the Characteristic Angle switch in the 0° position.
7. Set the Polarizing Source Select switch (locator A of Figure 2-2) for dual polarization (both the V_o and I_o switches up).

8. Apply the proper power supply voltage to relay case terminals 3 and 4. (Refer to Section 1, *General Information* for the voltage range for each power supply type.)
9. Insert the relay connection plugs.
10. Verify that the Power, Directional Timing Inhibit, and Directional Instantaneous Inhibit indicators are lit.
11. Verify that the Relay Failure output contacts at case terminals 19 and 20 function properly. The contacts should be open with relay operating power applied and closed with relay operating power removed. When the upper connection plus is removed, the case shorting bar should place a short circuit across terminals 19 and 20.

NOTE

The test procedures provided here for time overcurrent pickup, non-directional instantaneous overcurrent pickup, and directional instantaneous overcurrent pickup are performed using only voltage polarizing (V_o) inputs.

Time Overcurrent Pickup Test

1. Perform the *Preliminary Test Setup* before proceeding with time overcurrent pickup testing.
2. Adjust the polarizing input voltage source (V_o) for 4 Vac at a 0° phase angle.
3. Adjust the I_o input current source for 0.25 Aac (low range) or 0.75 Aac (high range) at a 0° phase angle.
4. Verify the minimum pickup point of the range by slowly rotating the Tap Calibration control counterclockwise until the Timing indicator lights.
5. Rotate the Tap Calibration control fully clockwise. The Timing indicator should turn off. Slowly increase the magnitude of the input current until the Timing indicator lights. The input current level should be within $\pm 5\%$ of 0.375 Aac (low range) or 1.125 Aac (high range). This verifies the pickup accuracy of the tap A setting.
6. If verification of the remaining Tap Selector positions is desired, adjust the Tap Selector to its next clockwise position, when slowly increase the input current magnitude until the Timing Indicator lights. Observe that the current level is within $\pm 5\%$ of the value listed in Table 5-1.

NOTE

The Tap Selector position can be changed without disconnecting the current sensing inputs.

Table 5-1. Pickup Values for Tap Selector Positions – Input Ranges 1 and 2

Nominal Range	Tap Selector Switch Position										I_{OP} Terminals
	A	B	C	D	E	F	G	H	I	J	
High	1.125	1.500	2.250	2.625	3.375	3.750	4.500	4.875	5.625	6.000	7 and 8
Low	0.375	0.500	0.750	0.875	1.125	1.250	1.500	1.625	1.875	2.000	7 and 9

Non-Directional, Instantaneous Overcurrent Pickup Test

1. Perform the *Preliminary Test Setup* before proceeding with time overcurrent pickup testing.
2. Adjust the Non-Directional, Instantaneous Overcurrent control fully clockwise.
3. Apply 2.0 Aac input current (I_o).
4. Slowly adjust the Non-Directional, Instantaneous Overcurrent control counterclockwise until the non-directional instantaneous trip output activates (contacts at terminals 14 and 15 close).
5. Adjust the polarizing voltage source (V_o) for 4 Vac at a 90° phase angle. The relay should remain in a tripped state.

6. Reduce I_o to 1.8 Aac.
7. Confirm that the non-directional instantaneous trip output contacts at terminals 14 and 15 open.
8. Adjust the Non-Directional Instantaneous Overcurrent control fully clockwise.

Directional, Instantaneous Overcurrent Pickup Test

1. Perform the *Preliminary Test Setup* before proceeding with time overcurrent pickup testing.
2. Set the polarizing voltage source (V_o) for 4.0 Vac at a 0° phase angle.
3. Rotate the Directional, Instantaneous Overcurrent control fully clockwise.
4. Apply 2.0 Aac of I_o .
5. Slowly adjust the Directional, Instantaneous Overcurrent control counterclockwise until the directional instantaneous trip output contacts (terminal 11 and 13) close.
6. Adjust the V_o phase angle until the directional instantaneous trip output contacts open and the Directional Instantaneous Inhibit indicator lights. The V_o phase angle should be $75^\circ \pm 5^\circ$.
7. Adjust the V_o phase angle for 0° . The directional instantaneous trip output contacts should close.
8. Reduce I_o to 1.8 Aac.
9. Confirm that the directional instantaneous trip output contacts open.
10. Rotate the Directional, Instantaneous Overcurrent control fully clockwise.

V_o Directional Verification

For the following tests, it will be necessary to adjust and monitor the magnitude of voltage and current as well as the phase angle relationship between sensing quantities. The results should be recorded on polar graph paper to understand the significance of the results. Blank polar graph forms are provided in Appendix B, *Polar Graph Forms*.

1. Perform the *Preliminary Test Setup* before proceeding with time overcurrent pickup testing.
2. Adjust the polarizing voltage source (V_o) for 4.0 Vac at a 0° phase angle.
3. With the I_o current source set at 1.0 Aac (low range) or 2.0 Aac (high range), and the Characteristic Angle switch set at 0° , vary the phase angle of the V_o input through 360° and note the phase angles within which the Directional Timing Inhibit indicator turns off. When these results are illustrated on a polar plot, the graph should resemble a v-shaped line through the origin from -75° to $+75^\circ$, $\pm 5^\circ$. This plot defines the trip region as shown in Figure 5-2.

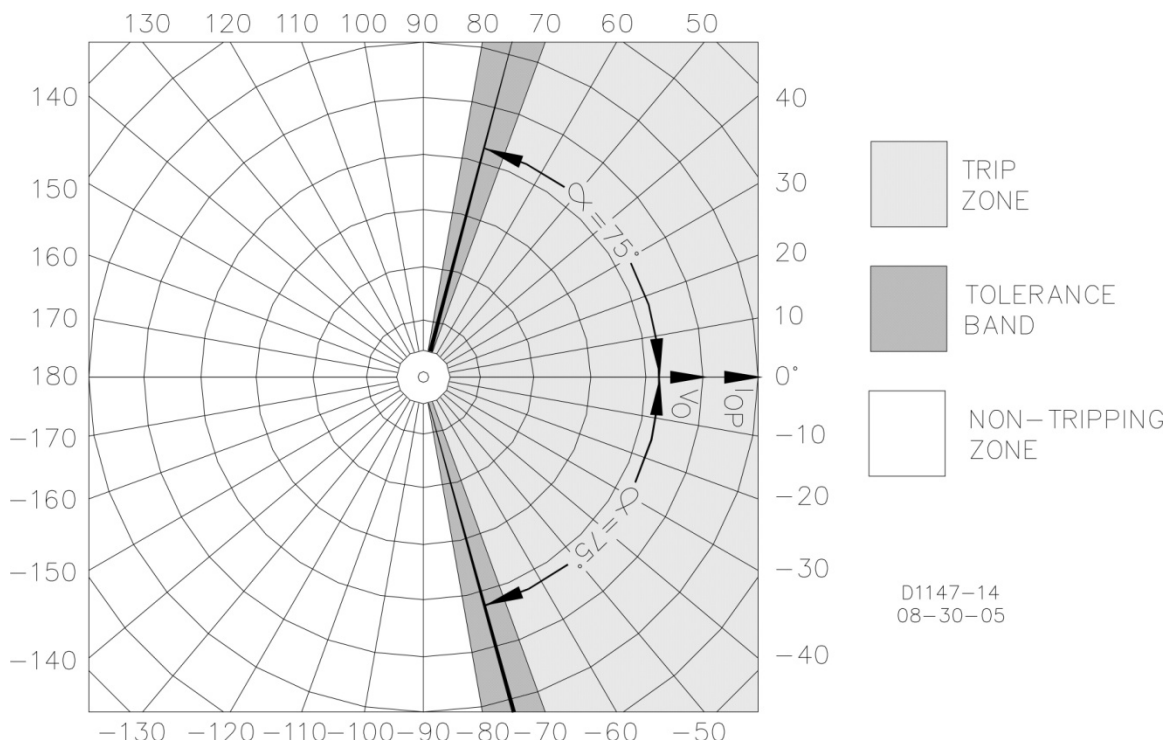

Figure 5-2. Trip Zone Using V_o as Polarizing Source (Char. Angle = 0°)

4. Place the Characteristic Angle switch in the 60° position.
5. Vary the phase angle of the V_o input through 360° and record the phase angles with which the Directional Timing Inhibit indicator turns off. When these results are illustrated on a polar plot, the graph should resemble a v-shaped line through the origin from -15° to $+135^\circ$, $\pm 5^\circ$. This plot defines the trip region as shown in Figure 5-3.

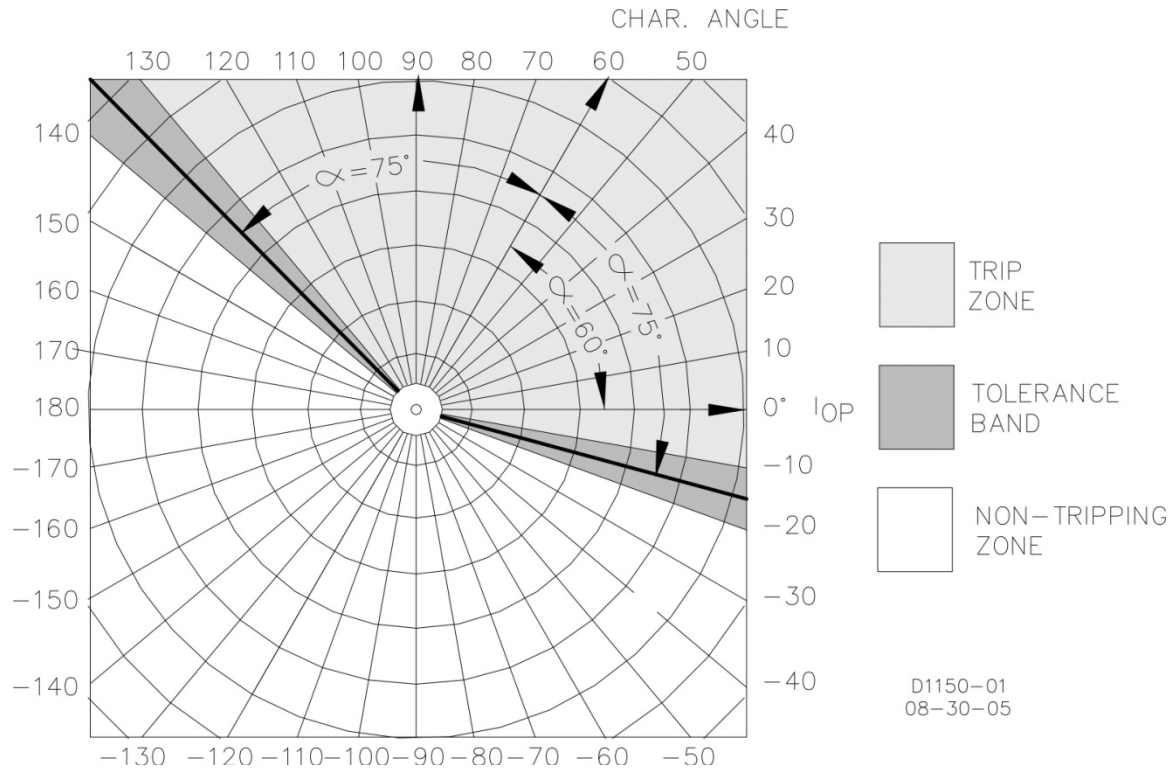

Figure 5-3. Trip Zone Using V_o as Polarizing Source (Char. Angle = 60°)

I_o Directional Verification

For the following tests, it will be necessary to adjust and monitor the magnitude of voltage and current as well as the phase angle relationship between sensing quantities. The results should be recorded on polar graph paper to understand the significance of the results. Blank polar graph forms are provided in Appendix B, *Polar Graph Forms*.

1. Perform the *Preliminary Test Setup* before proceeding with time overcurrent pickup testing.
2. Apply 1.0 Aac of polarizing current (I_o) at a phase angle of 0°.
3. With the I_o current source set at 1.0 Aac (low range) or 2.0 Aac (high range), and the Characteristic Angle switch set at 0°, vary the phase angle of the V_o input through 360° and note the phase angles within which the Directional Timing Inhibit indicator turns off. When these results are illustrated on a polar plot, the graph should resemble a v-shaped line through the origin from -75° to $+75^\circ$, $\pm 5^\circ$. This plot defines the trip region as shown in Figure 5-4.

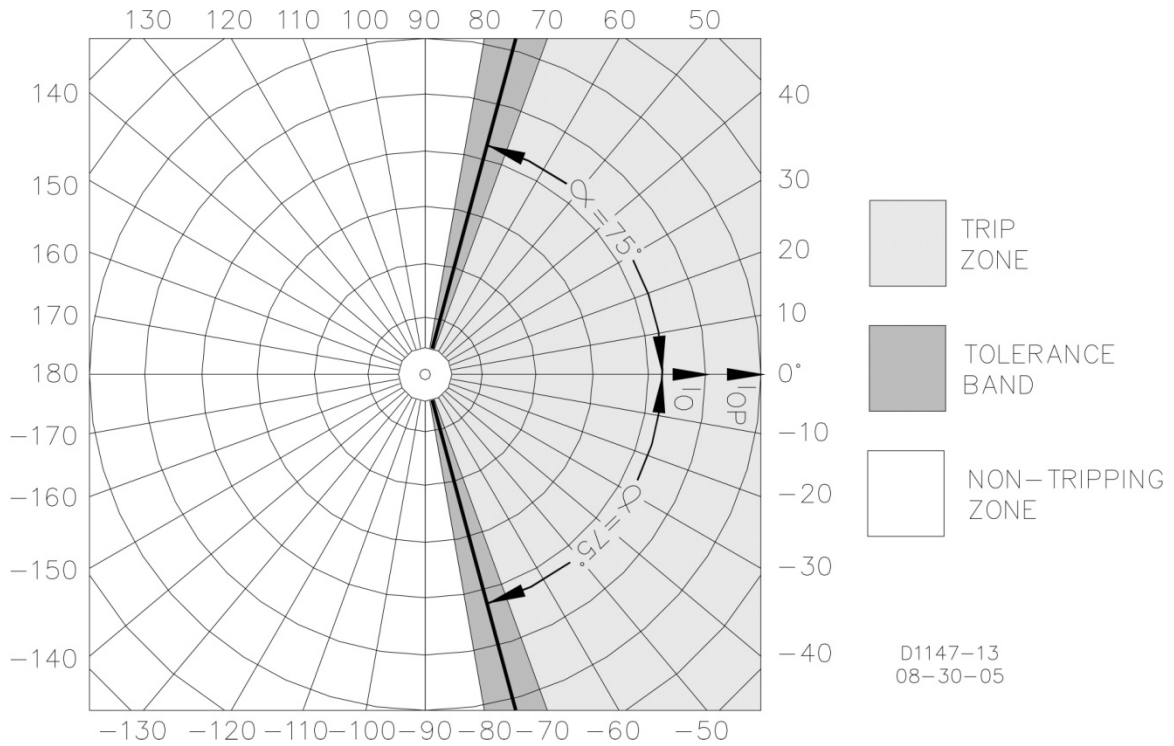

Figure 5-4. Trip Zone Using IO as Polarizing Source (Char. Angle = 0°)

Timing Curve Verification

Connect the relay as shown in Figure 5-1. For convenience, verification of timing may be performed at a low current level. Timing will be measured from the point that the sensed current is applied until the output contact changes state. The equipment needed to accomplish this task will need to step from 0 to 1.875 Aac (low range) or 0 to 5.625 Aac (high range).

Table 5-2 lists checkpoints for each timing characteristic. Use the Time Overcurrent Characteristic Curve Selector switch (locator C of Figure 2-2) to select the desired characteristic.

Table 5-2. Expected Timing at Five Times Pickup

Timing Type	Selector Option	Expected Times at Indicated Time Dial Setting *	
		00	10
B1	3	0.066 s	0.194 s
B2	1	0.587 s	3.410 s
B3	5	0.103 s	0.494 s
B4	2	0.168 s	0.875 s
B5	4	0.149 s	0.722 s
B6	6	0.126 s	0.551 s
B7	7	0.195 s	1.011 s
B8	0	0.329 s	1.790 s
E2	8	1.560 s	9.060 s
E4	9	0.130 s	0.540 s
E5	A	0.233 s	1.190 s
E6	B	0.160 s	0.770 s
E7	C, D, E, F	0.130 s	0.480 s

* Accuracy, with Tap Calibration control rotated fully clockwise, is $\pm 5\%$ or 50 milliseconds (whichever is greater) within values shown graphically on the published characteristic curves.

1. Set the Tap Selector at position A and rotate the Tap Calibration control fully clockwise. Rotate the Directional and Non-Directional Instantaneous Overcurrent controls fully clockwise. Set the Time Dial at 00.
2. Adjust the I_o current source for 0.375 Aac (low range) or 1.125 Aac (high range) and apply this current to the sensing inputs. Voltage ($V_o = 4.0$ Vac) will also need to be applied to the sensing input of the directional element for this test. The phase angle between current and voltage should be adjusted so that the Timing indicator lights when the pickup current is applied. Adjust the Tap Calibration control (if required) so that the Timing indicator is lit. This sets the relay pickup for the following steps.
3. Connect a counter to monitor the time interval from initiation of the timing condition to the output contact transition at terminals 11 and 12.
4. Switch the sensing current to 1.875 Aac (low range) or 5.625 Aac (high range). (This is five times the level set in step 2.) Monitor the time required for the output contact to change state and compare the time with the appropriate value in Table 5-2.
5. Set the Time Dial at 10 and repeat step 4.

TEST PROCEDURES FOR SENSING INPUT RANGES 3 AND 4

The following paragraphs contain procedures for verifying the operation and timing curves of a BE1-67N relay with sensing input range of 3 or 4.

Operational Test Procedure

Following a preliminary test setup, BE1-67N operational testing consists of a time overcurrent pickup test, an instantaneous overcurrent pickup test (directional and non-directional), V_o directional verification, and I_o directional verification.

Preliminary Test Setup

1. Connect the BE1-67N relay as shown in Figure 5-1.
2. Adjust the Tap Calibration control fully clockwise.
3. Set the Time Dial at 99.
4. Set the Tap Selector switch in position A.
5. Adjust the Directional, Instantaneous Overcurrent control and Non-Directional, Instantaneous Overcurrent control fully clockwise.
6. Place the Characteristic Angle switch in the 0° position.
7. Set the Polarizing Source Select switch (locator A of Figure 2-2) for dual polarization (both the V_o and I_o switches up).
8. Apply the proper power supply voltage to relay case terminals 3 and 4. (Refer to Section 1, *General Information* for the voltage range for each power supply type.)
9. Insert the relay connection plugs.
10. Verify that the Power, Directional Timing Inhibit, and Directional Instantaneous Inhibit indicators are lit.
11. Verify that the Relay Failure output contacts at case terminals 19 and 20 function properly. The contacts should be open with relay operating power applied and closed with relay operating power removed. When the upper connection plus is removed, the case shorting bar should place a short circuit across terminals 19 and 20.

NOTE

The test procedures provided here for time overcurrent pickup, non-directional instantaneous overcurrent pickup, and directional instantaneous overcurrent pickup are performed using only voltage polarizing (V_o) inputs.

Time Overcurrent Pickup Test

1. Perform the *Preliminary Test Setup* before proceeding with time overcurrent pickup testing.
2. Adjust the polarizing input voltage source (V_o) for 4 Vac at a 0° phase angle.
3. Adjust the I_o input current source for 0.05 Aac (low range) or 0.15 Aac (high range) at a 0° phase angle.
4. Verify the minimum pickup point of the range by slowly rotating the Tap Calibration control counterclockwise until the Timing indicator lights.
5. Rotate the Tap Calibration control fully clockwise. The Timing indicator should turn off. Slowly increase the magnitude of the input current until the Timing indicator lights. The input current level should be within $\pm 5\%$ of 0.075 Aac (low range) or 0.225 Aac (high range). This verifies the pickup accuracy of the tap A setting.
6. If verification of the remaining Tap Selector positions is desired, adjust the Tap Selector to its next clockwise position, when slowly increase the input current magnitude until the Timing Indicator lights. Observe that the current level is within $\pm 5\%$ of the value listed in Table 5-3.

NOTE

The Tap Selector position can be changed without disconnecting the current sensing inputs.

Table 5-3. Pickup Values for Tap Selector Positions – Input Ranges 3 and 4

Nominal Range	Tap Selector Switch Position										I_{OP} Terminals
	A	B	C	D	E	F	G	H	I	J	
High	0.225	0.300	0.450	0.525	0.675	0.750	0.900	0.975	1.125	1.200	7 and 8
Low	0.075	0.100	0.150	0.175	0.225	0.250	0.300	0.325	0.375	0.400	7 and 9

Non-Directional, Instantaneous Overcurrent Pickup Test

1. Perform the *Preliminary Test Setup* before proceeding with time overcurrent pickup testing.
2. Adjust the Non-Directional, Instantaneous Overcurrent control fully clockwise.
3. Apply 0.4 Aac input current (I_o).
4. Slowly adjust the Non-Directional, Instantaneous Overcurrent control counterclockwise until the non-directional instantaneous trip output activates (contacts at terminals 14 and 15 close).
5. Adjust the polarizing voltage source (V_o) for 4 Vac at a 90° phase angle. The relay should remain in a tripped state.
6. Reduce I_o to 0.35 Aac.
7. Confirm that the non-directional instantaneous trip output contacts at terminals 14 and 15 open.
8. Adjust the Non-Directional Instantaneous Overcurrent control fully clockwise.

Directional, Instantaneous Overcurrent Pickup Test

1. Perform the *Preliminary Test Setup* before proceeding with time overcurrent pickup testing.
2. Set the polarizing voltage source (V_o) for 4.0 Vac at a 0° phase angle.
3. Rotate the Directional, Instantaneous Overcurrent control fully clockwise.
4. Apply 0.4 Aac of I_o .
5. Slowly adjust the Directional, Instantaneous Overcurrent control counterclockwise until the directional instantaneous trip output contacts (terminal 11 and 13) close.
6. Adjust the V_o phase angle until the directional instantaneous trip output contacts open and the Directional Instantaneous Inhibit indicator lights. The V_o phase angle should be $75^\circ \pm 5^\circ$.
7. Adjust the V_o phase angle for 0° . The directional instantaneous trip output contacts should close.
8. Reduce I_o to 0.35 Aac.

9. Confirm that the directional instantaneous trip output contacts open.
10. Rotate the Directional, Instantaneous Overcurrent control fully clockwise.

V_o Directional Verification

For the following tests, it will be necessary to adjust and monitor the magnitude of voltage and current as well as the phase angle relationship between sensing quantities. The results should be recorded on polar graph paper to understand the significance of the results. Blank polar graph forms are provided in Appendix B, *Polar Graph Forms*.

1. Perform the *Preliminary Test Setup* before proceeding with time overcurrent pickup testing.
2. Adjust the polarizing voltage source (V_o) for 4.0 Vac at a 0° phase angle.
3. With the I_o current source set at 0.2 Aac (low range) or 0.4 Aac (high range), and the Characteristic Angle switch set at 0° , vary the phase angle of the V_o input through 360° and note the phase angles within which the Directional Timing Inhibit indicator turns off. When these results are illustrated on a polar plot, the graph should resemble a v-shaped line through the origin from -75° to $+75^\circ$, $\pm 5^\circ$. This plot defines the trip region as shown in Figure 5-2.
4. Place the Characteristic Angle switch in the 60° position.
5. Vary the phase angle of the V_o input through 360° and record the phase angles with which the Directional Timing Inhibit indicator turns off. When these results are illustrated on a polar plot, the graph should resemble a v-shaped line through the origin from -15° to $+135^\circ$, $\pm 5^\circ$. This plot defines the trip region as shown in Figure 5-3.

I_o Directional Verification

For the following tests, it will be necessary to adjust and monitor the magnitude of voltage and current as well as the phase angle relationship between sensing quantities. The results should be recorded on polar graph paper to understand the significance of the results. Blank polar graph forms are provided in Appendix B, *Polar Graph Forms*.

1. Perform the *Preliminary Test Setup* before proceeding with time overcurrent pickup testing.
2. Apply 1.0 Aac of polarizing current (I_o) at a phase angle of 0° .
3. With the I_o current source set at 0.2 Aac (low range) or 0.4 Aac (high range), and the Characteristic Angle switch set at 0° , vary the phase angle of the V_o input through 360° and note the phase angles within which the Directional Timing Inhibit indicator turns off. When these results are illustrated on a polar plot, the graph should resemble a v-shaped line through the origin from -75° to $+75^\circ$, $\pm 5^\circ$. This plot defines the trip region as shown in Figure 5-4.

Timing Curve Verification

Connect the relay as shown in Figure 5-1. For convenience, verification of timing may be performed at a low current level. Timing will be measured from the point that the sensed current is applied until the output contact changes state. The equipment needed to accomplish this task will need to step from 0 to 0.75 Aac (low range) or 0 to 0.225 Aac (high range).

Table 5-2 lists checkpoints for each timing characteristic. Use the Time Overcurrent Characteristic Curve Selector switch (locator C of Figure 2-2) to select the desired characteristic.

1. Set the Tap Selector at position A and rotate the Tap Calibration control fully clockwise. Rotate the Directional and Non-Directional Instantaneous Overcurrent controls fully clockwise. Set the Time Dial at 00.
2. Adjust the I_o current source for 0.75 Aac (low range) or 0.225 Aac (high range) and apply this current to the sensing inputs. Voltage ($V_o = 4.0$ Vac) will also need to be applied to the sensing input of the directional element for this test. The phase angle between current and voltage should be adjusted so that the Timing indicator lights when the pickup current is applied. Adjust the Tap Calibration control (if required) so that the Timing indicator is lit. This sets the relay pickup for the following steps.
3. Connect a counter to monitor the time interval from initiation of the timing condition to the output contact transition at terminals 11 and 12.
4. Switch the sensing current to 0.75 Aac (low range) or 0.225 Aac (high range). (This is five times the level set in step 2.) Monitor the time required for the output contact to change state and compare the time with the appropriate value in Table 5-2.
5. Set the Time Dial at 10 and repeat step 4.

APPENDIX A • CHARACTERISTIC CURVES

TABLE OF CONTENTS

APPENDIX A • CHARACTERISTIC CURVES.....	A-1
BE1-67N TIME OVERCURRENT CURVES.....	A-1

Figures

Figure A-1. Timing Type B1, Short Inverse (Switch Position 3).....	A-2
Figure A-2. Timing Type B2, Long Inverse (Switch Position 1).....	A-3
Figure A-3. Timing Type B3, Definite Time (Switch Position 5).....	A-4
Figure A-4. Timing Type B4, Moderate Inverse (Switch Position 2).....	A-5
Figure A-5. Timing Type B5, Inverse (Switch Position 4).....	A-6
Figure A-6. Timing Type B6, Very Inverse (Switch Position 6).....	A-7
Figure A-7. Timing Type B7, Extremely Inverse (Switch Position 7).....	A-8
Figure A-8. Timing Type E2, BS 142 Long Inverse (Switch Position 8).....	A-9
Figure A-9. Timing Type E4, BS 132 Inverse (Switch Position 9).....	A-10
Figure A-10. Timing Type E5, BS 142 Inverse (Switch Position A).....	A-11
Figure A-11. Timing Type E6, BS 142 Very Inverse (Switch Position B).....	A-12
Figure A-12. Timing Type E7, BS 142 Extremely Inverse (Switch Position C, D, E, F).....	A-13

Tables

Table A-1. Characteristic Curves and Switch Positions	A-1
-------------------------------------------------------------	-----

This page intentionally left blank.

APPENDIX A • CHARACTERISTIC CURVES

BE1-67N TIME OVERCURRENT CURVES

BE1-67N time overcurrent curves are illustrated in Figures A-1 through A-12. Table A-1 lists each curve along with the corresponding characteristic curve selector switch position.

Table A-1. Characteristic Curves and Switch Positions

Switch Position	Characteristic Curve	Characteristic Description	Figure
3	B1	Short Inverse	A-1
1	B2	Long Inverse	A-2
5	B3	Definite	A-3
2	B4	Moderately Inverse	A-4
4	B5	Inverse	A-5
6	B6	Very Inverse	A-6
7	B7	Extremely Inverse	A-7
8	E2	Long Inverse (BS 142)	A-8
9	E4	Inverse (1.3 s, BS 142)	A-9
A	E5	Inverse (2.9 s, BS 142)	A-10
B	E6	Very Inverse (BS 142)	A-11
C, D, E, F	E7	Extremely Inverse (BS 142)	A-12

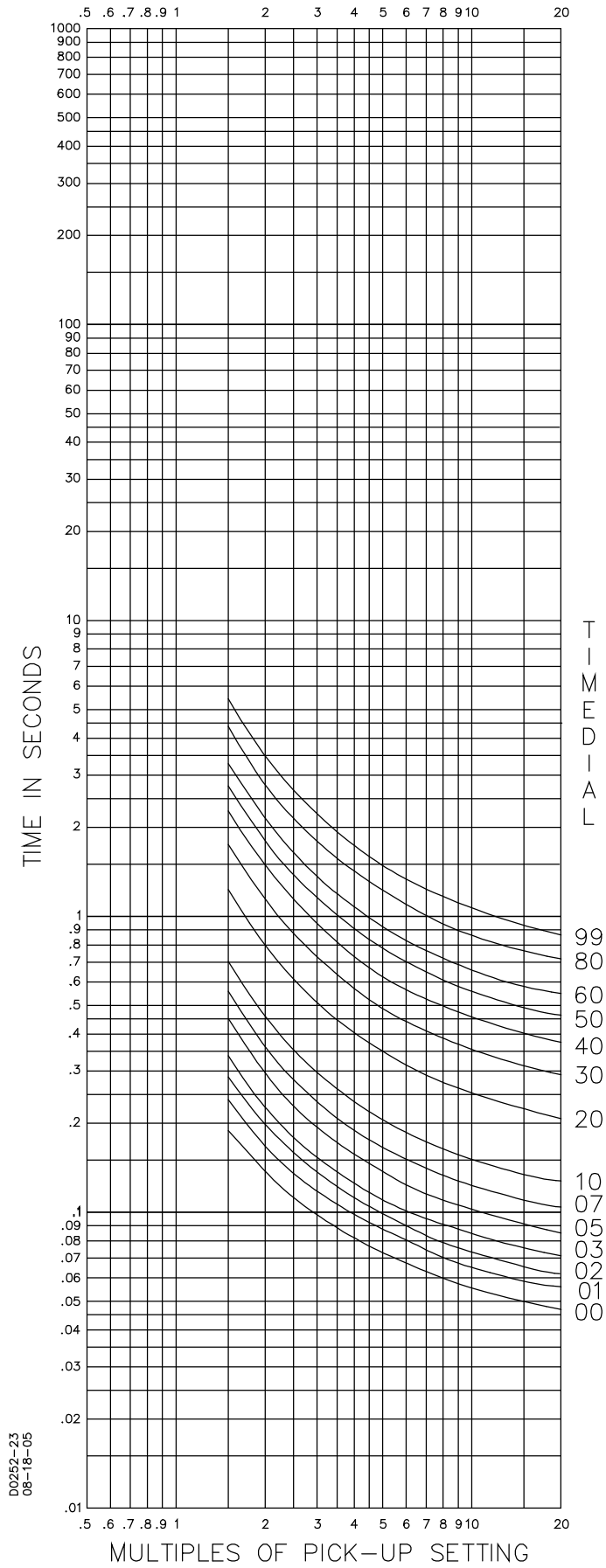

Figure A-1. Timing Type B1, Short Inverse (Switch Position 3)

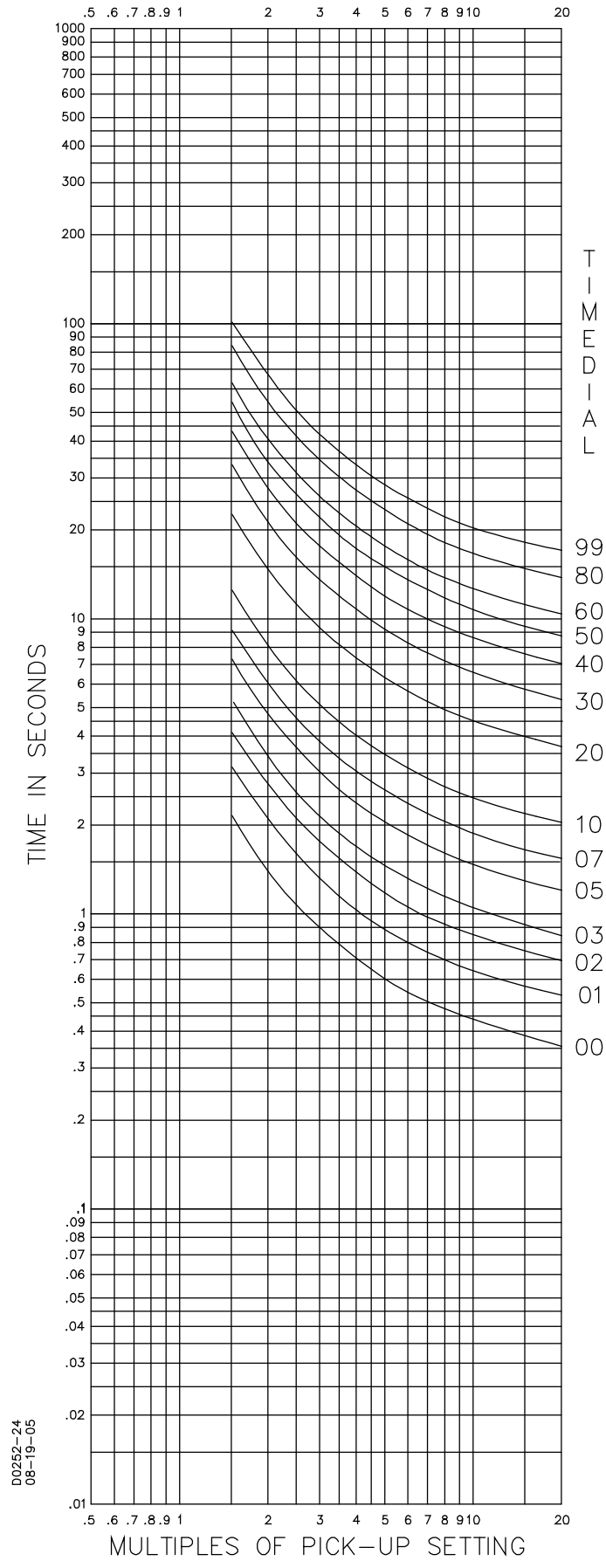

Figure A-2. Timing Type B2, Long Inverse (Switch Position 1)

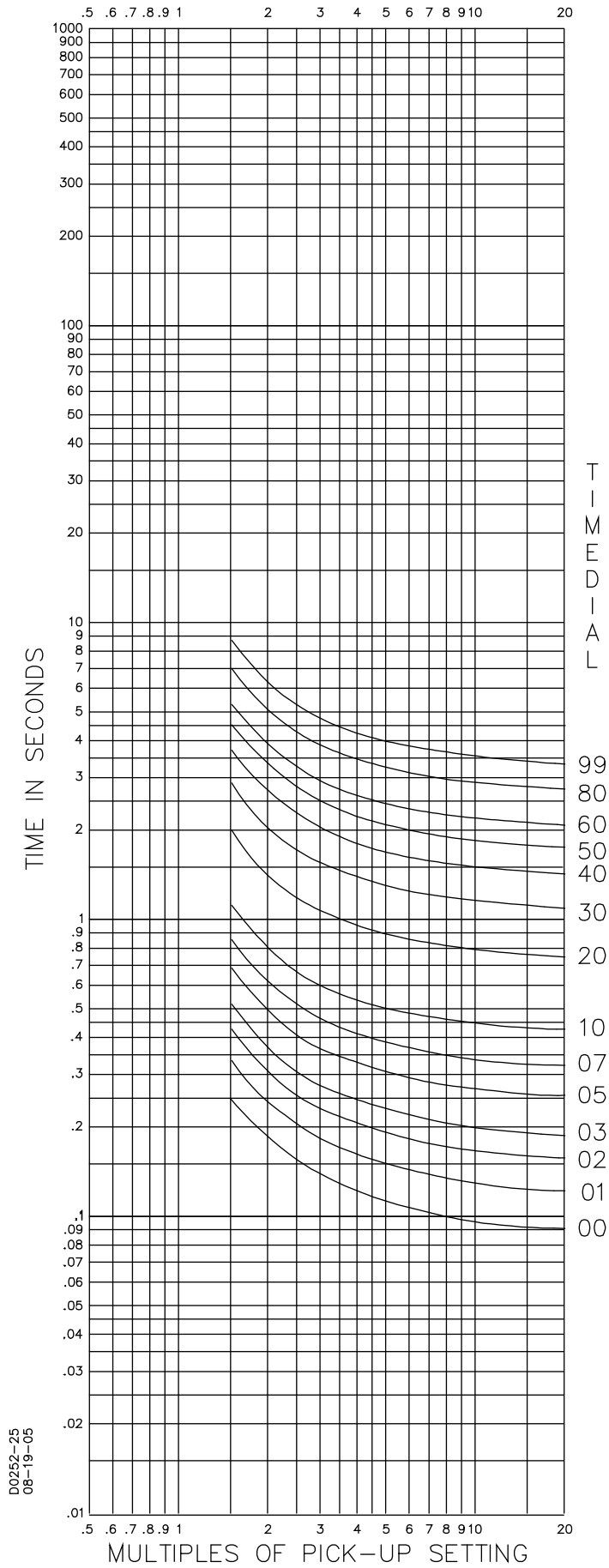

Figure A-3. Timing Type B3, Definite Time (Switch Position 5)

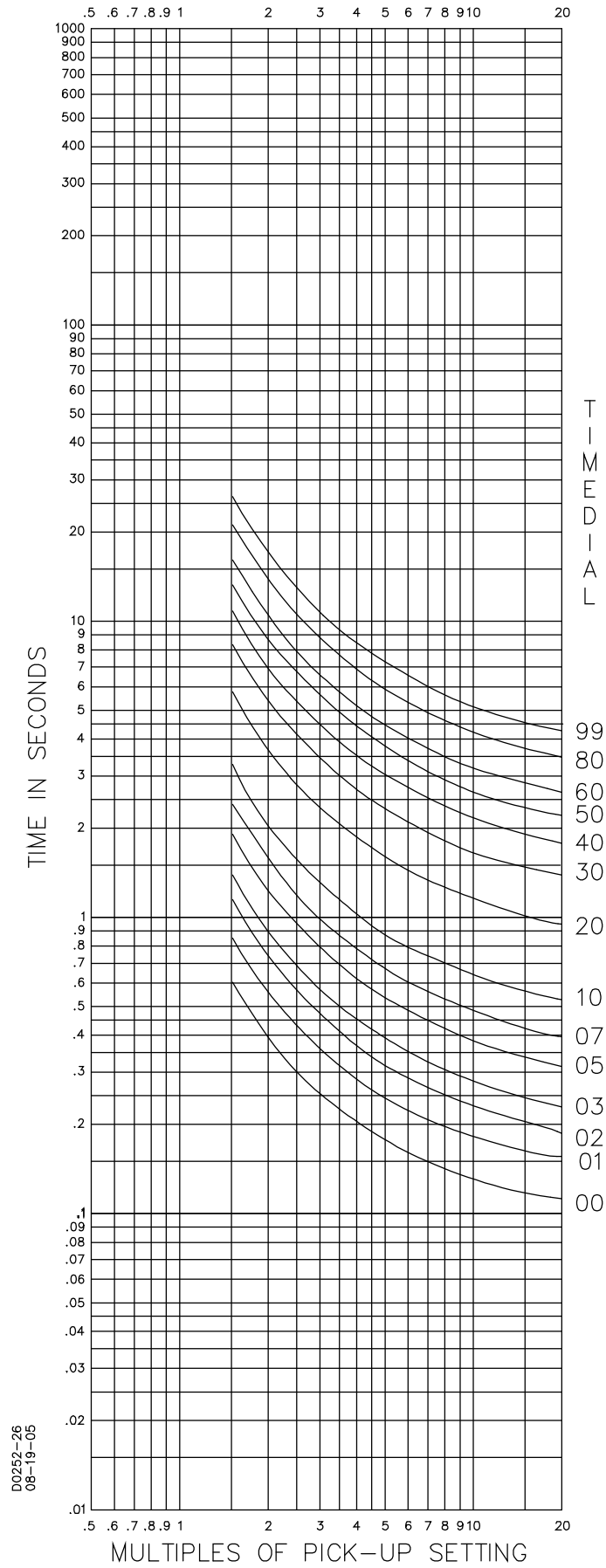

Figure A-4. Timing Type B4, Moderate Inverse (Switch Position 2)

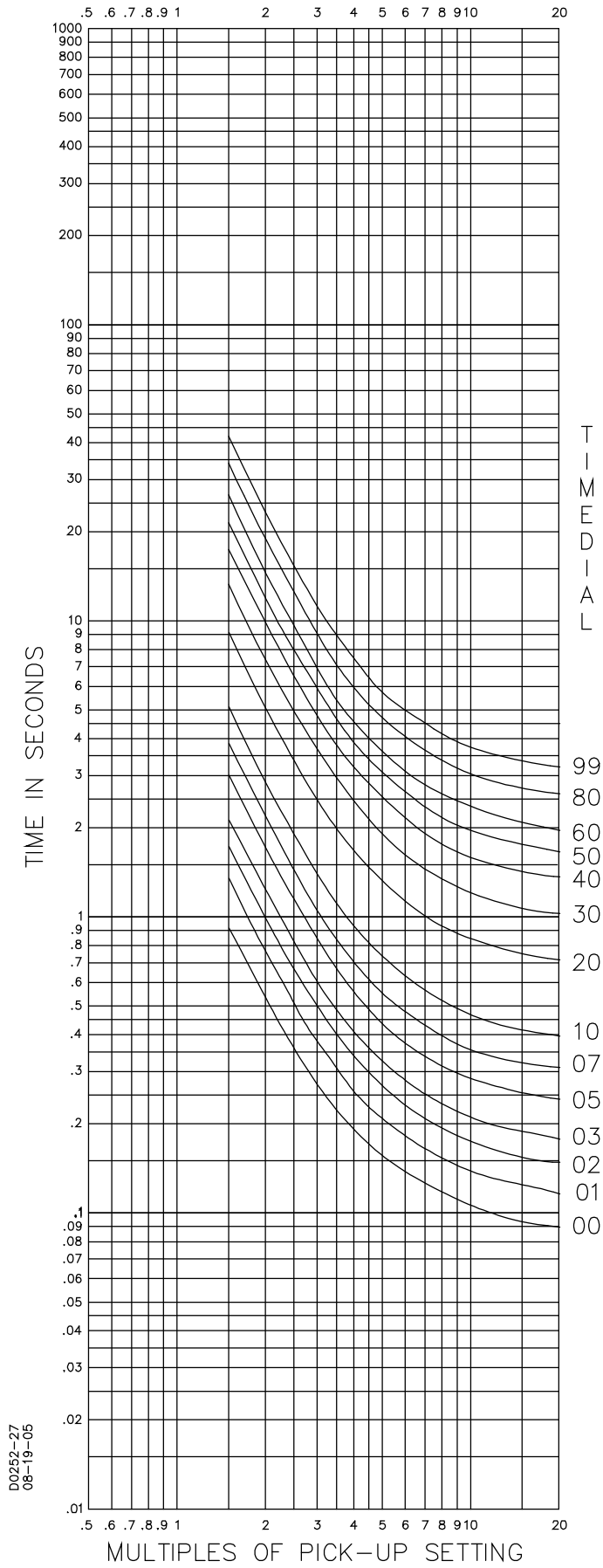

Figure A-5. Timing Type B5, Inverse (Switch Position 4)

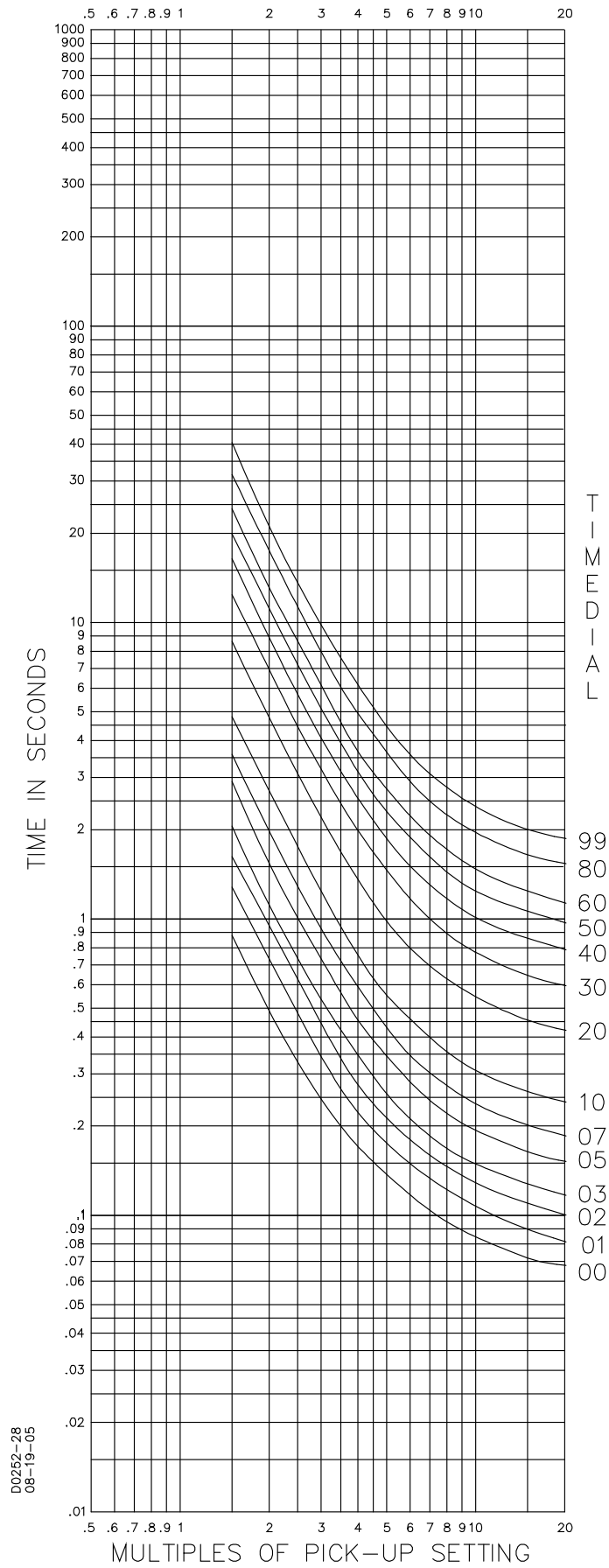

Figure A-6. Timing Type B6, Very Inverse (Switch Position 6)

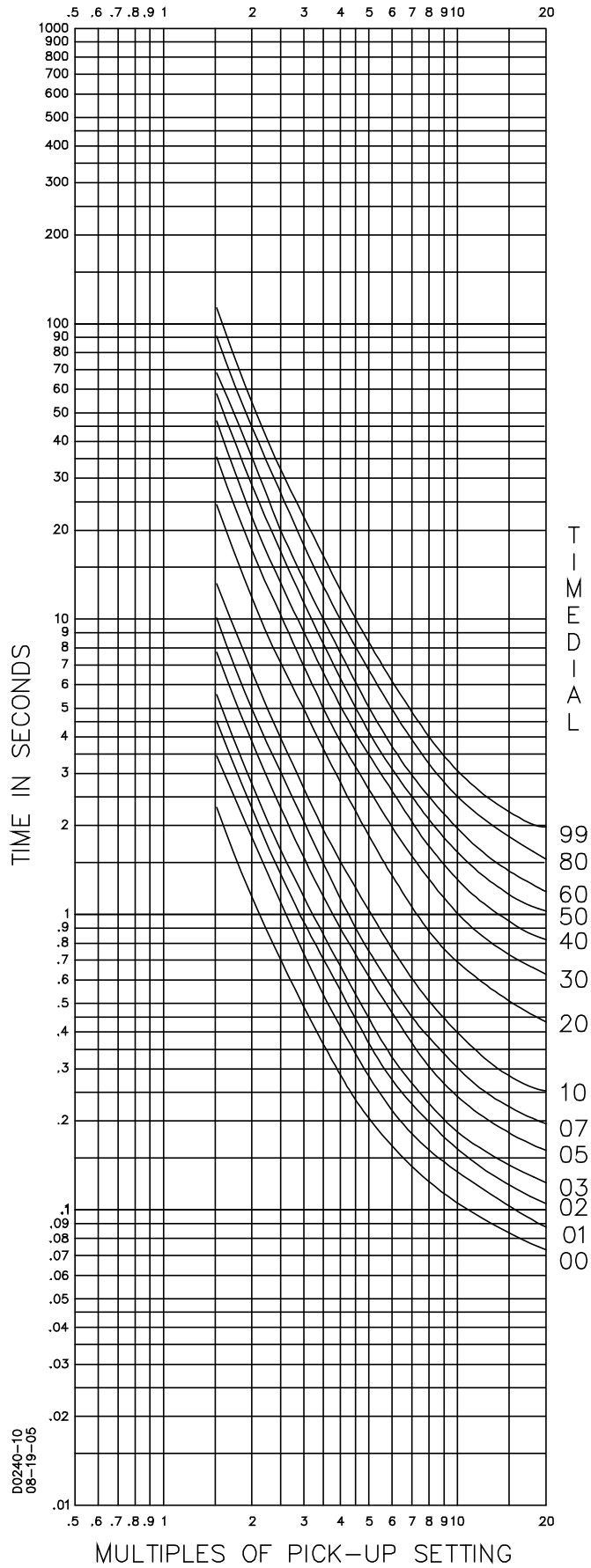

Figure A-7. Timing Type B7, Extremely Inverse (Switch Position 7)

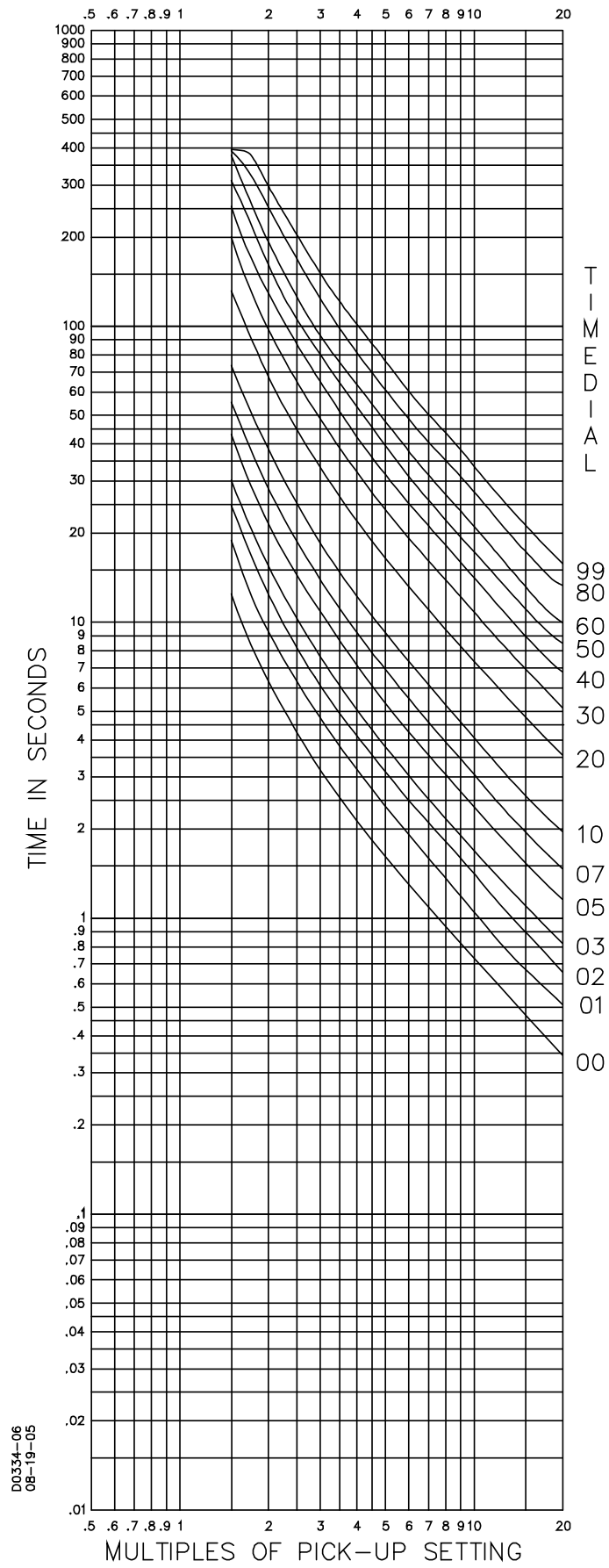

Figure A-8. Timing Type E2, BS 142 Long Inverse (Switch Position 8)

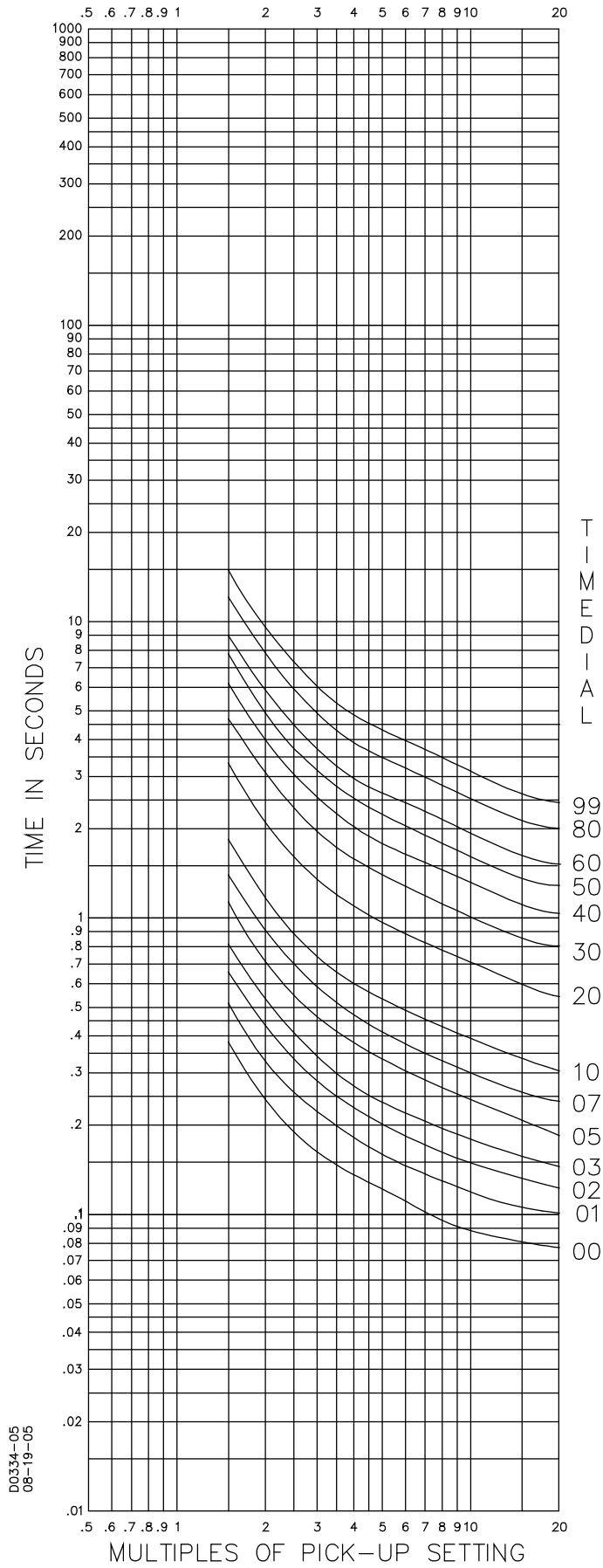

Figure A-9. Timing Type E4, BS 132 Inverse (Switch Position 9)

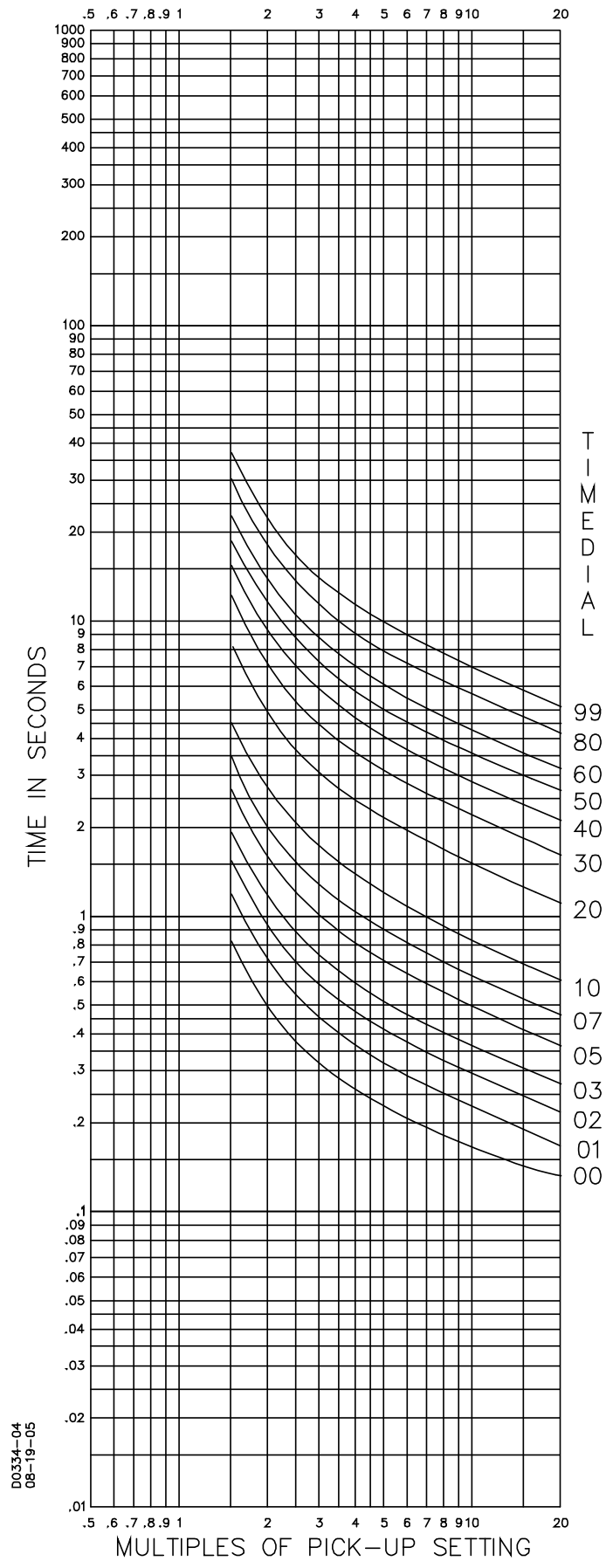

Figure A-10. Timing Type E5, BS 142 Inverse (Switch Position A)

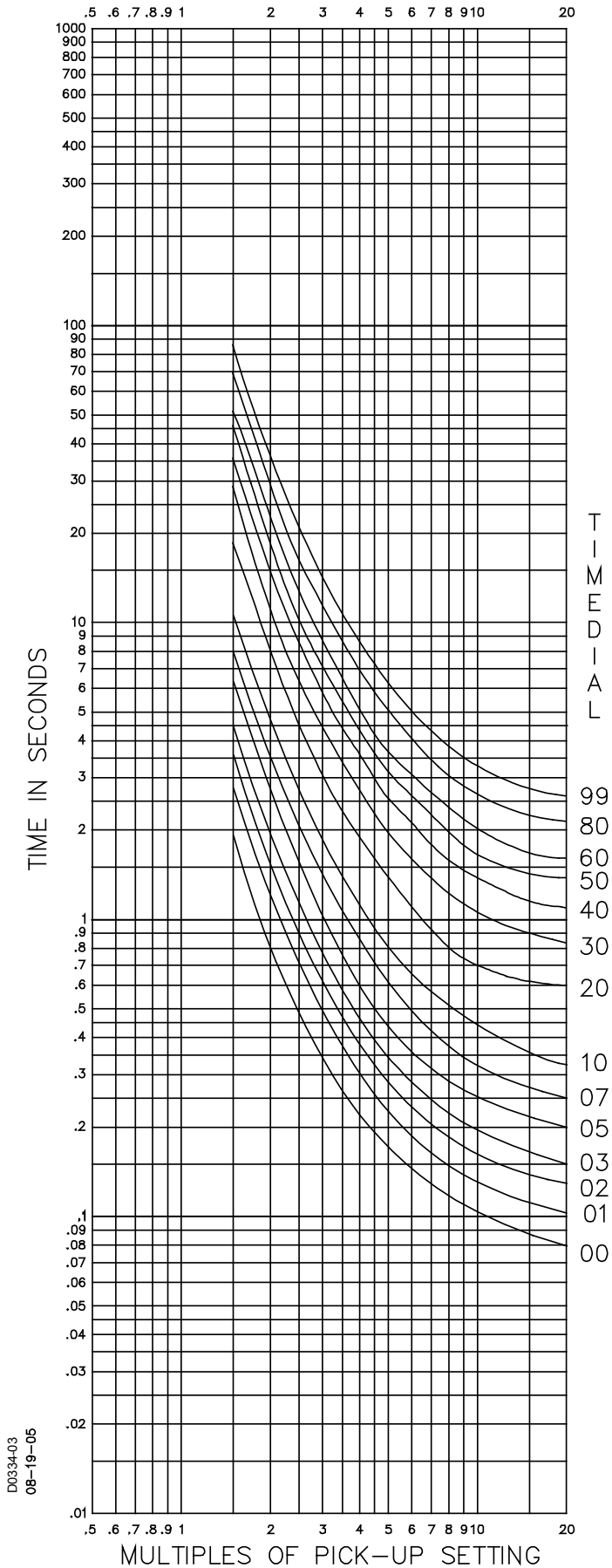

Figure A-11. Timing Type E6, BS 142 Very Inverse (Switch Position B)

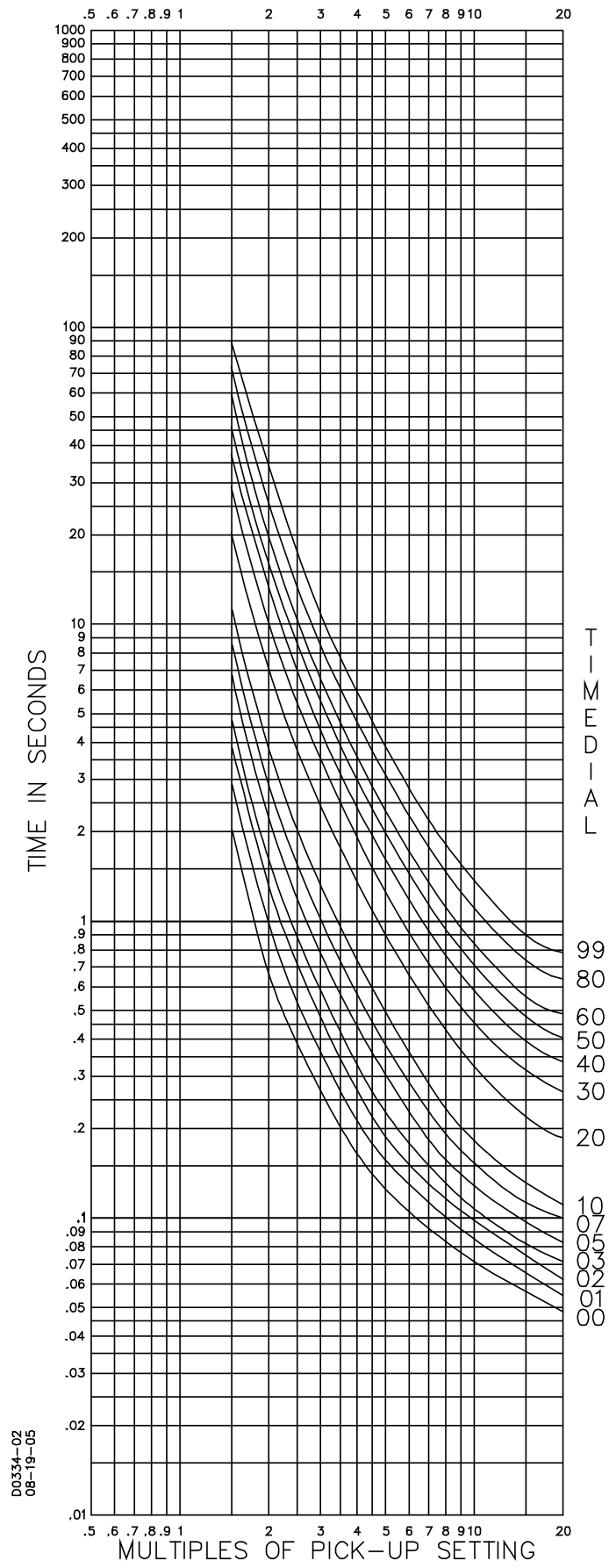
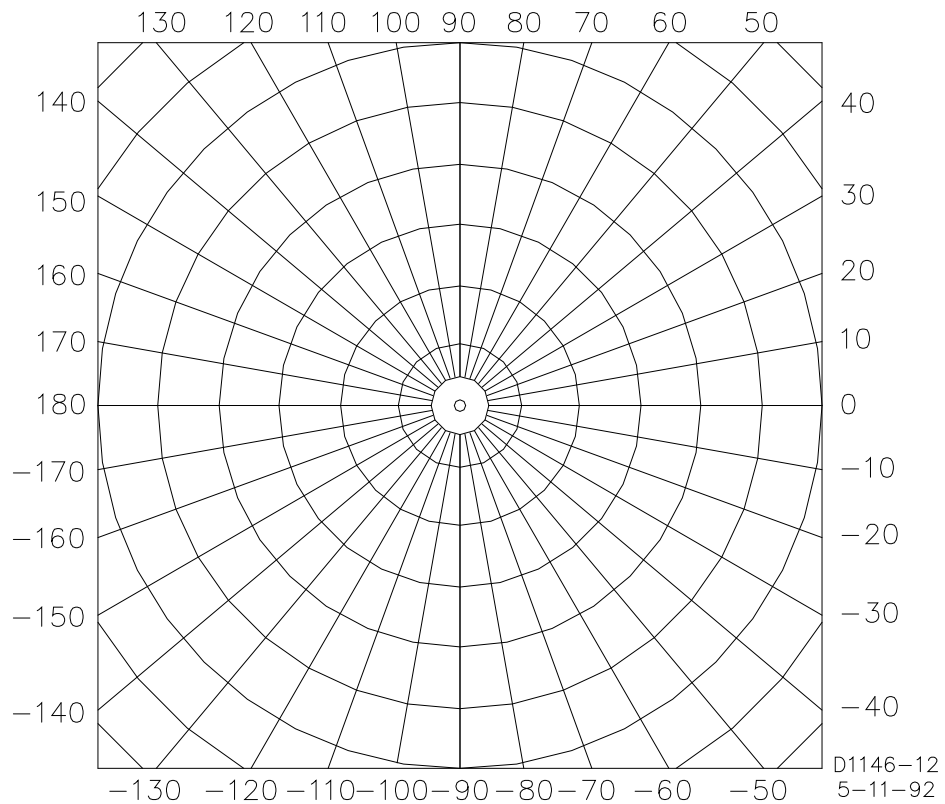
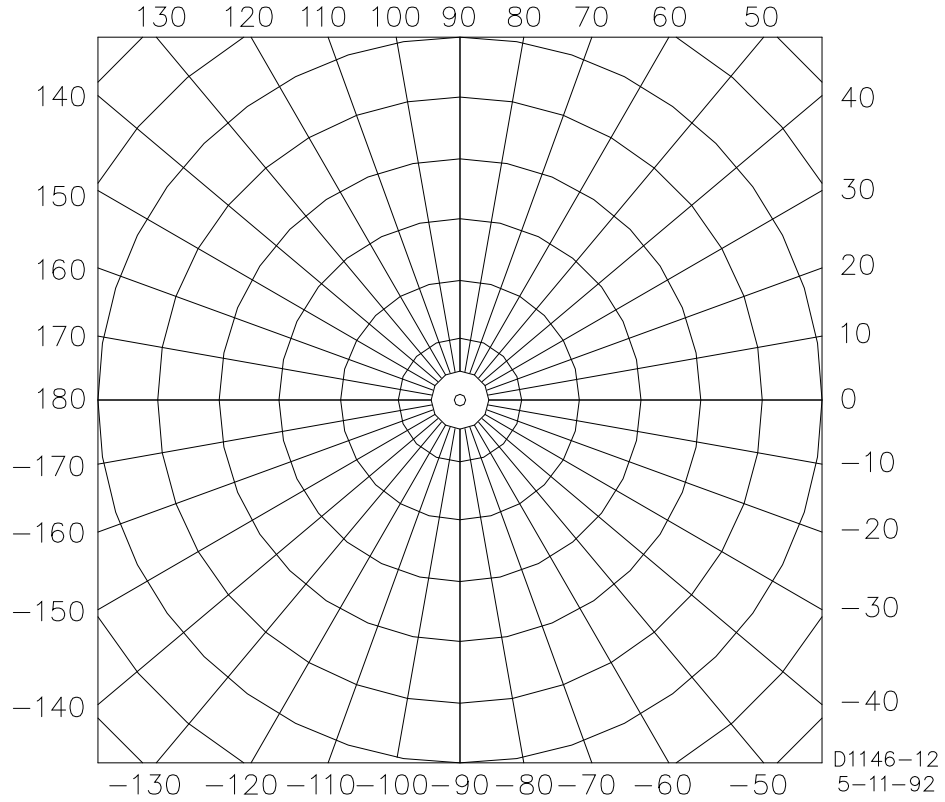

Figure A-12. Timing Type E7, BS 142 Extremely Inverse (Switch Position C, D, E, F)

This page intentionally left blank.

APPENDIX B • POLAR GRAPH FORMS

These polar graph forms may be used to record and interpret the results of the V_o and I_o directional verification test procedures provided in Section 5, *Testing*.



This page intentionally left blank.



12570 State Route 143
Highland IL 62249-1074 USA
Tel: +1 618.654.2341
Fax: +1 618.654.2351
email: info@basler.com

No. 59 Heshun Road Loufeng District (N)
Suzhou Industrial Park
215122 Suzhou
P.R. CHINA
Tel: +86 512.8227.2888
Fax: +86 512.8227.2887
email: chinainfo@basler.com

111 North Bridge Road
15-06 Peninsula Plaza
Singapore 179098
Tel: +65 68.44.6445
Fax: +65 68.44.8902
email: singaporeinfo@basler.com