

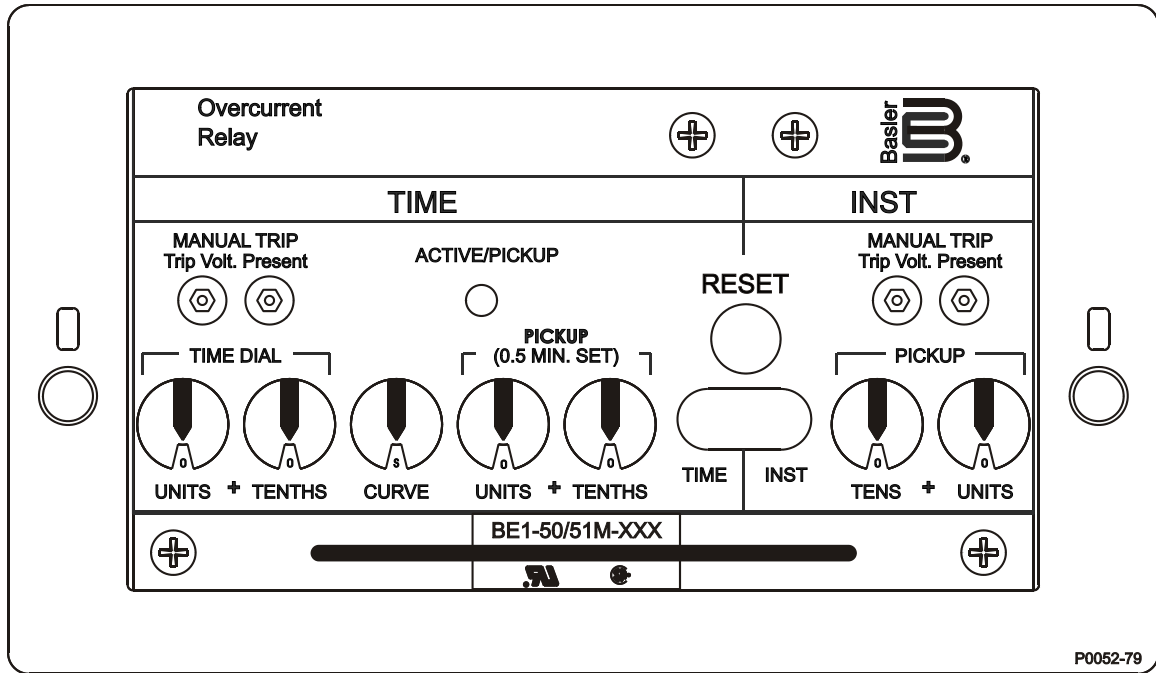



BE1-50/51M Overcurrent Relay

Instruction Manual



 **WARNING:** California's Proposition 65 requires special warnings for products that may contain chemicals known to the state of California to cause cancer, birth defects or other reproductive harm. Please note that by posting this Proposition 65 warning, we are notifying you that one or more of the Proposition 65 listed chemicals may be present in products we sell to you. For more information about the specific chemicals found in this product, please visit <https://www.basler.com/Prop65>.

Preface

This instruction manual provides information about the installation and operation of the BE1-50/51M Overcurrent Relay. To accomplish this, the following information is provided:

- General information and specifications
- Controls and indicators
- Functional description
- Installation and maintenance
- Testing

Conventions Used in this Manual

Important safety and procedural information is emphasized and presented in this manual through warning, caution, and note boxes. Each type is illustrated and defined as follows.

Warning!

Warning boxes call attention to conditions or actions that may cause personal injury or death.

Caution

Caution boxes call attention to operating conditions that may lead to equipment or property damage.

Note

Note boxes emphasize important information pertaining to installation or operation.



12570 State Route 143
Highland IL 62249-1074 USA

www.basler.com

info@basler.com

Tel: +1 618.654.2341

Fax: +1 618.654.2351

© 2024 by Basler Electric

All rights reserved

First printing: April 1992

Warning!

READ THIS MANUAL. Read this manual before installing, operating, or maintaining the BE1-50/51M. Note all warnings, cautions, and notes in this manual as well as on the product. Keep this manual with the product for reference. Only qualified personnel should install, operate, or service this system. Failure to follow warning and cautionary labels may result in personal injury or property damage. Exercise caution at all times.

Basler Electric does not assume any responsibility to compliance or noncompliance with national code, local code, or any other applicable code. This manual serves as reference material that must be well understood prior to installation, operation, or maintenance.

For terms of service relating to this product and software, see the *Commercial Terms of Products and Services* document available at www.basler.com/terms.

This publication contains confidential information of Basler Electric Company, an Illinois corporation. It is loaned for confidential use, subject to return on request, and with the mutual understanding that it will not be used in any manner detrimental to the interests of Basler Electric Company and used strictly for the purpose intended.

It is not the intention of this manual to cover all details and variations in equipment, nor does this manual provide data for every possible contingency regarding installation or operation. The availability and design of all features and options are subject to modification without notice. Over time, improvements and revisions may be made to this publication. Before performing any of the following procedures, contact Basler Electric for the latest revision of this manual.

The English-language version of this manual serves as the only approved manual version.

Revision History

A historical summary of the changes made to this instruction manual is provided below. Revisions are listed in reverse chronological order.

Instruction Manual Revision History

Manual Revision and Date	Change
V, Nov-24	<ul style="list-style-type: none"> Updated manual to reflect changes to main board. Auxiliary contacts are now set with switches instead of jumpers. Target-operating current selection jumpers were added. Updated burden data
U, Feb-24	<ul style="list-style-type: none"> Added China RoHS compliance
T, Jun-22	<ul style="list-style-type: none"> Added a note about EMI suppression in the <i>Installation</i> section Converted manual to latest style Minor text edits
S2, Mar-19	<ul style="list-style-type: none"> Changed Prop 65 to generic version on back of cover page
S1, Oct-18	<ul style="list-style-type: none"> Added Prop 65 warning on back of cover page
S, Dec-15	<ul style="list-style-type: none"> Converted manual to the latest style Added <i>BE1-50/51M Chassis and Case Assembly Modification</i> to the <i>Relay Differences</i> chapter Removed GOST-R certification from the <i>Specifications</i> chapter
R, Sep-11	<ul style="list-style-type: none"> Updated year of IEEE C37.90 specifications in Section 1 Improved description of Locator H (Active/Pickup LED) in Table 2-1 Updated <i>Storage</i> statement in Section 4
Q	<ul style="list-style-type: none"> This revision letter not used
P, Dec-08	<ul style="list-style-type: none"> Improved Figure 5-2, <i>Target Operational Test Setup</i> Corrected sensing input terminal number references listed in Section 3
O	<ul style="list-style-type: none"> This revision letter not used
N, Mar-08	<ul style="list-style-type: none"> Updated front panel drawings to show new target reset button. Added GOST-R to Section 1 Moved content of Section 7, <i>Manual Change Information</i>, to manual <i>Introduction</i> Moved Characteristic Curve graphs from Section 1 to new Appendix A Moved content of Section 6, <i>Maintenance</i>, into Section 4, <i>Installation</i>
M, Nov-00	<ul style="list-style-type: none"> Updated drawings in Section 2 to reflect changes to the PC board Updated the manual to reflect the change in switch call out from SW8 to SW3 Added new functionality to the PICKUP LED. It is now the ACTIVE/PICKUP LED and will be green when active and red when picked up
L, 12-99	<ul style="list-style-type: none"> Changed all references to the current for testing the targets to an ac only type of current

Manual Revision and Date	Change
K, Feb-99	<ul style="list-style-type: none"> • Page 2-2: added description to Locator K for 100 series relays, unit revision Q and previous • Deleted Figure 2-2 from Section 2 and added it to new Section 8 • Page 3-2: added description to Auxiliary Output Contacts for 100 series relays, unit revision R and subsequent • Added new Section 8, <i>Relay Differences</i>
J, May-98	<ul style="list-style-type: none"> • Added Patent Number to Specifications and changed the manual format to reflect current manual styles
I, Jul-97	<ul style="list-style-type: none"> • Corrected Tables 1-3 and 1-4, Figure Number • Changed “pickup setting” to “pickup” on pages 1-7, Time Characteristics equation, page 1-10, Time Reset, and Figures 1-7 through 1-15 • Added Oscillatory to Surge Withstand Capability on page 1-12 • Corrected Figure 1-18 to reflect the correct Time Dial range: 0.5 to 9.9 • Changed Table 7-1 to add ECA and date data
H, Feb-96	<ul style="list-style-type: none"> • Incorporated changes in series 200 relays that added five characteristic curves and changed switch SW8-3 functionality • Changed Section 5, <i>Testing</i>, to incorporate setting all sections of switch SW8
G, Oct-95	<ul style="list-style-type: none"> • Corrected minor typographical errors in Sections 1 and 2 • Corrected Table 2-1, locator item K, Function • Changed Figure 5-2 and all testing target current source references from 0.2 ampere to 1.0 ampere • Changed Table 7-1 to add ECA and date data
F, Feb-95	<ul style="list-style-type: none"> • Changed all sections to reflect 200 series relay additions and relay modifications that deleted P2 and P3 jumpers and added switch SW8 • Changed Specifications, TIME and ISNT PICKUP accuracy; Output Circuits, and Isolation (Dielectric Test)
E, Sep-94	<ul style="list-style-type: none"> • Added new Figure 4-1 and bumped all following figures • Corrected old Figure 4-3, new Figure 4-4
D, May-94	<ul style="list-style-type: none"> • Changed continuous current sensing input rating and clarified TIME PICKUP and INST PICKUP specification ranges, page 1-4 • Changed Figure 1-3 to also show one ampere unit burden data • Changed time characteristics accuracy statement, page 1-7 • Added (repeated) equation for the characteristic curve time functions, page 1-9 • Changed Figure 1-5 to show one ampere unit starting data • Separated Section 4, <i>Installation</i>, into Section 4, <i>Installation</i>, and Section 5, <i>Testing</i>, and bumped all subsequent sections
C, Jun-93	<ul style="list-style-type: none"> • Added column for CT secondary to Table 1-1 and UL Recognition and CSA Certification to specifications • Page 3-2: Deleted “or reset” from last sentence in paragraph Outputs. Changed from “The targets will not operate or reset...” to “The targets will not operate...” • Page 4-1: Corrected dielectric test leakage current per terminal • Page 4-3: Added BE1-50/51M, vertical model rear view to Figure 4-3

Manual Revision and Date	Change
B, Sep-92	<ul style="list-style-type: none"> • Page 1-1: Application, deleted reference to dust tight cover • Page 1-4: Specifications, TIME Dropout to not less than 95% of pickup value • Page 1-7: Specifications, Time Reset, added statement to ensure sufficient power to power-up relay when using decaying characteristic • Page 1-8: Specifications, corrected Storage Range Temperature degrees F • Page 1-9: Defined British Standard curve types • Page 2-1: INST and TIME PICKUP selectors, added statement that changing selectors while relay is in service may cause tripping • Page 4-7: Time Pickup Test, Step 1, changed 0.45 A to 0.485 A • Page 4-9: Time Pickup Test, Step 1, changed 0.09 A to 0.096 A • Page 4-11: Added paragraph SETTING THE RELAY • Added Section 6
A, May-92	<ul style="list-style-type: none"> • Changed manual title to BE1-50/51M and incorporated engineering changes accordingly
—, Apr-92	<ul style="list-style-type: none"> • Initial release



Contents

Introduction.....	1-1
Controls and Indicators	2-1
Functional Description.....	3-1
Installation	4-1
Testing.....	5-1
Specifications	6-1
Relay Differences	7-1
Time Characteristic Curves.....	8-1



1 • Introduction

BE1-50/51M overcurrent relays are microprocessor-based, non-directional phase or ground relays that monitor the magnitude of a single-phase ac current to provide accurate instantaneous and time overcurrent protection for 50 or 60 Hz power systems. Models are available with fifteen popular time characteristics and a wide range of pickup settings.

Features

A wide range of pickup settings and front panel selectable time characteristics permit applications involving coordination with fuses, reclosers, cold load pickup, motor starting, and fixed time requirements. Also, an integrating reset function is available to simulate the disk reset of electromechanical relays.

BE1-50/51M overcurrent relays have the following standard features:

- Independent time and instantaneous elements
- A secure method to manually trip the breaker at the relay front panel
- Direct reading front panel controls
- Minimum pickup setting for safety during installation
- Time characteristics extend to a pickup multiple of 40
- Rugged draw-out construction with steel case
- Gravity-latching targets retain indication without power
- Built-in accuracy eliminates internal adjustments
- Minimum transient overreach
- Field-selectable characteristic curve selection
- Field-selectable instantaneous or integrating reset
- Field-selectable 50- or 60-Hz operation
- Field-selectable fixed instantaneous delay (0.0, 0.1, 0.2, or 0.3 second on 100 series relays and 0.0 or 0.1 second on 200 series relays.).

Individual models are available for 1-ampere and 5-ampere sensing input currents. BE1-50/51M overcurrent relays (both horizontal and vertical mounts) must be removed from the case and installed on a test bench for testing. Shorting contacts are provided for all current inputs when the relay chassis is removed from the relay case. Figure 1-1 shows the front panel of the BE1-50/51M overcurrent relay, in a C1 horizontal mount case. Figure 1-2 shows the front panel of the BE1-50/51M overcurrent relay, in a C1 vertical mount case. Internally (in terms of circuits), all relay models are the same and use the same circuit assemblies.

Advantages

BE1-50/51M overcurrent relays have many advantages over other overcurrent relays. The primary advantages are:

- Time characteristics are defined by equations and graphs
- Field-selectable time characteristics
- Very low burden extends the linear range of the CTs
- Self-powered from the sensed current
- Continuous automatic calibration

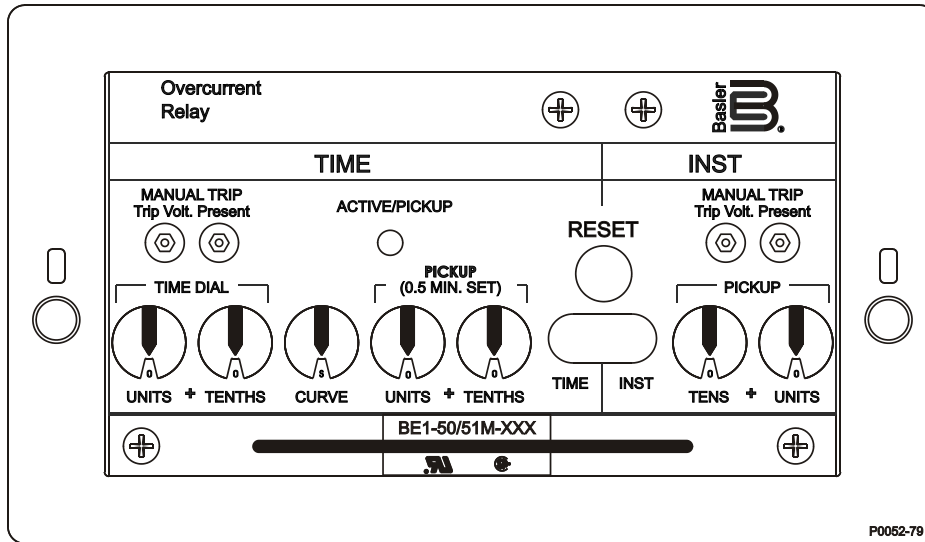

Figure 1-1. BE1-50/51M, C1 Horizontal Mount Case

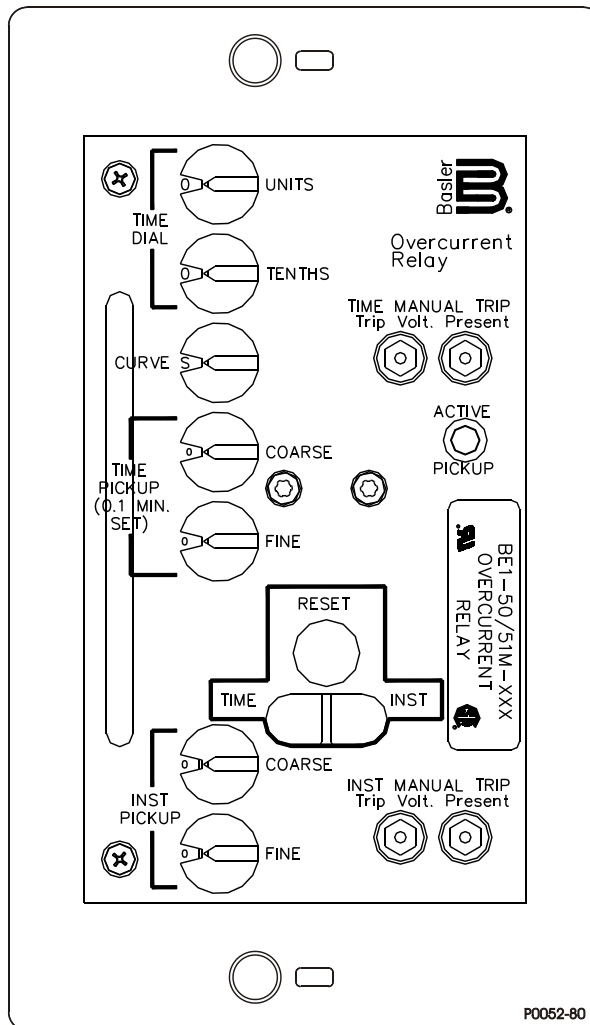

Figure 1-2. BE1-50/51M, C1 Vertical Mount Case

Model Numbers

Model number variations in the BE1-50/51M overcurrent relays are specified by a three-digit extension to the model number. Table 1-1 and Table 1-2 provide model number, case style, switch SW3-3 selections, and sensing current input ranges. Internal switches provide for selecting system-operating frequencies of 50 or 60 Hz, instantaneous element delays, curve sets, and instantaneous or integrating reset characteristics. The location and description of these switches is provided in the *Controls and Indicators* chapter. Integrating reset is available in 100 series relays (e.g. - BE1-50/51M-100) when there is adequate input current to power the relay. Integrating reset is available in 200 series relays (e.g. - BE1-50/51M-200) even when the input current falls to zero. Two hundred series relays also have additional characteristic curves available through curve set selection.

Table 1-1. BE1-50/51M Overcurrent Relays, One Ampere CT Secondary, 50/60 Hz

Model Number	Case Style	SW3-3 Selects	Sensing Input Range (Amps)	
			TIME	INST
BE1-50/51M-100	C1 (Horizontal Mount)	0.2 Second Delay	0.1 - 3.18	0.2 - 19.8
BE1-50/51M-200	C1 (Horizontal Mount)	Curve Set	0.1 - 3.18	0.2 - 19.8
BE1-50/51M-108	C1 (Vertical Mount)	0.2 Second Delay	0.1 - 3.18	0.2 - 19.8
BE1-50/51M-208	C1 (Vertical Mount)	Curve Set	0.1 - 3.18	0.2 - 19.8

Table 1-2. BE1-50/51M Overcurrent Relays, Five Ampere CT Secondary, 50/60 Hz

Model Number	Case Style	SW3-3 Selects	Sensing Input Range (Amps)	
			TIME	INST
BE1-50/51M-104	C1 (Horizontal Mount)	0.2 Second Delay	0.5 - 15.9	1.0 - 99.0
BE1-50/51M-204	C1 (Horizontal Mount)	Curve Set	0.5 - 15.9	1.0 - 99.0
BE1-50/51M-109	C1 (Vertical Mount)	0.2 Second Delay	0.5 - 15.9	1.0 - 99.0
BE1-50/51M-209	C1 (Vertical Mount)	Curve Set	0.5 - 15.9	1.0 - 99.0

NOTE: 100 series relays (e.g. - BE1-50/51M-104) have the integrating reset function when there is adequate input current to power the relay. 200 series relays (e.g. - BE1-50/51M-204) have the integrating reset function even when the input current falls to zero.



2 • Controls and Indicators

Figure 2-1 illustrates the front panel controls and indicators of the BE1-50/51M. Figure 2-2 illustrates the location of switch SW3. Both illustrations have lettered call-outs that correspond to the control and indicator descriptions provided in Table 2-1.

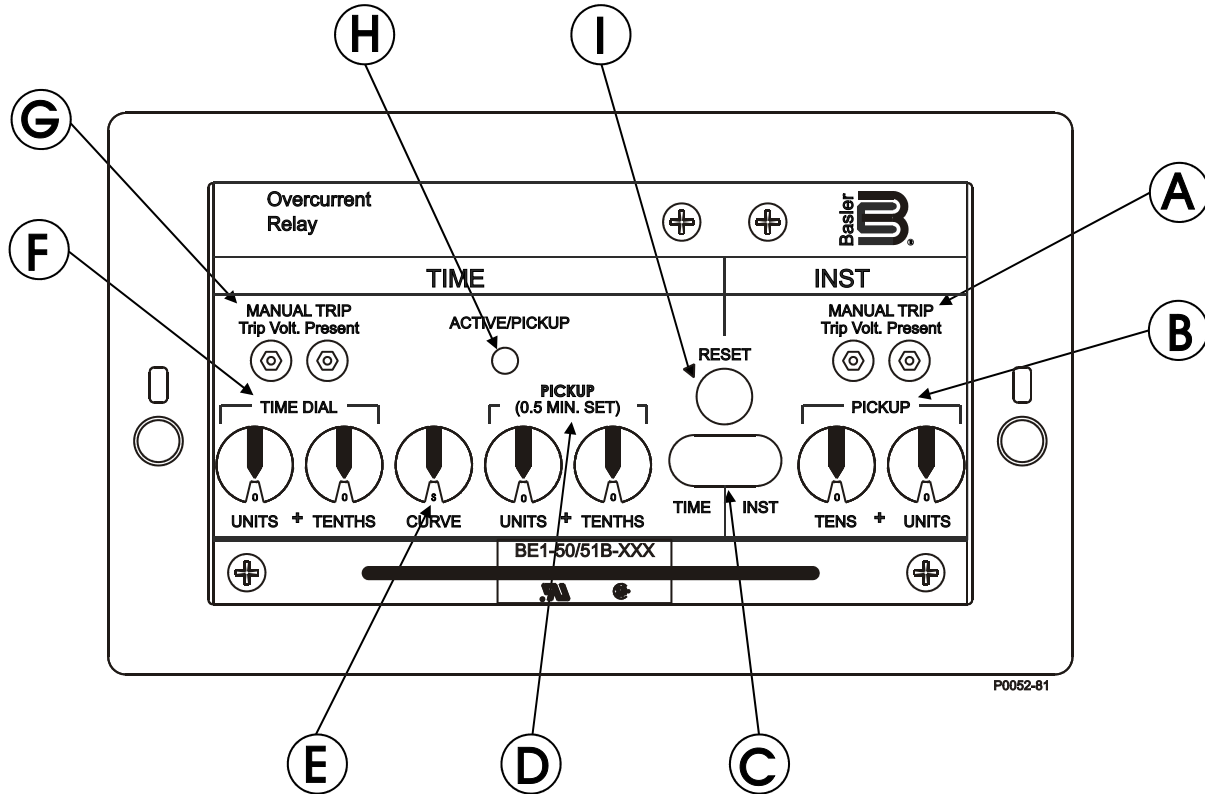

Figure 2-1. Location of Controls and Indicators

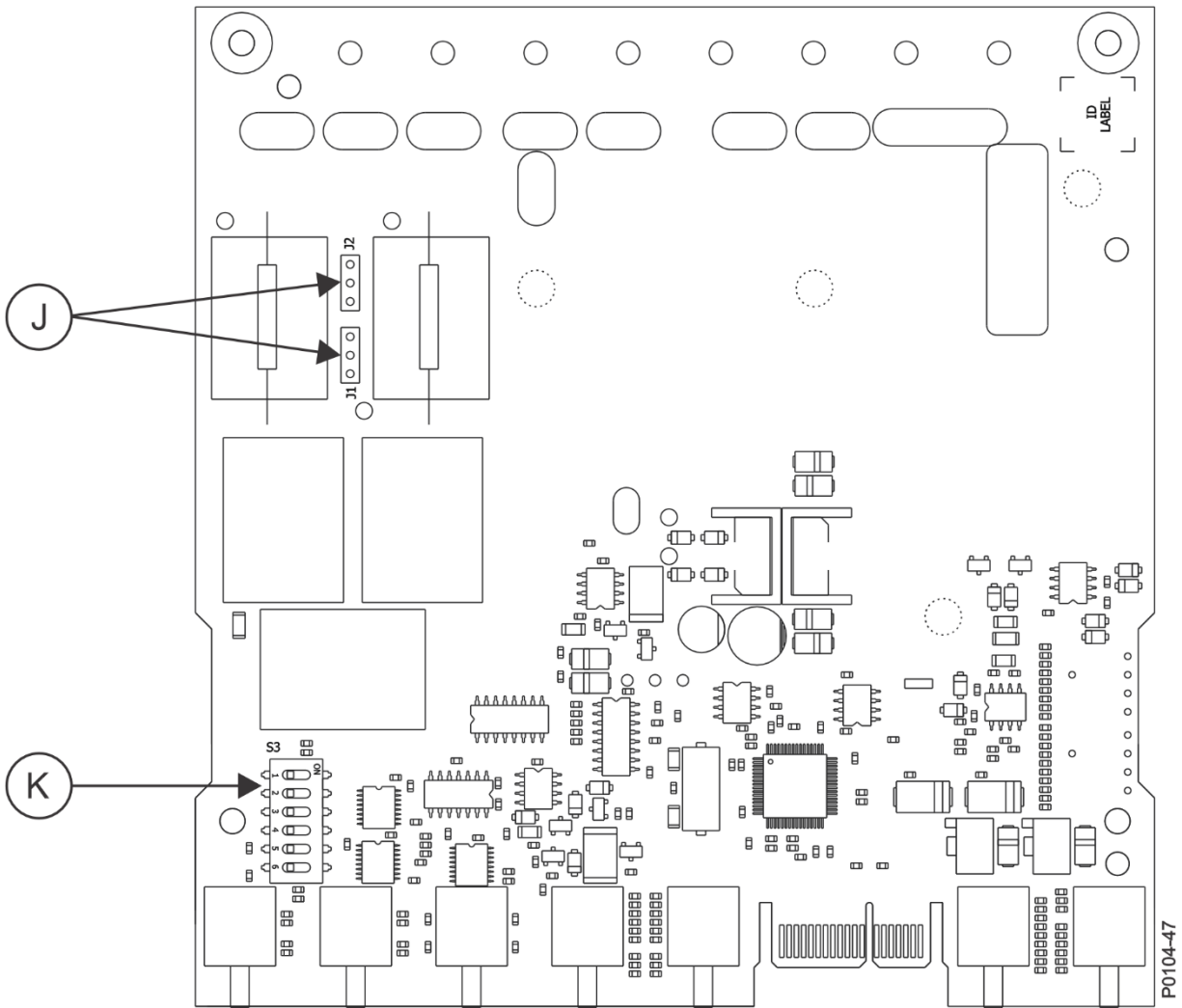

Figure 2-2. Location of Jumpers and Switch

Table 2-1. BE1-50/51M Controls and Indicators (Refer to Figure 2-1 and Figure 2-2)

Locator	Control or Indicator	Function
A	INST MANUAL TRIP Test Points	When shorted, the test points (jacks) provide a secure means to manually trip the controlled breaker. Jacks accept a standard 0.08-inch diameter phone tip plug.
B	INST PICKUP Selectors	Two switches (TENS and UNITS on five-ampere models, COARSE and FINE on one-ampere models) to select pickup current in amperes. Changing switch selectors while the relay is in service may cause tripping.
C	Targets	Red target indicators latch when the trip circuit current is greater than 0.2 amperes. One target each for TIME and INST.
D	TIME PICKUP Selectors	Two switches (TENS and UNITS on five-ampere models, COARSE and FINE on one-ampere models) to select pickup current in amperes. Changing switch selectors while the relay is in service may cause tripping.
E	CURVE Selector	Ten-position selector switch to select one of nine inverse functions or one fixed time function.
F	TIME DIAL Selectors	Two selector switches (UNITS and TENTHS) to select the desired characteristic curve. A setting of 0.0 results in instantaneous operation without any intentional delay. A setting of 9.9 corresponds to the typical time provided by an electromechanical relay at its maximum dial setting.
G	TIME MANUAL TRIP Test Points	When shorted, the test points provide a secure means to manually trip the controlled breaker. Jacks accept a standard 0.08-inch diameter phone tip plug.
H	ACTIVE/PICKUP LED	This bicolor LED indicates the level of current sensed by the relay. A green LED indicates that the relay is active but not picked up. The LED changes to red when the sensed current exceeds the time overcurrent pickup setting and back to green when the sensed current decreases below 95% of the time overcurrent pickup setting. Note: A minimum of 0.5 A (5A units) or 0.1 A (1A units) is required to light the LED. The LED may not turn green (active) before turning red (picked up) at the 0.5 A pickup setting on 5A units or 0.1 A pickup setting on 1A units.
I	Target RESET Button	Linkage extends through back of front cover to reset both gravity-latched target indicators.
J	Target Operating Current Jumpers	Two user-adjustable jumpers control the range of trip circuit current required to operate the time overcurrent (51) and instantaneous overcurrent (50) target indicators. Jumper J1 sets the minimum current range for the 51 target indicator, and J2 sets the minimum current range for the 50 target indicator. Two jumper positions are possible: across pins 1 and 2 or across pins 2 and 3. Installing a jumper across pins 1 and 2 gives a minimum operating current of 0.9 to 2.25 A. Installing a jumper across pins 2 and 3 gives a minimum operating current of 80 to 200 mA.
K	SW3-1	SW3-1 selects the system operating frequency. Opening SW3-1 (OFF) selects 60-hertz operation. Closing SW3-1 (ON) selects 50-hertz operation.
	SW3-2	SW3-2 selects additional delay for the instantaneous element. Closing SW3-2 (ON) provides an additional instantaneous delay of 0.1 seconds.

Locator	Control or Indicator	Function
	SW3-3	<p><u>100 Series Relays</u> Closing SW3-3 (ON) provides an additional instantaneous delay of 0.2 seconds. Closing both SW3-2 (ON) and SW3-3 (ON) provides an additional instantaneous delay of 0.3 seconds.</p> <p><u>200 Series Relays</u> Opening SW3-3 (OFF) selects ABB type curves. Closing SW3-3 (ON) selects GE IAC type curves.</p>
	SW3-4	SW3-4 provides selection of either instantaneous or integrating reset characteristics. Closing SW3-4 (ON) selects integrating reset characteristics. Opening SW3-4 (OFF) selects instantaneous reset characteristics. See the <i>Specifications</i> chapter for details on time reset.
	SW3-5	Closing SW3-5 (ON) configures the auxiliary output contact to close with the instantaneous (50) trip. If SW3-5 and SW3-6 are both closed (ON), the auxiliary output contact will close with either the 50 or 51 trip.
	SW3-6	Closing SW3-6 (ON) configures the auxiliary output contact to close with the timed (51) trip. If SW3-5 and SW3-6 are both closed (ON), the auxiliary output contact will close with either the 50 or 51 trip.
K	Auxiliary Output Jumper Terminations	<p>Configures the auxiliary output contacts to close with either the instantaneous (50) trip and/or the timed (51) trip.</p> <p>Jumper E2 to E1A to close the auxiliary contact with the timed (51) trip. This jumper is yellow and factory-installed to close the auxiliary output contacts with the timed trip.</p> <p>Jumper E3 to E1B to close the auxiliary contact with the instantaneous (50) trip. This jumper is blue and factory-installed to close the auxiliary output contacts with the instantaneous trip.</p> <p>Users with BE1-50/51M unit revisions Q, R, and S in 100 series relays and unit revisions H and previous in 200 series relays, refer to the <i>Relay Differences</i> chapter for the location of the auxiliary output jumper terminations and the location of SW3. (Note: In all previous revisions, the reference designator for SW3 was SW8.)</p>

Relay Differences

Users with a relay purchased before fall 2024, refer to the *Relay Differences* chapter for the location of the auxiliary output jumper terminations and the location of SW3.

3 • Functional Description

BE1-50/51M Overcurrent Relays are microprocessor-based non-directional relays that measure ac current to provide secure and reliable instantaneous and time overcurrent protection for power systems.

Sensing Input

Single-phase ac current from system current transformers (CT) is brought into the overcurrent relay at terminals 8 and 9. Refer to Figure 3-1 to follow the functional description. The input current is applied to internal power and signal CTs.

Power Supply

Current from the power CT is rectified, filtered, and supplied to all relay internal circuitry for operating power. A precision +5 Vdc supply also serves as a reference for automatic calibration.

Instantaneous Signal

Current from the signal CT is rectified and applied to the instantaneous scaling resistors controlled by the INST PICKUP selector switches. The analog voltage of the instantaneous input signal developed across the scaling resistors is filtered and applied to the multiplexor (MUX).

Time Signal

Current from the signal CT is also rectified and applied to the time scaling resistors controlled by the TIME PICKUP selector switches. The analog voltage of the time input signal is also filtered and applied to the multiplexor.

Microprocessor

Operating power from the power supply is applied to the microprocessor supervisor circuit. When the microprocessor is active and executing code, the ACTIVE/PICKUP LED is green. When the input current falls below an acceptable level, the supervisor circuit interrupts the microprocessor, halts further operation, and turns OFF the ACTIVE/PICKUP LED. A microprocessor watchdog feature resets the microprocessor program when the program flow is interrupted.

Information from the TIME DIAL selector switches, the TIME CURVE selector switch, INST DELAY switches, and RESET CHAR switch is also applied to the microprocessor. The microprocessor uses these inputs to set the operating parameters.

When the microprocessor is ready for analog information from the multiplexor, microprocessor control signals cause the multiplexor to route the desired input through to the output. The output is converted from an analog value to a digital value and applied to the microprocessor.

The microprocessor performs the program operations based on the inputs and the internal software program. When the sensed current exceeds the TIME PICKUP setting, the ACTIVE/PICKUP LED turns from green to red. The TIME (51) contact is closed in accordance with the TIME characteristic equation. If the sensed current exceeds the INST PICKUP setting, the INST contact (50) is closed.

Power-Off Sensing

In 200 series relays, power-off sensing circuits measure the decaying voltage to determine the length of time that power is removed (zero current). This provides information for the integrating reset function even when power has been entirely removed.

Outputs

Instantaneous and Timed

System circuit breakers controlled by the output contacts can be manually tripped by applying a short across the TIME or INST MANUAL TRIP front panel test points. Current flow in the trip circuit is indicated by the operation of the target. The targets will not operate without adequate operating power for the relay.

Warning!

Trip circuit voltage is present at the front panel test points. When shorting the test points, use insulated jumpers to avoid contact with these voltages.

Auxiliary

The auxiliary output contacts can be configured by the user to close when the timed and/or instantaneous trip occurs. With SW3-5 and SW3-6 ON (this is the factory setting) either the timed or instantaneous trip closes the auxiliary contacts.

Relay Differences

Users with a relay purchased before fall 2024, refer to the *Relay Differences* chapter for the location of the auxiliary output jumper terminations and the location of SW3.

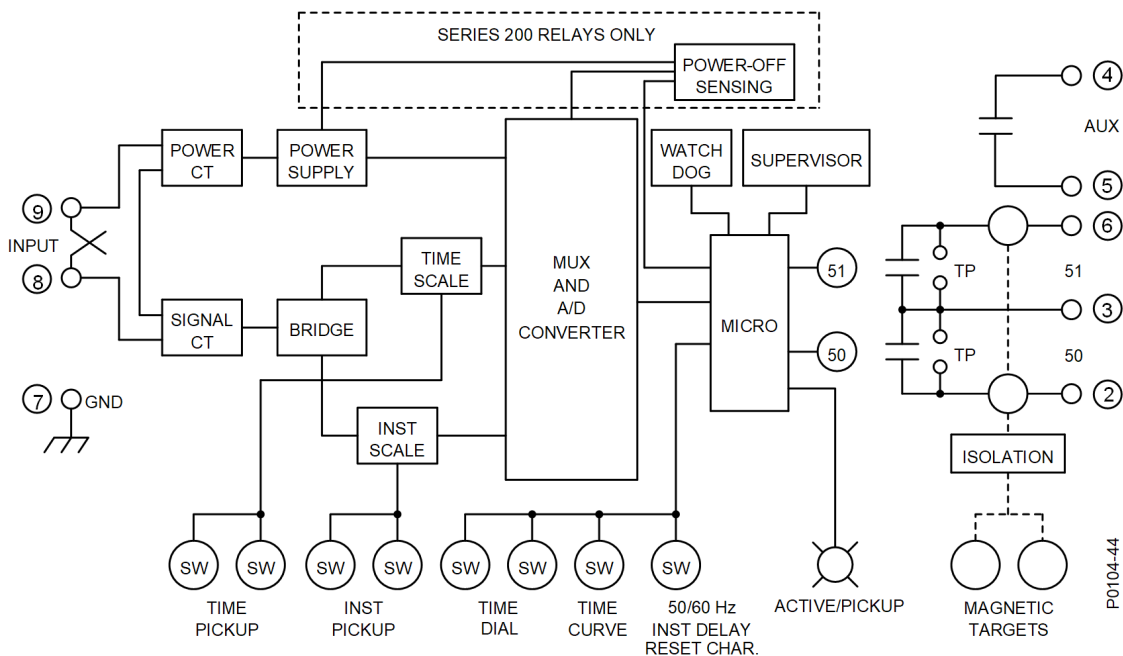

Figure 3-1. Functional Block Diagram

Target Indicators

Gravity-latched, manually-reset, current-operated target indicators are provided for the time overcurrent (51) trip output and the instantaneous overcurrent A (50) trip output. The level of trip circuit current required to operate each target is individually controlled by a circuit board jumper. The minimum operating current range can be set for 80 to 200 milliamperes or 0.9 to 2.25 amperes. See Section 2, *Controls and Indicators* for jumper locations and function assignments.

4 • Installation

When not shipped as part of a control or switchgear panel, the relays are shipped in sturdy cartons to prevent damage during transit. Immediately upon receipt of a relay, check the model and part number against the requisition and packing list to see that they agree. Visually inspect the relay for damage that may have occurred during shipment. If there is evidence of damage, immediately file a claim with the carrier and notify the Regional Sales Office, or contact the Sales Representative at Basler Electric, Highland, Illinois.

Proper operation of the relay may be confirmed by performing the operational test procedure in the *Testing* chapter. If the relay won't be installed immediately, store the relay in its original shipping carton in a moisture and dust-free environment.

Mounting

A rack mounting plate (part number 9252012001) can be purchased to mount four BE1-50/51M (vertical mount) relays side-by-side in a standard 19-inch-wide rack. The rack mounting plate is four rack units (seven inches) high and is shown in Figure 4-1. A cover (part number 9252012101) is also available that covers one mounting location. Relay outline dimensions and panel drilling diagrams are shown in Figure 4-2 and Figure 4-3.

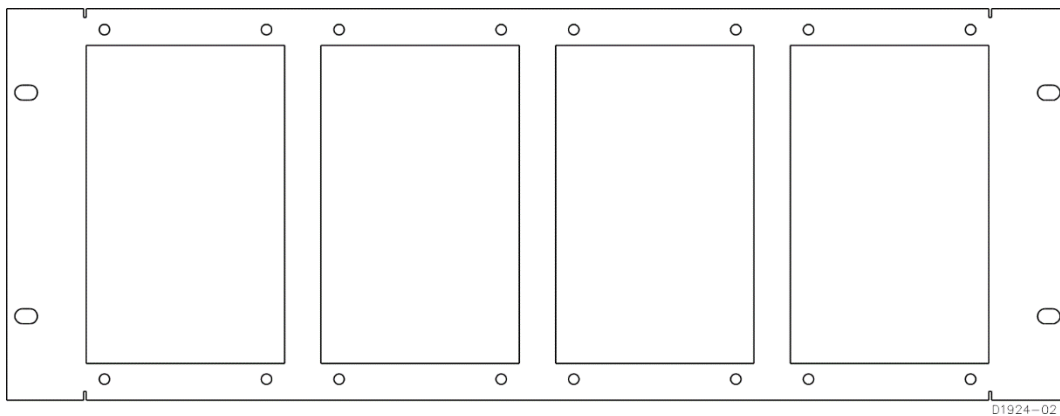

Figure 4-1. Rack Mounting Plate, Part Number 9252012001

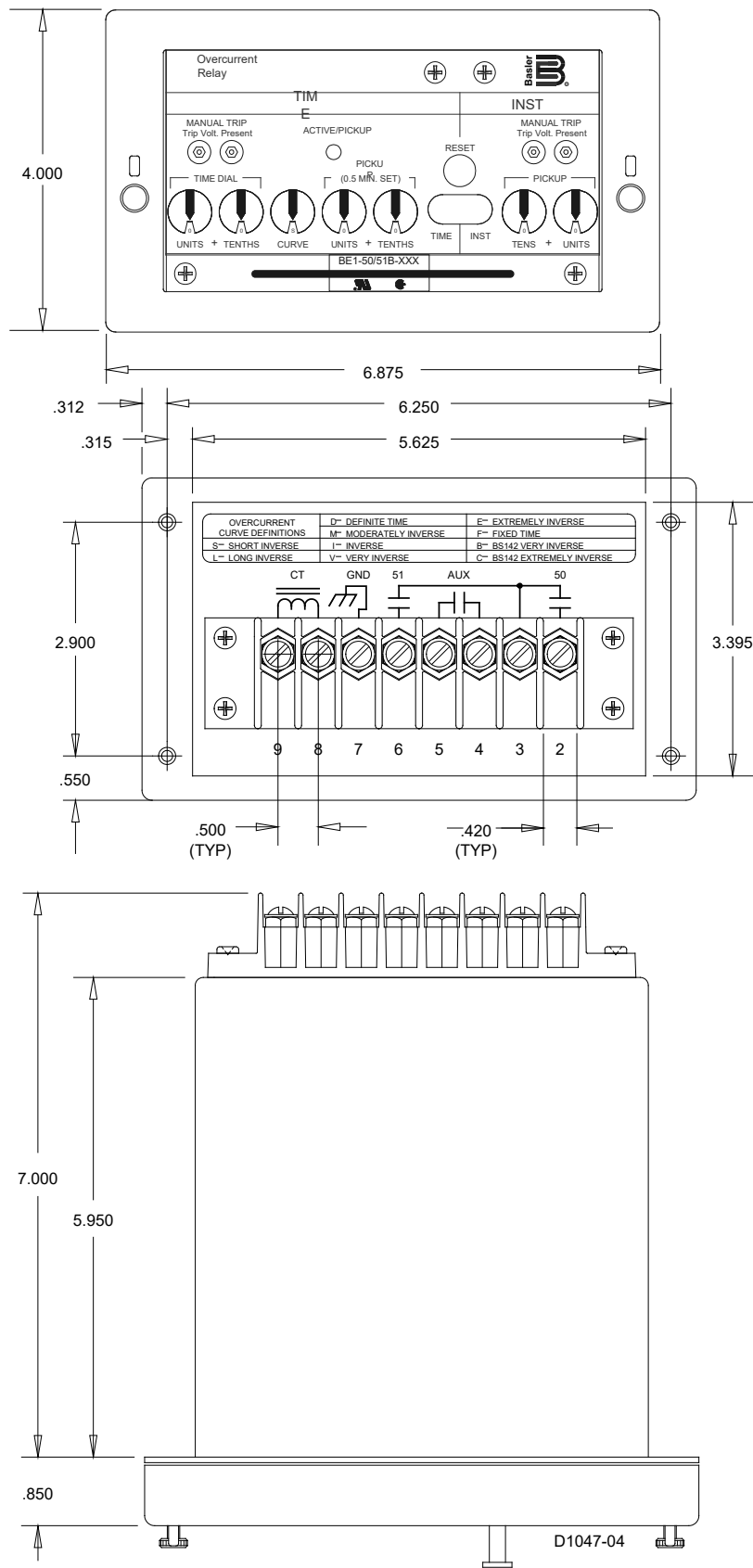

Figure 4-2. Outline Dimensions

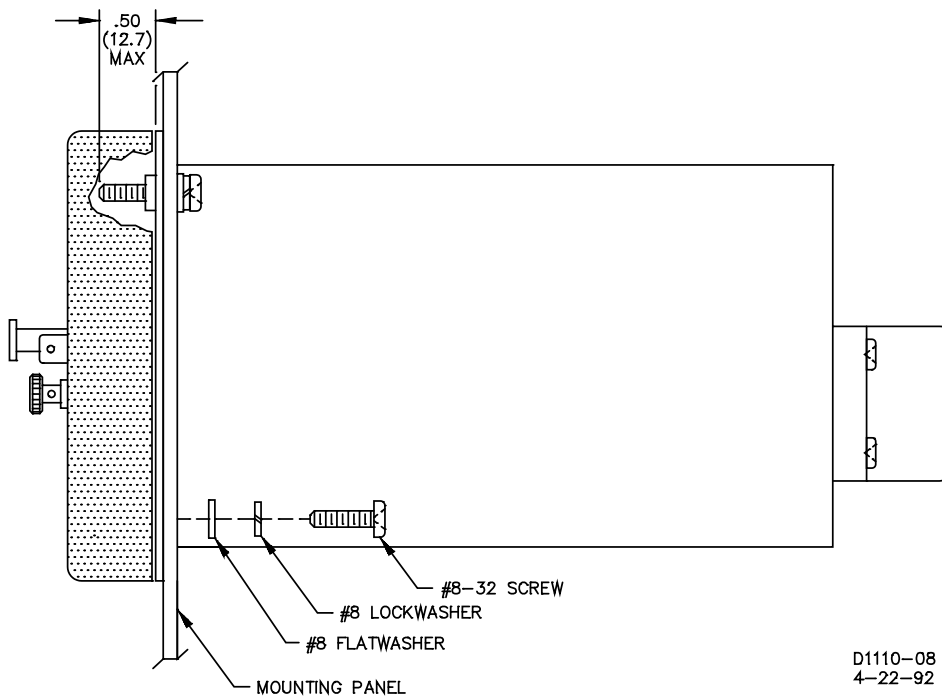
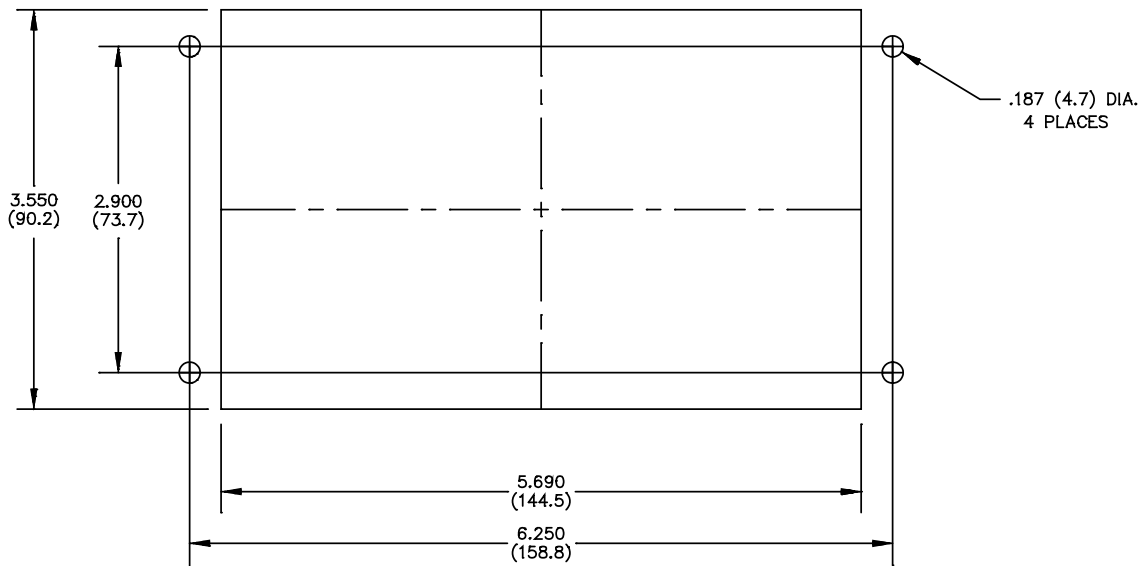

Figure 4-3. Panel Drilling Diagram, C1 Case

Connections

Incorrect wiring may result in damage to the relay. Be sure to check model and part number before connecting and energizing a particular relay.

Notes

Be sure that the relay is hard-wired to earth ground with no smaller than 12 AWG copper wire attached to the ground terminal on the rear of the unit case. When the relay is configured in a system with other devices, it is recommended to use a separate lead to the ground bus from each unit.

It is recommended in all applications where contact outputs drive relay coils that a reverse biased diode be implemented in parallel with the relay coil for EMI suppression.

Connections should be made with minimum wire size of 14 AWG except as noted for the ground wire. Typical ac input and dc control connections are shown in Figure 4-4 and Figure 4-5. Relay internal connections are shown on the back of the relay. Figure 4-6 shows a rear view of the relay and the connections.

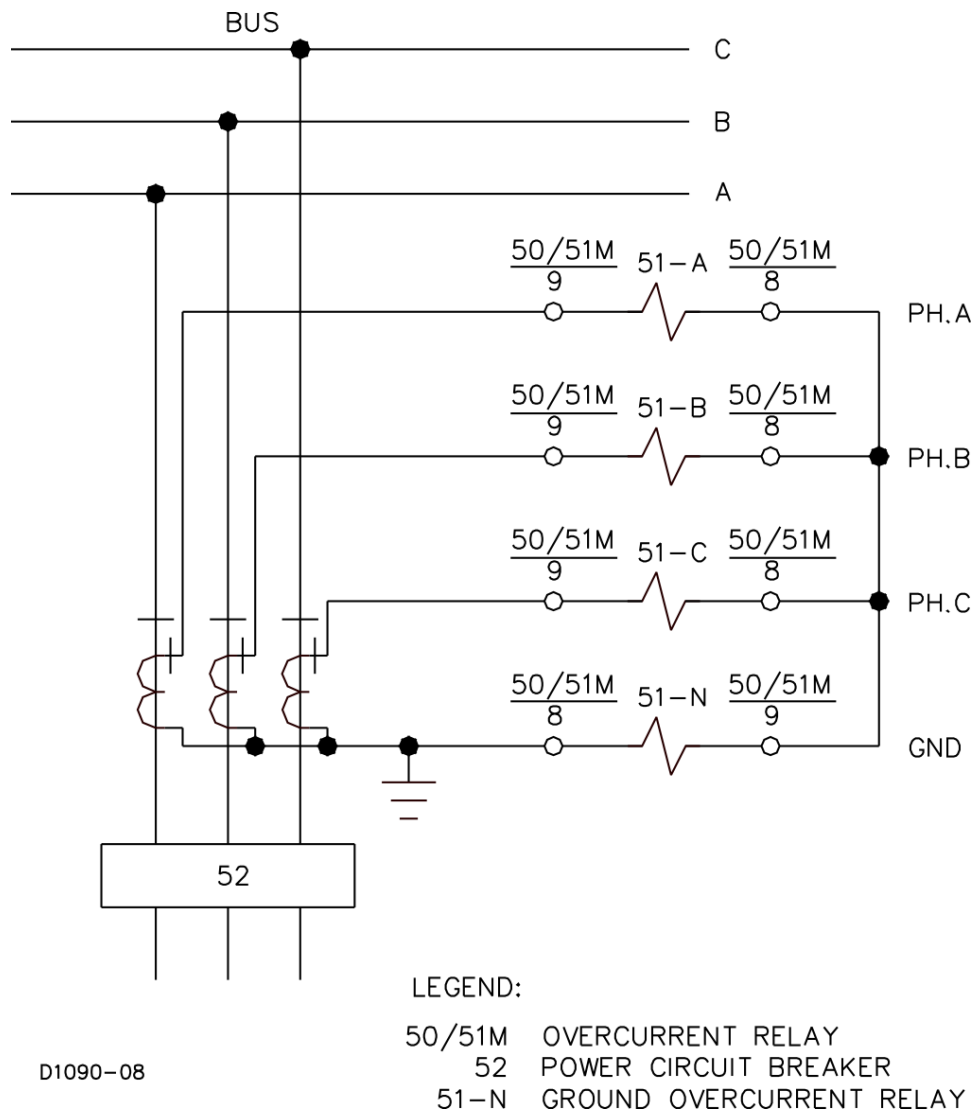

Figure 4-4. AC Input Connections

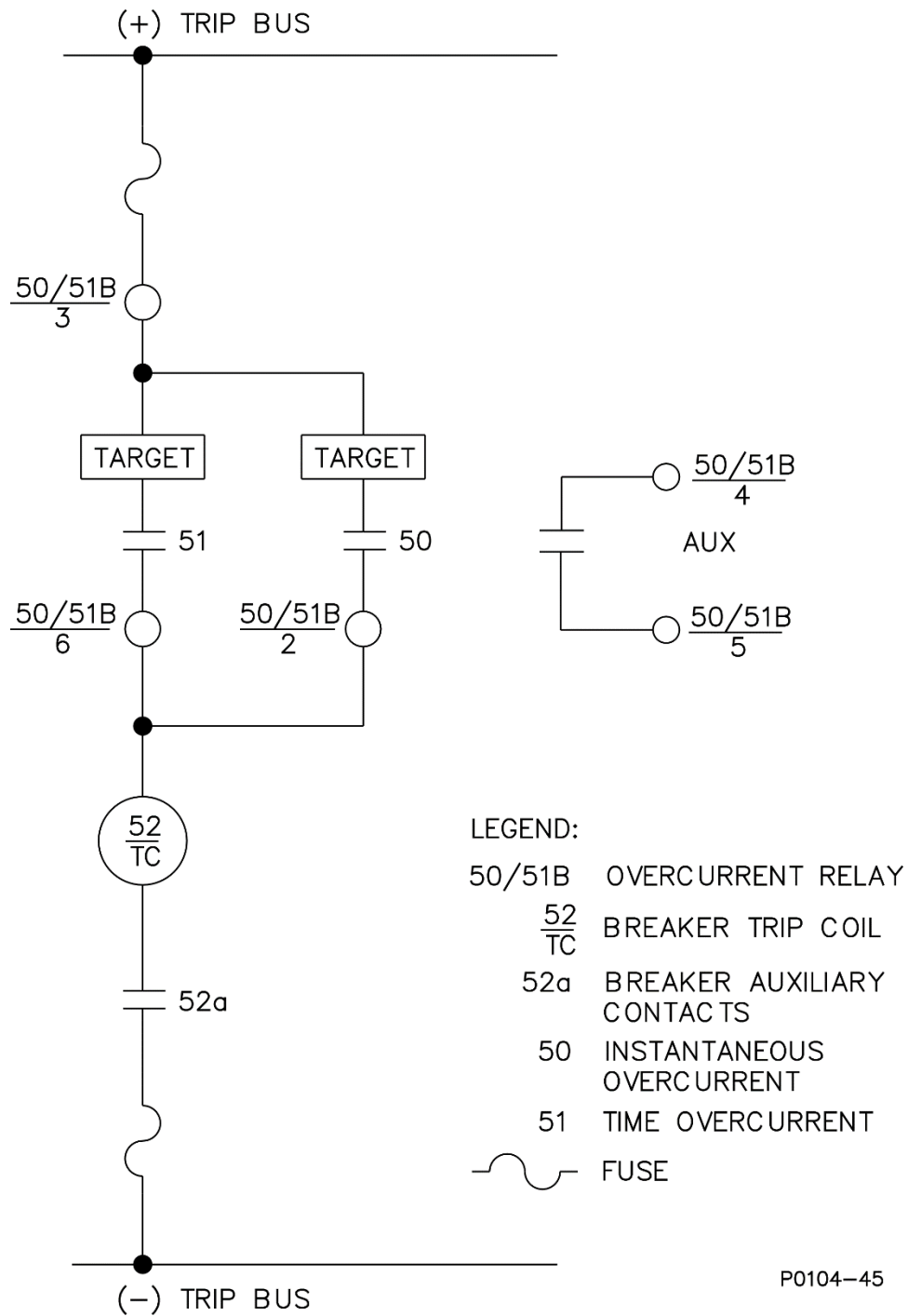
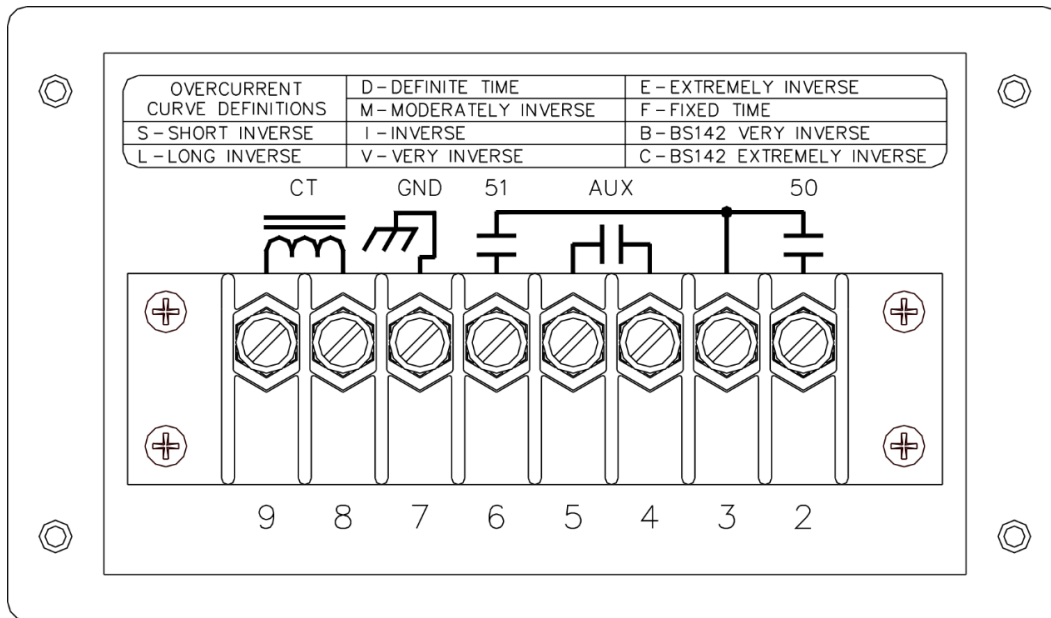
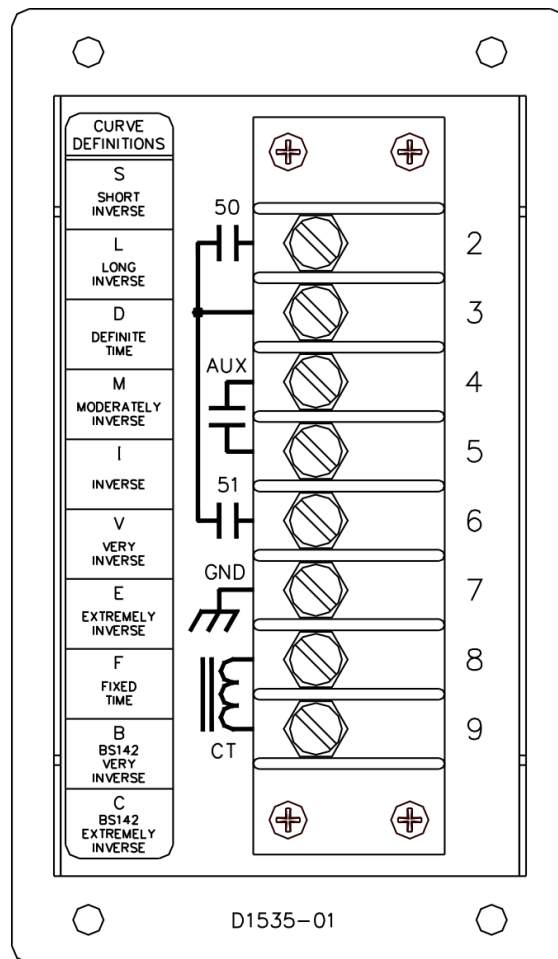

Figure 4-5. DC Control Connections



D1047-06



D1535-01

Figure 4-6. BE1-50/51M Terminal Connections, Rear View

Maintenance

BE1-50/51M overcurrent relays require no preventive maintenance. However, periodic checks should be performed according to scheduled practices. A recommended periodic test is provided in the *Testing* chapter. If the relay fails to function properly, contact the Technical Sales Support Department of Basler Electric.

Storage

This device contains long-life aluminum electrolytic capacitors. For devices that are not in service (spares in storage), the life of these capacitors can be maximized by energizing the device for 30 minutes once per year.



5 • Testing

Dielectric testing, operational testing, and periodic testing are described in the following paragraphs.

Dielectric Test

In accordance with IEC 255-5 and IEEE C37.90-2005, one-minute dielectric (high potential) tests may be performed as follows:

All circuits to ground 2,828 Vdc or 2,000 Vac.

Input to output circuits 2,828 Vdc or 2,000 Vac.

Output contacts are surge protected.

Operational Test Procedure

The following procedures verify operation of BE1-50/51M relays. The test setups of Figure 5-1 and Figure 5-2 are intended primarily as an illustration of the principles involved. Other test setups known to be capable of testing with the stated and implied tolerances (including equipment specifically designed for testing relays) may be used.

Test Equipment Required

- Current source with a range from 0 to 20 Aac (sensing input current)
- AC or DC power source (target operation)
- Timer or counter

Caution

When testing units with integrating reset characteristics selected, timing may be affected by the integrating reset.

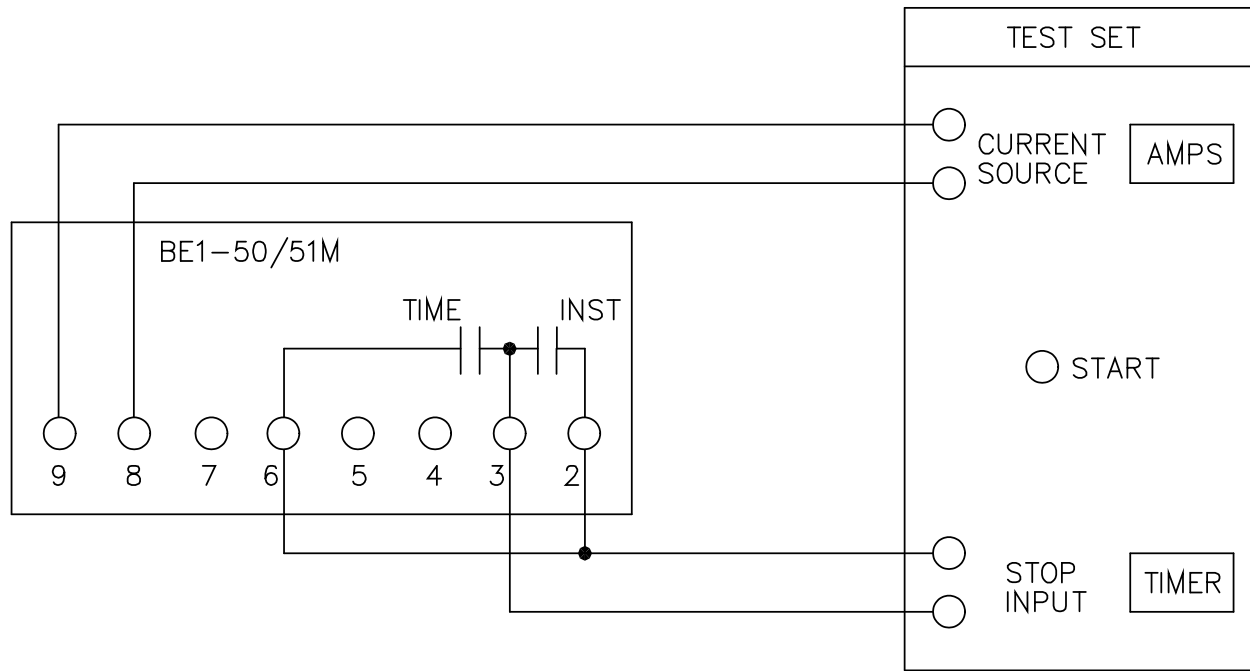

D1145-03

Figure 5-1. Pickup and Timing Test Setup

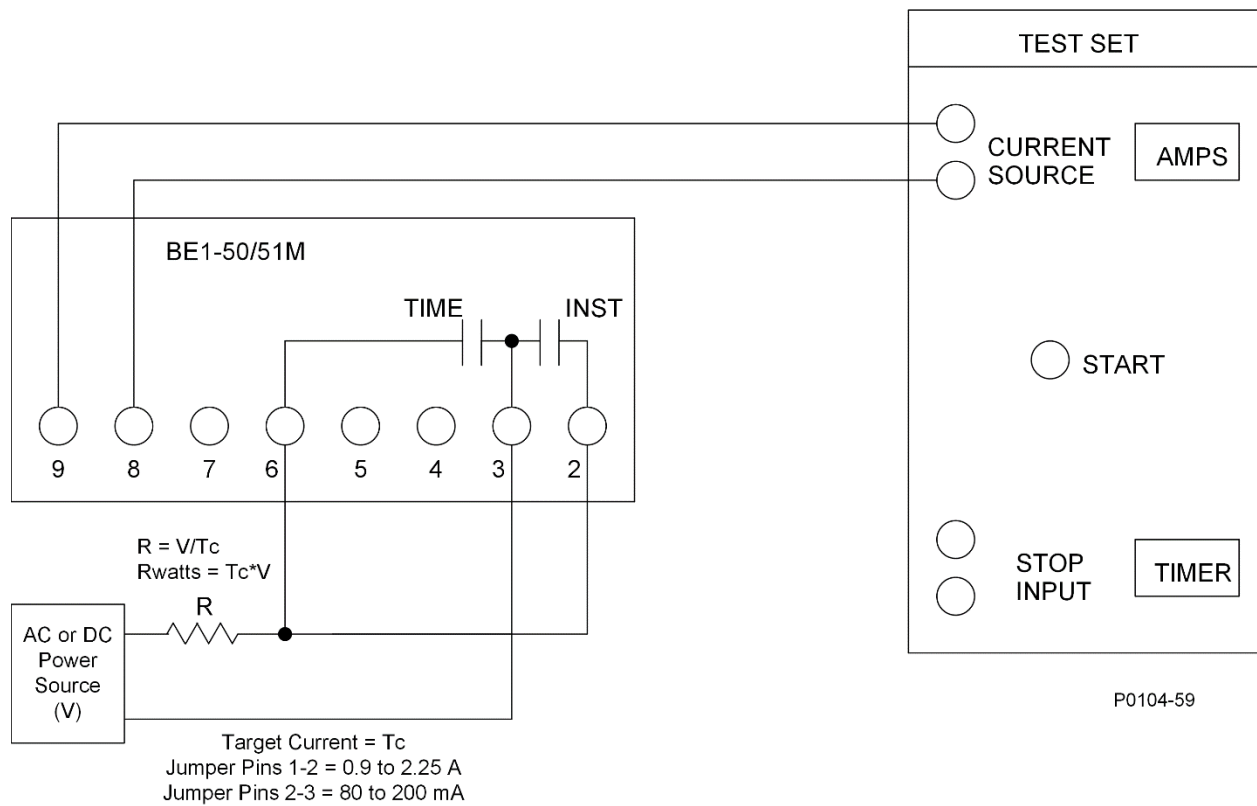

P0104-59

Figure 5-2. Target Operational Test Setup

Note

When testing TIME overcurrent functions, INST PICKUP settings of 00 will affect the calibration of the TIME functions. TIME PICKUP settings of 00 also affect INST functions.

Test Procedure for Five-Ampere Units**TIME Pickup Test**

Perform preliminary setup:

- Connect test setup as shown in Figure 5-1.
- Ensure that SW3 switches are set correctly: SW3-1 for operating frequency, SW3-2 to OFF (no instantaneous delay), SW3-3 to OFF (no instantaneous delay [100 series relays] or ABB type curves selected [200 series relays]), and SW3-4 to OFF (selects instantaneous reset).
- Set TIME DIAL to 0.0.
- Set CURVE to S.
- Set TIME PICKUP to 0.5.
- Set INST PICKUP to 90.

Step 1. Slowly increase current to terminals 8 and 9. ACTIVE/PICKUP LED should turn RED at a maximum input current of 0.550 ampere.

Step 2. Decrease input current until ACTIVE/PICKUP LED turns GREEN then OFF.

Step 3. Set TIME PICKUP to 2.2.

Step 4. Slowly increase current to terminals 8 and 9. ACTIVE/PICKUP LED should change from GREEN to RED at an input current of 2.131 to 2.269 amperes.

Step 5. Decrease input current until ACTIVE/PICKUP LED turns GREEN then OFF.

INST Pickup Test

Perform preliminary setup:

- Connect test setup as shown in Figure 5-1.
- Ensure that SW3 switches are set correctly: SW3-1 for operating frequency, SW3-2 to OFF (no instantaneous delay), SW3-3 to OFF (no instantaneous delay [100 series relays] or ABB type curves selected [200 series relays]), and SW3-4 to OFF (selects instantaneous reset).
- Set TIME DIAL to 0.0.
- Set CURVE to S.
- Set TIME PICKUP to 15.1.
- Set INST PICKUP to 01.

Step 1. Slowly increase current to terminals 8 and 9. INST contacts should close at an input current of 0.955 to 1.045 amperes.

Step 2. Decrease input current until INST output contacts open.

Step 3. Set INST PICKUP to 08.

Step 4. Slowly increase current to terminals 8 and 9. INST contacts should close at an input current of 7.815 to 8.185 amperes.

Step 5. Decrease input current until INST output contacts open.

Time Dial Test

Perform preliminary setup:

- Connect test setup as shown in Figure 5-1.

- Ensure that SW3 switches are set correctly: SW3-1 for operating frequency, SW3-2 to OFF (no instantaneous delay), SW3-3 to OFF (no instantaneous delay [100 series relays] or ABB type curves selected [200 series relays]), and SW3-4 to OFF (selects instantaneous reset).
- Set TIME DIAL to 4.5.
- Set CURVE to S.
- Set TIME PICKUP to 1.0.
- Set INST PICKUP to 90.

Step 1. Prepare to apply 1.5 amperes input current to terminals 8 and 9 and record the elapsed time from when current is applied until TIME output contacts close.

Step 2. Apply the current (step from 0 to 1.5 amperes) and record the elapsed time. Elapsed time should be 1.754 to 2.084 seconds. (This tolerance is greater than $\pm 2\%$ because it is the accumulation of both pickup and timing tolerances.)

Step 3. Remove input current.

Integrating Reset Test (Applicable Only to 200 Series Relays)

Perform preliminary setup:

- Connect test setup as shown in Figure 5-1.
- Ensure that SW3 switches are set correctly: SW3-1 for operating frequency, SW3-2 to OFF (no instantaneous delay), SW3-3 to OFF (no instantaneous delay [100 series relays] or ABB type curves selected [200 series relays]), and SW3-4 to ON (selects integrating reset).
- Set TIME DIAL to 4.5.
- Set CURVE to I.
- Set TIME PICKUP to 1.0.
- Set INST PICKUP to 90.

Step 1. Set power source to provide a target current of 1.0 ampere.

Step 2. Read all of Step 3 before beginning Step 3.

Step 3. Apply 4.0 amperes input current to terminals 8 and 9. After the unit trips, remove the input current for 20 ± 0.25 seconds, then reapply the 4.0 amperes input current. Record the elapsed time from the re-application of input current to the output retrip.

Result: Elapsed time should be 1.55 ± 0.3 seconds.

Target Test

Perform preliminary setup:

- Connect test setup as shown in Figure 5-2.
- Ensure that SW3 switches are set correctly: SW3-1 for operating frequency, SW3-2 to OFF (no instantaneous delay), SW3-3 to OFF (no instantaneous delay [100 series relays] or ABB type curves selected [200 series relays]), and SW3-4 to OFF (selects instantaneous reset).
- Set TIME DIAL to 4.5.
- Set CURVE to S.
- Set TIME PICKUP to 1.0.
- Set INST PICKUP to 90.

Step 1. Apply 2 Aac to terminals 8 and 9 to trip the 51 relay output.

Step 2. Slowly increase the power source to provide target current and verify that the Time target operates at the level of current determined by the Target Operating Current Jumpers.

The Target Operating Current Jumpers are located on the circuit board and identified as J1 and J2. J1 sets the minimum current range for the 51 target, and J2 sets the minimum current range for the 50 target. A jumper installed across pins 1 and 2 gives a minimum operating current of 0.9 to 2.25 A. A jumper installed across pins 2 and 3 gives a minimum operating current of 80 to 200 mA.

- Step 3. Remove the target and sensing current and reset the target.
- Step 4. Set TIME PICKUP to 9.0 and INST PICKUP to 01.
- Step 5. Apply 2 Aac to terminals 8 and 9 to trip the 50 relay output.
- Step 6. Slowly increase the power source to provide target current and verify that the Instantaneous target operates at the level of current determined by the Target Operating Current Jumpers.
- Step 7. Remove the target and sensing current and reset the target.

Manual Trip Test

Perform preliminary setup:

- Connect test setup as shown in Figure 5-2.
- Ensure that SW3 switches are set correctly: SW3-1 for operating frequency, SW3-2 to OFF (no instantaneous delay), SW3-3 to OFF (no instantaneous delay [100 series relays] or ABB type curves selected [200 series relays]), and SW3-4 to OFF (selects instantaneous reset).
- Set TIME DIAL to 4.5.
- Set CURVE to S.
- Set TIME PICKUP to 1.0.
- Set INST PICKUP to 01.

Warning!

Trip circuit voltage is present at the front panel test points. When shorting the test points, use insulated jumpers to avoid contact with these voltages.

- Step 1. Set power source to provide a target current of 1.0 A or 100 mA according to J1 and J2 positions.
- Step 2. Apply 0.9 ampere input current to terminals 8 and 9.
- Step 3. Connect a jumper between TIME MANUAL TRIP test points. Check that TIME target operates.
- Step 4. Connect a jumper between INST MANUAL TRIP test points. Check that INST target operates.
- Step 5. Reset targets.

Test Procedure for One-Ampere Units

TIME Pickup Test

Perform preliminary setup:

- Connect test setup as shown in Figure 5-1.
- Ensure that SW3 switches are set correctly: SW3-1 for operating frequency, SW3-2 to OFF (no instantaneous delay), SW3-3 to OFF (no instantaneous delay [100 series relays] or ABB type curves selected [200 series relays]), and SW3-4 to OFF (selects instantaneous reset).
- Set TIME DIAL to 0.0.
- Set CURVE to S.
- Set TIME PICKUP to 0.1.
- Set INST PICKUP to 18.0.

- Step 1. Slowly increase current to terminals 8 and 9. ACTIVE/PICKUP LED should turn RED at a maximum input current of 0.11 ampere.
- Step 2. Decrease input current until ACTIVE/PICKUP LED turns GREEN then OFF.
- Step 3. Set TIME PICKUP to 0.44.
- Step 4. Slowly increase current to terminals 8 and 9. ACTIVE/PICKUP LED should change from GREEN to RED at an input current of 0.426 to 0.454 amperes.

Step 5. Decrease input current until ACTIVE/PICKUP LED turns Green then OFF.

INST Pickup Test

Perform preliminary setup:

- Connect test setup as shown in Figure 5-1.
- Ensure that SW3 switches are set correctly: SW3-1 for operating frequency, SW3-2 to OFF (no instantaneous delay), SW3-3 to OFF (no instantaneous delay [100 series relays] or ABB type curves selected [200 series relays]), and SW3-4 to OFF (selects instantaneous reset).
- Set TIME DIAL to 0.0.
- Set CURVE to S.
- Set TIME PICKUP to 3.02.
- Set INST PICKUP to 0.2.

Step 1. Slowly increase current to terminals 8 and 9. INST contacts should close at an input current of 0.191 to 0.209 amperes.

Step 2. Decrease input current until INST output contacts open.

Step 3. Set INST PICKUP to 1.6.

Step 4. Slowly increase current to terminals 8 and 9. INST contacts should close at an input current of 1.563 to 1.637 amperes.

Step 5. Decrease input current until INST output contacts open.

Time Dial Test

Perform preliminary setup:

- Connect test setup as shown in Figure 5-1.
- Ensure that SW3 switches are set correctly: SW3-1 for operating frequency, SW3-2 to OFF (no instantaneous delay), SW3-3 to OFF (no instantaneous delay [100 series relays] or ABB type curves selected [200 series relays]), and SW3-4 to OFF (selects instantaneous reset).
- Set TIME DIAL to 4.5.
- Set CURVE to S.
- Set TIME PICKUP to 0.2.
- Set INST PICKUP to 18.0.

Step 1. Prepare to apply 0.3 amperes input current to terminals 8 and 9 and record the elapsed time from when current is applied until TIME output contacts close.

Step 2. Apply the current (step from 0 to 0.3 amperes) and record the elapsed time. Elapsed time should be 1.754 to 2.084 seconds. (This tolerance is greater than $\pm 2\%$ because it is the accumulation of both pickup and timing tolerances.)

Step 3. Remove input current.

Integrating Reset Test (Applicable Only to 200 Series Relays)

Perform preliminary setup:

- Connect test setup as shown in Figure 5-1.
- Ensure that SW3 switches are set correctly: SW3-1 for operating frequency, SW3-2 to OFF (no instantaneous delay), SW3-3 to OFF (no instantaneous delay [100 series relays] or ABB type curves selected [200 series relays]), and SW3-4 to ON (selects integrating reset).
- Set TIME DIAL to 4.5.
- Set CURVE to I.
- Set TIME PICKUP to 0.2.
- Set INST PICKUP to 18.0.

Step 1. Set power source to provide a target current of 1.0 ampere.

Step 2. Read all of Step 3 before beginning Step 3.

Step 3. Apply 0.8 ampere input current to terminals 8 and 9. After the unit trips, remove the input current for 20 ± 0.25 seconds, then reapply the 0.8 ampere input current. Record the elapsed time from the re-application of input current to the output retrip.

Result: Elapsed time should be 1.55 ± 0.3 seconds.

Target Test

Perform preliminary setup:

- Connect test setup as shown in Figure 5-2.
- Ensure that SW3 switches are set correctly: SW3-1 for operating frequency, SW3-2 to OFF (no instantaneous delay), SW3-3 to OFF (no instantaneous delay [100 series relays] or ABB type curves selected [200 series relays]), and SW3-4 to OFF (selects instantaneous reset).
- Set TIME DIAL to 4.5.
- Set CURVE to S.
- Set TIME PICKUP to 0.2.
- Set INST PICKUP to 0.2.

Step 1. Apply 1 Aac to terminals 8 and 9 to trip the 51 relay output.

Step 2. Slowly increase the power source to provide target current and verify that the Time target operates at the level of current determined by the Target Operating Current Jumpers.

The Target Operating Current Jumpers are located on the circuit board and identified as J1 and J2. J1 sets the minimum current range for the 51 target, and J2 sets the minimum current range for the 50 target. A jumper installed across pins 1 and 2 gives a minimum operating current of 0.9 to 2.25 A. A jumper installed across pins 2 and 3 gives a minimum operating current of 80 to 200 mA.

Step 3. Remove the target and sensing current and reset the target.

Step 4. Set TIME PICKUP to 9.0 and INST PICKUP to 01.

Step 5. Apply 1 Aac to terminals 8 and 9 to trip the 50 relay output.

Step 6. Slowly increase the power source to provide target current and verify that the Instantaneous target operates at the level of current determined by the Target Operating Current Jumpers.

Step 7. Remove the target and sensing current and reset the target.

Manual Trip Test

Perform preliminary setup:

- Connect test setup as shown in Figure 5-2.
- Ensure that SW3 switches are set correctly: SW3-1 for operating frequency, SW3-2 to OFF (no instantaneous delay), SW3-3 to OFF (no instantaneous delay [100 series relays] or ABB type curves selected [200 series relays]), and SW3-4 to OFF (selects instantaneous reset).
- Set TIME DIAL to 4.5.
- Set CURVE to S.
- Set TIME PICKUP to 0.2.
- Set INST PICKUP to 0.2.

Warning!

Trip circuit voltage is present at the front panel test points. When shorting the test points, use insulated jumpers to avoid contact with these voltages.

Step 1. Set power source to provide a target current of 1.0 A or 100 mA according to J1 and J2 positions.

Step 2. Apply 0.15 ampere input current to terminals 8 and 9.

Step 3. Connect a jumper between TIME MANUAL TRIP test points. Check that TIME target operates.

Step 4. Connect a jumper between INST MANUAL TRIP test points. Check that INST target operates.

Step 5. Reset targets.

Setting the Relay

Select the desired relay settings before putting the relay into service. Changing pickup current settings while the relay is in service may cause tripping.

Periodic Tests

General

All relays should be tested periodically to identify and correct any problems that are found.

Single phase relays such as the BE1-50/51M are normally used in groups of four (three phase and ground) on the protected circuit. This relay scheme allows each unit to be withdrawn one at a time for testing purposes without losing protection. Only three are required at any one time to sense all types of faults on a grounded wye system. Refer to Figure 5-1 and Figure 5-2 for recommended test setups.

Periodic Test

Periodic testing should consist of the following procedures.

Step 1. Verify that the instantaneous pickup is within $\pm 2\%$ of the value set on the dials. Pickup occurs when the INST output contacts close.

Step 2. Verify that the time pickup is within $\pm 2\%$ of the value set on the dials. Pickup occurs when the LED turns GREEN then RED.

Step 3. Verify that the time to trip for the curve and time dial settings at a multiple of six is the same as the time given on the characteristic curve. Refer to the *Time Characteristic Curves* chapter for the characteristic curves.

Step 4. Verify that the time to trip for the instantaneous element at a pickup multiple of 2 is not greater than the time given on the instantaneous characteristic curve. Refer to Section 6 for the instantaneous characteristic curve.

Step 5. Verify that the targets operate with one ac ampere of trip current in the trip circuits and that they can be reset using the RESET BUTTON.

6 • Specifications

BE1-50/51M electrical and physical specifications are listed in the following paragraphs.

Operational Specifications

Time Overcurrent (51) Element

Setting the TIME PICKUP control at the minimum pickup setting (0.1 on the 1-ampere unit and 0.5 on the 5-ampere unit) places the relay in the most sensitive state and may be used as a safety setting.

1-Ampere Unit Pickup

Setting Range 0.1 to 3.18 Aac

Setting Increment 0.02 Aac

Accuracy ±2%, ±5 milliamperes at or above 0.1 ampere setting

5-Ampere Unit Pickup

Setting Range 0.5 to 15.9 Aac

Setting Increment 0.1 Aac

Accuracy ±2%, ±25 milliamperes at or above 0.5 ampere setting

Dropout

Dropout occurs at 95% of pickup value.

Timing Range

0.0 to 9.9 seconds in 0.1 second steps.

Timing Accuracy

The timing accuracy is the sum of ±1 cycle and ±2% for the range of 2 to 40 times tap and is for a given measured multiple of tap. The timing accuracy is the sum of ±2 cycles and ±2% for the range of 1.3 to 2 times tap and is for a given measured multiple of tap.

Curve Characteristics

Nine inverse time functions and one fixed time function can be selected by the front-panel Curve switch. Characteristic curves for the inverse and definite time functions are defined by the following equation.

Where:

$$T_T = \frac{AD}{M^N - C} + BD + K$$

T_T = time to trip in seconds

D = time dial setting

M = multiple of pickup setting

A, B, C, N, K = constants for the particular curve

Time characteristic curve constants are listed in Table 6-1 and Table 6-2. Constants have been selected to conform to the characteristics of electromechanical relays over a range of pickup multiples from 1.3 to 40. Values of the constants are provided for use in computer relay setting software.

**Table 6-1. Time Characteristic Curve Constants with SW3-3 Open (Off)
(Series 100 Relays or Series 200 Relays)**

Curve Type *		Figure Number †	Constants					
BE1	Similar To		A	B	C	N	K	R
S	ABB CO-2	8-1	0.2663	0.03393	1.000	1.2969	0.028	0.500
L	ABB CO-5	8-2	5.6143	2.18592	1.000	1.000	0.028	15.750
D	ABB CO-6	8-3	0.4797	0.21359	1.000	1.5625	0.028	0.875
M	ABB CO-7	8-4	0.3022	0.12840	1.000	0.5000	0.028	1.750
I	ABB CO-8	8-5	8.9341	0.17966	1.000	2.0938	0.028	9.000
V	ABB CO-9	8-6	5.4678	0.10814	1.000	2.0469	0.028	5.500
E	ABB CO-11	8-7	7.7624	0.02758	1.000	2.0938	0.028	7.750
B	BS142-B ‡	8-8	1.4636	0.00000	1.000	1.0469	0.028	3.250
C	BS142-C ‡	8-9	8.2506	0.00000	1.000	2.0469	0.028	8.000
F	None §	N/A	0.0000	1.00000	0.000	0.0000	0.000	1.000

**Table 6-2. Time Characteristic Curve Constants with SW3-3 Closed (On)
(Series 200 Relays)**

Curve Type *		Figure Number †	Constants					
BE1	Similar To		A	B	C	N	K	R
S	GE IAC 55	8-10	0.0286	0.0208	1.000	0.9844	0.028	0.0940
L	GE IAC 66	8-11	2.3955	0.00002	1.000	0.3125	0.028	7.8001
D	ABB CO-6	8-3	0.4797	0.21359	1.000	1.5625	0.028	0.8750
M	ABB CO-7	8-4	0.3022	0.12840	1.000	0.5000	0.028	1.7500
I	GE IAC 51	8-12	0.2747	0.1042	1.000	0.4375	0.028	0.8868
V	GE IAC 53	8-13	4.4309	0.0991	1.000	1.9531	0.028	5.8231
E	GE IAC 77	8-14	4.9883	0.0129	1.000	2.0469	0.028	4.7742
B	BS142-B ‡	8-8	1.4636	0.00000	1.000	1.0469	0.028	3.2500
C	BS142-C ‡	8-9	8.2506	0.00000	1.000	2.0469	0.028	8.0000
F	None §	N/A	0.0000	1.00000	0.000	0.0000	0.000	1.0000

Notes for Table 6-1 and Table 6-2:

* BE1 Curve Types:

S: Short Inverse	V: Very Inverse
L: Long Inverse	E: Extremely Inverse
D: Definite Time	B: BS142 Very Inverse
M: Moderately Inverse	C: BS142 Extremely Inverse
I: Inverse	F: Fixed Time Delay

† Figure numbers refer to the characteristic curves located in the *Time Characteristic Curves* chapter.

‡ Curves B and C are defined in British Standard BS142 and IEC Standard IEC 255-4.

§ Fixed time delay, adjustable from 0.1 to 9.9 seconds.

Integrating Reset

Reset begins when the current drops below 95% of pickup and the relay has not timed out. Switch SW3-4 provides selection of either an instantaneous or integrating reset characteristic. Opening SW3-4 forces the instantaneous reset timer to zero when timed dropout occurs. This fast reset characteristic prevents the ratcheting effect that may occur with repeating system faults. Closing SW3-4 selects the integrating reset characteristic. The integrating reset characteristic simulates the disk reset of electromechanical

relays. When the integrating reset characteristic is selected on 100 series relays, ensure that sufficient input power is available to power up the relay. This is not required on series 200 relays. Series 200 relays provide the integrating reset function even when input current falls to zero.

Integrating reset characteristics are defined by the following equation and shown in Figure 6-1. Equation constants are provided in Table 6-1 and Table 6-2.

Integrating Reset Equation:

$$T_R = \frac{RD}{M^2 - 1}$$

Where:

- T_R = Time to reset in seconds
- R = Constant for the particular curve
- D = TIME DIAL setting
- M = Current in multiples of PICKUP setting during reset

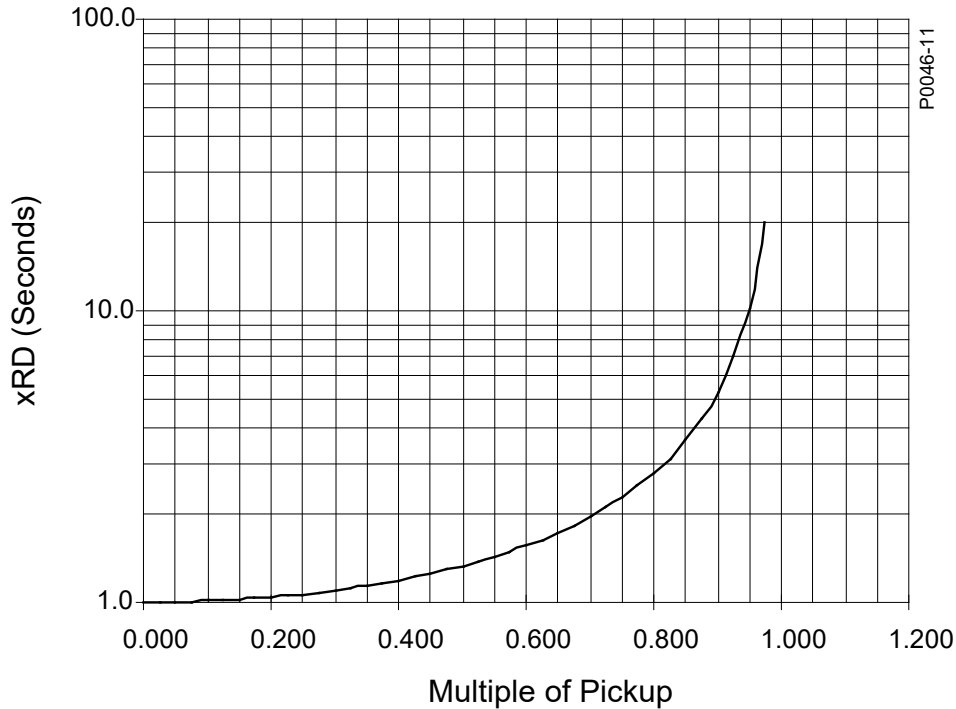

Vertical axis xRD (Seconds) is applicable for all curves and is derived from multiplying the constant R for the curve selected times D (the Time Dial setting).

Figure 6-1. Integrating Reset Characteristic Curve

Instantaneous Overcurrent (50) Element

Setting the INST PICKUP control to the minimum pickup setting (0.2 on the 1-ampere unit and 1.0 on the 5-ampere unit), places the relay in the most sensitive state and may be used as a safety setting.

1-Ampere Unit Pickup

- Setting Range0.2 to 19.8 Aac
- Setting Increment0.2 Aac
- Accuracy.....±2%, ±5 milliamperes at or above 0.2 ampere setting

5-Ampere Unit Pickup

- Setting Range 1 to 99 Aac
- Setting Increment 1 Aac
- Accuracy.....±2%, ±25 milliamperes at or above 1.0 ampere setting

Dropout

Dropout occurs at 95% of pickup value.

Curve Characteristics

BE1-50/51M instantaneous characteristic curves are similar to standard electromechanical instantaneous units. However, the time to trip for ground applications is slightly longer than that for phase applications to allow time to power up the relay. Longer trip time for ground applications is beneficial because it helps to avoid nuisance trips.

For phase applications, the maximum time to trip is 3.5 cycles at a pickup multiple of 1.0, and 1.5 cycles at a pickup multiple of 3.0. The corresponding times for ground applications are 4.5 and 1.75 cycles. Figure 6-2 shows the instantaneous characteristic curves for maximum time to trip.

On 100 series relays, additional delays of 0.1, 0.2, or 0.3 seconds may be added with internal switches SW3-2 and SW3-3. These delays apply to both phase and ground applications. Closing switch SW3-2 provides an additional delay of 0.1 second. Closing switch SW3-3 provides an additional delay of 0.2 second. Closing both switches SW3-2 and SW3-3 provides an additional delay of 0.3 second. Section 2 illustrates the location of SW3.

On 200 series relays, an additional delay of 0.1 second may be added with internal switch SW3-2. This delay applies to both phase and ground applications. Closing switch SW3-2 provides the additional delay of 0.1 second.

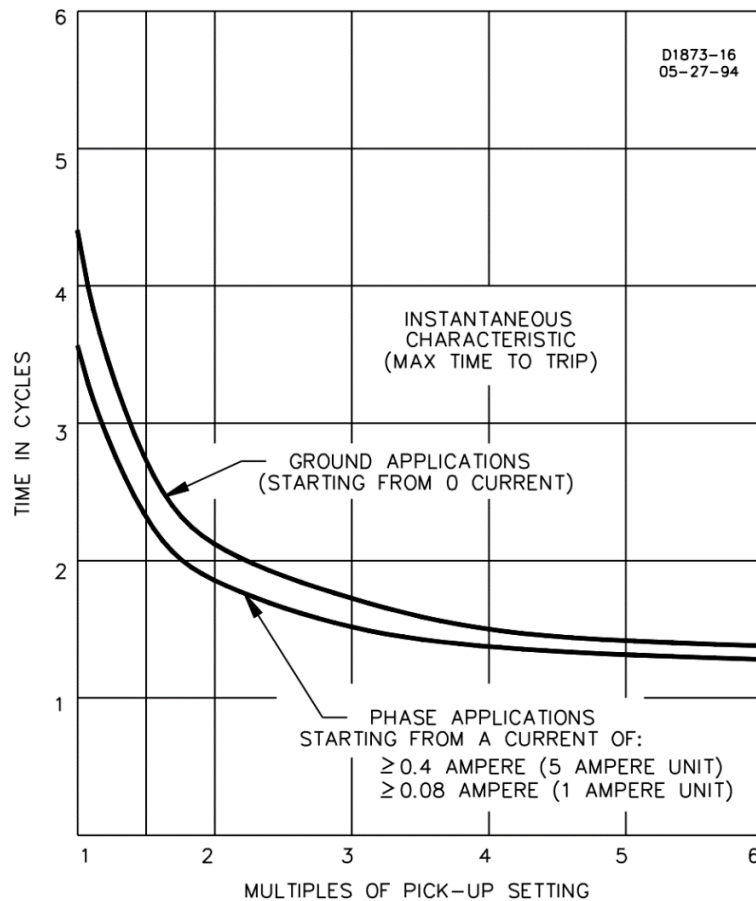

Figure 6-2. Instantaneous Characteristic Curves

General Specifications

Current Sensing Input

1-Ampere Unit

Continuous Current 2.8 Aac
 One Second Rating 80 Aac

5-Ampere Unit

Continuous Current 14 Aac
 One Second Rating 400 Aac

Burden

Burden is non-linear. Figure 6-3 illustrates the device burden.

1 Ampere Unit

0.1 amperes Z = 110 Ω
 1.0 ampere Z = 6 Ω

5 Ampere Unit

0.5 amperes Z = 4.4 Ω
 5.0 amperes Z = 0.2 Ω

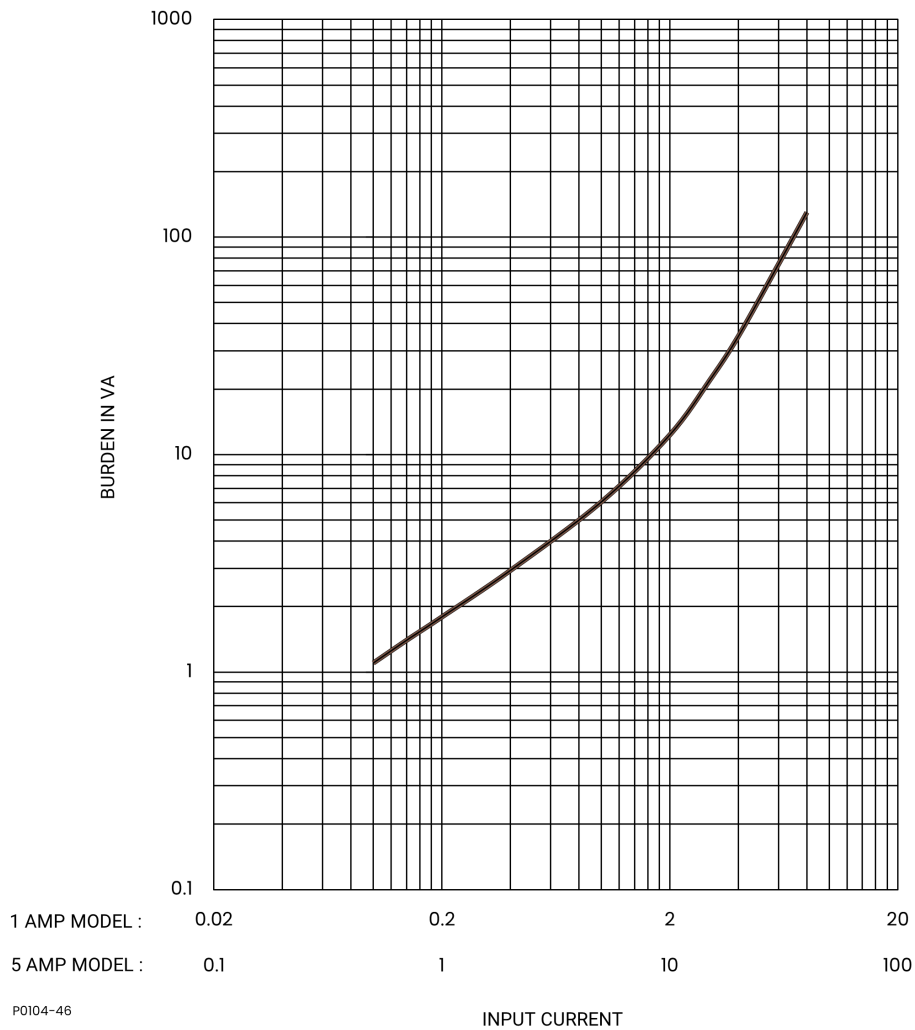

Figure 6-3. Burden Characteristics

Frequency Response

A change of ±5 Hz from the nominal 50/60 Hz current causes <0.5% change in the current required for pickup.

Transient Response

<10% overreach with system time constants up to 40 ms.

Harmonic Response

Figure 6-4 shows that a relay set for 1 ampere pickup would pick up at 0.96 amperes with a current containing 40% seventh harmonic. This corresponds to a 10:1 rejection ratio. Other conditions may be evaluated in the same manner.

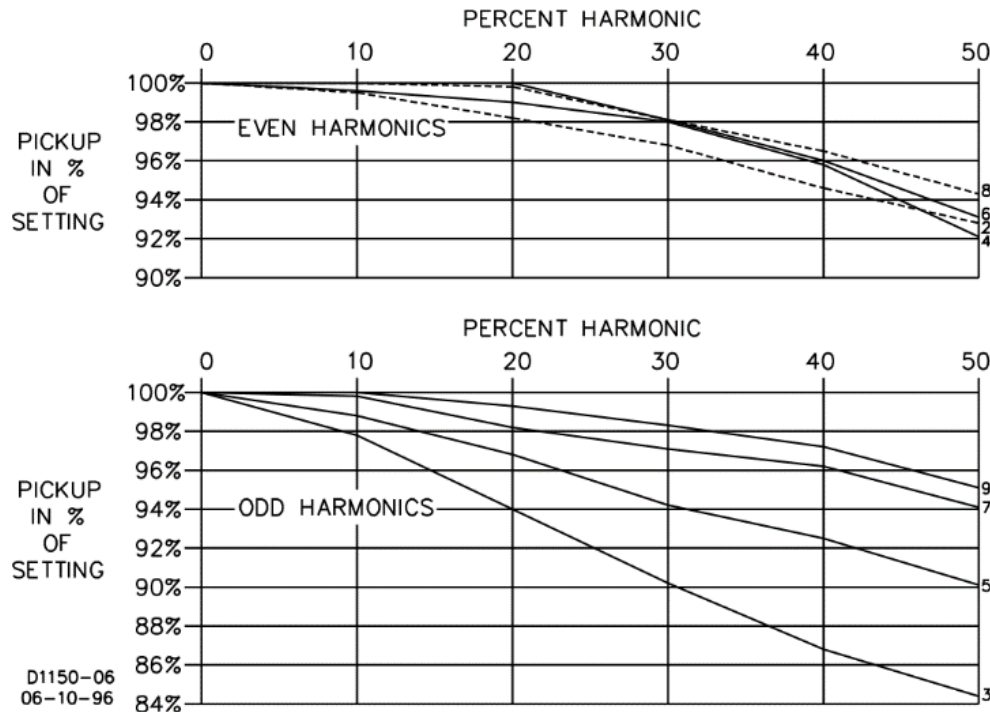

Figure 6-4. Harmonic Rejection

Target Indicators

Gravity-latched, manually reset targets indicate that current of 0.2 amperes or greater was present in the trip circuit. Target coil resistance is less than 0.1 ohms and operate time is less than one millisecond. See *Output Contacts* for maximum current rating. The level of trip circuit current required to operate each target is individually controlled by a circuit board jumper. See Section 2, *Controls and Indicators* for jumper locations and function assignments.

Target Operate Current

Jumper Position—Pins 1 and 2: Must operate ≥ 2.25 A; must not operate < 900 mA. *

Jumper Position—Pins 2 and 3: Must operate ≥ 200 mA; must not operate < 80 mA. *

* See *Output Contacts* for the maximum acceptable levels of trip circuit currents.

Output Contacts

Output contacts are surge protected and rated as follows:

Resistive Ratings

120/240 Vac Make 30 amperes for 0.2 seconds, carry 7 amperes for 2 minutes, 3 amperes continuously, and break 5 amperes.

125/250 Vdc Make 30 amperes for 0.2 seconds, carry 7 amperes for 2 minutes, 3 amperes continuously, and break 0.3 ampere.

Inductive Ratings

120/240 Vac, 125/250 Vdc.....Make and carry 30 amperes for 0.2 seconds, carry 7 amperes for 2 minutes, 3 amperes continuously, and break 0.3 ampere. (L/R = 0.04).

AUX Output Contact

The AUX Output contact can be configured in the field using jumpers to select closing on either timed or instantaneous trip. The AUX output contact is surge protected and has the same ratings as the output contacts above.

Type Tests

Isolation IEEE C37.90-2005
Transient Surge IEEE C37.90.1-2004
Radiated Interference IEEE C37.90.2-2004
Electrostatic Discharge IEEE C37.90.3-2006
Vibration IEC 255-21-1
Shock and Bump IEC 255-21-2

Environment

Operating Temperature -40°C to 70°C (-40°F to 158°F)
Storage Temperature -50°C to 70°C (-58°F to 158°F).

Agency Recognition

UL Recognized

This product is cURus recognized per the applicable U.S. and Canadian safety standards and requirements by UL.

Note: Output contacts are not UL Recognized for voltages greater than 250 volts.

China RoHS

The following table serves as the declaration of hazardous substances for China in accordance with PRC standard SJ/T 11364-2014. The EFUP (Environment Friendly Use Period) for this product is 40 years.

PRODUCT: BE1-50/51M										
零件名称 Part Name	有害物质 Hazardous Substances									
	铅 Lead (Pb)	汞 Mercury (Hg)	镉 Cadmium (Cd)	六价铬 Hexavalent Chromium (Cr ⁶⁺)	多溴联苯 Polybrominated Biphenyls (PBB)	多溴二苯醚 Polybrominated Diphenyl Ethers (PBDE)	邻苯二甲 酸二丁酯 Dibutyl Phthalate (DBP)	邻苯二甲 酸丁苄酯 Benzyl butyl phthalate (BBP)	邻苯二甲 酸二酯 Bis(2- ethylhexyl) phthalate (BEHP)	邻苯二甲 酸二异丁 酯 Diisobutyl phthalate (DIBP)
金属零件 Metal parts	X	O	X	O	O	O	O	O	O	O
聚合物 Polymers	O	O	O	O	O	X	O	O	O	O
电子产品 Electronics	X	O	X	O	O	O	O	O	O	O
电缆和互连 配件 Cables & interconnect accessories	X	O	O	O	O	O	O	O	O	O
绝缘材料 Insulation material	O	O	O	O	O	O	O	O	O	O

本表格依据 SJ/T11364 的规定编制。

O: 表示该有害物质在该部件所有均质材料中的含量均在 GB/T 26572 规定的限量要求以下。

X: 表示该有害物质至少在该部件的某一均质材料中的含量超出 GB/T 26572 规定的限量要求。

This form was prepared according to the provisions of standard SJ/T11364.

O: Indicates that the hazardous substance content in all homogenous materials of this part is below the limit specified in standard GB/T 26572.

X: Indicates that the hazardous substance content in at least one of the homogenous materials of this part exceeds the limit specified in standard GB/T 26572.

Patent

Patented in U.S., 1998, U.S. Patent No. 5751532.

Physical

Weight5.2 lb (2.3 kg)

7 • Relay Differences

The following information is provided to support BE1-50/51B relays purchased before fall 2024. For BE1-50/51B 100 series relays, revision S and previous, refer to page 7-3.

BE1-50/51B relay boards with these revisions have the locations for controls shown in Figure 7-1. Table 7-1 lists and briefly describes the operator controls of these relays. Reference the callout letters to Figure 7-1.

Table 7-1. BE1-50/51B Controls

Locator	Control or Indicator	Function
J	SW3-1	SW3-1 selects the system operating frequency. Opening SW3-1 (OFF) selects 60-hertz operation. Closing SW3-1 (ON) selects 50-hertz operation.
	SW3-2	SW3-2 selects additional delay for the instantaneous element. Closing SW3-2 (ON) provides an additional instantaneous delay of 0.1 seconds.
	SW3-3	<u>100 Series Relays</u> Closing SW3-3 (ON) provides an additional instantaneous delay of 0.2 seconds. Closing both SW3-2 (ON) and SW3-3 (ON) provides an additional instantaneous delay of 0.3 seconds. <u>200 Series Relays</u> Opening SW3-3 (OFF) selects ABB type curves. Closing SW3-3 (ON) selects GE IAC type curves.
	SW3-4	SW3-4 provides selection of either instantaneous or integrating reset characteristics. Closing SW3-4 (ON) selects integrating reset characteristics. Opening SW3-4 (OFF) selects instantaneous reset characteristics. See the <i>Specifications</i> chapter for details on time reset.
K	Auxiliary Output Jumper Terminations	Configures the auxiliary output contacts to close with either the instantaneous (50) trip and/or the timed (51) trip. Jumper E2 to E1A to close the auxiliary contact with the timed (51) trip. This jumper is factory-installed to close the auxiliary output contacts with the timed trip. Jumper E3 to E1B to close the auxiliary contact with the instantaneous (50) trip. This jumper is factory-installed to close the auxiliary output contacts with the instantaneous trip.

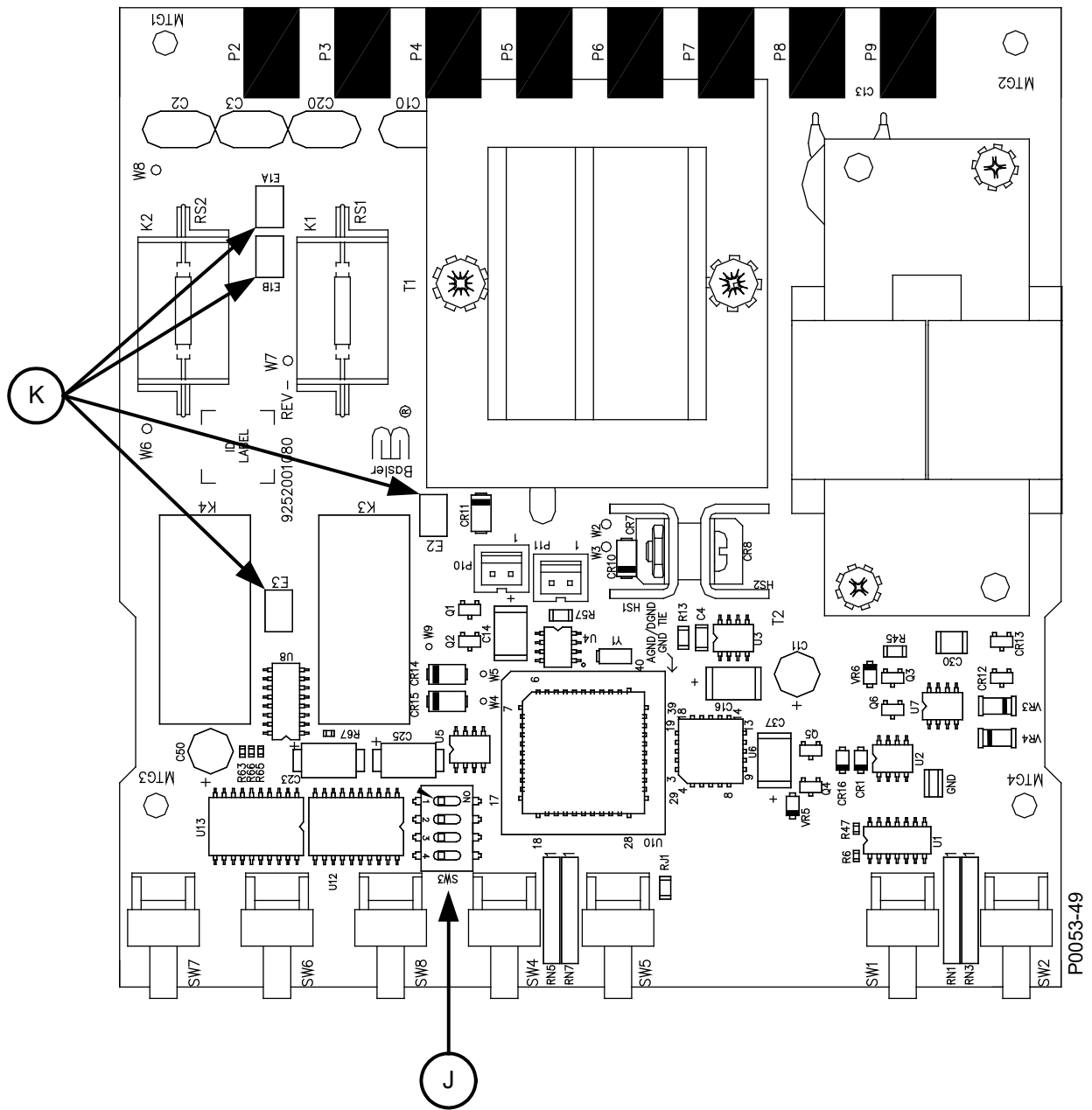

Figure 7-1. Location of SW3 and Auxiliary Output Jumper Terminations

The following information is provided to support BE1-50/51B 100 series relays, revision S and previous. In all unit revisions R and previous, SW3 is the same as SW8.

BE1-50/51M 100 series relay boards revision Q and previous have the locations for controls and indicators shown in Figure 7-2. BE1-50/51M 100 series relays, unit revisions R and S and 200 series relays, unit revisions H and previous have the locations for controls shown in Figure 7-3. Table 7-2 lists and briefly describes the operator controls of these relays. Reference the callout letters to Figure 7-2 and Figure 7-3.

Table 7-2. BE1-50/51B Controls and Indicators for 100 Series Relays Revision Q and Previous

Locator	Control	Function
J	SW8-1	SW8-1 selects the system operating frequency. SW8-1 open (OFF) selects 60-hertz operation. SW8-1 closed (ON) selects 50-hertz operation.
	SW8-2	In 100 and 200 series relays, SW8-2 selects additional delay for the instantaneous element. Switch SW8-2 closed (ON) provides an additional instantaneous delay of 0.1 seconds.
	SW8-3	In 100 series relays, switch SW8-3 closed (ON) provides an additional instantaneous delay of 0.2 seconds. Closing both switches SW8-2 and SW8-3 provides an additional instantaneous delay of 0.3 seconds. In 200 series relays, SW8-3 open (OFF) selects ABB type curves. SW8-3 closed (ON) selects GE IAC type curves.
	SW8-4	Provides selection of either instantaneous or integrating reset characteristic. SW8-4 closed (ON) provides integrating reset. SW8-4 open (OFF) provides instantaneous reset.
K	Auxiliary Output Jumper Terminations	Configures the auxiliary output contacts to close with either the instantaneous (50) trip and/or the timed (51) trip. Jumper E2 to E1A to close the auxiliary contact with the timed (51) trip. This jumper is yellow and factory-installed to close the auxiliary output contacts with the timed trip. Jumper E3 to E1B to close the auxiliary contact with the instantaneous (50) trip. This jumper is blue and factory-installed to close the auxiliary output contacts with the instantaneous trip.

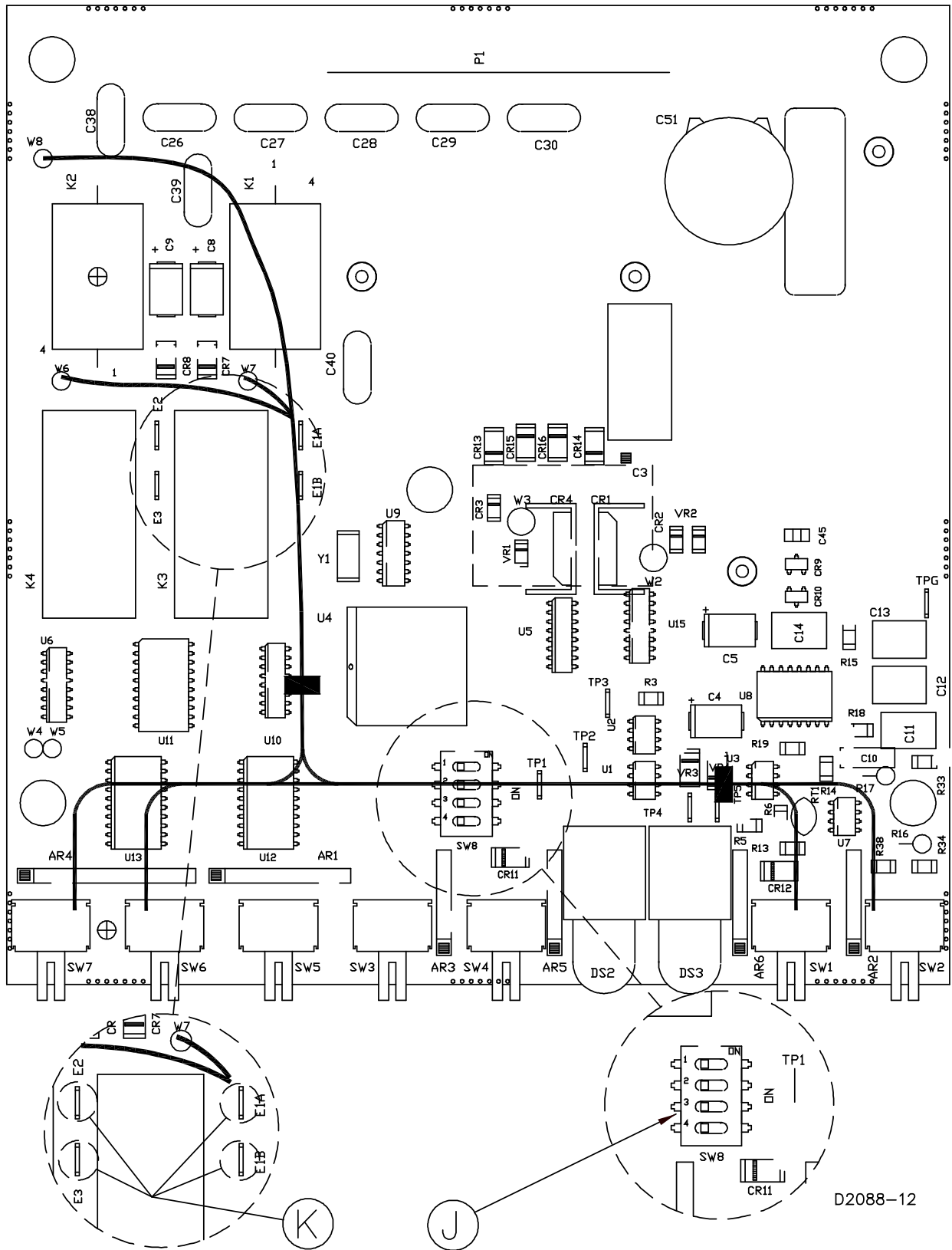

Figure 7-2. Location of Controls and Indicators for Unit Revision Q and Previous, 100 Series Relays

BE1-50/51M Chassis and Case Assembly Modification

The chassis and case assembly were modified on BE1-50/51M 100 and 200 series vertical-mount relays, with the revisions listed in Table 7-3. The chassis assembly for these revisions is not backwards compatible with case assemblies on relays with previous revisions. A newer chassis assembly must be used with a newer case assembly.

Table 7-3. BE1-50/51M Revisions

Model	Revision
BE1-50/51M-108	AH
BE1-50/51M-109	AH
BE1-50/51M-208	Z
BE1-50/51M-209	Z

8 • Time Characteristic Curves

Figure 8-1 through Figure 8-9 illustrate the time characteristic curves that are programmed into the nonvolatile memory of series 100 relays. Figure 8-1 through Figure 8-14 illustrate the characteristic curves that are programmed into the nonvolatile memory of series 200 relays.

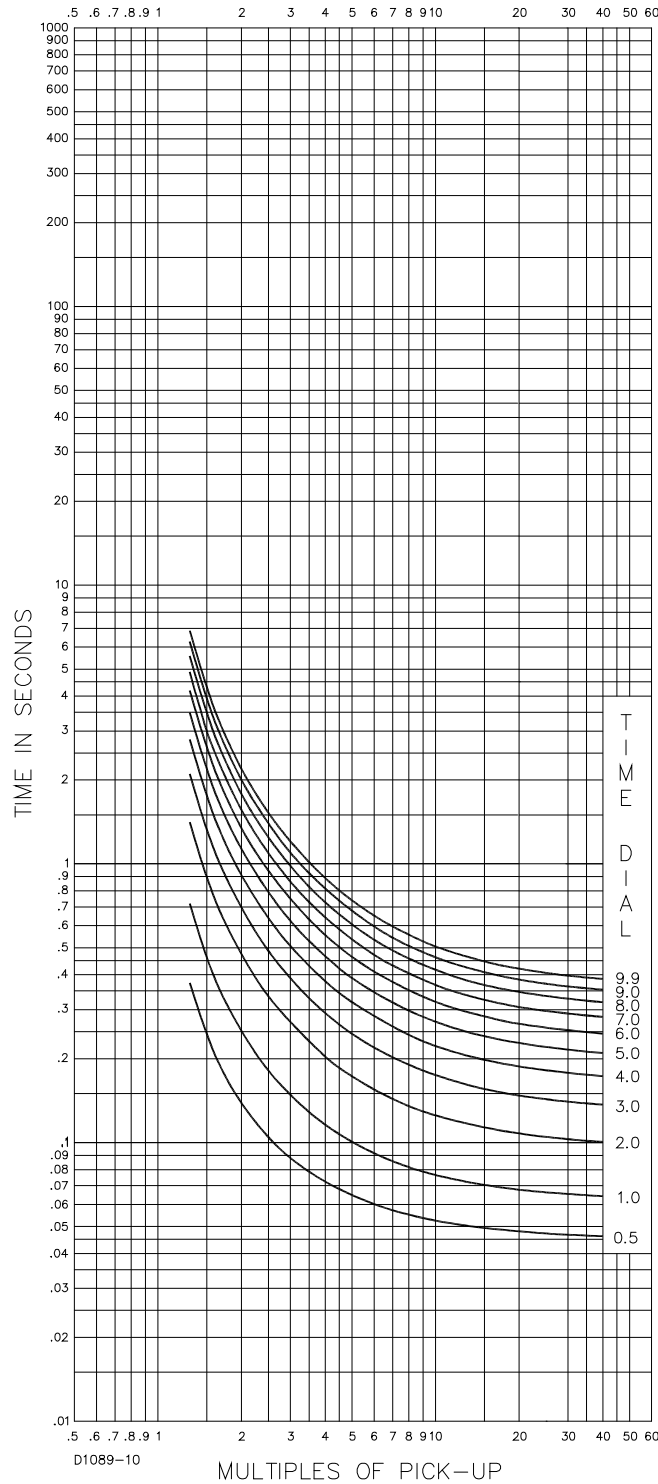

Figure 8-1. Time Characteristic Curve, S-Short Inverse (SW3-3 OFF, Similar to ABB CO-2)

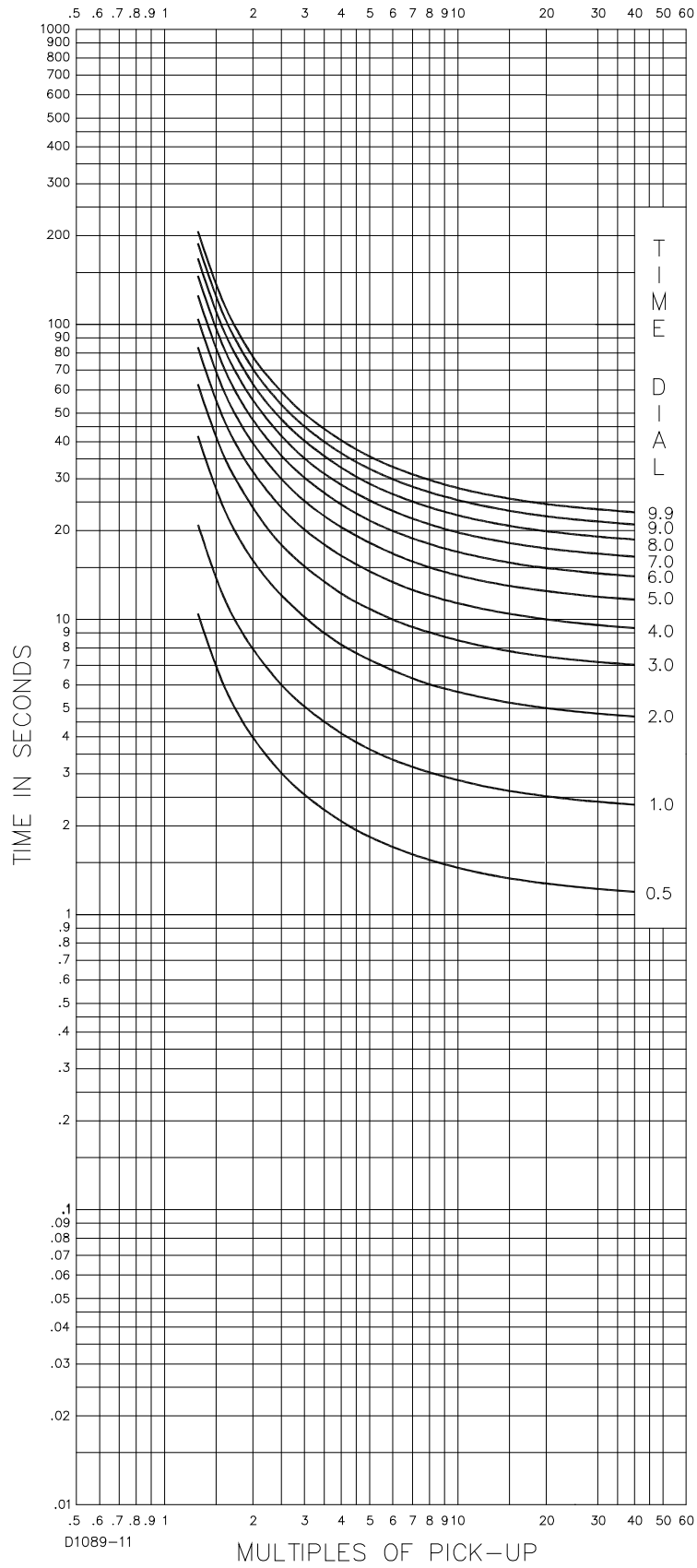

Figure 8-2. Time Characteristic Curve, L-Long Inverse (SW3-3 OFF, Similar to ABB CO-5)

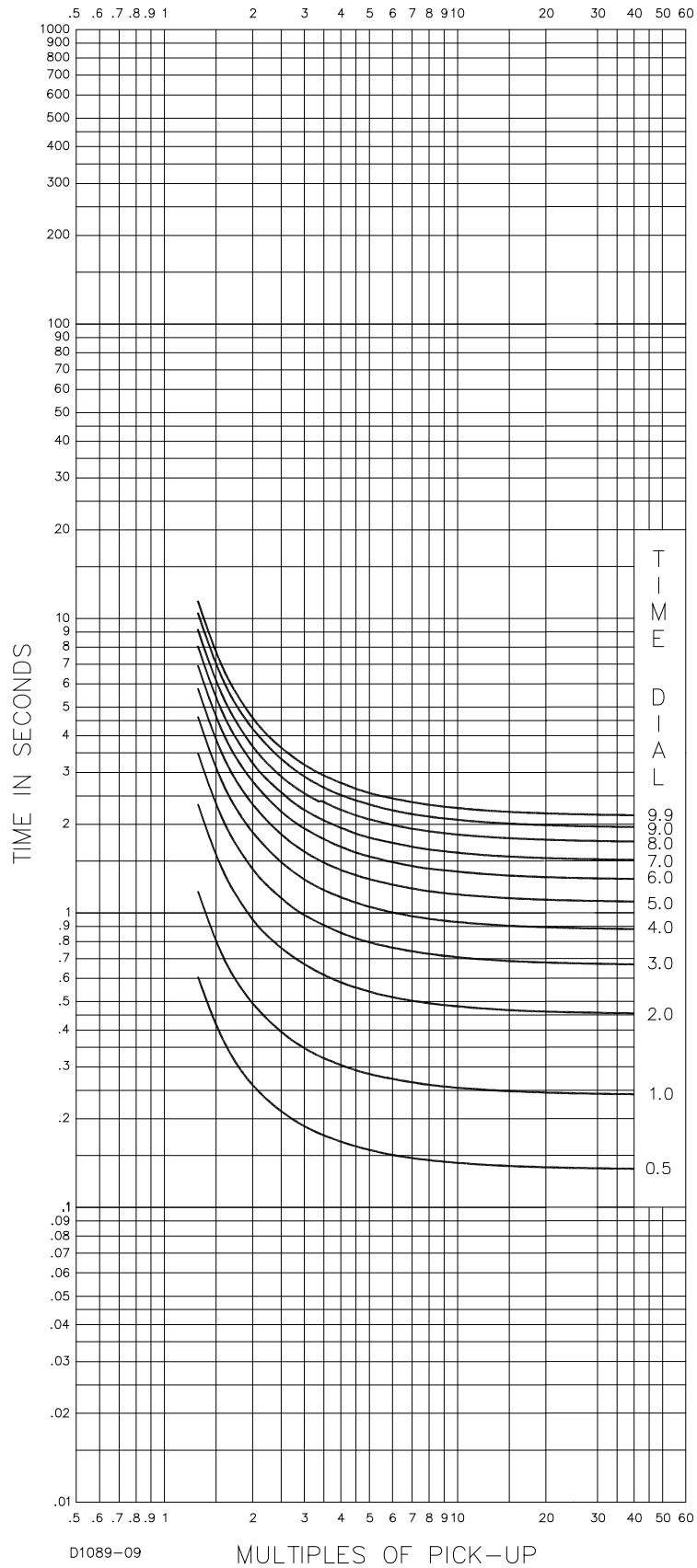

Figure 8-3. Time Characteristic Curve, D-Definite Time (Similar to ABB CO-6)

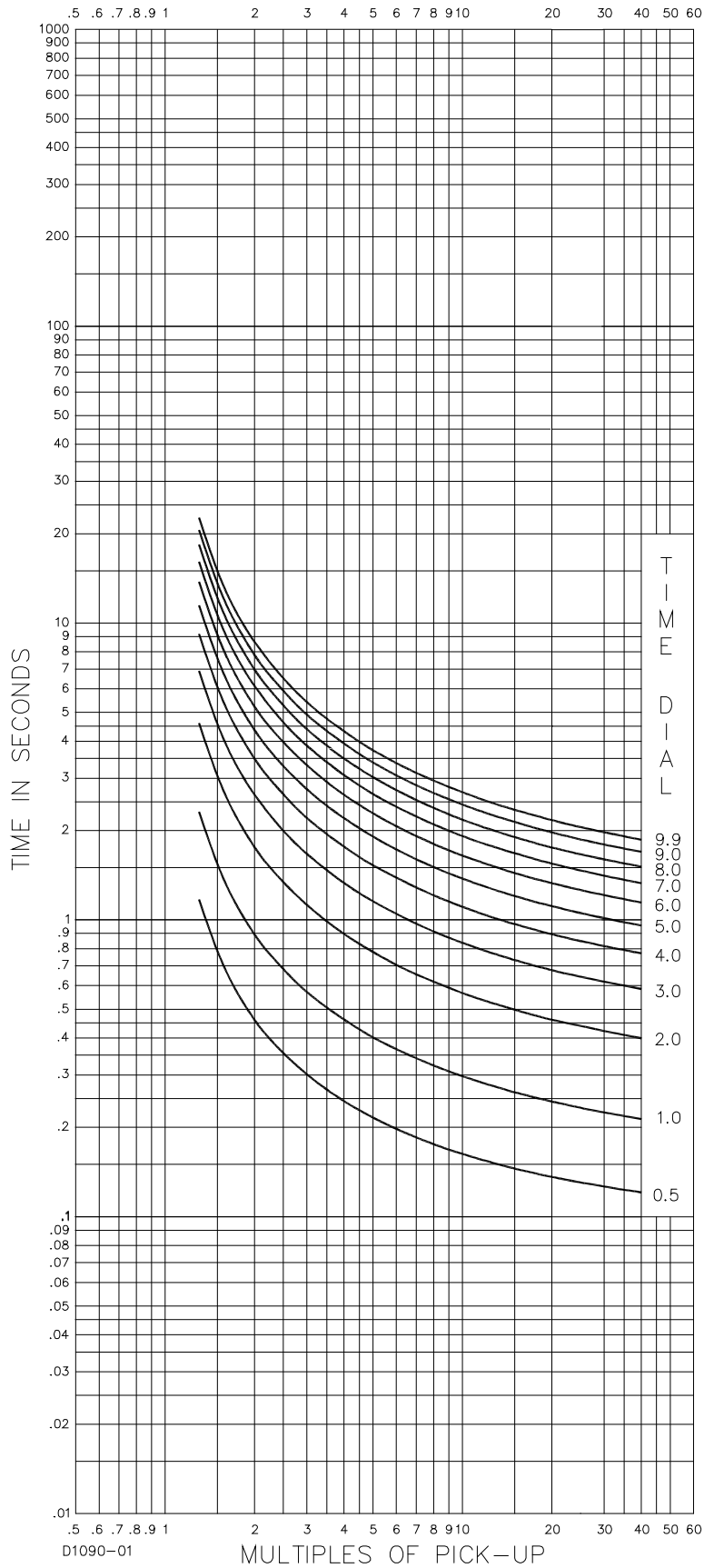

Figure 8-4. Time Characteristic Curve, M-Moderately Inverse (Similar to ABB CO-7)

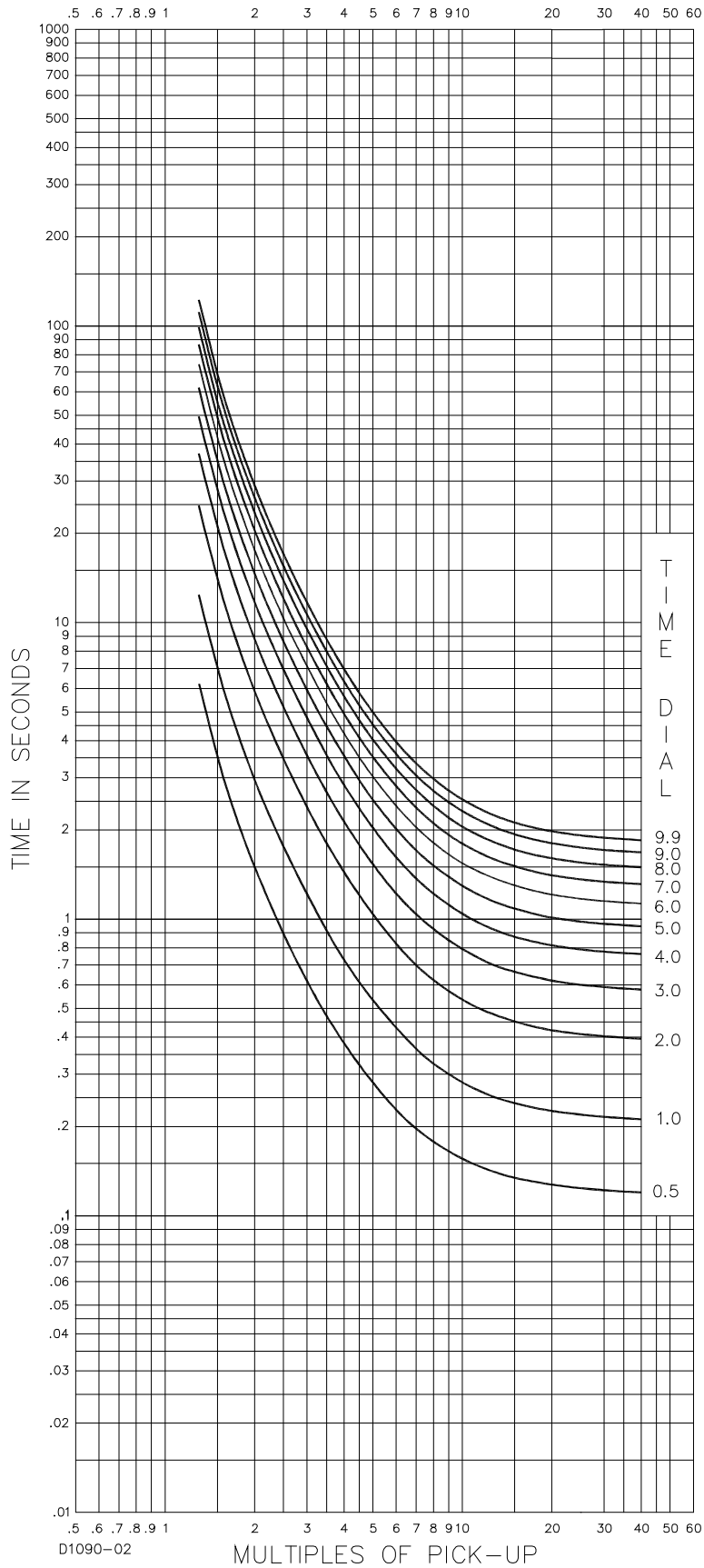

Figure 8-5. Time Characteristic Curve, I-Inverse (SW3-3 OFF, Similar to ABB CO-8)

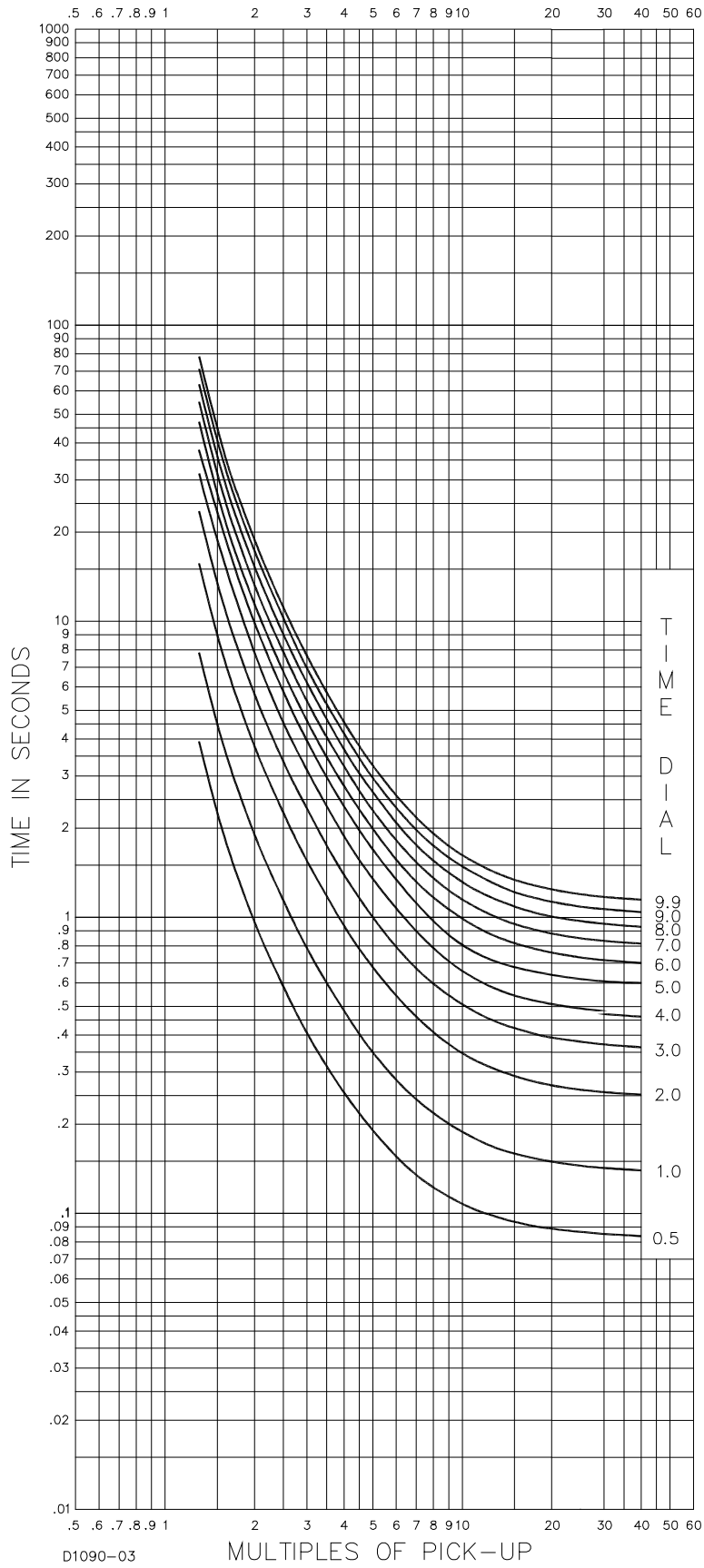

Figure 8-6. Time Characteristic Curve, V-Very Inverse (SW3-3 OFF, Similar to ABB CO-9)

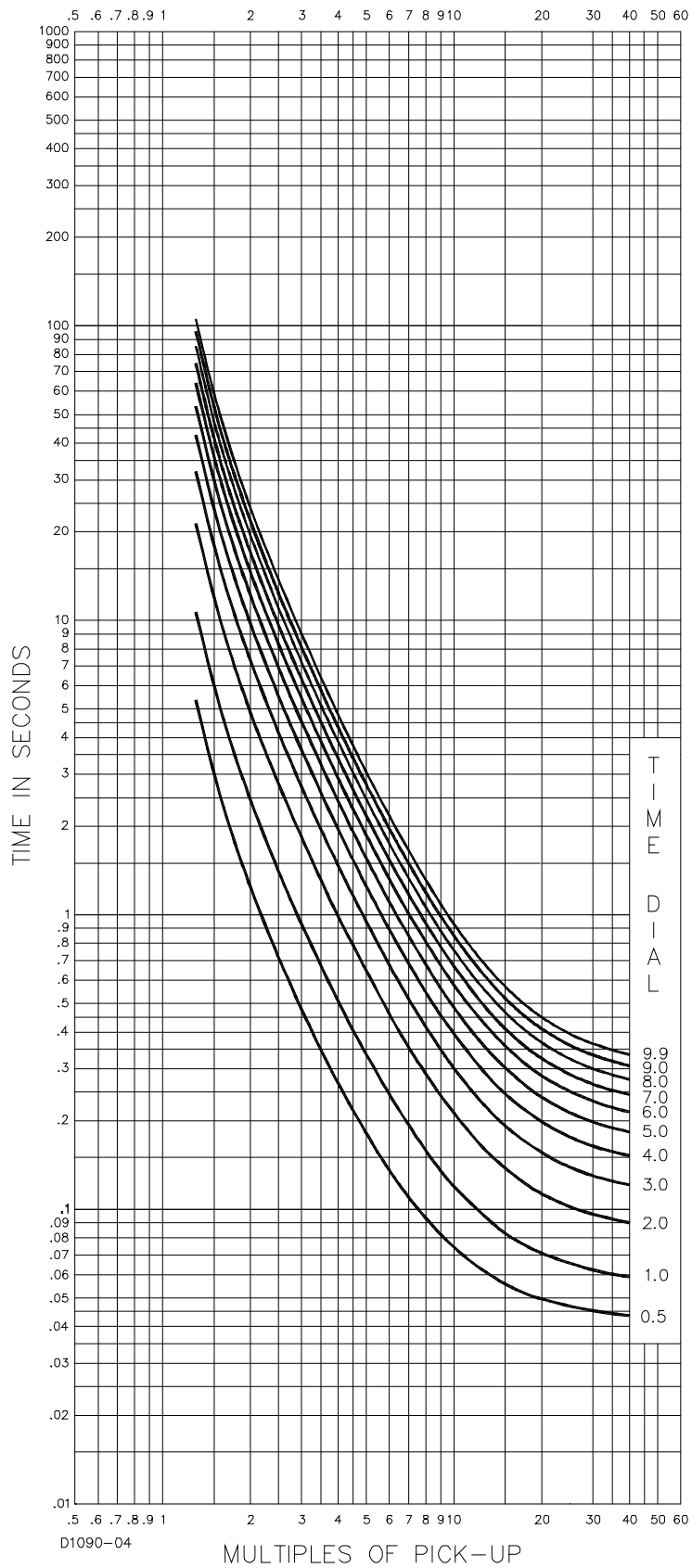

Figure 8-7. Time Characteristic Curve, E-Extremely Inverse (SW3-3 OFF, Similar to ABB CO-11)

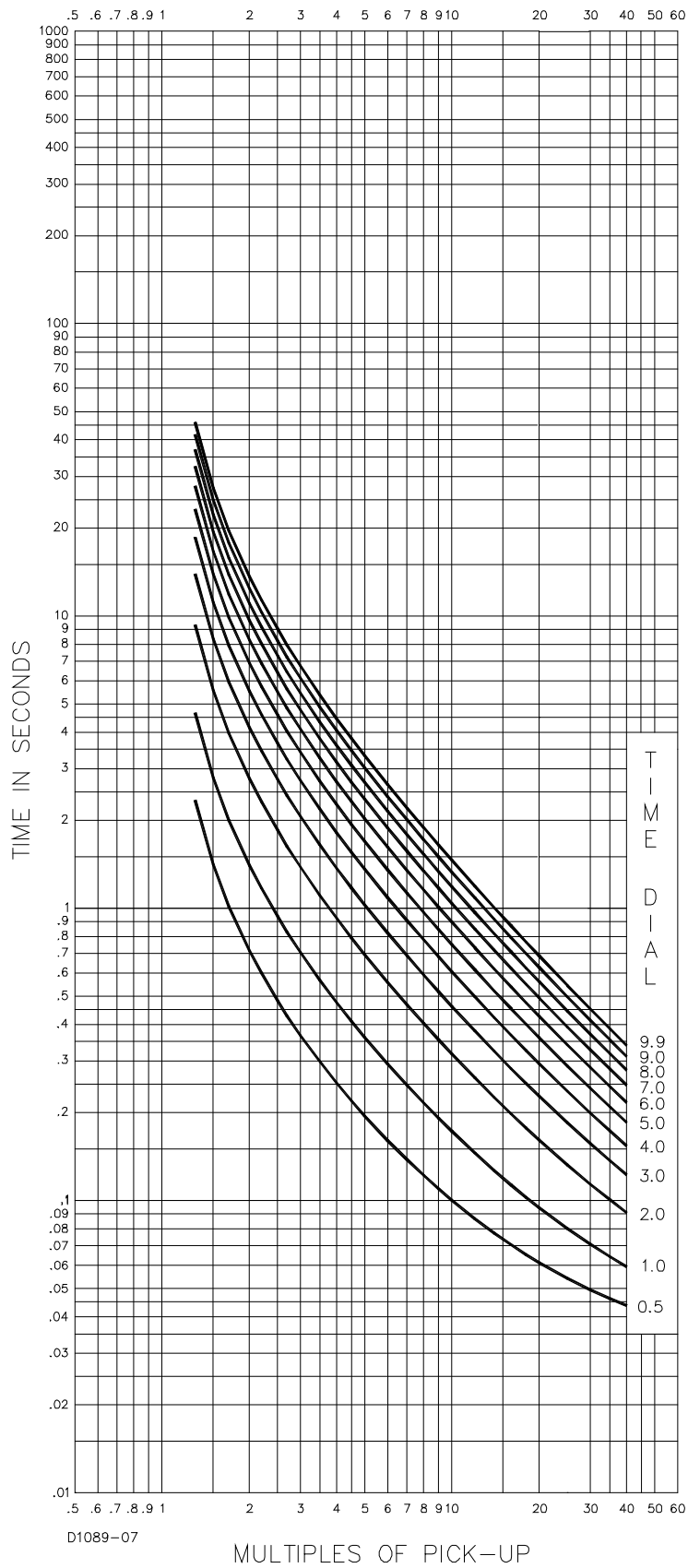

Figure 8-8. Time Characteristic Curve, BS142-B (BS142 Very Inverse)

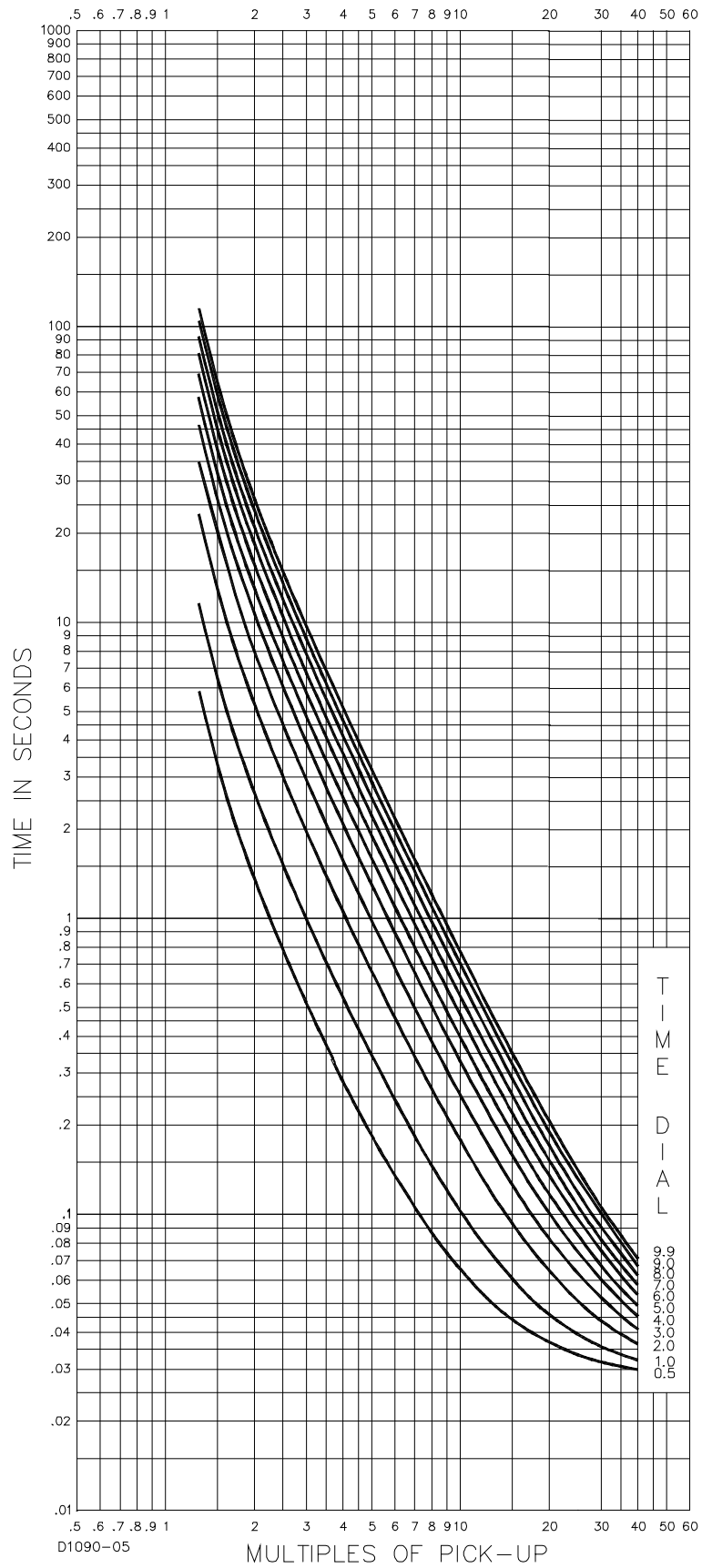

Figure 8-9. Time Characteristic Curve, BS142-C (BS142 Extremely Inverse)

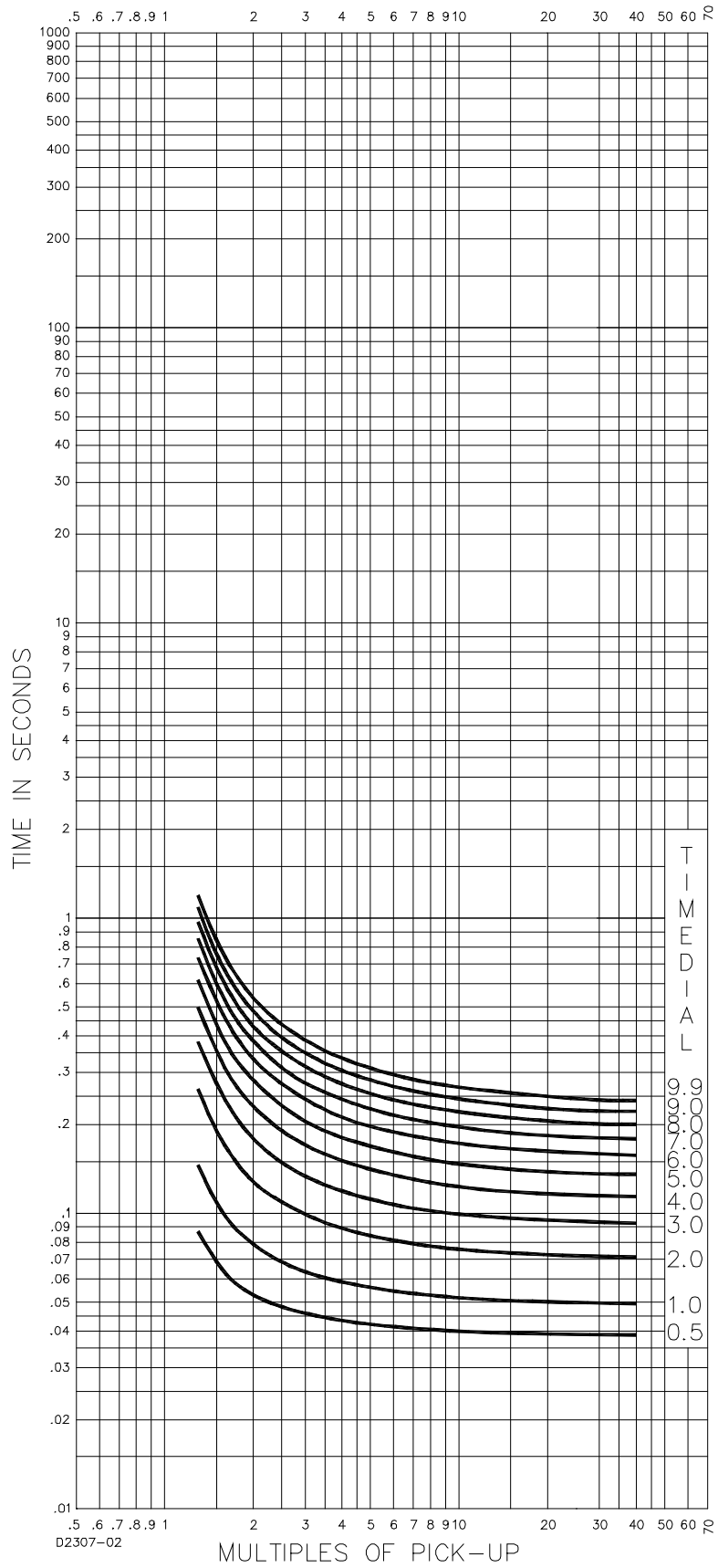

Figure 8-10. Time Characteristic Curve, S2-Short Inverse (SW3-3 ON, Similar to GE IAC 55)

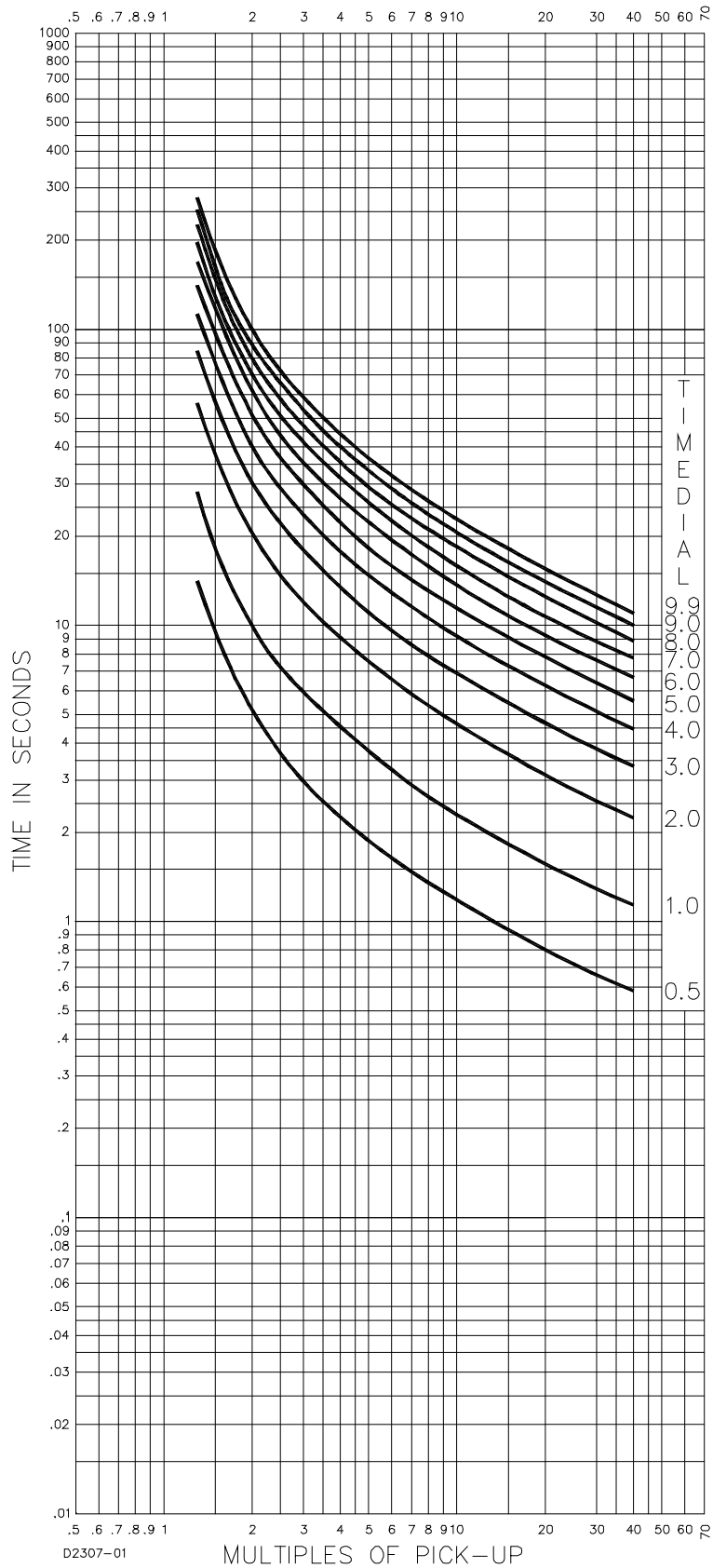

Figure 8-11. Time Characteristic Curve, L2-Long Inverse (SW3-3 ON, Similar to GE IAC 66)

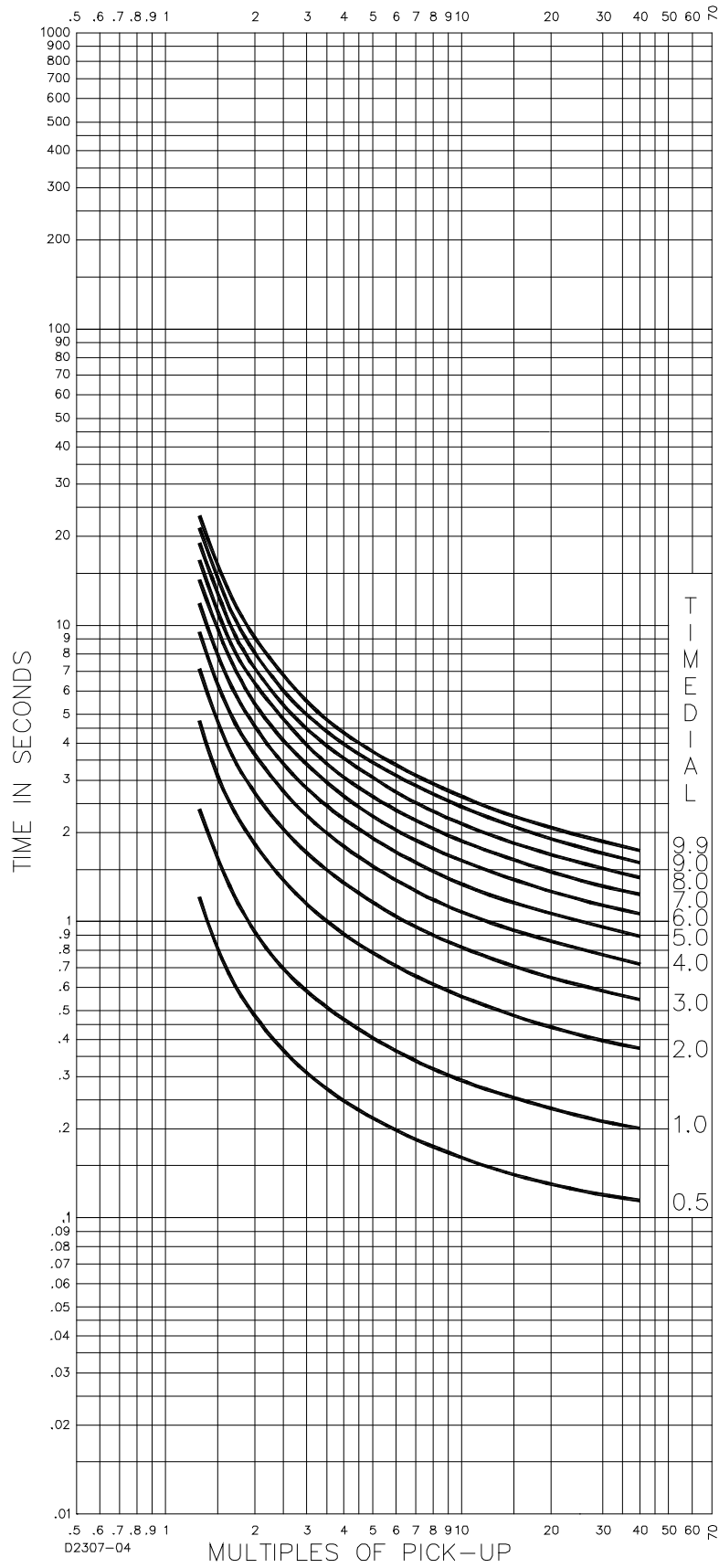

Figure 8-12. Time Characteristic Curve, I2-Inverse (SW3-3 ON, Similar to GE IAC 51)

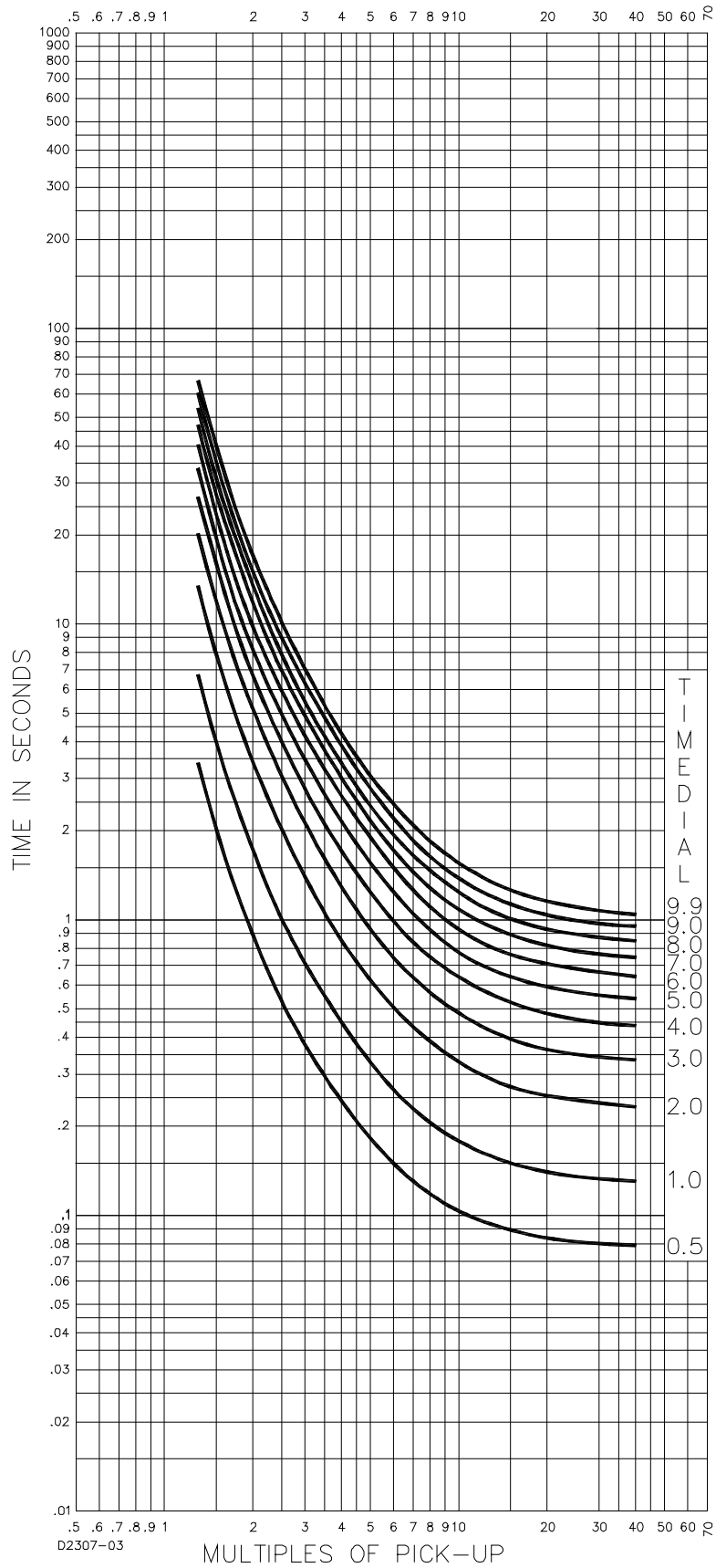

Figure 8-13. Time Characteristic Curve, V2-Very Inverse (SW3-3 ON, Similar to GE IAC 53)

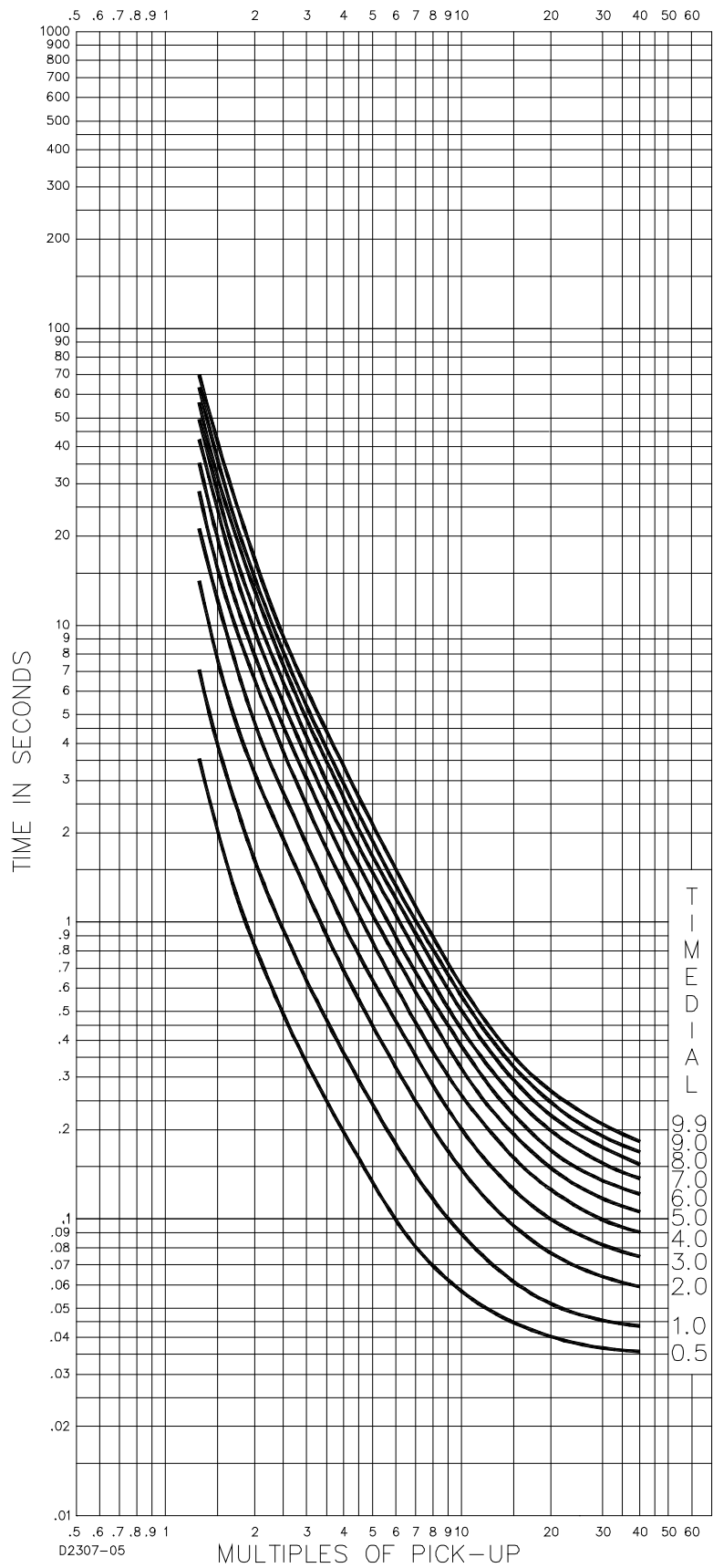

Figure 8-14. Time Characteristic Curve, E2-Extremely Inverse (SW3-3 ON, Similar to GE IAC 77)



Highland, Illinois USA
Tel: +1 618.654.2341
Fax: +1 618.654.2351
email: info@basler.com

Suzhou, P.R. China
Tel: +86 512.8227.2888
Fax: +86 512.8227.2887
email: chinainfo@basler.com