

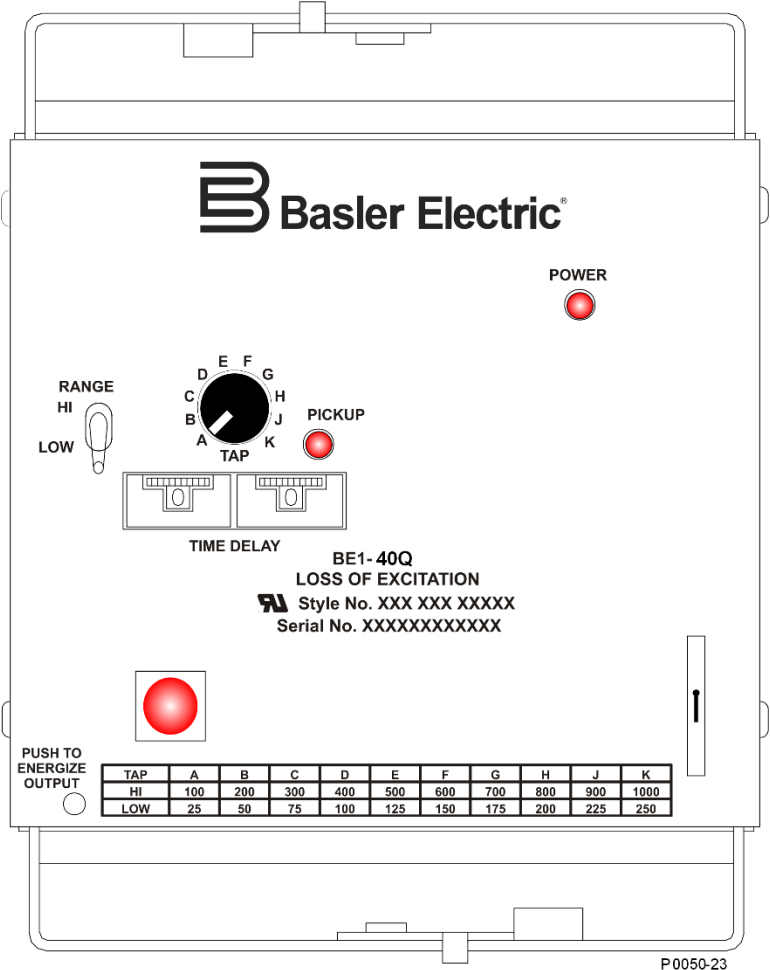



BE1-40Q

Loss of Excitation Relay

Instruction Manual



 **WARNING:** California's Proposition 65 requires special warnings for products that may contain chemicals known to the state of California to cause cancer, birth defects or other reproductive harm. Please note that by posting this Proposition 65 warning, we are notifying you that one or more of the Proposition 65 listed chemicals may be present in products we sell to you. For more information about the specific chemicals found in this product, please visit <https://www.basler.com/Prop65>.

Preface

This instruction manual provides information about the installation and operation of the BE1-40Q relay. To accomplish this, the following information is provided:

- General information and specifications
- Controls and indicators
- Functional description
- Installation
- Setting and testing

Conventions Used in this Manual

Important safety and procedural information is emphasized and presented in this manual through warning, caution, and note boxes. Each type is illustrated and defined as follows.

Warning!

Warning boxes call attention to conditions or actions that may cause personal injury or death.

Caution

Caution boxes call attention to operating conditions that may lead to equipment or property damage.

Note

Note boxes emphasize important information pertaining to installation or operation.



12570 State Route 143
Highland IL 62249-1074 USA

www.basler.com
info@basler.com

Tel: +1 618.654.2341

Fax: +1 618.654.2351

© 2022 by Basler Electric

All rights reserved

First printing: November 1986

Warning!

READ THIS MANUAL. Read this manual before installing, operating, or maintaining this equipment. Note all warnings, cautions, and notes in this manual as well as on the product. Keep this manual with the product for reference. Only qualified personnel should install, operate, or service this system. Failure to follow warning and cautionary labels may result in personal injury or property damage. Exercise caution at all times.

Basler Electric does not assume any responsibility to compliance or noncompliance with national code, local code, or any other applicable code. This manual serves as reference material that must be well understood prior to installation, operation, or maintenance.

For terms of service relating to this product and software, see the *Commercial Terms of Products and Services* document available at www.basler.com/terms.

This publication contains confidential information of Basler Electric Company, an Illinois corporation. It is loaned for confidential use, subject to return on request, and with the mutual understanding that it will not be used in any manner detrimental to the interests of Basler Electric Company and used strictly for the purpose intended.

It is not the intention of this manual to cover all details and variations in equipment, nor does this manual provide data for every possible contingency regarding installation or operation. The availability and design of all features and options are subject to modification without notice. Over time, improvements and revisions may be made to this publication. Before performing any of the following procedures, contact Basler Electric for the latest revision of this manual.

The English-language version of this manual serves as the only approved manual version.

Revision History

A historical summary of the changes made to this instruction manual is provided below. Revisions are listed in reverse chronological order.

Instruction Manual Revision History

Manual Revision and Date	Change
S, May 2022	<ul style="list-style-type: none"> Added a note about EMI suppression in the <i>Installation</i> chapter.
R, Dec 2021	<ul style="list-style-type: none"> Adjusted style chart to reflect obsolescence of current-operated targets. Updated manual to new style.
Q	<ul style="list-style-type: none"> This revision letter not used.
P, Oct 2021	<ul style="list-style-type: none"> Updated timing accuracy spec on page 1-4. Updated equation on page 3-2.
O	<ul style="list-style-type: none"> This revision letter not used.
N2, Apr 2019	<ul style="list-style-type: none"> Replaced Prop 65 warning with generic version.
N1, Oct 2018	<ul style="list-style-type: none"> Added Prop 65 warning on back of cover page.
N, Dec 2012	<ul style="list-style-type: none"> Standardized case and cover drawings in Section 4.
M, Jan 2011	<ul style="list-style-type: none"> Updated equations in Note 1 under Figure 5-2. Improved timing specs under <i>Operational Test, Timing Verification</i> in Section 5.
L, Sep 2007	<ul style="list-style-type: none"> Added manual part number and revision to footers. Updated Output Contact ratings in Section 1. Updated Power Supply Burden data in Section 1. Updated front panel illustrations to show laser graphics. Updated Target Indicator description in Section 3. Added GOST-R to Section 1, <i>General Information</i>. Moved content of Section 7, <i>Manual Change Information</i> to <i>Manual Introduction</i>. Moved content of Section 6, <i>Maintenance</i> to Section 4, <i>Installation</i>.
K, Feb 2001	<ul style="list-style-type: none"> Updated S1 case drawings in Section 4 to the most recent drawings.
J, Oct 1998	<ul style="list-style-type: none"> Corrected Voltage Sensing in <i>Specifications</i> from “Each have a burden that is less than 0.1 ohm over the” to “Each have a burden that is less than 1 VA over the”. Deleted 500 Vdc from <i>Resistive Output Circuits</i>. Deleted all references to Service Manual. Updated Style Number Identification Chart by changing Power Supply Type T from “230 Vac” to “240 Vac”. Added new power supply information to Specifications and Section 3 starting with “Basler Electric enhanced the power supply design...” Changed the format of the manual.
I	<ul style="list-style-type: none"> This revision letter not used.

Manual Revision and Date	Change
H, Mar 1995	<ul style="list-style-type: none"> • Changed Section 1, <i>General Information, Specifications, Output Circuits and Isolation</i>. • Added phase rotation sensitivity information to Section 3, <i>Functional Description</i>. • Changed Section 4, <i>Installation, Dielectric Test</i>, to reflect specification changes. • Corrected Figure 4-1 and changed Figure 5-2, note 2. • Corrected typographical error in Table 5-4, <i>Reactive Power (Vars)</i>, +120. • Corrected typographical error in Section 6, <i>Maintenance, General</i>.
G, Jan 1994	<ul style="list-style-type: none"> • Deleted references to mho characteristic. • Corrected Figure 4-3 (Sensing Input Test Setup), current sensing input terminals 8 and 9 were reversed on earlier versions; renumbered equations; updated format; and added new internal connection diagrams Figures 4-3 through 4-5, added new mounting diagrams Figures 4-6 through 4-14. • Added new Section 5, <i>Setting and Testing</i>, moved appropriate data from Section 4 into Section 5, and changed Section 5 and 6 to Section 6 and 7.
F, Jan 1991	<ul style="list-style-type: none"> • Pages 1-3, 1-5 (Style Chart), 1-7 2-1 (Item H), 4-4 (step 3), 4-7 (Step 3): Time delay range is 0.1 to 9.90 seconds, adjustable in increments of 0.1 seconds. This was previously unclear or (in some cases) erroneous. • Page 1-8: RFI specification added. • Pages 1-6, 5-1: minor editing.
E, Sep 1990	<ul style="list-style-type: none"> • Legend of Figure 3-2 corrected. • Page 3-1 (under "Phase Shift"): 68° was 52°.
D, Aug 1989	<ul style="list-style-type: none"> • Equations 4.1 through 4.4 put into standard form by removing negative sign from the angle theta.
C, Jun 1989	<ul style="list-style-type: none"> • Figure 3-2 corrected. • Equations on page 4-8 restated for clarification. • Arithmetical errors corrected in the example given on page 4-8. • Table 4-2 corrected. • Figure 4-3 was reformatted. • Figure 4-7 revised to clarify installation.
B, Nov 1988	<ul style="list-style-type: none"> • Minor corrections and editing.
A, Nov 1988	<ul style="list-style-type: none"> • Figure 3-3 added. • Editing changes made to clarify specifications. • Two articles added to Section 4, entitled, "Setting the Pickup" (page 4-5) and, "Relay Characteristic Verification" page 4-7.
—, Nov 1986	<ul style="list-style-type: none"> • Initial release

Contents

General Information	1-1
Controls and Indicators	2-1
Functional Description.....	3-1
Installation.....	4-1
Setting and Testing	5-1



1 • General Information

Loss of excitation protection is applied on nearly all synchronous generators. Reduced or complete loss of excitation can cause loss of synchronism, instability and, possibly, damage to the generator from overheating. Many modern excitation systems include minimum-excitation limiters to prevent underexcitation; however, loss of excitation protective relays are still applied as backup to these automatic controls. BE1-40Q Loss of Excitation Relays provide this protection by monitoring the field excitation (measuring the magnitude and direction of var flow) and tripping the generator before serious damage to the generator can occur.

Synchronous generators in parallel are normally operated in the overexcited (lagging) region, which allows generation of reactive power (vars). Although the field excitation may be safely adjusted to cause the generator to absorb vars (leading), this is usually avoided because stability is unreliable under this condition.

When field excitation is not sufficient to maintain the terminal voltage of an interconnected generator, the system will attempt to supply reactive power to excite the generator. If the system cannot supply the required vars, the weakened field may allow the rotor to slip poles during disturbances such as load changes or faults, causing loss of synchronism.

When the system can supply the necessary vars, the generator will act as an induction generator, drawing excitation from the system. The machine voltage will remain above the setting of undervoltage relays, but the current induced by the rotor slip will flow in the damper (amortisseur) windings. The excessive heating caused by the current flow reduces machine life exponentially.

Under either condition, BE1-40Q Relays will detect the increased vars at the generator terminals as a loss of excitation and trips the generator to prevent loss of synchronism or excessive heating within the generator.

Application

Capability Curves

Generator manufacturers supply capability curves that specify the operating limits of a particular machine (similar to those shown in Figure 1-1). The curves are derived from the heating characteristics that occur on the stator end iron, the stator winding, and the rotor winding. Plotted on the complex power plane, real power P (kW) is on the horizontal axis and reactive power Q (var) is on the vertical axis.

An additional limit is often included on these curves, as shown in Figure 1-2. Here, the steady state stability limit further defines the safe operating limit of the generator. If the stability limit is exceeded, an out-of-step condition can occur due to loss of synchronism.

BE1-40Q Operating Characteristics

BE1-40Q relay characteristics closely follow the generator capability curves. The response characteristic is represented by a line eight degrees from horizontal, placed above the most restrictive limit of normal operation. As shown in Figure 1-3, the attendant intercept of the line on the Q axis (at -0.4 per unit vars in this example) is used to establish the pickup of the relay. A front panel rotary switch is used to set the TAP setting. Refer to Section 5, *Setting and Testing*, for specific information on determining the pickup setting.

Time Delay

A time delay is included in BE1-40Q Relays to prevent misoperation for transient conditions such as power swings due to synchronizing or external fault clearing. A definite time delay of 0.1 to 9.9 seconds can be set on the front panel thumbwheels in increments of 0.1 second. Setting both thumbwheels to 0 causes an instantaneous trip signal to be sent when the TAP setting is exceeded. Refer to Section 5 for specific setting information.

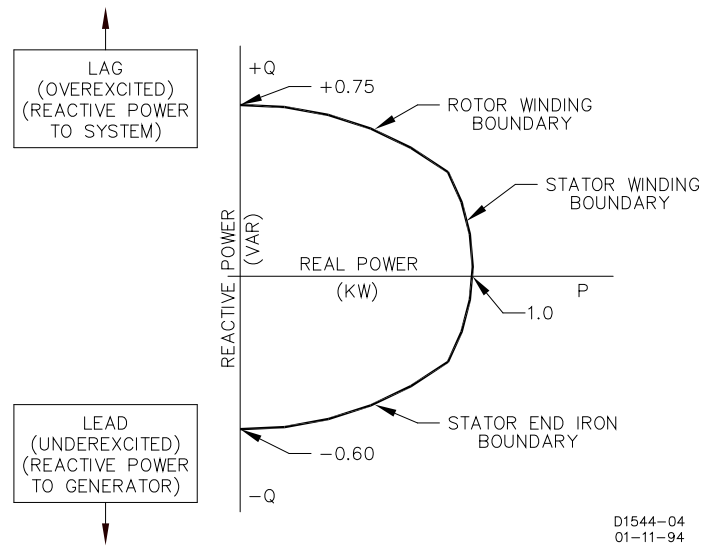

Figure 1-1. Typical Generator Capability Curve

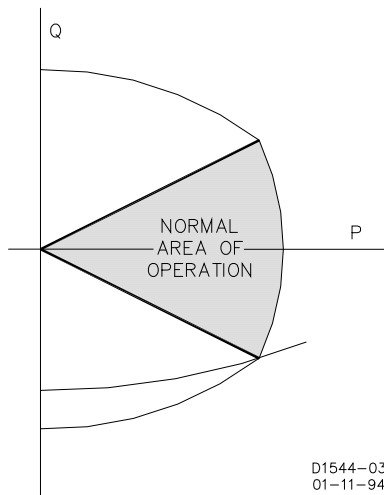

Figure 1-2. Normal Operation with Steady State Stability Limit

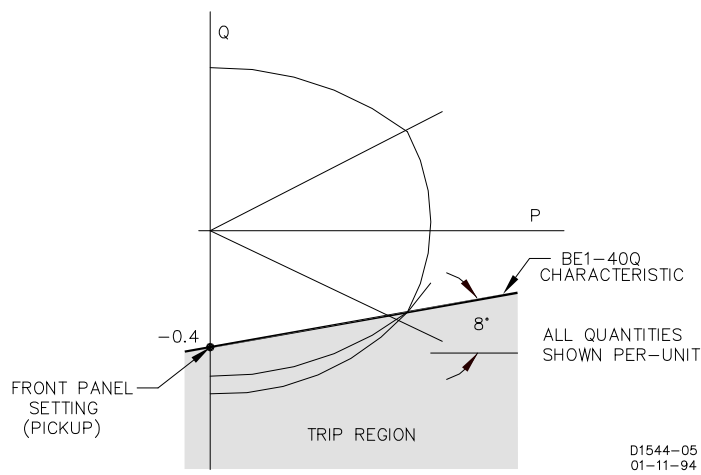
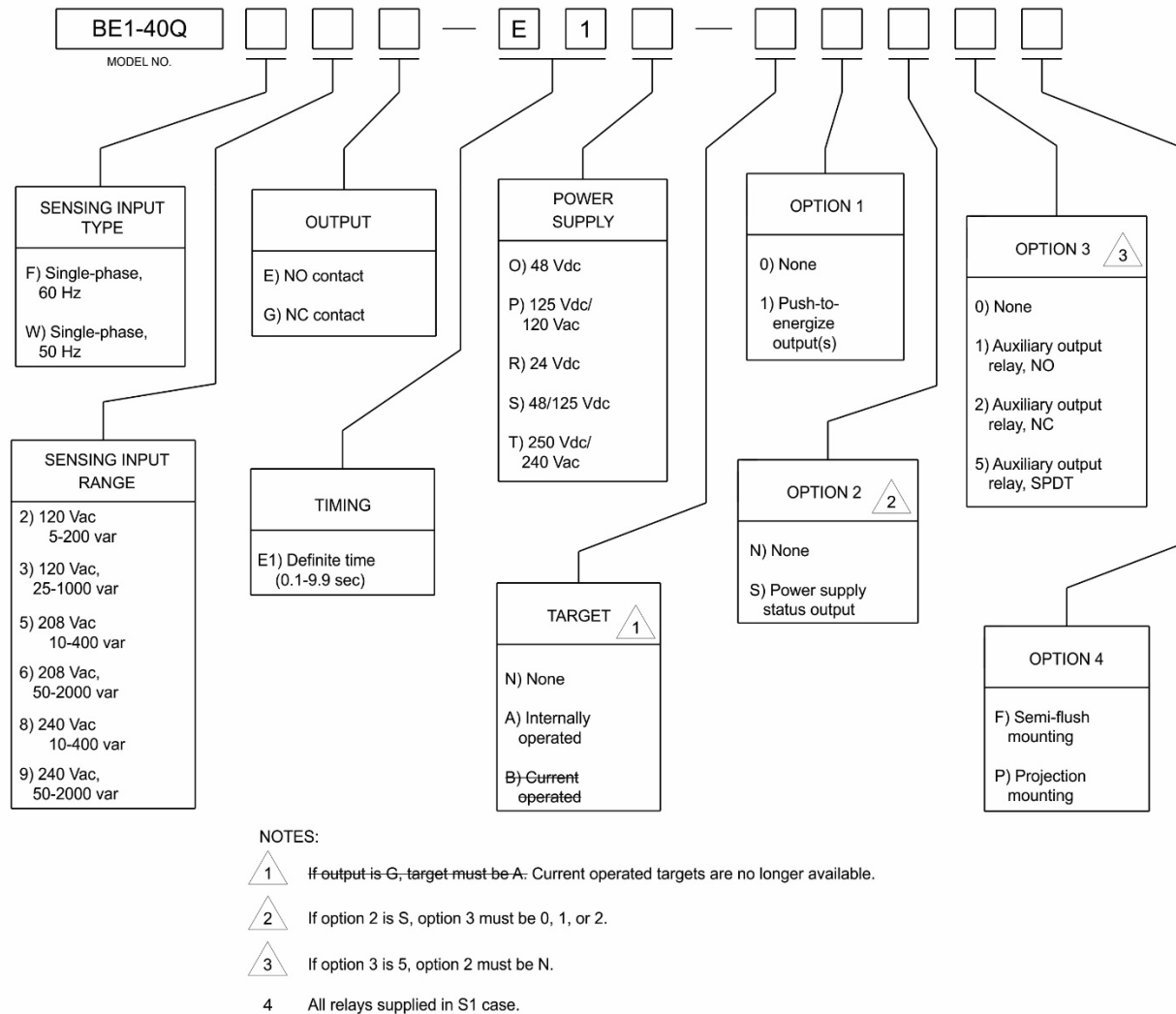

Figure 1-3. An example of BE1-40Q Relay Operating Characteristics

Model and Style Number

BE1-40Q electrical characteristics and operational features are defined by a combination of letters and numbers that make up the style number. Model number BE1-40Q designates the relay as a Basler Electric Loss of Excitation Relay. The model number, together with the style number, describes the options included in a specific device and appears on the front panel, draw-out cradle, and inside the case assembly.

The style number identification chart for the BE1-40Q relay is illustrated in Figure 1-4.



D2828-12

Figure 1-4. BE1-40Q Style Identification Chart

Style Number Example

If a BE1-40Q relay has a style number of **F3E-E10-B1S2F**, the relay has the following features:

F -----60 Hz single-phase current sensing

3 -----120 Vac, 25-1000 var

E -----One output relay with normally open contacts

- E1** -----Definite timing
O-----Operating power derived from 48 Vdc
A-----One internally operated target
1 -----Push-to-energize output
S -----Power supply status output
2 -----One auxiliary output relay with normally closed contacts
F -----Semi-flush mounting case

Specifications

BE1-40Q electrical and physical specifications are listed in the following paragraphs.

Current Sensing

Unit is designed to operate from the secondary of a standard current transformer rated at 5 A, 50 and 60 Hz (based on configuration). Internal current sensing transformers are rated at 10 A continuous, 15 A for 1 minute, and 200 A for 1 second.

Current Sensing Burden

Maximum sensing burden is less than 0.1 ohm at pickup over the frequency range of 45 to 65 Hz.

Voltage Sensing

Three line-to-line voltage sensing inputs are available: 120, 208, and 240 Vac (nominal). Each have a burden that is less than 1 VA over the frequency range of 45 to 65 Hz.

Pickup Range

Refer to Table 1-1.

Table 1-1. Pickup Ranges

Sensing Input Range	Tap	A	B	C	D	E	F	G	H	J	K
2 120 Vac	HI	20	40	60	80	100	120	140	160	180	200
	LOW	5.0	10	15	20	25	30	35	40	45	50
3 120 Vac	HI	100	200	300	400	500	600	700	800	900	1000
	LOW	25	50	75	100	125	150	175	200	225	250
5 208 Vac	HI	40	80	120	160	200	240	280	320	360	400
	LOW	10	20	30	40	50	60	70	80	90	100
6 208 Vac	HI	200	400	600	800	1000	1200	1400	1600	1800	2000
	LOW	50	100	150	200	250	300	350	400	450	500
8 240 Vac	HI	40	80	120	160	200	240	280	320	360	400
	LOW	10	20	30	40	50	60	70	80	90	100
9 240 Vac	HI	200	400	600	800	1000	1200	1400	1600	1800	2000
	LOW	50	100	150	200	250	300	350	400	450	500

Pickup Accuracy

±2% of the front panel setting or ±0.1 var, whichever is greater for a power factor angle of -90°.

Dropout

Not less than 95% of actual pickup.

Time Delay Range

Definite time delay is adjustable by two front panel thumbwheels over a range of 01 to 99 (0.1 to 9.9 seconds) in increments of 0.1 seconds. A setting of 00 enables instantaneous operation.

Timing Accuracy

Shown in Figure 1-5. Note that each curve is slightly offset by a factor that represents integration time. Repeatability is within $\pm 5\%$ or 50 milliseconds, whichever is greater.

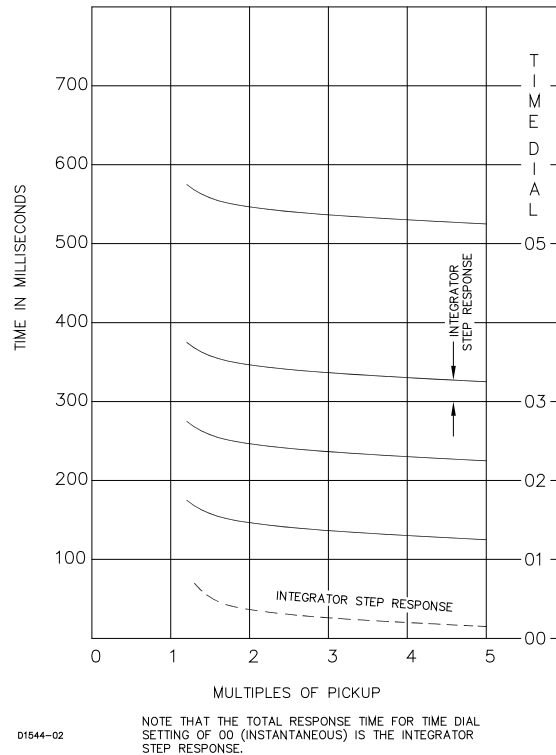

Figure 1-5. Typical Relay Response Time for Time Dial Settings

Output Contacts

Resistive Ratings

120 Vac:	Make, break, and carry 7 Aac continuously
250 Vdc:	Make and carry 30 Adc for 0.2 s, carry 7 Adc continuously, break 0.3 Adc
500 Vdc:	Make and carry 15 Adc for 0.2 s, carry 7 Adc continuously, break 0.3 Adc

Inductive Ratings

120 Vac, 125 Vdc, 250 Vdc:	Break 0.3 A (L/R = 0.04)
----------------------------	--------------------------

Power Supply

Power supply types and specifications are listed in Table 1-2.

Table 1-2. Power Supply Ratings

Type	Nominal Input Voltage	Input Voltage Range	Burden at Nominal
O (midrange)	48 Vdc	24 to 150 Vdc	1.9 W
P (midrange)	125 Vdc	24 to 150 Vdc	2.2 W
	120 Vac	90 to 132 Vac	18.4 VA
R (low range)	24 Vdc	12 to 32 Vdc *	1.9 W
S (midrange)	48 Vdc	24 to 150 Vdc	1.9 W
	125 Vdc	24 to 150 Vdc	2.2 W
T (high range)	250 Vdc	68 to 280 Vdc	2.3 W
	240 Vac	90 to 270 Vac	32.1 VA

* Type R power supply initially requires 14 Vdc to begin operating. Once operating, the input voltage may be reduced to 12 Vdc and operation will continue.

Target Indicator

An electronically latched, manually reset target indicator is optionally available to indicate closure of the trip output contact. Either an internally operated or a current operated target may be specified. An internally operated target should be selected when a normally closed (NC) output contact is specified.

Current Operated Target

Minimum Rating:	200 mA flowing through the trip circuit
Continuous Rating:	3 A
1 Second Rating:	30 A
2 Minute Rating:	7 A

Type Tests

Shock:	Withstands 15 G in each of three mutually perpendicular planes without structural damage or performance degradation.
Vibration:	Withstands 2 G in each of three mutually perpendicular planes, swept over the range of 10 to 500 Hz for a total of six sweeps, 15 minutes each sweep, without structural damage or degradation of performance.
Dielectric Strength:	Tested in accordance with IEC 255-5 and IEEE C37.90. All circuits to ground: 2,121 Vdc. Input to Output circuits: 1,500 Vac/2,121 Vdc.
Radio Frequency Interference:	Maintains proper operation when tested for interference in accordance with IEEE C37.90.2-1987, <i>Standard Withstand Capability of Relay Systems to Radiated Electromagnetic Interference from Transceivers</i> .
Surge Withstand Capability:	Qualified to IEEE C37.90.1-1989, <i>Standard Surge Withstand Capability (SWC) Tests for Protective Relays and Relay Systems</i> .

Physical

Temperature

Operating Range: -40 to 70°C (-40 to 158°F)
Storage Range: -65 to 100°C (-85 to 212°F)

Weight: 13.5 lb (6.12 kg)

Case Size: S1 (Refer to Section 4 for case dimensions.)

Agency Recognition/Certification

UL Recognition: UL recognized per Standard 508, File E97033
NOTE: Output contacts are not UL recognized for voltages greater than 250 volts.



2 • Controls and Indicators

All BE1-40Q controls and indicators are located on the front panel. The controls and indicators are shown in Figure 2-1 and described in Table 2-1. Figure 2-1 illustrates a relay with the maximum number of controls and indicators. Your relay may not have all of the controls and indicators shown and described here.

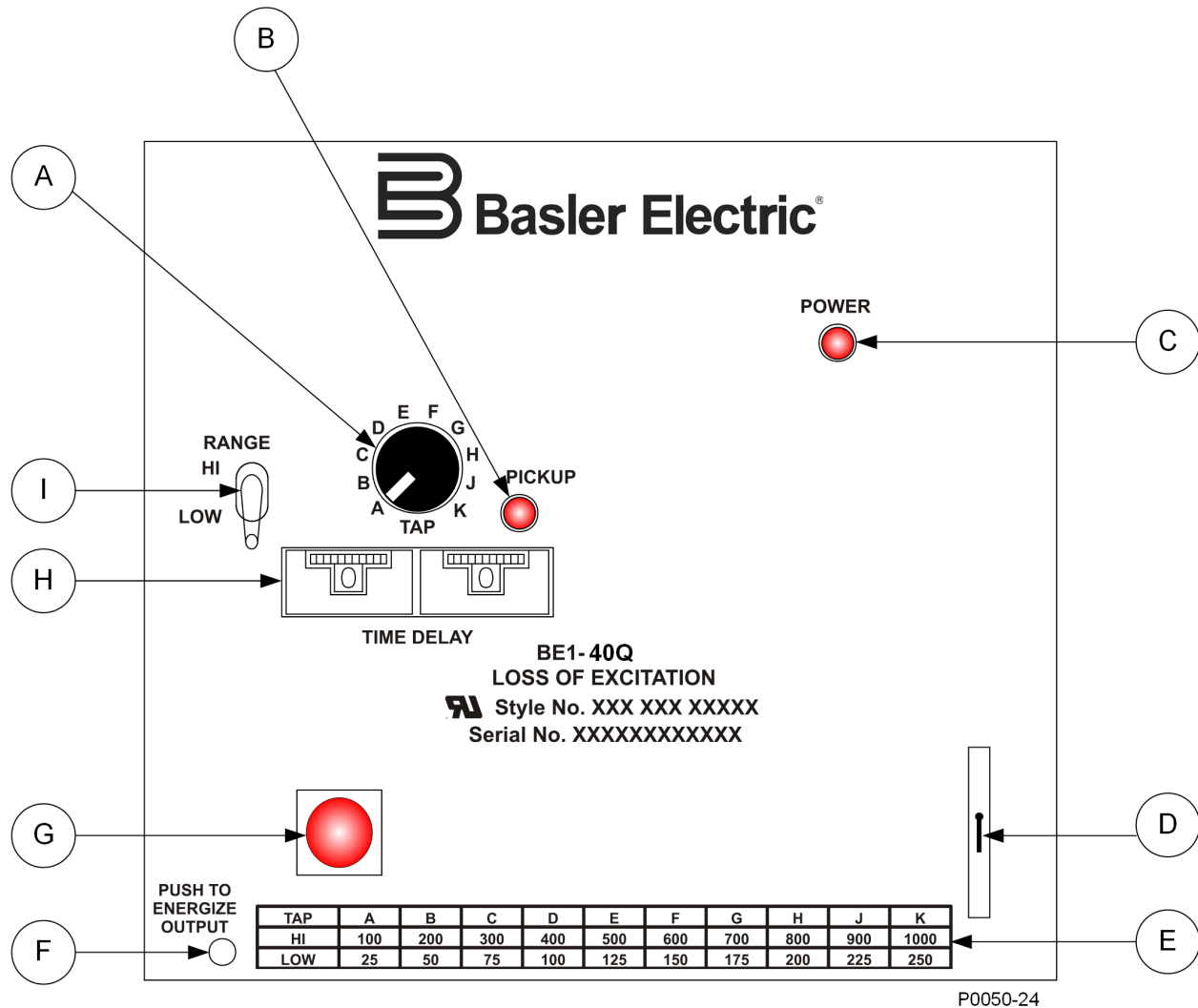

Figure 2-1. BE1-40Q Controls and Indicators

Table 2-1. Control and Indicator Descriptions

Locator	Description
A	<i>Tap Switch.</i> A ten-position rotary switch sets the pickup point when used in conjunction with the Range switch (see Locator I). Pickup levels (in vars) are labeled on the Tap Range Chart (see Locator E).
B	<i>Pickup Indicator.</i> LED illuminates to indicate that the pickup level has been exceeded.
C	<i>Power Indicator.</i> This red LED lights when operating power is applied to the relay.
D	<i>Target Reset Switch.</i> This switch is operated to reset the target indicator.

Locator	Description
E	<i>Tap Range Chart.</i> Provides an index of reactive power levels (in vars) that correspond to the Tap switch positions.
F	<i>Output Test Pushbutton.</i> This pushbutton allows manual actuation of the output relay. Output relay actuation is achieved by inserting a nonconductive rod through the front panel access hole.
G	<i>Target Indicator.</i> The electronically latched red target indicator illuminates when the corresponding output relay energizes. To ensure proper operation of the current-operated target, the current flowing through the trip circuit must be 200 mA or higher. The target indicator is reset by operating the target reset switch (locator D).
H	<i>Time Delay Selectors.</i> Two thumbwheel switches select the trip time delay. The left thumbwheel represents seconds; the right thumbwheel represents tenths of a second.
I	<i>Range Switch.</i> Two-position switch selects the reactive power range (HI or LOW) desired.

3 • Functional Description

BE1-40Q Loss of Excitation relays are static devices that respond to the relation of voltage to current magnitudes of the monitored circuit. As such, they are sensitive to phase rotation. All connections shown in this manual assume ABC rotation. BE1-40Q relay functions are illustrated in Figure 3-1 and described in the following paragraphs.

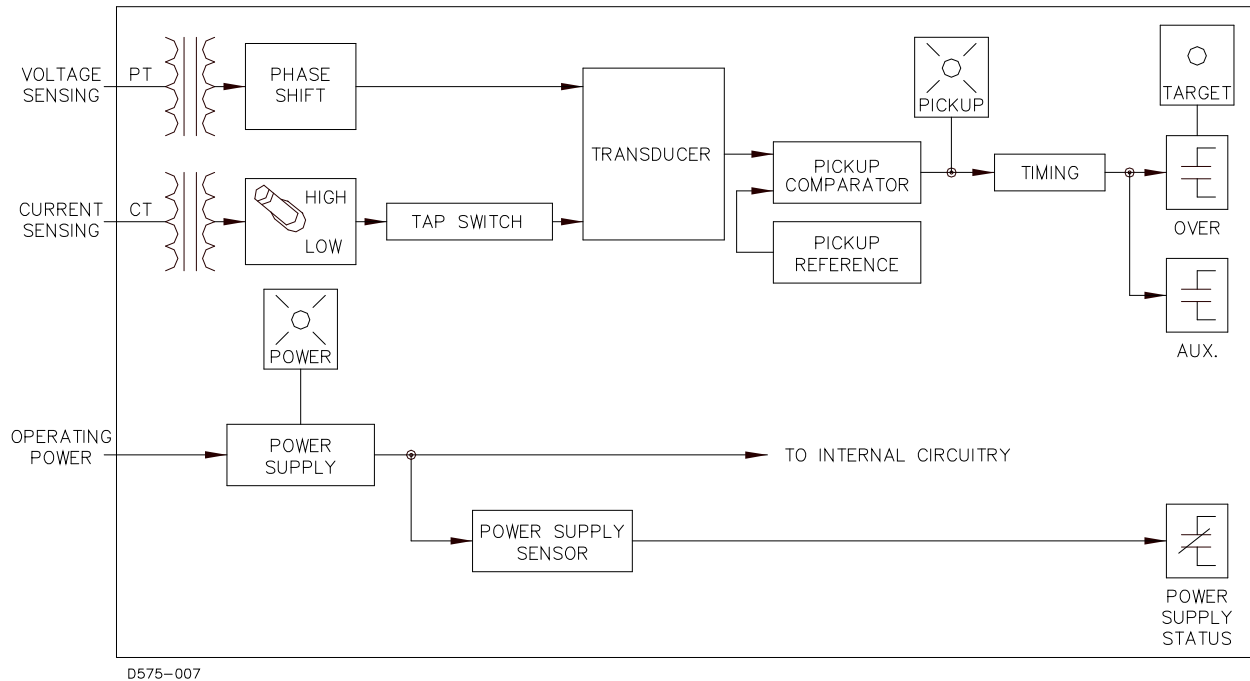

Figure 3-1. Function Block Diagram

Voltage Sensing

The monitored voltage input is derived from a system voltage transformer connected phase-to-phase. An internal voltage transformer (PT) provides isolation and reduces the nominal value of the voltage sensing input (i.e., 120, 208, or 240 Vac) to internal circuitry requirements.

Phase Shift

Since the voltage input, V_{AB} , leads the sensed input current, I_B , by an angle of 150° for a unity power factor condition, the voltage phasor is internally shifted 68° in a lagging direction (delayed) to achieve the relay response characteristics. The resultant I_{TRIP} leads the polarizing voltage V_{POL} by 8° (when the system power factor angle (θ) is equal to -90° as shown in Figure 3-2).

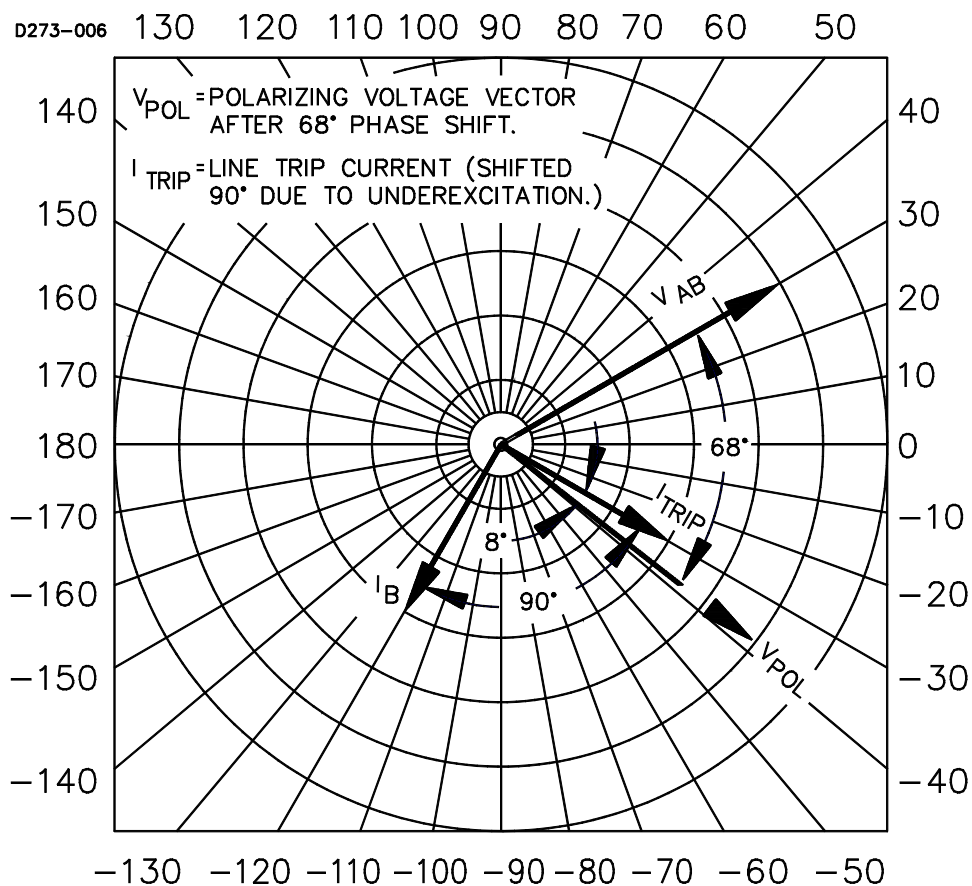

Figure 3-2. Phase Shift Example

The response of the relay is:

$$\text{Front Panel Pickup Setting} = \left(\frac{V_{AB}(I_B)}{\sqrt{3}} \right) \left(\frac{\sin(8^\circ - \emptyset)}{\cos 8^\circ} \right)$$

Or

$$I_B = \left(\frac{\text{Front Panel Pickup Setting}}{V_{AB}} \right) \left(\frac{\sqrt{3} \cos 8^\circ}{\sin(8^\circ - \emptyset)} \right)$$

Where:

V_{AB} = phase A to phase B voltage magnitude

I_B = phase B current magnitude

\emptyset = system power factor angle = (voltage angle) – (current angle)

Current Sensing

The monitored current is derived from the secondary of a system current transformer rated nominal five amperes. An internal current transformer (CT) provides isolation and scaling for proper relay operation. The front panel HI/LOW RANGE switch uses the tapped secondary of the internal CT for range selection to increase pickup stability.

Note that when the connection plugs (paddles) are removed, the CT inputs are shorted.

HI/LOW Range Switch

The front panel HI/LOW RANGE switch selects which secondary winding of the internal CT is connected to the TAP switch and thus the measurement circuitry. The position of this switch may be changed while sensing current is present. The effect of this switch, in conjunction with the TAP switch, is shown in the *Specifications*, Table 1-1, and on the front panel tap range chart.

Tap Switch

The front panel TAP switch selects the pickup setting (in single-phase vars), depending on the position of the HI/LOW RANGE switch, as shown in Table 1-1. The TAP switch selects the resistive burden value that is placed across the output of the internal sensing input CT. The resistive burden establishes the scaling of the internal signal that represents the input current value.

Transducer

The transducer consists of a multiplier and integrator. The multiplier and associated control circuits produce an output that is representative of the product of the scaled current input and the scaled, phase-shifted voltage input signal. The output waveform of the multiplier is an instantaneous value; therefore, the output is integrated to develop a signal that represents the average var value. The integrator response time is a function of the pickup multiple, as shown in Section 1, *Specifications*.

Comparator

The signal representing the single-phase var value is compared with the pickup reference. When the reference value is exceeded, the PICKUP LED indicator is illuminated and timing is initiated.

Timing

A definite time delay is initiated when the monitored var level exceeds the pickup reference. A calibrated frequency generating circuit, in conjunction with counter circuits and the front panel TIME DELAY thumbwheel switches, establishes the definite time delay interval.

Time delay is adjustable from 0.1 to 9.9 seconds in 0.1-second intervals. A setting of 00 enables instantaneous (no intentional time delay) operation. Timing is instantaneously reset if the var level reduces to less than the pickup setting.

For a complete description of timing accuracy, refer to *Specifications* in Section 1.

Outputs

Defined by the style number, the output relay may have either a normally open (NO) or normally closed (NC) configuration. The normally open output contact option is required when a current operated target is desired.

In addition, an auxiliary output contact may be provided which is specified by style number as NO, NC, or SPDT. If an auxiliary contact is provided, then the power supply status output is not available.

Push-To-Energize Output Pushbutton

A small pushbutton switch may be provided as an option to allow testing the primary output contact and (if present) the auxiliary output contact. To prevent accidental operation, the pushbutton is recessed behind the front panel and is depressed by inserting a thin, non-conducting rod through an access hole in the front panel.

Power Supply Status Output

The power supply status relay has a set of normally closed contacts and energizes when operating power is applied to the BE1-40Q. If relay operating power is lost or either side of the power supply output (+12 Vdc or -12 Vdc) fails, the power supply status relay de-energizes and opens the power supply status output contacts.

Power Supply

Operating power for the relay circuitry is supplied by a wide range, electrically isolated, low-burden power supply. Power supply operating power is not polarity sensitive. The front panel power LED and power supply status output indicate when the power supply is operating. Power supply specifications are listed in Table 1-1.

Target Indicator

A target indicator is an optional component selected when a relay is ordered. The electronically latched and reset target consists of a red LED indicator located on the relay front panel. A latched target is reset by operating the target reset switch on the front panel. If relay operating power is lost, an illuminated (latched) target is extinguished. When relay operating power is restored, the previously latched target is restored to its latched state.

A relay can be equipped with either an internally operated target or current operated target.

Internally Operated Target

The relay trip output is directly applied to drive the target indicator. The indicator is illuminated regardless of the current level in the trip circuit.

Current Operated Target

A current operated target is triggered by closure of the output contact and the presence of at least 200 milliamperes of current flowing in the trip circuit.

Note
Prior to September 2007, BE1-40Q the target indicator consisted of a magnetically latched, disc indicator. This mechanically latched target indicator has been replaced by the electronically latched LED target in use today.

4 • Installation

BE1-40Q relays are shipped in sturdy cartons to prevent damage during transit. Upon receipt of a relay, check the model and style number against the requisition and packing list to see that they agree. Inspect the relay for shipping damage. If there is evidence of damage, file a claim with the carrier, and notify your sales representative or Basler Electric.

If the relay will not be installed immediately, store it in its original shipping carton in a moisture- and dust-free environment. Before placing the relay in service, it is recommended that the test procedures of Section 5, *Setting and Testing* be performed.

Relay Operating Guidelines and Precautions

Before installing or operating the relay, note the following guidelines and precautions.

- For proper current operated target operation, a minimum current of 200 milliamperes must flow through the output trip circuit.
- If a wiring insulation test is required, remove the connection plugs and withdraw the relay from its case.

Caution

When the connection plugs are removed, the relay is disconnected from the operating circuit and will not provide system protection. Always be sure that external operating (monitored) conditions are stable before removing a relay for inspection, test, or service.

Notes

Be sure that the relay is hard-wired to earth ground with no smaller than 12 AWG copper wire attached to the ground terminal on the rear of the case. When the relay is configured in a system with other devices, it is recommended to use a separate lead to the ground bus from each device.

It is recommended in all applications where contact outputs drive relay coils that a reverse biased diode be implemented in parallel with the relay coil for EMI suppression.

Mounting

Because the relay is of solid-state design, it does not have to be mounted vertically. Any convenient mounting angle may be chosen. Relay outline dimensions and panel drilling diagrams are illustrated in Figures 4-1 through 4-12.

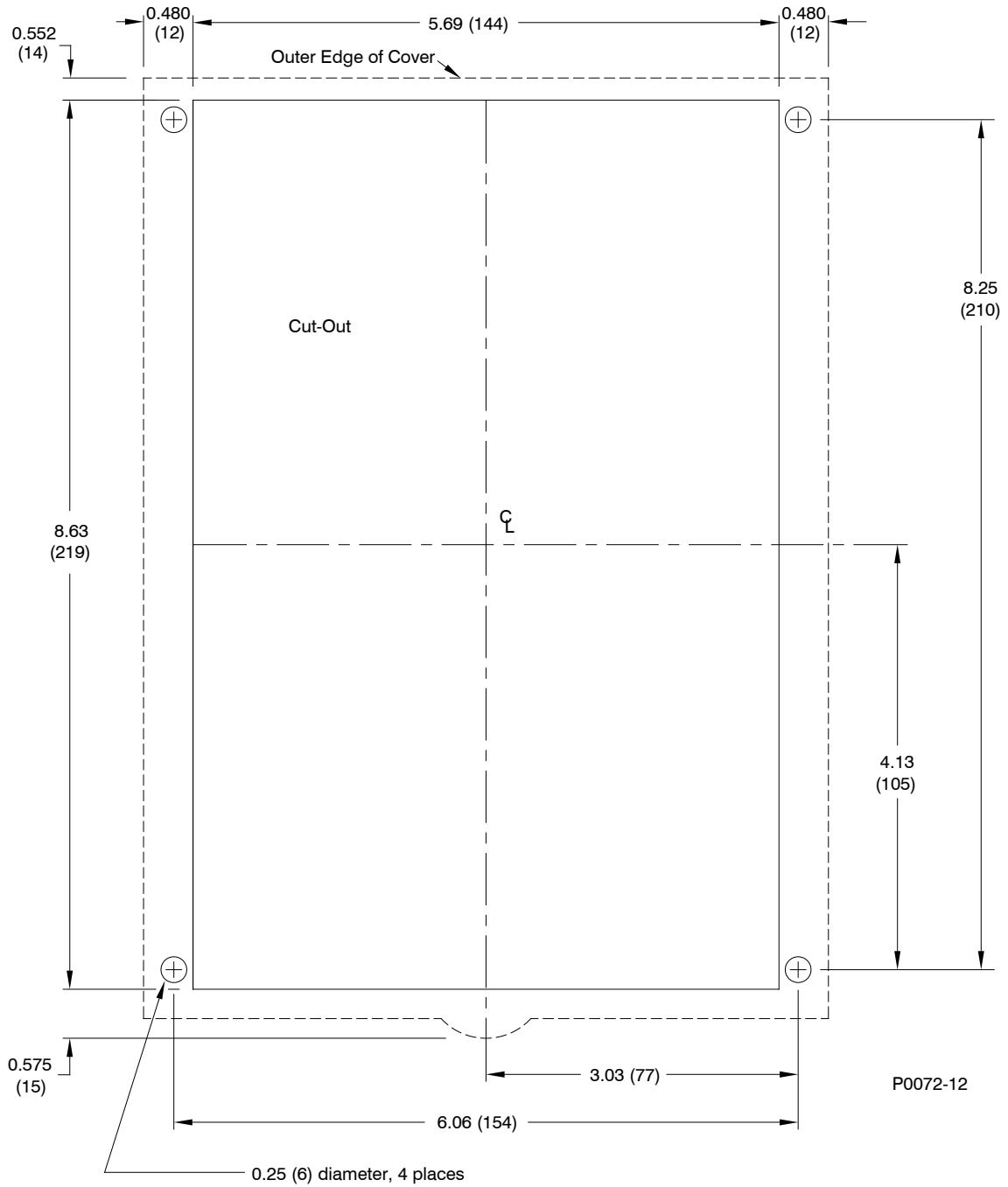

Figure 4-1. Panel Cutting/Drilling, Semi-Flush, S1 Case

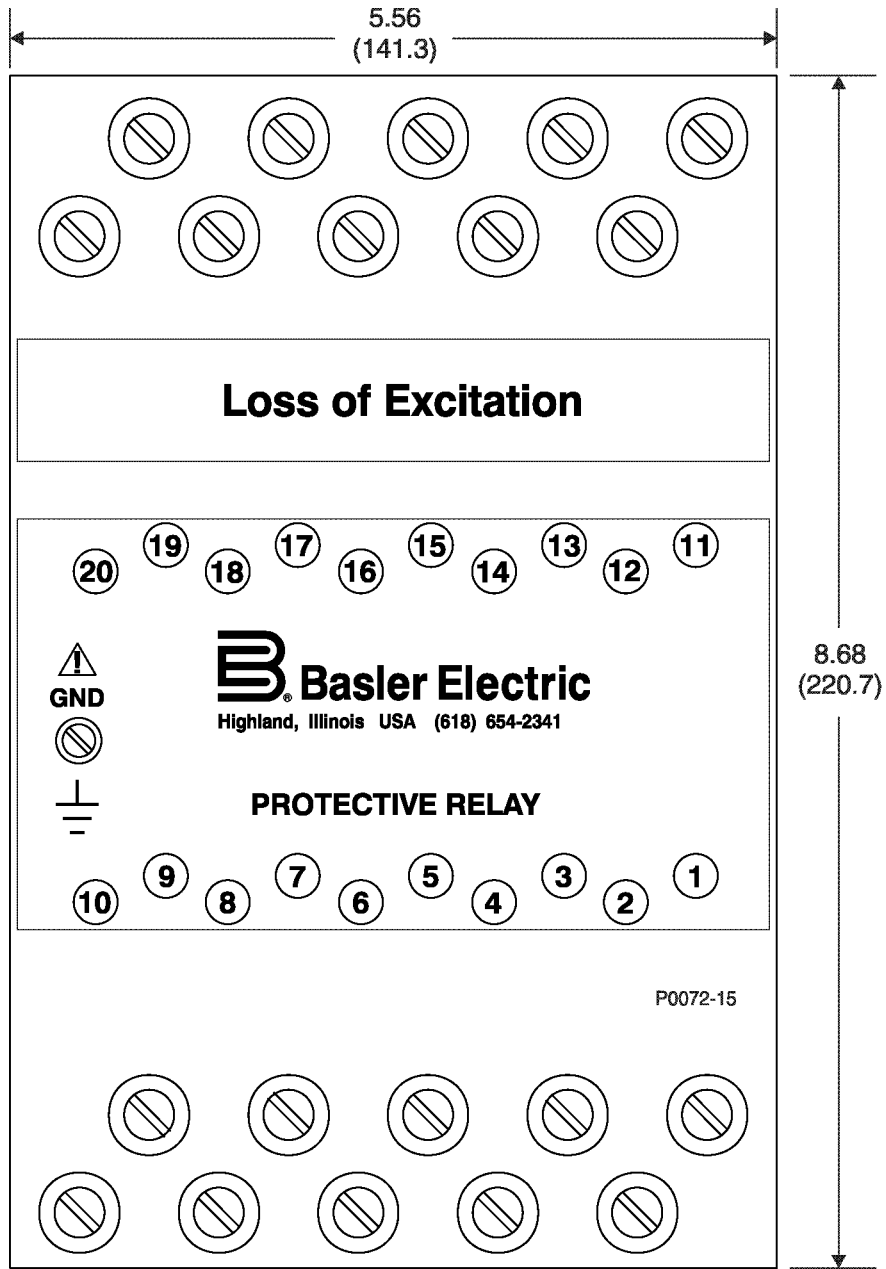

Figure 4-2. S1 Case Dimensions, Rear View, Double Ended, Semi-Flush Mount

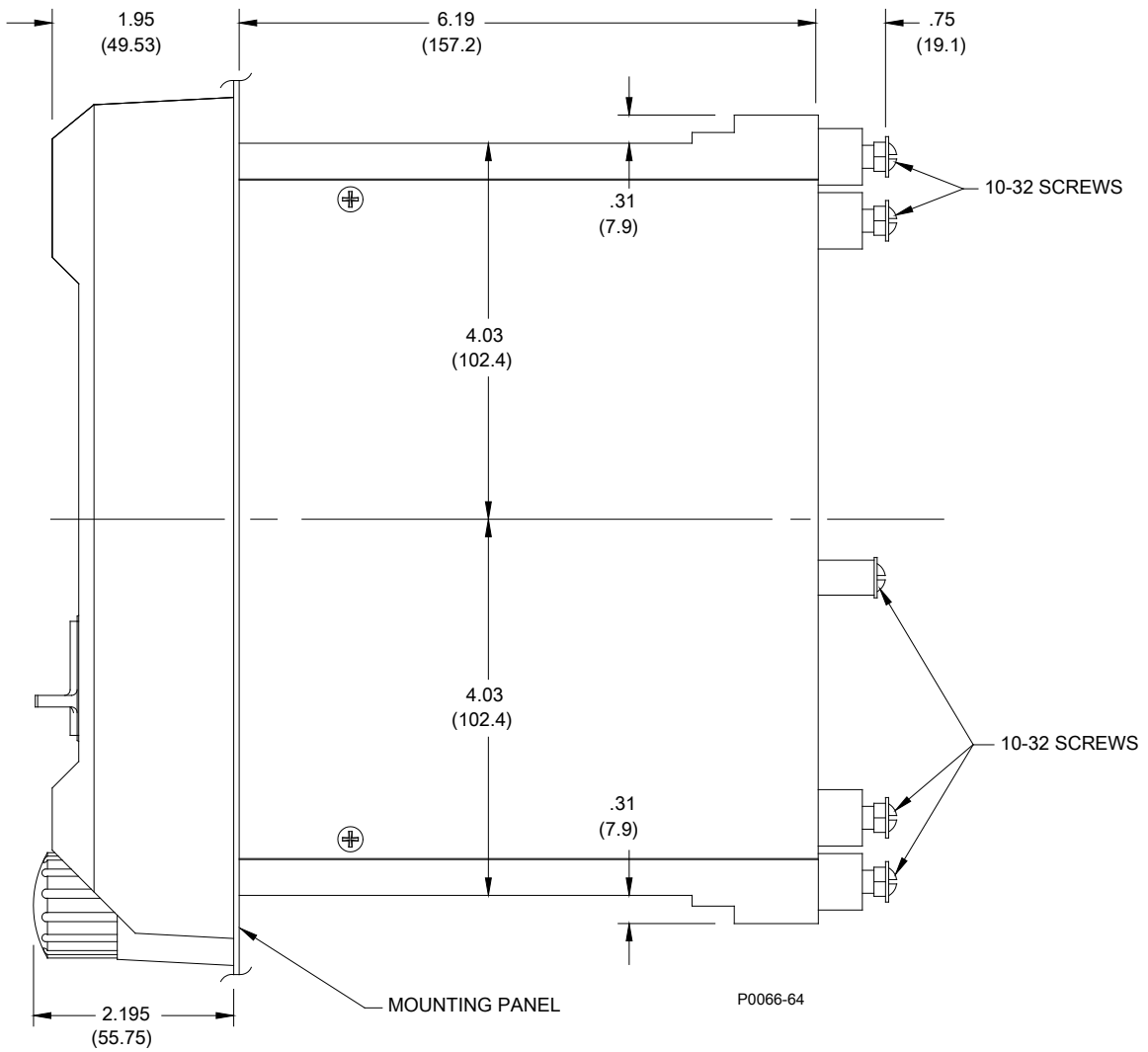

Figure 4-3. S1 Case Dimensions, Side View, Double Ended, Semi-Flush Mount

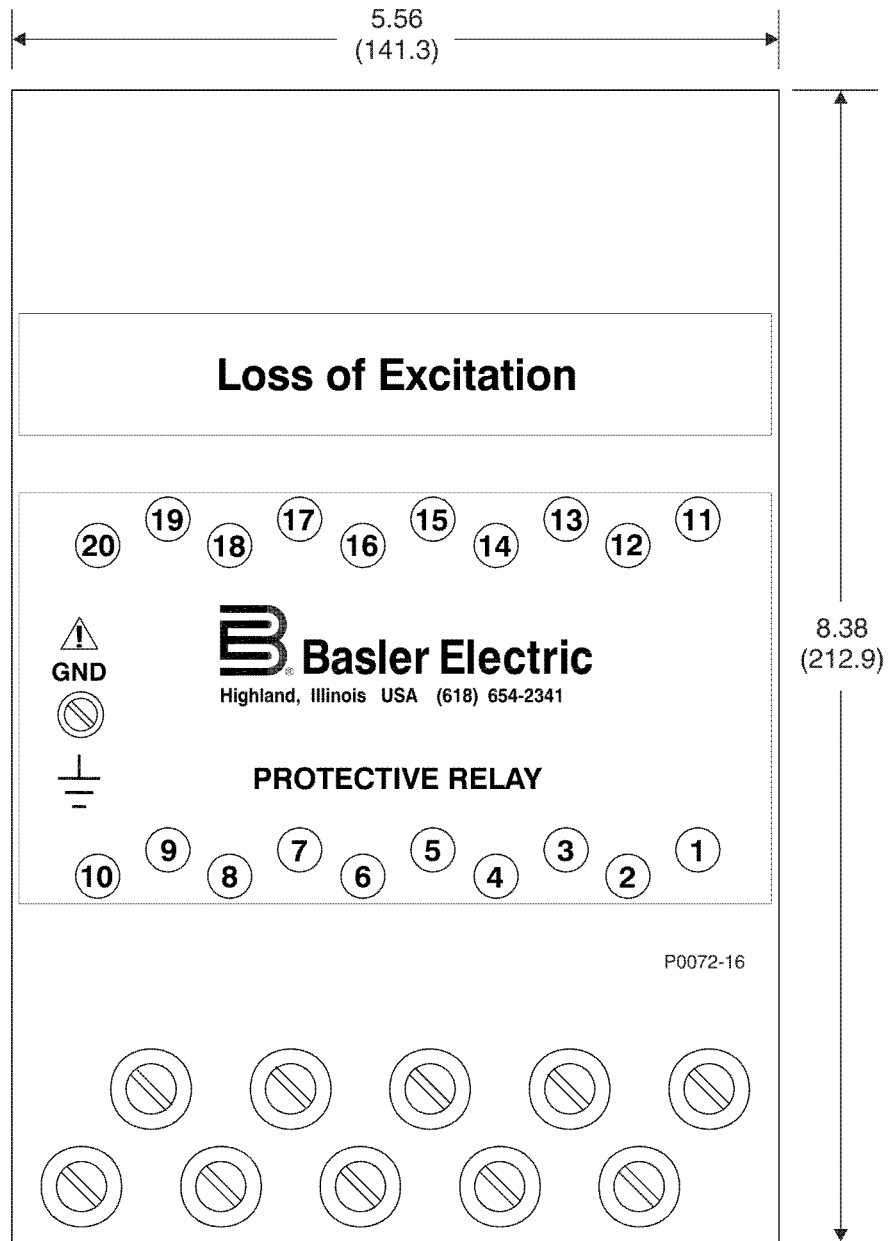

Figure 4-4. S1 Case Dimensions, Rear View, Single Ended, Semi-Flush Mount

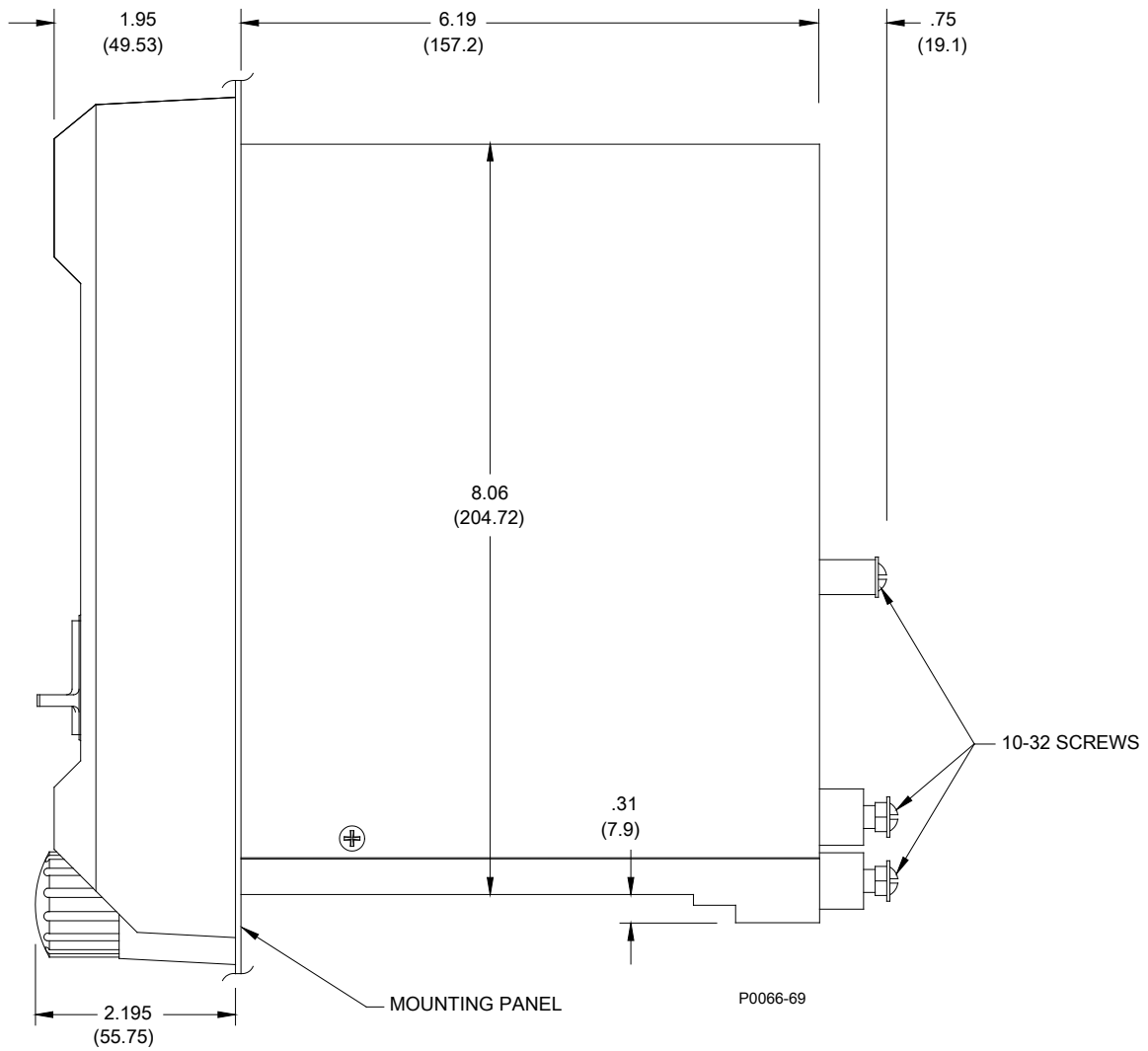

Figure 4-5. S1 Case Dimensions, Side View, Single Ended, Semi-Flush Mount

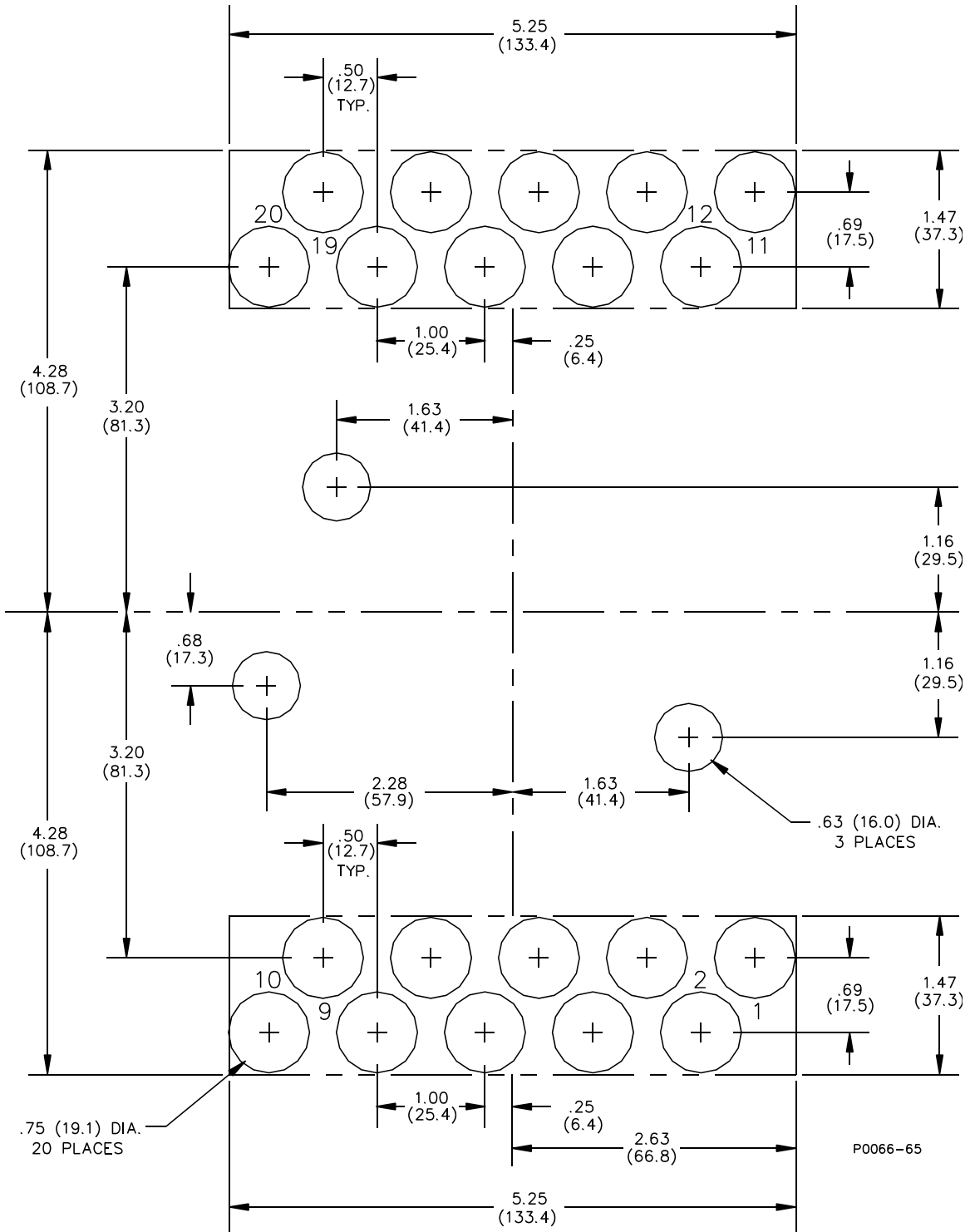

Figure 4-6. Panel Cutting/Drilling, Double Ended, Projection Mount, S1 Case

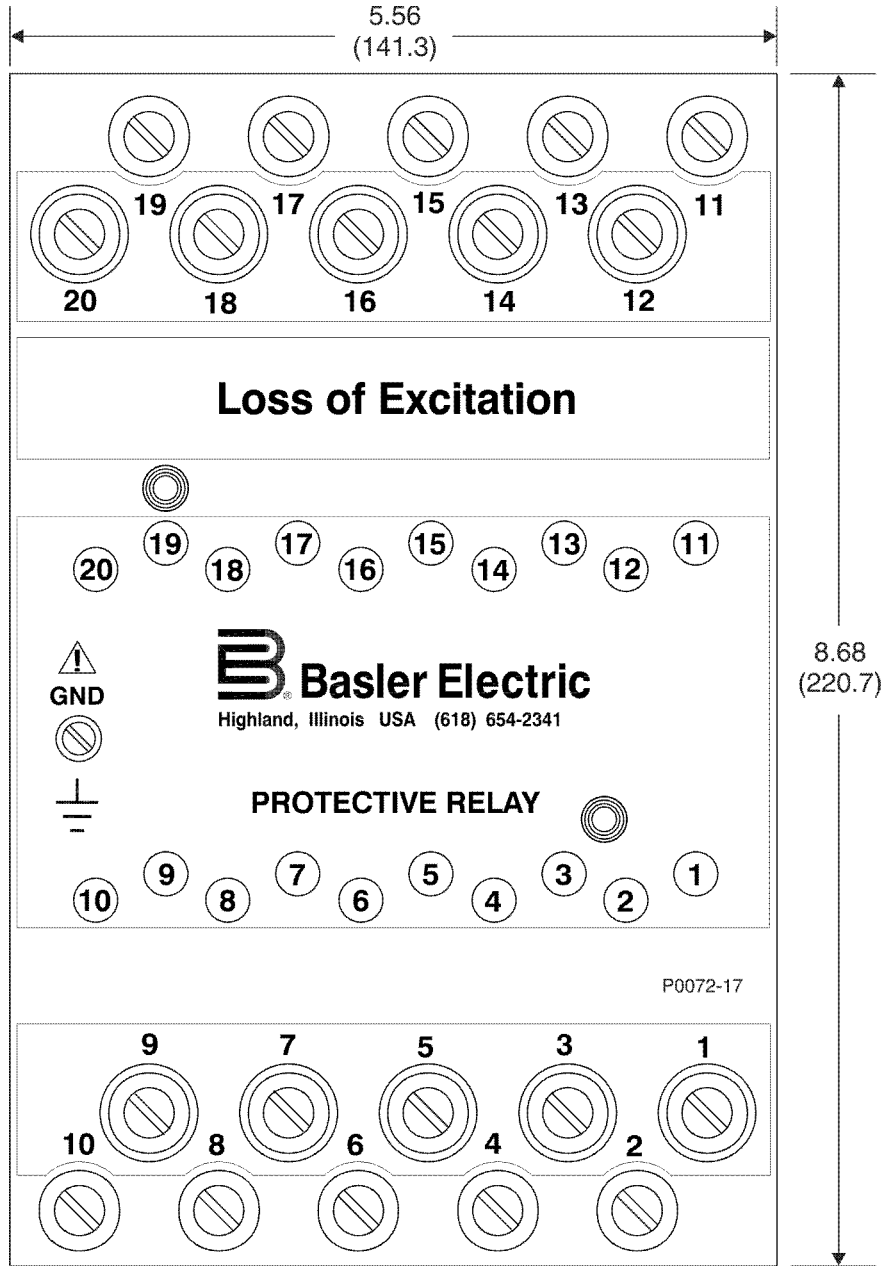

Figure 4-7. S1 Case Dimensions, Rear View, Double Ended, Projection Mount

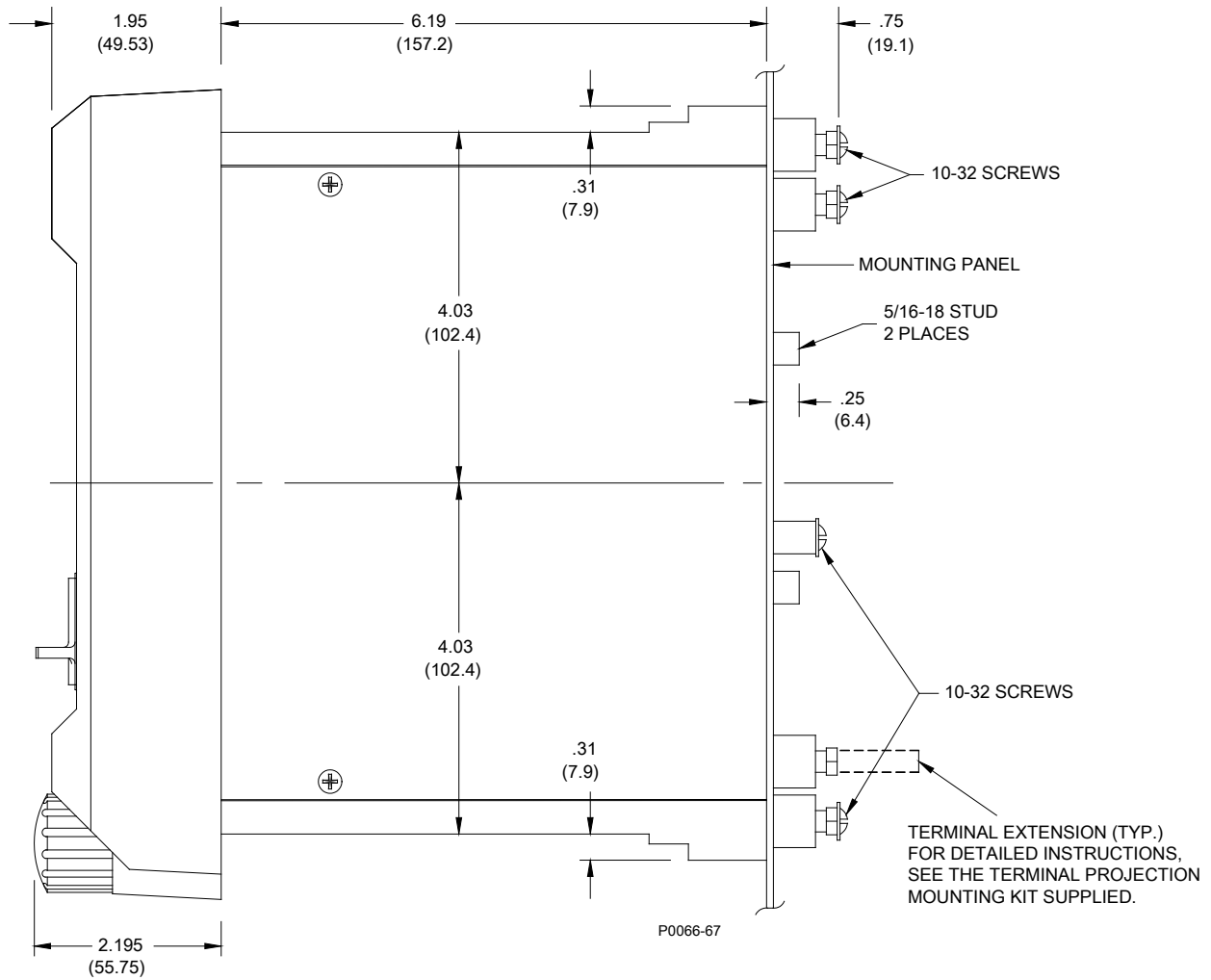

Figure 4-8. S1 Case Dimensions, Side View, Double Ended, Projection Mount

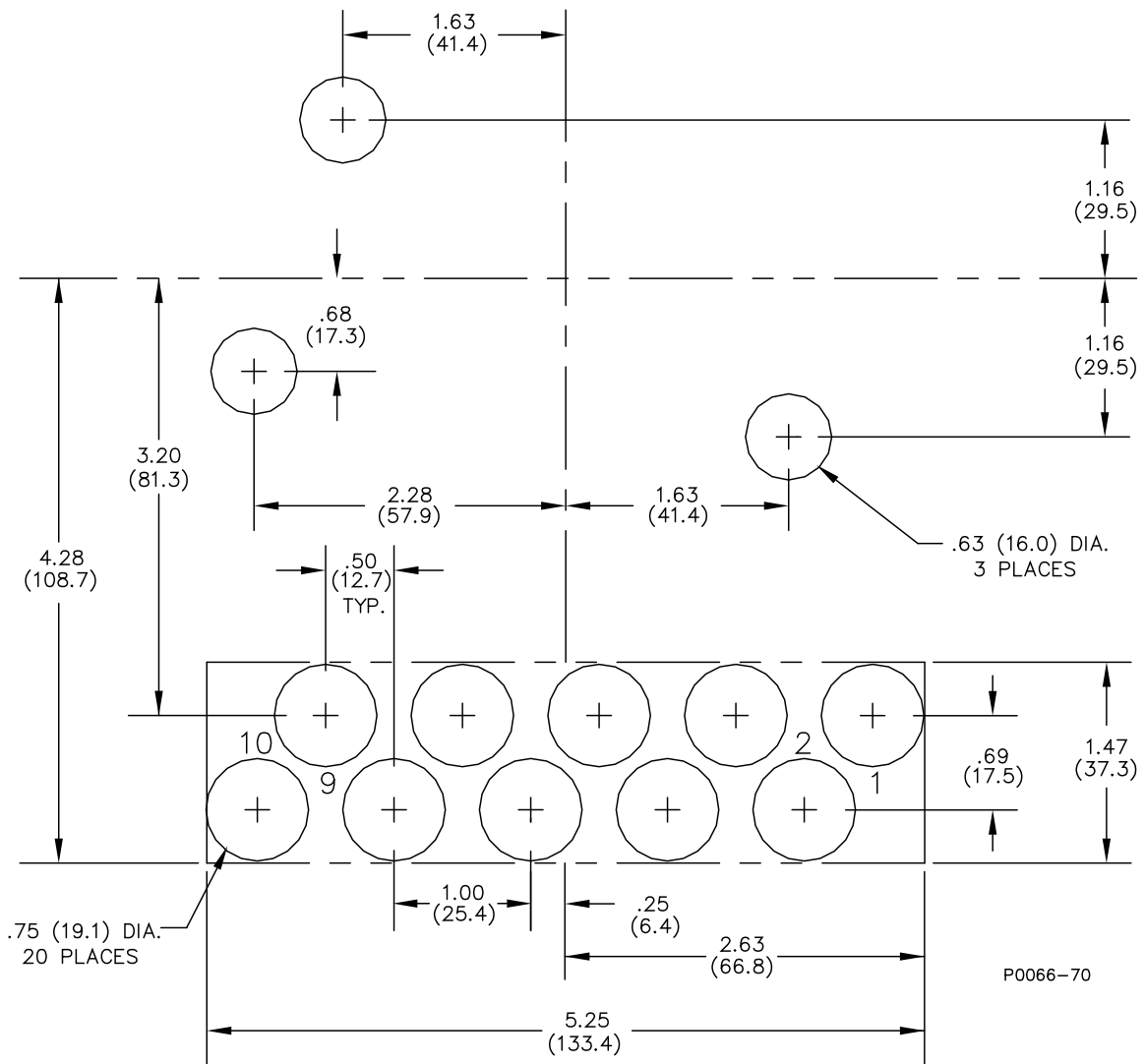

Figure 4-9. Panel Cutting/Drilling, Single Ended, Projection Mount, S1 Case

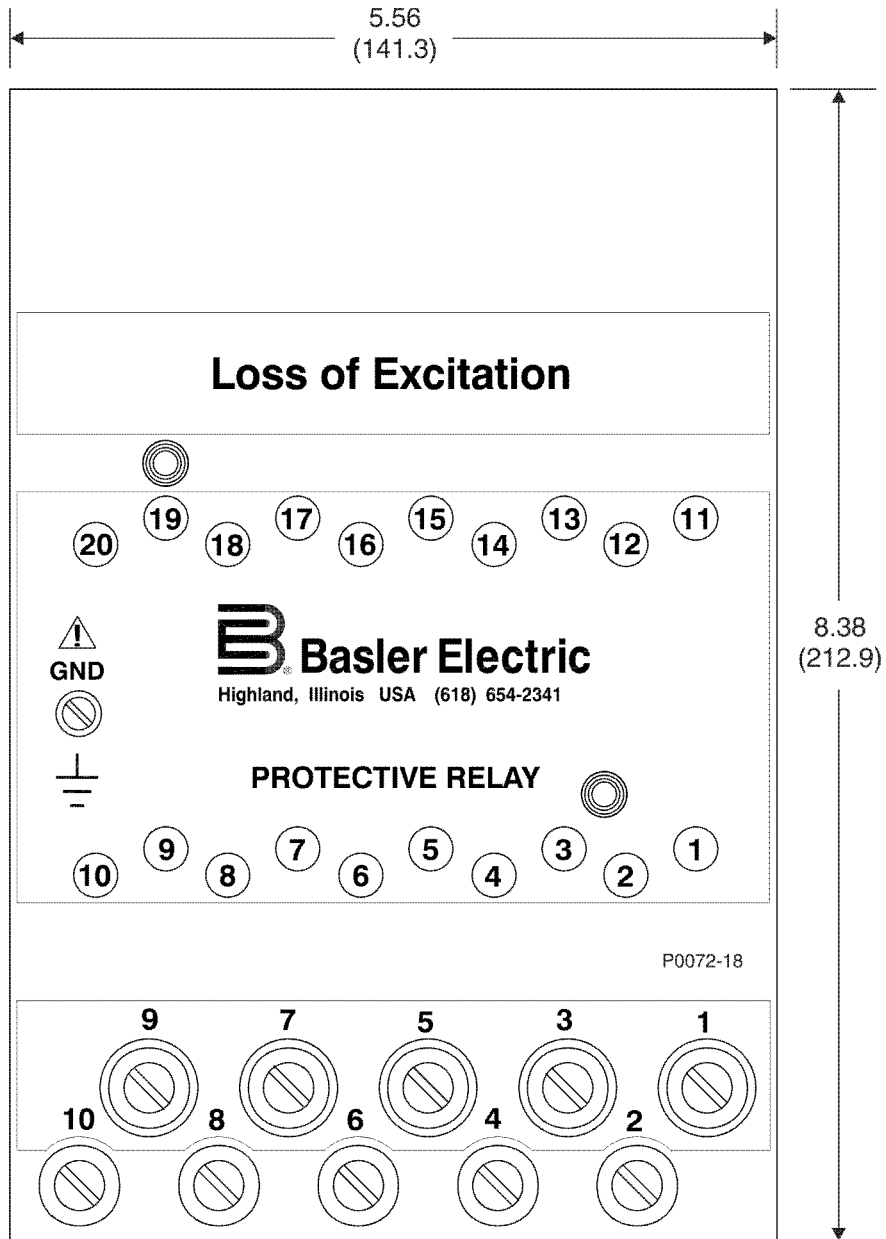

Figure 4-10. S1 Case Dimensions, Rear View, Single Ended, Projection Mount

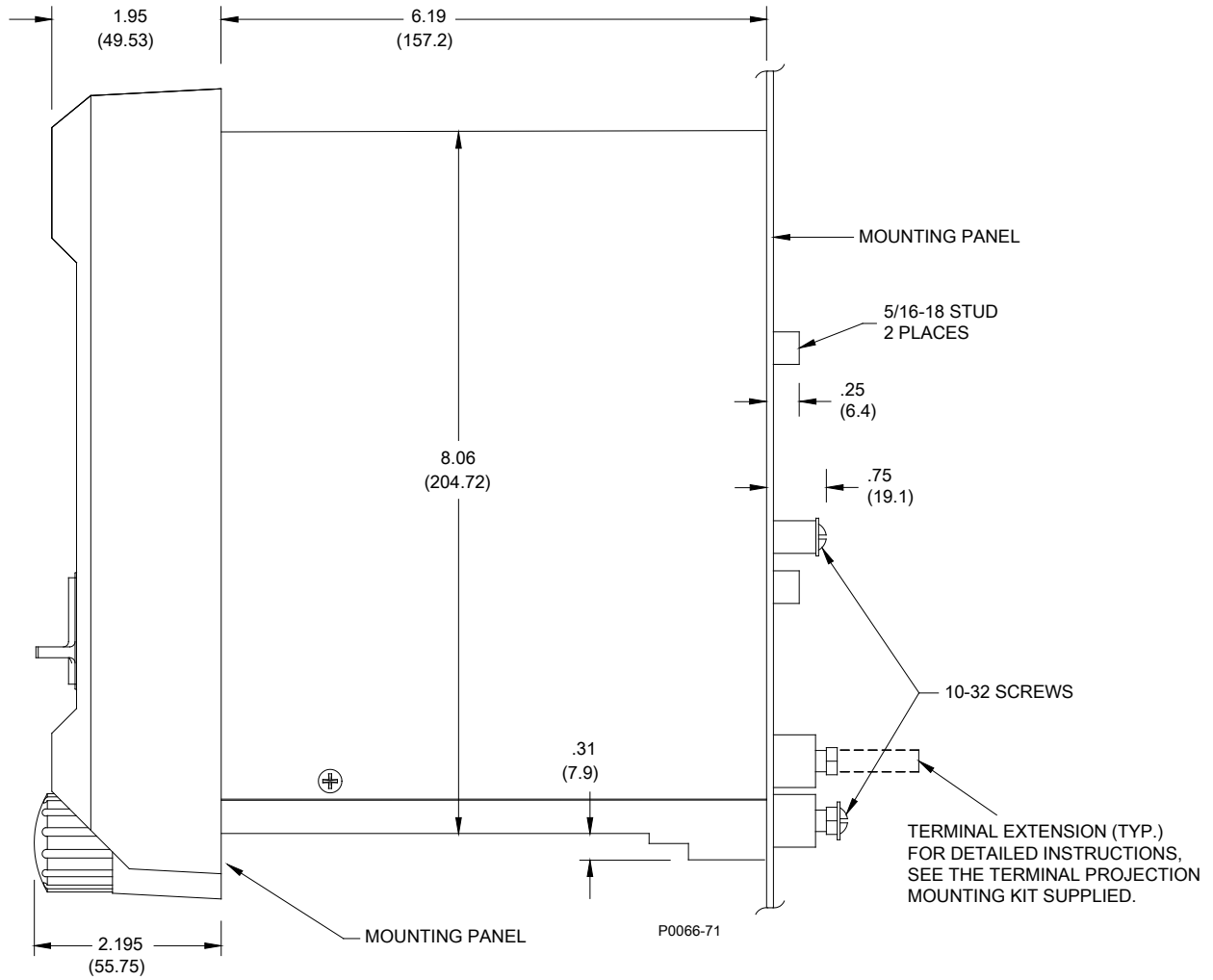

Figure 4-11. S1 Case Dimensions, Side View, Single Ended, Projection Mount

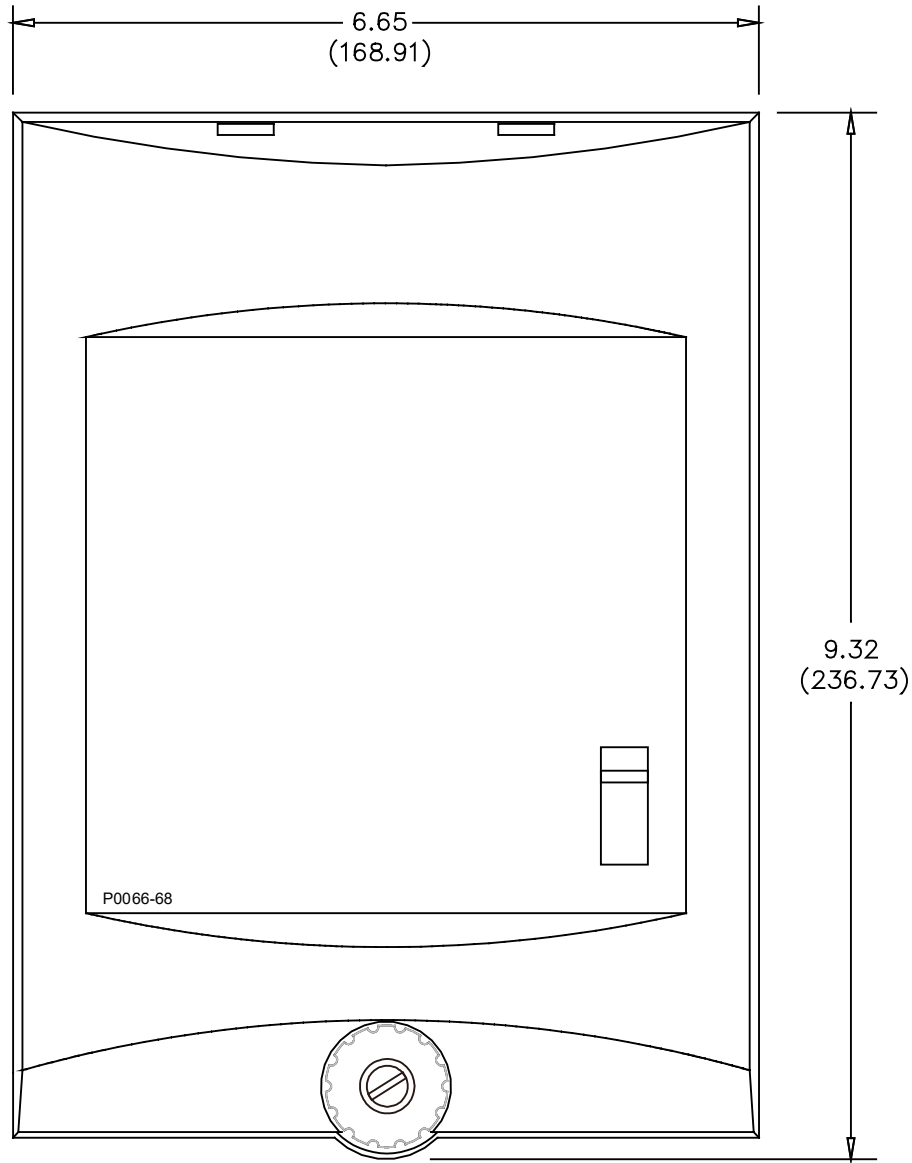

Figure 4-12. S1 Case Cover Dimensions, Front View

Connections

Be sure to check the model and style number of a relay before connecting and energizing the relay. Incorrect wiring may result in damage to the relay. Except where noted, connections should be made with wire no smaller than 14 AWG.

Typical sensing input connections are shown in Figure 4-13. Typical output connections are shown in Figure 4-14. Internal wiring diagrams are shown in Figures 4-15 through 4-16. All connections shown in this manual assume ABC rotation.

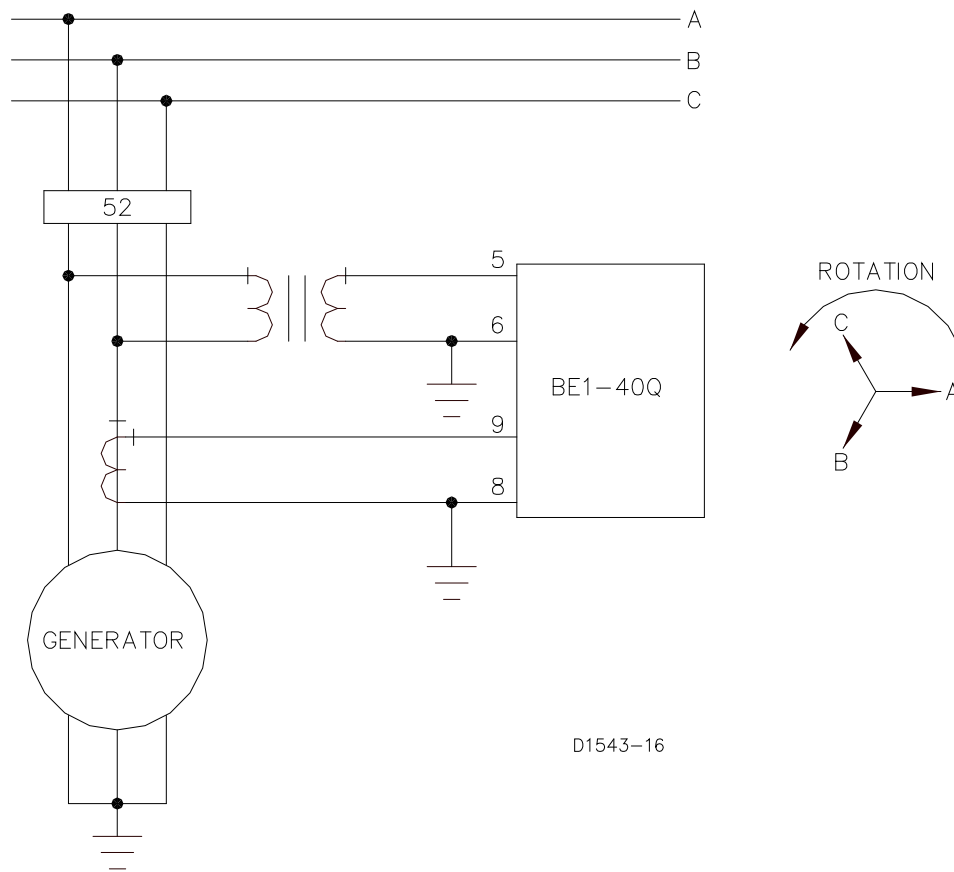
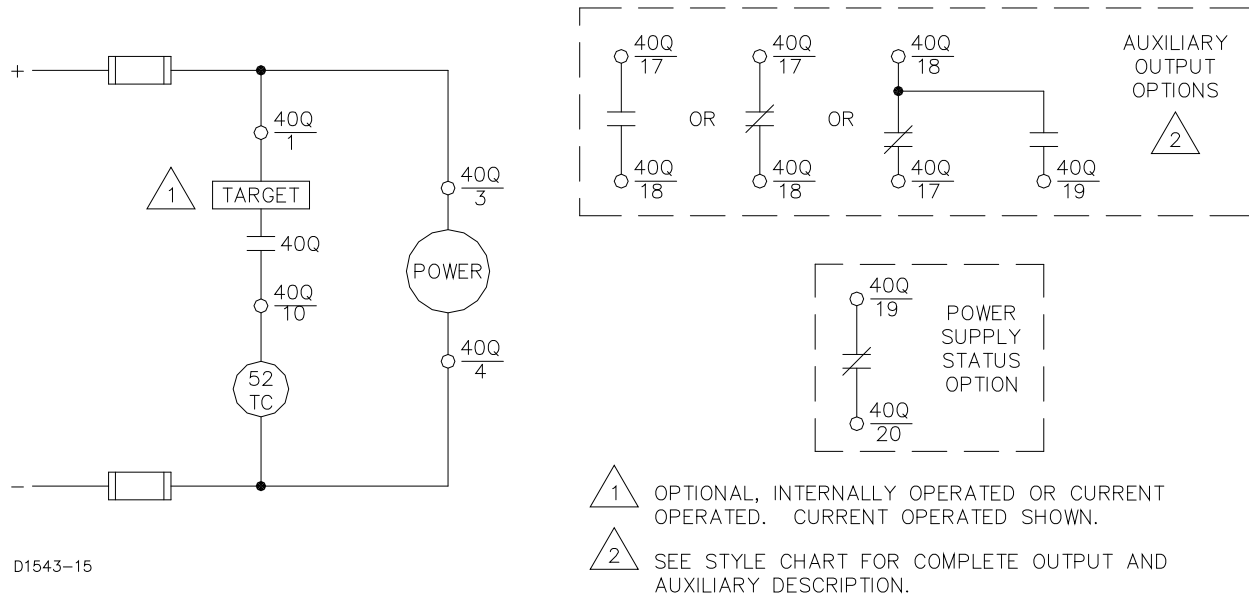

Figure 4-13. Sensing Input Connections



D1543-15

Figure 4-14. Output Connections

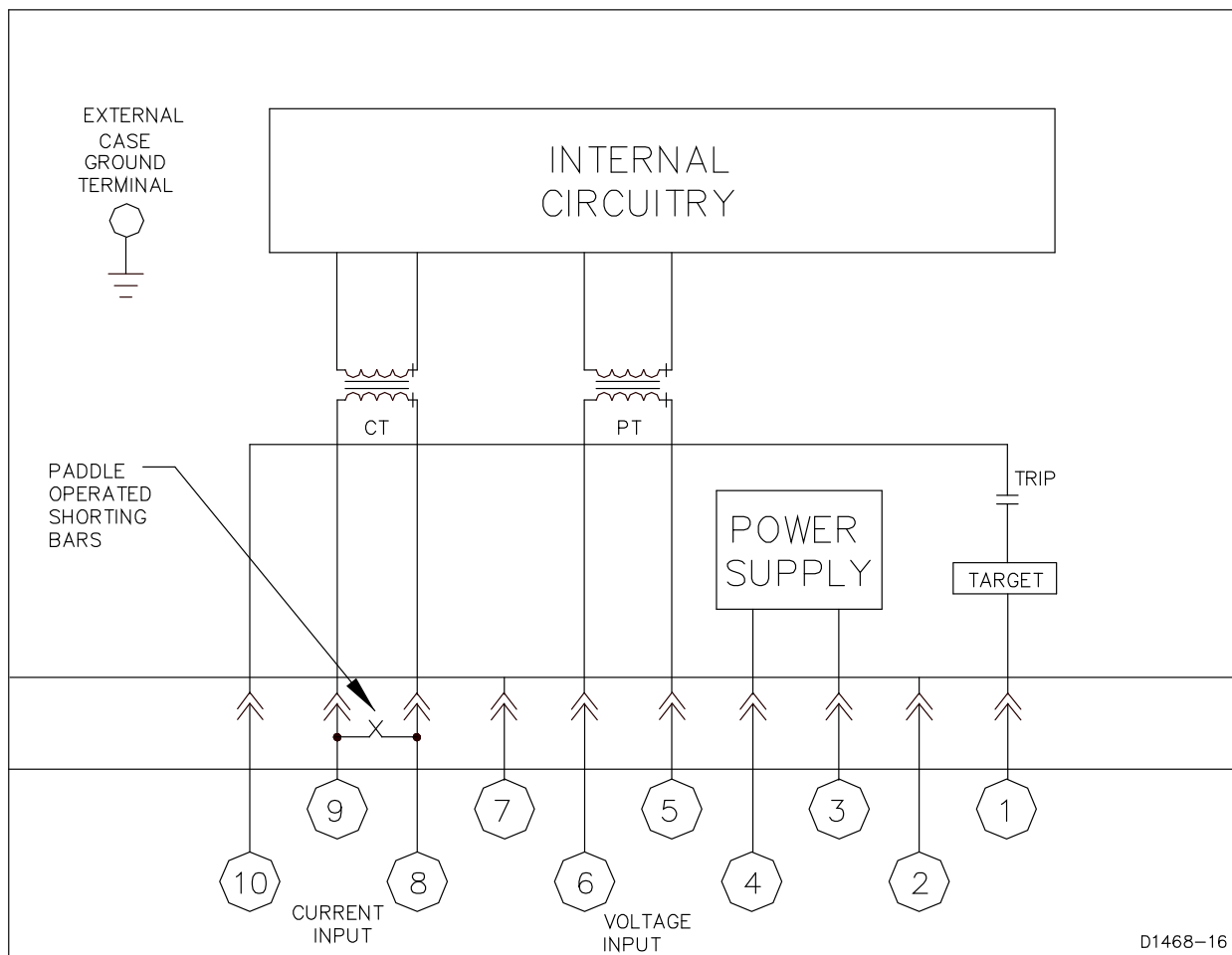

Figure 4-15. Interconnection with Current Operated Targets

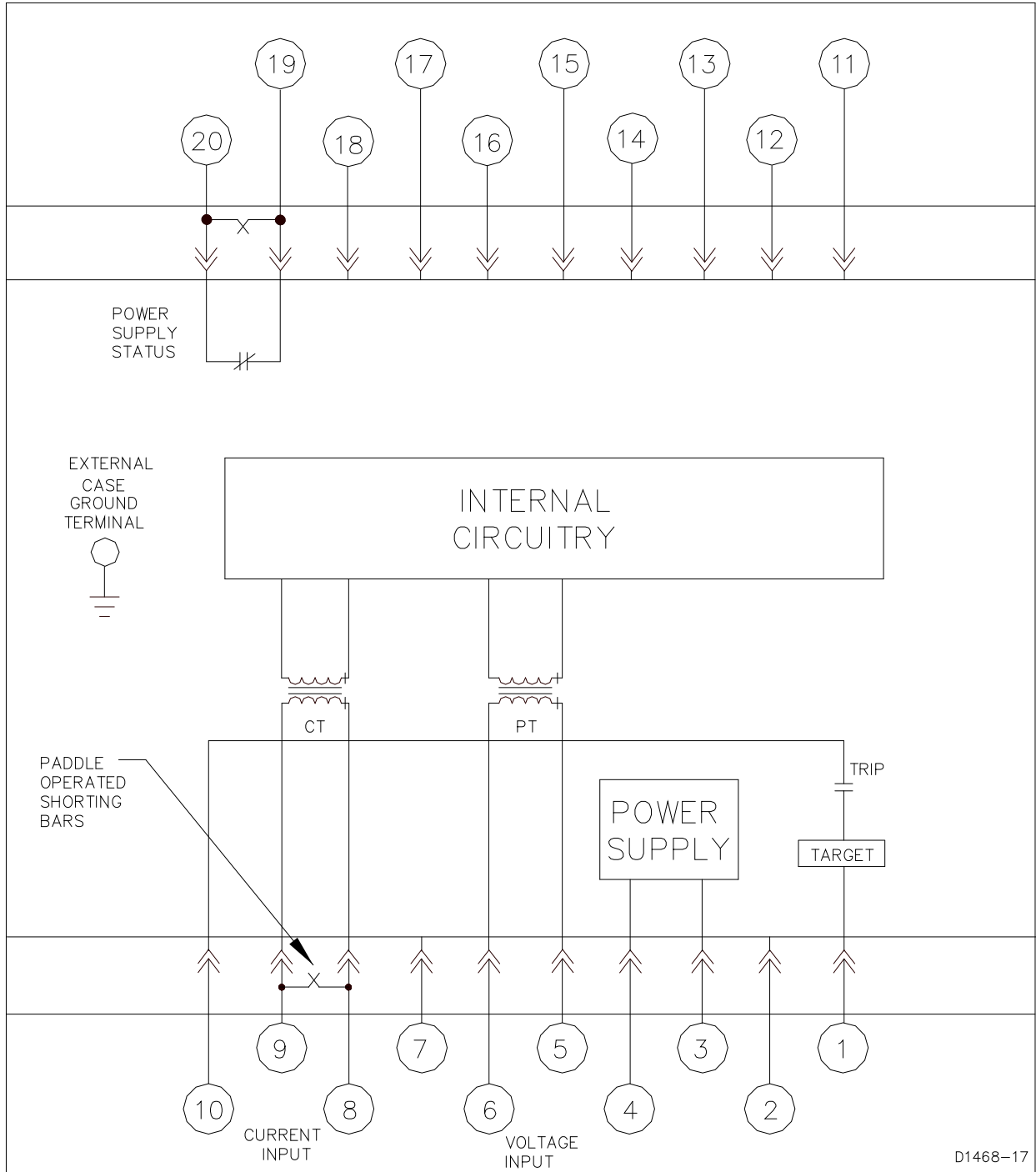

Figure 4-16. Interconnection with Current Operated Targets and Power Supply Status Output

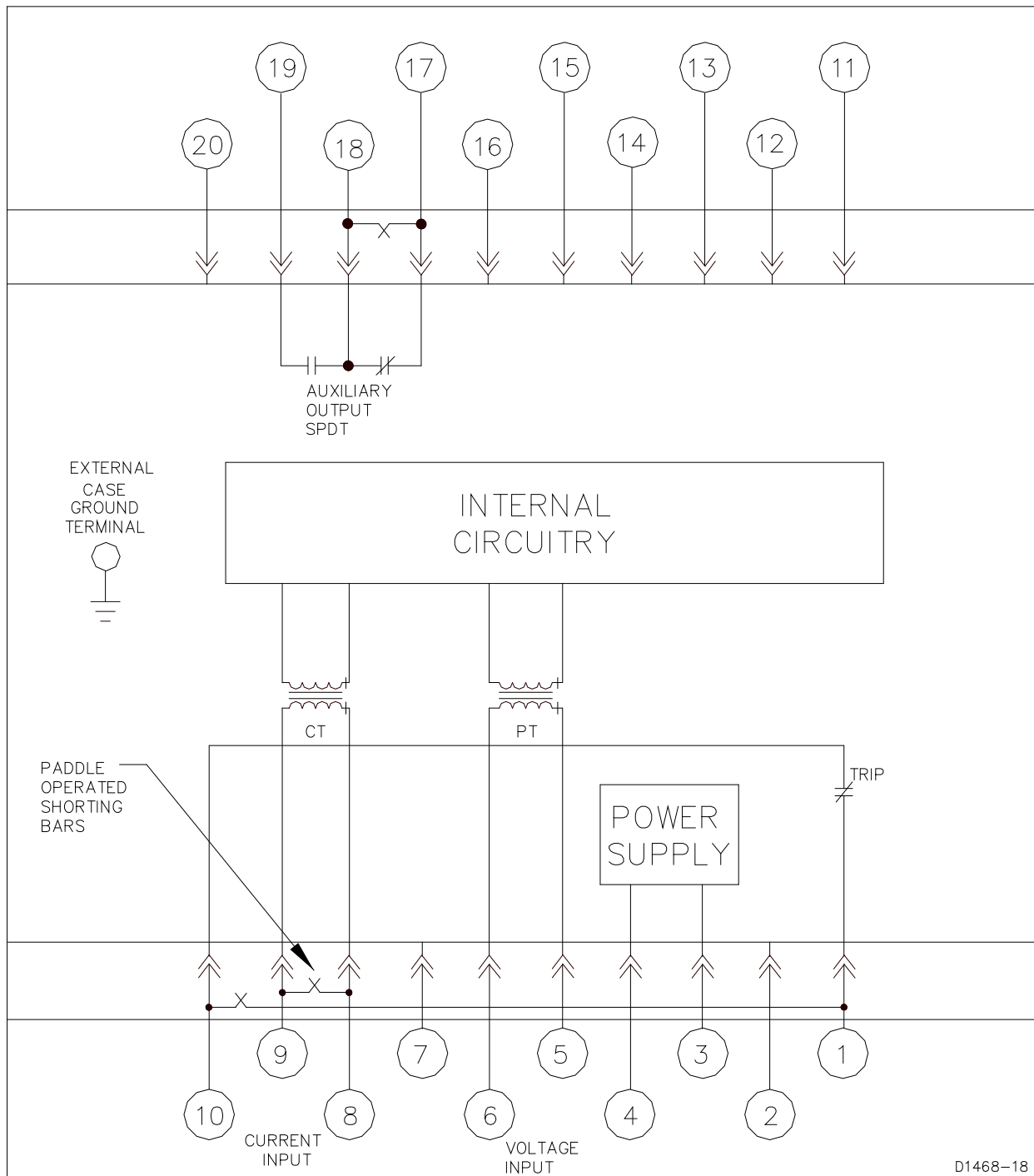

Figure 4-17. Interconnection with Internally Operated Target and Auxiliary Output Contacts (SPDT)

Maintenance

BE1-40Q relays require no preventative maintenance other than a periodic operational check. If the relay fails to function properly, contact Technical Sales Support at Basler Electric to coordinate repairs.

Storage

This device contains long-life aluminum electrolytic capacitors. For devices that are not in service (spares in storage), the life of these capacitors can be maximized by energizing the device for 30 minutes once per year.

5 • Setting and Testing

Setting

Setting the pickup value of BE1-40Q relays is facilitated by using the capability curves supplied by the generator manufacturer as shown previously in the examples in Section 1. The figure for relay operating characteristics is repeated here as Figure 5-1. Note that the line representing the relay characteristic is positioned on the curve 8° from horizontal and just above the point where the steady state stability limit arc intersects the capability curve. (The 8° slope applies to all BE1-40Q relays.)

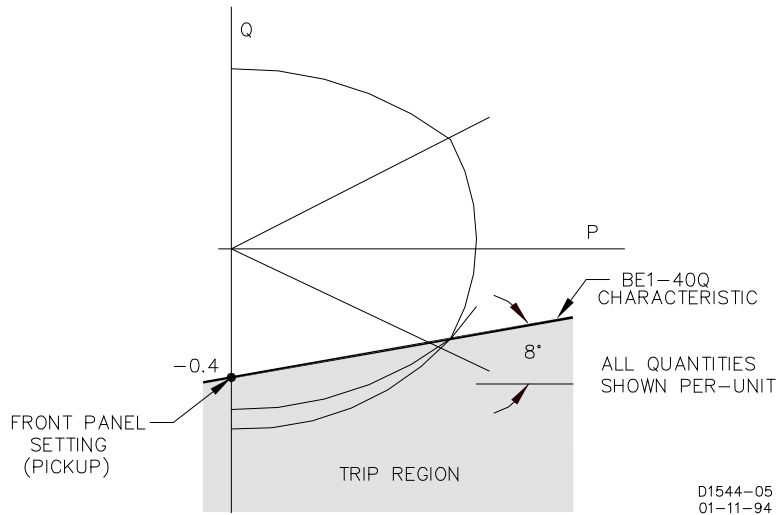

Figure 5-1. Example of BE1-40Q Relay Operating Characteristics

The pickup setting is determined by the point where the BE1-40Q characteristic intersects the Q axis in per unit (pu) quantities. Therefore, for the example shown in Figure 5-1, the pickup is -0.4 pu. The actual per unit pickup setting for your relay is determined by your specific application.

Per Unit Conversion Example

The per unit quantity is converted to a TAP switch setting by the procedure described in the following example.

Given:

Rated power	= 100 MVA
Rated voltage	= 12.8 kV
CT ratio	= 5000/5
PT ratio	= 12800/120

Step 1. Determine the desired primary vars.

Three-phase primary vars	= $0.4 \times$ rated power
	= 0.4×100 MVA
	= 40 Mvar
Single-phase primary vars	= 13.33 Mvar

Step 2. Determine the desired primary current.

$$\begin{aligned} \text{Primary current} &= (\text{single-phase primary var}) \left(\frac{\sqrt{3}}{V_{LL}} \right) \\ &= (13.33 \text{ Mvar}) \left(\frac{\sqrt{3}}{12800} \right) \\ &= 1804 \text{ A} \end{aligned}$$

Step 3. Specify a BE1-40Q relay having a nominal sensing range of 120 V_{LL} (for a PT ratio of 12800/120).

Step 4. Determine the desired secondary current.

$$\begin{aligned} \text{Secondary current} &= \frac{\text{Primary Current}}{\text{CT Ratio}} \\ &= \frac{1804}{5000/5} \\ &= 1.8 \text{ A} \end{aligned}$$

Step 5. Determine the pickup.

$$\begin{aligned} \text{Pickup} &= \frac{V_{relay}}{\sqrt{3}} \times I_{relay} \\ &= \frac{120}{\sqrt{3}} \times 1.8 \\ &= 125 \\ &= \text{Low Range, TAP position E (Table 1-1)} \end{aligned}$$

Operational Test

Introduction

The following procedures verify proper relay operation and calibration.

Results obtained from these procedures may not fall within specified tolerances. When evaluating results, consider three prominent factors:

- Test equipment accuracy
- Testing method
- External test set components tolerance level

Pickup Verification

Step 1. Connect the test circuit as shown in Figure 5-2. Apply appropriate operating power, depending on the power supply option (refer to the *Style Chart* in Section 1), to terminals 3 and 4. The POWER LED should illuminate.

Step 2. For relay styles with target indicators, actuate the target reset switch to insure that the target is reset.

- Step 3. Make the following front panel adjustments on the BE1-40Q relay:
- RANGE switch - LOW position
 - TAP switch - Position A (minimum)
 - TIME DELAY switches - 10 (1.0 second)
- Step 4. If equipped with a power supply status output relay (option 2-S), verify that the contact is open when external power is applied. Remove input power and verify that the status contacts close. Re-apply external power.

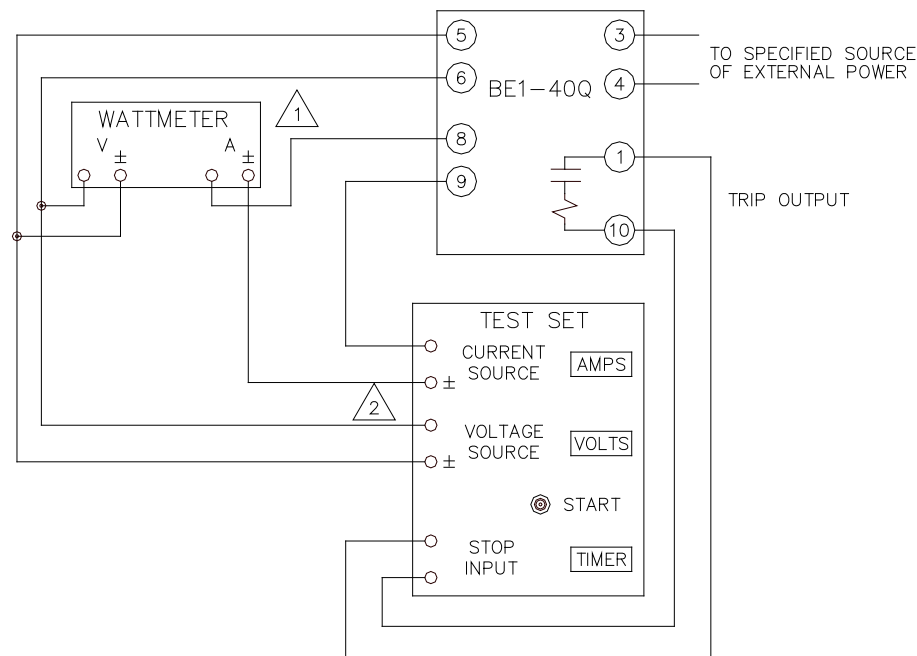

△ 1
$$\text{VARs} = \text{WATTMETER READING} / (\sqrt{3} \times \cos 60^\circ)$$

$$= \text{WATTMETER READING} / (0.8660)$$

△ 2 AMP SOURCE ANGLE FOR PHASE CALIBRATION = 68° LAGGING;
FOR PICKUP CALIBRATION = 60° LAGGING.

D610-001

Figure 5-2. Test Circuit Connections

- Step 5. Adjust the voltage source to the nominal value of the sensing input as designated by the second digit of the style number. (Refer to Table 5-1).

Table 5-1. Nominal Sensing Input Voltage

Second Digit of Style Number	Nominal Ac Voltage
2 or 3	120
5 or 6	208
8 or 9	240

- Step 6. Adjust the phase of the current source to produce an output that lags the voltage input by 60°.
- Step 7. Slowly increase the magnitude of the current source until the PICKUP LED illuminates. On units with target indicators, the indicator should illuminate.

Note

<p>The equation in Step 8 applies only to Step 8 of the Pickup Verification Test Procedure. For the pickup response of the BE1-40Q relay, see Section 3, <i>Functional Description</i>.</p>

Step 8. Note the indicated voltage and current, and calculate the actual pickup value as defined by:

$$\frac{V_{relay}}{\sqrt{3}} \times I_{relay}$$

Compare the result with Table 1-1 in Section 1. Reset the target indicator, if present.

Step 9. Repeat Steps 7 and 8 for each TAP setting, verifying both the HI and LOW range setpoints. The pickup tolerance should be $\pm 2\%$ of the front panel setting or 0.1 var, whichever is greater.

Timing Verification

Step 1. Connect the test circuit as shown in Figure 5-2.

Step 2. Connect a timer to record the time interval from application of the test current that will be applied in Step 6, to the change of state of the output relay. If a normally open contact has been selected, a trip will occur when the contact closes; normally closed contacts will open to trip.

Step 3. Make the following front panel adjustments on the BE1-40Q relay:

RANGE switch - LOW position

TAP switch - Position A (minimum)

TIME DELAY switches - 11 (1.1 second)

Step 4. Apply appropriate operating power, depending on the power supply option, to terminals 3 and 4. The POWER LED should illuminate.

Step 5. Adjust the voltage source to the nominal value of the sensing input as designated by the second digit of the style number.

Note

<p>The test current given in Table 5-2 is twice the pickup current.</p>

Step 6. Adjust the current source to produce a 60° lagging current that steps from zero magnitude to the test current value shown in Table 5-2.

Table 5-2. Test Current

Second Digit of Style Number	Nominal Ac Voltage	Pickup Current	Test Current
2	120	0.072 A	0.144 A
3	120	0.361 A	0.722 A
5	208	0.083 A	0.166 A
6	208	0.416 A	0.832 A
8	240	0.072 A	0.144 A
9	240	0.361 A	0.722 A

- Step 7. The actual time delay should be 1.05 to 1.15 seconds.
- Step 8. Adjust the TIME DELAY switches to a setting of 55 (5.5 seconds), and repeat Step 6. The time delay should be 5.22 to 5.77 seconds.
- Step 9. Adjust the TIME DELAY switches to a setting of 99 (9.9 seconds), and repeat Step 6. The time delay should be 9.40 to 10.39 seconds.

Relay Characteristics Verification

Preliminary

- Step 1. Connect the test circuit shown in Figure 5-2.
- Step 2. Adjust the BE1-40Q relay for the desired pickup value as specified by the generator application or the test setup capabilities.
- Step 3. Adjust the TIME DELAY switches to a minimum value (e.g., 0.1, 0.2, or 0.3 seconds).
- Step 4. Adjust the voltage source to the nominal value of the sensing input as designated by the second digit of the style number, at a leading phase angle of 150°.

Characteristic Data

- Step 1. Adjust the current source phase angle for each of the values indicated in Table 5-3. Record the magnitude of current required to receive each pickup indication. To measure pickup for each phase angle setting, slowly increase the current magnitude from zero or a value less than the pickup value until the PICKUP LED illuminates and an output contact operation occurs.

Note

With the test setup as specified, the current source phase angle setting simulates a leading power factor angle, i.e., $\Theta < 0$.

Table 5-3. Current Magnitudes Required for Pickup

Current Source Phase Angle Setting (Degrees)	Equivalent System Power Factor Angle (Θ) In Degrees	Current Magnitude Required for Pickup (Amps)
+20	-20	
+30	-30	
+40	-40	
+50	-50	
+60	-60	
+70	-70	
+80	-80	
+90	-90	
+100	-100	
+110	-110	
+120	-120	

Step 2. With the above recorded data, calculate P (watts) and Q (vars), as follows, for each recorded pickup value.

$$P = \frac{V_{LL}}{\sqrt{3}}(I_L)\cos\theta$$

$$Q = \frac{V_{LL}}{\sqrt{3}}(I_L)\sin\theta$$

Where:

V_{LL} = voltage measured in the test setup of Figure 5-2

I_L = current measured in the test setup of Figure 5-2

NOTE

If: $V = |V| \angle \alpha$ and $I = |I| \angle \beta$,

Then:

$$\text{Real power (P)} = |V| \times |I| \cos(\alpha - \beta),$$

$$\text{Reactive power (Q)} = |V| \times |I| \sin(\alpha - \beta), \text{ and}$$

$$\text{System power factor angle } (\Theta) = \alpha - \beta$$

Θ = the (-) angle setting of the current source

Step 3. The results from the above calculations can now be plotted on a graph of the complex power plane.

Graph Example

Given:

Relay style number is F3E-E1P-B1S1F. (Reference the *Style Chart*, Figure 1-4.)

Pickup is set to 125. (Reference Table 1-1.)

Test results are obtained as given in Step 1. For this example, we are using the data shown in columns [1] and [2] of Table 5-4.

Step 1. Calculate P and Q for a current phase angle of 20° ($\Theta = -20^\circ$).

$$\begin{aligned} P &= \frac{120}{\sqrt{3}}(3.806)\cos(-20^\circ) \\ &= 247.8 \text{ W} \end{aligned}$$

$$\begin{aligned} Q &= \frac{120}{\sqrt{3}}(3.806)\sin(-20^\circ) \\ &= -90.18 \text{ vars} \end{aligned}$$

Note that the above results for a phase angle of -20° have been entered in Table 5-4, columns [3] and [4], first row. Similarly, the values of P and Q can be solved for the other phase angles of column [1].

Step 2. Finally, the data from Table 5-4 is shown plotted on the complex power plane shown in Figure 5-3. A blank graph is provided as Figure 5-4.

Table 5-4. Data for the Hypothetical Graph of Figure 5-3

[1]		[2]	[3]	[4]
Current Source Phase Angle Degrees	System Phase Angle Θ	Current Magnitude for Pickup (Amps)	Real Power (Watts)	Reactive Power (Vars)
+20	-20	3.806	247.76	-90.18
+30	-30	2.902	174.12	-100.53
+40	-40	2.404	127.60	-107.07
+50	-50	2.107	93.82	-111.81
+60	-60	1.927	66.75	-115.62
+70	-70	1.827	43.28	-118.92
+80	-80	1.788	21.51	-121.98
+90	-90	1.804	0.00	-125.00
+100	-100	1.879	-22.60	-128.18
+110	-110	2.024	-47.95	-131.74
+120	-120	2.267	-78.54	-136.04

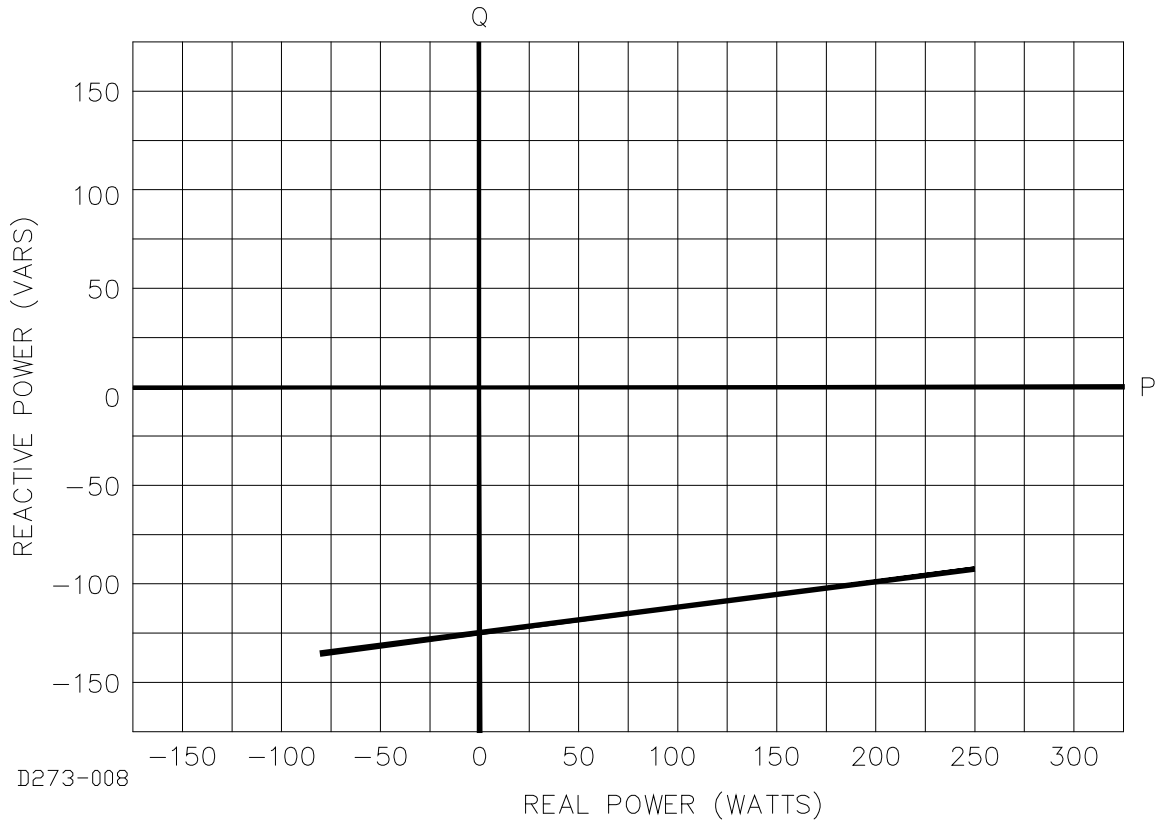
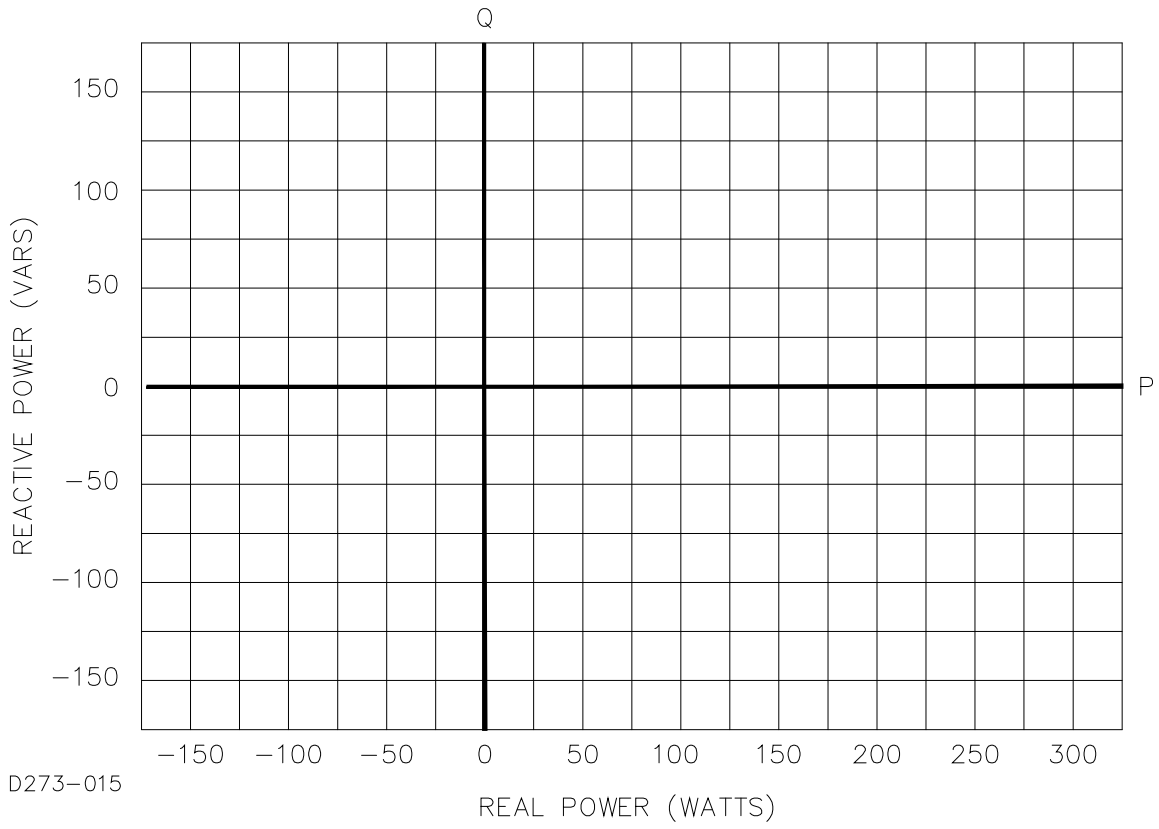

Figure 5-3. BE1-40Q Relay Characteristics Plotted on Complex Power Plane



D273-015

Figure 5-4. Blank Graph

 **Basler Electric®**
www.basler.com

12570 Route 143
Highland IL 62249-1074 USA
Tel: +1 618.654.2341
Fax: +1 618.654.2351
email: info@basler.com

No. 59 Heshun Road Loufeng District (N)
Suzhou Industrial Park
215122 Suzhou
P.R. CHINA
Tel: +86 512.8227.2888
Fax: +86 512.8227.2887
email: chinainfo@basler.com

111 North Bridge Road
15-06 Peninsula Plaza
Singapore 179098
Tel: +65 68.44.6445
Fax: +65 68.44.8902
email: singaporeinfo@basler.com