

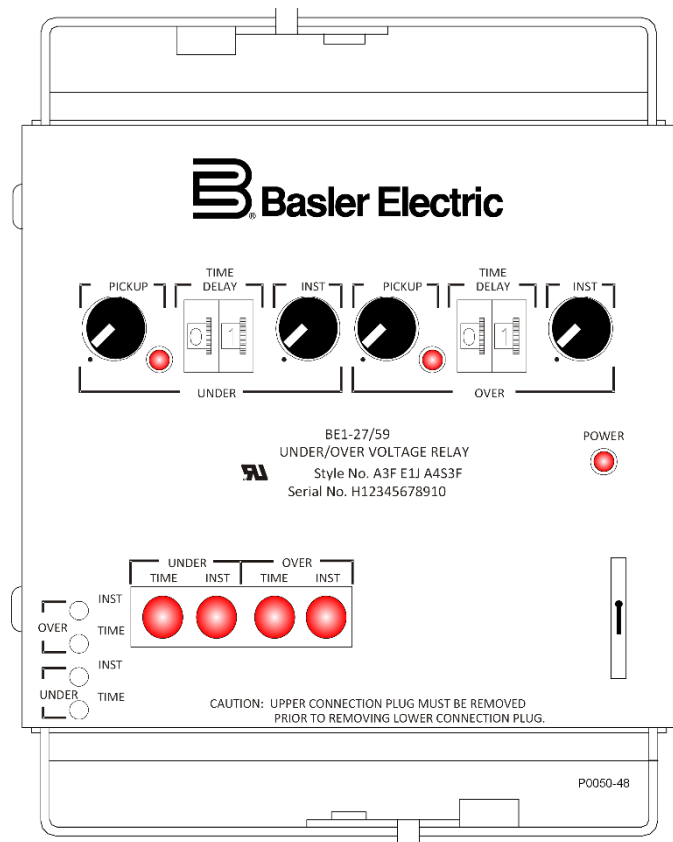



BE1-27, BE1-59, BE1-27/59 Voltage Relays

Instruction Manual



 **WARNING:** California's Proposition 65 requires special warnings for products that may contain chemicals known to the state of California to cause cancer, birth defects or other reproductive harm. Please note that by posting this Proposition 65 warning, we are notifying you that one or more of the Proposition 65 listed chemicals may be present in products we sell to you. For more information about the specific chemicals found in this product, please visit <https://www.basler.com/Prop65>.

Preface

This instruction manual provides information about the installation and operation of the BE1-27, BE1-59, and BE1-27/59 relays. To accomplish this, the following information is provided:

- General information and specifications
- Controls and indicators
- Functional description
- Installation
- Testing

Conventions Used in this Manual

Important safety and procedural information is emphasized and presented in this manual through warning, caution, and note boxes. Each type is illustrated and defined as follows.

Warning!

Warning boxes call attention to conditions or actions that may cause personal injury or death.

Caution

Caution boxes call attention to operating conditions that may lead to equipment or property damage.

Note

Note boxes emphasize important information pertaining to installation or operation.



12570 State Route 143
Highland IL 62249-1074 USA

www.basler.com
info@basler.com

Tel: +1 618.654.2341

Fax: +1 618.654.2351

© 2022 by Basler Electric

All rights reserved

First printing: January 1986

Warning!

READ THIS MANUAL. Read this manual before installing, operating, or maintaining this equipment. Note all warnings, cautions, and notes in this manual as well as on the product. Keep this manual with the product for reference. Only qualified personnel should install, operate, or service this system. Failure to follow warning and cautionary labels may result in personal injury or property damage. Exercise caution at all times.

Basler Electric does not assume any responsibility to compliance or noncompliance with national code, local code, or any other applicable code. This manual serves as reference material that must be well understood prior to installation, operation, or maintenance.

For terms of service relating to this product and software, see the *Commercial Terms of Products and Services* document available at www.basler.com/terms.

This publication contains confidential information of Basler Electric Company, an Illinois corporation. It is loaned for confidential use, subject to return on request, and with the mutual understanding that it will not be used in any manner detrimental to the interests of Basler Electric Company and used strictly for the purpose intended.

It is not the intention of this manual to cover all details and variations in equipment, nor does this manual provide data for every possible contingency regarding installation or operation. The availability and design of all features and options are subject to modification without notice. Over time, improvements and revisions may be made to this publication. Before performing any of the following procedures, contact Basler Electric for the latest revision of this manual.

The English-language version of this manual serves as the only approved manual version.

Revision History

A historical summary of the changes made to this instruction manual is provided below. Revisions are listed in reverse chronological order.

Instruction Manual Revision History

Manual Revision and Date	Change
P, May 2022	<ul style="list-style-type: none"> Added a note about EMI suppression in the <i>Installation</i> chapter
O	<ul style="list-style-type: none"> Revision letter O not used
N, Dec 2021	<ul style="list-style-type: none"> Adjusted style chart to reflect obsolescence of current-operated targets Relocated instruction manual revision history information to <i>Preface</i>
M2, Mar 2019	<ul style="list-style-type: none"> Adjusted wording of California Proposition 65 warning
M1, Oct 2018	<ul style="list-style-type: none"> Added California Proposition 65 warning
M, May 2017	<ul style="list-style-type: none"> Adjusted stated accuracy for inverse timing in <i>Specifications</i> section of <i>General Information</i> chapter Revised under and over inverse timing ranges listed under Timing section of <i>Testing</i> chapter Removed GOST-R certification Updated the style of the manual
L, Dec 2012	<ul style="list-style-type: none"> Standardized case and cover drawings in <i>Installation</i> chapter
K, Sep 1022	<ul style="list-style-type: none"> In style chart of <i>General Information</i> chapter, changed notes 3 and 4 and added note 5 Updated GOST-R statement in <i>General Information</i> chapter Updated storage statement in <i>Installation</i> chapter
J, Jul 2008	<ul style="list-style-type: none"> In style chart of <i>General Information</i> chapter, changed note 4 Removed "Range 2" from Figures 3-3, 3-5, 3-6, and 3-7
I	<ul style="list-style-type: none"> Revision letter I not used
H, Feb 2008	<ul style="list-style-type: none"> In style chart of <i>General Information</i> chapter, consolidated sensing input range options to cover all relay models
G, Sep 2007	<ul style="list-style-type: none"> Updated output contact ratings in <i>General Information</i> chapter Moved content of <i>Maintenance</i> chapter to the <i>Installation</i> chapter Updated front panel illustrations Relocated instruction manual revision history information to <i>Preface</i> Added instruction manual part number and revision to all page footers Updated cover drawing Updated power supply burden listed in <i>General Information</i> chapter Updated target indicator description in <i>Functional Description</i> chapter
F, Jun 2007	<ul style="list-style-type: none"> Updated the specifications of the <i>General Information</i> chapter
E, Jul 2004	<ul style="list-style-type: none"> Added missing square root symbol to equations of <i>System Voltages</i> paragraph of the <i>Functional Description</i> chapter
D, Jun 2003	<ul style="list-style-type: none"> Revised the resistive and inductive output contacts ratings listed in the <i>General Information</i> chapter Updated the definite time accuracy listed in the <i>General Information</i> chapter In Figures 3-2 through 3-4, deleted the Range 2 rows Added step 3 to the <i>Timing</i> section of the <i>Testing</i> chapter

Manual Revision and Date	Change
	<ul style="list-style-type: none"> • Adjusted the table referred to in Note 2 of Figure 5-2 • Adjusted the definite timing type specifications listed in Table 5-3
C, Nov 1999	<ul style="list-style-type: none"> • Added Figures 4-13, 4-14, and 4-15 • Added ground terminals to Figures 1-1 and 4-16 • Adjusted the characteristic curves shown in the <i>Functional Description</i> chapter for better accuracy • Added <i>Manual Change Information</i> chapter • Updated the style of the manual
B	<ul style="list-style-type: none"> • Change history not available
A	<ul style="list-style-type: none"> • Change history not available
—, Jan 1986	<ul style="list-style-type: none"> • Initial release

Contents

General Information	1-1
Controls and Indicators	2-1
Functional Description.....	3-1
Installation.....	4-1
Testing.....	5-1



1 • General Information

Purpose

The BE1-27 Undervoltage, BE1-59 Overvoltage and the BE1-27/59 Under/Overvoltage Relays are solid-state devices that provide reliable protection for generators, motors, and transformers against adverse system voltage conditions.

Application

Electric power systems are designed for constant voltage operation. Loads utilizing commercial electric power are designed to operate at a constant input voltage level with some tolerance. Radical voltage variations on a power system are indicative of a system malfunction. Protective relays that monitor system voltage and provide an output signal when the voltage goes outside predetermined limits, find a variety of applications. Some of these applications include motor and transformer protection, interface protection for cogeneration systems, and supervision of automatic transfer switching schemes.

Motor Protection

When selecting the type of protection for motor applications, the motor type, voltage rating, horsepower, thermal capability during start-up, and exposure to automatic transfer restarting following a voltage interruption need to be considered. During motor start-up, a low terminal voltage condition will inhibit the motor from reaching rated speed. The BE1-27 Undervoltage Relay will detect this low voltage condition and trip. Critical applications requiring continuous motor operation and applications where overloads during start-up may be maintained for a given time period, usually have a definite time or inverse time delay characteristic incorporated to avoid unnecessary tripping during low voltage dips. If the undervoltage condition persists for the established time delay, the relay output contacts are connected to the station alarm annunciator panel, allowing the station operator to take corrective action. The BE1-59 Overvoltage Relay is applied to insure the voltage does not exceed the limits established by the machine manufacturer for proper operation. Overvoltage conditions stress the insulation level of the equipment and may cause a dielectric breakdown resulting in a flash over to ground.

Automatic Transfer Switching

Distribution substations are sometimes designed with duplicate supply circuits and transformers to eliminate service interruptions due to faults located on the primary feeder. In order to restore service within a given acceptable time period, automatic transfer switching can be applied to initiate the throw over from primary power to the alternate power source. The BE1-27 Undervoltage Relay can initiate switching after a given time delay to void transfer switching during temporary low voltage conditions. To return the substation to normal service upon the restoration of primary voltage, the BE1-59 Overvoltage Relay supervises the transition to its normal operating condition.

Cogeneration

Utilities employ the use of a voltage check scheme to supervise reclosing at the substation when cogenerators are connected to a radial distribution feeder and the cogenerator is capable of supplying the entire load when the utility circuit breaker is open. During a faulted condition, the utility requires the cogenerator to be disconnected from the system before reclosing the utility breaker. If the cogenerator is connected to the system, the utility will reclose to an energized line.

This could result in reconnecting two systems out of synchronism with each other. A BE1-27 Undervoltage Relay monitoring the line voltage will inhibit reclosing of the utility circuit breaker if the cogenerator energizes the line.

At the interface between the utility and the cogenerator, overvoltage and undervoltage relays are installed as minimum protection to provide an operating voltage window for the cogenerator. During faulted conditions, when the cogenerator may become overloaded, the BE1-27 Undervoltage Relay will detect the decline in voltage and remove the cogenerator from the system. The BE1-59 Overvoltage Relay will

protect the system from overvoltage conditions that occur when power factor correction capacitors are located on the feeder.

Transformer Protection

Voltage relays can be applied to protect large transformers from damage because of overexcitation. The concern for transformer overvoltage may be minimized in many power system applications where proper voltage control of the generating unit is provided. However, where a tap changing regulating transformer is located between the generating source and the load, some form of voltage protection may be required to supplement the tap changing control and to prevent equipment damage due to over, as well as undervoltage resulting from a failure of the tap changing control. The BE1-27/59 Under/Overvoltage Relay is well suited for these applications.

Ground Fault Detection

In a three-phase, three-wire system, a single conductor may break or the insulation may deteriorate resulting in a high resistance ground fault that may not be detected by the overcurrent relays. This condition, however, may be sensed by an overvoltage relay connected to a grounded wye, broken delta set of potential transformers (PT's) as illustrated in Figure 1-1 with this connection, and a sensitive relay setting, an unbalanced voltage condition such as described above, can be quickly detected and isolated.

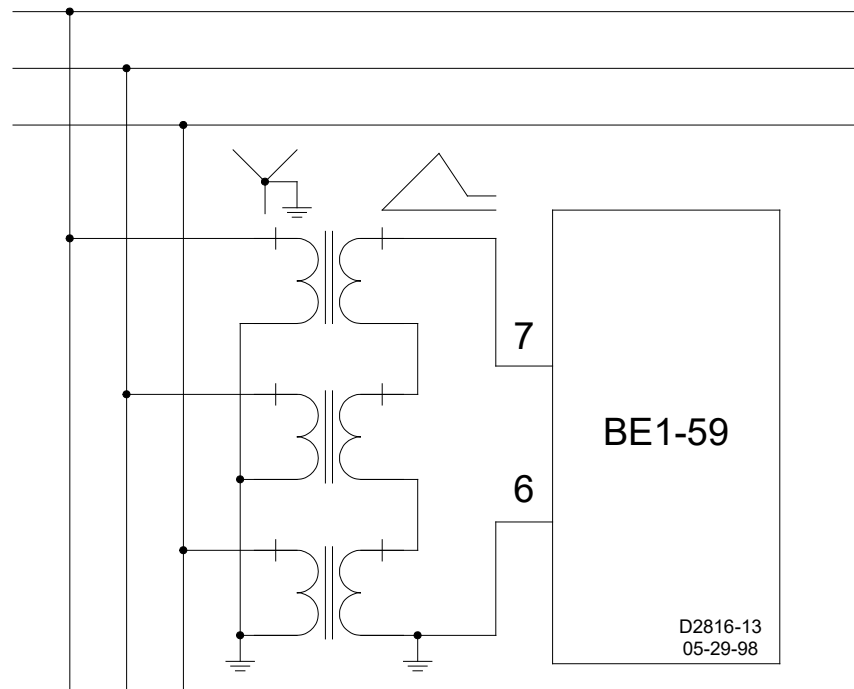

Figure 1-1. Ground Fault Detection

Model and Style Number

BE1-27, BE1-59, and BE1-27/59 electrical characteristics and operational features are defined by a combination of letters and numbers that make up the style number. Model number BE1-27/59 designates the relay as a Basler Electric Under/Overvoltage Protective Relay. The model number, together with the style number, describes the options included in a specific device and appears on the front panel, draw-out cradle, and inside the case assembly.

The style number identification chart for the BE1-27/59 relay is illustrated in Figure 1-2.

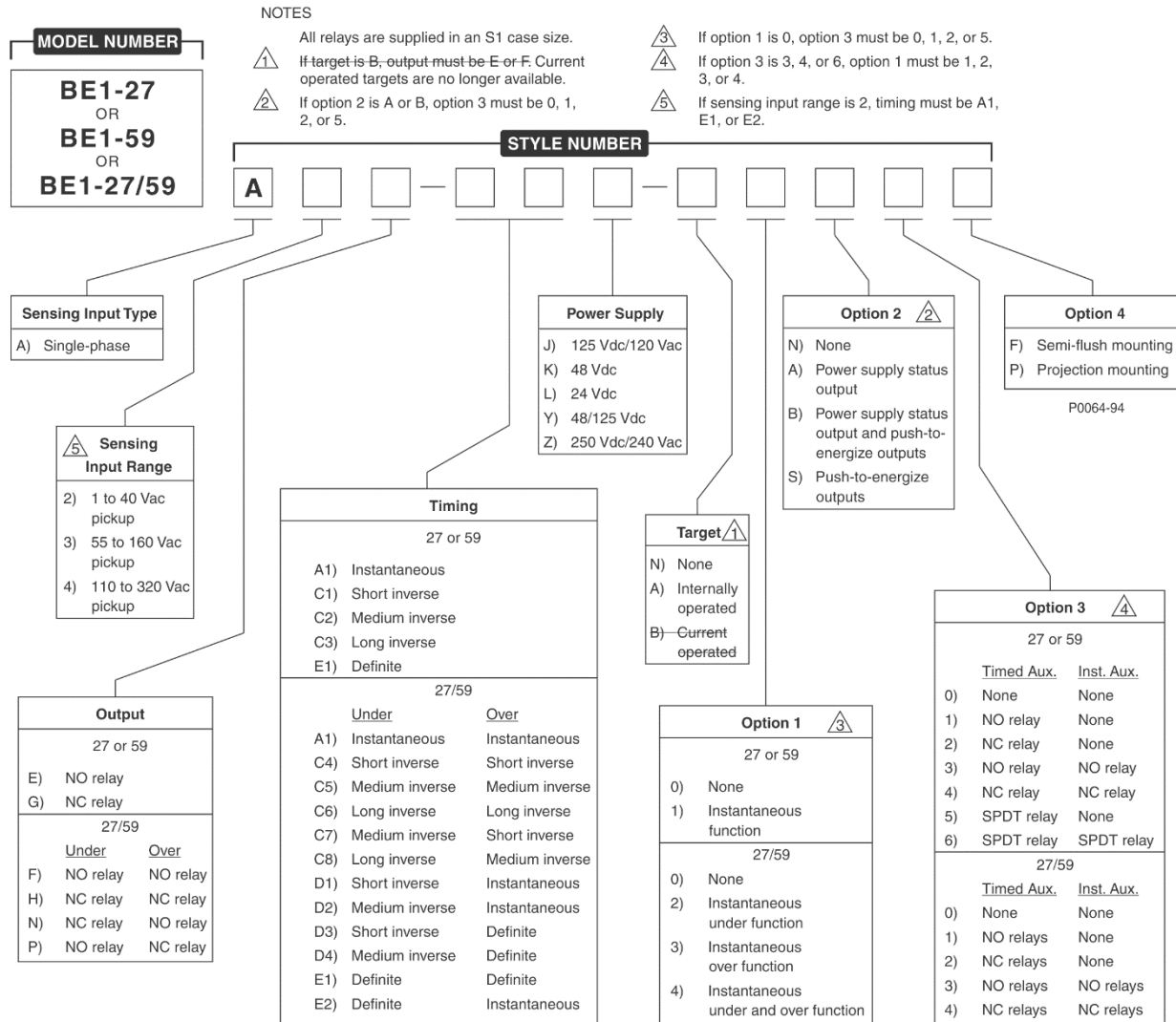

Figure 1-2. Style Number Identification Chart

Style Number Example

If a BE1-27/59 relay has a style number of A3F-E1J-A0S1F, the relay has the following features:

- A Single-phase voltage sensing input
- 3 Sensing input compatible with a pickup adjustment range of 55 to 160 Vac
- F 2 normally open output relays (one per function)
- E1 Definite timing for each function
- J Relay control power is 125 Vdc or 120 Vac, nominal
- A Two internally operated target indicators (one per function)
- 0 No instantaneous functions
- S Push-to-energize outputs
- 1 Two normally-open auxiliary output relays (one per function)
- F Semi-flush mounting case

Specifications

Electrical and physical specifications are listed in the following paragraphs.

Voltage Sensing Inputs

Nominally rated at 50/60 Hz, (120/240 V or 100/200 V) with a maximum continuous voltage rating of 360 V (120 V nominal) or 480 V (240 V nominal) at a burden less than 1 VA per phase. Frequency range is from 40 to 70 Hz.

Undervoltage and Overvoltage Pickup Range

Pickup Range	Continuously adjustable over the range of 1 to 40, 55 to 160, or 110 to 320 Vac as defined by the Style Chart. See Section 3, Functional Description, System Voltages, for explanation of pickup ranges.
Pickup Accuracy	$\pm 2\%$ or ± 0.5 volts of the pickup setting, whichever is greater.
Dropout	2% of pickup.

Timing Characteristics

Instantaneous	Less than 50 milliseconds for a voltage level that exceeds the pickup setting by 5% or 1 volt, whichever is greater
Definite	Adjustable from 0.1 to 9.9 seconds, in steps of 0.1 seconds. Accuracy is $\pm 2\%$ or ± 50 milliseconds, whichever is greater. (A setting of 0.0 provides instantaneous timing.)
Inverse	Inverse curve types are defined by the style chart and are represented by the curves shown in the <i>Functional Description</i> chapter. Inverse time is adjustable from 01 to 99 in increments of 01. Incrementing the time dial varies the inverse curve along the Y axis. A setting of 00 designates instantaneous timing. Accuracy is within $\pm 7.5\%$ or 200 milliseconds (whichever is greater) of the indicated time for any combination of the time dial setting and pickup setting and is repeatable within $\pm 2\%$ or 50 ms (whichever is greater) for any combination of time dial and tap setting. Curves were generated with pre-fault voltage at 10% greater than pickup for the 27 curves and 10% less than pickup for the 59 curves.

Output Contacts

Resistive Ratings

120 Vac	Make, break, and carry 7 Aac continuously
250 Vdc	Make and carry 30 Adc for 0.2 s, carry 7 Adc continuously, break 0.3 Adc
500 Vdc	Make and carry 15 Adc for 0.2 s, carry 7 Adc continuously, break 0.3 Adc

Inductive Ratings

120 Vac, 125 Vdc, 250 Vdc	Break 0.3 A (L/R = 0.04)
---------------------------	--------------------------

Power Supply

Power supply types and specifications are listed in Table 1-1.

Table 1-1. Power Supply Ratings

Type	Nominal Input Voltage	Input Voltage Range	Burden at Nominal
K (midrange)	48 Vdc	24 to 150 Vdc	3.8 W
J (midrange)	125 Vdc	24 to 150 Vdc	4.0 W
	120 Vac	90 to 132 Vac	17.1 VA
L (low range)	24 Vdc	12 to 32 Vdc *	3.9 W
Y (midrange)	48 Vdc	24 to 150 Vdc	3.8 W
	125 Vdc	24 to 150 Vdc	4.0 W
Z (high range)	250 Vdc	68 to 280 Vdc	4.1 W
	240 Vac	90 to 270 Vac	28.4 VA

* Type L power supply initially requires 14 Vdc to begin operating. Once operating, the input voltage may be reduced to 12 Vdc and operation will continue.

Target Indicators

Electronically latched, manually reset target indicators are optionally available to indicate closure of the trip output contacts. Either internally operated or current operated targets may be specified. Internally operated targets should be selected when normally closed (NC) output contacts are specified.

Current Operated Targets

Minimum Rating	200 mA flowing through the trip circuit
Continuous Rating	3 A
1 Second Rating	30 A
2 Minute Rating	7 A

Type Tests

Shock	Withstands 15 G in each of three mutually perpendicular planes without structural damage or performance degradation.
Vibration	Withstands 2 G in each of three mutually perpendicular planes, swept over the range of 10 to 500 Hz for a total of six sweeps, 15 minutes each sweep, without structural damage or degradation of performance.
Dielectric Strength	Tested in accordance with IEC 255-5 and IEEE C37.90: 2,000 Vac applied for 1 min
Impulse Test	Qualified to IEC 255-5
Radio Frequency Interference	Qualified to IEEE C37.90.2-1995, Standard for Withstand Capability of Relay Systems to Radiated Electromagnetic Interference from Transceivers.
Surge Withstand Capability	Qualified to IEEE C37.90.1-1989, Standard Surge Withstand Capability (SWC) Tests for Protective Relays and Relay Systems.

Temperature

Operating Range	-40 to 70°C (-40 to 158°F)
Storage Range	-65 to 100°C (-85 to 212°F)

Physical

Weight	14 lb. (6.35 kg)
Case Size	S1 (See the <i>Installation</i> chapter for panel cutting/drilling dimensions.)

Agency Recognition/Certification

UL Recognition	UL recognized per Standard 508, File E97033 NOTE: Output contacts are not UL recognized for voltages greater than 250 volts.
----------------	---

2 • Controls and Indicators

Introduction

Controls and indicators are located on the front panel. The controls and indicators are shown in Figure 2-1 and described in Table 2. Figure 3 illustrates a relay with the maximum number of controls and indicators. Your relay may not have all of the controls and indicators shown and described here.

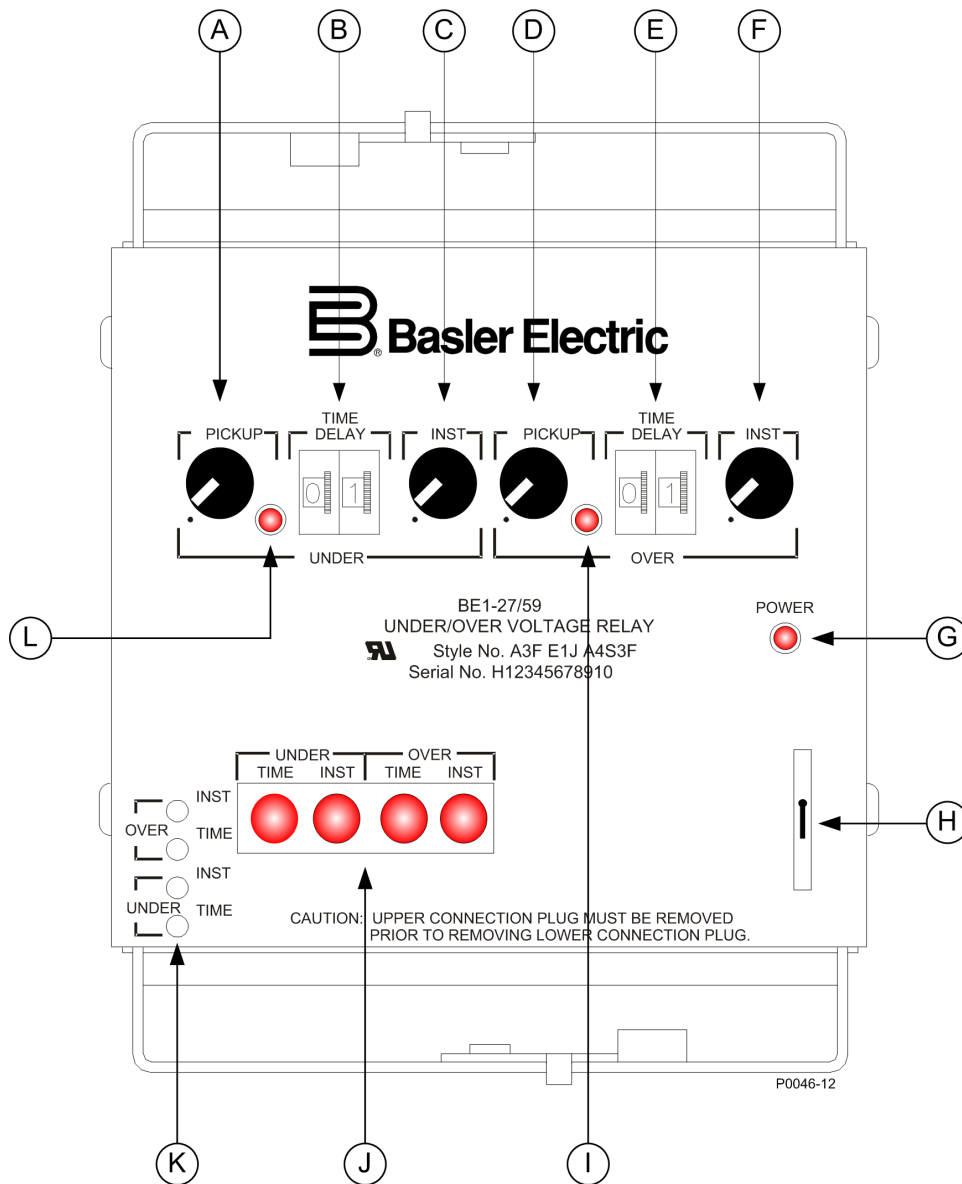

Figure 2-1. Controls and Indicators

Table 2-1. Control and Indicator Descriptions

Locator	Description
A	<i>Undervoltage Pickup Control.</i> Establishes setpoint for the timed undervoltage function. Continuously adjustable over the range defined by the style number.
B	<i>Undervoltage Time Delay Control.</i> Establishes the interval between undervoltage pickup and the time delayed output. Defined by the style number, this delay is either a user-adjustable definite time or inversely proportional to the magnitude of the undervoltage condition. A setting of 0.0 provides an instantaneous response. <u>Definite</u> - adjustable from 0.0 to 9.9 seconds in 0.1 second increments. <u>Inverse</u> - adjusts inverse timing characteristic curve relative to the time axis. (See the characteristic curves in Section 3.)
C	<i>Undervoltage Instantaneous Control.</i> Establishes setpoint for the instantaneous undervoltage function. Continuously adjustable over the range defined by the style number.
D	<i>Overvoltage Pickup Control.</i> Establishes setpoint for the timed overvoltage function. Continuously adjustable over the range defined by the style number.
E	<i>Overvoltage Time Delay Control.</i> Establishes the interval between overvoltage pickup and the time delayed output. Defined by the style number, this delay is either a user-adjustable definite time or inversely proportional to the magnitude of the overvoltage condition. A setting of 0.0 provides an instantaneous response. <u>Definite</u> - adjustable from 0.0 to 9.9 seconds in 0.1 second increments. <u>Inverse</u> - adjusts inverse timing characteristic curve relative to the time axis. (See the characteristic curves in Section 3.)
F	<i>Overvoltage Instantaneous Control.</i> Establishes setpoint for the instantaneous overvoltage function. Continuously adjustable over the range defined by the style number.
G	<i>Power Indicator.</i> This red LED lights when operating power is applied to the relay.
H	<i>Target Reset Switch.</i> This switch is operated to reset the target indicators.
I	<i>Overvoltage Pickup LED.</i> A red LED that illuminates when overvoltage exceeds the pickup setting.
J	<i>Target Indicators.</i> The electronically latched red target indicators illuminate when the corresponding output relay energizes. To ensure proper operation of current-operated targets, the current flowing through the trip circuit must be 200 mA or higher. Target indicators are reset by operating the target reset switch (locator H).
K	<i>Output Test Pushbuttons.</i> These pushbuttons allow manual actuation of the output relays. Output relay actuation is achieved by inserting a nonconductive rod through the front panel access holes.
L	<i>Undervoltage Pickup LED.</i> A red LED that illuminates when undervoltage exceeds the pickup setting.

3 • Functional Description

Introduction

BE1-27, BE1-59, and BE1-27/59 relay functions are illustrated in Figure 3-1 and described in the following paragraphs.

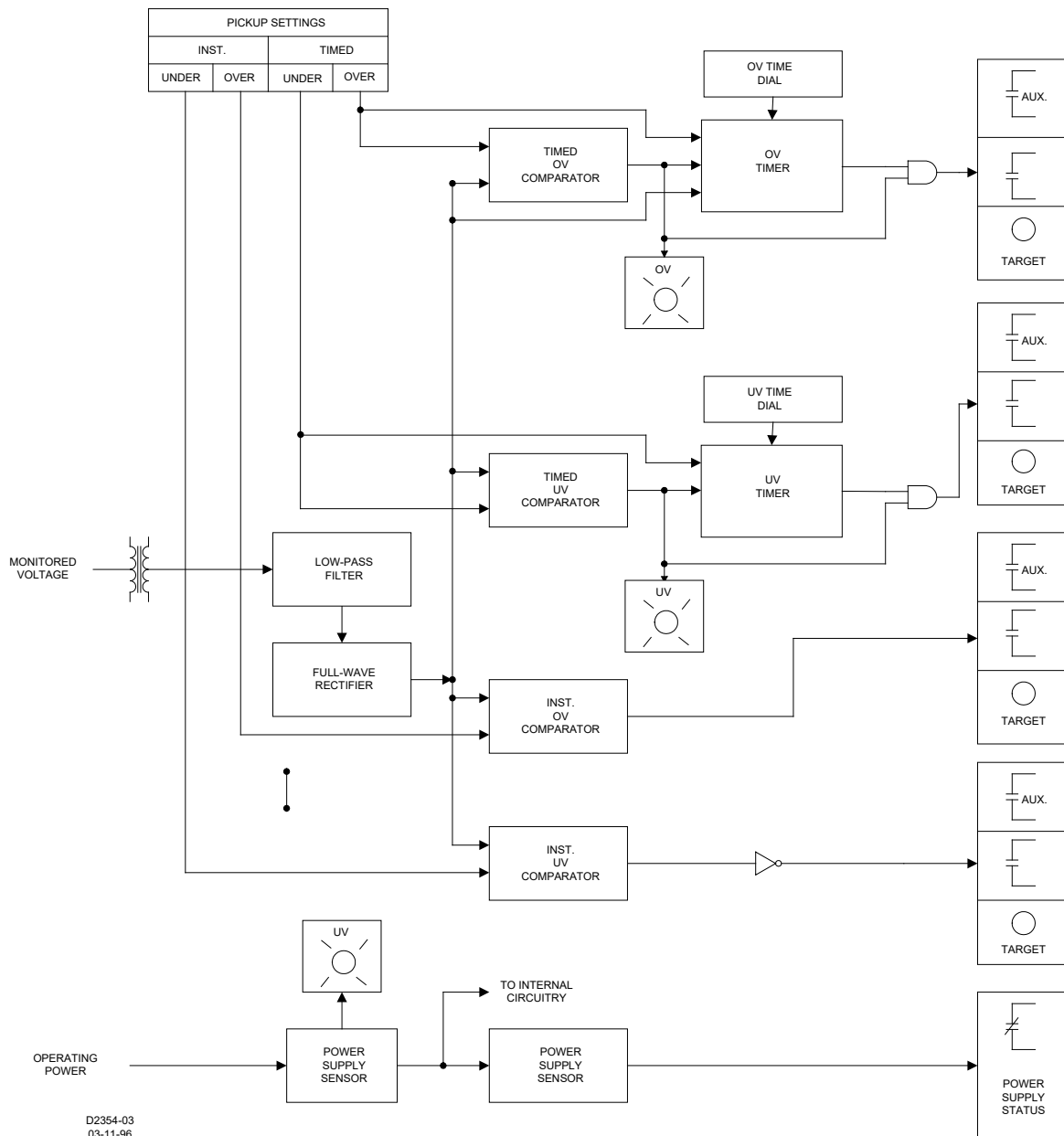

Figure 3-1. Function Block Diagram

System Voltages

The BE1-27, BE1-59, and BE1-27/59 relays are available with three sensing input ranges. The 55 to 160V range is intended for use with nominal system voltages of 120V or 69V ($120 \div \sqrt{3}$). The 110 to 320V range is intended for use with nominal system voltages of 240V, 208V ($120 \times \sqrt{3}$) or 277V ($480 \div \sqrt{3}$). The 1 to 40V range is intended for use with a wye/broken delta PT configuration with 120V or 69V ($120 \div \sqrt{3}$).

line-to-ground secondary voltages. The wye/broken delta PT configuration is a zero sequence filter capable of producing three times the line-to-ground voltage (3V_o).

Step-Down Transformer

The monitored system voltage is applied to the primary of an internal potential transformer and stepped down to internal circuit levels. The transformer provides a high degree of isolation.

Low-Pass Filter and Full Wave Rectifier

The output of the step-down transformer is low-pass filtered to prevent undesired response to high-frequency noise. Frequencies above 226 Hz are attenuated. The ac signal is then full-wave rectified to produce positive-going half-cycles that represent the magnitude of the monitored system voltage.

Pickup Settings

Controlled by front panel single-turn potentiometers, the pickup settings establish reference voltages representative of the system voltage that will cause the relay to respond. Pickup settings are individually adjustable for timed under/overvoltage functions and instantaneous under/overvoltage functions. On BE1-27/59, Under/Overvoltage Relays, the undervoltage function takes precedence over the overvoltage function.

Pickup Comparators

The output of the rectifier circuit is compared to each pickup setting. When the monitored system voltage is greater than any pickup setting, the affected comparator's output goes high. When the monitored system voltage is less than any pickup setting, the effected comparator's output goes low. The effects of these outputs are shown in Table 3-1.

Table 3-1. Pickup Comparator Operation

Comparator	Relevant Pickup Setting			
	Timed		Instantaneous	
	Undervoltage	Overvoltage	Undervoltage	Overvoltage
High	No effect	Lights OV pickup indicator; initiates timer	No effect	Energizes output relay
Low	Lights UV pickup indicator; initiates timer	No effect	Energizes output relay	No effect

Timer Circuit

Once initiated, the timer circuit measures the interval from pickup. If the adverse condition continues through the programmed delay, the timer circuit energizes the appropriate output relay. In relay styles with inverse timing, the extent to which the monitored system voltage exceeds the pickup setting influences the actual time delay such that a greater voltage difference from pickup produces a more rapid response. This response is illustrated in the characteristic curves as shown in Figures 3-2 through 3-7.

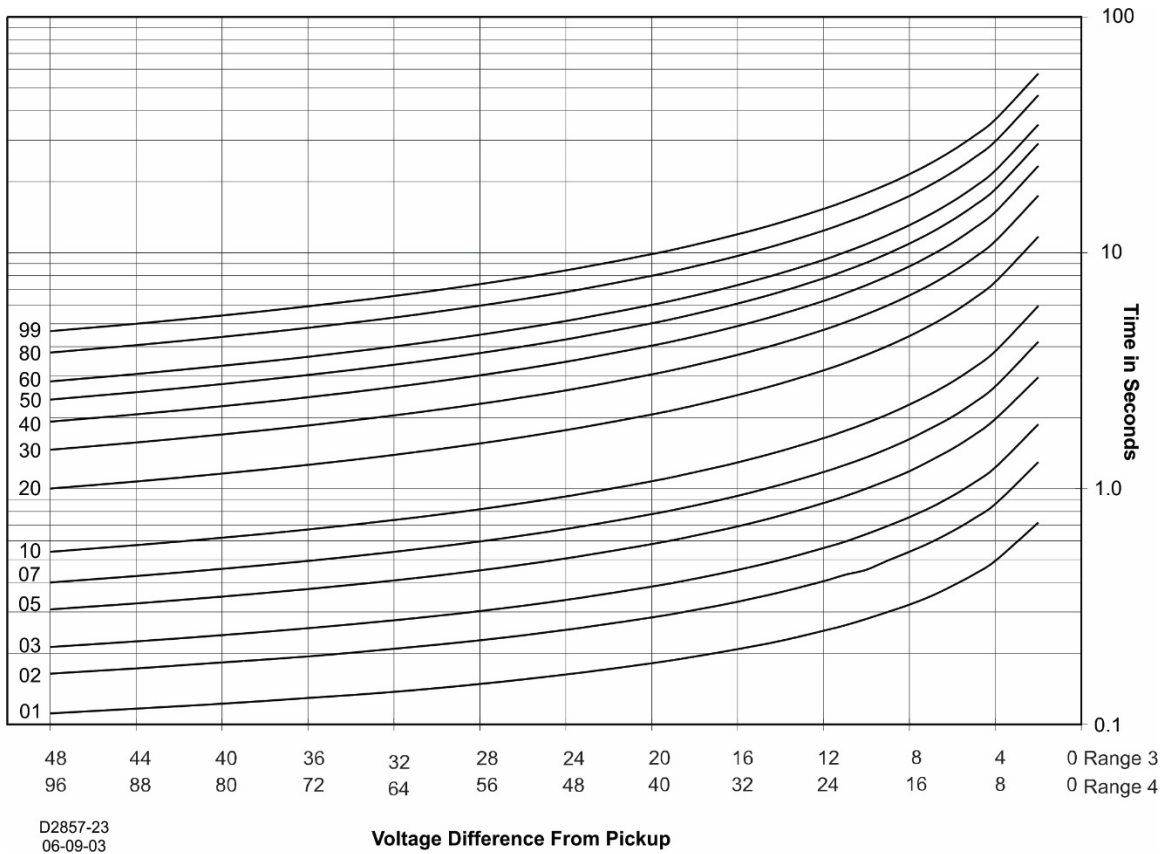

Figure 3-2. Undervoltage, Short Inverse Timing characteristic Curve

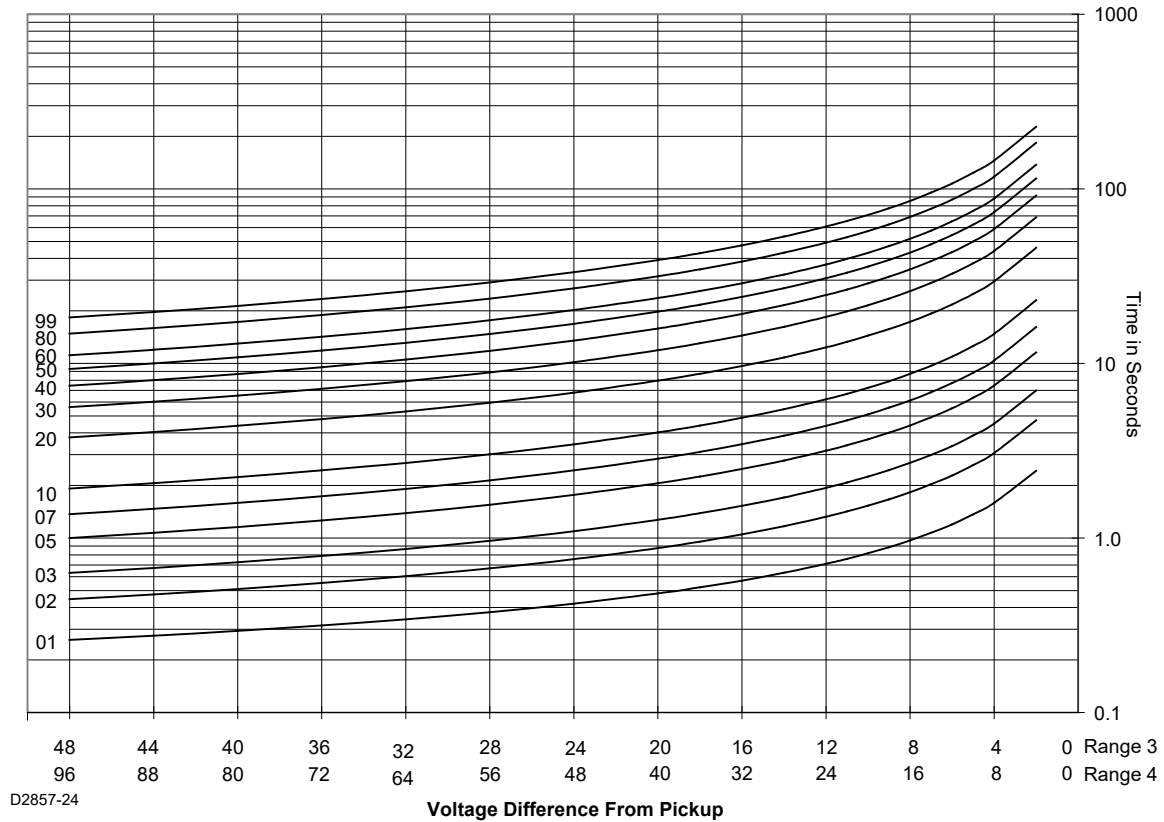

Figure 3-3. Undervoltage, Medium Inverse Timing Characteristic Curve

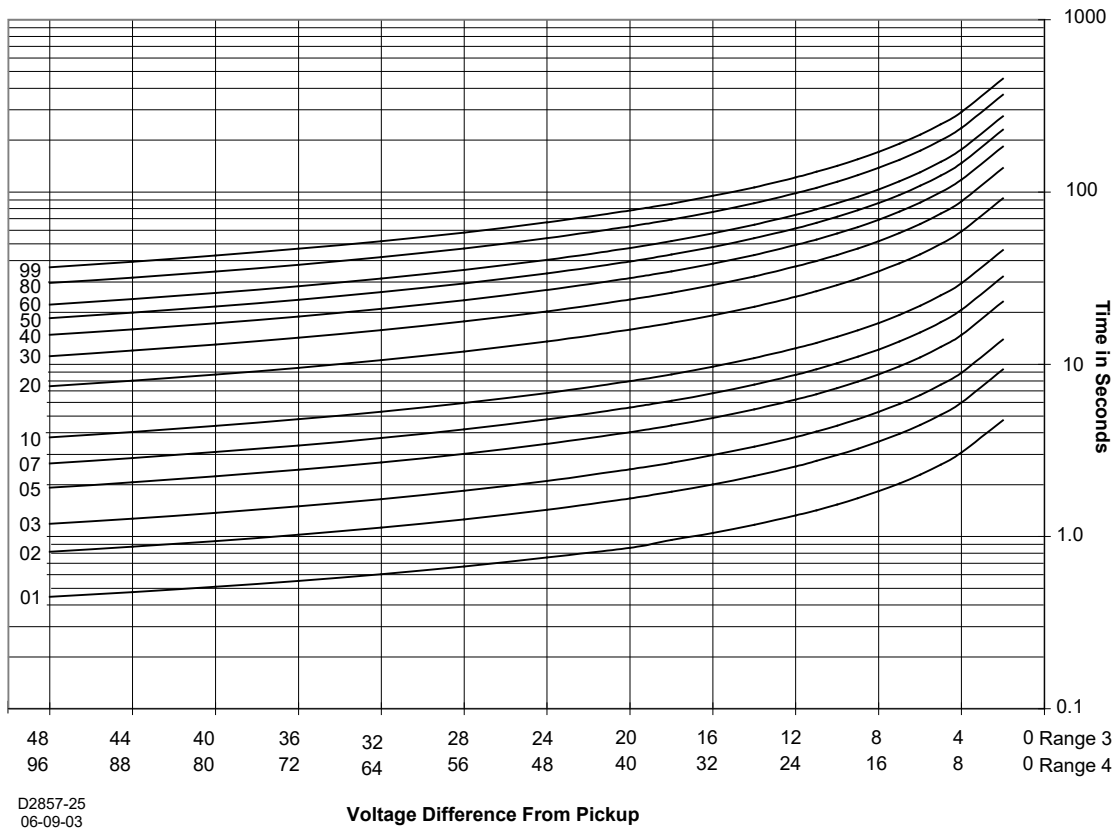

Figure 3-4. Undervoltage, Long Inverse Timing Characteristic Curve

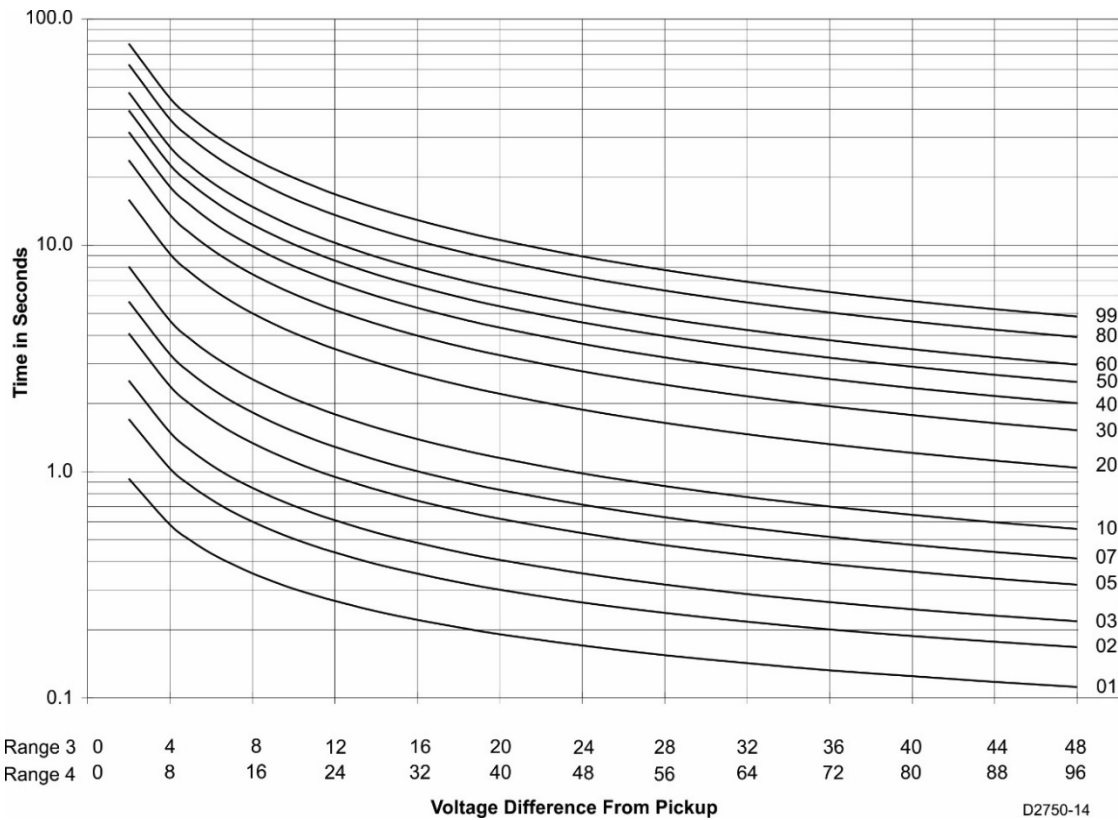

Figure 3-5. Overvoltage, Short Inverse Timing Characteristic Curve

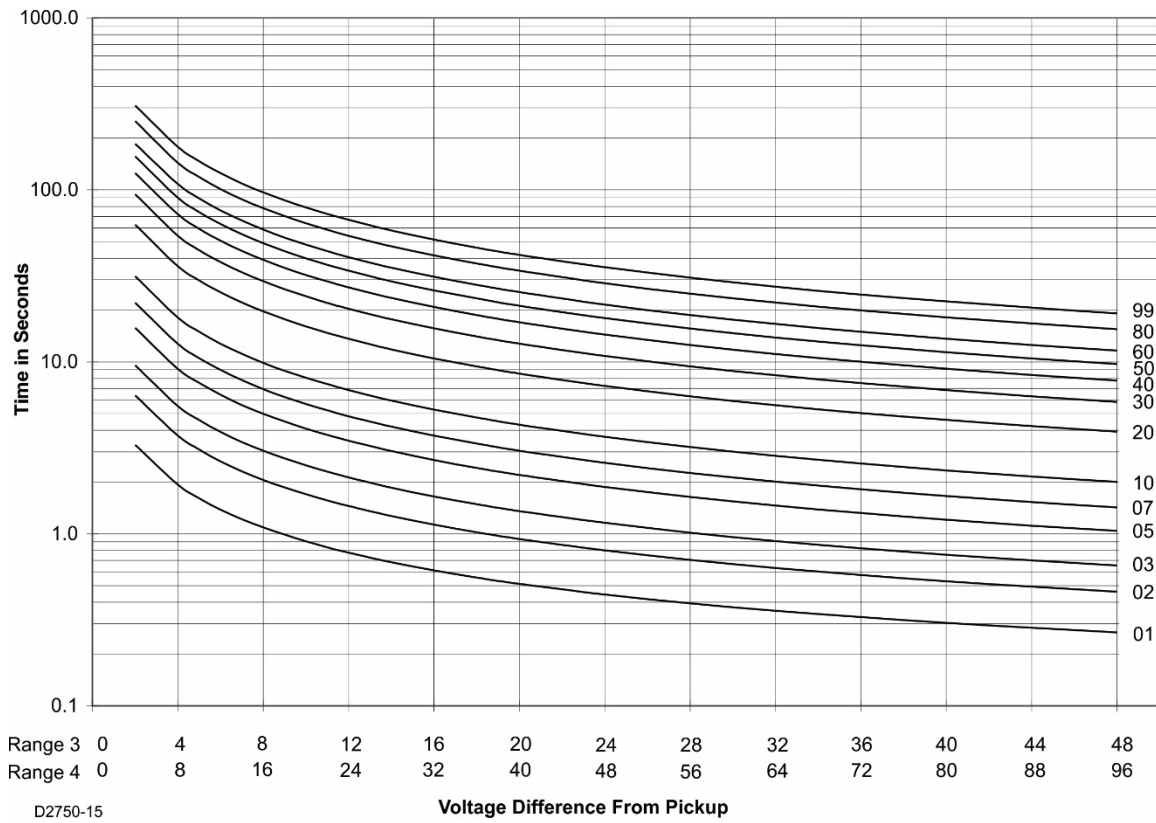

Figure 3-6. Overtoltage, Medium Inverse Timing Characteristic Curve

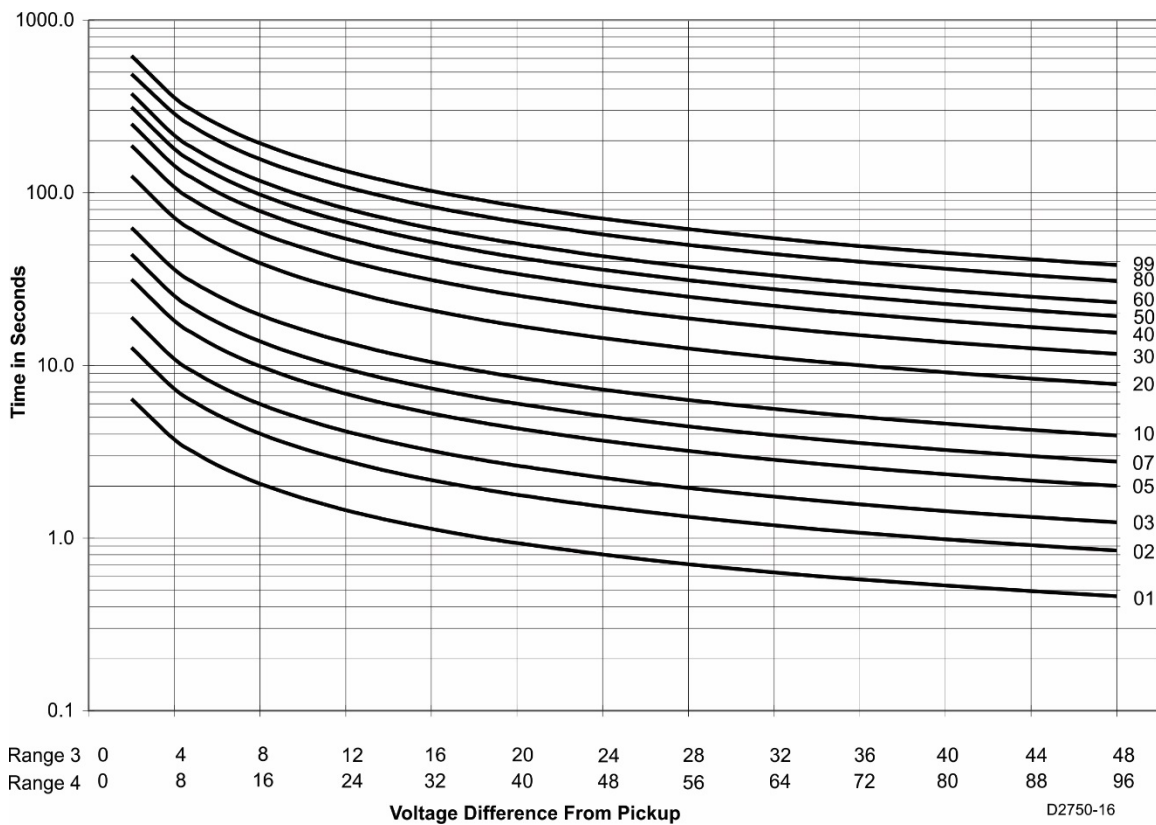

Figure 3-7. Overtoltage, Long Inverse Timing Characteristic Curve

Outputs

Defined by the style number, the output relays may be provided for each of the following functions: timed undervoltage, timed overvoltage, instantaneous undervoltage, and instantaneous overvoltage. Auxiliary output relays may be provided for each of these functions as well. Once energized, output relays will remain energized until the adverse condition stops.

Push-To-Energize Output Pushbuttons

Small pushbutton switches may be provided as an option to allow testing the primary output contacts and (if present) the auxiliary output contacts. To prevent accidental operation, the pushbuttons are recessed behind the front panel and are depressed by inserting a thin, non-conducting rod through an access hole in the front panel.

Power Supply Status Output

The power supply status relay has a set of normally closed contacts and energizes when operating power is applied to the relay. If relay operating power is lost or either side of the power supply output (+12 Vdc or -12 Vdc) fails, the power supply status relay de-energizes and closes the power supply status output contacts.

Power Supply

Operating power for the relay circuitry is supplied by a wide range, electrically isolated, low-burden power supply. Power supply operating power is not polarity sensitive. The front panel power LED and power supply status output indicate when the power supply is operating. Power supply specifications are listed in Table 1.

Target Indicators

Target indicators are optional components selected when a relay is ordered. The electronically latched and reset targets consist of red LED indicators located on the relay front panel. A latched target is reset by operating the target reset switch on the front panel. If relay operating power is lost, any illuminated (latched) targets are extinguished. When relay operating power is restored, the previously latched targets are restored to their latched state.

A relay can be equipped with either internally operated targets or current operated targets.

Internally Operated Targets

The relay trip outputs are directly applied to drive the appropriate target indicator. Each indicator is illuminated regardless of the current level in the trip circuit.

Current Operated Targets

A current operated target is triggered by closure of the corresponding output contact and the presence of at least 200 milliamperes of current flowing in the trip circuit.

Note
Prior to September 2007, BE1-27/59 target indicators consisted of magnetically latched, disc indicators. These mechanically latched target indicators have been replaced by the electronically latched LED targets in use today.

4 • Installation

Introduction

The relays are shipped in sturdy cartons to prevent damage during transit. Upon receipt of a relay, check the model and style number against the requisition and packing list to see that they agree. Inspect the relay for shipping damage. If there is evidence of damage, file a claim with the carrier, and notify your sales representative or Basler Electric.

If the relay will not be installed immediately, store it in its original shipping carton in a moisture- and dust-free environment. Before placing the relay in service, it is recommended that the test procedures of the *Testing* chapter be performed.

Relay Operating Guidelines and Precautions

Before installing or operating the relay, note the following guidelines and precautions.

- For proper current operated target operation, a minimum current of 200 milliamperes must flow through the output trip circuit.
- If a wiring insulation test is required, remove the connection plugs and withdraw the relay from its case.
- An undervoltage target indication may occur when the lower connection paddle is removed if:
 - The instantaneous time function is selected, or
 - A time delay (definite or inverse) below 0.3 seconds is selected.
 - No actual trip output occurs if the upper paddle is removed first.

Caution

When the connection plugs are removed, the relay is disconnected from the operating circuit and will not provide system protection. Always be sure that external operating (monitored) conditions are stable before removing a relay for inspection, test or service.

Notes

Be sure that the relay is hard-wired to earth ground with no smaller than 12 AWG copper wire attached to the ground terminal on the rear of the case. When the relay is configured in a system with other devices, it is recommended to use a separate lead to the ground bus from each device.

It is recommended in all applications where contact outputs drive relay coils that a reverse biased diode be implemented in parallel with the relay coil for EMI suppression.

Mounting

Because the relay is of solid-state design, it does not have to be mounted vertically. Any convenient mounting angle may be chosen.

A panel cutting/drilling diagram for a semi-flush, S1 case is illustrated in Figure 4-1. An outline of the case cover is shown around the cut-out. Relay outline dimensions and panel drilling diagrams are illustrated in Figures 4-2 through 4-12.

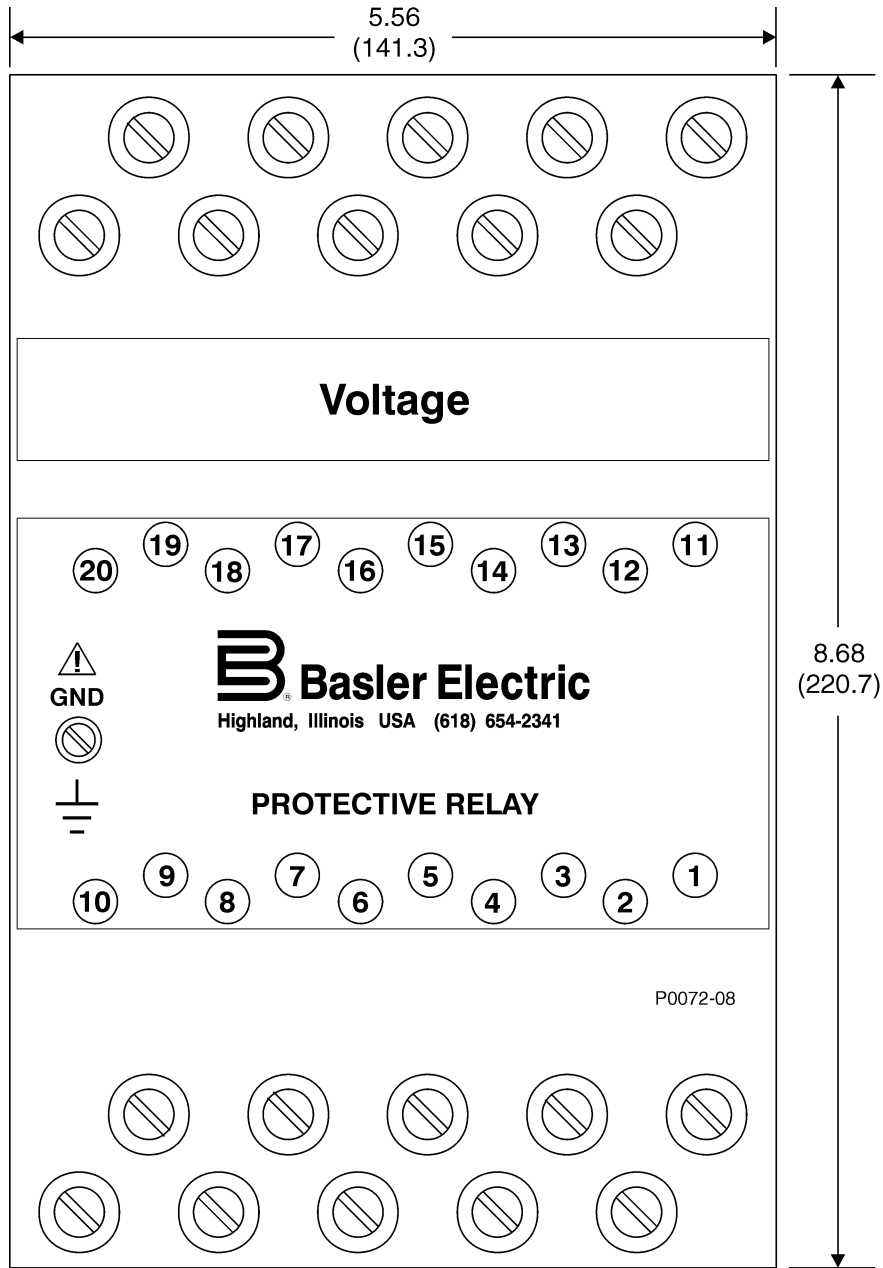

Figure 4-2. S1 Case Dimensions, Rear View, Double-Ended, Seme-Flush Mount

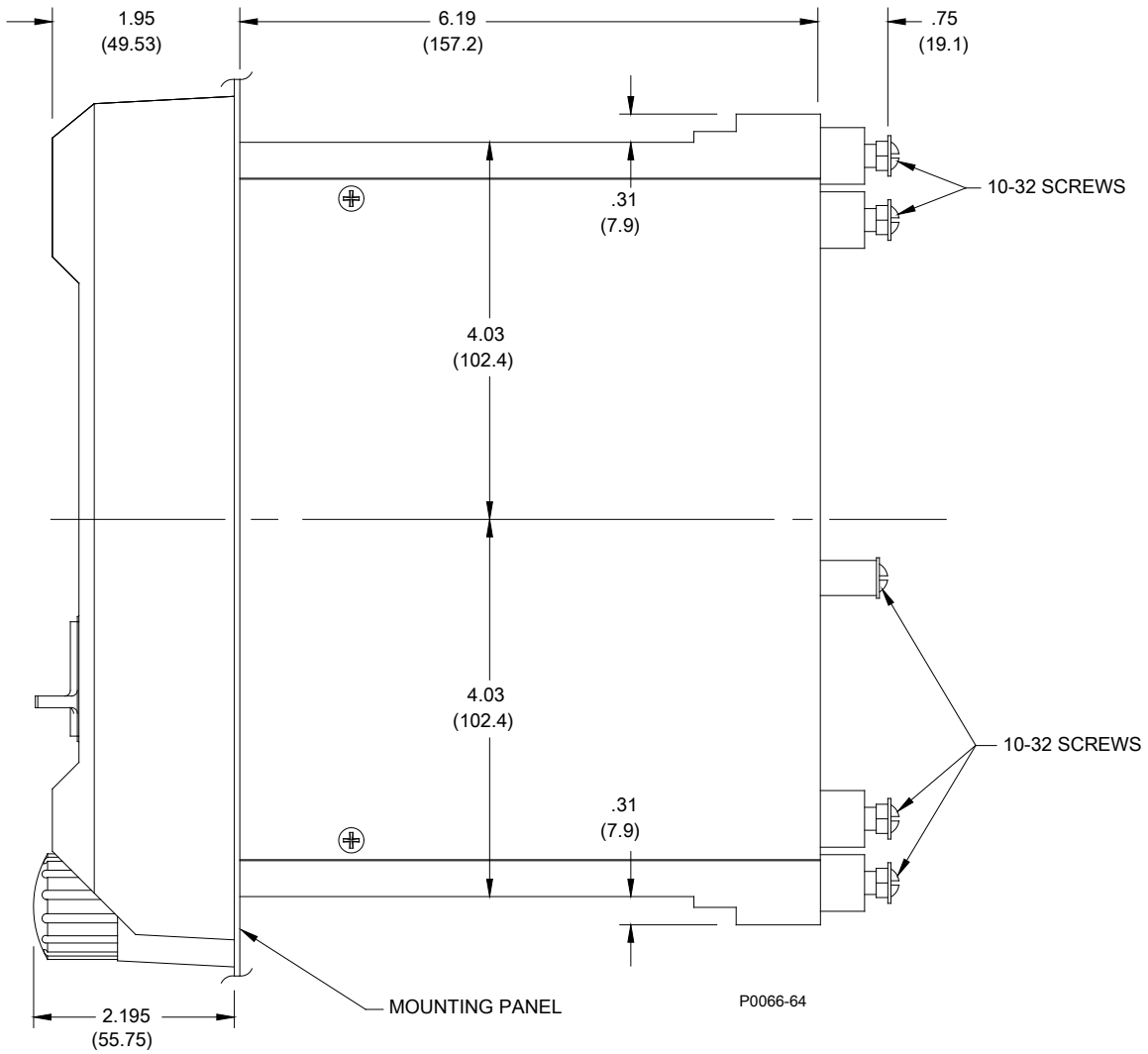

Figure 4-3. S1 Case Dimensions, Side View, Double-Ended, Semi-Flush Mount

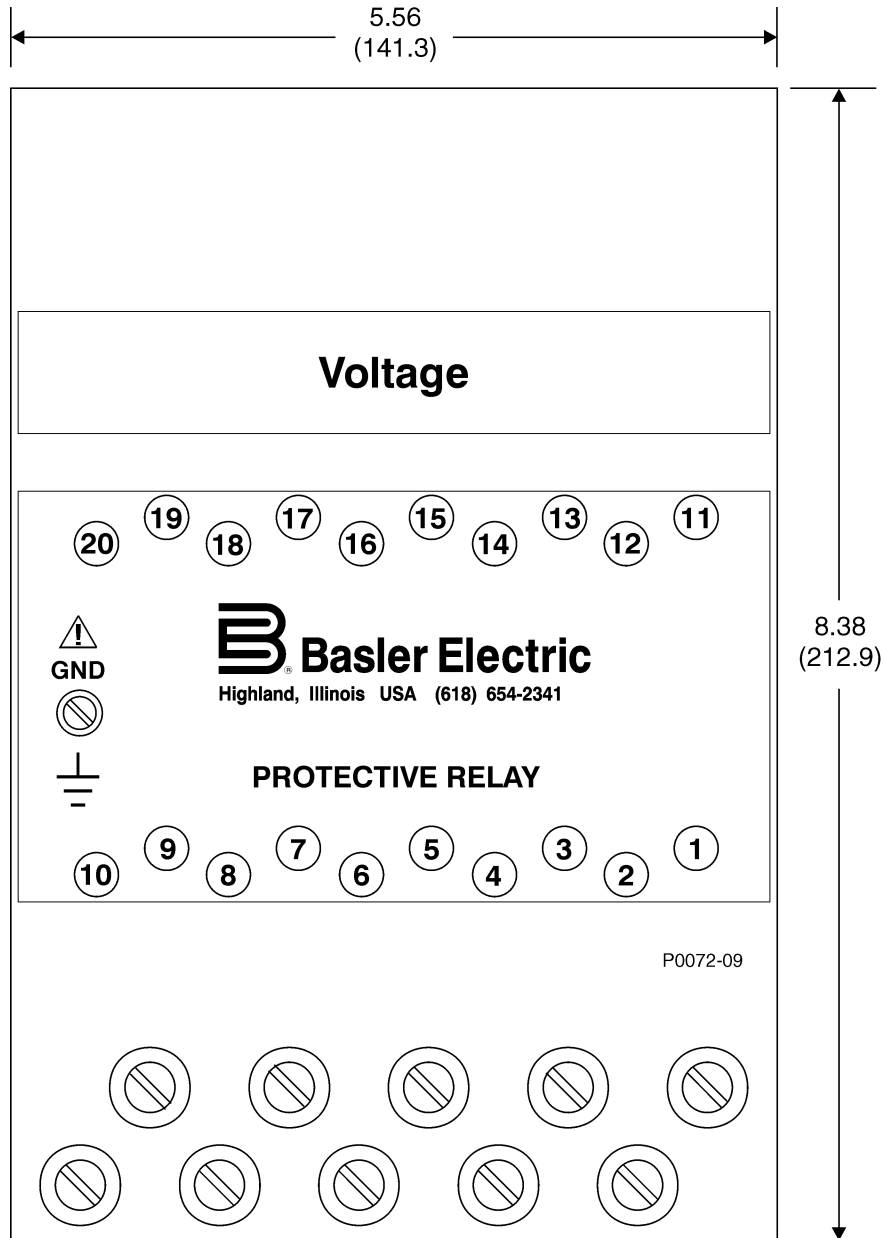

Figure 4-4. S1 Case Dimensions, Rear View, Single-Ended, Semi-Flush Mount

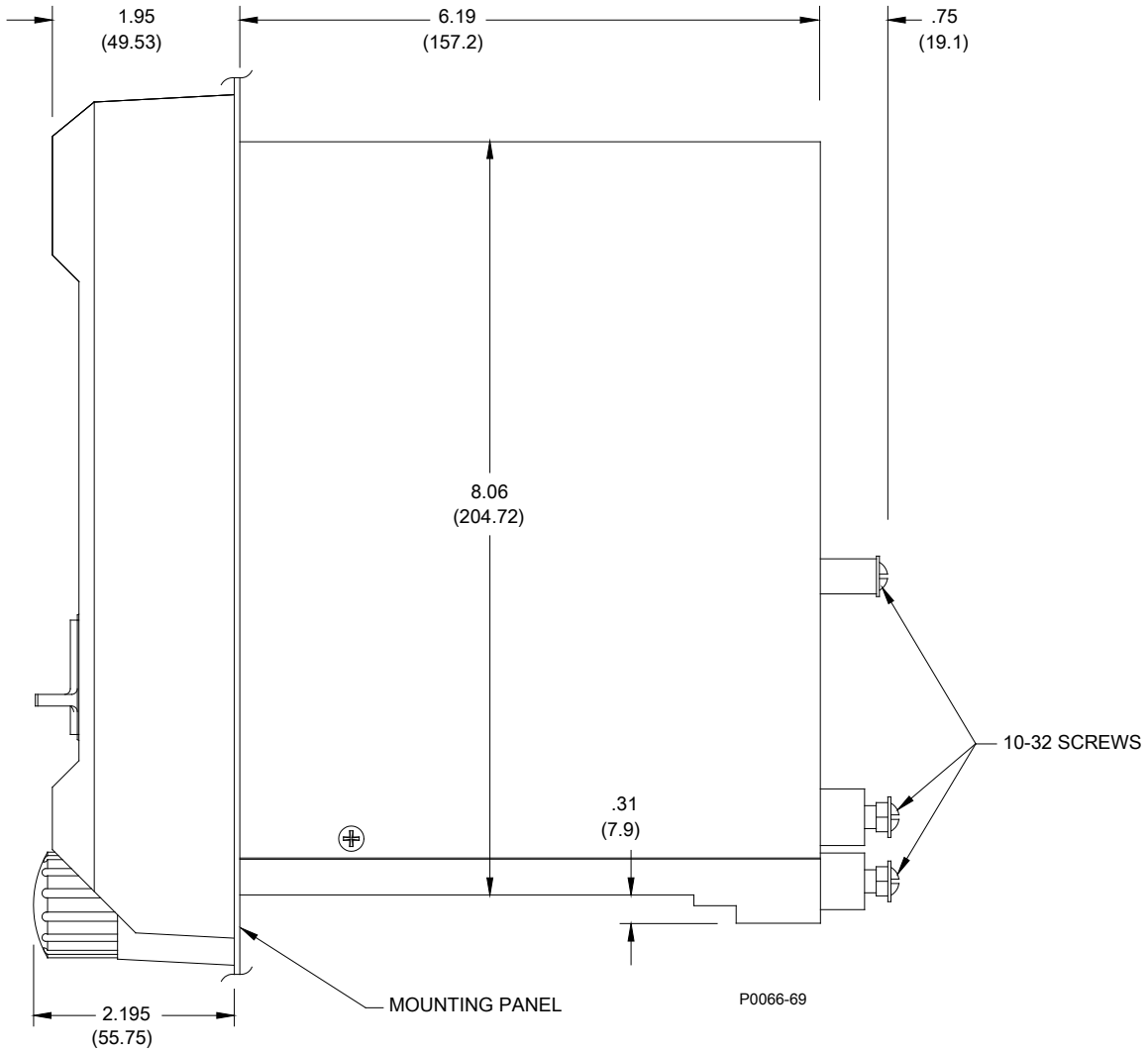

Figure 4-5. S1 Case Dimensions, Side View, Single-Ended, Semi-Flush Mount

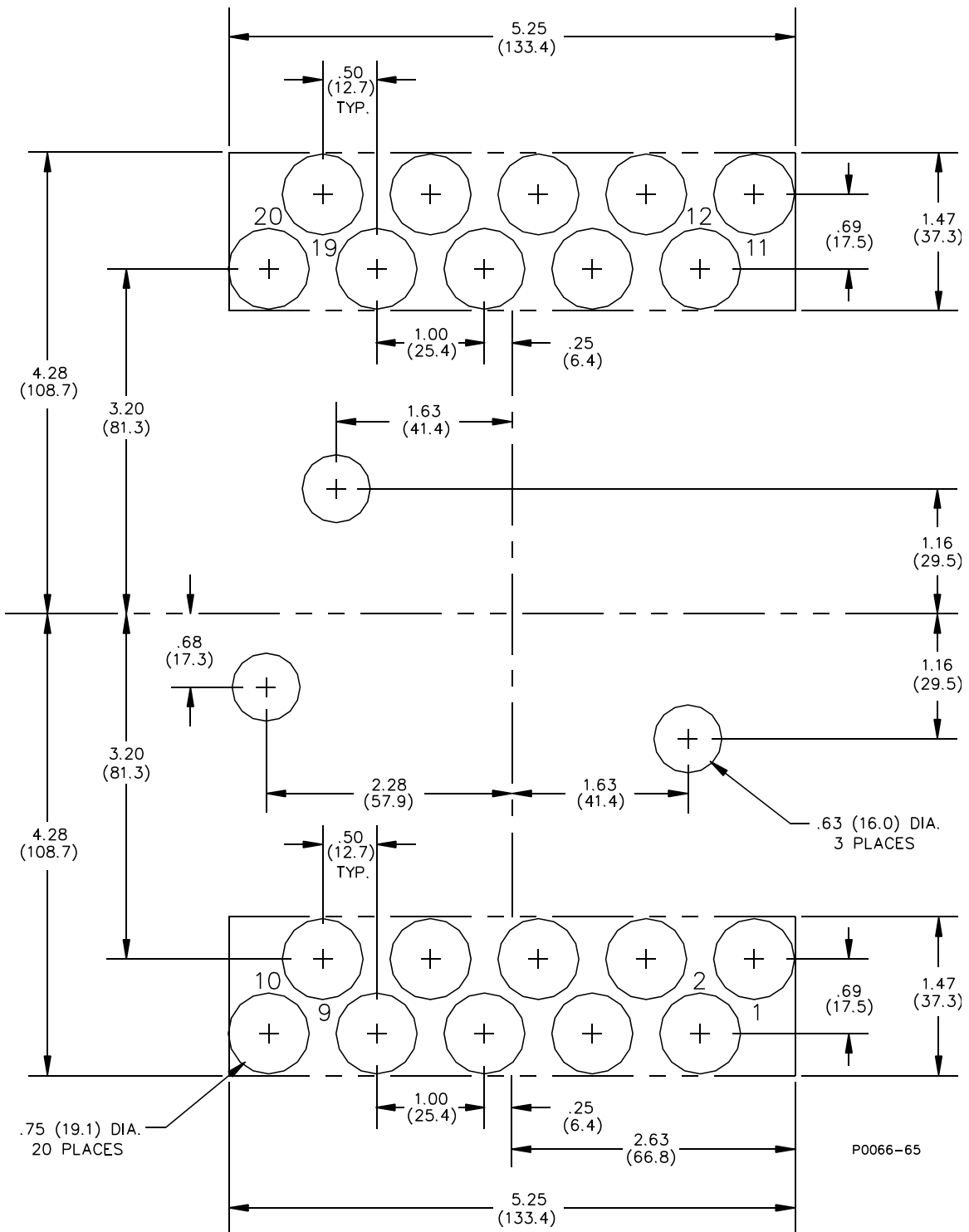

Figure 4-6. Panel Cutting/Drilling, Double-Ended, Projection Mount, S1 Case

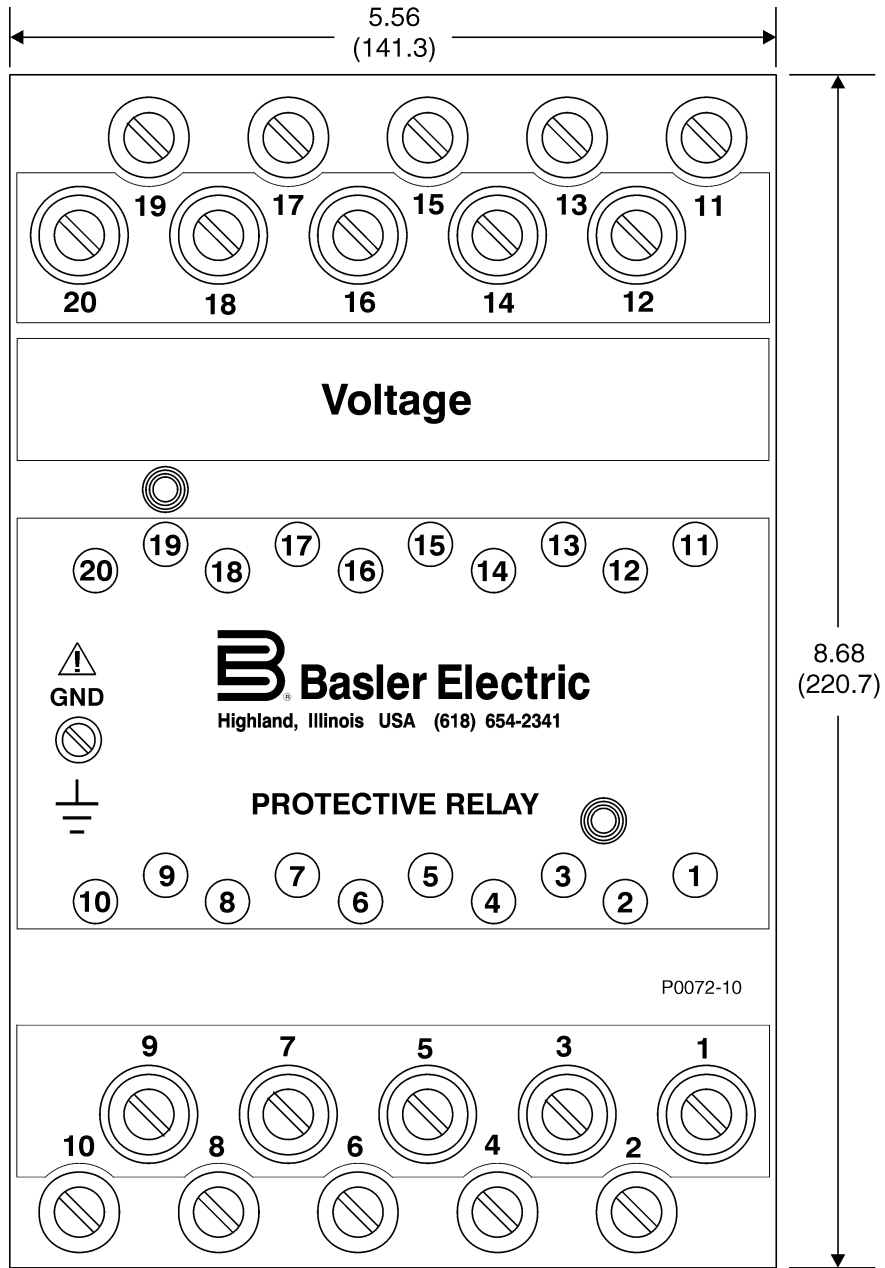

Figure 4-7. S1 Case Dimensions, Rear View, Double-Ended, Projection Mount

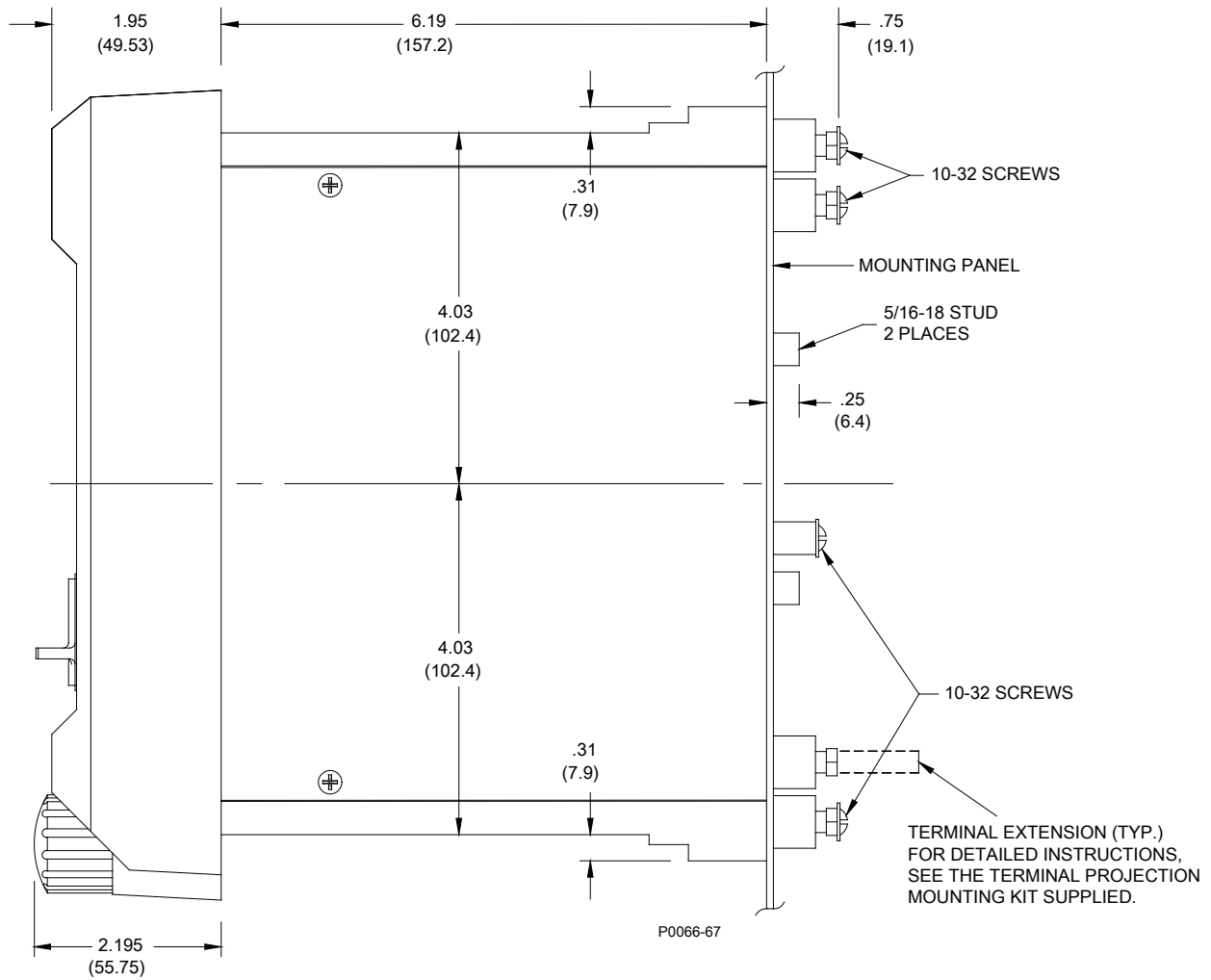

Figure 4-8. S1 Case Dimensions, Side View, Double-Ended, Projection Mount

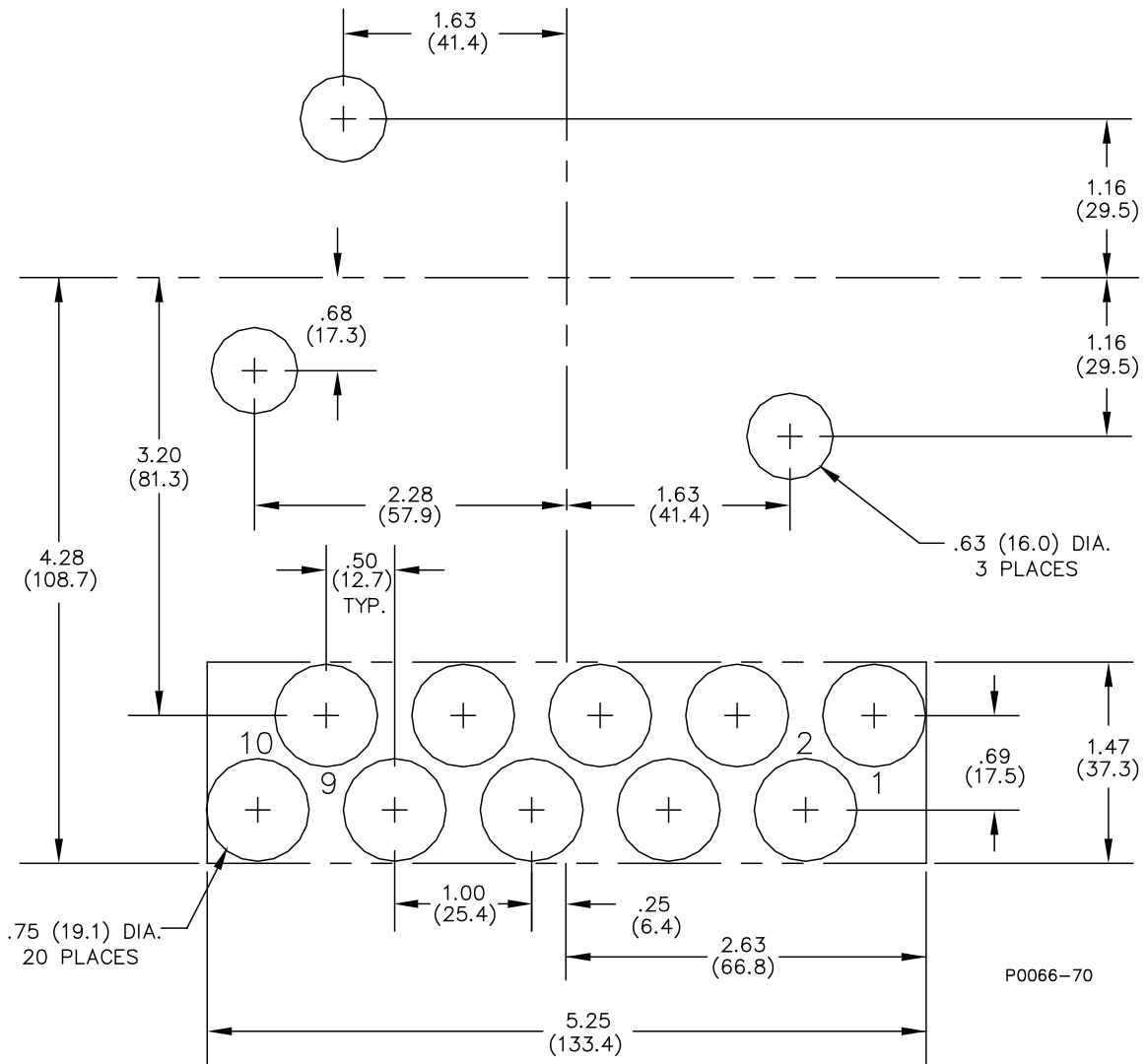

Figure 4-9. Panel Cutting/Drilling, Single-Ended, Projection Mount, S1 Case

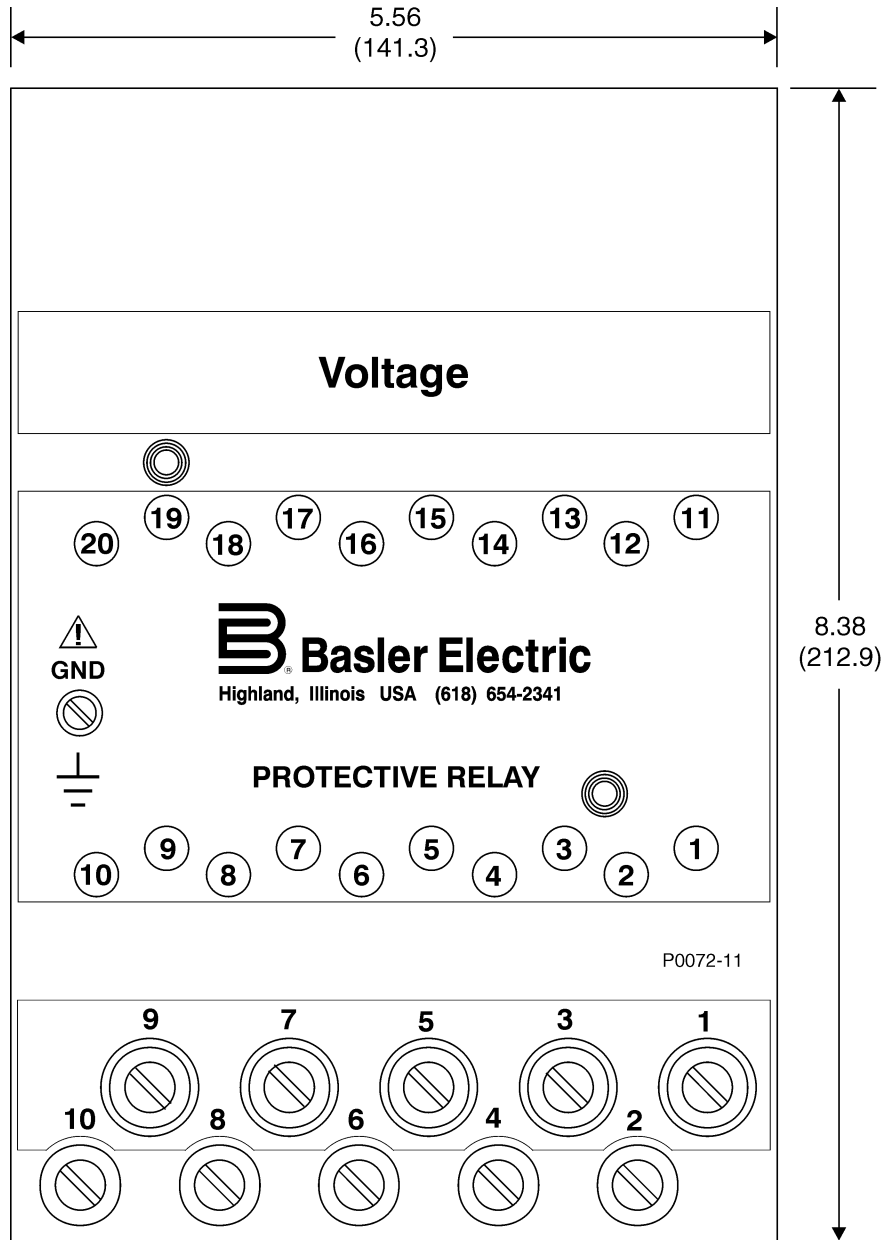

Figure 4-10. S1 Case Dimensions, Rear View, Single-Ended, Projection Mount

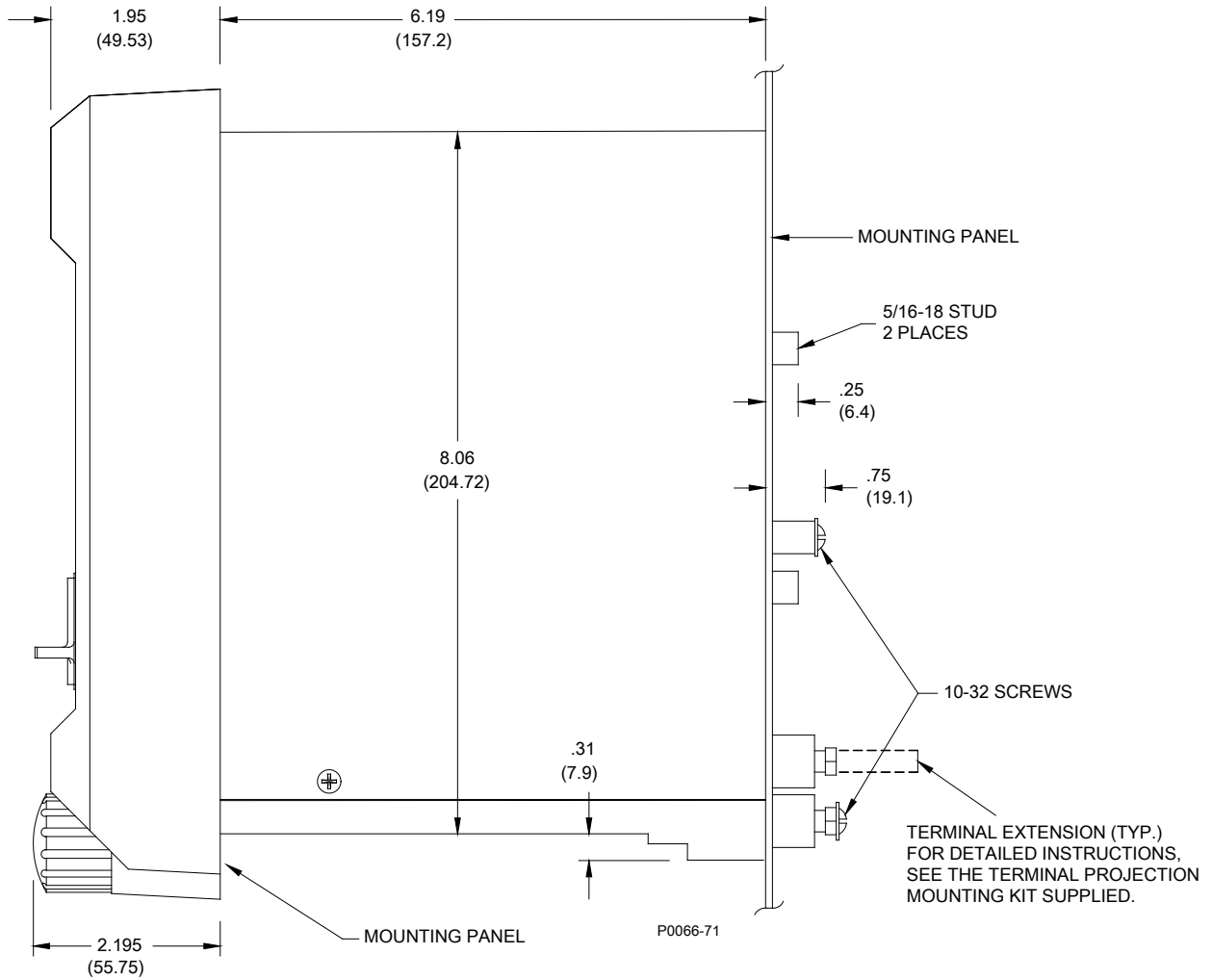

Figure 4-11. S1 Case Dimensions, Side View, Single-Ended, Projection Mount

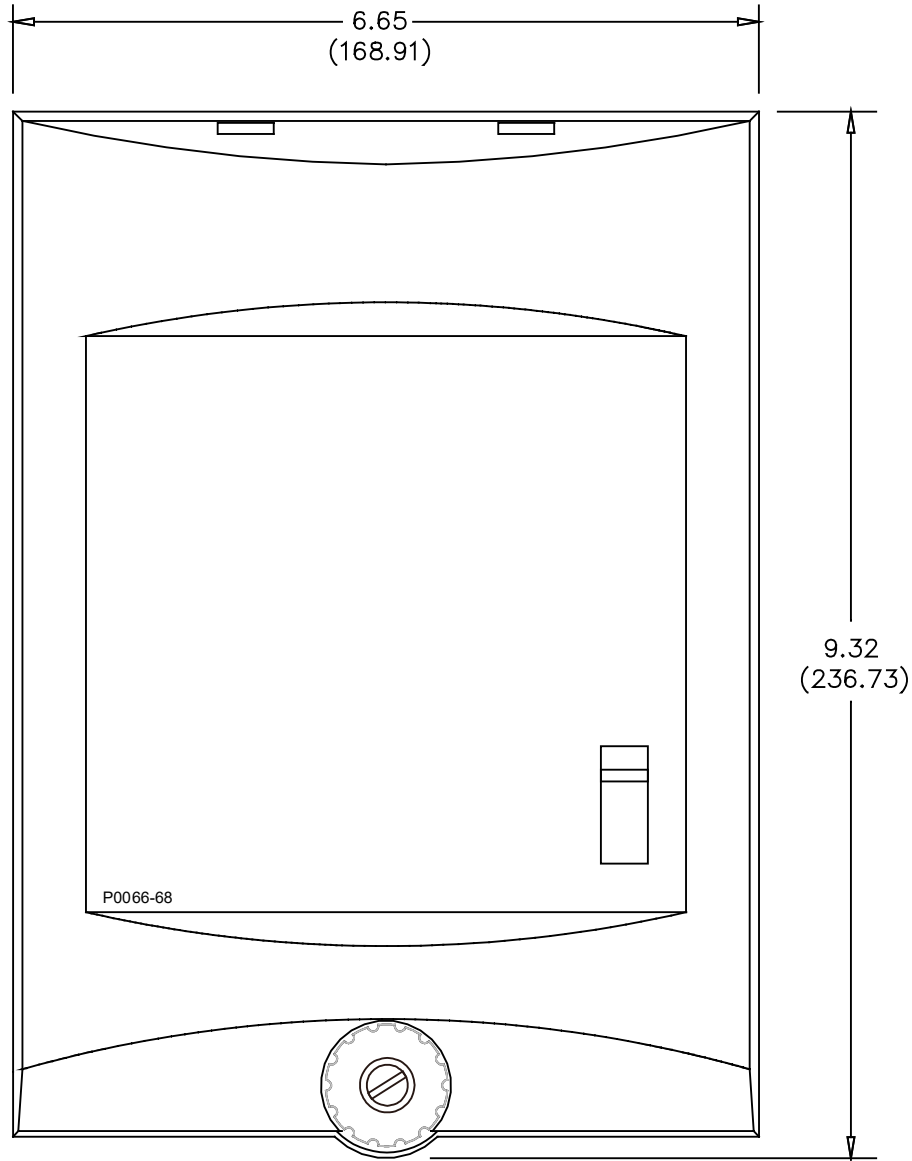

Figure 4-12. S1 Case Cover Dimensions, Front View

Connections

Be sure to check the model and style number of a relay before connecting and energizing the relay. Incorrect wiring may result in damage to the relay. Except where noted, connections should be made with wire no smaller than 14 AWG.

Typical internal connections are shown in Figures 4-13 through 4-15. Typical ac connections are shown in Figure 4-16. Typical dc connections are shown in Figure 4-17.

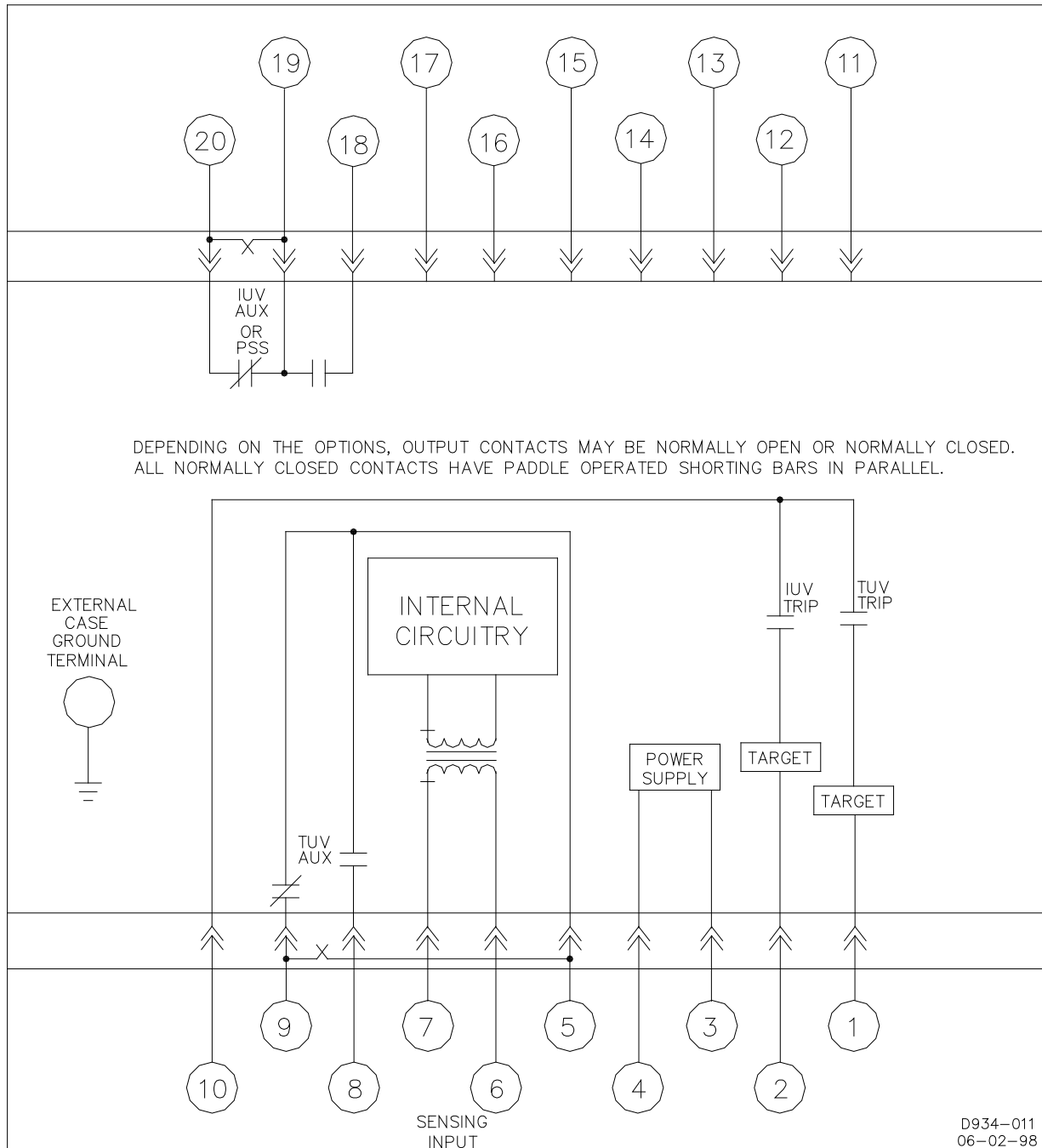

Figure 4-13. BE1-27 Internal Connections

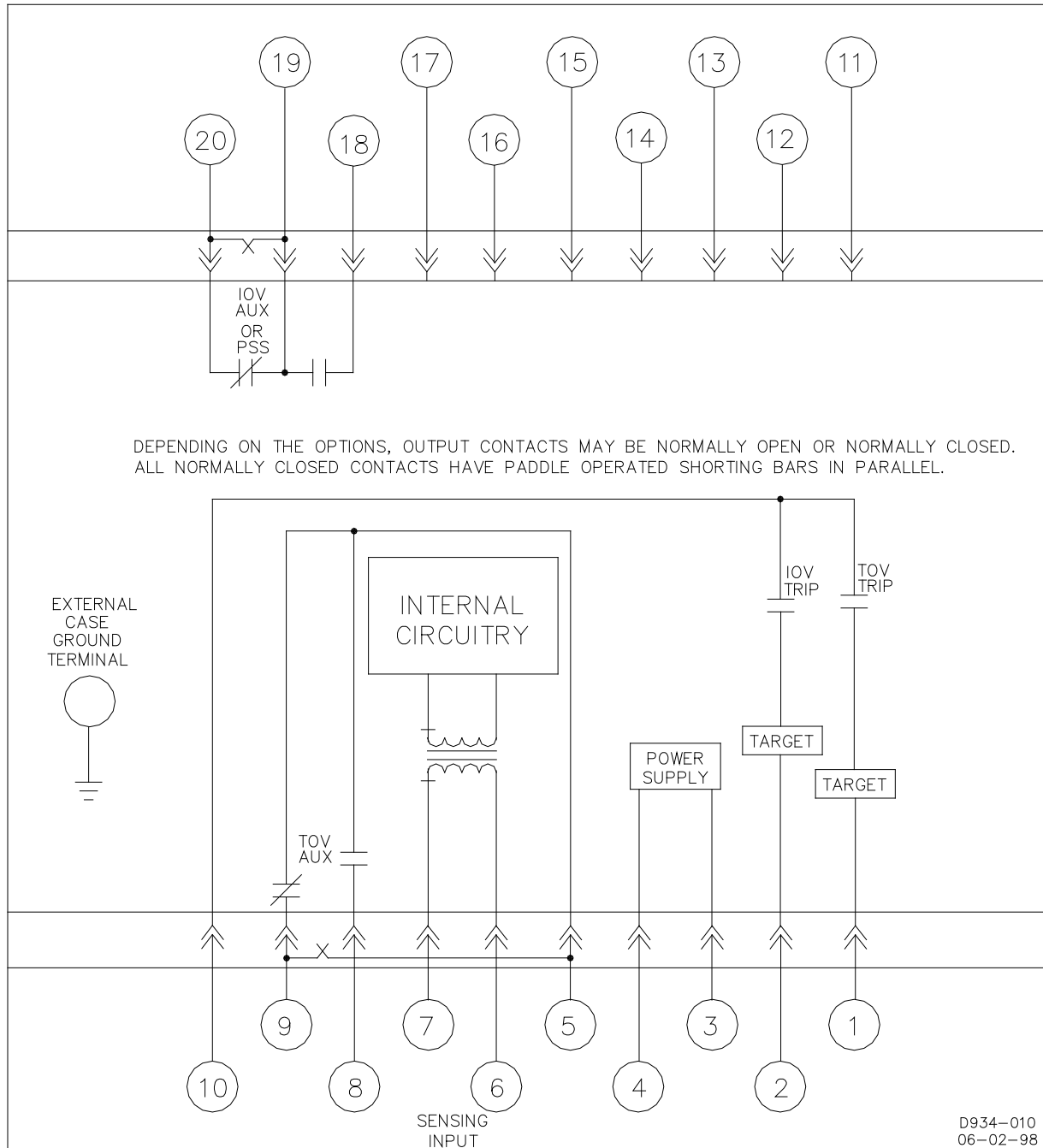

Figure 4-14. BE1-59 Internal Connections

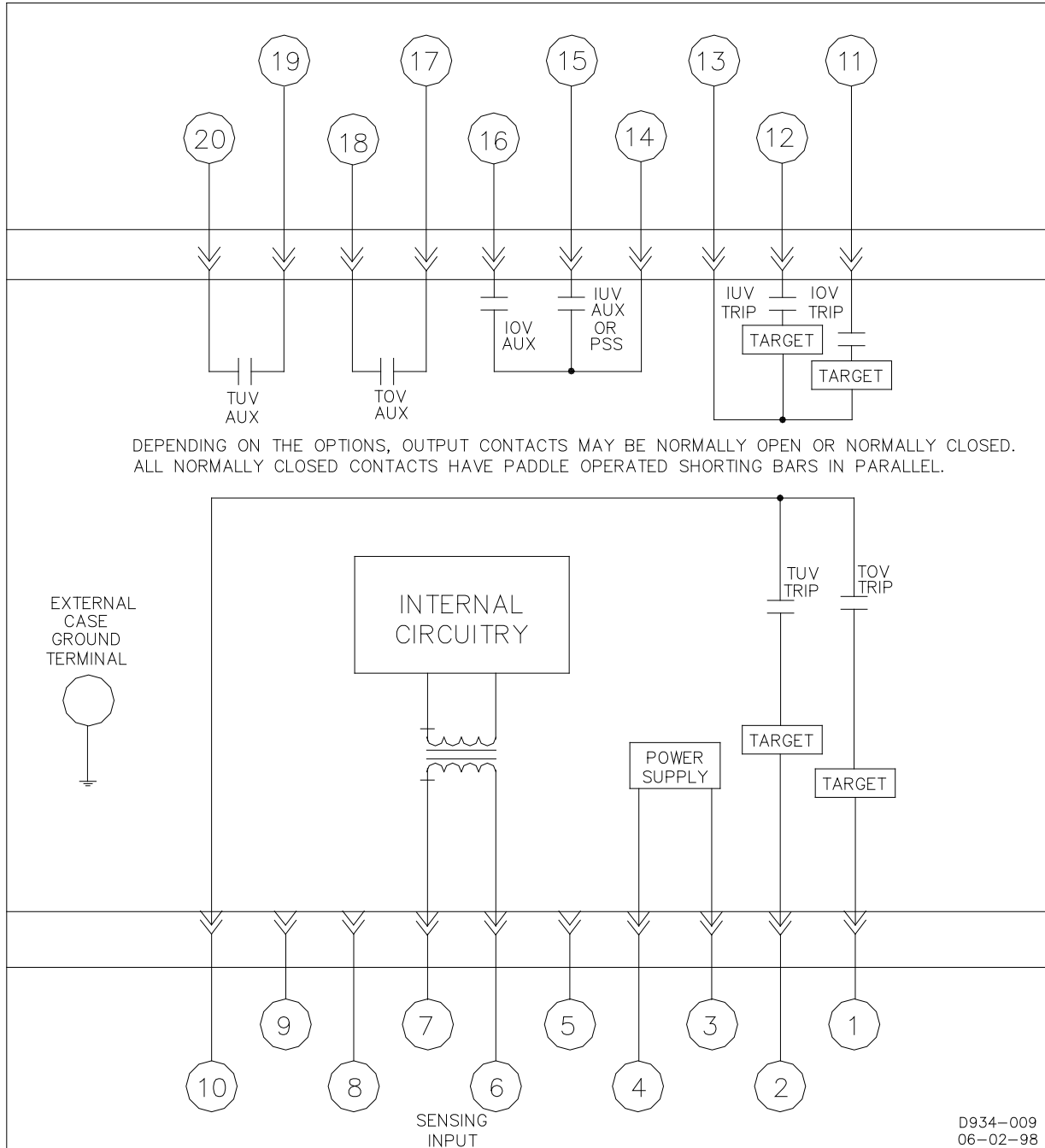

Figure 4-15. BE1-27/59 Internal Connections

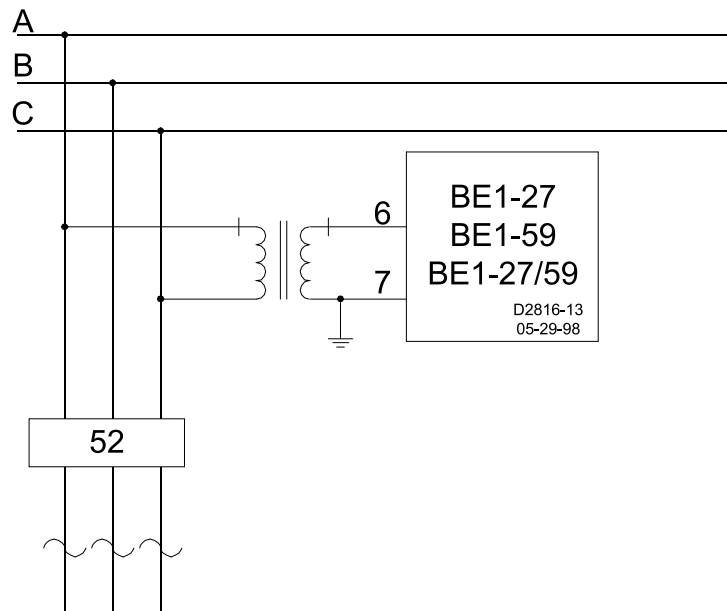

Figure 4-16. Typical AC Connections

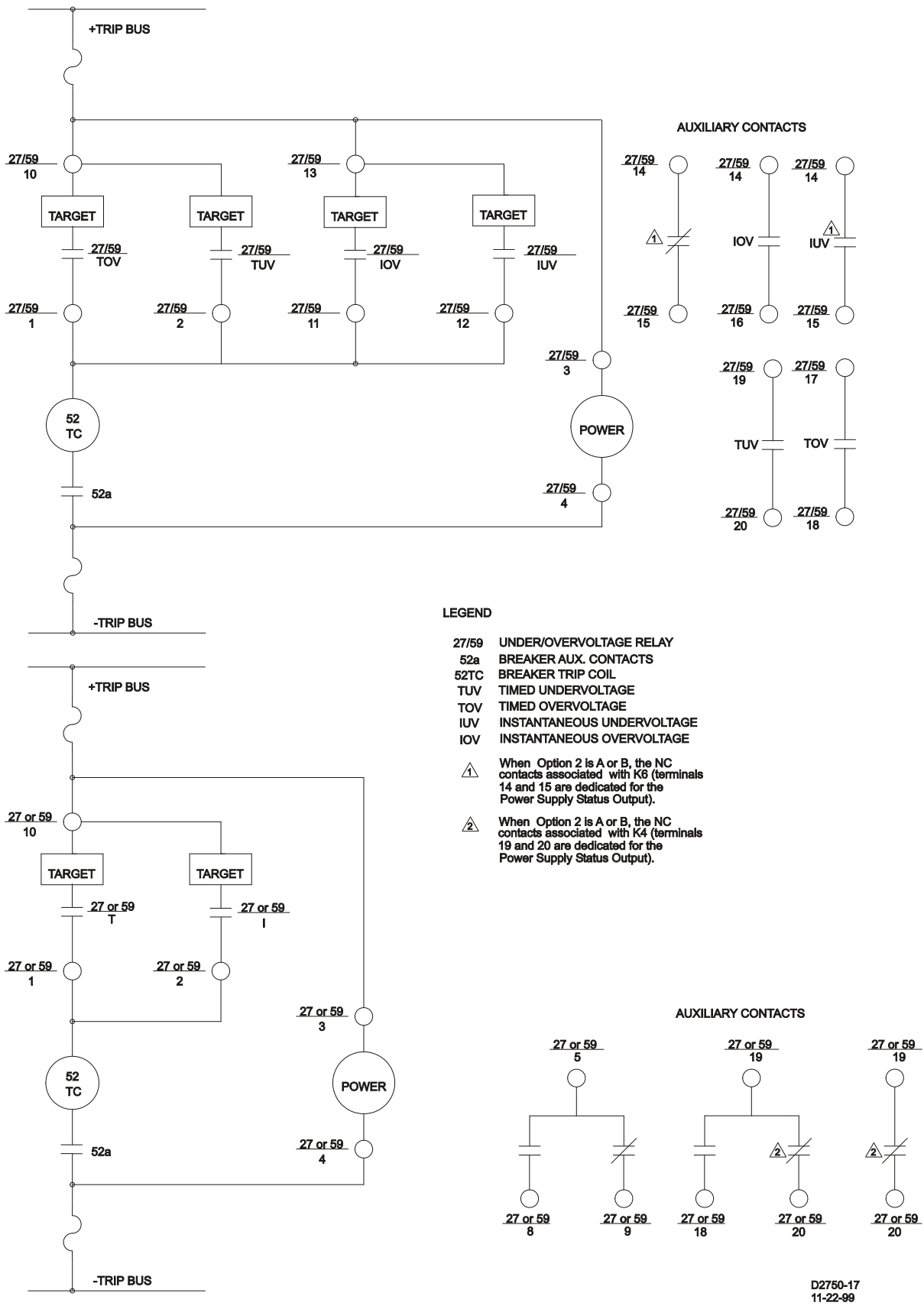

Figure 4-17. Typical DC Connections

Maintenance

BE1-27, BE1-59, and BE1-27/59 relays require no preventative maintenance other than a periodic operational check. If the relay fails to function properly, contact Technical Sales Support at Basler Electric to coordinate repairs.

Storage

This device contains long-life aluminum electrolytic capacitors. For devices that are not in service (spares in storage), the life of these capacitors can be maximized by energizing the device for 30 minutes once per year.



5 • Testing

Introduction

The following procedures verify proper relay operation and calibration.

Results obtained from these procedures may not fall within specified tolerances. When evaluating results, consider three prominent factors:

- Test equipment accuracy
- Testing method
- External test set components tolerance level

Required Test Equipment

Minimum test equipment required for relay testing and adjustment is listed below. Refer to Figures 5-1 and 5-2 for the test setups.

Note

Commercially available frequency relay test sets with frequency and time generating accuracies exceeding those of the relay and including electronic switching, may be used.

- Appropriate ac or dc power source for relay operation.
- Appropriate ac source for frequency sensing. (A source with frequency stability of 0.00002 Hz must exhibit phase noise of less than 90 dB for accurate measurement. The accuracy and stability of this source is necessary as the relay precisely measures the period between positive going zero-crossings of the applied waveform and responds instantaneously to the sensed condition.)
- Hardware (battery and lamp, multimeter, etc.) or method of determining that the output contacts close.

Operational Test

Power Supply Status Output (Option 2-A or B)

1. With the unit in a powered-up condition, verify that the power supply status output contacts are energized open.
2. Remove input power and verify that the status output contacts close.

Pickup

1. Connect the test circuits shown in Figure 5-1 as necessary for the functions included in your relay model. See Table 5-1. Turn all undervoltage pickup controls fully CCW and all overvoltage pickup functions fully CW. Set all time delay controls to 00. Adjust T1 to nominal voltage for your sensing input range as indicated below.

Table 5-1. Sensing Input Range

Sensing Input Range		
2	3	4
120 Vac	120 Vac	240 Vac

Note

Results assume normally open output contacts. Test indicator states will be opposite for normally closed output contacts.

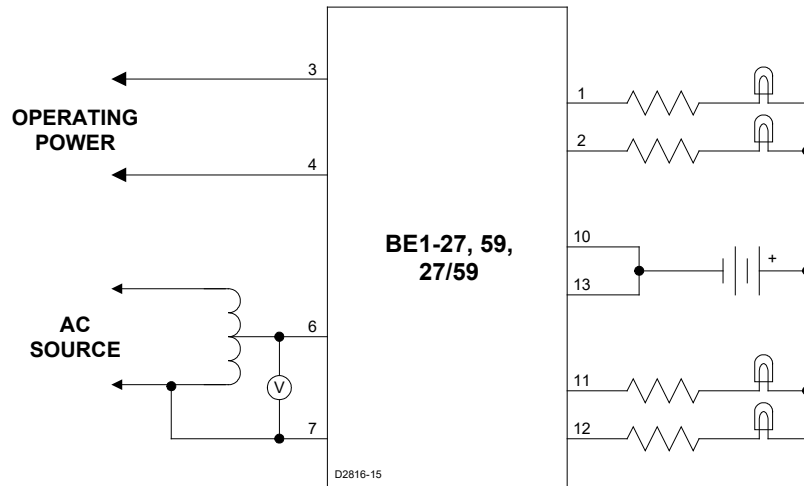

Figure 5-1. Pickup and Dropout Test Circuit Diagram

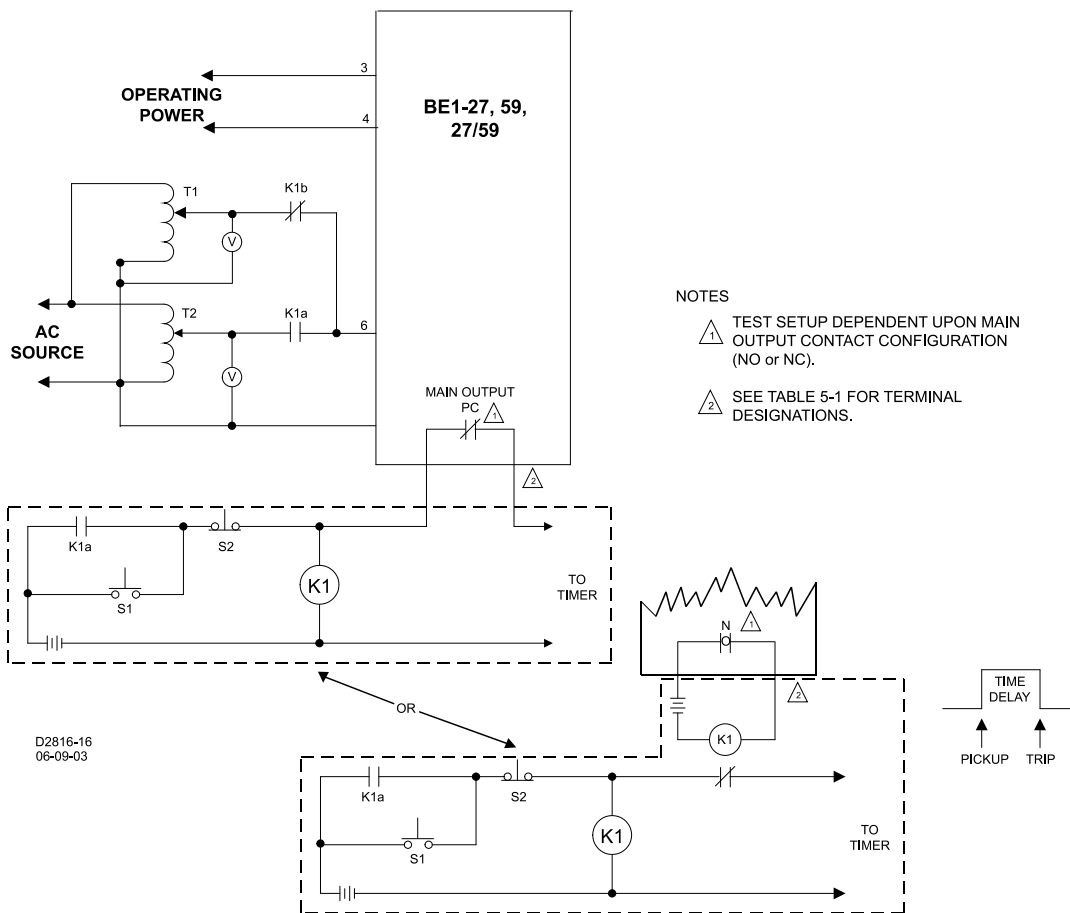

Figure 5-2. Timing Test Circuit Diagram

RESULT: In relays with Sensing Input Range 2, the OVER PICKUP indicator is illuminated as well as the timed and instantaneous overvoltage test indicators. In units with Sensing Input Range 3 or 4, all pickup and test indicators will be extinguished.

Table 5-2. Output Terminals

Pickup Function	Relay Model		
	27	59	27/59
Timed Undervoltage	1-10	—	2-10
Instantaneous Undervoltage	2-10	—	12-13
Timed Overvoltage	—	1-10	1-10
Instantaneous Overvoltage	—	2-10	11-13

Note

Steps 2 through 4 apply only to units with Sensing Input Range 2.

- Slowly decrease the T1 voltage until the OVER PICKUP indicator and the timed and instantaneous overvoltage test indicators extinguish. Slowly increase the T1 voltage until the OVERVOLTAGE PICKUP indicator and the timed and instantaneous overvoltage test indicators illuminate. Record the voltage.

RESULT: This voltage is between 39.2 and 40.8 Vac.

- Turn the timed and instantaneous OVERVOLTAGE PICKUP controls fully CCW. Slowly decrease the T1 voltage until the OVERVOLTAGE PICKUP indicator and the timed and instantaneous test indicators extinguish.
- Slowly increase the voltage at T1 until the OVERVOLTAGE PICKUP indicator and the timed and instantaneous overvoltage test indicators illuminate. Measure and record the voltage.

RESULT: This voltage is between 0.5 and 1.5 Vac.

This concludes the pickup test for units with Sensing Input Range 2.

Note

Steps 5 and 6 apply only to undervoltage functions.

- Slowly decrease the voltage at T1 until the UNDER PICKUP indicator and the timed and instantaneous test indicators illuminate. Measure and record the voltage.

RESULT: The voltage is between 53.9 and 56.1 Vac for Sensing Input Range 3 or between 107.8 and 112.2 Vac for Sensing Input Range 4.

- Increase T1 voltage to 170 Vac for Sensing Input Range 3 or 330 Vac for Sensing Input Range 4. Turn all undervoltage pickup controls fully CW. Slowly decrease T1 voltage until the UNDER PICKUP indicator and timed and instantaneous undervoltage test indicators illuminate. Measure and record the voltage.

RESULT: This voltage is between 156.8 and 163.2 Vac for Sensing Input Range 3 or between 313.6 and 326.4 for Sensing Input Range 4.

This concludes the pickup test for the undervoltage functions.

Note

Steps 7 and 8 apply only to overvoltage functions.
--

- Slowly increase the T1 voltage until the OVER PICKUP indicator and the timed and instantaneous overvoltage test indicators illuminate. Measure and record the voltage.

RESULT: This voltage is between 156.8 and 163.2 Vac for Sensing Input Range 3 or between 313.6 and 326.4 for Sensing Input Range 4.

Note

Step 8 applies only to BE1-59 relays with Sensing Input Range 3 or 4.

- Decrease the T1 voltage to 50 Vac. Turn all overvoltage pickup controls fully CCW. Slowly increase the T1 voltage until the OVER PICKUP indicator and the timed and instantaneous overvoltage test indicators illuminate. Measure and record the voltage.

RESULT: The voltage is between 53.9 and 56.1 Vac for Sensing Input Range 3 or between 107.8 and 112.2 Vac for Sensing Input Range 4.

This concludes the pickup test.

Timing

The following procedure verifies timing characteristics.

- Connect the test circuit shown in Figure 5-2. Output terminal connections are dependent on the function to be tested. See Table 5-1.
- Adjust the under or overvoltage pickup settings and the T1 and T2 tap voltage levels as indicated in Table 5-3 for the function being tested.

Table 5-3. T1 and T2 Tap Voltage Levels

Sensing Range	Over Pickup	Under Pickup	T1 Voltage	T2	
				Over	Under
2	30	—	20	40	—
3	120	100	110	150	70
4	240	200	220	300	140

- Set the time delay control for the function being tested to 00 (50 ms or less). Press and release S2 to ensure that K1 is de-energized. Reset the timer. Press and release S1.

RESULT: The timer displays a response time, dependent on timing type, as indicated in Column 1 of Table 5-4.

Table 5-4. Timing Test Results

Timing Type	Column 1		Column 2	
Instantaneous	50 ms or less		50 ms or less	
Definite	0.050 to 0.150 sec		9.702 to 10.098 sec	
	Under	Over	Under	Over
Short Inverse	0.000 to 0.343 sec	0.000 to 0.349 sec	6.418 to 7.458 sec	6.799 to 7.901 sec
Medium Inverse	0.157 to 0.557 sec	0.176 to 0.576 sec	25.336 to 29.445 sec	26.770 to 31.111 sec
Long Inverse	0.433 to 0.833 sec	0.464 to 0.864 sec	50.417 to 58.593 sec	53.336 to 61.985 sec

4. Set the time delay control for the function being tested to 01 (0.1 seconds). Press and release S2 to ensure that K1 is de-energized. Reset the timer. Press and release S1.

RESULT: The timer displays a response time, dependent on timing type, as indicated in Column 1 of Table 5-4.

5. Press and release S2. Set the time delay control for the function being tested to 99 (9.9 seconds). Reset the timer. Press and release S1.

RESULT: The timer displays a response time, dependent on timing type, as indicated in Column 2 of Table 5-4.

6. Repeat Steps 1 through 5, as necessary, for each function's time delay control.

This concludes the operational test procedure.

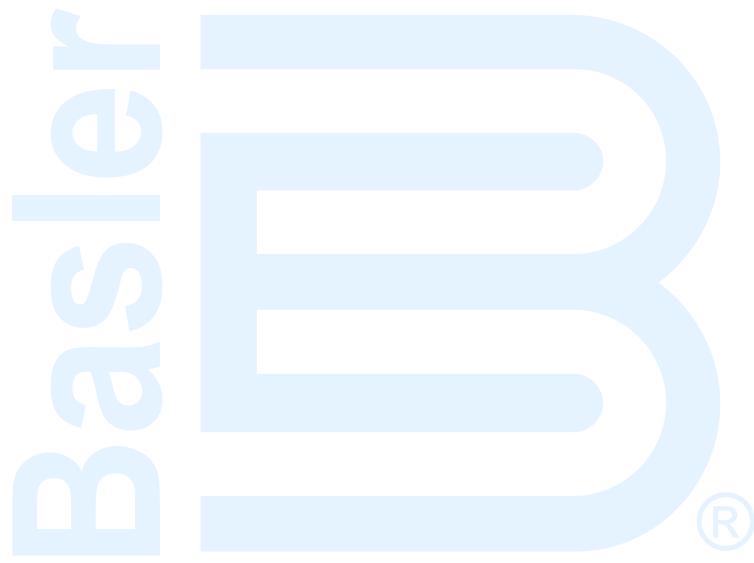



12570 Route 143
Highland IL 62249-1074 USA
Tel: +1 618.654.2341
Fax: +1 618.654.2351
email: info@basler.com

No. 59 Heshun Road Loufeng District (N)
Suzhou Industrial Park
215122 Suzhou
P.R. CHINA
Tel: +86 512.8227.2888
Fax: +86 512.8227.2887
email: chinainfo@basler.com

111 North Bridge Road
15-06 Peninsula Plaza
Singapore 179098
Tel: +65 68.44.6445
Fax: +65 68.44.8902
email: singaporeinfo@basler.com